



**LENNOX®**

**CLIMATIC USER MANUAL**

**RT**

**General programm  
version 3**

**Version anglais**



# CONTENTS

	Page
The CLIMATIC .....	2
Set points .....	5
Initialisation function .....	5
Configuration .....	6
ON-Off function .....	6
Standby function.....	6
Cancellation of standby functions.....	7
Anticipation of start-up at end of standby mode .....	7
« Night » function .....	7
Control.....	8
Autorisation of offloading.....	9
Humidity control.....	11
Ventilation.....	11
Compressor.....	12
Crankcase heaters .....	13
Outdoor air damper .....	13
Proportional cooling valve, chilled water coil .....	13
Proportional heating valve, hot water coil or Triac .....	13
Humidifier .....	14
Incident codes .....	14
Notions of Octets and Bits.....	21
Board link (J9).....	21
RS-232 (J11) link to a computer or B.M.S. ....	22
Table of J-BUS addresses .....	23
Variables .....	27
Display.....	30
Definition of incident codes for CAT units, ROOFTOP units and MODUL'AIR units.....	32

# THE CLIMATIC.

## Characteristics.

### Outputs.

Potential free all-or-nothing actuator

Contact limits:

AC: 10 A 250 V resistive load

4 A 250 V resistive load.

With an inductive load, an RC (resistive capacitive) circuit must be installed on the terminals.

Analogue output

Supplies a voltage of 0 to 10 Volt dc.

### Inputs. (Shielded wire is mandatory)

Resistive sensor:

C.T.N. measurement range: 200  $\Omega$  to 600 K $\Omega$

### Display.



The display has 5 keys :

**+** : By pressing this key, the values of the setpoints and variables displayed can be increased.

**-** : By pressing this key, the values of the setpoints and variables displayed can be decreased.

**H** : Enables readout and adjustment of hours, minutes and days.

Setting the time on the CLIMATIC control:



Press the H key once, The time is displayed.



Press the H key a second time H, the hours are displayed. Modify using + or -.



Press the H key a third time, the minutes are displayed. Modify using + or -.



press the H key a fourth time, the day of the week is displayed. Modify using + or -.

Note.: Sunday = 1, Monday = 2, ... , Saturday = 7

**C** : Enables access to and modification of the setpoints. These variables are displayed in the corresponding units. When the key is pressed, the setpoint number (00 to 15) appears, when the key is released, the value of the variable is displayed. Each press of the C key scrolls up the next setpoint. The value of the setpoint displayed can be modified with the + and - keys.

**V** : This key gives access to internal variables. When it is pressed, the number of the variable is displayed and when it is released, the value of that variable is displayed. To change addresses, use the + and - keys.

Remark :

A **manual** reset procedure requiring the user to press several keys simultaneously may be necessary to clear certain defaults.

To check the wiring to a board input, call up the address corresponding to the sensor or contact.

*Analysis of information :*

When the pointer points to an address between 0 and 15, one of the following cases applies :

- if the board input is shorted, the figure 99,5 will be displayed.
- if the board input is open ended, the figure -28 will be displayed.
- if a sensor or resistance is placed between the two terminals, a temperature will be displayed.

If a contact is wired without a sensor,

- if the contact is closed, the figure 1 is displayed if the unit is L (logic), or 255 if the unit is U (unit).
- if the contact is open, the figure 0 is displayed if the unit is L (logic), 000 if the unit is U (unit).

## **CLIMATIC RS 232 LINK**

CLIMATIC boards can be connected with a 4 wire link to a personal computer either directly, or using a phone modem, or to a programmable automated system in J-BUS mode via a bridge.

If such a connection is made, all the CLIMATIC variables can be monitored, or modified if necessary from a remote location.

## **CLIMATIC control variables**

### **Units**

CLIMATIC variables can be used under four types of units:

**[/C]** : this unit is used to express temperature values (amounts). The CLIMATIC control works with a temperature range from -28.0 to 99.5 in increments of 0,5.

This units can be recognised on the display by the presence of the decimal point.

**[/K]** : this unit is used to express temperature differences. The CLIMATIC works with a range from 000.0 to 127.5 in increments of 0,5.

This unit can be recognised by the presence of a decimal point and by display of 3 digits for the whole number part.

**[/U]** : this unit enables visualisation of amounts (percentages, times, counter values, The CLIMATIC works with a range from 000 to 255 in increments of 1.

These units can be recognised on the display by the absence of the decimal point.

**[/N]** : this unit is identical to /U units.

Variables using these units are not visible on the display.

**[/L]** : this unit enables visualisation of logic values 'OFF' 0 or 'ON' 1

This unit can be recognised by the presence of a figure 0 or a figure 1.

### **Organisation of variables**

The Z80 microprocessor manages 256 internal variables.

Distribution of the variables is as follows:

from variable nr 000 to variable nr 015	Temperature sensor inputs
from variable nr 016 to variable nr 031	Hygrometry sensor inputs or potential free contacts
from variable nr 032 to variable nr 120	Operating variables, not stored on shutdown
from variable nr 121 to variable nr 122	Analogue output values 000=0V / 255=10V
from variable nr 123 to variable nr 127	Hour counter on-off status
from variable nr 128 to variable nr 143	Logic outputs (relays)
from variable nr 144 to variable nr 175	Pre-assigned variables
from variable nr 176 to variable nr 178	1 <sup>st</sup> hour counter, stored on shutdown
from variable nr 179 to variable nr 181	2 <sup>nd</sup> hour counter, stored on shutdown
from variable nr 182 to variable nr 184	3 <sup>rd</sup> hour counter, stored on shutdown
from variable nr 185 to variable nr 187	4 <sup>th</sup> hour counter, stored on shutdown
from variable nr 188 to variable nr 190	5 <sup>th</sup> hour counter, stored on shutdown

from variable nr 192 to variable nr 207 Setpoints, stored on shutdown  
from variable nr 208 to variable nr 223 Inter-board variables, stored on shutdown  
from variable nr 224 to variable nr 255 Operating variables, stored on shutdown

All variables stored on shutdown are saved in battery (Li) maintained RAM (6116) in case 12V ac power supply is lost.

***A jumper located to the left of the battery  
must be placed in position T  
when the unit is put into service for the first time.***

A read-only memory or EPROM contains the variable management program on the board. Depending on the type of program and the type of unit, use of the variables may be different.

## SETPOINTS.

Spt. nr 0	<b>CONSA</b>	C	Desired conditioned space temperature	C <sub>1</sub>
Spt. nr 1	<b>MORTE</b>	K	Dead band between heating and cooling	C <sub>2</sub>
Spt. nr 2	<b>ABAIS</b>	K	Value of decrease of the CONSA setpoint in Standby or Night mode	
Spt. nr 3	<b>TROS_DU</b>	C	Requested dew point temperature for dehumidification	
Spt. nr 4	<b>TROS_HU</b> or <b>T_VOLET</b>	C	Requested dew point temperature for humidification	
Spt. nr 5	<b>T_CHAUD</b>	C	Outdoor t°. threshold for free-cooling lock-out	
Spt. nr 6	<b>T_FROID</b>	C	Outdoor t°. threshold for compressor operation lock-out	
Spt. nr 7	<b>MINIAIR</b>	U	Minimum % of outdoor air intake	C <sub>3</sub>
Spt. nr 8	<b>DV_J</b>	U	Daily setback time	C <sub>4</sub>
Spt. nr 9	<b>FV_J</b>	U	Time of return to Normal Operation after Daily Setback	C <sub>5</sub>
Spt. nr 10	<b>DV_H</b>	U	Time and Day of Weekly Setback	
Spt. nr 11	<b>FV_H</b>	U	Time and day of return to Normal after Weekly setback	
Spt. nr 12	<b>P_ANTI</b>	U	End of setback anticipation ramp	
Spt. nr 13	<b>FRIMAIR</b>	U	Regulation parameters	
Spt. nr 14	<b>MA_AR_D</b>	U	On/Off	
Spt. nr 15	<b>INIT</b>	U	Initialisation function	
246	<b>MODE_RT</b>	U	Configuration setpoint	
247	<b>M_VOLET</b>	C	Maximum outdoor t°. threshold for free-cooling lock-out	
248	<b>T_FR_34</b>	C	Outdoor air T° threshold setpoint for lockout of mechanical cooling with compressors 3 & 4	
249	<b>DING_A</b>	U	Integration duration setpoint	
250	<b>ENCL_F</b>	K	Setpoint Cooling regulation initiation threshold	
251	<b>DIFET_F</b>	K	Setpoint Cooling regulation differential threshold	
252	<b>ENCL_C</b>	K	Setpoint Heating regulation initiation threshold	
253	<b>DIFET_C</b>	K	Setpoint Heating regulation differential threshold	

*Rapid setpoint call-up on the full message display*

*To adjust supplementary setpoints (248 to 253) :  
Adjust setpoint n°015 to the number of the supplementary setpoint concerned,  
then adjust setpoint n°013 to the required value.*

*Caution :  
For setpoints in K units, multiply the setpoint value in nr 013 by 2 :  
( e.g. 1K = 002U )  
For setpoints in C units, add 28 to the setpoint value in nr 013 then multiply by 2  
( e.g. 22C → ( 22 + 28 ) × 2 = 100U )*

## INITIALISATION FUNCTION.

Zeroing of internal CLIMATIC counters is carried out as follows.

Set the INIT setpoint (setpoint nr 015) to the required value, change the setpoint, then press simultaneously on the + & - keys.

INIT = 240 Resets setpoints to factory values INIT = 245 Power up counter = 0 INIT = 250 Fan running hours = 0	INIT = 251 Compressor nr 1 operating hours = 0 INIT = 252 Compressor nr 2 operating hours = 0 INIT = 253 Compressor nr 3 operating hours = 0 INIT = 254 Compressor nr 4 operating hours = 0
---	--

## CONFIGURATION.

The MODE\_RT setpoint enables certain functions to be obtained

- bit n°0 : 001 : Fan stoppage in dead band
- bit n°1 : 002 : Fan stoppage in dead band after heating
- bit n°2 : 004 : No backup resistance heating during defrost
- bit n°3 : 008 : HEAT PUMP then 3-way valve
- bit n°4 : 016 : Cancellation of the HEAT PUMP function
- bit n°5 : 032 : Operation, Gas then HEAT PUMP
- bit n°6 : 064 : Fan re-start, then Free-cooling in Standby mode
- bit n°7 : 128 : Low capacity operation during the Standby mode

*The selection of several functions at the same time is made by adding values together.*

## ON-OFF FUNCTION.

Variables used :

MA_AR _D	setpoint nr 14, variable nr 206	On/Off
MA_AR	variable nr 096	Unit On/Off status

The system is declared «On» if setpoint nr 14 is at 001.

On units fitted with a display with complete readout,  
If the 'Local / Remote' button [S5] is 'ON' then,  
The « On » button [S3] at 'ON' will force setpoint nr 14 to a value of 001.  
The « Off » button [S3] at 'OFF' will force setpoint nr 14 to a value of 001.

## STANDBY FUNCTION.

Variables used :

D_VJ	setpoint nr 08, variable nr 200	adjustment of the start of daily unoccupied period
F_VJ	setpoint nr 09, variable nr 201	adjustment of the end of daily unoccupied period
D_VH	setpoint nr 10, variable nr 202	adjustment of the start of weekly unoccupied period
F_VH	setpoint nr 11, variable nr 203	adjustment of the end of weekly unoccupied period
P_ANTI	setpoint nr 12, variable nr 204	adjustment of the gradient for the anticipation function
ORDI	variable nr 221	information supplied by a B.M.S. Bit nr 0 : forced standby Bit nr 1 : forced standby cancellation
C_VEIL	input 2.0 24EL, variable nr 048	Standby forcing switch
C_RELAN	input 2.1 24EL, variable nr 049	Operation forcing switch
C_NUIT	input 2.5 24EL, variable nr 053	éNightl function switch
VEILLE	variable nr 098	Standby function
ANTICIP	variable nr 099	Anticipation function
HORSGEL	variable nr 100	Building frost protection function

A weekly and a daily standby function can be programmed via the CLIMATIC control.  
The VEILLE variable is ON when the function is activated.

During the standby function, the unit is stopped.

If the unit is fitted with an outdoor air damper, the 2nd level low discharge air safety function restarts unit ventilation (*see discharge air temperature safety*).

As a supplement to the Standby function a building frost protection function, HORSGEL, restarts the unit if indoor temperature drops below +12°C. This function is cancelled once indoor temperature rises back above 16°C.

In addition, anticipated unit restart can be programmed by the CLIMATIC control.

### CLIMATIC clock function

If DV\_J, setpoint n°08, has a value of 022 and FV\_J, setpoint n°09, has a value of 006 then the daily unoccupied period will be activated every day at 22.00 hours until 6.00 hours the next morning.



If DV\_H, setpoint n°10, has a value of 207 and FV\_H, setpoint n°11, has a value of 082, the weekly unoccupied period will be activated on the 7th day (Saturday) at 20.00 hours [20 7] until the 2nd day (Monday) at 8.00 hours [08 2].

The weekly function takes precedence over the daily function

### Full message display

If the 'Local / Remote' button [S5] is 'ON' then button [S1] at 'ON' will force the unit into Standby (unoccupied) mode

### External contact

Closing input 2.0 on the 24EL board forces the unit into Standby mode.

### RS-232 / J-BUS

Activation of bit nr 0 in the ORDI variable forces the unit into Standby mode.

## CANCELLATION OF STANDBY FUNCTIONS.

### CLIMATIC clock

To cancel the daily program, set the DV\_J, setpoint nr 08, & FV\_J, setpoint nr 09, to the same value.  
To cancel the weekly program, set the DV\_H, setpoint nr 10, & FV\_H, setpoint nr 11, to the same value

### Full message display

If the 'Local / Remote' button [S5] is at 'ON' then Setting button [S2] at 'ON' will cancel any request for Standby mode.

### External contact

Closing input 2.1 on the 24EL board cancels any requests for Standby mode.

### RS-232 / J-BUS

Activation of bit nr 1 in the ORDI cancels any request for Standby mode.

## ANTICIPATED START-UP AT THE END OF STANDBY MODE.

If the Roof-top unit is in standby mode through the action of the CLIMATIC clock, the unit can be restarted before the time set in setpoint, depending on the outdoor air temperature.

The number of hours of anticipation is calculated with the following formula:

$$Nb.d.heure = \frac{(+10^{\circ}C - T_{EXT}) \times P_{ANTI}}{16}$$

For example, if the outdoor air temperature is +0°C, with the loading ramp set at 006 and the end of standby set for 8h00, under these conditions, the number of hours of anticipation = 3, and the Roof-top unit will start at 5h00 instead of 8h00.

## « NIGHT » FUNCTION.

If input 2.5 on the 24EL board is closed, or if the Standby function is activated as well as bit nr 7 of the MODE\_RT variable, fan operation is maintained. The temperature setpoint is reduced by a value of ABAIS (setpoint nr 02).

## CONTROL.

Variables used :

CONSA	setpoint nr 00, variable nr 192	Desired conditioned space temperature
MORTE	setpoint nr 01, variable nr 193	Dead band between heating and cooling
ABAIS	setpoint nr 02, variable nr 194	Value of decrease of CONSA setpoint in Standby or Night mode
T_VOLET	setpoint nr 04, variable nr 196	Minimum outdoor t°. threshold for free-cooling lock-out
T_CHAUD	setpoint nr 05, variable nr 197	Outdoor t°. threshold for electric heater lock-out
T_FROID	setpoint nr 06, variable nr 198	Outdoor t°. threshold for compressor operation lock-out
M_VOLET	setpoint ----, variable nr 247	Maximum outdoor t° threshold for free-cooling lock-out
T_FR_34	setpoint ----, variable nr 248	OAT temp. threshold stp. for lockout compressors 3 & 4
DING_A	setpoint ----, variable nr 249	Integration time
ENCL_F	setpoint ----, variable nr 250	Setpoint Cooling regulation initiation threshold
DIFET_F	setpoint ----, variable nr 251	Setpoint Cooling regulation differential threshold
ENCL_C	setpoint ----, variable nr 252	Setpoint Heating regulation initiation threshold
DIFET_C	setpoint ----, variable nr 253	Setpoint Heating regulation differential threshold
T_AMB	input X0, variable nr 000	Conditioned space temperature
T_EXT	input X2, variable nr 002	Outdoor air temperature
T_SOUF	input X4, variable nr 004	Discharge temperature
MA_50	input 1.4 24EL, variable nr 044	50% compressor offloading switch
MA_100	input 1.5 24EL, variable nr 045	100% compressor offloading switch
MA_RE	input 1.6 24EL, variable nr 046	100% electric heat offloading switch
MA_BEC	input 1.7 24EL, variable nr 047	Hot water valve offloading switch
C_RNEUF	input 2.2 24EL, variable nr 050	100% outdoor air forcing switch
C_RRECY	input 2.3 24EL, variable nr 051	100% recycled air forcing switch
C_RMINI	input 2.4 24EL, variable nr 052	Minimum outdoor air forcing switch
CONSA_A	variable nr 066	Real value of conditioned space temperature setpoint
CONSA_S	variable nr 067	Real value of discharge air temperature setpoint
MAXI_F	variable nr 069	Maximum number of cooling control stages.
MAXI_C	variable nr 070	Maximum number of heating control stages.
PROF	variable nr 075	Cooling control power factor
PROC	variable nr 076	Heating control power factor
STEP_GF	variable nr 077	Number of compressor stages for cooling operation
STEP_GC	variable nr 078	Number of compressor stages for heating operation
STEP_RC	variable nr 080	Number of electric heat stages
REGUL_F	variable nr 109	Opening of the proportional valve for cooling
REGUL_C	variable nr 110	Opening of the proportional valve for heating

Two power factors, PROF for cooling, and PROC for heating, are calculated based on the difference in temperature between the setpoint and the temperature read by the CLIMATIC control.

For cooling, the reference point is defined as CONSA.

For heating, the reference point is defined as CONSA - MORTE.

Progression of the cooling power factor is limited by the ENCL\_F and DIFET\_F setpoints.

Progression of the heating power factor is limited by the ENCL\_C and DIFET\_C setpoints.

If ENCL\_F or ENCL\_C has a value of 0, the power factor concerned is no longer limited.

Power factors are periodically recalculated by the CLIMATIC control. Integration time, DING\_A is adjustable. This parameter should depend on the unit air throughput rate and temperature variations within the conditioned space.

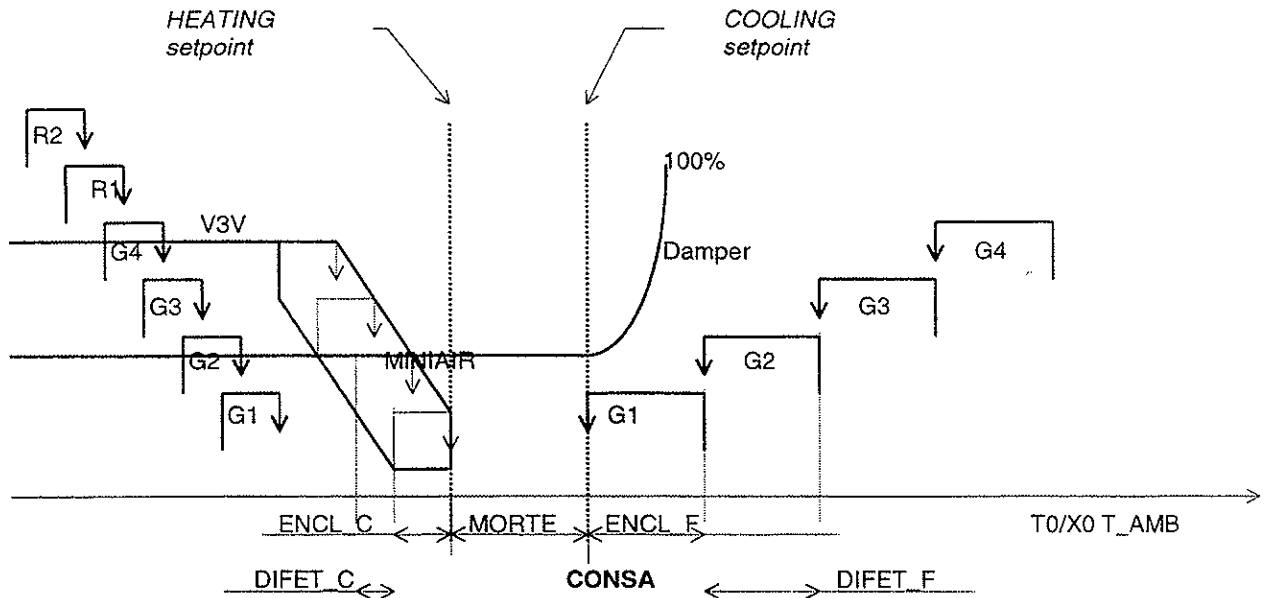

### Offsetting the conditioned space temperature setpoint

The required temperature for the conditioned space is adjustable with the CONSA setpoint (setpoint nr 00). If the unit is connected to a remote control box, the temperature required in the conditioned space can be adjusted with the potentiometer, between +15°C and +25°C. This option should be wired to input X14 on the CLIMATIC control. If the Standby or Night functions are activated, the setpoint is reduced by the value of the ABAIS setpoint (setpoint nr 02).

### Discharge air temperature setpoint calculation (option)

In the case of discharge air temperature control, calculation of the setpoint follows same rules shown above.

## OFFLOADING AUTHORISATION.

### Economiser

#### Outdoor air temperature :

The Economiser function is authorised if :  
 $T_{EXT} < T_{AMB}$  and if  $T_{EXT} > Spt. T_{VOLET}$  and if  $T_{EXT} < Spt. M_{VOLET}$

#### Enthalpy function.

A calculation of the weight of water in a given volume of air can be made by the CLIMATIC control, if the humidity sensor corresponding to this function is wired to terminals X3. If such is the case, and under certain outdoor air conditions, the economiser function will be locked out and the outdoor air intake damper will be positioned at the minimum outdoor air intake position.

#### Full message display

If the 'Local / Distance' button [S5] is at 'ON' then  
 If button [D4] is 'ON' the damper is forced into the « 100% return air recycling » position.  
 If button [D5] is 'ON' the economiser function is cancelled.  
 If button [D6] is 'ON' the damper will be forced into the « 100%. Outdoor air » position.

#### External contact

Closing input 2.3 on the 24EL board forces the damper into the 100% recycled return air position.  
 Closing input 2.4 on the 24EL board cancels the Economiser function.  
 Closing input 2.2 de la carte 24EL board forces the damper into the 100% Outdoor Air position.

## **RS-232 / J-bus**

Activation of bit nr 6 in the ORDI variable cancels the Economiser function.

## **Compressors**

### **Outdoor air temperature**

Compressor cooling is authorised if :  
T\_EXT > setpoint. T\_FROID

Mechanical cooling with compressors 3 & 4 is authorised if  
T\_EXT > Spt. T\_FR\_34

### **Full message display**

If the 'Local / Distance' button [S5] is at 'ON' then  
If button [D2] is at 'ON' compressor operation is forced to 50%.  
If button [D3] is at 'ON' forces offloading of 100% of compressor operation.

### **External contact**

Closing input 1.4 on the 24EL board forces 50% compressor offloading.  
Closing input 1.5 on the 24EL board forces 100% compressor offloading.

## **RS-232 / J-bus**

Activation of bit nr 3 of the ORDI variable forces 50% compressor offloading.  
Activation of bit nr 4 of the ORDI variable forces 100% compressor offloading.

## **Electric resistance heaters / Gas burners**

### **Outdoor air temperature**

Electric resistance heater operation is authorised if :  
T\_EXT < Setpoint. T\_CHAUD or during the defrost phase

### **Full message display**

If the 'Local / Distance' button [S5] is at 'ON' then  
If button [D1] is at 'ON' the electric resistance heaters are offloaded 100%.

### **External contact**

Closing input 1.6 on the 24EL board forces 100% offloading of the electric heaters.

## **RS-232 / J-bus**

Activation of bit nr 2 of the ORDI variable forces 100% offloading of the electric heaters.

## **Hot water heating coil**

### **External contact**

Closing input 1.7 on the 24EL board forces 100% offloading of the heating coil.

## **RS-232 / J-bus**

Activation of bit nr 5 of the ORDI variable forces 100% offloading of the heating coil.

## HUMIDITY CONTROL.

Variables used :

TROS_DU	setpoint nr 03, variable nr 195	Dew point temperature required for dehumidification
TROS_HU	setpoint nr 04, variable nr 196	Dew point temperature required for humidification
H_AMB	input X1, variable nr 017	Relative humidity of conditioned space air
H_EXT	input X3, variable nr 019	Relative humidity of outdoor air
ENTHA	variable nr 083	Enthalpy control function
STEP_DU	variable nr 085	Dehumidification function
STEP_HU	variable nr 086	Humidification function

### Enthalpy function

A calculation of the weight of water in a given volume of air can be made by the CLIMATIC control, if the humidity sensor corresponding to this function is wired to terminals X3. If such is the case, and under certain outdoor air conditions, the economiser function will be locked out and the outdoor air intake damper will be positioned at the minimum outdoor air intake position.

### Dehumidification and Humidification functions

On RTD type dehumidifying Rooftop units, indoor humidity control is provided. In this case, relative humidity is calculated according to conditioned space temperature and a dew point temperature threshold provided by the TROS\_DU setpoint. If the relative humidity detected in the conditioned space by the CLIMATIC control is greater than the calculated threshold, the dehumidification function is activated.

In the same manner, the TROS\_HU setpoint is applied for management of a humidifier.

## VENTILATION.

Variables used :

C_PV	Input 2.6 24EL, variable nr 054	Low speed switch
ORDI	variable nr 221	Information provided by the B.M.S. Bit nr 7 : Forced operation at low speed
POST_V	variable nr 097	Duration of post-ventilation in seconds
VENT_S	Trigger J1, CLIMATIC board, variable nr 128	Discharge fan
PV	Trigger A8, 8RS2ANA board, variable nr 136	Low speed

Operation of the discharge fan, also called the air handling fan, depends on the following conditions :

- Unit On/Off status
- Post-ventilation status
- High or low speed status

### Low speed

Low speed is an optional feature.

### External contact

Closing input 2.6 on the 24EL board forces fan operation at low speed.

### RS-232 / J-bus

Activation of bit nr 7 of the ORDI variable forces fan operation at low speed.

### Post-ventilation

In the event that one of the compressors or a heating stage is activated the post-ventilation function will force rotation of the fan for 2 minutes after the stop command has been issued.

# COMPRESSOR.

Variables used :

T_EXT	input X2, variable nr 002	Outdoor air temperature
T_BP_G1	input X5, variable nr 005	Evaporating temperature, compressor nr 1
T_BP_G2	input X6, variable nr 006	Evaporating temperature, compressor nr 2
T_BP_G3	input X7, variable nr 007	Evaporating temperature, compressor nr 3
T_BP_G4	input X8, variable nr 008	Evaporating temperature, compressor nr 4
DEGI	variable nr 079	Number of the compressor currently on defrost
ANTICC1	variable nr 104	Time in minutes since start-up of compressor nr 1
ANTICC2	variable nr 105	Time in minutes since start-up of compressor nr 2
ANTICC3	variable nr 106	Time in minutes since start-up of compressor nr 3
ANTICC4	variable nr 107	Time in minutes since start-up of compressor nr 4
COMP_G1	Trigger J2 CLIMATIC board, variable nr 129	Compressor unit nr 1
COMP_G2	Trigger J3 CLIMATIC board, variable nr 130	Compressor unit nr 2
COMP_G3	Trigger J4 CLIMATIC board, variable nr 131	Compressor unit nr 3
COMP_G4	Trigger J5 CLIMATIC board, variable nr 132	Compressor unit nr 4
INJ_G1	Trigger J4 CLIMATIC board, variable nr 131	Hot gas injection, unit nr 1
INJ_G2	Trigger J5 CLIMATIC board, variable nr 132	Hot gas injection, unit nr 2
VENTC12	Trigger J6 CLIMATIC board, variable nr 133	Condenser fan units nr 1 & nr 2
VENTC34	Trigger J7 CLIMATIC board, variable nr 134	Condenser fan units nr 3 & nr 4
VIC_G12	Trigger A9, 8RS2ANA board, variable nr 137	Cycle changeover valve units nr 1 & nr 2
VIC_G34	Trigger A10, 8RS2ANA board, variable nr 138	Cycle changeover valve units nr 3 & nr 4
TOGEL12	variable nr 242	Freeze-up time, in minutes, of compressor nr 1 & nr 2
TOGEL34	variable nr 243	Freeze-up time, in minutes, of compressor nr 3 & nr 4
TO_DEGI	variable nr 244	Time, in minutes, of the defrost cycle

## Anti Short-cycle

The CLIMATIC program includes a function to prevent compressors from being started up too frequently. This totally prohibits compressor start up, even if the control thermostat is calling for cooling, if the time that has elapsed since the previous start up is lower than 6 minutes.

Variables ANTICCx must be at 000 for compressor start up to be authorised.

## Compressor operating time equalisation.

The CLIMATIC program is designed to manage compressor operating time equalisation to within four hours.

## Defrost function

If the three conditions listed below are met for more than 45 minutes, a defrost cycle will be initiated :

- 1° Operation of the unit in heat pump mode.
- 2° Outdoor air temperature lower than +10°C.
- 3° Compressor suction temperature lower than +2°C

The duration of the cycle is programmed for 2 to 3 minutes, compressor by compressor

If the outdoor air temperature rises back above the +10°C and if the two conditions above were true for 1 minute, a forced defrost cycle is initiated.

## ELECTRIC HEATERS.

Variables used :

PROC	variable nr 076	Heating power factor
REGUL_R	variable nr 108	Request for electric heater start-up
STEP_RC	variable nr 080	Number of electric heat stages
CHAU_1	Trigger A11, 8RS2ANA board, variable nr 139	1st stage electric heat
CHAU_2	Trigger A12, 8RS2ANA board, variable nr 140	2nd stage electric heat

The number of stages of backup heating, electric resistance heaters or gas burners, requested by the control depends on the heating power factor.

## OUTDOOR AIR DAMPER.

Variables used :

DISPO_V	variable nr 112	Availability of an outdoor air damper
REGUL_V	variable nr 111	Opening of the outdoor air damper
VOLET	Signal 0-10V AN1, 8RS2ANA board, variable nr 122	Proportional air damper

### Minimum outdoor air adjustment

The minimum opening value of the outdoor air damper is adjustable via a setpoint. This value is expressed directly as a percentage.

The setpoint can be replaced by the action of a remote potentiometer, from 0% to 100%, an option that can be wired into input X15 of the CLIMATIC control.

### Free-Cooling

If the outdoor air temperature is lower than the conditioned space temperature and if enthalpy control authorises it, cooling can be ensured by proportional opening of the outdoor air damper, providing an Economiser function.

## PROPORTIONAL VALVE, COOLING, CHILLED WATER COIL

Variables used :

PROF	variable nr 075	Cooling power factor
REGUL_F	variable nr 109	Opening of the proportional valve for cooling
VANNE	Signal 0-10V AN0 board 8RS2ANA, variable nr 121	Proportional cooling or heating valve
CHOFROI	Trigger A15 board 8RS2ANA, variable nr 143	Inversion of proportional cooling or heating valve

The percentage the valve is opened by depends on the cooling power factor.

## PROPORTIONAL VALVE, HEATING, HOT WATER HEATING COIL OR TRIAC

Variables used :

PROC	variable nr 076	Heating power factor
REGUL_C	variable nr 110	Opening of the proportional heating valve
VANNE	Signal 0-10V AN0 board 8RS2ANA, variable nr 121	Proportional cooling or heating valve
CHOFROI	Trigger A15 board 8RS2ANA, variable nr 143	Inversion of proportional cooling or heating valve

The percentage the valve is opened by depends on the heating power factor

## HUMIDIFIER.

Variables used :

STEP_HU	variable nr 086	Humidification function
HUMIDIF	Trigger A13 board 8RS2ANA, variable nr 141	Humidifier

Humidifier action depends on the CLIMATIC control.

## INCIDENT CODES.

000	No incidents	
001	Incorrect airflow	24EL 0.5
003	Extraction fan or condenser fan (M) default	24EL 0.2
004	Clogged filters	24EL 0.6
011	Electric heater default	24EL 0.1
012	Discharge air overtemperature	X4
014	Default on gas burner nr 1	24EL 1.0
015	Default on gas burner nr 2	24EL 1.1
017	Gas heat exchanger overtemperature	24EL 1.3
022	Discharge air under temperature	X4
041	Pump default (X)	24EL 0.4
081	Faulty return air or room temperature sensor	X0
083	Faulty discharge air temperature sensor	X4
084	Faulty outdoor air temperature sensor	X2
089	Inter-board link default	J9
091	Fan default ( <i>KVS safety chain</i> )	24EL 0.0
094	Customer specific default contact	24EL 2.7
095	Water leakage or dehumidifier default	24EL 1.2
096	Condenser water under temperature	X13
097	Condenser water overtemperature	X13
098	Water flow default	X13
099	Smoke detection	24EL 0.7
115	High pressure default on compressor nr 1 or condenser fans	X9 or 24EL 0.2
116	Discharge overtemperature default on compressor nr 1	X9
117	Low pressure default on compressor nr 1	X5
125	High pressure default on compressor nr 2 or condenser fans	X10 or 24EL 0.2
126	Discharge overtemperature default on compressor nr 2	X10
127	Low pressure default on compressor nr 2	X6
135	High pressure default on compressor nr 3 or condenser fans	X11 or 24EL 0.3
136	Discharge overtemperature default on compressor nr 3	X11
137	Low pressure default on compressor nr 3	X7
145	High pressure default on compressor nr 4 or condenser fans	X12 or 24EL 0.3
146	Discharge overtemperature default on compressor nr 4	X12
147	Low pressure default on compressor nr 4	X8



**001****Incorrect airflow.***board input 0.5; Pressure switch SP6*

## Variables used :

P_DA	input 0.5 24EL, variable nr 037	Airflow pressure switch contact status
DEF_VS	variable nr 227	fan safety device monitoring
TO_VS	variable nr 235	Bit nr 1 : Airflow pressure switch Airflow cut-out counter

If the contact on the airflow safety pressure switches closes for more than 20 seconds, and the discharge air fan has been running for more than 1 minute 30 seconds, the airflow safety function is activated and the fans are shut down. Incident code **001** is displayed, the general default contact is activated.

The airflow safety function automatically resets itself 1 minute 30 seconds after it has tripped.

This safety condition is held if it happens 3 times in the same day, in which case reset must be done manually. Cut-out counters are reset to zero every evening at 20h.00 if there has been no more than 3 cut-outs.

**003****Extraction and condensing fan default***24EL board 0.2; KVC*

## Variables used :

AUX_VC12	input 0.2 24EL, variable nr 034	condenser fan auxiliary contact status
DEF_CD	variable nr 233	condenser safety device monitoring
		Bit nr 0 : condenser fans

On 'M' type units, a single fan is used for condensing and extraction.

The fan contactor has not cut in despite a request from the CLIMATIC control.

The fan motor thermal safety device *ST36* is open

The thermal protection devices on the condenser fan motors act directly on the condenser fan motor contactors. Information is relayed to the CLIMATIC through the auxiliary contacts on the contactors.

If the CLIMATIC commands fan operation and, five seconds later, the auxiliary contact is still open, condenser fan protection is activated and stops the fans and compressors concerned. Incident code **003** is displayed, the general default contact is activated.

This safety trip out is maintained, and manual reset is mandatory.

**004****Clogged filter information.***24EL board 0.6; pressure switch SP5*

## Variables used :

P_FIL	input 0.6 24EL, variable nr 038	filter pressure switch contact status
DEF_VS	variable nr 227	fan safety device monitoring
		Bit nr 0 : Filter pressure switch

If the filter pressure switch opens for more than 1 minute, the CLIMATIC generates a filter dirty default. Incident code **004** is displayed, the general default signal contact is activated, the unit does not shut down.

**Discharge air temperature safety***CLIMATIC X4; BT14; ST41*

## Variables used :

ST_SOUF	variable nr 225	Discharge air temperature safety
		Bit nr 0 : 1° level high limit
		Bit nr 1 : 1° level low limit
		Bit nr 2 : 2° level low limit
		Bit nr 3 : 3° level low limit
		Bit nr 4 : 2° level low limit
TO_SOUF	variable nr 234	low level limit default counter
		(255u in the case of antifreeze th'stat cut-out)

**High air discharge temperature limit****1st safety level**

If the air discharge temperature is +40°C or more, heating regulation stages off progressively. The regulation cycle picks up and operates normally once the temperature has dropped back to less than 35°C.

**012****2nd safety level**

If the air discharge temperature is +60°C or greater, the safety thermostat is activated. This safety device resets itself automatically when the temperature drops back under 55°C. Incident code 012 is displayed, the general default contact is activated.

**Low air discharge temperature limit****1st safety level**

If the air discharge temperature is +10°C or lower, cooling regulation is progressively staged off. The regulation cycle picks up and operates normally once the temperature has risen above 15°C.

**2nd safety level**

If the discharge air temperature is +8°C or lower, the Roof-Top automatically positions its outdoor air damper into the 100% return air position. This safety level is cleared when the temperature rises above +12°C.

**022****3rd safety level**

If the discharge air temperature is +2°C or lower for more than 15 minutes and 15 minutes after start up of the ventilation, the low discharge air temperature safety thermostat opens and the Roof-Top unit is completely shut down. Incident code 022 is displayed, the general default contact is activated.

This safety protection is cleared when the temperature rises above +15°C. In addition, the fault condition is maintained if the fault occurs three times in the same day, in which case the unit has to be reset manually. This default counter is reset every day at 20.00h if the number of counts has not exceeded 3.

Note: On a Roof-top unit equipped with a hot water heating coil, the temperature limit threshold is set at +6°C and the delay before fault recognition is 5 seconds. In addition, if the antifreeze protection thermostat trips, the 3<sup>rd</sup> safety level is immediately adopted and held, and the thermostat then the CLIMATIC control have to be manually reset.

**011****Electric resistance heater default**

24EL board 0.1; KR1, KR2, ST2, ST3, ST4

## Variables used :

AUX_RE	input 0.1 24EL, variable nr 033	Electric resistance heater auxiliary contact status
DEF_RE	variable nr 228	resistance heater safety device monitoring Bit nr 0 : Heater thermal protection

Electric resistance heater safety thermostats (or Klixon), act directly on the heater stage contactors. This information is relayed to the CLIMATIC control by the contactor auxiliary contacts. If the CLIMATIC control commands operation of the electric resistance heaters and if 5 seconds later the auxiliary contact is still open, the electric heater safety function is activated and cuts out all electric heaters. Incident code 011 is displayed, the general default contact is activated. This safety trip out is maintained, and manual reset is mandatory.

Note: This default is also displayed if the contactor auxiliary contacts are « shunted ».

**014****Gas burner default**

24EL board 1.0 & 1.1; RDB1, RDB2

**015**

## Variables used :

D_BRUL1	input 1.0 24EL, variable nr 040	Default relay, control block, 1st gas burner
D_BRUL2	input 1.1 24EL, variable nr 041	Default relay, control block, 2nd gas burner
DEF_RE	variable nr 228	heater safety device monitoring Bit nr 1 : 1st gas burner default Bit nr 2 : 2nd gas burner default

If the default relay on the gas burner control blocks opens, the heater safety function is activated and the burner concerned is shut down. Incident code 014 or 015 is displayed, the general default contact is activated.

This safety function resets itself automatically on the CLIMATIC control, but the control block on the burner must be reset manually.

**017****Gas heat exchanger overtemperature**

24EL board 1.3; RTTH

Variables used :

D_ECHAN	input 1.3 24EL, variable nr 043	Heat exchanger thermostat status
DEF_RE	variable nr 228	heater safety device monitoring
		Bit nr 4 : Gas heat exchanger thermostat

If the safety thermostat located on the heat exchanger opens, the heater safety function is activated and the gas burners are shut down. Incident code **017** is displayed, the general default contact is activated.

This safety trip out is maintained, and manual reset is mandatory.

**041**

#### **Pump default**

24EL board 0.4; KP

Variables used :

AUX_P	input 0.4 24EL, variable nr 036	circulating pump auxiliary contact
DEF_CD	variable nr 233	condenser safety device monitoring
		Bit nr 5 : circulating pump, system X

The thermal protection device on the circulating pump, acts directly on the pump contactor. This information is relayed to the CLIMATIC control by the auxiliary contact on the contactor.

If the CLIMATIC control commands pump operation and 5 seconds later, the auxiliary contact is still open, the condenser safety function is activated and stops the pump. Incident code **041** is displayed, the general default contact is activated.

This safety trip out is maintained, and manual reset is mandatory.

Note: This default is also displayed if the contactor auxiliary contacts are « shunted ».

#### **Sensor status**

**081**

Room thermostat missing or defective.

CLIMATIC X0; BT10

**083**

Discharge air thermostat defective.

CLIMATIC X4; BT14

**084**

Outdoor air thermostat defective.

CLIMATIC X2;

Variables used :

S_SONDE	variable nr 224	Bit nr 0 for the outdoor air temperature sensor
		Bit nr 1 for the discharge air temperature sensor
		Bit nr 2 for the indoor air temperature sensor

The absence or defective operation of the conditioned space sensor, discharge air sensor or outdoor air sensor can cause incorrect operation of the control system. In this case, a safety device trips and all components are stopped with the exception of the fans. Incident code **081** for the conditioned space sensor, **083** for the discharge air sensor and **084** for the outdoor air temperature sensor, is displayed; the general default contact is activated.

**089**

#### **Inter-board link default**

CLIMATIC J9;

Variables used :

NCAR	variable nr 165	Number of the CLIMATIC board
PRECAR	variable nr 166	Presence of linked boards

The inter-board link is missing or defective.

**091**

#### **Fan default**

24EL board 0.0; KVS

Variables used :

AUX_VS	input 0.0 24EL, variable nr 032	Fan contactor auxiliary contact status
DEF_VS	variable nr 227	fan safety device monitoring
		Bit nr 2 : Fan contactor

Fan contactor contacts have not made when the CLIMATIC demands fan operation.

- The fire safety thermostat, or fire safety insert, has opened. *ST1, terminals 11 & 12*
- One of the « Klinox » on the electric resistance heaters has opened. *ST2, ST3 & ST4*
- The thermal protection device on the air handling fan has tripped. *ST5*

The fire safety thermostat, the fan motor thermal protection device, and the electric heater

protection thermostats (Klixons) all act directly on the fan motor contactor. This information is transmitted to the CLIMATIC control by the contactors auxiliary contact.  
 If the CLIMATIC control gives the command for fan operation and 5 seconds later, the auxiliary contact is still open, the fan safety protection cuts in and the entire Roof-Top unit is shut down. Incident code **091** is displayed, the general default contact is activated.  
 This safety trip out is maintained, and manual reset is mandatory.

If the Roof-Top unit is equipped with a servo-motor driven damper, detection time is increased to 2 minutes.

Note: This incident code will also be displayed if the auxiliary contact is shunted.

**094** **Customer specific default contact**  
*24EL board 2.7;*

Variables used :  
 D\_CLI input 2.7 24EL, variable nr 055 Miscellaneous customer default contact

A default outside the unit has been activated. Incident code **094** is displayed, the general default contact is activated.

**095** **Water leak or humidifier default**  
*24EL board 1.2; RFO, HLK/24*

Variables used :  
 D\_HU\_FO input 1.2 24EL, variable nr 042 Humidifier or water leak default relay

If the contact on the humidifier control board, or if the contact on the leak detection board closes for more than 30 seconds, the CLIMATIC control indicates a default and closes down the humidifier. Incident code **095** is displayed, the general default contact is activated.

**096** **Condenser water under temperature**  
*CLIMATIC X13; BT44*

Variables used :  
 T\_EAU input X13, variable nr 013 Water circuit temperature  
 DEF\_CD variable nr 233 condenser safety device monitoring  
 Bit nr 2 : water circuit under temperature  
 TO\_SEAU variable nr 240 Water circuit temperature default counter

If the water circuit temperature drops below +4°C during operation of one of the compressors, the condenser safety function is activated, the compressors are shut down. Incident code **096** is displayed, the general default contact is activated.  
 This safety protection is cleared if the if the water loop temperature rises above 8°C. In addition, the fault condition is maintained if the fault occurs three times in the same day, in which case the unit has to be reset manually. This default counter is reset every day at 20.00h if the number of counts has not exceeded 3.

**097** **Condenser temperature overtemperature**  
*CLIMATIC X13; BT44*

Variables used :  
 T\_EAU input X13, variable nr 013 Water circuit temperature  
 DEF\_CD variable nr 233 condenser safety device monitoring  
 Bit nr 3 : water circuit overtemperature  
 TO\_SEAU variable nr 240 Water circuit temperature default counter

If the water circuit temperature rises above +44°C during operation of one of the compressors, the condenser safety function is activated, the compressors are shut down. Incident code **097** is displayed, the general default contact is activated.  
 This safety protection is cleared if the if the water loop temperature drops below 40°C. In addition, the fault condition is maintained if the fault occurs three times in the same day, in which case the unit has to be reset manually. This default counter is reset every day at 20.00h if the number of counts has not exceeded 3.

**098** **Water flow default temperature**  
*CLIMATIC X13; SD1, SD2*

Variables used :  
 DEBIT input X13, variable nr 029 water flow switch contact status  
 DEF\_CD variable nr 233 condenser safety device monitoring  
 Bit nr 4 : water flow switch

TODEBIT variable nr 241

Water flow default counter

If the water flow switch contacts open for more than 20 , the condenser safety function is activated, the compressors are shut down. Incident code **098** is displayed, the general default contact is activated.

This safety protection is cleared if the contacts close for more than 20 seconds. In addition, the fault condition is maintained if the fault occurs three times in the same day, in which case the unit has to be reset manually. This default counter is reset every day at 20.00h if the number of counts has not exceeded 3.

**099**

#### Smoke default

Carte 24EL 0.7; BF1

Variables used :

D_FUMEE	input 0.7 24EL, variable nr 039	smoke detector contact status
DEF_VS	variable nr 227	fan safety device monitoring
		Bit nr 3 : Smoke detection

If the contact provided on the smoke detection board closes, the smoke detection safety function is activated, the unit shuts down completely, the outdoor air damper is driven to the 100% outdoor air position. Incident code **099** is displayed, the general default contact is activated.

This safety trip out is maintained, and manual reset is mandatory.

**115**

#### High pressure safety switch, or condenser fan safety devices.

CLIMATIC X9, X10, X11, X12; SP1, SP2, SP3, SP4

**125**

Carte 24EL 0.2, 0.3; ST36, ST37, ST38, ST39

**135**

Variables used :

**145**

Contact readout. These are declared open if the temperature read is -28.0

T_HP_G1	input X9, variable nr 009	for the 1st compressor
T_HP_G2	input X10, variable nr 010	for the 2nd compressor
T_HP_G3	input X11, variable nr 011	for the 3rd compressor
T_HP_G4	input X12, variable nr 012	for the 4th compressor

High pressure safety switch monitoring. Activation du bit nr 1.

DEF_G1	variable nr 229	for the 1st compressor.
DEF_G2	variable nr 230	for the 2nd compressor.
DEF_G3	variable nr 231	for the 3rd compressor.
DEF_G4	variable nr 232	for the 4th compressor.

Cut-out counter

TOPHP12	variable nr 238	The tens indicate cut-outs on the 2nd compressor The units indicate cut-outs on the 1st compressor
TOPHP34	variable nr 234	The tens indicate cut-outs on the 4th compressor The units indicate cut-outs on the 3rd compressor

AUXVC12	input 0.2 24EL, variable nr 034	condenser fan 1 & 2 auxiliary contact status
AUXVC34	input 0.3 24EL, variable nr 035	condenser fan 3 & 4 auxiliary contact status
DEF_CD	variable nr 233	condenser fan safety device monitoring
		Bit nr 0 : condenser fans, circuits 1 & 2
		Bit nr 1 : condenser fans, circuits 3 & 4

If the contact of the high pressure switch opens and if the compressor has been running for more than 5 seconds, the high pressure safety protection is tripped and the compressor is shut down. Incident code **115, 125, 135 or 145** is displayed, depending on which compressor is concerned, the general default contact is activated.

The compressor will be authorised to start up again as soon as the contact is closed.

This safety condition is held if it happens 3 times in the same day, in which case reset must be done manually. Cut-out counters are reset to zero every evening at 20h.00 if there has been no more than 3 cut-outs.

The thermal protection devices on the condenser fan motors act directly on the condenser fan motor contactors. Information is relayed to the CLIMATIC through the auxiliary contacts on the contactors.

If the CLIMATIC commands fan operation and, five seconds later, the auxiliary contact is still open, condenser fan protection is activated and stops the fans and compressors concerned. Incident code **115, 125, 135 or 145** is displayed, the general default contact is activated.

This safety trip out is maintained, and manual reset is mandatory

**116**

#### Discharge overtemperature protection.

CLIMATIC X9, X10, X11, X12; BT19, BT20, BT21, BT22

126

Variables used:

Temperature monitoring, with its value in units

136

T_HP_G1	input X9, variable nr 009	for the 1st compressor
T_HP_G2	input X10, variable nr 010	for the 2nd compressor
T_HP_G3	input X11, variable nr 011	for the 3rd compressor
T_HP_G4	input X12, variable nr 012	for the 4th compressor

146

Default logged. Activation of bit nr 2.

DEF_G1	variable nr 229	for the 1st compressor
DEF_G2	variable nr 230	for the 2nd compressor
DEF_G3	variable nr 231	for the 3rd compressor
DEF_G4	variable nr 232	for the 4th compressor

If the compressor discharge temperature exceeds 140°C, i.e. 253u, discharge temperature protection is triggered and the compressor is stopped. Incident code 116, 126, 136 or 146 is displayed according to which compressor is concerned, the general default contact is activated. This safety trip out is immediately maintained, and manual reset is mandatory

117

The low pressure switch is, or has been, open.

*CLIMATIC X5, X6, X7, X8; SP11, SP12, SP13, SP14*

127

Variables used:

137

Contact readout. These are declared open if the temperature read is -28.0

T_BP_G1	input X5, variable nr 005	for the 1st compressor
T_BP_G2	input X6, variable nr 006	for the 2nd compressor
T_BP_G3	input X7, variable nr 007	for the 3rd compressor
T_BP_G4	input X8, variable nr 008	for the 4th compressor

147

Cut-out counters

TOPBP12	variable nr 236	The tens indicate cut-outs on the 2nd compressor The units indicate cut-outs on the 1st compressor
TOPBP34	variable nr 237	The tens indicate cut-outs on the 4th compressor The units indicate cut-outs on the 3rd compressor

Default logged. Activation of bit nr 0.

DEF_G1	variable nr 229	for the 1st compressor
DEF_G2	variable nr 230	for the 2nd compressor
DEF_G3	variable nr 231	for the 3rd compressor
DEF_G4	variable nr 232	for the 4th compressor

If the low pressure switch opens and if the compressor has been operating for more than 2 minutes, low pressure safety protection is activated and the compressor is stopped. This safety protection is not taken into account during the defrost cycle on Roof-Top heat pumps.

Incident code 117, 127, 137 or 147 is displayed, depending on which compressor is concerned. The general default contact is activated.

The compressor will be authorised to start up again as soon as the contact is closed. This safety condition is held if it happens 3 times in the same day, in which case reset must be done manually. Cut-out counters are reset to zero every evening at 20h.00 if there has been no more than 3 cut-outs.

## NOTIONS ON OCTETS AND BITS.

All CLIMATIC variables are memorised with one Octet.

An Octet is a computing unit with a value between 0 and 255.  
A (decimal) value of 255 corresponds to a binary value of 11111111.

Relationship between Bits and Octets

nr 7	nr 6	nr 5	nr 4	nr 3	nr 2	nr 1	nr 0
$2^7$	$2^6$	$2^5$	$2^4$	$2^3$	$2^2$	$2^1$	$2^0$
128	064	032	016	008	004	002	001

The value of an octet is equal to its number of active bits, i.e. bits that are « ON », see table above.

- If all eight bits are inactive, ...  
the value of the Octet is 000.
- If bit nr 0 is active and the seven others are inactive,  
the value of the Octet is 001.
- If bits nr 0 and nr 4 are active and the six others are inactive,  
the value of the Octet is 001 + 016 i.e. 017.
- If all eight bits are active,  
the value of the Octet is 001 + 002 + 004 + 008 + 016 + 032 + 064 + 128 i.e. 255.

So, to activate bits nr 0 and nr 1, set the value for the variable to 001 + 002 i.e. 003.

## BOARD LINKS (J9).

### Setpoint setback potentiometer

If the inter-board link is used, a single control box with a potentiometer connected to the unit with CLIMATIC board nr 0 is sufficient, since the other units receive the setback value via the common information bus.

### Enthalpy function.

If the inter-board link is used, a single outdoor air relative enthalpy sensor connected to the unit with CLIMATIC board nr 0 is sufficient, since the other units receive the enthalpy value via the common information bus.

### Zoning.

If the inter-board link is used, the CLIMATIC control calculates the number of units demanding cooling then the number of units demanding heat.

If the number of units demanding cooling is greater than or equal to the number of units demanding heat heating regulation will be inhibited on the latter.

By the same principle, if the number of units demanding heat is greater than the number of units demanding cooling, cooling regulation will be inhibited on the latter.

If there is an inter-board link, a single outdoor air temperature sensor and/or a single room temperature sensor can be connected to the unit equipped with CLIMATIC board Nr 1. The other units receive the corresponding temperature values via the link.

## RS-232 (J11) LINK TO A COMPUTER OR B.M.S.

Some commands, available through potential-free contacts, connected to the 24EL can be triggered via the RS-232 port. These commands can be accessed through the ORDI variable at address 221.

### Note :

To enable the CLIMATIC to take account of the ORDI variable, the following conditions must be satisfied :

Either the B.M.S.variable, at address 220, must be greater than zero.

Or bit nr 7 of the MA\_AR\_D setpoint, setpoint nr 14 address 206, must be active.

The B.M.S. variable enables account to be taken of the validity of the link between the CLIMATIC and the BMS.. The CLIMATIC decrements the GTC variable by one unit every second. The B.M.S. program must periodically regenerate this value. A dropped link or the stoppage of the B.M.S. will result in zeroing the validation variable and return the CLIMATIC to free-standing operation.

### Codes for the ORDI variable, address 221.

- Bit nr 0 : Unoccupied
- Bit nr 1 : Forced occupation
- Bit nr 2 : Electric resistance heater shutdown
- Bit nr 3 : 50% compressor capacity reduction
- Bit nr 4 : 100% compressor capacity reduction
- Bit nr 5 : Heating valve offloading
- Bit nr 6 : Forced operation at minimum outdoor air
- Bit nr 7 : Request for low speed





CLIMATIC		
CONSA	/C	192
MORTE	/K	193
ABAIS	/K	194
TROS_DU	/C	195
TROS_HU	/C	196
T_VOLET	/C	196
T_CHAUD	/C	197
T_FROID	/C	198
T_FR_34	/C	248
ENCL_F	/K	250
DIFET_F	/K	251
ENCL_C	/K	252
DIFET_C	/K	253
HE	/U	146
MN	/U	145
JS	/U	147
RAH	/U	167
DING	/U	249
MINIAIR	/U	199
DV_J	/U	200
FV_J	/U	201
DV_H	/U	202
FV_H	/U	203
P_ANTI	/U	204
ORDI	/U	221
GTC	/U	220
MA_AR_D	/U	206

Write	J-BUS
Required conditioned space temperature	00h
Deadband between heating and cooling	01h
Value of reduction of CONSA for Night mode operation	02h
Dew point temperature for dehumidification	03h
Dew point temperature for dehumidification	04h
Outdoor air T° threshold for free-cooling inhibition	05h
Outdoor air T° threshold for electric heater inhibition	06h
Outdoor air T° threshold for cp cooling inhibition	07h
Ture threshold for compressor 3 & 4 cooling lockout	08h
Cooling regulation cut-in threshold	09h
Cooling regulation differential threshold	0Ah
Heating regulation cut-in threshold	0Bh
Heating regulation differential threshold	0Ch
Hours	30h
Minutes	31h
Day of the week (Sunday = 1)	32h
Clock reset <i>Force once to 255 after each clock reset</i>	33h
Integration time	34h
Minimum % of outdoor air	35h
Time for start of daily unoccupied period	36h
Time for end of daily unoccupied period	37h
Time and day of start of weekly unoccupied period <i>207 = 20.00h. on the 7th day</i>	38h
Time and day of end of weekly unoccupied period <i>082 = 08.00h. on the 2nd day</i>	39h
Gradient for end of unoccupied period anticipation function	3Ah
Component off-loading <i>bit nr 0 : Unoccupied mode bit nr 1 : Forced unoccupied mode bit nr 2 : Electric resistance heater offloading bit nr 3 : 50% compressor capacity reduction bit nr 4 : 100% compressor capacity reduction bit nr 5 : Hot water valve offloading bit nr 6 : Forced operation at minimum outdoor air bit nr 7 : Request for low speed</i> <i>The CLIMATIC program only takes account of these bits if the BMS variable is greater than 0.</i>	3Bh
BMS link validity <i>This must be greater than 0 if the ORDI variable is used. The CLIMATIC program decrements this value by 1 unit per second</i>	3Ch
ON/OFF <i>bit nr 0 : Unit ON/OFF bit nr 1 : Unit control via switch A14 (customer)</i>	3Dh

CLIMATIC		
T_AMB	/C	000
T_EXT	/C	002
T_SOUF	/C	004
T_BP_G1	/C	005
T_BP_G2	/C	006
T_BP_G3	/C	007
T_BP_G4	/C	008

Read	J-BUS
Room or return air temperature	80h
Outdoor air temperature	81h
Discharge air temperature	82h
Evaporator refrigerant temperature, unit 1	83h
Evaporator refrigerant temperature, unit 2	84h
Evaporator refrigerant temperature, unit 3	85h
Evaporator refrigerant temperature, unit 4	86h

T_HP_G1	/C	009
T_HP_G2	/C	010
T_HP_G3	/C	011
T_HP_G4	/C	012
T_EAU	/C	013
H_AMB	/U	017
H_EXT	/U	019
DEGI	/U	079
POST_V	/U	097
VANNE	/U	121
VOLET or HUMID_P	/U	122

Discharge temperature, unit 1	87h
Discharge temperature, unit 2	88h
Discharge temperature, unit 3	89h
Discharge temperature, unit 4	8Ah
Water circuit temperature	8Bh
Conditioned space RH	A0h
Outdoor air RH	A1h
Defrost function = number of compressor currently undergoing defrost	A2h
Duration of post-ventilation after heating (seconds)	A3h
Proportional heating or cooling valve or triac Signal 0-10V / 000 = 0V / 255 = 10V	A4h
Proportional air damper or Proportional signal from Humidifier Signal 0-10V / 000 = 0V / 255 = 10V	A5h

S_SONDE	/U	224
ST_SOUF	/U	225
DEF_VS	/U	227
DEF_RE	/U	228
DEF_G1	/U	229
DEF_G2	/U	230
DEF_G3	/U	231
DEF_G4	/U	232
DEF_CD	/U	233

Sensor status <i>bit nr 0 : Outdoor air sensor faulty</i> <i>bit nr 1 : Discharge air sensor faulty</i> <i>bit nr 2 : Room air sensor faulty</i>	A6h
Discharge air temperature safety <i>bit nr 0 : 1° high level limit</i> <i>bit nr 1 : 1° low level limit</i> <i>bit nr 2 : 2° low level limit</i> <i>bit nr 3 : 3° low level limit (Alarm)</i> <i>bit nr 4 : 2° low level limit (Alarm)</i>	A7h
Discharge fan default <i>bit nr 0 : Filter pressure switch</i> <i>bit nr 1 : Airflow pressure switch</i> <i>bit nr 2 : Fan contactor (Stoptherm, DI)</i> <i>bit nr 3 : Smoke detection</i>	A8h
Electric heater default <i>bit nr 0 : Resistance heater contact (Klixon)</i> <i>bit nr 1 : 1st gas burner default</i> <i>bit nr 2 : 2nd gas burner default</i> <i>bit nr 4 : Gas heat exchanger thermostat</i>	A9h
Compressor NR 1 default <i>bit nr 0 : Low pressure switch</i> <i>bit nr 1 : High pressure switch</i> <i>bit nr 2 : Discharge overtemperature</i>	AAh
Compressor NR 2 default <i>bit nr 0 : Low pressure switch</i> <i>bit nr 1 : High pressure switch</i> <i>bit nr 2 : Discharge overtemperature</i>	ABh
Compressor NR 3 default <i>bit nr 0 : Low pressure switch</i> <i>bit nr 1 : High pressure switch</i> <i>bit nr 2 : Discharge overtemperature</i>	ACH
Compressor NR 4 default <i>bit nr 0 : Low pressure switch</i> <i>bit nr 1 : High pressure switch</i> <i>bit nr 2 : Discharge overtemperature</i>	ADh
Condenser default <i>bit nr 0 : Condenser fans circuit 1 &amp; 2</i> <i>bit nr 1 : Condenser fans circuit 3 &amp; 4</i> <i>bit nr 2 : Water loop under temperature (OR)</i> <i>bit nr 3 : Water loop overtemperature (OR)</i>	AEh

PANNE	/U	255
TO_VS0	/U	176
TO_VS1	/U	177
TO_VS2	/U	178
TO_G10	/U	179
TO_G11	/U	180
TO_G12	/U	181
TO_G20	/U	182
TO_G21	/U	183
TO_G22	/U	184
TO_G30	/U	185
TO_G31	/U	186
TO_G32	/U	187
TO_G40	/U	188
TO_G41	/U	189
TO_G42	/U	190
VENT_S	/L	128
COMP_G1	/L	129
COMP_G2	/L	130
COMP_G3	/L	131
INJ_G1		
COMP_G4	/L	132
INJ_G2		
VENTC12	/L	133
VENTC34	/L	134
ALARME	/L	135
PV	/L	136
VIC_G12	/L	137
VIC_G34	/L	138
CHAU_1	/L	139
CHAU_2	/L	140
CHAU_3	/L	141
HUMIDIF		
CLIENT	/L	142
POMPE		
CHOFROI	/L	143
MA_AR	/L	096
VEILLE	/L	098
ANTICIP	/L	099
HORSSEL	/L	100

<i>bit nr 4 : Water flow switch (OR)</i>		
<i>bit nr 5 : Circulating pump (X)</i>		
Incident code		AFh
VENT_S (+1 every minute)		B0h
VENT_S (+1 every 4 hours)		B1h
VENT_S (+1 every 1000 hours)		B2h
COMP_G1 (+1 every minute)		B3h
COMP_G1 (+1 every 4 hours)		B4h
COMP_G1 (+1 every 1000 hours)		B5h
COMP_G2 (+1 every minute)		B6h
COMP_G2 (+1 every 4 hours)		B7h
COMP_G2 (+1 every 1000 hours)		B8h
COMP_G3 (+1 every minute)		B9h
COMP_G3 (+1 every 4 hours)		BAh
COMP_G3 (+1 every 1000 hours)		BBh
COMP_G4 (+1 every minute)		BCh
COMP_G4 (+1 every 4 hours)		BDh
COMP_G4 (+1 every 1000 hours)		BEh
Discharge fan		C0h
Compressor, unit nr 1		C1h
Compressor, unit nr 2		C2h
Compressor, unit nr 3 <i>or</i> Hot gas injection, unit nr 1		C3h
Compressor, unit nr 4 <i>or</i> Hot gas injection, unit nr 2		C4h
Condenser fans, units nr 1 & nr 2		C5h
Condenser fans, units nr 3 & nr 4		C6h
General default signal		C7h
Low speed		C8h
Cycle changeover valve, units nr 1 & nr 2 (HP)		C9h
Cycle changeover valve, units nr 3 & nr 4 (HP)		CAh
1st stage electric heat		CBh
2nd stage electric heat		CCh
3rd stage electric heat <i>or</i> Humidifier		CDh
Misc. customer control <i>or</i> Pump for system X		CEh
Heating or cooling proportional valve changeover		CFh
Unit ON/OFF status		D0h
Unoccupied function		D1h
End of unoccupied period anticipation function		D2h
Building frost protection function		D3h

## VARIABLES.

0	T0	T_AMB	C	Conditioned space or return air temperature
2	T2	T_EXT	C	Outdoor air temperature
4	T4	T_SOUF	C	Discharge air temperature
5	T5	T_BP_G1	C	Evaporator refrigerant temperature, unit 1
6	T6	T_BP_G2	C	Evaporator refrigerant temperature, unit 2
7	T7	T_BP_G3	C	Evaporator refrigerant temperature, unit 3
8	T8	T_BP_G4	C	Evaporator refrigerant temperature, unit 4
9	T9	T_HP_G1	C	Discharge temperature, unit 1
10	T10	T_HP_G2	C	Discharge temperature, unit 2
11	T11	T_HP_G3	C	Discharge temperature, unit 3
12	T12	T_HP_G4	C	Discharge temperature, unit 4
13	T13	T_EAU	C	Water circuit temperature
15	T15	LOCAL	L	Local / Remote button on display
16	X0	X0	U	Conditioned space or return air temperature
17	X1	H_AMB	U	Conditioned space air RH
19	X3	H_EXT	U	Outdoor air RH
29	X13	DEBIT	L	Water flow switch
30	X14	POTTEMP	U	Temperature offset potentiometer (4-20 mA)
32	NV0	AUX_VS	L	Discharge fan contactor auxiliary contact
33	NV1	AUX_RE	L	Electric heater contactor auxiliary contact
34	NV2	AUXVC12	L	Condenser 1 & 2 fan contactor auxiliary contact
35	NV3	AUXVC34	L	Condenser 3 & 4 fan contactor auxiliary contact
36	NV4	AUX_P	L	Pump contactor auxiliary contact
37	NV5	P_DA	L	Airflow pressure switch
38	NV6	P_FIL	L	Clogged filter pressure switch
39	NV7	D_FUMEE	L	Smoke detector
40	NV8	D_BRUL1	L	1st burner default relay
41	NV9	D_BRUL2	L	2nd burner default relay
42	NV10	D_HU_FO	L	Water leakage or humidifier default relay
43	NV11	D_ECHAN	L	Exchanger overheat protection default relay
44	NV12	MA_50	L	50% compressor offloading switch
45	NV13	MA_100	L	100% compressor offloading switch
46	NV14	MA_RE	L	100% electric heat offloading switch
47	NV15	MA_BEC	L	Hot water valve offloading switch
48	NV16	C_VEIL	L	Unoccupied mode forcing switch
49	NV17	C_RELAN	L	Forced re-start initiation switch
50	NV18	C_RNEUF	L	100% outdoor air forcing switch
51	NV19	C_RRECY	L	100% recycled air forcing switch
52	NV20	C_RMINI	L	Minimum outdoor air forcing switch
53	NV21	C_NUIT	L	Night mode forcing switch
54	NV22	C_PV	L	Low speed switch
55	NV23	D_CLI	L	Customer misc. defaults
66	N2	CONSA_A	C	Real value of conditioned space temperature setpoint
67	N3	CONSA_S	C	Real value of discharge air temperature setpoint
68	N4	CH_FR	L	Heating Cooling control
69	N5	MAXI_F	U	Maximum number of cooling control stages. Conditioned space.
70	N6	MAXI_C	U	Maximum number of heating control stages. Conditioned space.
75	N11	PROF	U	Cooling control power factor
76	N12	PROC	U	Heating control power factor
77	N13	STEP_GF	U	Number of compressor stages for cooling operation
78	N14	STEP_GC	U	Number of compressor stages for heating operation
79	N15	DEGI	U	Defrost function
80	N16	STEP_RC	U	Number of electric heat stages
81	N17	C_NMI	U	NMI contact
82	N18	TO_NMI	U	NMI block cut-out counters
83	N19	ENTHA	L	Enthalpy control function
85	N21	STEP_DU	L	Dehumidification function
86	N22	STEP_HU	U	Humidification function
90	N26	FLAG	L	Calculation variable
96	V0	MA_AR	L	Unit on/off status
97	V1	POST_V	U	Post-ventilation after heating (seconds)
98	V2	VEILLE	L	Standby function
99	V3	ANTICIP	L	Anticipation function for end of standby

100	V4	<b>HORSGEL</b>	L	Building frost protection function
101	V5	<b>OK_AIR</b>	L	Correct airflow status
102	V6	<b>REGUL_G</b>	U	Request for unit start-up
104	V8	<b>ANTICC1</b>	U	Anti short-cycle function, unit nr 1
105	V9	<b>ANTICC2</b>	U	Anti short-cycle function, unit nr 2
106	V10	<b>ANTICC3</b>	U	Anti short-cycle function, unit nr 3
107	V11	<b>ANTICC4</b>	U	Anti short-cycle function, unit nr 4
108	V12	<b>REGUL_R</b>	U	Request for electric heat start-up
109	V13	<b>REGUL_F</b>	U	Opening of the proportional valve for cooling
110	V14	<b>REGUL_C</b>	U	Opening of the proportional valve for heating
111	V15	<b>REGUL_V</b>	U	Opening of outdoor air damper
112	V16	<b>DISPO_V</b>	L	Availability of the outdoor air damper
113	V17	<b>DISPO_G</b>	L	Availability of the hygiene sensor
114	V18	<b>REGUL_S</b>	U	Request for fan start-up
115	V19	<b>TT_SOUF</b>	L	Working variable
116	V20	<b>FG_SOUF</b>	L	Variable for display
119	V23	<b>LEC</b>	L	Variable for display
121	AN0	<b>VANNE</b>	U	Proportional heating or cooling valve or triac
122	AN1	<b>VOLET</b>	U	Proportional air damper
128	A0	<b>VENT_S</b>	L	Discharge fan
129	A1	<b>COMP_G1</b>	L	Compressor unit nr 1
130	A2	<b>COMP_G2</b>	L	Compressor unit nr 2
131	A3	<b>COMP_G3</b>	L	Compressor unit nr 3
132	A4	<b>COMP_G4</b>	L	Compressor unit nr 4
133	A5	<b>VENTC12</b>	L	Condenser fans unit nr 1 & nr 2
134	A6	<b>VENTC34</b>	L	Condenser fans unit nr 3 & nr 4
135	A7	<b>ALARME</b>	L	General default
136	A8	<b>PV</b>	L	Low speed
137	A9	<b>VIC_G12</b>	L	Cycle changeover valve units nr 1 & nr 2
138	A10	<b>VIC_G34</b>	L	Cycle changeover valve units nr 3 & nr 4
139	A11	<b>CHAU_1</b>	L	1st stage electric heat
140	A12	<b>CHAU_2</b>	L	2nd stage electric heat
141	A13	<b>HUMIDIF</b>	L	Humidifier
142	A14	<b>CLIENT</b>	L	Customer misc. control
143	A15	<b>CHOFROI</b>	L	Inversion of proportional heating or cooling valve
150	NCARS	<b>NCARS</b>	U	CLIMATIC board number (RS-232)
165	NCAR	<b>NCAR</b>	U	CLIMATIC board number (inter-board link)
166	PRECAR	<b>PRECAR</b>	U	Presence of linked boards
176	TO00	<b>TO_VS0</b>	U	VENT_S (+1 every minute)
177	TO01	<b>TO_VS1</b>	U	VENT_S (+1 every 4 hours)
178	TO02	<b>TO_VS2</b>	U	VENT_S (+1 every 1000 hours)
179	TO10	<b>TO_G10</b>	U	COMP_G1 (+1 every minute)
180	TO11	<b>TO_G11</b>	U	COMP_G1 (+1 every 4 hours)
181	TO12	<b>TO_G12</b>	U	COMP_G1 (+1 every 1000 hours)
182	TO20	<b>TO_G20</b>	U	COMP_G2 (+1 every minute)
183	TO21	<b>TO_G21</b>	U	COMP_G2 (+1 every 4 hours)
184	TO22	<b>TO_G22</b>	U	COMP_G2 (+1 every 1000 hours)
185	TO30	<b>TO_G30</b>	U	COMP_G3 (+1 every minute)
186	TO31	<b>TO_G31</b>	U	COMP_G3 (+1 every 4 hours)
187	TO32	<b>TO_G32</b>	U	COMP_G3 (+1 every 1000 hours)
188	TO40	<b>TO_G40</b>	U	COMP_G4 (+1 every minute)
189	TO41	<b>TO_G41</b>	U	COMP_G4 (+1 every 4 hours)
190	TO42	<b>TO_G42</b>	U	COMP_G4 (+1 every 1000 hours)
192	CO0	<b>CONSA</b>	C	Requested conditioned space temperature
193	CO1	<b>MORTE</b>	K	Dead-band between cooling and heating
194	CO2	<b>ABAIS</b>	K	Value of the reduction of CONSA for Night operation
195	CO3	<b>TROS_DU</b>	C	Dew point temperature for dehumidification
196	CO4	<b>T_VOLET</b>	C	Outdoor air temp. threshold for free cooling inhibition
197	CO5	<b>T_CHAUD</b>	C	Outdoor air temp. threshold for electric heat inhibition
198	CO6	<b>T_FROID</b>	C	Outdoor air temp. threshold for compressor inhibition
199	CO7	<b>MINIAIR</b>	U	Minimum % of outdoor air
200	CO8	<b>DV_J</b>	U	Time of start of daily unoccupied period
201	CO9	<b>FV_J</b>	U	Time of end of daily unoccupied period

202	CO10	DV_H	U	Time and day of start of weekly unoccupied period
203	CO11	FV_H	U	Time and day of end of weekly unoccupied period
204	CO12	P_ANTI	U	Ramp for end of unoccupied period anticipation function
205	CO13	FRIMAIR	U	Control parameters
206	CO14	MA_AR_D	U	On/OFF
207	CO15	INIT	U	Initialisation function
208	CM0	MPOTART	K	Transmitted temperature potentiometer
209	CM1	MPOTARA	U	Potentiometer for transmitted minimum outdoor air setting
210	CM2	MT_ECO	U	Transmitted enthalpy function
211	CM3	T_EXT_C	C	Transmitted outdoor air temperature
212	CM4	ZONE_0	U	rt nr 0 (0) no cooling no heating (1) cooling (2) heating
213	CM5	ZONE_1	U	rt nr 1 (0) no cooling no heating (1) cooling (2) heating
214	CM6	ZONE_2	U	rt nr 2 (0) no cooling no heating (1) cooling (2) heating
215	CM7	ZONE_3	U	rt nr 3 (0) no cooling no heating (1) cooling (2) heating
216	CM8	ZONE_4	U	rt nr 4 (0) no cooling no heating (1) cooling (2) heating
217	CM9	ZONE_5	U	rt nr 5 (0) no cooling no heating (1) cooling (2) heating
218	CM10	ZONE_6	U	rt nr 6 (0) no cooling no heating (1) cooling (2) heating
219	CM11	ZONE_7	U	rt nr 7 (0) no cooling no heating (1) cooling (2) heating
220	CM12	GTC	U	B.M.S. dialogue confirmation
221	CM13	ORDI	U	Component offloading (binary) by the B.M.S.
222	CM14	NBC	L	Inter-board variable
223	CM15	NBCM	U	Inter-board variable
224	IN0	S_SONDE	U	Sensor status
225	IN1	ST_SOUF	U	Discharge air safety
226	IN2	S_DA	L	Airflow safety
227	IN3	DEF_VS	U	Discharge fan default
228	IN4	DEF_RE	U	Crankcase heater default
229	IN5	DEF_G1	U	Compressor nr 1 default
230	IN6	DEF_G2	U	Compressor nr 2 default
231	IN7	DEF_G3	U	Compressor nr 3 default
232	IN8	DEF_G4	U	Compressor nr 4 default
233	IN9	DEF_CD	U	Condenser default
234	IN10	TO_SOUF	U	Low discharge air temperature default cut-out counter
235	IN11	TO_VS	U	Discharge fan default cut-out counter
236	IN12	TOPBP12	U	Low pressure cut-out counter unit nr 1 & nr 2
237	IN13	TOPBP34	U	Low pressure cut-out counter unit nr 3 & nr 4
238	IN14	TOPHP12	U	High pressure cut-out counter unit nr 1 & nr 2
239	IN15	TOPHP34	U	High pressure cut-out counter unit nr 3 & nr 4
240	IN16	TO_SEAU	U	Exchanger temperature default cut-out counter
241	IN17	TODEBIT	U	Water flow default cut-out counter
242	IN18	TOGEL12	U	Freeze-up time on compressors nr s 1 & 2
243	IN19	TOGEL34	U	Freeze-up time on compressors nr s 3 & 4
244	IN20	TO_DEGI	U	Defrost cycle duration
245	IN21	TO_RST	U	Re-start counter
246	IN22	MODE_RT	U	Configuration setpoint
247	IN23	M_VOLET	C	Maximum OAT setpoint for Free-Cooling lockout
248	IN24	T_FR_34	C	OAT setpoint for compressor 3&4 lockout
249	IN25	DING_A	U	Integration time setpoint
250	IN26	ENCL_F	K	Cooling control cut-in threshold setpoint
251	IN27	DIFET_F	K	Cooling control differential threshold setpoint
252	IN28	ENCL_C	K	Heating control cut-in threshold setpoint
253	IN29	DIFET_C	K	Heating control differential threshold setpoint
254	IN30	AFFICHE	U	Variable for display
255	IN31	PANNE	U	Incident code

# DISPLAY.

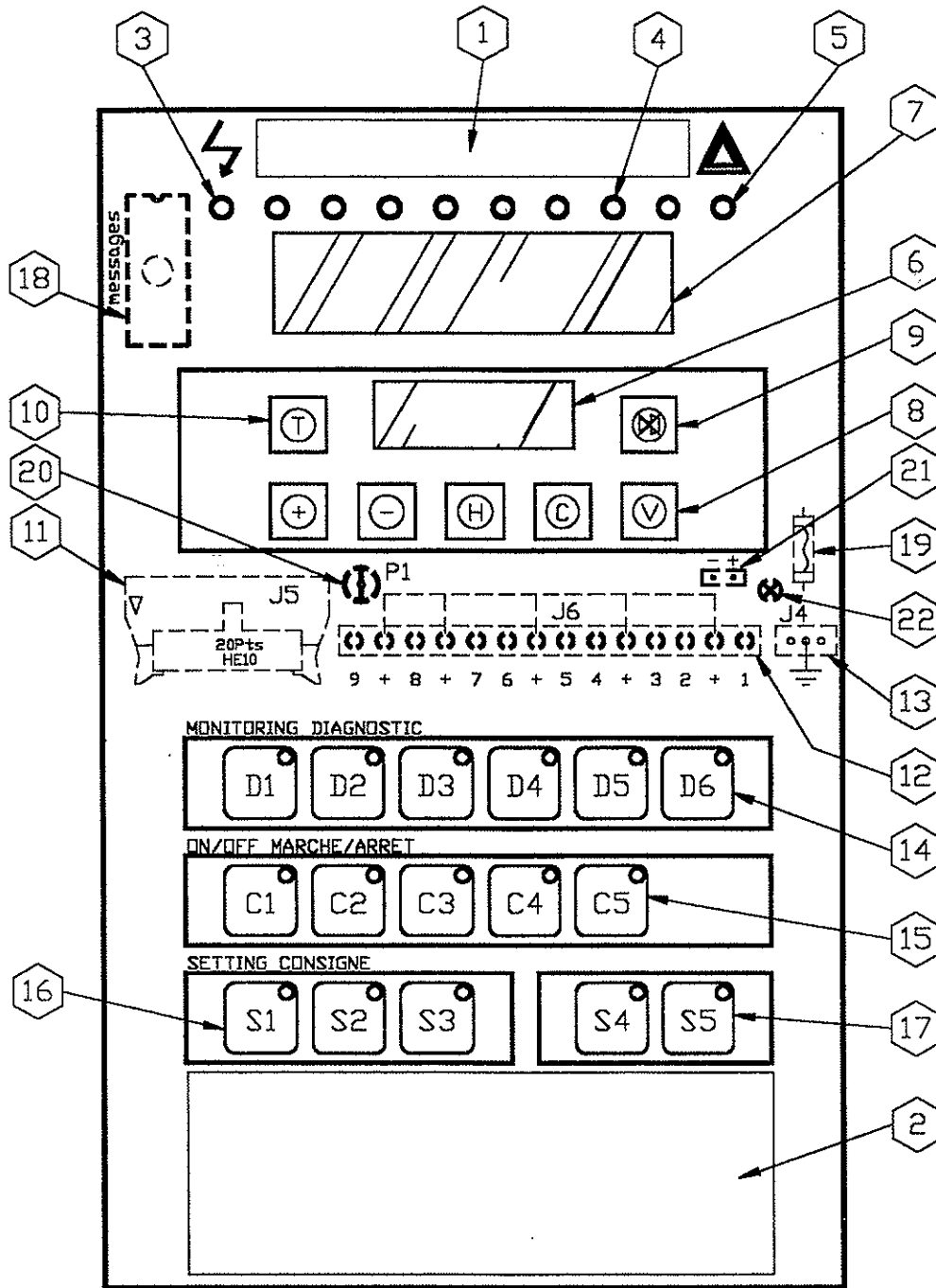

## LEGEND :

- [ 1 ] Green LED description leaflet, *removable from the rear.*
- [ 2 ] Keys D1 to D6, C1 to C5 & S1 to S5 description leaflet, *removable from the rear.*
- [ 3 ] Yellow « power on » LED
- [ 4 ] Eight green LEDs
- [ 5 ] Red default LED
- [ 6 ] Digital display
- [ 7 ] Alpha-digital display, *describes the value displayed on the digital display.*
- [ 8 ] CLIMATIC function keys, *see page 2.*
- [ 9 ] Buzzer clearing key, *the buzzer is an option.*



- 10 Language change, *Two languages are available : French or English.*
- 11 20 pin CLIMATIC connector on the rear.
- 12 Nine potential-free contacts for the eight green LEDs and the red LED.
- 13 12 VAC power connector
- 14 Six keys for the offloading functions.
- 15 Five shortcut keys for calling up setpoints.
- 16 Three function keys for Start-Stop-Standby.
- 17 Two keys, one for resetting the safety devices, the other for selecting Remote/Local mode.

**Selecting the Remote mode deactivates keys 14 15 16 and their functions are no longer taken into account by the CLIMATIC program.**

- 18 Message and key configuration EPROM
- 19 Slow-Blow 1A fuse protecting green LEDs and lighting for the two LCD displays.
- 20 Alpha-digital display contrast adjustment potentiometer, on rear side.
- 21 Two-pin connector for the buzzer, on the rear side (option).

Before replacing the display, recover the message EPROM from the old display, as well as the description leaflets.

The leaflets are located behind the removable panels at the rear of the display.

If there is no display, check the power supply to the CLIMATIC. The display power supply is used only for the LCD display and the 10 LEDs on the upper section of CL 07.

## DEFINITION OF INCIDENT CODES FOR ROOFTOP, MODUL'AIR, CAT AND ORD UNITS.

000	No defaults	RT	MA	CAT	ORD
-----	-------------	----	----	-----	-----

### Airflow defaults PAN\_DA

001	Incorrect airflow	RT	MA		ORD
004	Clogged filters	RT	MA		ORD

### Heating defaults PAN\_C

011	Electric heating coil default	RT	MA		ORD
012	Discharge air overtemperature	RT	MA		ORD
013	Return or room air under temperature				ORD
014	Default on gas burner nr 1	RT			
015	Default on gas burner 2	RT			
016	Default on gas burner 3	RT			
017	Gas heat exchanger overtemperature	RT			

### Mechanical cooling defaults PAN\_F

022	Discharge air under temperature	RT	MA		ORD
023	Return or room air overtemperature				ORD

### Humidity defaults PAN\_H

031	Humidifier default				ORD
032	Return air relative humidity too low				ORD
033	Return air relative humidity too high				ORD

### C.A.T. specific defaults PAN\_CAT

041	Default, pump nr 1 or nr 2 circuit nr 1			CAT	
042	Default, pump nr 3 or nr 4 circuit nr 2			CAT	
043	Default, pump nr 5 or nr 6 circuit nr 3			CAT	
044	Domestic hot water circulating pump default			CAT	
045	Regulated water circuit circulating pump default			CAT	
046	Default indicator, boiler nr 1			CAT	
047	Default indicator, boiler nr 2			CAT	
048	Boiler water level default			CAT	
049	Retention tank level default			CAT	
051	Temperature too low, circuit nr 1			CAT	
052	Temperature too low, circuit nr 2			CAT	
053	Temperature too low, circuit nr 3			CAT	
054	Temperature too low, domestic hot water circuit			CAT	
055	Temperature too low, boiler circuit			CAT	

### Miscellaneous defaults PAN\_D

071	Temperature sensor default, water loop outlet nr 1			CAT	
072	Temperature sensor default, water loop outlet nr 2			CAT	
073	Temperature sensor default, water loop outlet nr 3			CAT	
074	Temperature sensor default, domestic hot water outlet			CAT	
075	Temperature sensor default, boiler return water			CAT	
076	Temperature sensor default, boiler leaving water			CAT	
081	Temperature sensor default, return air or room air	RT	MA		ORD
082	Humidity sensor default, return air RH				ORD
083	Temperature sensor default, discharge air	RT	MA		ORD
084	Temperature sensor default, outdoor air	RT	MA	CAT	
085	Temperature sensor default, chilled water				ORD

086	Temperature sensor default, hot water				ORD
089	Inter-board link default	RTw			
091	Ventilation default (Firestat, Stop therms, no 24V power supply)	RT	MA		ORD
092	Fan thermal safety cut-out on 1st condenser or cooling tower				ORD
093	Fan thermal safety cut-out on 2nd condenser or pump				ORD
094	Customer specific default contact	RT	MA		
095	Water leakage default				ORD
096	Condenser water temperature too low	RT	MA		
097	Condenser water overtemperature	RT	MA		
098	Humidifier or water flow default	RT	MA		
099	Smoke default	RT	MA		

Compressor defaults PAN\_1 PAN\_2 PAN\_3 PAN\_4

*1n1 : n = number of the compressor concerned*

1n1	Discharge temperature sensor faulty				ORD
1n2	Subcooling temperature sensor faulty				ORD
1n3	Evaporator refrigerant temperature sensor faulty				ORD
1n4	Tripped internal electric motor protection				ORD
1n5	High pressure default	RT	MA		ORD
1n6	Discharge overtemperature	RT	MA		ORD
1n7	Low pressure default	RT	MA		ORD
1n8	Refrigeration circuit empty				ORD

Les caractéristiques techniques et spécifications figurant dans cette notice sont données à titre indicatif.  
Le constructeur se réserve le droit de les modifier sans préavis ni obligation pour lui de modifier  
identiquement les versions déjà énumérées.

*The specifications and technical characteristics in this booklet are given for information purposes. The  
manufacturer reserves the right to modify them without prior notice or obligation to modify in a similar  
manner, the exceptions previously supplied.*

Réf : CLIM\_RTV3/Anglais/12-97

# **LENNOX®**

---

**LENNOX France - Z.I. LES MEURIERES - BP 71 - 69780 MIONS - FRANCE**  
**TELEPHONE +33 (0)4 72 23 20 20 - TELECOPIE +33 (0)4 72 23 20 28**

**LENNOX France, Division Climatisation de LGL FRANCE**  
**Siège Social : LGL FRANCE - 11, rue d'Alsace Lorraine - 69500 BRON - France**