

LGA / LCA / LHA SERIES

The LGA / LCA / LHA 7.5, 8.5, 10 and 12 ton (26.3, 29.8, 35.2, and 42.2 kW) units are configured to order units (CTO) with a wide selection of factory installed options. The LGA088/100 (7.5 and 8.5 ton) gas /electric rooftop units, are available in 125,000 Btuh or 180,000 Btuh (36.6 kW or 52.74 kW) heating inputs and share the same cabinet size with one condenser fan. The LGA-102/ 120/150 (8.5, 10 and 12 ton) gas/electric packaged rooftop units, are available in 130,000 Btuh or 235,000 Btuh (38.09 kW or 68.9kW) heating inputs and share a larger cabinet size with two condenser fans. Gas heat sections are designed with Lennox' aluminized or optional stainless steel tube heat exchangers. The LCA088 through 150 cooling packaged rooftop units are equipped with the same cooling sections as the LGA088 through 150 units. Optional electric heat is factory or field-installed in LCA units.

Electric heat operates in single or multiple stages depending on the kW input size. 7.5 kW through 60kW heat sections are available. All units utilize two compressors.

The LHA088 packaged heat pump units are available in 86,000 Btuh (25.3 kW) heating inputs and 7.5 ton (26.3 kW) cooling capacities. The LHA088 utilizes one compressor, one reversing valve, one accumulator and other parts common to a heat pump. The LHA090 and 120 packaged heat pump units are available in 90,000 Btuh and 119,000 Btuh (26.3 and 34.9 kW) heating outputs and 7.5 ton and 10 ton (26.3 and 35.2 kW) cooling capacities. The LHA090/120 refrigerant systems utilizes two compressors, two reversing valves, two accumulators, and other parts common to a heat pump. Optional auxiliary electric heat is factory or field installed in LHA units. Electric heat operates in single or multiple stages depending on the kW input size. 7.5kW through 45kW heat sections are available for the LHA088/090 and 15kW through 60kW for LHA120.

The LGA, LCA, and LHA units are designed to accept any of several different energy management thermostat control systems with minimum field wiring. Factory or field provided control options connect to the unit with jack plugs. When "plugged in" the controls become an integral part of the unit wiring.

Information contained in this manual is intended for use by qualified service technicians only. All specifications are subject to change. Procedures outlined in this manual are presented as a recommendation only and do not supersede or replace local or state codes.



LGA120 (10 TON) SHOWN

If the unit must be lifted for service, rig unit by attaching four cables to the holes located in the unit base rail (two holes at each corner). Refer to the installation instructions for the proper rigging technique.

⚠ WARNING

Improper installation, adjustment, alteration, service or maintenance can cause property damage, personal injury or loss of life. Installation and service must be performed by a qualified installer or service agency.

⚠ WARNING

Refrigerant can be harmful if it is inhaled. Refrigerant must be used and recovered responsibly.

Failure to follow this warning may result in personal injury or death.

ELECTROSTATIC DISCHARGE (ESD) Precautions and Procedures

⚠ CAUTION

Electrostatic discharge can affect electronic components. Take precautions during unit installation and service to protect the unit's electronic controls. Precautions will help to avoid control exposure to electrostatic discharge by putting the unit, the control and the technician at the same electrostatic potential. Neutralize electrostatic charge by touching hand and all tools on an unpainted unit surface before performing any service procedure.

TABLE OF CONTENTS

<p>Introduction Page 1</p> <p>Specifications Pages 3-7</p> <p>Field Installed Accessories Pages 8-9</p> <p>Electric Heat Accessories Data Pages 10-11</p> <p>Electrical Data Pages 12-14</p> <p>Blower Data Pages 15-18</p> <p>Parts Arrangement Pages 19-21</p> <p>I- UNIT COMPONENTS Pages 22-46</p> <p>Control Box Components Pages 22-24</p> <p>Cooling Components Pages 26-32</p> <p>Blower Compartment Pages 32-33</p> <p>Gas Heat Components Pages 34-38</p> <p>Electric Heat Data Pages 39-43</p> <p>Electric Heat Components Pages 44-46</p> <p>II- PLACEMENT AND INSTALLATION Page 47</p> <p>III- CHARGING Pages 47-49</p> <p>Normal Operating Pressures Pages 47-48</p> <p>Approach Temperature Page 49</p> <p>IV-STARTUP - OPERATION Page 49</p> <p>Preliminary and Seasonal Checks Page 49</p> <p>Cooling Startup Page 49-50</p> <p>Heating Startup Page 50-51</p> <p>Safety or Emergency Shutdown Page 51</p> <p>V- SYSTEMS SERVICE CHECKS Pages 51-54</p> <p>LGA Heating Service Checks Pages 51-54</p> <p>High Altitude Page 52</p> <p>Cooling Service Checks Page 54</p>	<p>VI-MAINTENANCE Page 54</p> <p>Filters Page 54</p> <p>Lubrication Page 54</p> <p>Supply Air Blower Wheel Page 54</p> <p>Evaporator and Condenser Coil Page 54</p> <p>Electrical Page 54</p> <p>VII-ACCESSORIES Pages 55-58</p> <p>LARMF Roof Mounting Frames Page 55</p> <p>Transitions Page 55</p> <p>Supply and Return Diffusers Page 56</p> <p>LAOAD(M) Outdoor Air Dampers Page 56</p> <p>LAREMD Economizers Pages 56-57</p> <p>LAGED(H) Gravity Exhaust Dampers Page 57</p> <p>LAPEF Power Exhaust Fans Page 57</p> <p>Optional Cold Weather Kit Pages 57</p> <p>Control Systems Page 58</p> <p>Smoke Detectors Page 58</p> <p>Blower Proving Switch Page 58</p> <p>Dirty Filter Switch Page 58</p> <p>Indoor Air Quality Sensor Page 58</p> <p>LP / Propane Kit Page 58</p> <p>VIII-WIRING DIAGRAMS / OPERATION SEQUENCE</p> <p>LGA / LCA 088-100 Page 59</p> <p>LGA /LCA 102-120-150 Page 60</p> <p>LGA Gas Heat Page 62</p> <p>LHA088 Page 64</p> <p>LHA090-120 Page 66</p> <p>Thermostat Page 68</p> <p>Economizer Page 69</p> <p>Electric Heat Page 70</p>
---	---

SPECIFICATIONS LCA/LGA

Model No.		LCA/LGA088		LCA/LGA100	
Cooling Ratings	Efficiency type	Standard	High	Standard	
	Gross Cooling Capacity — Btuh (kW)	94,000 (27.5)	90,000 (26.4)	100,000 (29.3)	
	① Net Cooling Capacity — Btuh (kW)	88,000 (25.8)	85,000 (24.9)	94,000 (27.5)	
	Total Unit Power (kW)	9.77	8.33	10.4	
	① EER (Btuh/Watt)	9.0	10.2	9.0	
	⑤ Integrated Part Load Value (Btuh/Watt)	9.2	10.4	9.0	
② Sound Rating Number (db)		86			
Refrigerant Charge Furnished (HCFC-22)	Circuit 1	8 lbs. 0 oz. (3.63 kg)	8 lbs. 8 oz. (3.86 kg)	8 lbs. 8 oz. (3.86 kg)	
	Circuit 2	8 lbs. 0 oz. (3.63 kg)	8 lbs. 8 oz. (3.86 kg)	8 lbs. 8 oz. (3.86 kg)	
Two Stage Heating Capacity (Natural or LPG/Propane Gas (at Sea Level)	Heat Input Type	Standard	High	Standard	High
	Input (low) — Btuh (kW)	83,000 (24.3)	119,000 (34.9)	83,000 (24.3)	119,000 (34.9)
	Output (Low) — Btuh (kW)	66,000 (19.3)	96,000 (27.8)	66,000 (19.3)	96,000 (27.8)
	Input High — Btuh (kW)	125,000 (36.6)	180,000 (52.8)	125,000 (36.6)	180,000 (36.6)
	Output (High) — Btuh (kW)	100,000 (29.3)	144,000 (42.2)	100,000 (29.3)	144,000 (42.2)
A.G.A./C.G.A. Thermal Efficiency		80.0%			
Gas Supply Connections npt — in. - Natural or ③ LPG/Propane		3/4			
Recommended Gas Supply Pressure — wc. in. (kPa)	Natural	7 (1.7)			
	③ LPG/Propane	11 (2.7)			
Evaporator Blower and Drive Selection	Blower wheel nominal dia. x width — in. (mm)		(1) 12 x 12 (305 x 305)		
	2 hp (1.5 kW) ④ Motor & Drives	Nominal motor output — hp (kW)	2 (1.5)		
		Max. usable motor output — hp (kW)	2.30 (1.7)		
		Voltage & phase	208/230v, 460v or 575v-3ph		
		(Drive kit #) RPM range	(1 or 2) 845-1130 (3 or 4) 1015-1300		
	3 hp (2.2 kW) ④ Motor & Drives	Nominal motor horsepower (kW)	3 (2.2)		
		Max. usable motor output — hp (kW)	3.45 (2.6)		
		Voltage & phase	208/230v, 460v or 575v-3ph		
(Drive kit #) RPM range		(1 or 2) 845-1130 (3 or 4) 1015 - 1300			
Evaporator Coil	Net face area — sq. ft. (m ²)		9.72 (0.90)		
	Tube diameter — in. (mm) & No. of rows		3/8 (9.5) — 3		
	Fins per inch (m)		14 (551.2)		
	Drain connection no. & size — in. (mm) fpt		(1) 1 (25.4)		
	Expansion device type		Balanced Port Thermostatic Expansion Valve, removeable power head		
Condenser Coil	Net face area — sq. ft. (m ²)		23.78 (2.21)		
	Tube diameter — in. (mm) & No. of rows		3/8 (9.5) — 2		
	Fins per inch (m)		20 (787.4)		
Condenser Fans	Diameter — in. (mm) & No. of blades		(1) — 24 (610) - 3		
	Total Air volume — cfm (L/s)		5300 (2501)		
	Motor horsepower (W)		1/2 (373)		
	Motor rpm		1075		
	Total Motor watts		550		
Filters (furnished)	Type of filter		Disposable Commercial Grade Pleated		
	No. and size — in. (mm)		(4) 18 x 20 x 2 (457 x 508 x 51)		
Electrical characteristics		208/230v, 460v or 575v — 60 hertz — 3 phase			

① Rated in accordance with ARI Standard 210/240 and certified to ARI; 95°F (35°C) outdoor air temperature and 80°F (27°C) db/67°F (19°C) wb entering evaporator air; minimum external duct static pressure.

② Sound Rating Number rated in accordance with test conditions included in ARI Standard 270.

③ For LPG/Propane units a field conversion kit is required and must be ordered extra.

④ Using total air volume and system static pressure requirements determine from blower performance tables rpm and motor output required. Maximum usable output of motors furnished by Lennox are shown. In Canada, nominal motor output is also maximum usable motor output. If motors of comparable output are used, be sure to keep within the service factor limitations outlined on the motor nameplate.

⑤ Integrated Part Load Value rated at 80°F (27°C) outdoor air temperature.

NOTE — Net capacity includes evaporator blower motor heat deduction. Gross capacity does not include evaporator blower motor heat deduction.

SPECIFICATIONS LCA/LGA

Model No.		LCA/LGA102	LCA/LGA120	
Evaporator Blower and Drive Selection	Blower wheel nominal dia. x width — in. (mm)	(1) 15 x 15 (381 x 381)		
	2 hp (1.5 kW) *Motor & Drives	Nominal motor output — hp (kW)	2 (1.5)	
		Max. usable motor output — hp (kW)	2.30 (1.7)	
		Voltage & phase	208/230v, 460v or 575v-3ph	
		(Drive kit #) RPM range	(1) 680-925 (3) 895-1120	
	3 hp (2.2 kW) *Motor & Drives	Nominal motor horsepower (kW)	3 (2.2)	
		Max. usable motor output — hp (kW)	3.45 (2.6)	
		Voltage & phase	208/230v, 460v or 575v-3ph	
		(Drive kit #) RPM range	(1) 680-925 (2) 680-895 (3&4) 895-1120 (5&6) 1110-1395	
	5 hp (3.7 kW) *Motor & Drives	Nominal motor output — hp (kW)	5 (3.7)	
		Max. usable motor output — hp (kW)	5.75 (4.3)	
		Voltage & phase	208/230v, 460v or 575v-3ph	
(Drive kit #) RPM range		(4) 895-1120 (6) 1110-1395		
Evaporator Coil	Net face area — sq. ft. (m ²)	10.5 (0.98) total		
	Tube diameter — in. (mm) & No. of rows	3/8 (9.5) — 3	3/8 (9.5) — 3 (standard efficiency) or 3/8 (9.5) — 4 (high efficiency)	
	Fins per inch (m)	14 (551)	14 (551)	
	Drain connection no. & size — in. (mm) fpt	(1) 1 (25.4)	(1) 1 (25.4)	
	Expansion device type	Balanced Port Thermostatic Expansion Valve, removeable power head		
Condenser Coil	Net face area — sq. ft. (m ²)	29.3 (2.72) total		
	Tube diameter — in. (mm) & No. of rows	3/8 (9.5) — 1 (standard efficiency) or 3/8 (9.5) — 2 (high efficiency)	3/8 (9.5) — 2	
	Fins per inch (m)	20 (787)	15 (591) standard & 20 (787) high	
Condenser Fans	Diameter — in. (mm) & No. of blades	(2) 24 (610) — 3		
	Total Air volume — cfm (L/s)	8,000 (3775)		
	Motor horsepower (W)	(2) 1/3 (249)		
	Motor rpm	1075		
	Total Motor watts	700		
Filters (furnished)	Type of filter	Disposable, commercial grade, pleated		
	no. and size — in. (mm)	(4) 18 x 24 x 2 (457 x 610 x 51)		
Electrical characteristics		208/230v, 460v or 575v — 60 hertz — 3 phase		

*Using total air volume and system static pressure requirements determine from blower performance tables rpm and motor output required. Maximum usable output of motors furnished by Lennox are shown. In Canada, nominal motor output is also maximum usable motor output. If motors of comparable output are used, be sure to keep within the service factor limitations outlined on the motor nameplate.

Model No.		LCA/LGA102S	LCA/LGA102H	LCA/LGA120S	LCA/LGA120H
Cooling Ratings	Gross Cooling Capacity — Btuh (kW)	106,000 (31.1)	105,000 (30.8)	126,000 (36.9)	125,000 (36.6)
	*Net Cooling Capacity — Btuh (kW)	102,000 (29.9)	101,000 (29.6)	120,000 (35.2)	120,000 (35.2)
	Total Unit Power (kW)	11.3	9.0	13.3	10.9
	*EER (Btuh/Watt)	9.0	11.0	9.0	11.0
	†Integrated Part Load Value (Btuh/Watt)	9.5	12.0	9.5	11.8
●Sound Rating Number (db)		88	88	88	88
Refrigerant Charge Furnished (HCFC-22)	Circuit 1	7 lbs. 4 oz. (3.28 kg)	9 lbs. 4 oz. (4.20 kg)	9 lbs. 8 oz. (4.31 kg)	11 lbs. 8 oz. (5.22 kg)
	Circuit 2	7 lbs. 4 oz. (3.28 kg)	9 lbs. 4 oz. (4.20 kg)	9 lbs. 8 oz. (4.31 kg)	11 lbs. 8 oz. (5.22 kg)

*Rated in accordance with ARI Standard 210/240 and certified to ARI; 95°F (35°C) outdoor air temperature and 80°F (27°C) db/67°F (19°C) wb entering evaporator air; minimum external duct static pressure.

†Integrated Part Load Value rated at 80°F (27°C) outdoor air temperature.

●Sound Rating Number rated in accordance with test conditions included in ARI Standard 270.

NOTE — Net capacity includes evaporator blower motor heat deduction. Gross capacity does not include evaporator blower motor heat deduction.

Model No.		LGA102		LGA120	
Heat Input Type		Standard	High	Standard	High
Two Stage Heating Capacity (Natural or LPG/Propane Gas (at Sea Level))	Input (low) — Btuh (kW)	84,500 (24.8)	152,500 (44.7)	84,500 (24.8)	152,500 (44.7)
	Output (low) — Btuh (kW)	67,500 (19.8)	122,000 (35.8)	67,500 (19.8)	122,000 (35.8)
	Input (High) — Btuh (kW)	130,000 (38.1)	235,000 (68.9)	130,000 (38.1)	235,000 (68.9)
	Output (High) — Btuh (kW)	104,000 (30.5)	188,000 (55.1)	104,000 (30.5)	188,000 (55.1)
	A.G.A./C.G.A. Thermal Efficiency	80.0%	80.0%	80.0%	80.0%
Gas Supply Connections npt — in.	Natural	3/4			
	*LPG/Propane	3/4			
Recommended Gas Supply Pressure — wc. in. (kPa)	Natural	7 (1.7)		7 (1.7)	
	*LPG/Propane	11 (2.7)		11 (2.7)	

*For LPG/Propane units a field conversion kit is required and must be ordered extra.

SPECIFICATIONS LCA/LGA

Model No.		LCA/LGA150	
Evaporator Blower and Drive Selection	Blower wheel nominal dia. x width — in. (mm)	(1) 15 x 15 (381 x 381)	
	2 hp (1.5 kW) *Motor & Drives	Nominal motor output — hp (kW)	2 (1.5)
		Max. usable motor output — hp (kW)	2.30 (1.7)
		Voltage & phase	208/230v, 460v or 575v-3ph
		RPM range (Drive 1 or 3 options)	(1)680-925 (3)895-1120
	3 hp (2.2 kW) *Motor & Drives	Nominal motor output — hp (kW)	3 (2.2)
		Max. usable motor output — hp (kW)	3.45 (2.6)
		Voltage & phase	208/230v, 460v or 575v-3ph
		RPM range (Drive 1 thru 6 options)	(1) 680-925 (2) 680-895 (3&4) 895-1120 (5&6) 1110-1395
	5 hp (3.7 kW) *Motor & Drives	Nominal motor horsepower (kW)	5 (3.7)
		Max. usable motor output — hp (kW)	5.75 (4.3)
		Voltage & phase	208/230v, 460v or 575v-3ph
RPM range (Drive 4 & 6 options)		(4) 895-1120 (6) 1110-1395	
Evaporator Coil	Net face area — sq. ft. (m ²)	10.5 (0.98) total	
	Tube diameter — in. (mm) & No. of rows	3/8 (9.5) — 3	
	Fins per inch (m)	14 (551)	
	Drain connection no. & size — in. (mm) fpt	(1) 1 (25.4)	
	Expansion device type	Balanced Port Thermostatic Expansion Valve, removeable power head	
Condenser Coil	Net face area — sq. ft. (m ²)	29.3 (2.72) total	
	Tube diameter — in. (mm) & No. of rows	3/8 (9.5) — 2	
	Fins per inch (m)	20 (787)	
Condenser Fans	Diameter — in. (mm) & No. of blades	(2) 24 (610) — 3	
	Total Air volume — cfm (L/s)	8000 (3775)	
	Motor horsepower (W)	(2) 1/3 (249)	
	Motor rpm	1075	
	Total Motor watts	700	
Filters (furnished)	Type of filter	Disposable, commercial grade, pleated	
	no. and size — in. (mm)	(4) 18 x 24 x 2 (457 x 610 x 51)	
Electrical characteristics		208/230v, 460v or 575v — 60 hertz — 3 phase	

*Using total air volume and system static pressure requirements determine from blower performance tables rpm and motor output required. Maximum usable output of motors furnished by Lennox are shown. In Canada, nominal motor output is also maximum usable motor output. If motors of comparable output are used, be sure to keep within the service factor limitations outlined on the motor nameplate.

Model No.		LCA/LGA150S
Cooling Ratings	Gross Cooling Capacity — Btuh (kW)	145,000 (42.5)
	*Net Cooling Capacity — Btuh (kW)	138,000 (40.4)
	Total Unit Power (kW)	15.3
	*EER (Btuh/Watt)	9.0
	†Integrated Part Load Value (Btuh/Watt)	9.5
●Sound Rating Number (db)		88
Refrigerant Charge Furnished (HCFC-22)	Circuit 1	12 lbs. 0 oz. (5.44 kg)
	Circuit 2	12 lbs. 0 oz. (5.44 kg)

*Rated in accordance with ARI Standard 340/360 and certified to ARI; 95°F (35°C) outdoor air temperature and 80°F (27°C) db/67°F (19°C) wb entering evaporator air; minimum external duct static pressure.

†Integrated Part Load Value rated at 80°F (27°C) outdoor air temperature.

●Sound Rating Number rated in accordance with test conditions included in ARI Standard 270.

NOTE — Net capacity includes evaporator blower motor heat deduction. Gross capacity does not include evaporator blower motor heat deduction.

Model No.		LGA150	
Heat Input Type		Standard	High
Two Stage Heating Capacity (Natural or LPG/Propane Gas (at Sea Level)	Input (low) — Btuh (kW)	84,500 (24.8)	152,500 (44.7)
	Output (low) — Btuh (kW)	67,500 (19.8)	122,000 (35.8)
	Input (High) — Btuh (kW)	130,000 (38.1)	235,000 (68.9)
	Output (High) — Btuh (kW)	104,000 (30.5)	188,000 (55.1)
	A.G.A./C.G.A. Thermal Efficiency	80.0%	80.0%
Gas Supply Connections npt — in.	Natural	3/4	
	*LPG/Propane	3/4	
Recommended Gas Supply Pressure — wc. in. (kPa)	Natural	7 (1.7)	
	*LPG/Propane	11 (2.7)	

*For LPG/Propane units a field conversion kit is required and must be ordered extra.

SPECIFICATIONS LHA

Model No.		LHA088S	
Cooling Ratings	Efficiency Type	Standard	
	Gross Cooling Capacity — Btuh (kW)	91,000 (26.7)	
	① Net Cooling Capacity — Btuh (kW)	86,000 (25.2)	
	Total Unit Power (kW)	9.6	
	① EER (Btuh/Watt)	9	
High Temperature Heating Ratings	① Total Heating Capacity — Btuh (kW)	86,000 (25.2)	
	Total Unit Power (kW)	8.4	
	① C.O.P.	3.0	
Low Temperature Heating Ratings	① Total Heating Capacity — Btuh (kW)	48,000 (14.1)	
	Total Unit Power (kW)	7.03	
	① C.O.P.	2.0	
② Sound Rating Number (db)		86	
Refrigerant Charge Furnished (HCFC-22)		17 lbs. 0 oz. (7.71 kg)	
Indoor Blower and Drive Selection	Blower wheel nominal dia. x width — in. (mm)		12 x 12 (305 x 305)
	2 hp (1.5 kW) ③ Motor & Drives	Nominal motor output — hp (kW)	2 (1.5)
		Max. usable motor output — hp (kW)	2.30 (1.7)
		Voltage & phase	208/230v, 460v or 575v-3ph
		(Drive Kit #) RPM range	(1 or 2) 845-1130 (3 or 4) 1015-1300
	3 hp (2.2 kW) ③ Motor & Drives	Nominal motor horsepower (kW)	3 (2.2)
		Max. usable motor output — hp (kW)	3.45 (2.6)
		Voltage & phase	208/230v, 460v or 575v-3ph
(Drive Kit #) RPM range		(1 or 2) 845-1130 (3 or 4) 1015-1300	
Indoor Coil	Net face area — sq. ft. (m ²)		9.72 (.90)
	Tube diameter — in. (mm) & No. of rows		3/8 (9.5) — 3
	Fins per inch (m)		14 (551.2)
	Drain connection no. & size — in. (mm) fpt		(1) 1 (25.4)
	Expansion device type		Balanced Port Thermostatic Expansion Valve, removeable power head
Outdoor Coil	Net face area — sq. ft. (m ²)		23.78 (2.21)
	Tube diameter — in. (mm) & No. of rows		3/8 (9.5) — 2
	Fins per inch (m)		20 (787.4)
	Expansion device type		Balanced Port Thermostatic Expansion Valve, removeable power head
Outdoor Fans	Diameter — in. (mm) & No. of blades		24 (610) - 3
	Total Air volume — cfm (L/s)		5300 (2501)
	Motor horsepower (W)		1/2 (373)
	Motor rpm		1075
	Total Motor watts		550
Filters (furnished)	Type of filter		Disposable Commercial Grade Pleated
	No. and size — in. (mm)		(4) 18 x 20 x 2 (457 x 508 x 51)
Electrical characteristics		208/230v, 460v or 575v — 60 hertz — 3 phase	

① Rated in accordance with ARI Standard 210/240 and certified to ARI.

Cooling Ratings— 95°F (35°C) outdoor air temperature and 80°F (27°C) db/67°F (19°C) wb entering indoor coil air.

High Temperature Heating Ratings— 47°F (8°C) db/43°F (6°C) wb outdoor air temperature and 70°F (21°C) entering indoor coil air.

Low Temperature Heating Ratings— 17°F (-8°C) db/15°F (-9°C) wb outdoor air temperature and 70°F (21°C) entering indoor coil air.

② Sound Rating Number rated in accordance with test conditions included in ARI Standard 270.

③ Using total air volume and system static pressure requirements determine from blower performance tables rpm and motor output required. Maximum usable output of motors furnished by Lennox are shown.

In Canada, nominal motor output is also maximum usable motor output. If motors of comparable output are used, be sure to keep within the service factor limitations outlined on the motor nameplate.

NOTE — ARI capacity is net and includes indoor blower motor heat deduction. Gross capacity does not include indoor blower motor heat deduction.

SPECIFICATIONS LHA

Model No.		LHA090H	LHA120H	
Efficiency Type		High	High	
Cooling Ratings	Gross Cooling Capacity — Btuh (kW)	94,000 (27.5)	124,000 (36.3)	
	*Net Cooling Capacity — Btuh (kW)	90,000 (26.4)	118,000 (34.6)	
	Total Unit Power (kW)	7.8	11.5	
	*EER (Btuh/Watt)	11.5	10.3	
	†Integrated Part Load Value (Btuh/Watt)	12.0	11.3	
High Temperature Heating Ratings	*Total Heating Capacity — Btuh (kW)	90,000 (26.4)	119,000 (34.9)	
	Total Unit Power (kW)	8.0	10.7	
	*C.O.P.	3.3	3.3	
Low Temperature Heating Ratings	*Total Heating Capacity — Btuh (kW)	52,000 (15.2)	72,000 (21.1)	
	Total Unit Power (kW)	7.3	10.1	
	*C.O.P.	2.1	2.1	
●Sound Rating Number (db)		88	88	
Refrigerant Charge Furnished (HCFC-22)	Circuit 1	12 lbs. 0 oz. (5.4 kg)	12 lbs. 8 oz. (5.7 kg)	
	Circuit 2	10 lbs. 10 oz. (4.8 kg)	12 lbs. 8 oz. (5.7 kg)	
Evaporator Blower and Drive Selection	Blower wheel nominal dia. x width — in. (mm)		(1) 15 x 15 (381 x 381)	
	2 hp (1.5 kW) *Motor & Drives	Nominal motor output — hp (kW)	2 (1.5)	
		Max. usable motor output — hp (kW)	2.30 (1.7)	
		Voltage & phase	208/230v, 460v or 575v-3ph	
		RPM range (Drive 1 or 3 options)	(1) 680-925 (3) 895-1120	
	3 hp (2.2 kW) *Motor & Drives	Nominal motor horsepower (kW)	3 (2.2)	
		Max. usable motor output — hp (kW)	3.45 (2.6)	
		Voltage & phase	208/230v, 460v or 575v-3ph	
		RPM range (Drive 1 thru 6 options)	(1) 680-925 (2) 680-895 (3) 850-1130 (4) 895-1120, (5) 1105-1410 (6) 1110-1395	
	5 hp (3.7 kW) *Motor & Drives	Nominal motor output — hp (kW)	5 (3.7)	
		Max. usable motor output — hp (kW)	5.75 (4.3)	
		Voltage & phase	208/230v, 460v or 575v-3ph	
RPM range (Drive 4 & 6 options)		(4) 895-1120 (6) 1110-1395		
Indoor Coil	Net face area — sq. ft. (m ²)		10.5 (0.98) total	
	Tube diameter — in. (mm) & No. of rows		3/8 (9.5) — 3 3/8 (9.5) — 4	
	Fins per inch (m)		14 (551)	
	Drain connection no. & size — in. (mm) fpt		(1) 1 (25.4)	
	Expansion device type		Balanced Port Thermostatic Expansion Valve, removeable power head	
Outdoor Coil	Net face area — sq. ft. (m ²)		28.6 (2.66) total	
	Tube diameter — in. (mm) & No. of rows		3/8 (9.5) — 2 3/8 (9.5) — 2	
	Fins per inch (m)		20 (787)	
	Expansion device type		Balanced Port Thermostatic Expansion Valve, removeable power head	
Outdoor Fans	Diameter — in. (mm) & No. of blades		(2) 24 (610) — 3	
	Total Air volume — cfm (L/s)		8000 (3775)	
	Motor horsepower (W)		(2) 1/3 (249)	
	Motor rpm		1075	
	Total Motor watts		700	
Filters (furnished)	Type of filter		Disposable, commercial grade, pleated	
	no. and size — in. (mm)		(4) 18 x 24 x 2 (457 x 610 x 51)	
Electrical characteristics		208/230v, 460v or 575v — 60 hertz — 3 phase		

*Rated in accordance with ARI Standard 210/240 and certified to ARI.

Cooling Ratings— 95°F (35°C) outdoor air temperature and 80°F (27°C) db/67°F (19°C) wb entering indoor coil air.

High Temperature Heating Ratings— 47°F (8°C) db/43°F (6°C) wb outdoor air temperature and 70°F (21°C) entering indoor coil air.

Low Temperature Heating Ratings— 17°F (-8°C) db/15°F (-9°C) wb outdoor air temperature and 70°F (21°C) entering indoor coil air.

†Integrated Part Load Value tested at 80°F (27°C) outdoor air temperature.

●Sound Rating Number rated in accordance with test conditions included in ARI Standard 270.

NOTE — ARI capacity is net and includes indoor blower motor heat deduction. Gross capacity does not include indoor blower motor heat deduction.

**Using total air volume and system static pressure requirements determine from blower performance tables rpm and motor output required. Maximum usable output of motors furnished by Lennox are shown. In Canada, nominal motor output is also maximum usable motor output. If motors of comparable output are used, be sure to keep within the service factor limitations outlined on the motor nameplate.

OPTIONAL FIELD INSTALLED ACCESSORIES

Item	LCA/LGA088	LCA/LGA100	LHA088
Blower Proving Switch — Monitors blower operation, shuts down unit if blower fails		18L89	
Condensate Drain Trap - field installed only, may be factory enclosed to ship with unit	PVC	37K70	
	Copper	48K14	
Control Systems — See pages 5-10 for complete listing.		See pages 5-10	
Dirty Filter Switch — Senses static pressure increase indicating a dirty filter condition		30K48	
Down-Flow Gravity Exhaust Dampers — Aluminum blade dampers prevent blow back and outdoor air infiltration during off cycle, bird screen furnished - Net Weight. NOTE - See below for damper hood.		LAGED08/10 - 8 lbs. (4 kg)	
Down-Flow Gravity Exhaust Dampers Hood (Field Installed Only) - Net Weight		24L15 - 25 lbs. (11 kg)	
Economizer — Opposing gear driven recirculated air and outdoor air dampers, plug-in connections to unit, nylon bearings, neoprene seals, 24 volt fully modulating spring return motor, adjustable minimum damper position, damper assembly slides in unit, outdoor air hood must be ordered separately (see below), optional down-flow gravity exhaust dampers available (see below), choice of economizer controls (see below) - Net Weight		LAREMD08/10 - 43 lbs. (20 kg)	
Economizer Control Choice — Sensible Control — Furnished on IMC board in unit, uses outdoor air sensor furnished with unit to measure outdoor air temperature and control damper position (Furnished) Global Control — Furnished on IMC board in unit, used with Direct Digital Control (DDC) systems, uses global air sensor to control damper position, determines when to use outdoor air for cooling or set damper at minimum position (Furnished) Outdoor Enthalpy Control — Adjustable enthalpy sensor, senses outdoor air enthalpy for economizer control, 0 to 100% outdoor air Differential Enthalpy Control — Two solid-state enthalpy sensors allow selection between outdoor air and return air (whichever has lowest enthalpy)		(16K96) Outdoor (16K97) Differential	
Electric Heat — Factory or field installed, helix wound nichrome elements, time delay for element staging, individual element limit controls, wiring harness, may be two-stage controlled, requires Fuse Block and Terminal Block (LHA/LCA Models)		See Electric Heat Data Tables	
Electric Heat Fuse Block — Required with Electric Heat. Mounting screws furnished (LCA/LHA Models)		See Optional Electric Heat Accessories Table (LCA/LHA Models).	
Electric Heat LTB2 Terminal Block — Required with electric heat			
Outdoor Air Damper Section — Linked mechanical dampers, 0 to 25% (fixed) outdoor air adjustable, installs in unit for down-flow applications, outdoor air hood must be ordered separately (see below) - Net Weight	Automatic — fully modulating spring return damper motor with plug in connection	LAOADM08/10 - 28 lbs. (13 kg)	
	Manual	LAOAD10/15 - 26 lbs. (12 kg)	
Outdoor Air Hood — Required with LAREMD08/10 Economizer, LAOAD10/15 and LAOADM08/10 Outdoor Air Damper Sections, two cleanable aluminum mesh fresh air filters furnished - Net Weight		LAOAH08/10 - 11 lbs. (5 kg) Filter size: 16 x 20 x 1 in. (406 x 508 x 25 mm)	
Power Exhaust Fan — Installs in unit for down-flow applications only with economizer option, provides exhaust air pressure relief, interlocked to run when return air dampers are closed and supply air blower is operating, fan runs when outdoor air dampers are 50% open (adjustable), motor is overload protected, requires optional down-flow gravity exhaust dampers (see above)	Model Number - Net Weight	LAPEF08/10 - 28 lbs. (13 kg)	
	Diameter - in. (mm) Number of Blades	20 (508) - 5	
	Total air volume - cfm (L/s)	4200 (1980) @ 0 in. .wg. (0 Pa)	
	Motor Horsepower (W)	1/3 (249)	
	Total Watts Input	300	
Smoke Detector — Photoelectric type, installed in supply air section or return air section or both sections		70K87 - Supply 70K86 - Return	
Aspiration box — for duct mounting of Indoor Air Quality Sensor		47N18	
Coil Guards — Galvanized steel wire guards to protect outdoor coil. Not used with Hail Guards		24L55	
Dehumidistat - Monitors humidity levels, reports to the IMC board which allows the heating and cooling to run simultaneously as needed		65F86	
Diffusers - Aluminum grilles, large center grille, insulated diffuser box with flanges, hanging rings furnished, interior transition (even air flow), internally sealed (prevents recirculation), adapts to T-bar ceiling grids or plaster ceilings - Net Weight	Step-Down - double deflection louvers	RTD11-95 - 88 lbs. (40 kg)	
	Flush - fixed blade louvers	FD11-95 - 75 lbs. (34 kg)	
Downflow Roof Mounting Frame — Nailer strip furnished, mates to unit, U.S. National Roofing Contractors Approved, shipped knocked down - Net Weight	14 inch (356 mm) height	LARMF08/10-14 - 118 lbs. (54 kg)	
	24 inch (610 mm) height	LARMF08/10-24 - 162 lbs. (74 kg)	
Hail Guards — Constructed of heavy gauge steel, painted to match cabinet, helps protect outdoor coils from hail damage. Not used with Coil Guards		24L54	
Horizontal Conversion Kit — Two piece duct cover in kit blocks off unit down-flow supply air opening, horizontal return air opening panel (on unit) is moved to block off down-flow return air opening for horizontal applications		17L25	
Horizontal Gravity Exhaust Dampers — Aluminum blade dampers prevent blow back and outdoor air infiltration during off cycle, field installed in return air duct, bird screen and hood furnished - Net Weight		LAGEDH03/15 - 30 lbs. (14 kg)	
Indoor Air Quality (CO₂) Sensor — Monitors CO ₂ levels, reports to Integrated Modular Control (IMC) board which adjusts economizer dampers as needed		93J69	
IMC Software and PC Interface Kit		86K84	
IMC Software and Manual Only		32K22	
PC Interface Kit Only		28K56	
LPG/Propane Kits (LGA Models Only)		98L34	----
Transitions (Supply and Return) — Used with diffusers, installs in roof mounting frame, galvanized steel construction, flanges furnished for duct connection, fully insulated - Net Weight		LASRT08/10 - 30 lbs. (14 kg)	

① Required if mixed air temperature is between 30 and 45 °F (-1 and 7 °C).

② Not available for LCA models with field installed electric heat, LCA 208/230v models with 30 kW or 45kW electric heat, LHA 208/230v models with 15 kW, 30 kW or 45 kW electric heat or for LHA 460v models with 45 kW electric heat.

OPTIONAL FIELD INSTALLED ACCESSORIES

Unit Model No.		LCA/LGA102/120/150 & LHA090/120	
LPG/Propane Conversion Kit (LGA standard heat models only)		23M91	
LPG/Propane Conversion Kit (LGA high heat models only)		98L35	
❖ Cold Weather Kit (LGA models only)		65C03	
Down-Flow Roof Mounting Frame (Net Weight)	14 inch (356 mm) height	LARMF10/15-14 - 126 lbs. (57 kg)	
	24 inch (610 mm) height	LARMF10/15-24 - 174 lbs. (79 kg)	
Economizer (Outdoor Air Hood Required - Order Separately)	Model No. — (Net Weight)	LAREMD10/15 - 47 lbs. (21 kg)	
Outdoor Air Hood — (Net Weight)		LAOAH10/15 - 11 lbs. (5 kg)	
Outdoor Enthalpy Control		16K96	
Differential Enthalpy Control		16K97	
Gravity Exhaust Dampers (Required With Economizer) (Net Weight)	Down-Flow	LAGED10/15 - 8 lbs. (4 kg)	
	*Horizontal	LAGEDH10/15 - 8 lbs. (4 kg)	
Horizontal Conversion Kit		56K53	
Power Exhaust Fan (Down-Flow Only) (Available With Economizer Only, Down-flow Gravity Exhaust Dampers Required)	Model No. (Net Weight)	LAPEF10/15 - 28 lbs. (13 kg)	
	Diameter — in. (mm) & No. of Blades	(1) 20 (508) - 5	
	Total air volume — cfm (L/s)	4200 (1980) @ 0 in. w.g. (0 Pa)	
	Motor Horsepower (W)	(1) 1/3 (249)	
	Total Watts input	300	
Ceiling Supply and Return Air Diffusers (Net Weight)	Step-Down	RTD11-135 (090, 102 & 120 models) 205 lbs. (93 kg)	RTD11-185 (150 models) 392 lbs. (178 kg)
	Flush	FD11-135 (090, 102 & 120 models) 174 lbs. (79 kg)	FD11-185 (150 models) 289 lbs. (131 kg)
	Transition	LASRT10/12 (090, 102 & 120 models) 32 lbs. (15 kg)	LASRT15 (150 models) 36 lbs. (16 kg)
Outdoor Air Damper (Manual Operation) — (Net Weight) (Outdoor Air Hood Required - Order Separately)		LAOAD10/15 - 26 lbs. (12 kg)	
Outdoor Air Damper (Automatic Operation) — (Net Weight) (Outdoor Air Hood Required - Order Separately)		LAOADM10/15 - 31 lbs. (14 kg)	
Outdoor Air Hood — (Net Weight)		LAOAH10/15 - 11 lbs. (5 kg)	
Indoor Air Quality (CO ₂) Sensor		18K51	

*Field installs in return air duct. Two dampers furnished per order no.

OPTIONAL ELECTRIC HEAT ACCESSORIES LCA/LHA

UNIT FUSE BLOCKS WITH ELECTRIC HEAT						
Unit Model No.		LCA088S	LCA088H	LCA100S	LHA088S	
Electric Heat	Model No.	EHA (see Electric Heat Data tables for additional information)				
	kW Input Range	7.5 - 15 - 22.5 -30 - 45				
Unit Fuse Block (3 phase)	With Power Exhaust Fans	208/230v - 2 hp (1.5 kW)	56K93		56K95	
		460v - 2 hp (1.5 kW)	56K52		25K09	
		575v - 2 hp (1.5 kW)	56K51		56K52	
		208/230v - 3 hp (2.2 kW)	56K93		56K96	
		460v - 3 hp (2.2 kW)	25K08	56K52		25K10
		575v - 3 hp (2.2 kW)	56K52	56K51		25K08
	Without Power Exhaust Fans	208/230v - 2 hp (1.5 kW)	56K93		56K95	
		460v - 2 hp (1.5 kW)	56K52		25K09	
		575v - 2 hp (1.5 kW)	56K51		56K52	
		208/230v - 3 hp (2.2 kW)	56K93		56K95	
		460v - 3 hp (2.2 kW)	56K52		25K09	
		575v - 3 hp (2.2 kW)	56K52	56K51		56K52

LTB2 ELECTRIC HEAT TERMINAL BLOCK

LTB2-175 (30K75) 175 amps, **LTB2-335 (30K76)** 335 amps

(Required For Units Without Disconnect/Circuit Breaker But With Single Point Power Source)

LTB2 Terminal Block (3 phase)	7.5 kW *208/230v-3ph	2 hp (1.5 kW)	30K75		
		3 hp (2.2 kW)			
	15 kW *208/230v-3ph	2 hp (1.5 kW)	30K75		
		3 hp (2.2 kW)			
	22.5 kW *208/230v-3ph	2 hp (1.5 kW)	30K75		
		3 hp (2.2 kW)			
	30 kW *208/230v-3ph	2 hp (1.5 kW)	30K75		
		3 hp (2.2 kW)			
	45 kW *208/230v-3ph	2 hp (1.5 kW)	30K75		30K76
		3 hp (2.2 kW)			

NOTE — Terminal Block is factory installed in units with factory installed electric heat without disconnect/circuit breaker but with single point power source.

***NOTE — ALL 460V AND 575V UNIT VOLTAGES USE LTB2-175 (30K75) TERMINAL BLOCK.**

OPTIONAL ELECTRIC HEAT ACCESSORIES LCA / LHA

UNIT FUSE BLOCKS WITH ELECTRIC HEAT

Unit Model No.		LCA102S	LCA102H	LCA120S	LCA120H	LCA150S	LHA090H	LHA120H	
Electric Heat	Model No.	EHA (see Electric Heat Data tables for additional information)							
	kW Input Range	7.5-15-30-45-60							
Unit Fuse Block (3 phase)	Without Power Exhaust Fans	208/230v - 2 hp (1.5 kW)	56K93	56K93	56K94	56K94	56K96	56K93	56K94
		460v - 2 hp (1.5 kW)	25K08	25K08	25K08	25K09	25K08	56K52	25K09
		575v - 2 hp (1.5 kW)	56K51	56K51	56K51	56K52	56K52	56K51	56K52
		208/230v - 3 hp (2.2 kW)	56K94	56K93	56K95	56K95	56K96	56K93	56K95
		460v - 3 hp (2.2 kW)	25K08	25K08	25K09	25K09	25K08	56K52	25K09
		575v - 3 hp (2.2 kW)	56K52	56K52	56K52	56K52	56K52	56K51	56K52
		208/230v - 5 hp (3.7 kW)	56K95	56K94	56K95	56K95	56K96	56K94	56K95
		460v - 5 hp (3.7 kW)	25K09	25K08	25K09	25K09	25K09	25K08	25K09
	575v - 5 hp (3.7 kW)	56K52	56K52	56K52	25K08	56K52	56K52	25K08	
	With Power Exhaust Fans	208/230v - 2 hp (1.5 kW)	56K94	56K93	56K94	56K95	56K96	56K93	56K95
		460v - 2 hp (1.5 kW)	25K08	25K08	25K09	25K09	25K08	56K52	25K09
		575v - 2 hp (1.5 kW)	56K52	56K51	56K52	56K52	56K52	56K51	56K52
		208/230v - 3 hp (2.2 kW)	56K94	56K94	56K95	56K95	56K96	56K93	56K95
		460v - 3 hp (2.2 kW)	25K08	25K08	25K09	25K09	25K09	25K08	25K09
		575v - 3 hp (2.2 kW)	56K52	56K52	56K52	25K08	56K52	56K51	25K08
		208/230v - 5 hp (3.7 kW)	56K95	56K95	56K95	56K96	25K15	56K94	56K96
460v - 5 hp (3.7 kW)		25K09	25K09	25K09	25K10	25K09	25K08	25K10	
575v - 5 hp (3.7 kW)	56K52	56K52	56K52	25K08	25K08	56K52	25K08		

LTB2 ELECTRIC HEAT TERMINAL BLOCK

LTB2-175 (30K75) 175 amps, LTB2-335 (30K76) 335 amps

(Required For Units Without Disconnect/Circuit Breaker But With Single Point Power Source)

Unit Model No.		LCA102S	LCA102H	LCA120S	LCA120H	LCA150S	LHA090H	LHA120H	
LTB2 Terminal Block (3 phase)	7.5 kW *208/230v-3ph	2 hp (1.5 kW)	30K75	30K75	----	----	----	30K75	----
		3 hp (2.2 kW)							
		5 hp (3.7 kW)							
	15 kW *208/230v-3ph	2 hp (1.5 kW)	30K75	30K75	30K75	30K75	30K75	30K75	30K75
		3 hp (2.2 kW)							
		5 hp (3.7 kW)							
	30 kW *208/230v-3ph	2 hp (1.5 kW)	30K75	30K75	30K75	30K75	30K75	30K75	30K75
		3 hp (2.2 kW)							
		5 hp (3.7 kW)							
	45 kW *208/230v-3ph	2 hp (1.5 kW)	30K75	30K75	30K75	30K75	30K75	30K76	30K76
		3 hp (2.2 kW)							
		5 hp (3.7 kW)							
60 kW *208/230v-3ph	2 hp (1.5 kW)	----	----	30K75	30K75	30K75	----	30K76	
	3 hp (2.2 kW)								
	5 hp (3.7 kW)								

NOTE — Terminal Block is factory installed in units with factory installed electric heat without disconnect/circuit breaker but with single point power source.

***NOTE — ALL 460V AND 575V UNIT VOLTAGES USE LTB2-175 (30K75) TERMINAL BLOCK.**

ELECTRICAL DATA

Model No.		LCA/LGA088												
Line voltage data — 60 Hz — 3 phase		208/230v				460v				575v				
Efficiency type		Standard (S)		High (H)		Standard (S)		High (H)		Standard (S)		High (H)		
Compressors (2)	Rated load amps each (total)	12.2 (24.4)		12.4 (24.9)		7.1 (14.1)		6.4 (12.8)		5.8 (11.5)		5.0 (10)		
	Locked rotor amps each (total)	90 (180)		88 (176)		46 (92)		44 (88)		37 (74)		34 (68)		
Outdoor Fan Motor	Full load amps	3.0		3.0		1.5		1.5		1.2		1.2		
	Locked rotor amps	6.0		6.0		3.0		3.0		2.9		2.9		
Indoor Blower Motor	Motor Output	hp	2	3	2	3	2	3	2	3	2	3	2	3
		kW	1.5	2.2	1.5	2.2	1.5	2.2	1.5	2.2	1.5	2.2	1.5	2.2
	Full load amps	7.5	10.6	7.5	10.6	3.4	4.8	3.4	4.8	2.7	2.9	2.7	3.9	
	Locked rotor amps	46.9	66	46.9	66	20.4	26.8	20.4	26.8	16.2	23.4	16.2	23.4	
Rec. max. fuse size (amps)	With Exhaust Fan	50	50	50	50	25	30	25	25	20	25	20	20	
	Less Exhaust Fan	50	50	50	50	25	30	25	25	20	25	20	20	
*Minimum Circuit Ampacity	With Exhaust Fan	41	44	41	44	23	24	21	23	18	20	17	18	
	Less Exhaust Fan	38	42	39	42	21	23	20	21	17	19	16	17	
Optional Power Exhaust Fan	(No.) Horsepower (W)	(1) 1/3 (249)												
	Full load amps	2.4		2.4		1.3		1.3		1.0		1.0		
	Locked rotor amps	4.7		4.7		2.4		2.4		1.9		1.9		
Service Outlet (2) 115 volt GFCI (amp rating)		15												

*Refer to National or Canadian Electrical Code manual to determine wire, fuse and disconnect size requirements.
 NOTE — Extremes of operating range are plus and minus 10 % of line voltage.
 NOTE — Where current does not exceed 100 amps, HACR type circuit breaker may be used in place of fuse (U.S. only).

ELECTRICAL DATA

Model No.		LCA/LGA100S						LHA088S						
Line voltage data — 60 Hz — 3 phase		208/230v		460v		575v		208/230v		460v		575v		
Efficiency Type		Standard (S)												
Compressors (2 - LCA/LGA) (1 - LHA)	Rated load amps each (total)	13.5 (26.9)		6.7 (13.3)		5.0 (10)		28.8		14.7		10.8		
	Locked rotor amps each (total)	115 (230)		47.5 (95)		37.5 (75)		195		95		80		
Outdoor Fan Motor	Full load amps	3.0		1.5		1.2		3.0		1.5		1.2		
	Locked rotor amps	6.0		3.0		2.9		6.0		3.0		2.9		
Indoor Blower Motor	Motor Output	hp	2	3	2	3	2	3	2	3	2	3	2	3
		kW	1.5	2.2	1.5	2.2	1.5	2.2	1.5	2.2	1.5	2.2	1.5	2.2
	Full load amps	7.5	10.6	3.4	4.8	2.7	3.9	7.5	10.6	3.4	4.8	2.7	3.9	
	Locked rotor amps	46.9	66	20.4	26.8	16.2	23.4	46.9	66	20.4	26.8	16.2	23.4	
Rec. max. fuse size (amps)	With Exhaust Fan	50	50	25	25	20	20	70	70	35	35	25	25	
	Less Exhaust Fan	50	50	25	25	20	20	70	70	35	35	25	25	
*Minimum Circuit Ampacity	With Exhaust Fan	44	47	22	23	17	18	49	53	25	27	19	20	
	Less Exhaust Fan	41	44	20	22	16	17	47	50	24	25	18	19	
Optional Power Exhaust Fan	(No.) Horsepower (W)	(1) 1/3 (249)												
	Full load amps	2.4		1.3		1.0		2.4		1.3		1.0		
	Locked rotor amps	4.7		2.4		1.9		4.7		2.4		1.9		
Service Outlet (2) 115 volt GFCI (amp rating)		15												

*Refer to National or Canadian Electrical Code manual to determine wire, fuse and disconnect size requirements.
 NOTE — Extremes of operating range are plus and minus 10 % of line voltage.
 NOTE — Where current does not exceed 100 amps, HACR type circuit breaker may be used in place of fuse (U.S. only).

ELECTRICAL DATA

Model No.			LCA/LGA102																	
Line voltage data — 60 Hz — 3 phase			208/230v						460v						575v					
Unit Efficiency			Standard (S)			High (H)			Standard (S)			High (H)			Standard (S)			High (H)		
Compressors (2)	Rated load amps each (total)		14.1 (28.2)			13.5 (27.0)			7.7 (15.4)			7.4 (14.8)			6.0 (12.0)			5.8 (11.6)		
	Locked rotor amps each (total)		105 (210)			120 (240)			53 (106)			50 (100)			42 (84)			40 (80)		
Condenser Fan Motors (2)	Full load amps (total)		2.4 (4.8)			2.4 (4.8)			1.3 (2.6)			1.3 (2.6)			1.0 (2.0)			1.0 (2.0)		
	Locked rotor amps (total)		4.7 (9.4)			4.7 (9.4)			2.4 (4.8)			2.4 (4.8)			1.9 (3.8)			1.9 (3.8)		
Evaporator Blower Motor	Motor Output	hp	2	3	5	2	3	5	2	3	5	2	3	5	2	3	5	2	3	5
		kW	1.5	2.2	3.7	1.5	2.2	3.7	1.5	2.2	3.7	1.5	2.2	3.7	1.5	2.2	3.7	1.5	2.2	3.7
	Full load amps		7.5	10.6	16.7	7.5	10.6	16.7	3.4	4.8	7.6	3.4	4.8	7.6	2.7	3.9	6.1	2.7	3.9	6.1
	Locked rotor amps		46.9	66	105	46.9	66	105	20.4	26.8	45.6	20.4	26.8	45.6	16.2	23.4	36.6	16.2	23.4	36.6
Rec. max. fuse size (amps)	With Exhaust Fan		60	60	70	50	60	70	30	30	35	30	30	35	25	25	25	20	25	25
	Less Exhaust Fan		50	60	70	50	50	60	30	30	35	30	30	30	20	25	25	20	25	25
*Minimum Circuit Ampacity	With Exhaust Fan		46	50	56	45	48	55	25	26	29	24	25	28	19	20	23	19	20	22
	Less Exhaust Fan		44	47	54	43	46	53	23	25	28	23	24	27	18	19	22	18	19	21
Optional Power Exhaust Fan	(No.) Horsepower (W)		(1) 1/3 (249)																	
	Full load amps		2.4			2.4			1.3			1.3			1.0			1.0		
	Locked rotor amps		4.7			4.7			2.4			2.4			1.9			1.9		
Service Outlet (2) 115 volt GFCI (amp rating)			15			15			15			15			15			15		

*Refer to National or Canadian Electrical Code manual to determine wire, fuse and disconnect size requirements.
 NOTE — Extremes of operating range are plus and minus 10 % of line voltage.
 NOTE — Where current does not exceed 100 amps, HACR type circuit breaker may be used in place of fuse (U.S. only).

ELECTRICAL DATA

Model No.			LCA/LGA120																	
Line voltage data — 60 Hz — 3 phase			208/230v						460v						575v					
Unit Efficiency			Standard (S)			High (H)			Standard (S)			High (H)			Standard (S)			High (H)		
Compressors (2)	Rated load amps each (total)		16.7 (33.4)			17.3 (34.6)			8.6 (17.2)			9.0 (18.0)			6.0 (12.0)			7.1 (14.2)		
	Locked rotor amps each (total)		110 (220)			123 (246)			55 (110)			62 (124)			44 (88)			50 (100)		
Condenser Fan Motors (2)	Full load amps (total)		2.4 (4.8)			2.4 (4.8)			1.3 (2.6)			1.3 (2.6)			1.0 (2.0)			1.0 (2.0)		
	Locked rotor amps (total)		4.7 (9.4)			4.7 (9.4)			2.4 (4.8)			2.4 (4.8)			1.9 (3.8)			1.9 (3.8)		
Evaporator Blower Motor	Motor Output	hp	2	3	5	2	3	5	2	3	5	2	3	5	2	3	5	2	3	5
		kW	1.5	2.2	3.7	1.5	2.2	3.7	1.5	2.2	3.7	1.5	2.2	3.7	1.5	2.2	3.7	1.5	2.2	3.7
	Full load amps		7.5	10.6	16.7	7.5	10.6	16.7	3.4	4.8	7.6	3.4	4.8	7.6	2.7	3.9	6.1	2.7	3.9	6.1
	Locked rotor amps		46.9	66	105	46.9	66	105	20.4	26.8	45.6	20.4	26.8	45.6	16.2	23.4	36.6	16.2	23.4	36.6
Rec. max. fuse size (amps)	With Exhaust Fan		60	70	70	70	70	80	35	35	35	35	35	40	25	25	25	25	30	30
	Less Exhaust Fan		60	70	70	60	70	70	30	35	35	35	35	35	20	25	25	25	25	30
*Minimum Circuit Ampacity	With Exhaust Fan		52	55	61	54	57	63	27	28	31	27	29	32	19	20	23	22	23	25
	Less Exhaust Fan		50	53	59	51	54	60	25	27	30	26	28	30	18	19	22	21	22	24
Optional Power Exhaust Fan	(No.) Horsepower (W)		(1) 1/3 (249)																	
	Full load amps		2.4			2.4			1.3			1.3			1.0			1.0		
	Locked rotor amps		4.7			4.7			2.4			2.4			1.9			1.9		
Service Outlet (2) 115 volt GFCI (amp rating)			15			15			15			15			15			15		

*Refer to National or Canadian Electrical Code manual to determine wire, fuse and disconnect size requirements.
 NOTE — Extremes of operating range are plus and minus 10 % of line voltage.
 NOTE — Where current does not exceed 100 amps, HACR type circuit breaker may be used in place of fuse (U.S. only).

ELECTRICAL DATA

Model No.			LCA/LGA150								
Line voltage data — 60 Hz — 3 phase			208/230v			460v			575v		
Unit Efficiency			Standard (S)			Standard (S)			Standard (S)		
Compressors (2)	Rated load amps each (total)		18.6 (37.2)			9.0 (18.0)			7.4 (14.8)		
	Locked rotor amps each (total)		156 (312)			70 (140)			54 (108)		
Condenser Fan Motors (2)	Full load amps (total)		2.4 (4.8)			1.3 (2.6)			1.0 (2.0)		
	Locked rotor amps (total)		3.7 (9.4)			2.4 (4.8)			1.9 (3.8)		
Evaporator Blower Motor	Motor Output	hp	2	3	5	2	3	5	2	3	5
		kW	1.5	2.2	3.7	1.5	2.2	3.7	1.5	2.2	3.7
	Full load amps		7.5	10.6	16.7	3.4	4.8	7.6	2.7	3.9	6.1
	Locked rotor amps		46.9	66	105	20.4	26.8	45.6	16.2	23.4	36.6
Rec. max. fuse size (amps)	With Exhaust Fan		70	70	80	35	35	40	30	30	30
	Less Exhaust Fan		70	70	80	35	30	40	25	30	30
*Minimum Circuit Ampacity	With Exhaust Fan		57	60	66	28	27	32	23	24	26
	Less Exhaust Fan		55	58	64	27	28	31	22	23	25
Optional Power Exhaust Fan	(No.) Horsepower (W)		(1) 1/3 (249)								
	Full load amps		2.4			1.3			1.0		
	Locked rotor amps		4.7			2.4			1.9		
Service Outlet (2) 115 volt GFCI (amp rating)			15			15			15		

*Refer to National or Canadian Electrical Code manual to determine wire, fuse and disconnect size requirements.
 NOTE — Extremes of operating range are plus and minus 10 % of line voltage.
 NOTE — Where current does not exceed 100 amps, HACR type circuit breaker may be used in place of fuse (U.S. only).

ELECTRICAL DATA

Model No.			LHA090H									LHA120H								
Line voltage data — 60 Hz — 3 phase			208/230v			460v			575v			208/230v			460v			575v		
Unit Efficiency			High (H)			High (H)			High (H)			High (H)			High (H)			High (H)		
Compressors (2)	Rated load amps each (total)		12.4 (24.8)			6.4 (12.8)			4.8 (9.6)			17.3 (34.6)			9.0 (18.0)			7.1 (14.2)		
	Locked rotor amps each (total)		88 (176)			44 (88)			34 (68)			123 (246)			62 (124)			50 (100)		
Outdoor Fan Motors (2)	Full load amps (total)		2.4 (4.8)			1.3 (2.6)			1.0 (2.0)			2.4 (4.8)			1.3 (2.6)			1.0 (2.0)		
	Locked rotor amps (total)		4.7 (9.4)			2.4 (4.8)			1.9 (3.8)			4.7 (9.4)			2.4 (4.8)			1.9 (3.8)		
Indoor Blower Motor	Motor Output	hp	2	3	5	2	3	5	2	3	5	2	3	5	2	3	5	2	3	5
		kW	1.5	2.2	3.7	1.5	2.2	3.7	1.5	2.2	3.7	1.5	2.2	3.7	1.5	2.2	3.7	1.5	2.2	3.7
	Full load amps		7.5	10.6	16.7	3.4	4.8	7.6	2.7	3.9	6.1	7.5	10.6	16.7	3.4	4.8	7.6	2.7	3.9	6.1
	Locked rotor amps		46.9	66	105	20.4	26.8	45.6	16.2	23.4	36.6	46.9	66	105	20.4	26.8	45.6	16.2	23.4	36.6
Rec. max. fuse size (amps)	With Exhaust Fan		50	50	60	25	30	30	20	20	25	70	70	80	35	35	40	25	30	30
	Less Exhaust Fan		50	50	60	25	25	30	20	20	25	60	70	70	35	35	35	25	25	30
*Minimum Circuit Ampacity	With Exhaust Fan		43	46	53	22	23	26	17	18	20	54	57	63	27	29	32	22	23	25
	Less Exhaust Fan		40	43	50	20	22	25	16	17	19	51	54	60	26	28	30	21	22	24
Optional Power Exhaust Fan	(No.) Horsepower (W)		(1) 1/3 (249)																	
	Full load amps		2.4			1.3			1.0			2.4			1.3			1.0		
	Locked rotor amps		4.7			2.4			1.9			4.7			2.4			1.9		
Service Outlet (2) 115 volt GFCI (amp rating)			15			15			15			15			15			15		

*Refer to National or Canadian Electrical Code manual to determine wire, fuse and disconnect size requirements.
 NOTE — Extremes of operating range are plus and minus 10 % of line voltage.
 NOTE — Where current does not exceed 100 amps, HACR type circuit breaker may be used in place of fuse (U.S. only).

BLOWER DATA 088 / 100

**BLOWER TABLE INCLUDES RESISTANCE FOR LCA088 BASE UNIT ONLY WITH DRY INDOOR COIL AND AIR FILTERS IN PLACE.
FOR ALL UNITS ADD:**

- 1 - Wet indoor coil air resistance of selected unit.
- 2 - Any factory installed options air resistance (heat section, economizer, etc.)
- 3 - Any field installed accessories air resistance (duct resistance, diffuser, etc.)

Then determine from blower table blower motor output and drive required.

MINIMUM AIR VOLUME REQUIRED FOR USE WITH OPTIONAL ELECTRIC HEAT

- LCA/LHA models require 3000 cfm (1415 L/s) minimum air with electric heat in horizontal applications
- LCA/LHA models require 2600 cfm (1225 L/s) minimum air with electric heat in downflow applications

BOLD ITALICS INDICATE FIELD FURNISHED DRIVE.

Air Volume cfm (L/s)	Total Static Pressure - Inches Water Gauge (Pa)									
	0.20 (50)	0.40 (100)	0.60 (150)	0.80 (200)	1.00 (250)	1.20 (300)	1.40 (350)	1.60 (400)	1.80 (450)	2.00 (495)
	RPM BHP (kW)	RPM BHP (kW)	RPM BHP (kW)	RPM BHP (kW)	RPM BHP (kW)	RPM BHP (kW)	RPM BHP (kW)	RPM BHP (kW)	RPM BHP (kW)	RPM BHP (kW)
2000 (945)	625 0.40 <i>(.30)</i>	725 0.55 <i>(0.41)</i>	820 0.70 <i>(0.52)</i>	905 0.90 (0.67)	990 1.10 (0.82)	1065 1.30 (0.97)	1140 1.55 (1.16)	1215 1.85 (1.38)	1285 2.20 (1.64)	1350 2.50 <i>(1.87)</i>
2200 (1040)	670 0.50 <i>(.37)</i>	760 0.65 <i>(0.48)</i>	850 0.80 (0.60)	930 1.00 (0.75)	1010 1.20 (0.90)	1085 1.45 (1.08)	1155 1.70 (1.27)	1225 1.95 (1.45)	1290 2.25 (1.68)	1355 2.60 <i>(1.94)</i>
2400 (1135)	715 0.65 <i>(.48)</i>	800 0.80 <i>(0.60)</i>	880 0.95 (0.71)	960 1.15 (0.86)	1030 1.35 (1.01)	1105 1.60 (1.19)	1170 1.80 (1.34)	1240 2.10 (1.57)	1305 2.40 <i>(1.79)</i>	1365 2.70 <i>(2.01)</i>
2600 (1230)	760 0.80 <i>(.60)</i>	840 0.95 <i>(0.71)</i>	915 1.10 (0.82)	990 1.30 (0.97)	1060 1.50 (1.12)	1125 1.75 (1.31)	1195 2.00 (1.49)	1255 2.25 (1.68)	1320 2.55 <i>(1.90)</i>	1380 2.85 <i>(2.13)</i>
2800 (1325)	805 1.00 <i>(.75)</i>	880 1.15 (0.86)	955 1.30 (0.97)	1020 1.50 (1.12)	1090 1.70 (1.27)	1155 1.95 (1.45)	1215 2.20 (1.64)	1280 2.45 (1.83)	1335 2.70 <i>(2.01)</i>	1395 3.05 <i>(2.28)</i>
3000 (1420)	855 1.20 (.90)	925 1.35 (1.01)	990 1.50 (1.12)	1055 1.70 (1.27)	1120 1.95 (1.45)	1185 2.15 (1.60)	1245 2.40 (1.79)	1300 2.65 (1.98)	1360 2.95 <i>(2.20)</i>	1415 3.25 <i>(2.42)</i>
3200 (1510)	900 1.40 (1.04)	965 1.60 (1.19)	1030 1.75 (1.31)	1095 2.00 (1.49)	1155 2.20 (1.64)	1215 2.45 (1.83)	1270 2.65 (1.98)	1330 2.95 <i>(2.20)</i>	1385 3.25 <i>(2.42)</i>	1435 3.50 <i>(2.61)</i>
3400 (1605)	950 1.70 (1.27)	1010 1.85 (1.38)	1075 2.05 (1.53)	1130 2.25 (1.68)	1190 2.50 (1.87)	1245 2.70 (2.01)	1300 2.95 (2.20)	1355 3.25 <i>(2.42)</i>	1410 3.50 <i>(2.61)</i>	1460 3.80 <i>(2.83)</i>
3600 (1700)	995 1.95 (1.45)	1055 2.15 (1.60)	1115 2.35 (1.75)	1170 2.55 (1.90)	1225 2.80 (2.09)	1280 3.05 (2.28)	1335 3.30 <i>(2.46)</i>	1385 3.55 <i>(2.65)</i>	1440 3.85 <i>(2.87)</i>	1490 4.15 <i>(3.10)</i>
3800 (1795)	1045 2.30 (1.72)	1100 2.45 (1.83)	1160 2.70 (2.01)	1210 2.90 (2.16)	1265 3.15 (2.35)	1320 3.40 <i>(2.54)</i>	1370 3.65 <i>(2.72)</i>	1420 3.95 <i>(2.95)</i>	1470 4.25 <i>(3.17)</i>	1515 4.50 <i>(3.36)</i>
4000 (1890)	1095 2.65 (1.98)	1150 2.85 (2.13)	1200 3.05 (2.28)	1255 3.30 (2.46)	1305 3.55 <i>(2.65)</i>	1355 3.80 <i>(2.83)</i>	1405 4.05 <i>(3.02)</i>	1450 4.30 <i>(3.21)</i>	1500 4.60 <i>(3.43)</i>	1545 4.90 <i>(3.66)</i>

FACTORY INSTALLED DRIVE KIT SPECIFICATIONS

Motor Outputs				RPM Range			
Nominal hp	Maximum hp	Nominal kW	Maximum kW	Drive 1	Drive 2	Drive 3	Drive 4
2 Standard	2.30	1.5	1.7	845 - 1130	----	1015 - 1300	----
2 High Efficiency	2.30	1.5	1.7	845 - 1130	----	1015 - 1300	----
3 Standard	3.45	2.2	2.6	845 - 1130	----	1015 - 1300	----
3 High Efficiency	3.45	2.2	2.6	----	845 - 1130	----	1015 - 1300

*Using total air volume and system static pressure requirements determine from blower performance tables rpm and motor output required. Maximum usable output of motors furnished by Lennox are shown. In Canada, nominal motor output is also maximum usable motor output. If motors of comparable output are used, be sure to keep within the service factor limitations outlined on the motor nameplate.

BLOWER DATA 088 / 100 Cont.

FACTORY INSTALLED OPTIONS/FIELD INSTALLED ACCESSORY AIR RESISTANCE						
Air Volume		Total Resistance — inches water gauge (Pa)				
		Wet Indoor Coil	Gas Heat Exchanger (LGA Models)		Electric Heat (LCA/LHA Models)	Economizer
cfm	L/s		Low Fire	High Fire		
2000	945	0.06 (15)	0.05 (12)	0.08 (20)	0.13	0.03 (7)
2200	140	0.07 (17)	0.08 (20)	0.13 (32)	0.15	0.04 (10)
2400	1135	0.09 (22)	0.10 (25)	0.16 (40)	0.16	0.05 (12)
2600	1230	0.10 (25)	0.14 (35)	0.23 (57)	0.17	0.05 (12)
2800	1325	0.11 (27)	0.15 (37)	0.25 (62)	0.18	0.06 (15)
3000	1420	0.12 (30)	0.19 (47)	0.32 (80)	0.20	0.06 (15)
3200	1510	0.14 (35)	0.23 (57)	0.39 (97)	0.24	0.07 (17)
3400	1605	0.15 (37)	0.26 (65)	0.43 (107)	0.26	0.08 (20)
3600	1700	0.17 (42)	0.30 (75)	0.50 (124)	0.30	0.09 (22)
3800	1795	0.18 (45)	0.32 (80)	0.53 (132)	0.33	0.10 (25)
4000	1890	0.19 (47)	0.36 (90)	0.60 (149)	0.35	0.11 (27)

CEILING DIFFUSER AIR RESISTANCE						
Unit Size	Air Volume		Total Resistance — inches water gauge (Pa)			
			RTD11 Step-Down Diffuser			FD11 Flush Diffuser
	cfm	L/s	2 Ends Open	1 Side 2 Ends Open	All Ends & Sides Open	
088 & 100 Models	2400	1185	.21 (52)	.18 (.45)	.15 (37)	.14 (35)
	2600	1225	.24 (60)	.21 (52)	.18 (45)	.17 (42)
	2800	1320	.27 (67)	.24 (60)	.21 (52)	.20 (50)
	3000	1415	.32 (80)	.29 (72)	.25 (62)	.25 (62)
	3200	1510	.41 (102)	.37 (92)	.32 (80)	.31 (77)
	3400	1605	.50 (124)	.45 (112)	.39 (97)	.37 (92)
	3600	1700	.61 (152)	.54 (134)	.48 (119)	.44 (109)
	3800	1795	.73 (182)	.63 (157)	.57 (142)	.51 (127)

CEILING DIFFUSER AIR THROW DATA						
Model No.	Air Volume		*Effective Throw Range			
			RTD11 Step-Down		FD11 Flush	
	cfm	L/s	ft.	m	ft.	m
088 & 100 Models	3000	1415	27 - 33	8 - 10	25 - 30	8 - 9
	3375	1595	30 - 37	9 - 11	28 - 34	9 - 10
	3750	1770	34 - 41	10 - 12	31 - 38	9 - 12

*Throw is the horizontal or vertical distance an airstream travels on leaving the outlet or diffuser before the maximum velocity is reduced to 50 ft. (15 m) per minute. Four sides open.

POWER EXHAUST FANS PERFORMANCE			
Return Air System Static Pressure		Air Volume Exhausted	
in. w.g.	Pa	cfm	L/s
0	0	4200	1980
0.05	12	3970	1875
0.10	25	3750	1770
0.15	37	3520	1660
0.20	50	3300	1560
0.25	62	3080	1455
0.30	75	2860	1350
0.35	87	2640	1245

BLOWER DATA 090 / 150

BLOWER TABLE INCLUDES RESISTANCE FOR LCA102 BASE UNIT ONLY WITH DRY INDOOR COIL & AIR FILTERS IN PLACE.

FOR ALL UNITS ADD:

- 1 - Wet indoor coil air resistance of selected unit.
- 2 - Any factory installed options air resistance (heat section, economizer, etc.)
- 3 - Any field installed accessories air resistance (duct resistance, diffuser, etc.)

Then determine from blower table blower motor output and drive required.

MINIMUM AIR VOLUME REQUIRED FOR USE WITH OPTIONAL ELECTRIC HEAT

LCA102 requires 3000 cfm (1415 L/s) minimum air with electric heat.
 LCA120 & LCA150 models require 4000 cfm (1890 L/s) minimum air with electric heat.

BOLD ITALIC INDICATES FIELD FURNISHED DRIVE

Air Volume cfm (L/s)	Total Static Pressure - in. w.g. (Pa)													
	.20 (50)	.40 (100)	.60 (150)	.80 (200)	1.00 (250)	1.20 (300)	1.40 (350)	1.60 (400)	1.80 (450)	2.00 (495)	2.20 (545)	2.40 (595)	2.60 (645)	
	RPM BHP (kW)	RPM BHP (kW)	RPM BHP (kW)	RPM BHP (kW)	RPM BHP (kW)	RPM BHP (kW)	RPM BHP (kW)	RPM BHP (kW)	RPM BHP (kW)	RPM BHP (kW)	RPM BHP (kW)	RPM BHP (kW)	RPM BHP (kW)	RPM BHP (kW)
2250 (1060)	455 0.30 <i>(0.22)</i>	555 0.45 <i>(0.34)</i>	640 0.60 <i>(0.45)</i>	720 0.80 (0.60)	790 1.00 (0.75)	855 1.20 (0.90)	915 1.40 (1.04)	975 1.60 (1.19)	1030 1.85 (1.38)	1080 2.05 (1.53)	1130 2.30 (1.72)	1175 2.55 (1.90)	1220 2.80 (2.09)	
2500 (1180)	475 0.40 <i>(0.30)</i>	575 0.55 <i>(0.41)</i>	660 0.70 <i>(0.52)</i>	735 0.90 (0.67)	805 1.10 (0.82)	870 1.30 (0.97)	930 1.55 (1.16)	985 1.75 (1.31)	1040 2.00 (1.49)	1090 2.25 (1.68)	1140 2.50 (1.87)	1185 2.75 (2.05)	1230 3.00 (2.24)	
2750 (1300)	495 0.45 <i>(0.34)</i>	595 0.65 <i>(0.48)</i>	675 0.85 <i>(0.63)</i>	750 1.05 (0.78)	820 1.25 (0.93)	885 1.45 (1.08)	940 1.70 (1.27)	995 1.90 (1.42)	1050 2.20 (1.64)	1100 2.45 (1.83)	1145 2.65 (1.98)	1195 2.95 (2.20)	1240 3.25 (2.42)	
3000 (1415)	525 0.55 <i>(0.41)</i>	615 0.75 <i>(0.56)</i>	695 0.95 (0.71)	770 1.20 (0.90)	835 1.40 (1.04)	895 1.60 (1.19)	955 1.85 (1.38)	1010 2.10 (1.57)	1060 2.35 (1.75)	1110 2.65 (1.98)	1160 2.90 (2.16)	1205 3.20 (2.39)	1250 3.45 (2.57)	
3250 (1535)	550 0.65 <i>(0.48)</i>	640 0.90 <i>(0.67)</i>	715 1.10 (0.82)	790 1.35 (1.01)	855 1.60 (1.19)	915 1.80 (1.34)	970 2.05 (1.53)	1025 2.35 (1.75)	1075 2.60 (1.94)	1125 2.85 (2.13)	1170 3.15 (2.35)	1215 3.40 (2.54)	1260 3.70 (2.76)	
3500 (1650)	580 0.80 <i>(0.60)</i>	665 1.05 <i>(0.78)</i>	740 1.25 (0.93)	810 1.50 (1.12)	870 1.75 (1.31)	930 2.00 (1.49)	985 2.25 (1.68)	1040 2.55 (1.90)	1090 2.85 (2.13)	1135 3.10 (2.31)	1185 3.40 (2.54)	1230 3.70 (2.76)	1270 4.00 (2.98)	
3750 (1770)	605 0.95 <i>(0.71)</i>	690 1.20 (0.90)	760 1.45 (1.08)	830 1.70 (1.27)	890 1.95 (1.45)	950 2.25 (1.68)	1005 2.50 (1.87)	1055 2.80 (2.09)	1105 3.10 (2.31)	1150 3.35 (2.50)	1195 3.65 (2.72)	1240 3.95 (2.95)	1285 4.30 (3.21)	
4000 (1890)	635 1.10 <i>(0.82)</i>	715 1.40 (1.04)	785 1.65 (1.23)	850 1.90 (1.42)	910 2.20 (1.64)	965 2.45 (1.83)	1020 2.75 (2.05)	1070 3.05 (2.28)	1120 3.35 (2.50)	1165 3.65 (2.72)	1210 3.95 (2.95)	1255 4.30 (3.21)	1295 4.60 (3.43)	
4250 (2005)	665 1.30 <i>(0.97)</i>	740 1.60 (1.19)	810 1.85 (1.38)	870 2.15 (1.60)	930 2.45 (1.83)	985 2.75 (2.05)	1040 3.05 (2.28)	1090 3.35 (2.50)	1135 3.65 (2.72)	1185 4.00 (2.98)	1225 4.30 (3.21)	1270 4.65 (3.47)	1310 4.95 (3.69)	
4500 (2125)	695 1.50 (1.12)	770 1.80 (1.34)	835 2.10 (1.57)	895 2.40 (1.79)	955 2.70 (2.01)	1005 3.00 (2.24)	1060 3.35 (2.50)	1105 3.65 (2.72)	1155 4.00 (2.98)	1200 4.30 (3.21)	1245 4.65 (3.47)	1285 5.00 (3.73)	1325 5.30 (3.95)	
4750 (2240)	725 1.75 (1.31)	795 2.05 (1.53)	860 2.40 (1.79)	920 2.70 (2.01)	975 3.00 (2.24)	1030 3.35 (2.50)	1080 3.65 (2.72)	1125 3.95 (2.95)	1175 4.35 (3.25)	1215 4.65 (3.47)	1260 5.00 (3.73)	1300 5.35 (3.99)	1340 5.70 (4.25)	
5000 (2360)	760 2.05 (1.53)	825 2.35 (1.75)	885 2.65 (1.98)	945 3.00 (2.24)	1000 3.35 (2.50)	1050 3.65 (2.72)	1100 4.00 (2.98)	1145 4.35 (3.25)	1190 4.70 (3.51)	1235 5.05 (3.77)	1280 5.45 (4.07)	-----	-----	
5250 (2475)	790 2.30 (1.72)	855 2.65 (1.98)	910 2.95 (2.20)	970 3.35 (2.50)	1020 3.65 (2.72)	1070 4.00 (2.98)	1120 4.35 (3.25)	1165 4.70 (3.51)	1210 5.10 (3.80)	1255 5.45 (4.07)	-----	-----	-----	
5500 (2595)	820 2.60 (1.94)	880 2.95 (2.20)	940 3.30 (2.46)	995 3.70 (2.76)	1045 4.05 (3.02)	1095 4.40 (3.28)	1145 4.80 (3.58)	1190 5.15 (3.84)	1230 5.50 (4.10)	-----	-----	-----	-----	
5750 (2715)	850 2.95 (2.20)	910 3.30 (2.46)	965 3.70 (2.76)	1020 4.05 (3.02)	1070 4.45 (3.32)	1120 4.80 (3.58)	1165 5.20 (3.88)	1210 5.60 (4.18)	-----	-----	-----	-----	-----	
6000 (2830)	885 3.35 (2.50)	940 3.70 (2.76)	995 4.10 (3.06)	1045 4.45 (3.32)	1095 4.85 (3.62)	1145 5.25 (3.92)	1190 5.65 (4.21)	-----	-----	-----	-----	-----	-----	

FACTORY INSTALLED DRIVE KIT SPECIFICATIONS

Motor Outputs				RPM Range					
Nominal hp	Maximum hp	Nominal kW	Maximum kW	Drive 1	Drive 2	Drive 3	Drive 4	Drive 5	Drive 6
2	2.3	1.5	1.7	680 - 940	-----	850 - 1130	-----	-----	-----
3 Standard	3.45	2.2	2.6	680 - 940	-----	850 - 1130	-----	1105 - 1410	-----
3 High Efficiency	3.45	2.2	2.6	-----	680 - 895	-----	895 - 1120	-----	1110 - 1395
5	5.75	3.7	4.3	-----	-----	-----	895 - 1120	-----	1110 - 1395

NOTE — Using total air volume and system static pressure requirements determine from blower performance tables rpm and motor output required. Maximum usable output of motors furnished by Lennox are shown. In Canada, nominal motor output is also maximum usable motor output. If motors of comparable output are used, be sure to keep within the service factor limitations outlined on the motor nameplate.

BLOWER DATA 090 / 150 Cont.

FACTORY INSTALLED OPTIONS/FIELD INSTALLED ACCESSORY AIR RESISTANCE							
Air Volume		Total Resistance — inches water gauge (Pa)					
		Wet Indoor Coil		Gas Heat Exchanger (LGA Models)		Electric Heat (LCA/LHA Models)	Economizer
cfm	L/s	102S, 102H, 120S, 150S	120H	Low Fire	High Fire		
2250	1060	.06 (15)	.10 (25)	.05 (12)	.09 (22)	.01 (2)	.035 (9)
2500	1180	.08 (20)	.12 (30)	.05 (12)	.11 (27)	.01 (2)	.04 (10)
2750	1300	.09 (22)	.14 (35)	.06 (15)	.13 (32)	.01 (2)	.045 (11)
3000	1415	.10 (25)	.16 (40)	.07 (17)	.16 (40)	.02 (5)	.05 (12)
3250	1535	.11 (27)	.19 (47)	.08 (20)	.19 (47)	.02 (5)	.06 (15)
3500	1650	.13 (32)	.21 (52)	.09 (22)	.22 (55)	.03 (7)	.07 (17)
3750	1770	.14 (35)	.23 (57)	.10 (25)	.26 (65)	.03 (7)	.075 (19)
4000	1890	.16 (40)	.26 (65)	.11 (27)	.30 (75)	.04 (10)	.08 (20)
4250	2005	.17 (42)	.28 (70)	.12 (30)	.34 (85)	.04 (10)	.09 (22)
4500	2125	.18 (45)	.31 (77)	.13 (32)	.38 (94)	.05 (12)	.10 (25)
4750	2240	.20 (50)	.33 (82)	.14 (35)	.42 (104)	.05 (12)	.11 (27)
5000	2360	.22 (55)	.36 (90)	.16 (40)	.47 (117)	.06 (15)	.12 (30)
5250	2475	.24 (60)	.39 (97)	.18 (45)	.52 (129)	.06 (15)	.13 (32)
5500	2595	.26 (65)	.42 (104)	.20 (50)	.57 (142)	.07 (17)	.14 (35)
5750	2715	.28 (70)	.45 (112)	.22 (55)	.62 (154)	.07 (17)	.15 (37)
6000	2830	.30 (75)	.48 (119)	.24 (60)	.68 (169)	.08 (20)	.16 (40)

CEILING DIFFUSER AIR RESISTANCE						
Unit Size	Air Volume		Total Resistance — inches water gauge (Pa)			
			RTD11 Step-Down Diffuser			FD11 Flush Diffuser
	cfm	L/s	2 Ends Open	1 Side, 2 Ends Open	All Ends & Sides Open	
102 & 120 Models	3600	1700	.36 (90)	.28 (70)	.23 (57)	.15 (37)
	3800	1795	.40 (99)	.32 (80)	.26 (65)	.18 (45)
	4000	1890	.44 (109)	.36 (90)	.29 (72)	.21 (52)
	4200	1980	.49 (122)	.40 (99)	.33 (82)	.24 (60)
	4400	2075	.54 (134)	.44 (109)	.37 (92)	.27 (67)
	4600	2170	.60 (149)	.49 (122)	.42 (104)	.31 (77)
	4800	2265	.65 (162)	.53 (132)	.46 (114)	.35 (87)
	5000	2360	.69 (172)	.58 (144)	.50 (124)	.39 (97)
150 Models	5200	2455	.75 (186)	.62 (154)	.54 (134)	.43 (107)
	4200	1980	.22 (55)	.19 (47)	.16 (40)	.10 (25)
	4400	2075	.28 (70)	.24 (60)	.20 (50)	.12 (30)
	4600	2170	.34 (85)	.29 (72)	.24 (60)	.15 (37)
	4800	2265	.40 (99)	.34 (85)	.29 (72)	.19 (47)
	5000	2360	.46 (114)	.39 (97)	.34 (85)	.23 (57)
	5200	2455	.52 (129)	.44 (109)	.39 (97)	.27 (67)
	5400	2550	.58 (144)	.49 (122)	.43 (107)	.31 (77)
5600	2645	.64 (159)	.54 (134)	.47 (117)	.35 (87)	
5800	2735	.70 (174)	.59 (147)	.51 (127)	.39 (97)	

POWER EXHAUST FANS PERFORMANCE			
Return Air System Static Pressure		Air Volume Exhausted	
in. w.g.	Pa	cfm	L/s
0	0	4200	1980
0.05	12	3970	1875
0.10	25	3750	1770
0.15	37	3520	1660
0.20	50	3300	1560
0.25	62	3080	1455
0.30	75	2860	1350
0.35	87	2640	1245

CEILING DIFFUSER AIR THROW DATA						
Model No.	Air Volume		*Effective Throw Range			
			RTD11 Step-Down		FD11 Flush	
	cfm	L/s	ft.	m	ft.	m
102 & 120 Models	4400	2075	34 - 42	10 - 13	32 - 40	10 - 12
	4950	2335	38 - 47	12 - 14	36 - 45	11 - 14
	5500	2595	43 - 52	13 - 16	40 - 50	12 - 15
150 Models	4200	1980	39 - 46	12 - 14	40 - 48	12 - 15
	5000	2360	41 - 50	12 - 15	43 - 52	13 - 16
	5800	2735	43 - 52	13 - 16	45 - 54	14 - 16

*Throw is the horizontal or vertical distance an airstream travels on leaving the outlet or diffuser before the maximum velocity is reduced to 50 ft. (15 m) per minute. Four sides open.

LGA/LCA088 / 100 PARTS ARRANGEMENT

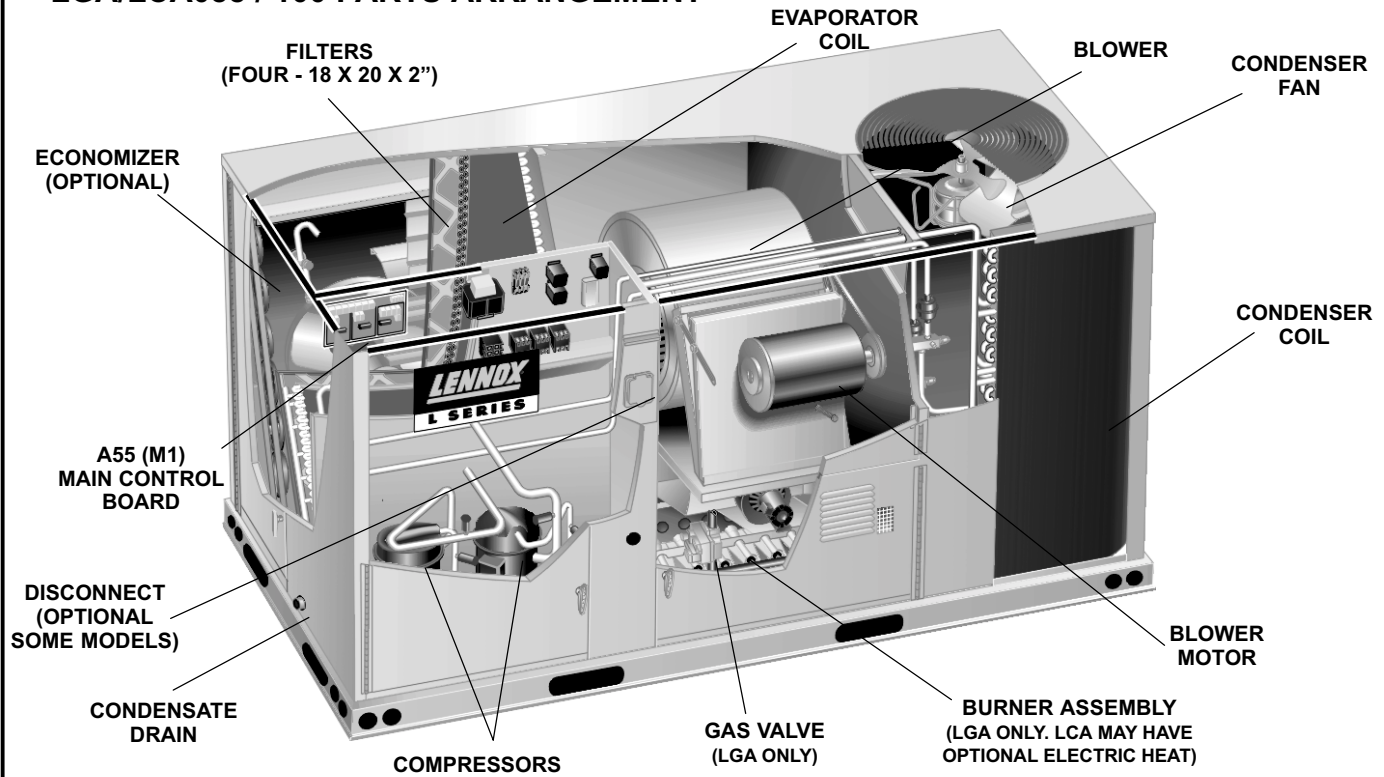

FIGURE 1

LHA088 PARTS ARRANGEMENT

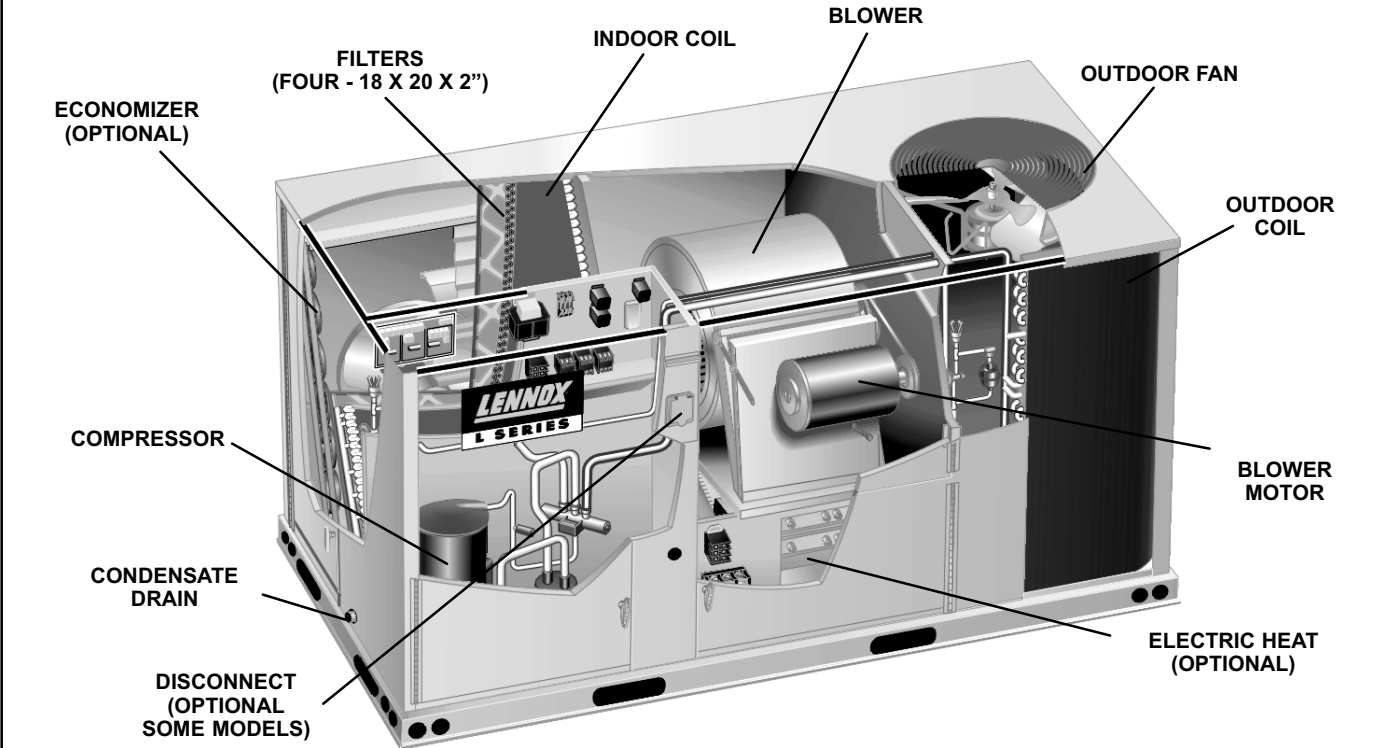

FIGURE 2

LGA/LCA120 PARTS ARRANGEMENT

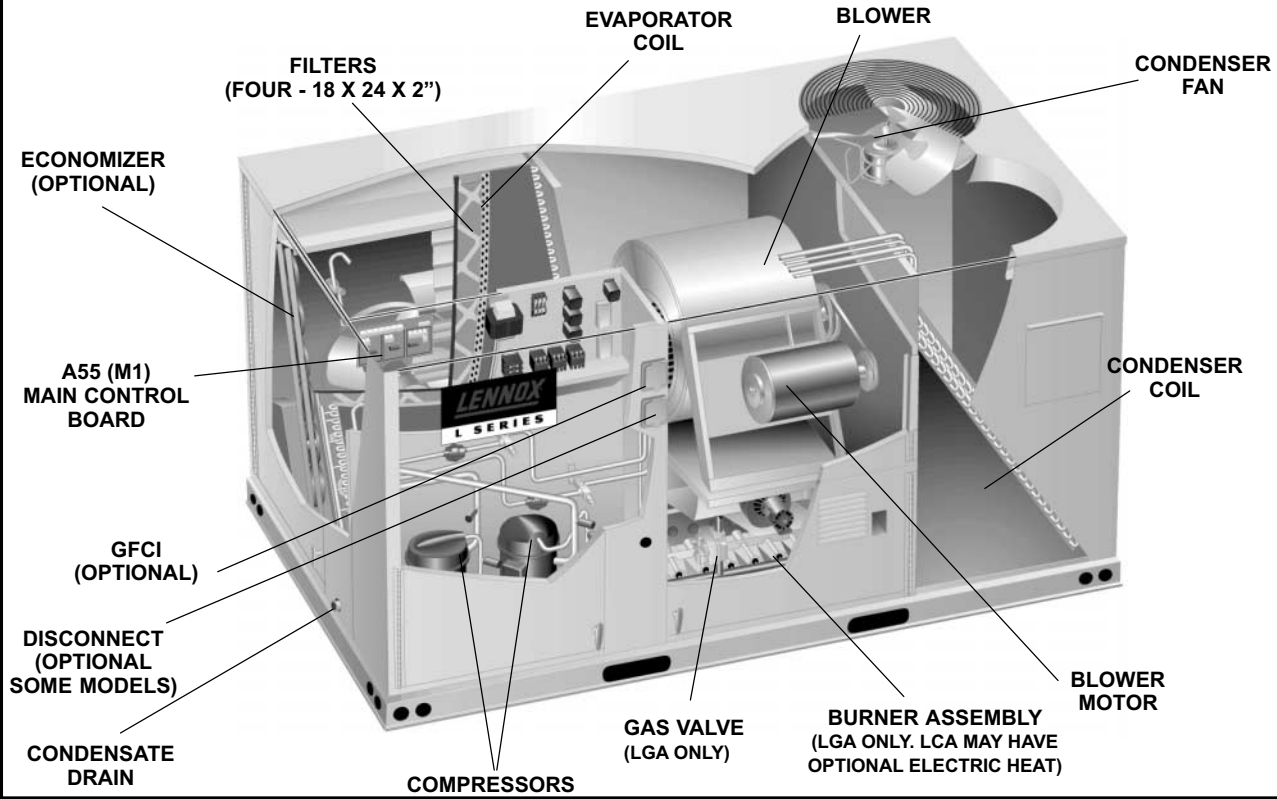

FIGURE 3

LHA120 PARTS ARRANGEMENT

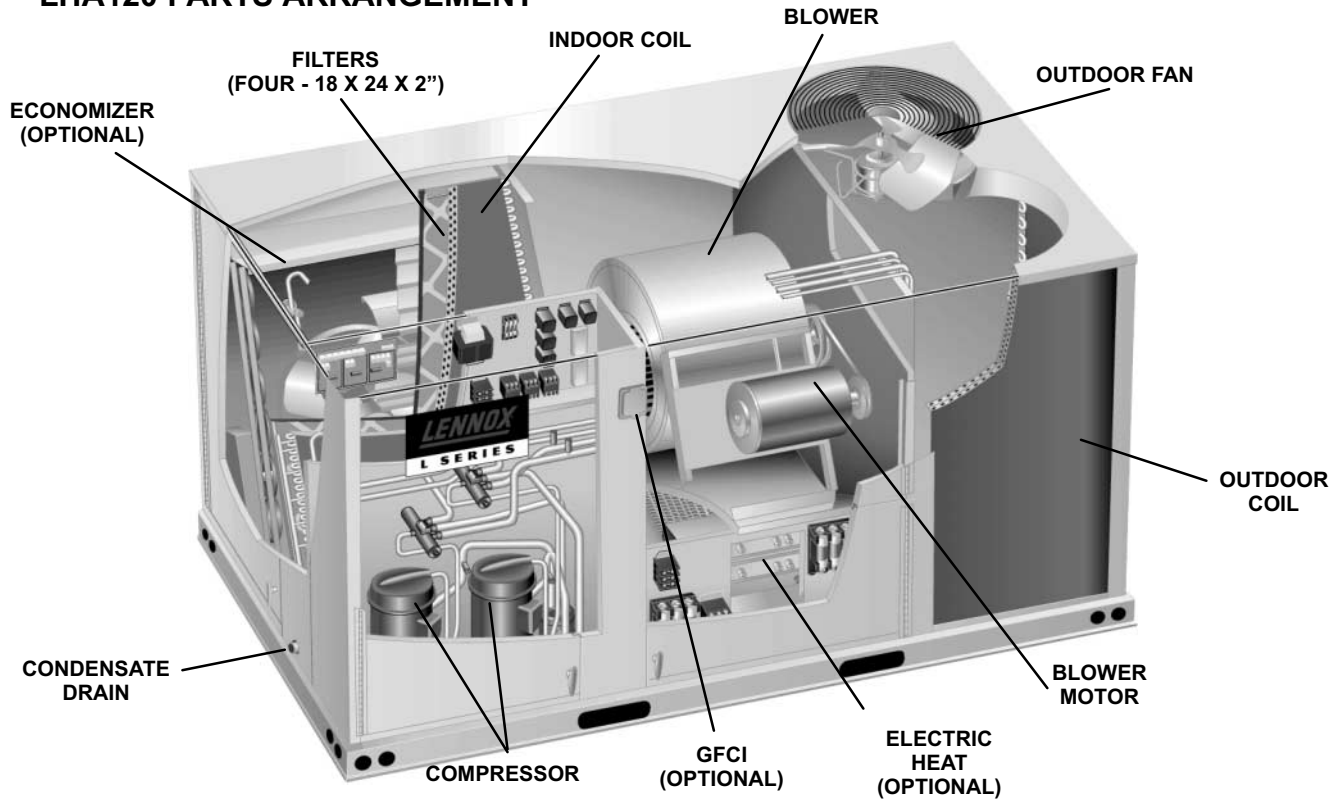

FIGURE 4

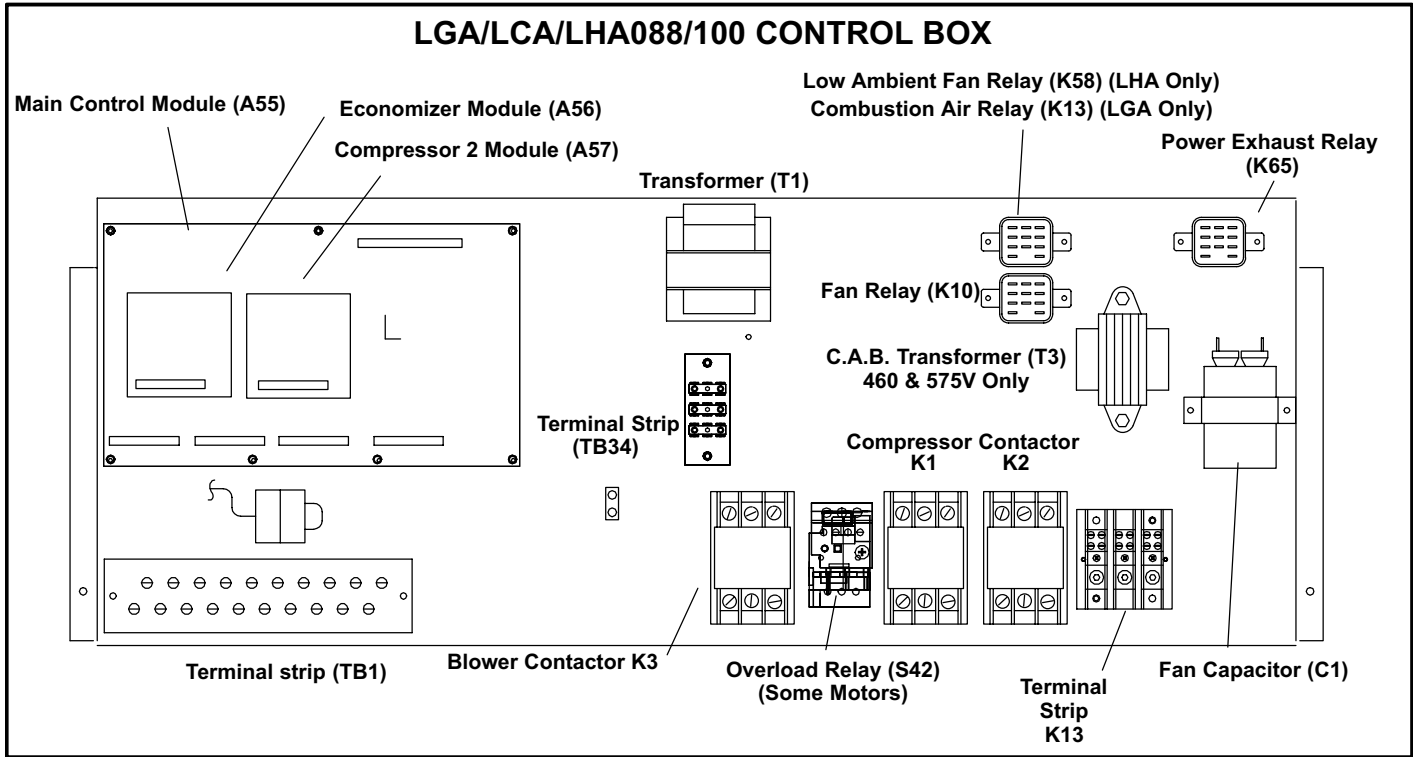

FIGURE 5

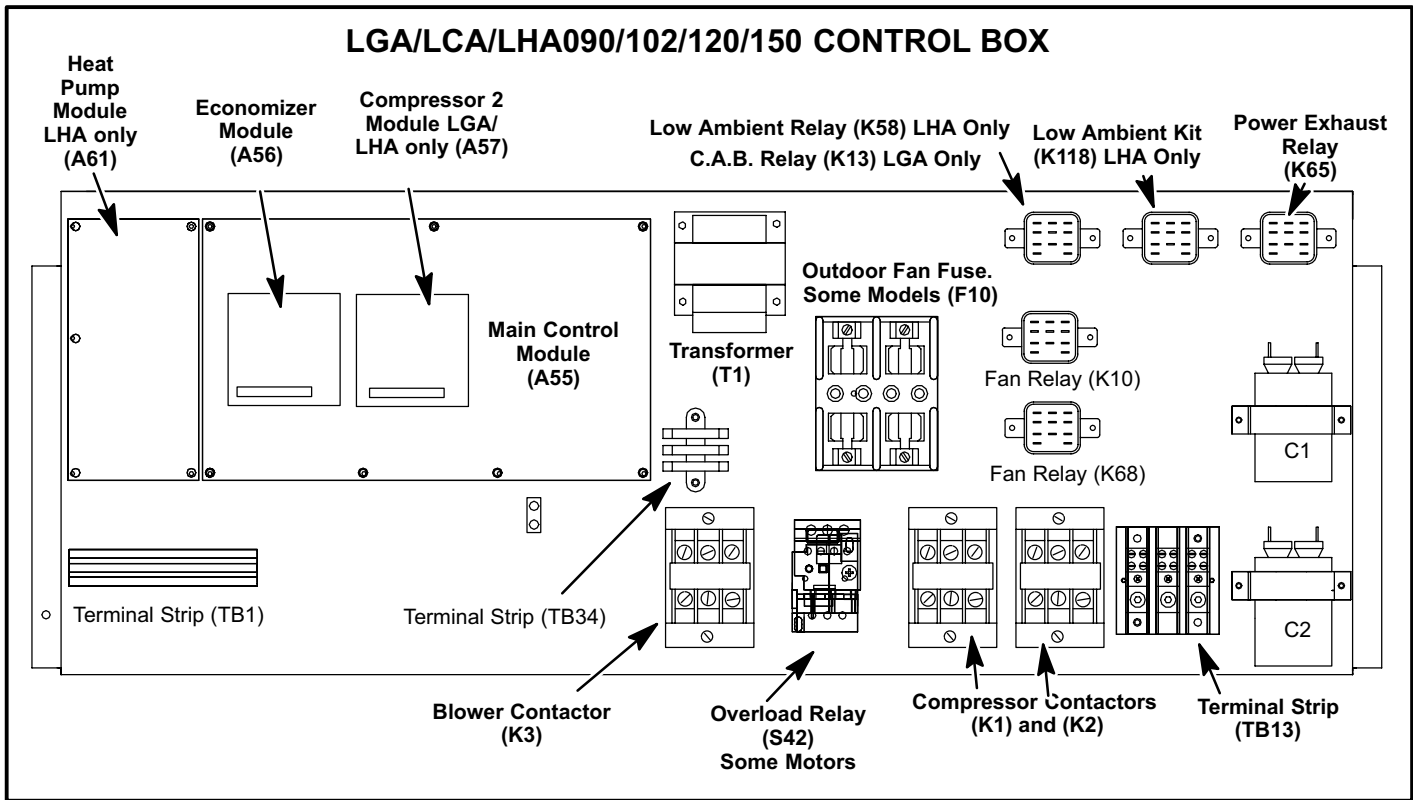

FIGURE 6

I-UNIT COMPONENTS

LGA /LCA /LHA 7.5, 8.5, 10 and 12 ton (26.3, 35.2 and 42.2 kW) units are configured to order units (CTO). The LGA/LCA/LHA unit parts arrangement are shown in figures 1 through 4. All L1, L2, and L3 wiring is color coded; L1 is red, L2 is yellow, and L3 is blue. See wiring diagrams in the back of this manual for complete call out of components per LGA/LCA/LHA unit.

A-Control Box Components

LGA/LCA/LHA control box components are shown in figures 5 and 6. The control box is located in the upper portion of the compressor compartment.

1-Disconnect Switch S48 (Optional all units)

LGA/LCA/LHA units may be equipped with an optional disconnect switch S48. Other factory or field installed optional circuit breakers may be used, such as CB10. S48 and CB10 are toggle switches, which can be used by the service technician to disconnect power to the unit.

2-Control Transformer T1 (all units)

All LGA/LCA/LHA series units use a single line voltage to 24VAC transformer mounted in the control box. Transformer supplies power to control circuits in the unit. The transformer is rated at 70VA and is protected by a 3.5 amp circuit breaker (CB8). The 208/230 (Y) volt-

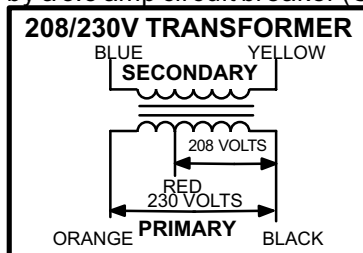

FIGURE 7

3-C. A. B. Transformers T3 (LGA 460V & 575V units)

All LGA 460 (G) and 575 (J) voltage units use one auto voltage to 230VAC transformer mounted in the control box. The transformer has an output rating of 0.5A. T3 transformer supplies 230 VAC power to combustion air blower motor (B6).

4-Terminal Strips TB1, TB13, TB34 (all units)

TB1 terminal strip distributes 24V power and common from the thermostat to the control box components. TB13 terminal strip distributes line voltage power to the line voltage items in the unit. TB34 terminal strip distributes 24V power from T1 to the control box components.

5-Unit Fuse Block & Fuses F4 (LHA & LCA units)

Three line voltage fuses F4 provide short circuit and ground fault protection to all cooling components in the LHA and LCA units with electric heat. The fuses are rated in accordance with the amperage of the cooling components.

6-Outdoor Fan Capacitor C1 and C2

Fan capacitors C1 and C2 are 370V/10MF capacitors used to assist in the start up of condenser fan motors B4 and B5. Capacitor ratings will be on outdoor fan motor nameplate.

7-Compressor Contactor K1 & K2

All compressor contactors are three-pole-double-break contactors with a 24VAC coil. In all LGA/LCA/LHA units, K1 (energized by A55) and K2 (energized by A57 or A61), energize compressors B1 and B2 respectively in response to first or second stage cooling demands.

8-Blower Contactor K3

Blower contactor K3, used in all units, is a three-pole-double-break contactor with a 24VAC coil used to energize the indoor blower motor B3 in response to blower demand. K3 is energized by main control panel (A55).

9-Outdoor Fan Relay K10 and K68

Outdoor fan relay K10 and K68 are DPDT relays with a 24VAC coil. K10 and K68 (energized by A55), energizes condenser fan motors B4 and B5 in response to Y1 demand. In all LHA090/120 units, K10 energizes condenser fan B4 in response to Y1 demand and K68 energizes B5 in response to Y2 demand.

10-Combustion Air Inducer Relay K13 (LGA units)

Combustion air inducer relay K13, used in all LGA units, is a DPDT relay with a 24VAC coil. K13 is energized by the main control module A55 after a first stage heating demand from the thermostat. K13 remains energized throughout the heating demand. When energized, K13 N.O. contacts close to energize the combustion air inducer and begin first stage heat. Prove switch S18, located in the gas heat compartment, closes as combustion air static pressure falls to "prove" combustion air inducer operation. When S18 closes, the ignition control and gas valve is energized to begin first stage heat.

11-Low Ambient Bypass Fan Relay K58 and K118 (LHA units)

Low ambient bypass relay K58 and K118, are N.C. DPDT relays with a 24VAC coil. K58 is wired in parallel with the compressor reversing valve (L1) and K118 is wired in parallel with compressor reversing valve (L2). Both are energized by A55. When L1 is energized (stage one) in the cooling cycle, K58 is also energized, opening K58-1. Therefore, K58-1 is always closed during heating demand bypassing S11. This allows the fan to operate during heating demand and to cycle during cooling demand. When L2 is energized (stage two) in the cooling cycle, K118 is also energized, opening K118-1. Therefore, K118-1 is always closed during heating demand bypassing S84. This allows the fan to operate during heating demand and to cycle during cooling demand.

12-Power Exhaust Relay K65 (PED units)

Power exhaust relay K65 is a N.O. DPDT relay with a 24VAC coil. K65 is used in all LGA/LCA/LHA units equipped with the optional power exhaust dampers. K65 is energized by the economizer control panel (A56), after the economizer dampers reach 50% open (adjustable in ECTO). When K65 closes, the exhaust fan B10 is energized.

13-Blower Motor Overload Relay S42 (units with high efficiency motors and 50hz models)

The blower motor overload relay is used in all L series units equipped with high efficiency motors and all 50hz motors. The relay (S42) is connected in line with the blower motor to monitor the current flow to the motor. When the relay senses an overload condition, a set of normally closed contacts open to de-energize pin #9 in plug 110 of the A55 main control module. A55 de-energizes all outputs. The overload relay has an adjustable setting and is set per the nameplate current of the motor. All units are equipped with a relay manufactured by Siemens figure 8 or Telemecanique figure 9 .

INTEGRATED MODULAR CONTROL BOARDS

The Integrated Modular Control (IMC) is a series of control boards which integrates most control functions required for the LGA/LCA/LHA units. The control boards are located in the upper left hand corner of the control box. The control includes complete unit diagnostics with permanent code storage, field programmable control parameters and control options, on-site testing, and serial communications. Three different printed circuit boards (see figure 10) make-up the modular configurations for the LGA/LCA/LHA units. See table 1 for a list of control panels used for each unit. For further information refer to Integrated Modular Control Guide sent with each unit.

TABLE 1

UNIT	CONTROL PANELS		
	A55	A57	A56
LGA	X	X	OPT
LCA	X	X	OPT
LHA	X	A61 (090, 120 only)	OPT

14-Main Control Module A55 (all units)

The main control module A55 is the heart of the system. It controls one compressor, one two-stage gas valve, one bank of electric heat, one outdoor fan, and one blower. A55 includes the thermostat inputs, serial communications ports, diagnostic code display, control pushbutton, system configuration dip switches, and four expansion ports. A diagnostic code list is located on the back side of the access panel.

15-Compressor 2 Control Module A57 (LGA & LCA units)

The compressor 2 control module A57 controls one additional compressor stage for the LGA/LCA units. A57 includes all inputs and outputs required for compressor and fan control, compressor stages, diagnostics, and low ambient control.

16-Economizer Control Module A56 (Economizer only)

The economizer control module A56 controls the economizer. A56 has four different cooling modes, sensible temperature, outdoor enthalpy, differential enthalpy, and global control.

17-Heat Pump Control Module A61 (LHA-090/120 only)

The heat pump control module A61 is used to control the second compressor stage on the LHA units. A61 includes all inputs and outputs required for compressor and fan control, compressor stage diagnostics and low ambient control.

SIEMENS OVERLOAD RELAY

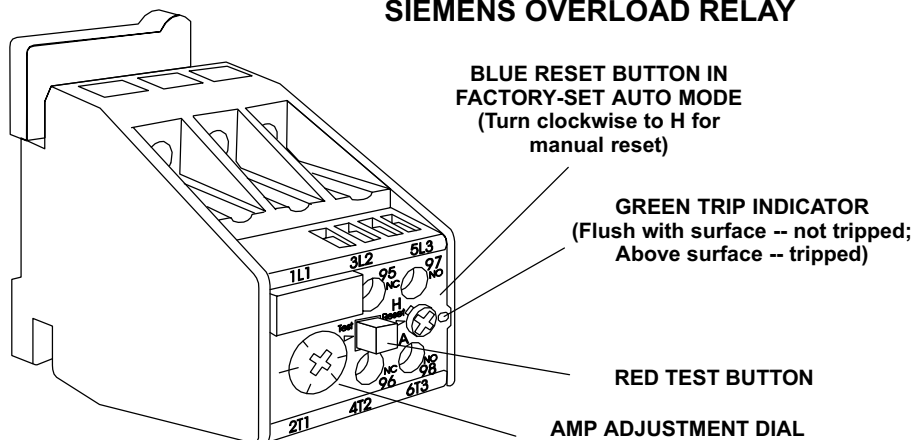

Adjust relay amp setting according to value given on the blower motor nameplate. Proper relay amp setting equals motor nameplate FLA X service factor of 1.15 X .95. Use small slotted screwdriver to adjust control mode from automatic reset (A) to manual reset (H). Control must be in the manual reset mode (H) to perform a test. Press the red test button. Green trip indicator should pop out. Press the blue reset screw to reset the relay.

FIGURE 8

TELEMECANIQUE OVERLOAD RELAY

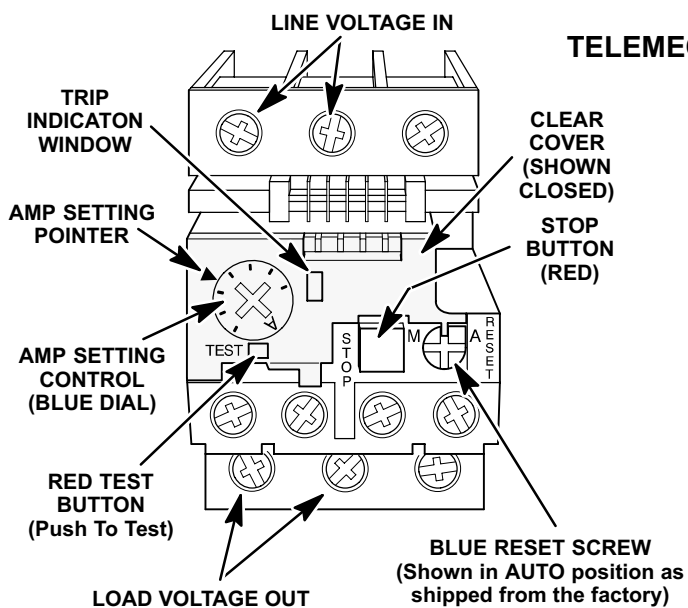

DETAIL SHOWING RESET BUTTON ADJUSTED TO MANUAL POSITION
Lift clear cover and turn adjustment screw counterclockwise. Reset screw will pop out when pointer is in M (manual position). Close cover to lock reset screw into position.

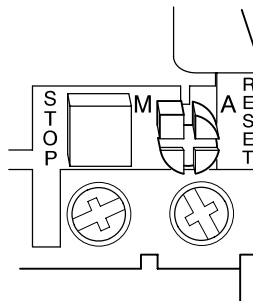

Lift clear cover to adjust relay amp setting according to value given on the blower motor nameplate. Proper relay amp setting equals motor nameplate FLA X service factor of 1.15 X .95. Cover must also be lifted to adjust control mode from automatic reset to manual reset (see detail above) and to test the control. Control must be in the manual reset mode to perform a test. Use a pointed object to press the small red test button. A yellow marker should appear in the trip indication window to the right of the amp setting control. Press the blue reset screw to reset the relay. The red STOP button opens the normally closed contacts which power the blower motor. This button stops blower motor operation as long as it is pressed in.

FIGURE 9

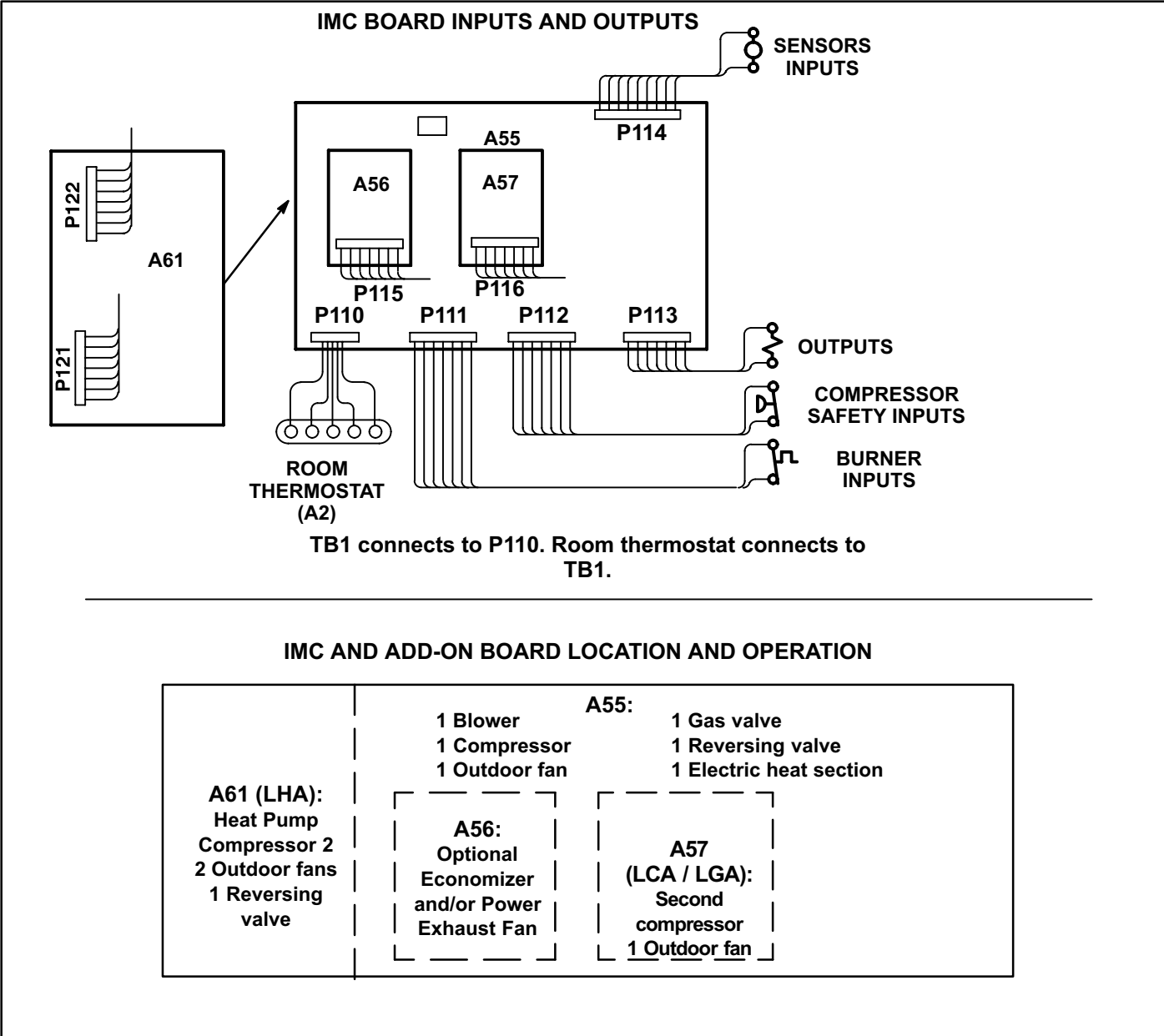
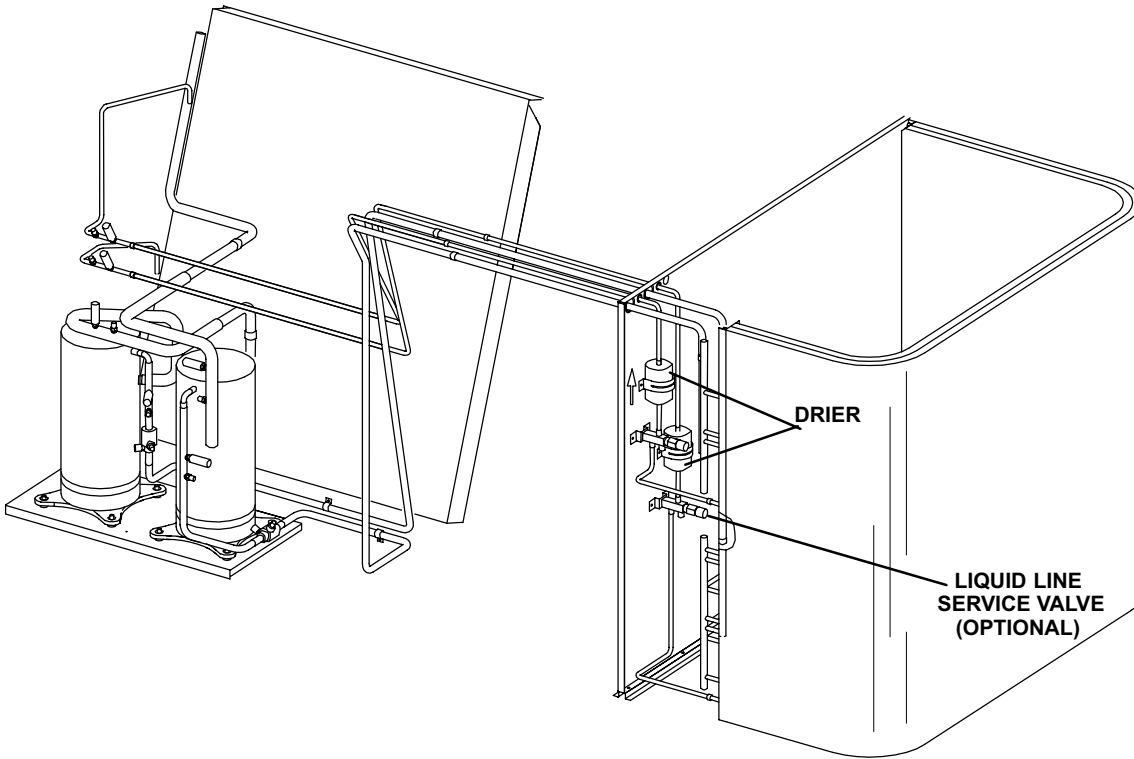

FIGURE 10

LGA/LCA088-100 PLUMBING COMPONENTS



LGA/LCA088-100 COMPRESSOR DETAIL

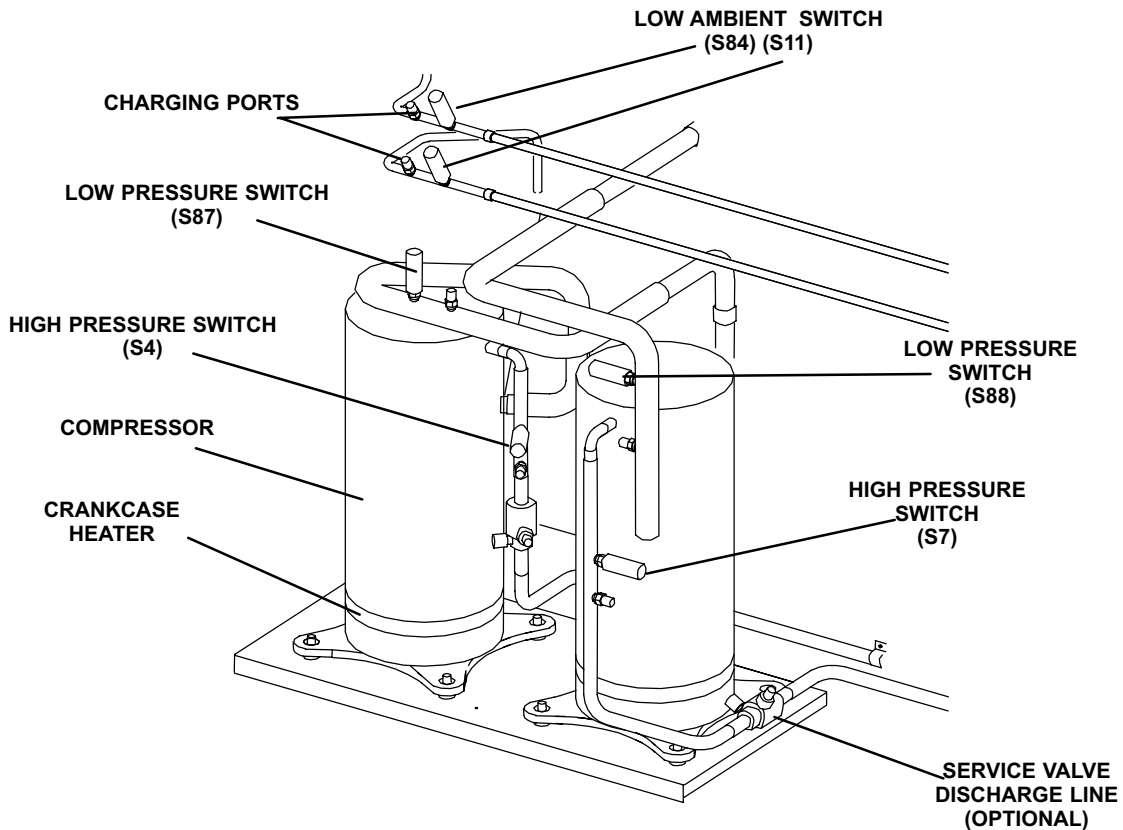
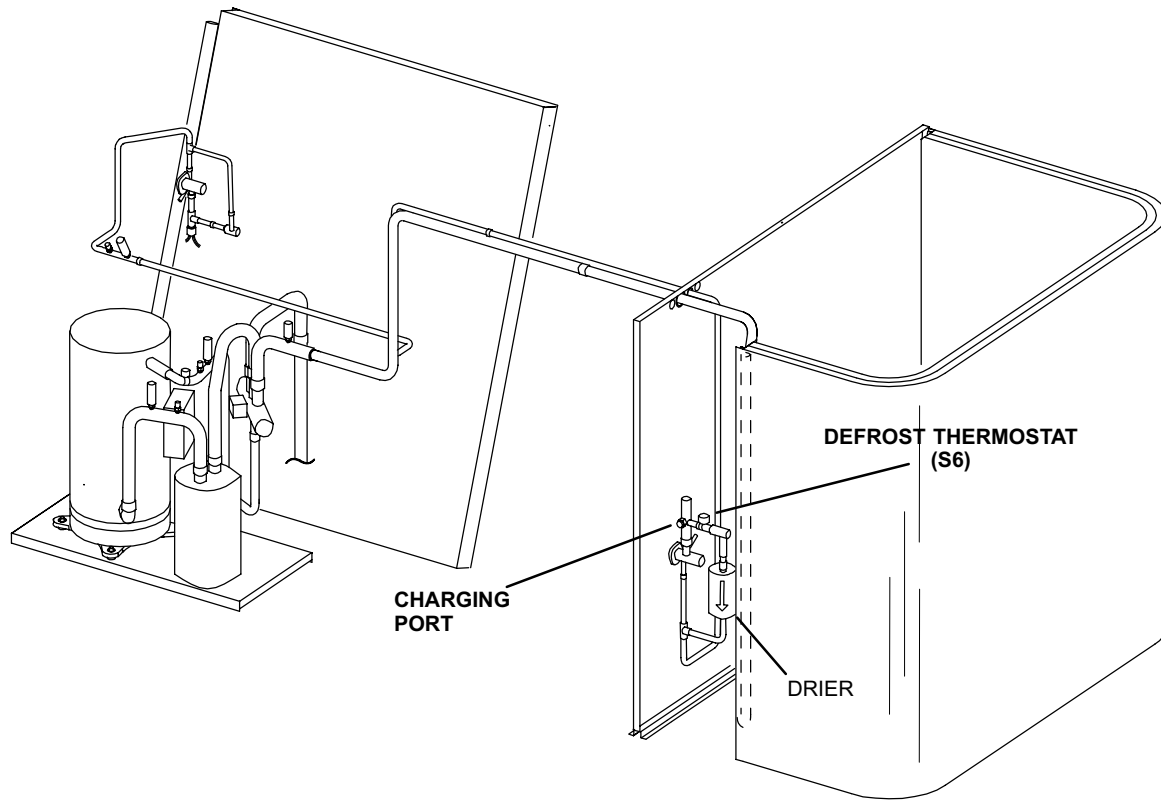

FIGURE 11

LHA088 PLUMBING COMPONENTS



LHA088 COMPRESSOR DETAIL

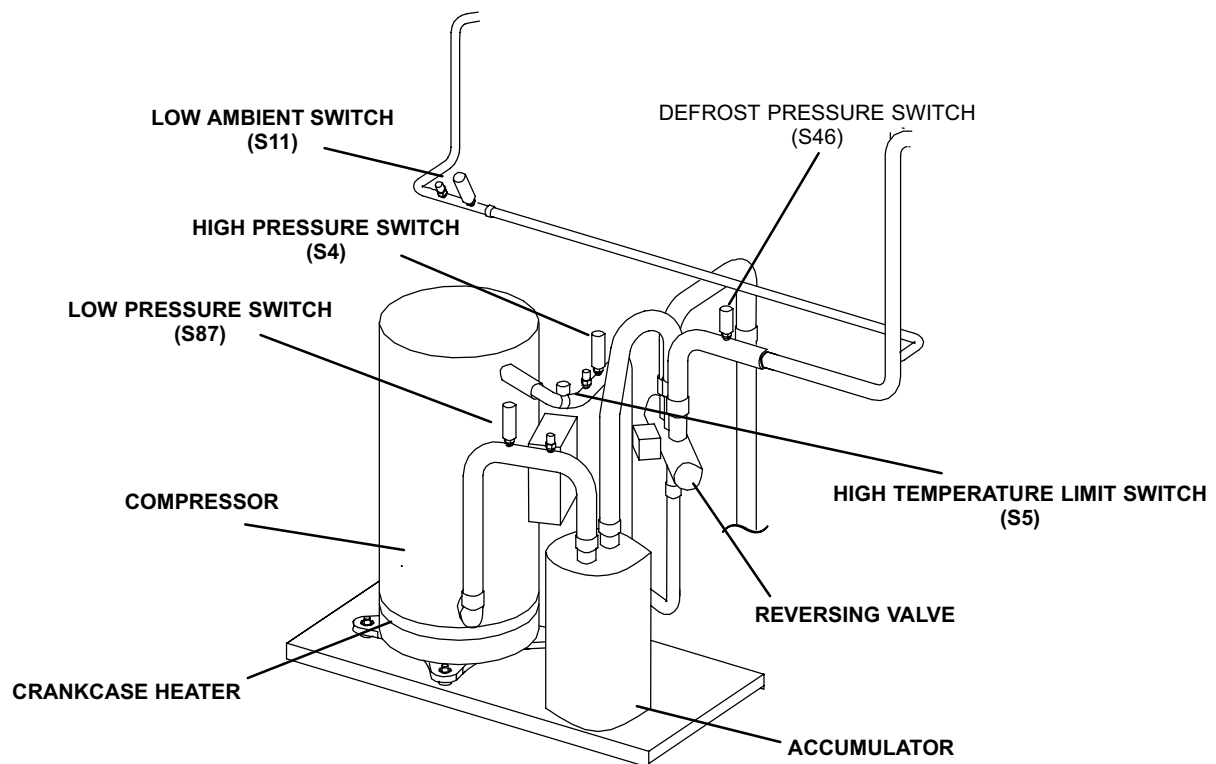
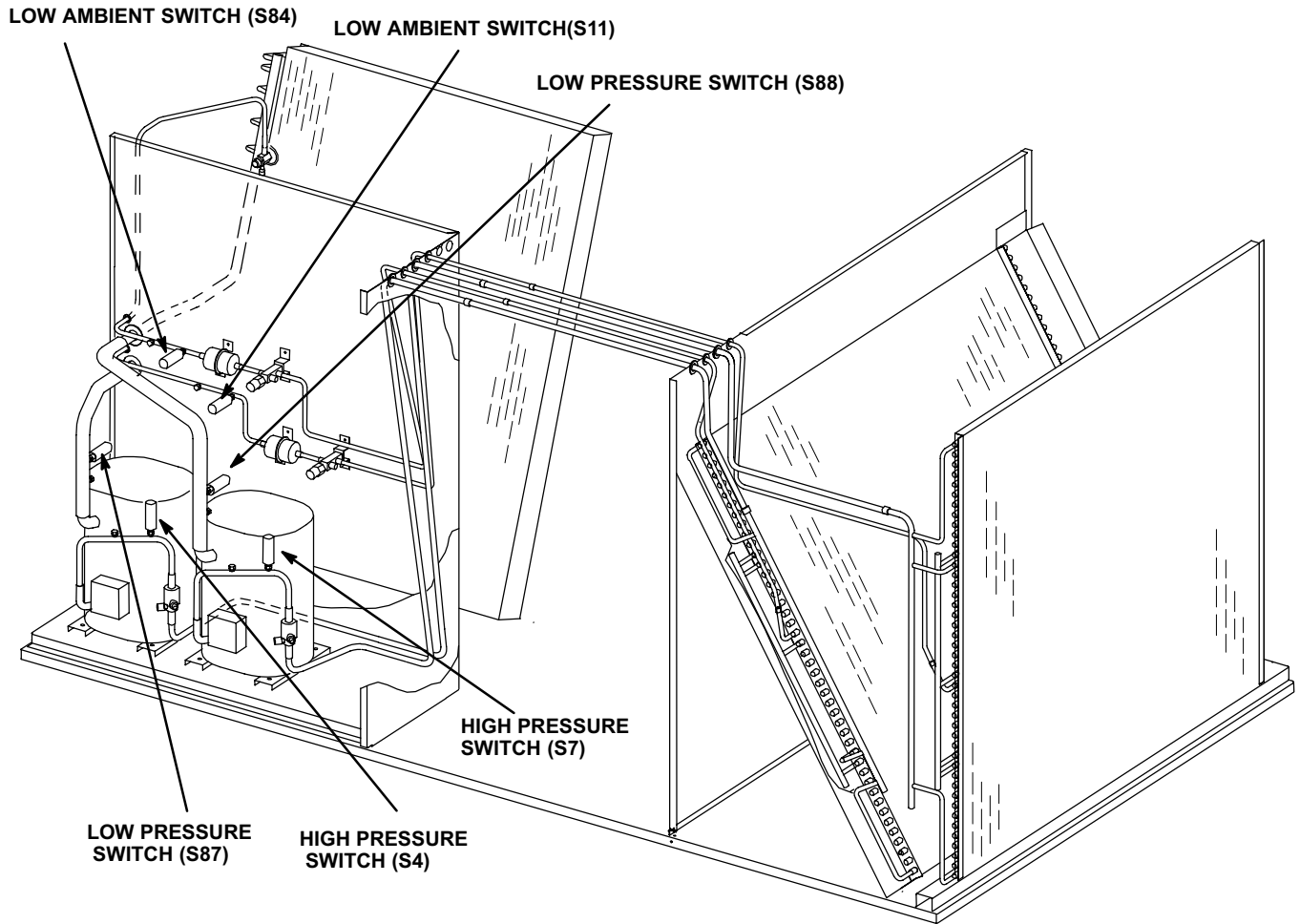

FIGURE 12

LGA/LCA PLUMBING COMPONENTS
LGA102-120 Standard Efficiency Shown



LGA102H-150H High Efficiency
150S Standard Efficiency Shown

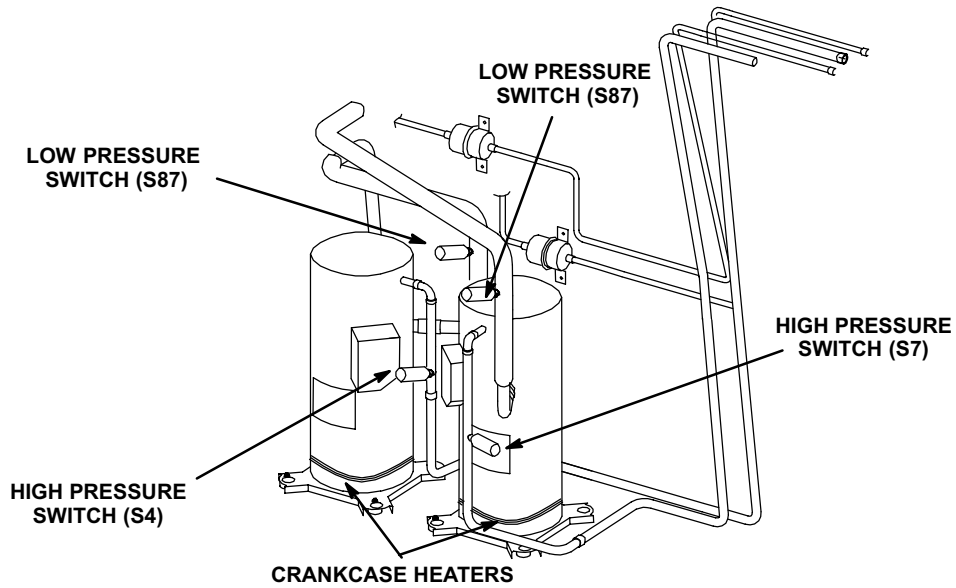
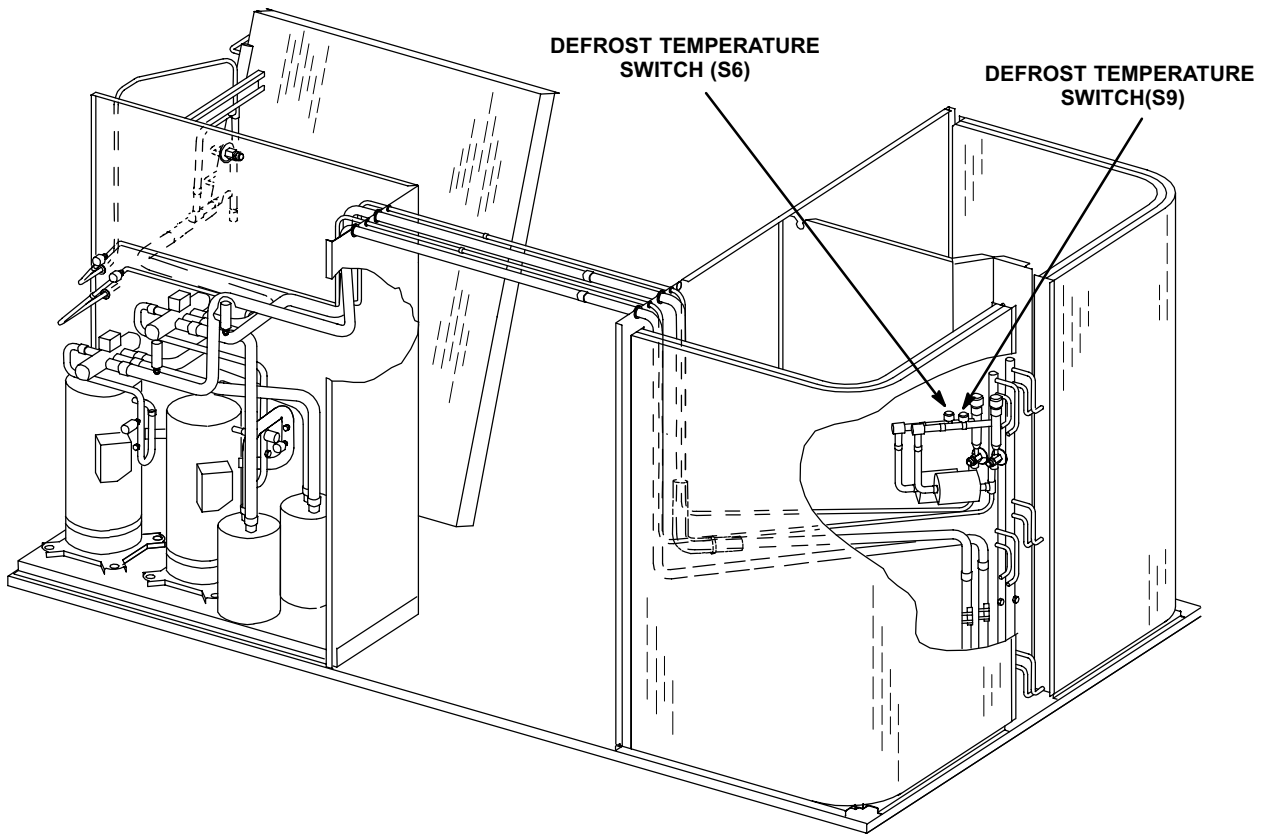

FIGURE 13

LHA090-120 PLUMBING COMPONENTS



LHA090-120 COMPRESSOR DETAIL

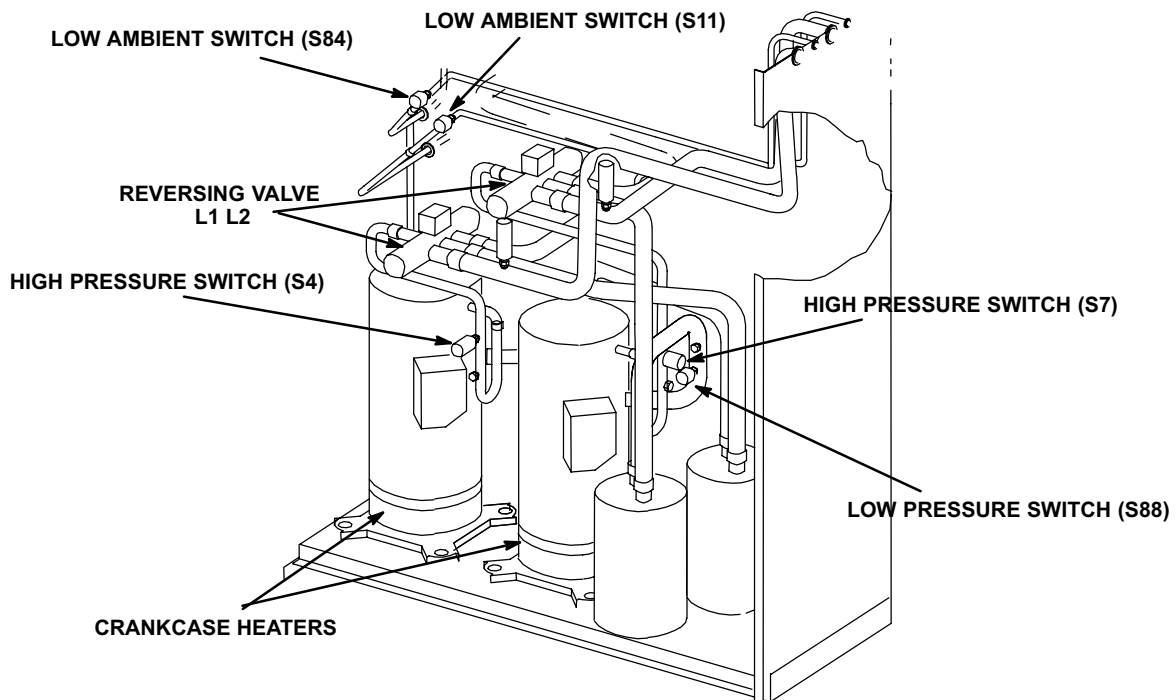

FIGURE 14

B-Cooling Components

Components described in this section may not be shared by all LGA/LCA/LHA model units. See wiring diagram for more specific component listing.

LGA/LCA/LHA units use independent cooling circuits consisting of separate compressors, condenser coils and evaporator coils. See figures 11 through 14. Units are equipped with one or two draw-through type condenser fans. All units are equipped with belt-drive blowers which draw air across the evaporator during unit operation.

Cooling may be supplemented by a factory- or field-installed economizer. The evaporator is slab type and uses a thermostatic expansion valve as the primary expansion device. Each evaporator is also equipped with enhanced fins and rifled tubing. In all units each compressor is protected by a crankcase heater, high pressure switch and low pressure switch. Additional protection is provided by low ambient switches and frezestats (on each evaporator stage).

1-Compressors B1 and B2

See table 2 for compressor type and quantity. Compressors are supplied by various manufacturers and are equipped with independent cooling circuits. Compressor electrical specifications vary by manufacturer. See compressor nameplate for specifications.

⚠ WARNING

Electrical shock hazard. Compressor must be grounded. Do not operate without protective cover over terminals. Disconnect power before removing protective cover. Discharge capacitors before servicing unit. Failure to follow these precautions could cause electrical shock resulting in injury or death.

Each compressor is energized by a corresponding compressor contactor.

NOTE-Refer to the wiring diagram section for specific unit operation.

TABLE 2

Unit	Efficiency	Compressor	Quantity
LGA/LCA088S	Standard	Reciprocating	2
LGA/LCA100S	Standard	Scroll	2
LGA/LCA088H	High	Scroll	2
LHA088S	Standard	Scroll	1
LHA090/120H	High	Scroll	2
LGA/LCA102/120H	High	Scroll	2
LGA/LCA102/120S	Standard	Reciprocating	2
LGA/LCA150S-1	Standard	Reciprocating	2
LGA/LCA150S-2	Standard	Scroll	2

2-Crankcase Heaters HR1 and HR2

All LGA/LCA units with scroll compressors and all LHA units use belly-band type crankcase heaters, while all LGA/LCA units with reciprocating compressors use insertion type heaters. Heater HR1 is used on compressor B1 and heater HR2 is used on compressor B2. Crankcase heater wattage varies by compressor manufacturer.

3-High Pressure Switches S4 and S7

The high pressure switch is an auto-reset SPST N.C. switch which opens on a pressure rise. All LGA/LCA/LHA units are equipped with this switch. Each switch is located in the compressor discharge line. S4 (first circuit) and S7 (second circuit) are wired in series with the respective compressor contactor coils.

When discharge pressure rises to 450 ± 10 psig (3103 ± 69 kPa) (indicating a problem in the system) the switch opens and the respective compressor is de-energized (the economizer can continue to operate). When discharge pressure drops to 310 ± 20 psig (2147 ± 138 kPa) the pressure switch will close. Early model units will have a discharge pressure reset point of 210 ± 20 psig (1447 ± 138 kPa)

Main control A55 has a three-strike counter before locking out. This means the control will allow three high pressure trips per one thermostat demand. The control can be reset by breaking and remaking the thermostat demand or manually resetting the control.

4-Low Ambient Switches S11 & S84

The low ambient switch is an auto-reset SPST N.O. pressure switch which allows for mechanical cooling operation at low outdoor temperatures. All LGA/LCA/LHA units are equipped with this switch. In all models a switch is located in each liquid line prior to the indoor coil section.

In LCA/LGA 102/120/150 units, S11 and S84 wired in parallel, are wired in series with outdoor fan relay K10 (compressor one). Compressor two is under control through the IMC board. In the LHA 090/120, S11 is wired in series with outdoor fan relay K10 (compressor one) and S84 is wired in series with outdoor fan relay K68 (compressor two). LHA088 units **will not** be equipped with S11 or S84.

When liquid pressure rises to 275 ± 10 psig (1896 ± 69 kPa), the switch closes and the condenser fan is energized. When discharge pressure in both refrigerant circuits drop to 150 ± 10 psig (1034 ± 69 kPa), the switch opens and the condenser fan is de-energized. This intermittent fan operation results in higher evaporating temperature allowing the system to operate without icing the evaporator coil and losing capacity.

5-Low Pressure Switches S87 and S88

The low pressure switch is an auto-reset SPST N.O. switch (held N.C. by refrigerant pressure) which opens on a pressure drop. All LGA/LCA/LHA units are equipped with this switch. The switch is located in the compressor suction line.

S87 and S88 are wired directly to the main control module A55.

The main control module A55 governs the low pressure switches by shunting the switches during start up until pressure is stabilized. After the shunt period, the control has a three-strike counter, during first thermostat demand, before the compressor is locked out. The control is reset by breaking and remaking the thermostat demand.

When suction pressure drops to 25 ± 5 psig (172 ± 34 kPa) (indicating low pressure), the switch opens and the compressor is de-energized. The switch automatically resets when pressure in the suction line rises to 55 ± 5 psig (379 ± 34 kPa), due to many causes such as refrigerant being added.

6-Service Valves (optional on LGA/LCA units)

LGA/LCA units may be equipped with service valves located in the discharge and liquid lines. The service valves are used to store liquid refrigerant in the condenser and shorten recovery time. The valves are manually operated and are also used for service operation.

7-Reversing Valve L1 and L2 (LHA units only)

A refrigerant reversing valve with a 24 volt solenoid coil is used to reverse refrigerant flow during unit operation in all LHA units. The reversing valve is connected in the vapor line of the refrigerant circuit. The reversing valve coil is energized during cooling demand and during defrost.

Reversing valve L1 is controlled by the main control module A55 in response to cooling demand or by defrost. Reversing valve L2 is controlled by heat pump module A61 in response to second stage cooling demand.

8-Accumulator (all LHA units)

All LHA units are equipped with accumulators. The purpose of the accumulator is to trap and evaporate all liquid refrigerant and prevent liquid refrigerant from entering the compressor.

9-Defrost Pressure Switch S46 and S104 (LHA only)

The defrost pressure switch S46 and S104 are auto-reset SPST N.C. pressure switches which open on a pressure rise. All LHA units are equipped with these switches. The switches are located on the suction line during heating cycle (discharge line during cooling and defrost cycle). S46 is wired to the main control board A55 and S104 is wired to heat pump control board A61.

When discharge pressure reaches 275 ± 10 psig (1896 ± 69 kPa) (indicating defrost is completed) the switch opens. The switch automatically resets when pressure in the suction line drops by 80 ± 10 psig (552 ± 69 kPa).

10-High Temperature Limit Switch S5 (LHA088 only)

S5 discharge temperature switch is wired in series with the S4 high pressure switch. S5 is a normally closed switch which opens on temperature rise. The switch will open at $221^{\circ}\text{F} \pm 9^{\circ}\text{F}$ ($105^{\circ}\text{C} \pm 5^{\circ}\text{C}$) and close at $171^{\circ}\text{F} \pm 13^{\circ}\text{F}$ ($72^{\circ}\text{C} \pm 7.2^{\circ}\text{C}$). Actual refrigerant temperature will be higher than the switch setting due to thermal contact losses. The purpose of the switch is to protect the compressor from extreme discharge temperatures during abnormal operating conditions, such as defrost with low system charge. S5 and S4 are wired together to the same IMC contact which means the IMC will not distinguish one fault from the other. **If either switch trips, the IMC will default to the S4 error codes.**

11-Defrost Temperature Switch S6 and S9 (LHA only)

Defrost thermostat switches S6 and S9 have S.P.S.T. N.O. contacts which closes on a temperature fall (initiating defrost). The switches are located on the expansion valve distributor assembly at the inlet to the outdoor coil. The switch monitors the outdoor coil suction temperature to determine when defrost is needed. When the outdoor coil suction temperature falls to $35^{\circ}\text{F} \pm 4^{\circ}\text{F}$ ($1.7^{\circ}\text{C} \pm 2.2^{\circ}\text{C}$) the switch closes (initiating defrost after minimum run time of 30, 60, or 90 minutes). When the temperature rises to $60^{\circ}\text{F} \pm 5^{\circ}\text{F}$ ($15.6^{\circ}\text{C} \pm 2.8^{\circ}\text{C}$) the switch opens.

12-Filter Drier (all units)

LGA/LCA/LHA units have a filter drier located in the liquid line of each refrigerant circuit at the exit of each condenser coil (outdoor coil in LHA units). The drier removes contaminants and moisture from the system.

13-Freezestats S49 and S50

Each unit is equipped with a low temperature switch (freezestat) located on a return bend of each evaporator coil. S49 (first circuit), S50 (second circuit), are located on the corresponding evaporator coils.

Each freezestat is wired to the main control module A55. Each freezestat is a SPST N.C. auto-reset switch which opens at $29^{\circ}\text{F} \pm 3^{\circ}\text{F}$ ($-1.7^{\circ}\text{C} \pm 1.7^{\circ}\text{C}$) on a temperature drop and closes at $58^{\circ}\text{F} \pm 4^{\circ}\text{F}$ ($14.4^{\circ}\text{C} \pm 2.2^{\circ}\text{C}$) on a temperature rise. To prevent coil icing, freezestats open during compressor operation to temporarily disable the respective compressor until the coil warms sufficiently to melt any accumulated frost.

If the freezestats are tripping frequently due to coil icing, check the unit charge, airflow and filters before allowing unit back in operation. Make sure to eliminate conditions which might promote evaporator ice buildup.

14-Condenser Fan Motors B4 and B5

See specifications section of this manual for specifications of condenser fans B4 and B5. LGA/LCA/LHA090/102/120/150 units, are equipped with two condenser fans with 1/3 hp motors. The LGA/LCA/LHA088/100 units have one condenser fan and use 1/2 hp motors. All motors are ball bearing type single-phase motors and have a three pin plug for easy motor lead removal. The fans may be removed for servicing and cleaning by removing the fan grilles.

C-Blower Compartment

The blower compartment in all LGA/LCA/LHA units is located between the evaporator coil and the condenser coil section. The blower assembly is accessed by disconnecting the blower motor and all other plugs and removing the screws in front of the blower housing. The blower pulls out as shown in figure 15.

1-Blower Wheel (all units)

All LGA/LCA/LHA090/102/120/150 units have one 15 in. x 15 in. (381 mm x 381 mm) blower wheel. All LGA/LCA/LHA088/100 units have one 12 in. x 12 in. (305 mm x 305 mm) blower wheel.

2-Indoor Blower Motor B3 (all units)

All LGA/LCA/LHA units use three-phase single-speed blower motors. CFM adjustments are made by adjusting the motor pulley (sheave) to adjust blower speed. Motors are equipped with sealed ball bearings. All motor specifications are listed in the SPECIFICATIONS section at the front of this manual. Units may be equipped with motors manufactured by various manufacturers, therefore electrical FLA and LRA specifications will vary. See unit rating plate for information specific to your unit.

OPERATION / ADJUSTMENT

Blower Operation

NOTE-The following is a generalized procedure and does not apply to all thermostat control systems.

- 1- Blower operation is dependent on the thermostat control system option that has been installed in the LGA/LCA/LHA units. Refer to operation sequence of the control system installed for detailed descriptions of blower operation.
- 2- Generally, blower operation is set at the thermostat fan switch. With the fan switch in "ON" position and the **OCP** input is "ON", the blower operates continuously. With the fan switch in "AUTO" position, the blower cycles with demand.
- 3- In most cases, the blower and entire unit will be off when the system switch is in the "OFF" position. The only exception is immediately after a heating demand when the blower control keeps the blower on until all heat is extracted from the heat exchanger.

Determining Unit Air Volume

- 1- The following measurements must be made with a dry indoor coil. Run blower without cooling demand. Air filters must be in place when measurements are taken.
- 2- With all access panels in place, measure static pressure external to unit (from supply to return).
- 3- Measure the indoor blower wheel RPM.
- 4- Refer to blower table on page 7, use static pressure and RPM readings to determine unit air volume.
- 5- The RPM can be adjusted at the motor pulley. Loosen Allen screw and turn adjustable pulley clockwise to increase RPM. Turn counterclockwise to decrease RPM. See figure 15.

Blower Belt Adjustment

Proper pulley alignment and belt tension must be maintained for maximum belt life.

NOTE-Tension new belt after 24-48 hours of operation. This will allow belts to stretch and seat in grooves.

- 1- Loosen four screws securing blower motor to sliding base. See figure 15.
- 2- *To increase belt tension -*
Turn belt tension adjusting screw to the left, or counterclockwise, to tighten the belt. This increases the distance between the blower motor and the blower housing.

To loosen belt tension -

Turn the adjusting screw to the right, or clockwise to loosen belt tension.

- 3- Tighten four screws securing blower motor to sliding base once adjustments have been made.

Blower Access

- 1- Disconnect jack/plug connector to blower motor. Also disconnect jack/plug connector heating limit switches on LGA units.
- 2- Remove screws on either side of blower assembly sliding base. See figure 15
- 3- Pull base toward outside of unit.

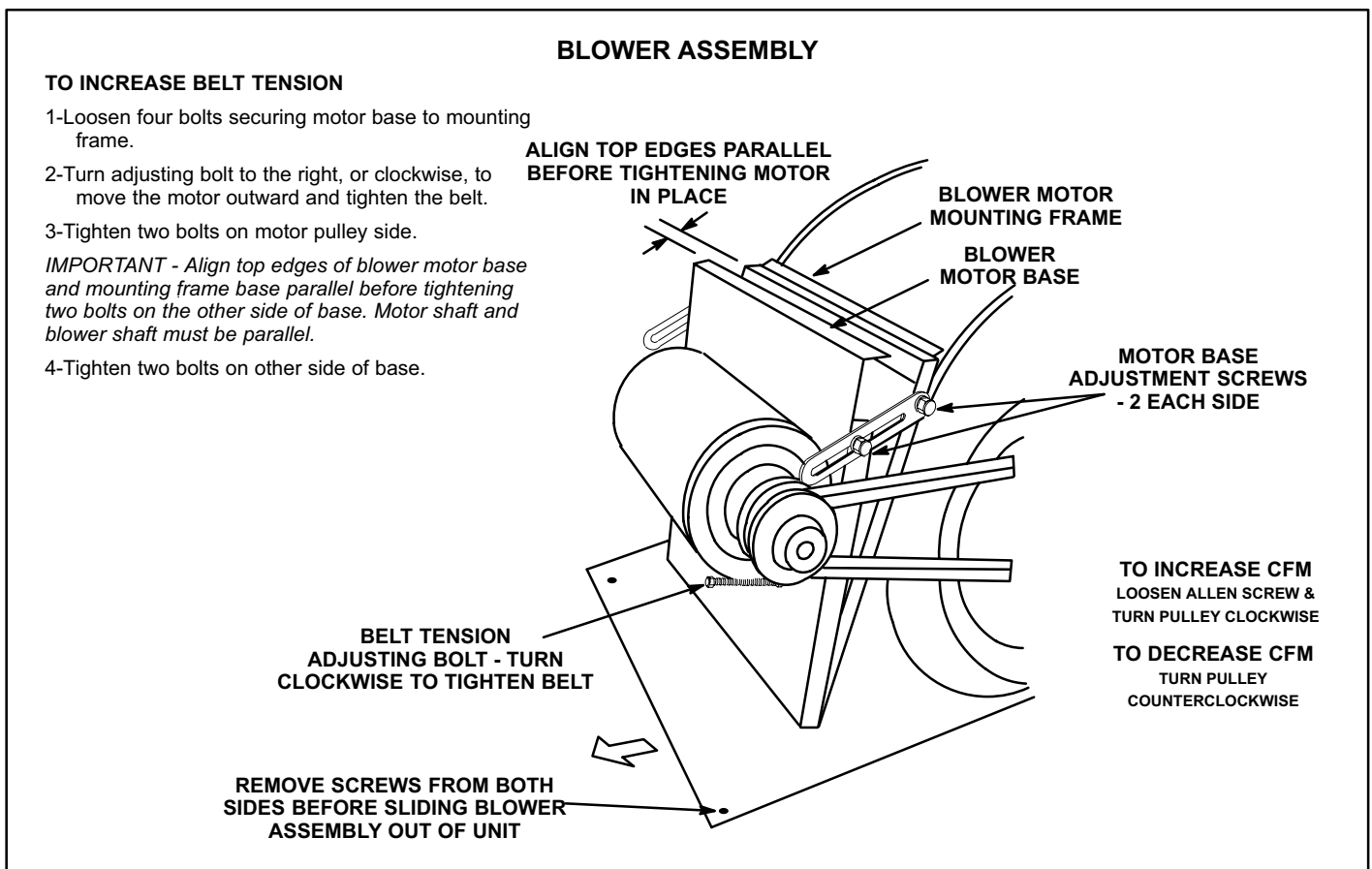

FIGURE 15

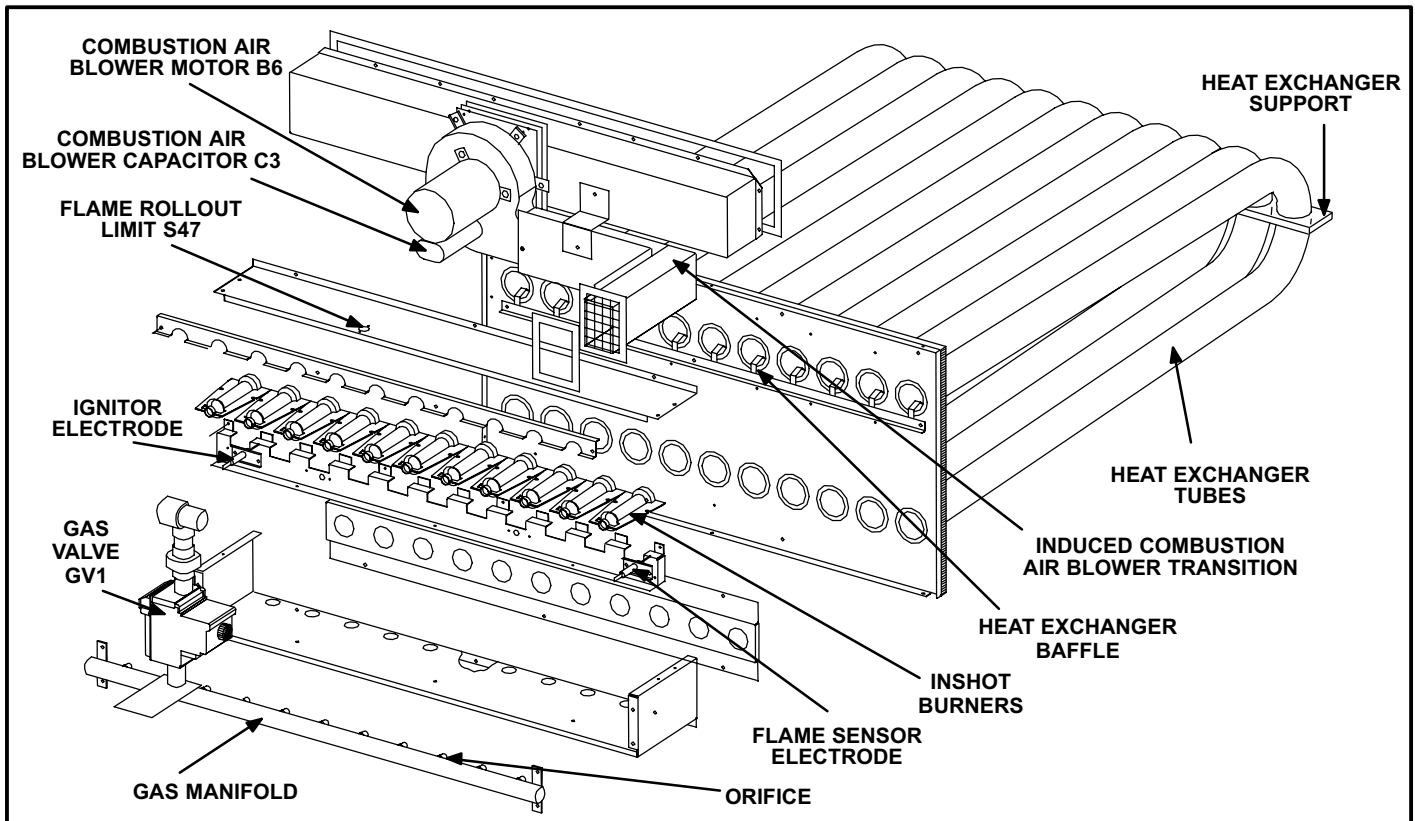

FIGURE 16

D-GAS HEAT COMPONENTS (LGA units)

LGA088/100 units are available in 125,000 BTUH (36.6 kW) (standard gas heat) or 180,000 BTUH (52.74 kW) (high heat) sizes. LGA102/120/150 units are available in 130,000 BTUH (38.1 kW) (standard gas heat) or 235,000 BTUH (68.8kW) (high gas heat) sizes.

1-Burner Ignition Control A3

The ignition control is located below the control box. Three different manufacturers' (Fenwal, Johnson Controls, and RAM) controls are used in the LGA units. All three ignition controls operate the same.

The ignition control provides three main functions: gas valve control, ignition, and flame sensing. The unit will usually ignite on the first attempt; however, the ignition attempt sequence provides three trials for ignition before locking out. The lockout time for the Johnson control is 5 minutes. The lockout time for the Ram control and Fenwall control is 1 hour. After lockout, the ignition control automatically resets and provides three more attempts at ignition. Manual reset after lockout requires breaking and remaking power to the ignition control. See figure 18 for a normal ignition sequence and figure 19 for the ignition attempt sequence with retries (nominal timings given for simplicity). Specific timings for the ignition controls are shown in figure 20.

Flame rectification sensing is used on all LGA units. Loss of flame during a heating cycle is indicated by an absence of flame signal (0 microamps). If this happens, the control will immediately restart the ignition sequence and then lock out if ignition is not gained after the third trial. See Service System Checks section for flame current measurement.

The control shuts off gas flow immediately in the event of a power failure. Upon restoration of gas and power, the control will restart the ignition sequence and continue until flame is established or system locks out.

On a heating demand, the ignition control is energized by the main control module A55. The ignition control then allows 30 seconds for the combustion air blower to vent exhaust gases from the burners. When the combustion air blower is purging the exhaust gases, the combustion air prove switch is closing proving that the combustion air blower is operating before allowing the ignition control to energize. When the combustion air prove switch is closed and the delay is over, the ignition control activates gas valve, the spark electrode and the flame sensing electrode. Sparking stops immediately after flame is sensed. The combustion air blower continues to operate throughout the heating demand. If the flame fails or if the

burners do not ignite, the ignition control will attempt to ignite the burners up to two more times. If ignition cannot be obtained after the third attempt, the control will lock out. The ignition control is not adjustable.

The RAM control is illustrated in figure 17. The four spade connections are used to connect the control to unit. Each of the four spade terminals are identified by function. The spark electrode wire connects to the spark-plug-type connector on top of the control.

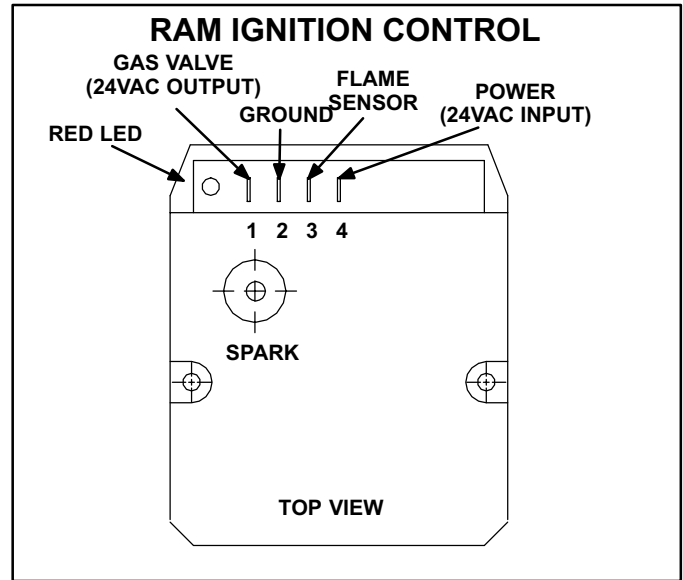

FIGURE 17

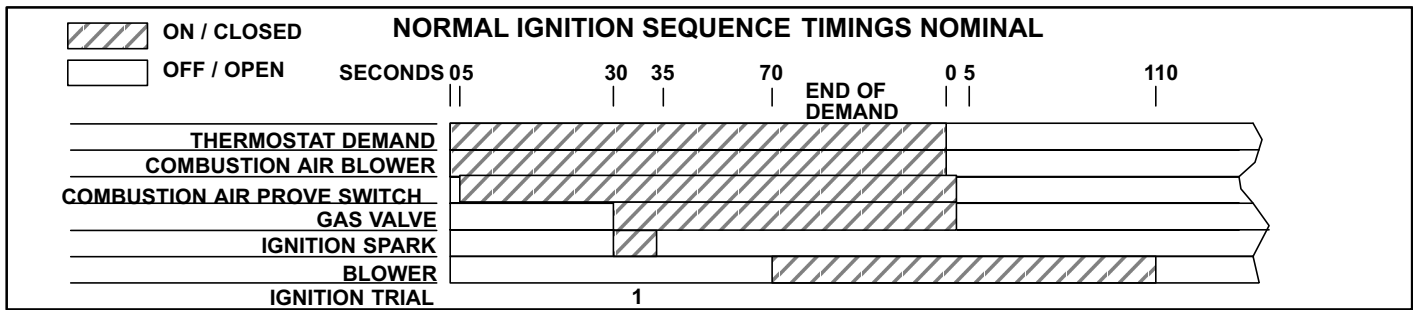

FIGURE 18

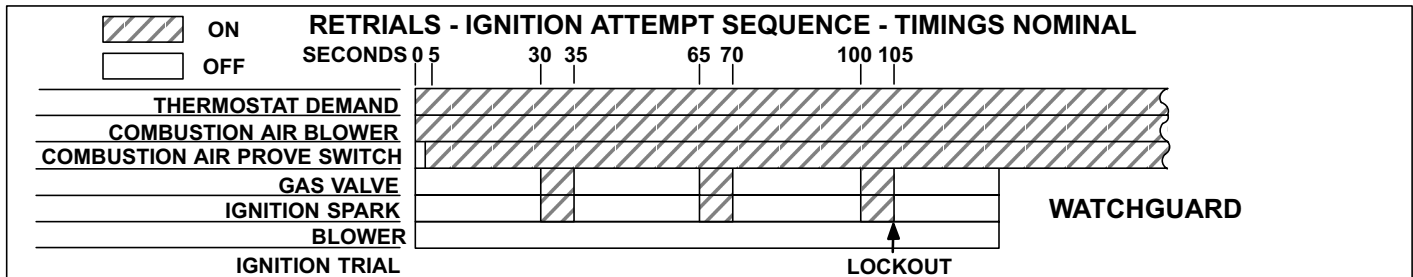

FIGURE 19

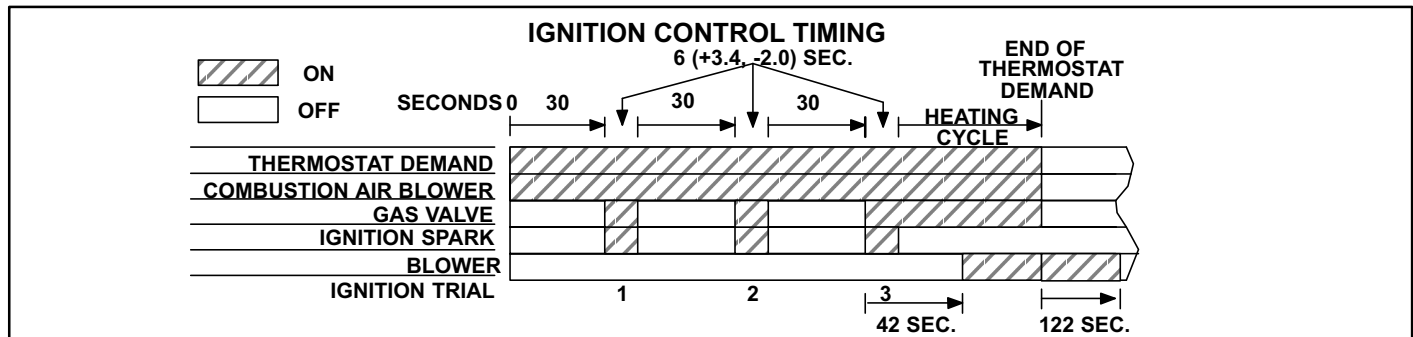

FIGURE 20

⚠ WARNING

SHOCK HAZARD. SPARK RELATED COMPONENTS CONTAIN HIGH VOLTAGE WHICH CAN CAUSE PERSONAL INJURY OR DEATH. DISCONNECT POWER BEFORE SERVICING. CONTROL IS NOT FIELD REPAIRABLE. UNSAFE OPERATION WILL RESULT. IF THE CONTROL IS INOPERABLE, SIMPLY REPLACE THE ENTIRE CONTROL.

2-Heat Exchanger (Figure 16)

The LGA units use aluminized steel inshot burners with matching tubular aluminized or optional stainless steel heat exchangers and two-stage redundant gas valve. LGA uses one eleven tube/burners for high heat and one seven tube/burners for standard heat. Each burner uses a burner venturi to mix gas and air for proper combustion. Combustion takes place at each tube entrance. As hot combustion gases are drawn upward through each tube by the combustion air blower, exhaust gases are drawn out the top and fresh air/gas mixture is drawn in at the bottom. Heat is transferred to the air stream from all surfaces of the heat exchanger tubes. The supply air blower controlled by the main control panel A55, forces air across all surfaces of the tubes to extract the heat of combustion. The shape of the tubes ensures maximum heat exchange.

The gas valve accomplishes staging by allowing more or less gas to the burners as called for by heating demand.

3-Burner Assembly (Figure 21)

The spark electrode, flame sensing electrode and gas valve are directly controlled by ignition control. Ignition control and combustion air blower is controlled by main control panel A55.

Burners

All units use inshot burners (see figure 21). Burners are factory set and do not require adjustment. A peep hole with cover is furnished in the heating access panel for flame viewing. Always operate the unit with the access panel in place. Burners can be removed individually for service. Burner maintenance and service is detailed in the SERVICE CHECKS sections of this manual.

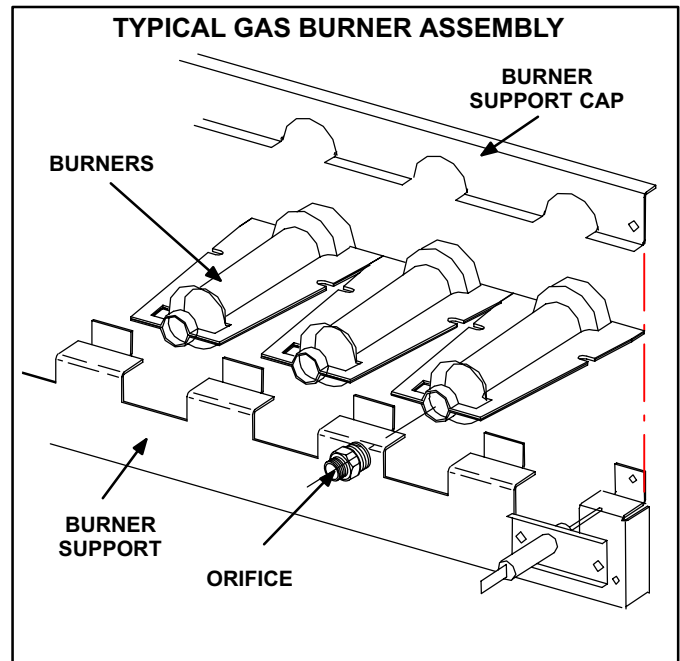

FIGURE 21

Orifice

Each burner uses an orifice which is precisely matched to the burner input. The orifice is threaded into the burner manifold. The burner is supported by the orifice and will easily slide off for service.

NOTE-Do not use thread sealing compound on the orifices. Using thread sealing compound may plug the orifices.

Each orifice and burner are sized specifically to the unit. Refer to Lennox Repair Parts Listing for correct sizing information.

4-Primary High Temperature Limit S10

S10 is the primary high temperature limit for gas heat. S10 is located on the blower deck behind the blower.

Primary limit S10 is wired to the main control panel A55 which energizes burner control (A3). Its N.C. contacts open to de-energize the ignition control when excessive temperature is reached in the blower compartment. At the same time, the N.O. contacts of S10 close energizing the blower relay coil K3 through control A55.

Limit S10 in all gas heat units is factory preset to open at $170^{\circ}\text{F} \pm 6^{\circ}\text{F}$ ($76^{\circ}\text{C} \pm 3.3^{\circ}\text{C}$) on a temperature rise and automatically reset at $140^{\circ}\text{F} \pm 7^{\circ}\text{F}$ ($60^{\circ}\text{C} \pm 3.9^{\circ}\text{C}$) on a temperature fall.

5-Flame Rollout Limit S47

Flame rollout limit S47 is a SPST N.C. high temperature limit located just above the burner air intake opening in the burner enclosure (see figure 16). S47 is wired to the main control panel A55. When S47 senses flame rollout (indicating a blockage in the combustion air passages), the flame rollout limit trips, and the ignition control immediately closes the gas valve.

Limit S47 is factory preset to open at $250^{\circ}\text{F} \pm 12^{\circ}\text{F}$ ($121.1^{\circ}\text{C} \pm 6.7^{\circ}\text{C}$) for standard heat units, and $270^{\circ}\text{F} \pm 12^{\circ}\text{F}$ ($132^{\circ}\text{C} \pm 6.7^{\circ}\text{C}$) for high heat units on a temperature rise. All flame rollout limits are manual reset.

6-Combustion Air Prove Switch S18

The combustion air prove switch S18 is a SPST N.O. pressure switch located in the vestibule area. The switch is used to monitor combustion air inducer operation. Switch S18 is wired to the main control panel A55. The switch actuates at $0.80'' \text{ W.C.} \pm 0.05'' \text{ W.C.}$ ($198.9\text{Pa} \pm 12.4 \text{ Pa}$) for standard heat units, and $1.0'' \text{ W.C.} \pm 0.05'' \text{ W.C.}$ ($248.6 \pm 0.05'' \text{ W.C.}$) for high heat units on a pressure fall. This pressure fall and switch actuation allows power to the ignition control (proves, by closing, that the combustion air inducer is operating before allowing the ignition control to energize). The combustion air prove switch is factory set and not adjustable. The switch will automatically open on a pressure rise at $0.65'' \text{ W.C.}$ negative pressure (161.6 Pa) for standard heat units and $0.85''$ (211 Pa) negative pressure for high heat units.

7-Combustion Air Inducer B6

Combustion air inducer B6 provides fresh air to the burners while clearing the combustion chamber of exhaust gases. The blower begins operating immediately upon receiving a thermostat demand and is de-energized immediately when thermostat demand is satisfied.

The combustion air inducer uses a 208/230V single-phase PSC motor and a 4.81in. x 1.25in. (122mm x 32mm) blower wheel. The motor operates at 3200RPM and is equipped with auto-reset overload protection. Blowers are supplied by various manufacturers. Ratings may vary by manufacturer. Specific blower electrical ratings can be found on the unit rating plate.

All combustion air inducer motors are sealed and cannot be oiled. The blower cannot be adjusted but can be disassembled for cleaning.

8-Combustion Air Motor Capacitor C3

The combustion air blower motor in all LGA units requires a run capacitor. Capacitor C3 is connected to combustion air blower B6. All capacitors are rated at 3 MFD and 370VAC.

9-Gas Valve GV1

Gas valve GV1 is a two-stage redundant gas valve used in all LGA units. Units are equipped with valves manufactured by White-Rodgers or Honeywell. For both valves first stage (low fire) is quick opening (on and off in less than 3 seconds). For the WhiteRodgers valve second stage is slow opening (on to high fire pressure in 40 seconds and off to low fire pressure in 30 seconds). Second stage for the Honeywell valve is quick opening and close. On a call for first stage heat (low fire), the valve is energized by the ignition control simultaneously with the spark electrode. On a call for second stage heat (high fire), the second stage operator is energized directly from A55. The WhiteRodgers valve is adjustable on high fire only. The Honeywell valve is adjustable for both high and low fire. A manual shut-off knob is provided on all valves for shut-off. Manual shut-off knob immediately closes both stages without delay. Figure 22 shows White-Rodgers gas valve components. Table 3 shows factory gas valve regulation for LGA series units.

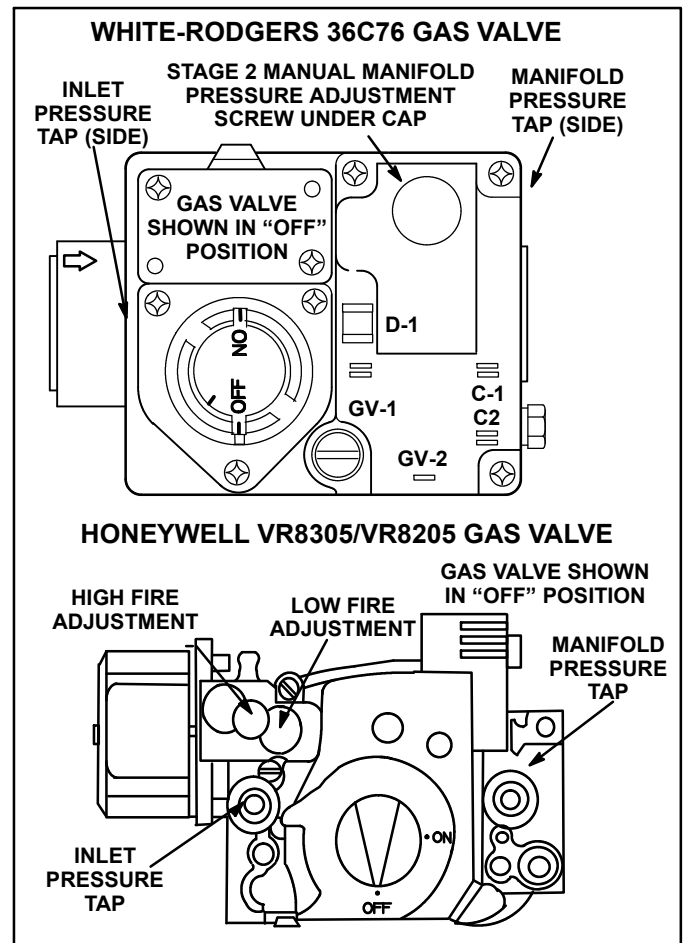

FIGURE 22

TABLE 3

GAS VALVE REGULATION FOR LGA UNITS				
Maximum Inlet Pressure	Operating Pressure (outlet) Factory Setting			
	Natural		L.P.	
	Low	High	Low	High
13.0"W.C. 3232Pa	1.6±0.2"W.C. 398±50Pa	3.7±0.3"W.C. 920±75Pa	5.5±0.3"W.C. 1368±75Pa	10.5±0.5"W.C. 2611±124Pa

10-Spark Electrodes

An electrode assembly is used for ignition spark. The electrode is mounted through holes on the left-most end of the burner support. The electrode tip protrudes into the flame envelope of the adjacent burner. The electrode assembly is fastened to burner supports and can be removed for service without removing any part of the burners.

During ignition, spark travels through the spark electrode (figure 23) and ignites the left burner. Flame travels from burner to burner until all are lit.

The spark electrode is connected to the ignition control by a 8 mm silicone-insulated stranded high voltage wire. The wire uses 1/4" (6.35 mm) female quick connect on the electrode end and female spark plug-type terminal on the ignition control end.

NOTE-IN ORDER TO MAXIMIZE SPARK ENERGY TO ELECTRODE, HIGH VOLTAGE WIRE SHOULD TOUCH UNIT CABINET AS LITTLE AS POSSIBLE.

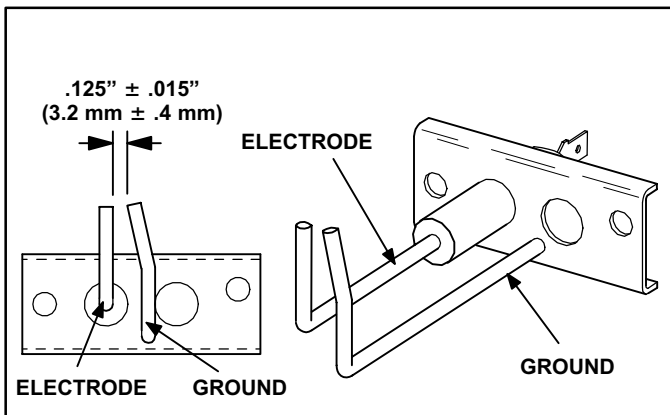

FIGURE 23

11-Flame Sensors

A flame sensor (figure 24) is located on the right side of the burner support. The sensor is mounted through a hole in the burner support and the tip protrudes into the flame envelope of the right most burner. The sensor assembly is fastened to burner supports and can be removed for service without removing any part of the burners.

When flame is sensed by the flame sensor (indicated by microamp signal through the flame) sparking stops immediately. During operation, flame is sensed by current passed along the ground electrode (located on the spark electrode), through the flame and into the sensing electrode. The ignition control allows the gas valve to stay open as long as a flame signal (current passed through the flame) is sensed.

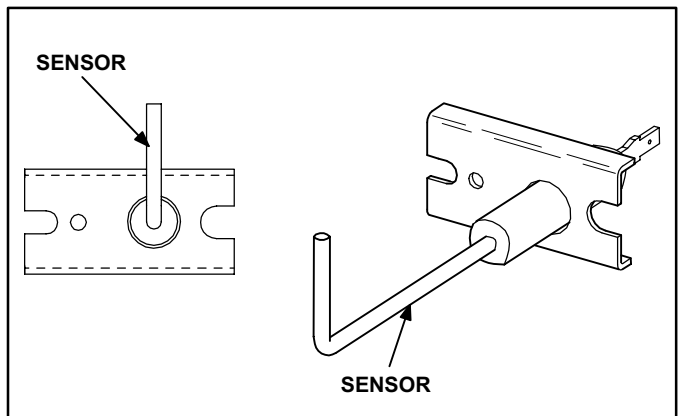

FIGURE 24

Electric Heat Data

TABLE 4

LCA088S									
kW Size Required	Electric Heat Model No. & Net Weight	No. of Steps	Volts Input	kW Input	Btuh Output	†Total Unit (with Power Exhaust Fan) & Electric Heat Minimum Circuit Ampacity			
						2 hp (1.5 kW)	3 hp (2.2 kW)		
7.5 kW	EHA100-7.5 208/230v (16L08) 460v (16L09) 575v (16L10) 31 lbs. (14 kg)	1	208	5.6	19,100	41	44		
		1	220	6.3	21,500				
		1	230	6.9	23,600				
		1	240	7.5	25,600				
				1	440	6.9	21,500	23	24
				1	460	6.9	23,600		
				1	480	7.5	25,600		
				1	550	6.3	21,500	18	20
				1	575	6.9	23,600		
				1	600	7.5	25,600		
15 kW	EHA100-15 208/230v (16L11) 460v (16L12) 575v (16L13) 31 lbs. (14 kg)	1	208	11.3	38,600	58	62		
		1	220	12.6	43,000				
		1	230	13.8	47,100				
		1	240	15.0	51,200				
				1	440	12.6	43,000	29	31
				1	460	13.8	47,100		
				1	480	15.0	51,200		
				1	550	12.6	43,000	23	25
				1	575	13.8	47,100		
				1	600	15.0	51,200		
22.5 kW	EHA100-22.5 208/230v (32L95) 460v (32L96) 575v (32L97) 38 lbs. (17 kg)	‡2	208	16.9	57,700	73	77		
		‡2	220	18.9	64,500				
		‡2	230	20.7	70,700				
		‡2	240	22.5	76,800				
				‡2	440	18.9	64,500	82	86
				‡2	460	20.7	70,700		
				‡2	480	22.5	76,800		
				‡2	550	18.9	64,500	41	43
				‡2	575	20.7	70,700		
				‡2	600	22.5	76,800		
30 kW	EHA100-30 208/230v (16L14) 460v (16L15) 575v (16L16) 38 lbs. (17 kg)	‡2	208	22.5	76,800	91	95		
		‡2	220	25.2	86,000				
		‡2	230	27.5	93,900				
		‡2	240	30.0	102,400				
				‡2	440	25.2	86,000	103	107
				‡2	460	27.5	93,900		
				‡2	480	30.0	102,400		
				‡2	550	25.2	86,000	51	53
				‡2	460	27.5	93,900		
				‡2	480	30.0	102,400		
		‡2	575	27.5	93,900	41	43		
		‡2	600	30.0	102,400				
		‡2	600	30.0	102,400				
45 kW	EHA100-45 208/230v (16L17) 460v (16L18) 575v (16L19) 42 lbs. (19 kg)	‡2	208	33.8	115,300	130	134		
		‡2	220	37.8	129,000				
		‡2	230	41.3	141,000				
		‡2	240	45.0	153,600				
				‡2	440	37.8	129,000	148	152
				‡2	460	41.3	141,000		
				‡2	480	45.0	153,600		
				‡2	550	37.8	129,000	74	76
				‡2	460	41.3	141,000		
				‡2	480	45.0	153,600		
		‡2	575	41.3	141,000	59	61		
		‡2	600	45.0	153,600				
		‡2	600	45.0	153,600				

NOTE - (H) indicates high efficiency units. (S) indicates standard efficiency units.
 †Refer to National or Canadian Electrical Code manual to determine wire, fuse and disconnect size requirements. Use wires suitable for at least 167°F (75°C).
 ‡May be used with two stage control.
 NOTE — Fuse block must be ordered extra. Factory installed heaters will have the fuse block factory installed. Fuse block must be installed in unit with field installed heaters. Also requires LTB2 Terminal Block.

TABLE 5

LCA088H									
kW Size Required	Electric Heat Model No. & Net Weight	No. of Steps	Volts Input	kW Input	Btuh Output	†Total Unit (with Power Exhaust Fan) & Electric Heat Minimum Circuit Ampacity			
						2 hp (1.5 kW)	3 hp (2.2 kW)		
7.5 kW	EHA100-7.5 208/230v (16L08) 460v (16L09) 575v (16L10) 31 lbs. (14 kg)	1	208	5.6	19,100	41	44		
		1	220	6.3	21,500				
		1	230	6.9	23,600				
		1	240	7.5	25,600				
				1	440	6.9	21,500	21	20
				1	460	6.9	23,600		
				1	480	7.5	25,600		
				1	550	6.3	21,500	17	18
				1	575	6.9	23,600		
				1	600	7.5	25,600		
15 kW	EHA100-15 208/230v (16L11) 460v (16L12) 575v (16L13) 31 lbs. (14 kg)	1	208	11.3	38,600	52	56		
		1	220	12.6	43,000				
		1	230	13.8	47,100				
		1	240	15.0	51,200				
				1	440	12.6	43,000	58	62
				1	460	13.8	47,100		
				1	480	15.0	51,200		
				1	550	12.6	43,000	29	31
				1	460	13.8	47,100		
				1	480	15.0	51,200		
		1	575	13.8	47,100	23	25		
		1	600	15.0	51,200				
		1	600	15.0	51,200				
22.5 kW	EHA100-22.5 208/230v (32L95) 460v (32L96) 575v (32L97) 38 lbs. (17 kg)	‡2	208	16.9	57,700	73	77		
		‡2	220	18.9	64,500				
		‡2	230	20.7	70,700				
		‡2	240	22.5	76,800				
				‡2	440	18.9	64,500	82	86
				‡2	460	20.7	70,700		
				‡2	480	22.5	76,800		
				‡2	550	18.9	64,500	41	43
				‡2	575	20.7	70,700		
				‡2	600	22.5	76,800		
30 kW	EHA100-30 208/230v (16L14) 460v (16L15) 575v (16L16) 38 lbs. (17 kg)	‡2	208	22.5	76,800	91	95		
		‡2	220	25.2	86,000				
		‡2	230	27.5	93,900				
		‡2	240	30.0	102,400				
				‡2	440	25.2	86,000	103	107
				‡2	460	27.5	93,900		
				‡2	480	30.0	102,400		
				‡2	550	25.2	86,000	51	53
				‡2	460	27.5	93,900		
				‡2	480	30.0	102,400		
		‡2	575	27.5	93,900	41	43		
		‡2	600	30.0	102,400				
		‡2	600	30.0	102,400				
45 kW	EHA100-45 208/230v (16L17) 460v (16L18) 575v (16L19) 42 lbs. (19 kg)	‡2	208	33.8	115,300	130	134		
		‡2	220	37.8	129,000				
		‡2	230	41.3	141,000				
		‡2	240	45.0	153,600				
				‡2	440	37.8	129,000	148	152
				‡2	460	41.3	141,000		
				‡2	480	45.0	153,600		
				‡2	550	37.8	129,000	74	76
				‡2	460	41.3	141,000		
				‡2	480	45.0	153,600		
		‡2	575	41.3	141,000	59	61		
		‡2	600	45.0	153,600				
		‡2	600	45.0	153,600				

NOTE - (H) indicates high efficiency units. (S) indicates standard efficiency units.
 †Refer to National or Canadian Electrical Code manual to determine wire, fuse and disconnect size requirements. Use wires suitable for at least 167°F (75°C).
 ‡May be used with two stage control.
 NOTE — Fuse block must be ordered extra. Factory installed heaters will have the fuse block factory installed. Fuse block must be installed in unit with field installed heaters. Also requires LTB2 Terminal Block.

TABLE 6

LCA100S								
kW Size Required	Electric Heat Model No. & Net Weight	No. of Steps	Volts Input	kW Input	Btuh Output	†Total Unit (with Power Exhaust Fan) & Electric Heat Minimum Circuit Ampacity		
						2 hp (1.5 kW)	3 hp (2.2 kW)	
7.5 kW	EHA100-7.5 208/230v (16L08) 460v (16L09) 575v (16L10) 31 lbs. (14 kg)	1	208	5.6	19,100	44	47	
		1	220	6.3	21,500			
		1	230	6.9	23,600			
		1	240	7.5	25,600			
		1	440	6.9	21,500	22	23	
		1	460	6.9	23,600			
		1	480	7.5	25,600			
		1	550	6.3	21,500	17	18	
		1	575	6.9	23,600			
		1	600	7.5	25,600			
15 kW	EHA100-15 208/230v (16L11) 460v (16L12) 575v (16L13) 31 lbs. (14 kg)	1	208	11.3	38,600	58	62	
		1	220	12.6	43,000			
		1	230	13.8	47,100			
		1	240	15.0	51,200			
		1	440	12.6	43,000	29	31	
		1	460	13.8	47,100			
		1	480	15.0	51,200			
		1	550	12.6	43,000	23	25	
		1	575	13.8	47,100			
		1	600	15.0	51,200			
22.5 kW	EHA100-22.5 208/230v (32L95) 460v (32L96) 575v (32L97) 38 lbs. (17 kg)	‡2	208	16.9	57,700	73	77	
		‡2	220	18.9	64,500			
		‡2	230	20.7	70,700			
		‡2	240	22.5	76,800			
		‡2	440	18.9	64,500	82	86	
		‡2	460	20.7	70,700			
		‡2	480	22.5	76,800			
		‡2	550	18.9	64,500	41	43	
		‡2	575	20.7	70,700			
		‡2	600	22.5	76,800			
30 kW	EHA100-30 208/230v (16L14) 460v (16L15) 575v (16L16) 38 lbs. (17 kg)	‡2	208	22.5	76,800	91	95	
		‡2	220	25.2	86,000			
		‡2	230	27.5	93,900			
		‡2	240	30.0	102,400			
		‡2	440	25.2	86,000	103	107	
		‡2	460	27.5	93,900			
		‡2	480	30.0	102,400			
		‡2	550	25.2	86,000	51	53	
		‡2	575	27.5	93,900			
		‡2	600	30.0	102,400			
45 kW	EHA100-45 208/230v (16L17) 460v (16L18) 575v (16L19) 42 lbs. (19 kg)	‡2	208	33.8	115,300	130	133	
		‡2	220	37.8	129,000			
		‡2	230	41.3	141,000			
		‡2	240	45.0	153,600			
		‡2	440	37.8	129,000	148	152	
		‡2	460	41.3	141,000			
		‡2	480	45.0	153,600			
		‡2	550	37.8	129,000	74	76	
		‡2	575	41.3	141,000			
		‡2	600	45.0	153,600			
59	59	61	‡2	208	33.8	115,300	130	133
			‡2	220	37.8	129,000		
			‡2	230	41.3	141,000		
			‡2	240	45.0	153,600		
			‡2	440	37.8	129,000	148	152
			‡2	460	41.3	141,000		
			‡2	480	45.0	153,600		
			‡2	550	37.8	129,000	74	76
			‡2	575	41.3	141,000		
			‡2	600	45.0	153,600		

NOTE - (H) indicates high efficiency units. (S) indicates standard efficiency units.
 †Refer to National or Canadian Electrical Code manual to determine wire, fuse and disconnect size requirements. Use wires suitable for at least 167°F (75°C).
 ‡May be used with two stage control.
 NOTE — Fuse block must be ordered extra. Factory installed heaters will have the fuse block factory installed. Fuse block must be installed in unit with field installed heaters. Also requires LTB2 Terminal Block.

TABLE 7

LCA102								
kW Size Required	Electric Heat Model No. & Net Weight	No. of Steps	Volts Input	kW Input	Btuh Output	*Total Unit (with Power Exhaust Fan) & Electric Heat Minimum Circuit Ampacity		
						2 hp (1.5 kW)	3 hp (2.2 kW)	5 hp (3.7 kW)
7.5 kW	EHA102-7.5 208/230v (99J01) 460v (99J02) 575v (99J03) 31 lbs. (14 kg)	1	208	5.6	19,100	45 (H)/ 46 (S)	48 (H)/ 50 (S)	55 (H)/ 56 (S)
		1	220	6.3	21,500			
		1	230	6.9	23,600			
		1	240	7.5	25,600			
		1	440	6.9	21,500	24 (H)/ 25 (S)	25 (H)/ 26 (S)	28 (H)/ 29 (S)
		1	460	6.9	23,600			
		1	480	7.5	25,600			
		1	550	6.3	21,500	19	20	22 (H)/ 23 (S)
		1	575	6.9	23,600			
		1	600	7.5	25,600			
15 kW	EHA150-15 208/230v (99J04) 460v (99J05) 575v (99J06) 31 lbs. (14 kg)	1	208	11.3	38,600	51	55	63
		1	220	12.6	43,000	57	61	69
		1	230	13.8	47,100			
		1	240	15.0	51,200			
		1	440	12.6	43,000			
		1	460	13.8	47,100	28	30	34
		1	480	15.0	51,200			
		1	550	12.6	43,000			
		1	575	13.8	47,100	23	24	27
		1	600	15.0	51,200			
22.5 kW	EHA360-22.5 208/230v (99J28) 460v (99J29) 575v (99J30) 38 lbs. (17 kg)	**2	208	16.9	57,700			
		**2	220	18.9	64,500	82	86	94
		**2	230	20.7	70,700			
		**2	240	22.5	76,800			
		**2	440	18.9	64,500			
		**2	460	20.7	70,700	41	43	46
		**2	480	22.5	76,800			
		**2	550	18.9	64,500			
		**2	575	20.7	70,700	33	34	37
		**2	600	22.5	76,800			
30 kW	EHA150-30 208/230v (99J07) 460v (99J08) 575v (99J09) 38 lbs. (17 kg)	**2	208	22.5	76,800			
		**2	220	25.2	86,000	103	106	114
		**2	230	27.5	93,900			
		**2	240	30.0	102,400			
		**2	440	25.2	86,000			
		**2	460	27.5	93,900	51	53	56
		**2	480	30.0	102,400			
		**2	550	25.2	86,000			
		**2	575	27.5	93,900	41	42	45
		**2	600	30.0	102,400			
45 kW	EHA150-45 208/230v (99J10) 460v (99J11) 575v (99J12) 42 lbs. (19 kg)	**2	208	33.8	115,300			
		**2	220	37.8	129,000	148	151	159
		**2	230	41.3	141,000			
		**2	240	45.0	153,600			
		**2	440	37.8	129,000			
		**2	460	41.3	141,000	74	75	79
		**2	480	45.0	153,600			
		**2	550	37.8	129,000			
		**2	575	41.3	141,000	59	60	63
		**2	600	45.0	153,600			

NOTE - (H) indicates high efficiency units. (S) indicates standard efficiency units.
 *Refer to National or Canadian Electrical Code manual to determine wire, fuse and disconnect size requirements. Use wires suitable for at least 167°F (75°C).
 **May be used with two stage control.
 NOTE — Fuse block must be ordered extra. Factory installed heaters will have the fuse block factory installed. Fuse block must be installed in unit with field installed heaters. Also requires LTB2 Terminal Block.

TABLE 8

LCA120									
kW Size Required	Electric Heat Model No. & Net Weight	No. of Steps	Volts Input	kW Input	Btuh Output	*Total Unit (with Power Exhaust Fan) & Electric Heat Minimum Circuit Ampacity			
						2 hp (1.5 kW)	3 hp (2.2 kW)	5 hp (3.7 kW)	
15 kW	EHA150-15 208/230v (99J04) 460v (99J05) 575v (99J06) 31 lbs. (14 kg)	1	208	11.3	38,600	54 (H) 52 (S)	57 (H) 55 (S)	63	
		1	220	12.6	43,000				
		1	230	13.8	47,100	57	61	69	
		1	240	15.0	51,200				
		1	440	12.6	43,000				
		1	460	13.8	47,100	28	30	34	
		1	480	15.0	51,200				
		1	550	12.6	43,000				
		1	575	13.8	47,100	23	24	27	
		1	600	15.0	51,200				
22.5 kW	EHA360-22.5 208/230v (99J28) 460v (99J29) 575v (99J30) 38 lbs. (17 kg)	**2	208	16.9	57,700	73	77	85	
		**2	220	18.9	64,500				
		**2	230	20.7	70,700	82	86	94	
		**2	240	22.5	76,800				
		**2	440	18.9	64,500				
		**2	460	20.7	70,700	41	43	46	
		**2	480	22.5	76,800				
		**2	550	18.9	64,500				
		**2	575	20.7	70,700	33	34	37	
		**2	600	22.5	76,800				
30 kW	EHA150-30 208/230v (99J07) 460v (99J08) 575v (99J09) 38 lbs. (17 kg)	**2	208	22.5	76,800	91	94	102	
		**2	220	25.2	86,000				
		**2	230	27.5	93,900	103	106	114	
		**2	240	30.0	102,400				
		**2	440	25.2	86,000				
		**2	460	27.5	93,900	51	53	56	
		**2	480	30.0	102,400				
		**2	550	25.2	86,000				
		**2	575	27.5	93,900	41	42	45	
		**2	600	30.0	102,400				
45 kW	EHA150-45 208/230v (99J10) 460v (99J11) 575v (99J12) 42 lbs. (19 kg)	**2	208	33.8	115,300	130	134	141	
		**2	220	37.8	129,000				
		**2	230	41.3	141,000	148	151	159	
		**2	240	45.0	153,600				
		**2	440	37.8	129,000				
		**2	460	41.3	141,000	74	75	79	
		**2	480	45.0	153,600				
		**2	550	37.8	129,000				
		**2	575	41.3	141,000	59	60	63	
		**2	600	45.0	153,600				
60 kW	EHA150-60 208/230v (99J13) 460v (99J14) 575v (99J15) 49 lbs. (22 kg)	**2	208	45.0	153,600	138	141	149	
		**2	220	50.4	172,000				
		**2	230	55.1	188,000	157	160	168	
		**2	240	60.0	204,800				
		**2	440	50.4	172,000				
		**2	460	55.1	188,000	78	80	83	
		**2	480	60.0	204,800				
		**2	550	50.4	172,000				
		**2	575	55.1	188,000	62	64	67	
		**2	600	60.0	204,800				

NOTE - (H) indicates high efficiency units. (S) indicates standard efficiency units.
 *Refer to National or Canadian Electrical Code manual to determine wire, fuse and disconnect size requirements. Use wires suitable for at least 167°F (75°C).
 **May be used with two stage control.
 NOTE — Fuse block must be ordered extra. Factory installed heaters will have the fuse block factory installed. Fuse block must be installed in unit with field installed heaters. Also requires LTB2 Terminal Block.

TABLE 9

LCA150									
kW Size Required	Electric Heat Model No. & Net Weight	No. of Steps	Volts Input	kW Input	Btuh Output	*Total Unit (with Power Exhaust Fan) & Electric Heat Minimum Circuit Ampacity			
						2 hp (1.5 kW)	3 hp (2.2 kW)	5 hp (3.7 kW)	
15 kW	EHA150-15 208/230v (99J04) 460v (99J05) 575v (99J06) 31 lbs. (14 kg)	1	208	11.3	38,600				
		1	220	12.6	43,000				
		1	230	13.8	47,100	57	60	66	
		1	240	15.0	51,200				
		1	440	12.6	43,000				
		1	460	13.8	47,100	28	29	32	
		1	480	15.0	51,200				
		1	550	12.6	43,000				
		1	575	13.8	47,100	23	24	26	
		1	600	15.0	51,200				
22.5 kW	EHA360-22.5 208/230v (99J28) 460v (99J29) 575v (99J30) 38 lbs. (17 kg)	**2	208	16.9	57,700	73	77	85	
		**2	220	18.9	64,500				
		**2	230	20.7	70,700	82	86	94	
		**2	240	22.5	76,800				
		**2	440	18.9	64,500				
		**2	460	20.7	70,700	41	43	46	
		**2	480	22.5	76,800				
		**2	550	18.9	64,500				
		**2	575	20.7	70,700	33	34	37	
		**2	600	22.5	76,800				
30 kW	EHA150-30 208/230v (99J07) 460v (99J08) 575v (99J09) 38 lbs. (17 kg)	**2	208	22.5	76,800	91	95	102	
		**2	220	25.2	86,000				
		**2	230	27.5	93,900	103	106	114	
		**2	240	30.0	102,400				
		**2	440	25.2	86,000				
		**2	460	27.5	93,900	51	53	56	
		**2	480	30.0	102,400				
		**2	550	25.2	86,000				
		**2	575	27.5	93,900	41	42	45	
		**2	600	30.0	102,400				
45 kW	EHA150-45 208/230v (99J10) 460v (99J11) 575v (99J12) 42 lbs. (19 kg)	**2	208	33.8	115,300	130	133	141	
		**2	220	37.8	129,000				
		**2	230	41.3	141,000	148	151	159	
		**2	240	45.0	153,600				
		**2	440	37.8	129,000				
		**2	460	41.3	141,000	74	75	78	
		**2	480	45.0	153,600				
		**2	550	37.8	129,000				
		**2	575	41.3	141,000	59	61	63	
		**2	600	45.0	153,600				
60 kW	EHA150-60 208/230v (99J13) 460v (99J14) 575v (99J15) 49 lbs. (22 kg)	**2	208	45.0	153,600	138	141	149	
		**2	220	50.4	172,000				
		**2	230	55.1	188,000	157	161	168	
		**2	240	60.0	204,800				
		**2	440	50.4	172,000				
		**2	460	55.1	188,000	78	80	83	
		**2	480	60.0	204,800				
		**2	550	50.4	172,000				
		**2	575	55.1	188,000	62	64	67	
		**2	600	60.0	204,800				

*Refer to National or Canadian Electrical Code manual to determine wire, fuse and disconnect size requirements. Use wires suitable for at least 167°F (75°C).
 **May be used with two stage control.
 NOTE — Fuse block must be ordered extra. Factory installed heaters will have the fuse block factory installed. Fuse block must be installed in unit with field installed heaters. Also requires LTB2 Terminal Block.

TABLE 10

LHA088S							
kW Size Required	Electric Heat Model No. & Net Weight	No. of Steps	Volts Input	kW Input	Btuh Output	†Total Unit (with Power Exhaust Fan) & Electric Heat Minimum Circuit Ampacity	
						2 hp (1.5 kW)	3 hp (2.2 kW)
7.5 kW	EHA100-7.5 208/230v (16L08) 460v (16L09) 575v (16L10) 31 lbs. (14 kg)	1	208	5.6	19,100	72	75
		1	220	6.3	21,500		
		1	230	6.9	23,600		
		1	240	7.5	25,600		
		1	440	6.9	21,500	36	38
		1	460	6.9	23,600		
		1	480	7.5	25,600	28	29
		1	550	6.3	21,500		
		1	575	6.9	23,600		
		1	600	7.5	25,600		
15 kW	EHA100-15 208/230v (16L11) 460v (16L12) 575v (16L13) 31 lbs. (14 kg)	1	208	11.3	38,600	95	98
		1	220	12.6	43,000		
		1	230	13.8	47,100		
		1	240	15.0	51,200		
		1	440	12.6	43,000	48	49
		1	460	13.8	47,100		
		1	480	15.0	51,200	37	39
		1	550	12.6	43,000		
		1	575	13.8	47,100		
		1	600	15.0	51,200		
22.5 kW	EHA100-22.5 208/230v (32L95) 460v (32L96) 575v (32L97) 38 lbs. (17 kg)	‡2	208	16.9	57,700	108	112
		‡2	220	18.9	64,500	117	121
		‡2	230	20.7	70,700		
		‡2	240	22.5	76,800		
		‡2	440	18.9	64,500		
		‡2	460	20.7	70,700	59	61
		‡2	480	22.5	76,800		
		‡2	550	18.9	64,500	47	48
		‡2	575	20.7	70,700		
		‡2	600	22.5	76,800		
‡2	208	22.5	76,800				
30 kW	EHA100-30 208/230v (16L14) 460v (16L15) 575v (16L16) 38 lbs. (17 kg)	‡2	208	22.5	76,800	128	131
		‡2	220	25.2	86,000	140	143
		‡2	230	27.5	93,900		
		‡2	240	30.0	102,400		
		‡2	440	25.2	86,000		
		‡2	460	27.5	93,900	70	72
		‡2	480	30.0	102,400		
		‡2	550	25.2	86,000	55	56
		‡2	575	27.5	93,900		
		‡2	600	30.0	102,400		
‡2	208	22.5	76,800				
45 kW	EHA100-45 208/230v (16L17) 460v (16L18) 575v (16L19) 42 lbs. (19 kg)	‡2	208	33.8	115,300	167	170
		‡2	220	37.8	129,000	185	188
		‡2	230	41.3	141,000		
		‡2	240	45.0	153,600		
		‡2	440	37.8	129,000		
		‡2	460	41.3	141,000	93	94
		‡2	480	45.0	153,600		
		‡2	550	37.8	129,000	73	74
		‡2	575	41.3	141,000		
		‡2	600	45.0	153,600		
‡2	208	22.5	76,800				

NOTE - (H) indicates high efficiency units. (S) indicates standard efficiency units.
 †Refer to National or Canadian Electrical Code manual to determine wire, fuse and disconnect size requirements. Use wires suitable for at least 167°F (75°C).
 ‡May be used with two stage control.
 NOTE — Fuse block must be ordered extra. Factory installed heaters will have the fuse block factory installed. Fuse block must be installed in unit with field installed heaters. Also requires LTB2 Terminal Block.

TABLE 11

LHA120								
kW Size Required	Electric Heat Model No. (see footnote) & Net Weight	No. of Steps	Volts Input	kW Input	Btuh Output	*Total Unit (with Power Exhaust Fan) & Electric Heat Minimum Circuit Ampacity		
						2 hp (1.5 kW)	3 hp (2.2 kW)	5 hp (3.7 kW)
15 kW	EHA150-15 208/230v (99J04) 460v (99J05) 575v (99J06) 31 lbs. (14 kg)	1	208	11.3	38,600	93	96	102
		1	220	12.6	43,000	99	102	108
		1	230	13.8	47,100			
		1	240	15.0	51,200			
		1	440	12.6	43,000			
		1	460	13.8	47,100	50	51	54
		1	480	15.0	51,200			
		1	550	12.6	43,000	40	41	43
		1	575	13.8	47,100			
		1	600	15.0	51,200			
		1	208	16.9	57,700			
		22.5 kW	EHA360-22.5 208/230v (99J28) 460v (99J29) 575v (99J30) 38 lbs. (17 kg)	**2	208	16.9	57,700	113
**2	220			18.9	64,500	122	125	131
**2	230			20.7	70,700			
**2	240			22.5	76,800			
**2	440			18.9	64,500			
**2	460			20.7	70,700	61	63	65
**2	480			22.5	76,800			
**2	550			18.9	64,500	50	51	53
**2	575			20.7	70,700			
**2	600			22.5	76,800			
**2	208	22.5	76,800					
30 kW	EHA150-30 208/230v (99J07) 460v (99J08) 575v (99J09) 38 lbs. (17 kg)	**2	208	22.5	76,800	132	135	141
		**2	220	25.2	86,000	144	147	153
		**2	230	27.5	93,900			
		**2	240	30.0	102,400			
		**2	440	25.2	86,000			
		**2	460	27.5	93,900	72	74	77
		**2	480	30.0	102,400			
		**2	550	25.2	86,000	58	59	61
		**2	575	27.5	93,900			
		**2	600	30.0	102,400			
**2	208	33.8	115,300					
45 kW	EHA150-45 208/230v (99J10) 460v (99J11) 575v (99J12) 42 lbs. (19 kg)	**2	208	33.8	115,300	171	174	180
		**2	220	37.8	129,000	189	192	198
		**2	230	41.3	141,000			
		**2	240	45.0	153,600			
		**2	440	37.8	129,000			
		**2	460	41.3	141,000	95	97	99
		**2	480	45.0	153,600			
		**2	550	37.8	129,000	76	77	79
		**2	575	41.3	141,000			
		**2	600	45.0	153,600			
**2	208	45.0	153,600					
60 kW	EHA150-60 208/230v (99J13) 460v (99J14) 575v (99J15) 49 lbs. (22 kg)	**2	208	45.0	153,600	179	182	188
		**2	220	50.4	172,000	198	201	207
		**2	230	55.1	188,000			
		**2	240	60.0	204,800			
		**2	440	50.4	172,000			
		**2	460	55.1	188,000	100	101	104
		**2	480	60.0	204,800			
		**2	550	50.4	172,000	79	81	83
		**2	575	55.1	188,000			
		**2	600	60.0	204,800			
**2	208	45.0	153,600					

*Refer to National or Canadian Electrical Code manual to determine wire, fuse and disconnect size requirements. Use wires suitable for at least 167°F (75°C).
 **May be used with two stage control.
 NOTE — Fuse block must be ordered extra. Factory installed heaters will have the fuse block factory installed. Fuse block must be installed in unit with field installed heaters. Also requires LTB2 Terminal Block.

TABLE 12

LHA 090								
kW Size Required	Electric Heat Model No. & Net Weight	No. of Steps	Volts Input	kW Input	Btuh Output	*Total Unit (with Power Exhaust Fan & Electric Heat Minimum Circuit Ampacity)		
						2 hp (1.5 kW)	3 hp (2.2 kW)	5 hp (3.7 kW)
7.5 kW	EHA102-7.5 208/230v (99J01) 460v (99J02) 575v (99J03) 31 lbs. (14 kg)	1	208	5.6	19,100	62	65	72
		1	220	6.3	21,500	65	68	75
		1	230	6.9	23,600			
		1	240	7.5	25,600			
		1	440	6.3	21,500	33	34	37
		1	460	6.9	23,600			
		1	480	7.5	25,600			
		1	550	6.3	21,500			
		1	575	6.9	23,600	26	27	29
		1	600	7.5	25,600			
15 kW	EHA150-15 208/230v (99J04) 460v (99J05) 575v (99J06) 31 lbs. (14 kg)	1	208	11.3	38,600	82	85	92
		1	220	12.6	43,000	88	91	98
		1	230	13.8	47,100			
		1	240	15.0	51,200			
		1	440	12.6	43,000	44	46	49
		1	460	13.8	47,100			
		1	480	15.0	51,200			
		1	550	12.6	43,000			
		1	575	13.8	47,100	35	36	38
		1	600	15.0	51,200			
30 kW	EHA150-30 208/230v (99J07) 460v (99J08) 575v (99J09) 38 lbs. (17 kg)	**2	208	22.5	76,800	121	124	131
		**2	220	25.2	86,000	133	136	143
		**2	230	27.5	93,900			
		**2	240	30.0	102,400			
		**2	440	25.2	86,000	67	68	71
		**2	460	27.5	93,900			
		**2	480	30.0	102,400			
		**2	550	25.2	86,000			
		**2	575	27.5	93,900	52	54	56
		**2	600	30.0	102,400			
45 kW	EHA150-45 208/230v (99J10) 460v (99J11) 575v (99J12) 42 lbs. (19 kg)	**2	208	33.8	115,300	160	163	170
		**2	220	37.8	129,000	178	181	188
		**2	230	41.3	141,000			
		**2	240	45.0	153,600			
		**2	440	37.8	129,000	89	91	94
		**2	460	41.3	141,000			
		**2	480	45.0	153,600			
		**2	550	37.8	129,000			
		**2	575	41.3	141,000	71	72	74
		**2	600	45.0	153,600			

*Refer to National or Canadian Electrical Code manual to determine wire, fuse and disconnect size requirements. Use wires suitable for at least 167°F (75°C).

**May be used with two stage control.

NOTE — Fuse block must be ordered extra. Factory installed heaters will have the fuse block factory installed. Fuse block must be installed in unit with field installed heaters. Also requires LTB2 Terminal Block.

E-Optional Electric Heat Components

Tables 4 through 12 show all possible LCA/LHA to EHA matchups and electrical ratings.

All electric heat sections consist of electric heating elements exposed directly to the airstream. See figure 25. EHA parts arrangement is shown in figures 26 and 27. Multiple-stage elements are sequenced on and off in response to thermostat demand.

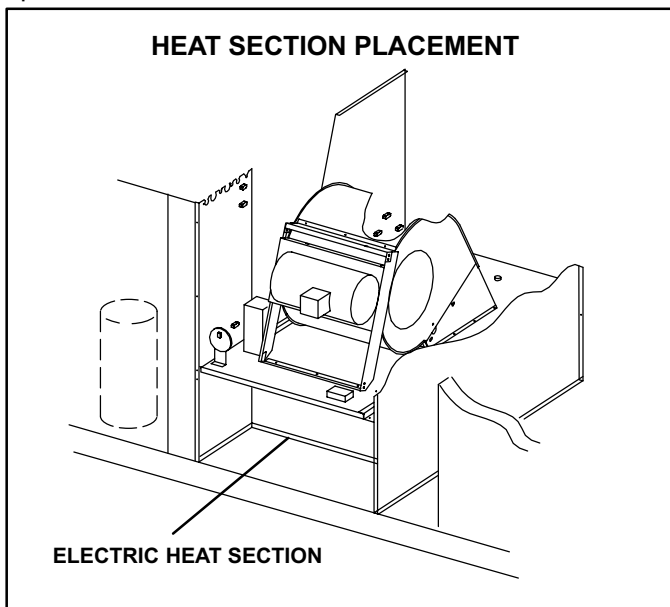

FIGURE 25

1-Main Control Box Components A55 and F4

The main control box (see figure 27) houses a few of the electric heat controls, such as: the main control module A55 and unit fuse block F4. For a description of module A55 and fuse block F4 see section I-A.

2-Contactors K15, K16

Contactors K15 and K16 are three-pole double-break contactors located on the electric heat vestibule. All contactors are equipped with a 24VAC coil. The coils in the K15 and K16 contactors are energized by the main panel A55. Contactor K15 energizes the first stage heating elements, while K16 energizes the second stage heating elements.

3-High Temperature Limits S15 (Primary)

S15 is a SPST N.C. auto-reset thermostat located on the back panel of the electric heat section below the heating elements. S15 is the high temperature limit for the electric heat section. When S15 opens, indicating a problem in the system, contactor K15 is de-energized. When K15 is de-energized, first stage and all subsequent stages of heat are de-energized. For EHA102/150 units, the electric heat section thermostat is factory set to open at $170^{\circ}\text{F} \pm 5^{\circ}\text{F}$ ($76^{\circ}\text{C} \pm 2.8^{\circ}\text{C}$) on a temperature rise and automatically reset at $130^{\circ}\text{F} \pm 6^{\circ}\text{F}$ ($54.4^{\circ}\text{C} \pm 3.3^{\circ}\text{C}$) on a temperature fall. For EHA100 units, the electric heat section thermostat is factory set to open at $160^{\circ}\text{F} \pm 5^{\circ}\text{F}$ ($71.0^{\circ}\text{C} \pm 2.8^{\circ}\text{C}$) on a temperature rise and automatically reset at $120^{\circ}\text{F} \pm 6^{\circ}\text{F}$ ($49.0^{\circ}\text{C} \pm 3.3^{\circ}\text{C}$) on a temperature fall. The thermostat is not adjustable.

4-High Temperature Limit S20 (Secondary)

S20 is a SPST N.C. manual-reset thermostat. Like the primary temperature limit, S20 is wired in series with the first stage contactor coil (K15) and second stage contactor coil (K16). When S20 opens, contactors (K15, K16) are de-energized. When the contactors are de-energized, first stage and all subsequent stages of heat are de-energized. The thermostat is factory set to open at $220^{\circ}\text{F} \pm 6^{\circ}\text{F}$ ($104^{\circ}\text{C} \pm 3.3^{\circ}\text{C}$) on a temperature rise and can be manually reset when temperature falls below 160°F (71.0°C).

5-Terminal Strip TB3

Electric heat line voltage connections are made to terminal strip TB3 (or a fuse block on some models) located in the upper left corner of the electric heat vestibule.

6-Heating Elements HE1, HE2, HE6 and HE7

Heating elements are composed of helix wound bare nichrome wire exposed directly to the airstream. Three elements are connected in a three-phase arrangement. The elements in 208/230V units are connected in a "Delta" arrangement. Elements in 460 and 575V units are connected in "Wye" arrangement. Each stage is energized independently by the corresponding contactors located on the electric heat vestibule panel. Once energized, heat transfer is instantaneous. High temperature protection is provided by primary and redundant high temperature limits and overcurrent protection is provided by fuses.

7-Fuse F3

Fuse F3 are housed in a fuse block which holds three fuses. Each F3 fuse is connected in series with each leg of electric heat. Figure 26 and table 13 show the fuses used with each electric heat section. For simplicity, the service manual labels the fuses F3 - 1 through F3 - 4.

TABLE 13

LCA / LHA ELECTRIC HEAT SECTION FUSE RATING					
EHA QUANTITY & SIZE	VOLTAGES	FUSE (3 each)			
		F3 - 1	F3 - 2	F3 - 3	F3 - 4
EHA100-7.5	208/230V	25 Amp 250V	---	---	---
	460V	15 Amp 600V	---	---	---
	575V	10 Amp 600V	---	---	---
EHA100-15	208/230V	50 Amp 250V	---	---	---
	460V	25 Amp 600V	---	---	---
	575V	20 Amp 600V	---	---	---
EHA100-22.5	208/230V	50 Amp 250V	---	---	25 Amp 250V
	460V	25 Amp 600V	---	---	15 Amp 600V
	575V	20 Amp 600V	---	---	10 Amp 600V
EHA100-30	208/230V	50 Amp 250V	---	---	50 Amp 250V
	460V	25 Amp 600V	---	---	25 Amp 600V
	575V	20 Amp 600V	---	---	20 Amp 600V
EHA100-45	208/230V	50 Amp 250V	---	60 Amp 250V	60 Amp 250V
	460V	25 Amp 600V	---	---	50 Amp 600V
	575V	20 Amp 600V	---	---	40 Amp 600V
EHA102-7.5	208/230V	25 Amp 250V	---	---	---
	460V	15 Amp 600V	---	---	---
	575V	10 Amp 600V	---	---	---
EHA150-15	208/230V	50 Amp 250V	---	---	---
	460V	25 Amp 600V	---	---	---
	575V	20 Amp 600V	---	---	---
EHA360-22.5	208/230V	50 Amp 250V	---	---	25 Amp 250V
	460V	25 Amp 600V	---	---	15 Amp 600V
	575V	20 Amp 600V	---	---	10 Amp 600V
EHA150-30	208/230V	50 Amp 250V	---	---	50 Amp 250V
	460V	25 Amp 600V	---	---	25 Amp 600V
	575V	20 Amp 600V	---	---	20 Amp 600V
EHA150-45	208/230V	50 Amp 250V	---	60 Amp 250V	60 Amp 250V
	460V	25 Amp 600V	---	---	50 Amp 600V
	575V	20 Amp 600V	---	---	40 Amp 600V
EHA150-60	208/230V	60 Amp 250V	60 Amp 250V	60 Amp 250V	60 Amp 250V
	460V	50 Amp 600V	---	---	50 Amp 600V
	575V	40 Amp 600V	---	---	40 Amp 600V

**EHA 7.5, 15, 22.5, 30, 45, 60KW
ELECTRIC HEAT SECTION PARTS ARRANGEMENT**

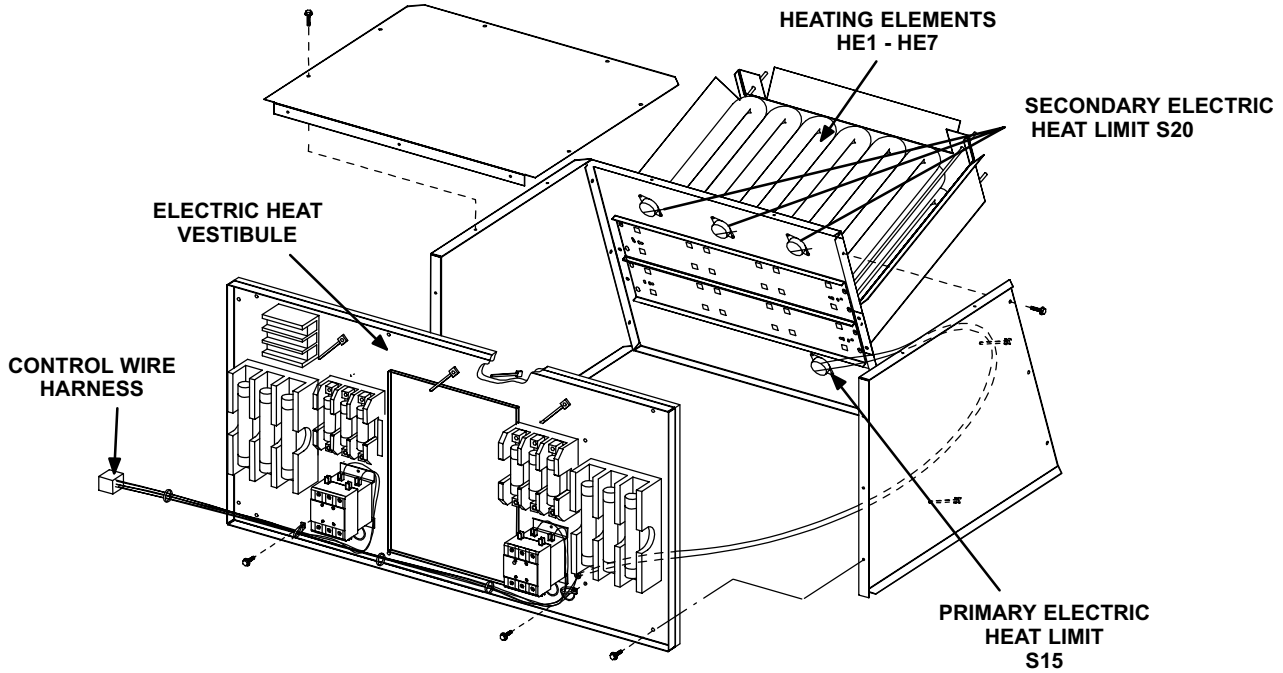

FIGURE 26

ELECTRIC HEAT VESTIBULE PARTS ARRANGEMENT

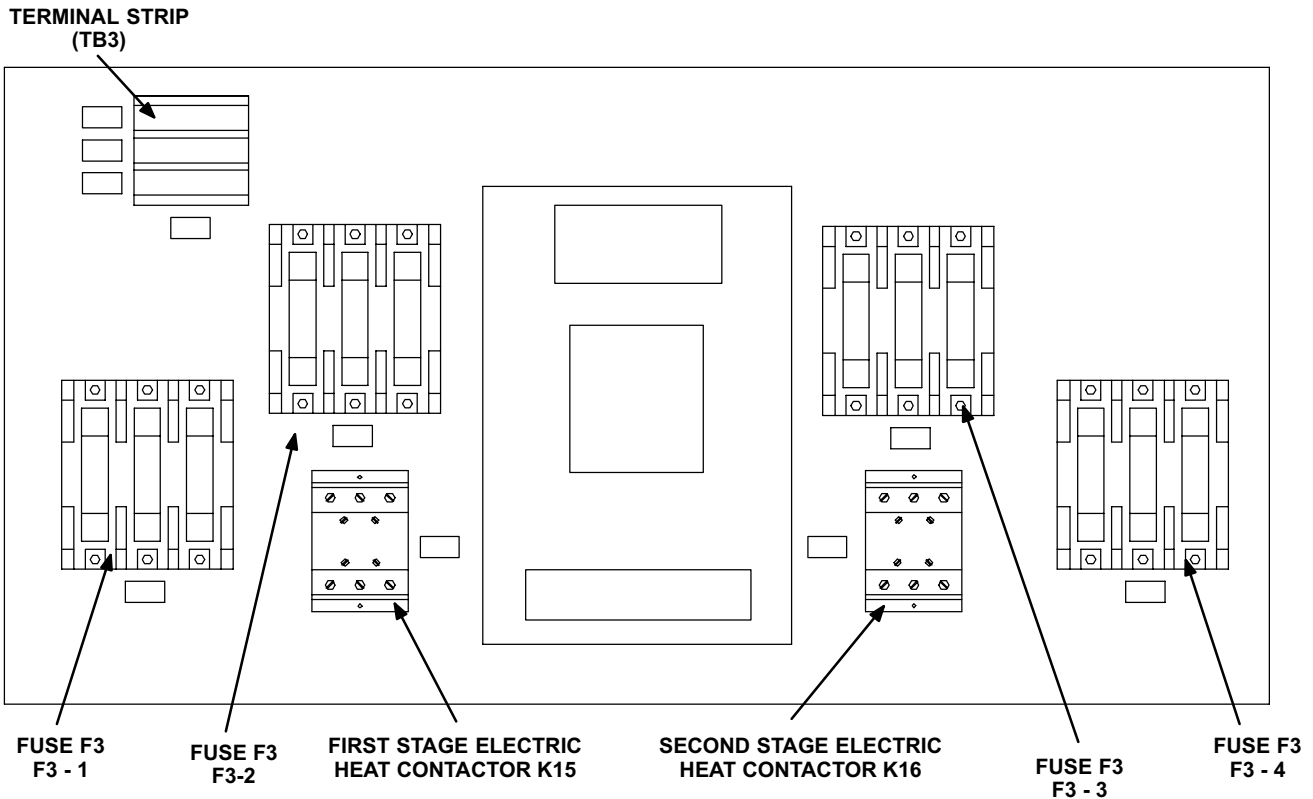

FIGURE 27

II-PLACEMENT AND INSTALLATION

Make sure the unit is installed in accordance with the installation instructions and all applicable codes. See accessories section for conditions requiring use of the optional roof mounting frame (LARMF).

III-CHARGING

WARNING-Do not exceed nameplate charge under any condition.

This unit is factory charged and should require no further adjustment. If the system requires charge, reclaim the charge, evacuate the system, and add required nameplate charge.

*NOTE - System charging is not recommended below 60° F (15° C). In temperatures below 60° F (15° C), the charge **must** be weighed into the system.*

If weighing facilities are not available, or to check the charge, use the following procedure:

- 1- Attach gauge manifolds and operate unit in cooling mode until system stabilizes (approximately five minutes). Make sure outdoor air dampers are closed.
- 2- Check each system separately with all stages operating.
- 3- Use a thermometer to accurately measure the outdoor ambient temperature.
- 4- Apply the outdoor temperature to tables 14 through 24 to determine normal operating pressures.
- 5- Compare the normal operating pressures to the pressures obtained from the gauges. Minor variations in these pressures may be expected due to differences in installations. Significant differences could mean that the system is not properly charged or that a problem exists with some component in the system. **Correct any system problems before proceeding.**
- 6- If discharge pressure is high, remove refrigerant from the system. If discharge pressure is low, add refrigerant to the system.
 - Add or remove charge in increments.
 - Allow the system to stabilize each time refrigerant is added or removed.
- 7- Use the following approach method along with the normal operating pressures to confirm readings.

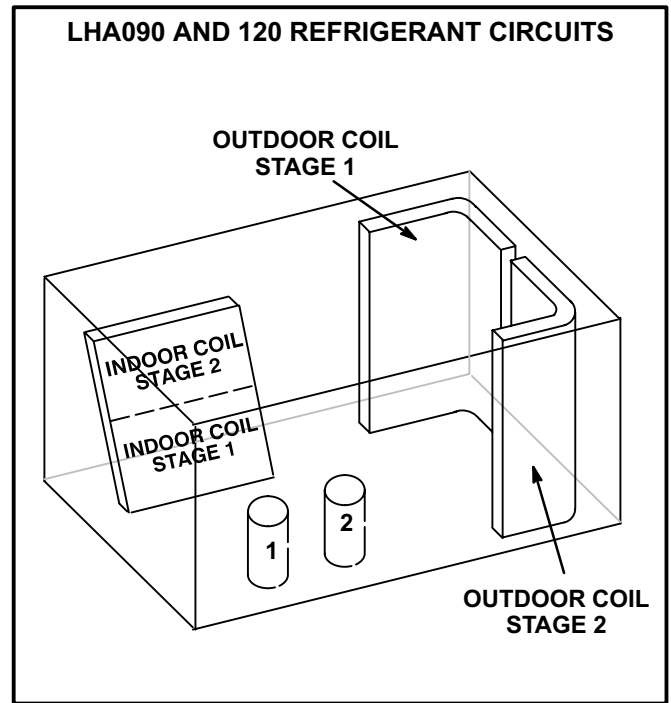

FIGURE 8

TABLE 14
LGA/LCA088S NORMAL OPERATING PRESSURES

Outdoor Coil Entering Air Temp.	CIRCUIT 1		CIRCUIT 2	
	Discharge ± 10 psig	Suction ± 5 psig	Discharge ± 10 psig	Suction ± 5 psig
65 F	186	71	183	70
75 F	211	72	208	72
85 F	238	74	235	74
95 F	270	77	269	77
105 F	304	78	302	78
115 F	342	81	340	80

TABLE 15
LGA/LCA088H NORMAL OPERATING PRESSURES

Outdoor Coil Entering Air Temp.	CIRCUIT 1		CIRCUIT 2	
	Discharge ± 10 psig	Suction ± 5 psig	Discharge ± 10 psig	Suction ± 5 psig
65 F	176	74	176	76
75 F	202	75	203	77
85 F	231	77	232	78
95 F	264	78	265	80
105 F	300	80	301	81
115 F	339	82	341	82

**TABLE 16
LHA088 NORMAL OPERATING PRESSURES**

Outdoor Coil Entering Air Temp.	Discharge ± 10 psig	Suction ± 5 psig
65°F	172	68
75°F	198	70
85°F	228	72
95°F	261	73
105°F	297	74
115°F	336	77

**TABLE 17
LHA090 NORMAL OPERATING PRESSURES**

Outdoor Coil Entering Air Temp.	CIRCUIT 1		CIRCUIT 2	
	Discharge ± 10 psig	Suction ± 5 psig	Discharge ± 10 psig	Suction ± 5 psig
65°F	OUTDOOR FAN CYCLES AT 65°F			
75°F	180	82	178	77
85°F	210	83	210	79
95°F	240	84	242	81
105°F	270	85	277	83
115°F	300	86	310	85

**TABLE 18
LGA/LCA100S NORMAL OPERATING PRESSURES**

Outdoor Coil Entering Air Temp.	CIRCUIT 1		CIRCUIT 2	
	Discharge ± 10 psig	Suction ± 5 psig	Discharge ± 10 psig	Suction ± 5 psig
65 F	185	73	185	73
75 F	212	74	213	74
85 F	241	75	242	75
95 F	275	76	277	76
105 F	312	78	314	78
115 F	352	79	355	79

**TABLE 19
LGA/LCA102S NORMAL OPERATING PRESSURES**

Outdoor Coil Entering Air Temp.	CIRCUIT 1		CIRCUIT 2	
	Discharge ± 10 psig	Suction ± 5 psig	Discharge ± 10 psig	Suction ± 5 psig
65°F	185	75	198	76
75°F	216	77	230	78
85°F	247	79	262	80
95°F	278	82	293	82
105°F	310	84	326	84
115°F	340	86	357	86

**TABLE 20
LCA/LGA102H NORMAL OPERATING PRESSURES**

Outdoor Coil Entering Air Temp.	CIRCUIT 1		CIRCUIT 2	
	Discharge ± 10 psig	Suction ± 5 psig	Discharge ± 10 psig	Suction ± 5 psig
65°F	155	78	163	78
75°F	185	79	193	79
85°F	216	80	222	80
95°F	246	81	252	82
105°F	277	82	282	84
115°F	308	83	311	85

**TABLE 21
LHA120 NORMAL OPERATING PRESSURES**

Outdoor Coil Entering Air Temp.	CIRCUIT 1		CIRCUIT 2	
	Dis. ± 10 psig	Suct. ± 5 psig	Dis. ± 10 psig	Suct. ± 5 psig
65°F	166	77	166	75
75°F	196	78	196	76
85°F	228	80	228	78
95°F	260	82	260	79
105°F	290	84	290	81
115°F	321	85	321	82

**TABLE 22
LCA/LGA120S NORMAL OPERATING PRESSURES**

Outdoor Coil Entering Air Temp.	CIRCUIT 1		CIRCUIT 2	
	Discharge ± 10 psig	Suction ± 5 psig	Discharge ± 10 psig	Suction ± 5 psig
65°F	183	76	186	73
75°F	212	78	215	75
85°F	242	80	246	77
95°F	272	82	276	79
105°F	303	84	306	81
115°F	333	85	337	83

**TABLE 23
LCA/LGA120H NORMAL OPERATING PRESSURES**

Outdoor Coil Entering Air Temp.	CIRCUIT 1		CIRCUIT 2	
	Discharge ± 10 psig	Suction ± 5 psig	Discharge ± 10 psig	Suction ± 5 psig
65°F	166	75	172	74
75°F	197	76	203	75
85°F	227	78	233	77
95°F	258	80	264	79
105°F	288	82	295	82
115°F	320	84	326	84

**TABLE 24
LGA/LCA150S NORMAL OPERATING PRESSURES**

Outdoor Coil Entering Air Temp.	CIRCUIT 1		CIRCUIT 2	
	Discharge ± 10 psig	Suction ± 5 psig	Discharge ± 10 psig	Suction ± 5 psig
65°F	183	65	187	66
75°F	215	68	219	69
85°F	248	71	252	72
95°F	281	74	285	74
105°F	313	77	317	77
115°F	347	79	350	80

Charge Verification - Approach Method

- 8- Using the same thermometer, compare liquid temperature to outdoor ambient temperature.

Approach Temperature = Liquid temperature minus ambient temperature.

- 9- Approach temperature should match values in tables 25, 26 or 27. An approach temperature greater than value shown indicates an undercharge. An approach temperature less than value shown indicates an overcharge.

- 10-Do not use the approach method if system pressures do not match pressures in tables 14 through 24. The approach method is not valid for grossly over or under-charged systems.

TABLE 25

LGA/ LCA/ LHA UNIT	APPROACH TEMPERATURE	
	LIQUID TEMP. MINUS AMBIENT TEMP.	
	1ST STAGE	2ND STAGE
088S	8°F ± 1 (4.4°C ± 0.5)	9°F ± 1 (5°C ± 0.5)
088H	7°F ± 1 (3.9°C ± 0.5)	8°F ± 1 (4.4°C ± 0.5)
100S	9°F ± 1 (5°C ± 0.5)	10°F ± 1 (5.6°C ± 0.5)
LHA 088S	15°F ± 1 (8°C ± 0.5)	N/A

TABLE 26

UNIT	APPROACH TEMPERATURE	
	LIQUID TEMP. MINUS AMBIENT TEMP.	
	1ST STAGE	2ND STAGE
LHA090	7°F ± 1 (3.9°C ± 0.5)	8°F ± 1 (4.4°C ± 0.5)
LHA120	9°F ± 1 (5°C ± 0.5)	11°F ± 1 (6°C ± 0.5)

TABLE 27

LGA/ LCA UNIT	APPROACH TEMPERATURE	
	LIQUID TEMP. MINUS AMBIENT TEMP.	
	1ST STAGE	2ND STAGE
102S	10°F ± 1 (5.6°C ± 0.5)	12°F ± 1 (6.7°C ± 0.5)
102H	6°F ± 1 (3.3°C ± 0.5)	7°F ± 1 (3.9°C ± 0.5)
120S	9°F ± 1 (5°C ± 0.5)	10°F ± 1 (5.6°C ± 0.5)
120H	6°F ± 1 (3.3°C ± 0.5)	7°F ± 1 (3.9°C ± 0.5)
150S	9°F ± 1 (5°C ± 0.5)	10°F ± 1 (5.6°C ± 0.5)

IV-STARTUP - OPERATION

Refer to startup directions and refer closely to the unit wiring diagram when servicing. See unit nameplate for minimum circuit ampacity and maximum fuse size.

A-Preliminary and Seasonal Checks

- 1- Make sure the unit is installed in accordance with the installation instructions and applicable codes.
- 2- Inspect all electrical wiring, both field and factory installed for loose connections. Tighten as required. Refer to unit diagram located on inside of unit control box cover.
- 3- Check to ensure that refrigerant lines are in good condition and do not rub against the cabinet or other refrigerant lines.
- 4- Check voltage at the disconnect switch. Voltage must be within the range listed on the nameplate. If not, consult the power company and have the voltage corrected before starting the unit.
- 5- Recheck voltage and amp draw with unit running. If voltage is not within range listed on unit nameplate, stop unit and consult power company. Refer to unit nameplate for maximum rated load amps.
- 6- Inspect and adjust blower belt (see section on Blower Compartment - Blower Belt Adjustment).

B-Cooling Startup LGA/LCA

NOTE-Crankcase heaters must be energized 24 hours before attempting to start compressor. Set thermostat so that there is no demand to prevent compressor from cycling. Apply power to unit.

- 1- Initiate first and second stage cooling demands according to instructions provided with thermostat.
- 2- First-stage thermostat demand will energize compressor 1. Second-stage thermostat demand will energize compressor 2. On units with an economizer, when outdoor air is acceptable, a first-stage demand will energize the economizer; a second-stage demand will energize compressor 1.
- 3- Units contain two refrigerant circuits or stages. See figure 28.
- 4- Each refrigerant circuit is separately charged with HCFC-22 refrigerant. See unit rating plate for correct amount of charge.
- 5- Refer to Cooling Operation and Adjustment section for proper method to check refrigerant charge.

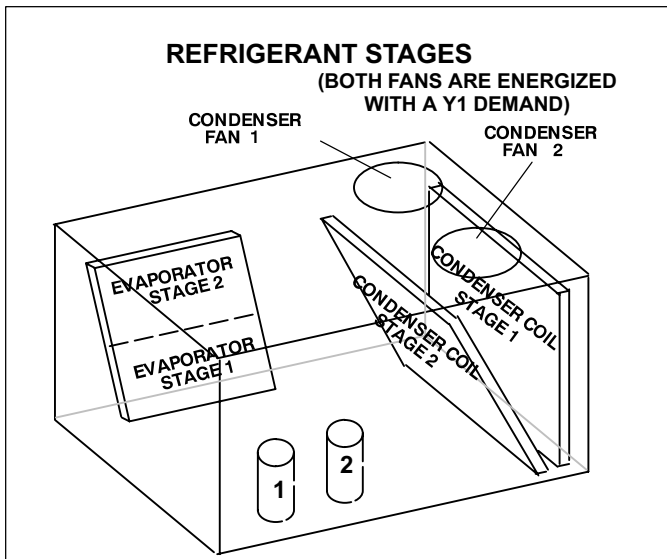

FIGURE 28

Three Phase Scroll Compressor Voltage Phasing

Three phase scroll compressors must be phased sequentially to ensure correct compressor and blower rotation and operation. Compressor and blower are wired in phase at the factory. Power wires are color-coded as follows: line 1-red, line 2-yellow, line 3-blue.

- 1- Observe suction and discharge pressures and blower rotation on unit start-up.
- 2- Suction pressure must drop, discharge pressure must rise, and blower rotation must match rotation marking.

If pressure differential is not observed or blower rotation is not correct:

- 3- Disconnect all remote electrical power supplies.
- 4- Reverse any two field-installed wires connected to the line side of S48 disconnect or TB13 terminal strip. Do not reverse wires at blower contactor.
- 5- Make sure the connections are tight.

Discharge and suction pressures should operate at their normal start-up ranges.

C-Cooling Startup LHA

NOTE-Crankcase heaters must be energized 24 hours before attempting to start compressor. Set thermostat so that there is no demand to prevent compressor from cycling. Apply power to unit.

- 1- Set thermostat or temperature control device fan switch to **AUTO** or **ON**. Set thermostat or temperature control device to initiate a first-stage cooling demand. A Y1 cooling demand will energize compressor B1.
Units With Optional Economizer -
The optional economizer will start on a first stage (Y1) cooling demand when outdoor air enthalpy is suitable. An increased cooling demand (Y2) will energize compressor B2.
- 2- Refrigerant circuit is factory charged with HCFC-22 refrigerant. See unit rating plate for correct amount of charge.

D-Heating Startup LGA

FOR YOUR SAFETY READ BEFORE LIGHTING

! WARNING	
	Electric shock hazard. Can cause injury or death. Do not use this furnace if any part has been under water. Immediately call a qualified service technician to inspect the furnace and to replace any part of the control system and any gas control which has been under water.

! WARNING	
	Danger of explosion. Can cause injury or product or property damage. If overheating occurs or if gas supply fails to shut off, shut off the manual gas valve to the appliance before shutting off electrical supply.

! WARNING	
	Electric shock hazard. Can cause injury or death. Before attempting to perform any service or maintenance, turn the electrical power to unit OFF at disconnect switch(es). Unit may have multiple power supplies.

BEFORE LIGHTING smell all around the appliance area for gas. Be sure to smell next to the floor because some gas is heavier than air and will settle on the floor.

Use only your hand to push in or turn the gas control knob. Never use tools. If the knob will not push in or turn by hand, do not try to repair it, call a qualified service technician. Force or attempted repair may result in a fire or explosion.

! WARNING	
	Danger of explosion. Can cause injury or death. Do not attempt to light manually. Unit has a direct spark ignition system.

This unit is equipped with an automatic spark ignition system. There is no pilot. In case of a safety shutdown, move thermostat switch to **OFF** and return the thermostat switch to **HEAT** to reset ignition control.

1-Placing Furnace In Operation

Gas Valve Operation for White Rodgers 36C and Honeywell VR8205Q/VR8305Q (figure 29)

- 1- Set thermostat to lowest setting.
- 2- Turn off all electrical power to appliance.
- 3- This appliance is equipped with an ignition device which automatically lights the burner. Do **not** try to light the burner by hand.
- 4- Open or remove the heat section access panel.
- 5- Turn the knob on the gas valve clockwise  to "OFF". Depress 36C knob slightly. Do not force.
- 6- Wait five (5) minutes to clear out any gas. If you then smell gas, **STOP!** Immediately call your gas supplier from a neighbor's phone. Follow the gas supplier's instructions. If you do not smell gas, go to the next step.

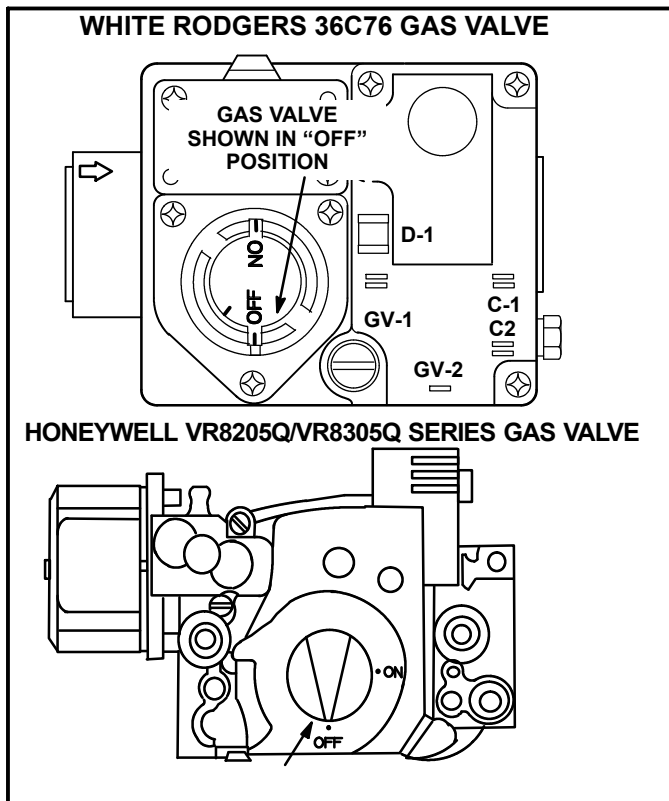



FIGURE 29

- 7- Turn the knob on the gas valve counterclockwise  to "ON". Do not force.
- 8- Close or replace the heat section access panel.
- 9- Turn on all electrical power to appliance.
- 10- Set thermostat to desired setting.
- 11- The combustion air inducer will start. The burners will light within 40 seconds.
- 12- If the appliance does not light the first time (gas line not fully purged), it will attempt up to two more ignitions before locking out.

13- If lockout occurs, repeat steps 1 through 10.

14- If the appliance will not operate, follow the instructions "Turning Off Gas to Appliance" and call your service technician or gas supplier.

Turning Off Gas to Appliance

- 1- If using an electromechanical thermostat, set to the lowest setting.
- 2- Before performing any service, turn off all electrical power to the appliance.
- 3- Open or remove the heat section access panel.
- 4- Turn the knob on the gas valve clockwise  to "OFF". Depress 36C knob slightly. Do not force.

E-Heating Startup LHA

- 1- Set thermostat or temperature control device to initiate a first-stage heating demand.

A first-stage heating demand (W1) will energize compressor. Outdoor fan is energized with a W1 demand. *LHA Units With Optional Electric Heat* - An increased heating demand (W2) will energize electric heat.

F-Safety or Emergency Shutdown

Turn off power to the unit.

V- SYSTEMS SERVICE CHECKS

A-LGA Heating System Service Checks

All LGA units are A.G.A and C.G.A. design certified without modification.

Before checking piping, check with gas company or authorities having jurisdiction for local code requirements. Refer to the LGA Installation, Operation and Adjustments instruction for more information.

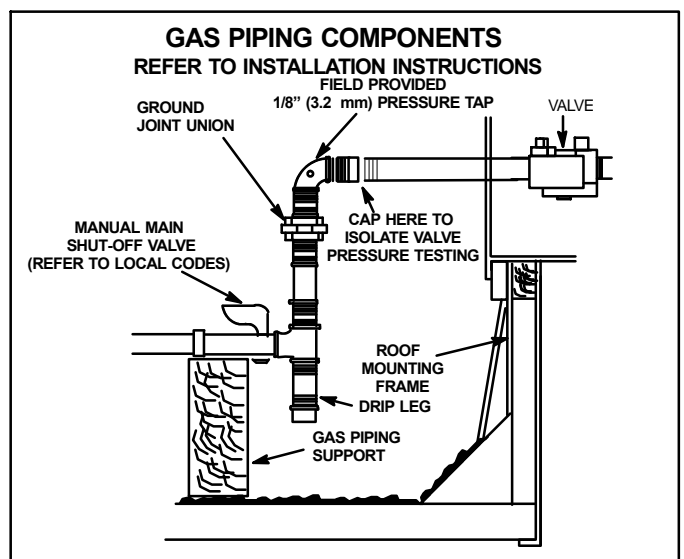

FIGURE 30

1-Gas Piping

Gas supply piping must not allow more than 0.5"W.C. (124.3 Pa) drop in pressure between the gas meter and the unit. Supply gas pipe must not be smaller than the unit gas connection. Refer to installation instructions for details.

2-Testing Gas Piping

NOTE-In case emergency shutdown is required, turn off the main manual shut-off valve and disconnect the main power to the unit. These controls should be properly labeled by the installer.

When pressure testing gas lines, the gas valve must be disconnected and isolated. **Gas valves can be damaged if subjected to more than 0.5 psig [14"W.C. (3481 Pa)].** See figure 30.

When checking piping connection for gas leaks, use the preferred means. Common kitchen detergents can cause harmful corrosion on various metals used in gas piping. The use of specialty Gas Leak Detector is strongly recommended. It is available through Lennox under part number 31B2001.

Do not use matches, candles, flame or any other source of ignition to check for gas leaks.

3-Testing Gas Supply Pressure

When testing gas supply pressure, connect test gauge to the inlet pressure tap (field provided - figure 30). Test supply gas pressure with unit firing at maximum rate (both stages energized). Make sure the reading falls within the range of the following values. Low pressure may result in erratic operation or "underfire." High pressure can result in permanent damage to the gas valve or "overfire." For natural gas units, operating pressure at the unit gas connection must be between 4.7"W.C. and 10.5"W.C. (1168 Pa and 2610 Pa) For L.P. gas units, operating pressure at the unit gas connection must be between 10.8"W.C. and 13.5"W.C. (2685.3 Pa and 3356.7 Pa).

On multiple unit installations, each unit should be checked separately while operating at maximum rate, beginning with the one closest to the supply gas main and progressing to the one furthest from the main. Multiple units should also be tested with and without the other units operating. Supply pressure must fall within the range listed in the previous paragraph.

4-Check and Adjust Manifold Pressure

After line pressure has been checked and adjusted, check manifold pressure. Move test gauge to the outlet pressure tap located on unit gas valve GV1. See figure 22 for location of pressure tap on the gas valve.

The manifold pressure is factory set and should not require adjustment. If manifold pressure is incorrect and no other source of improper manifold pressure can be found, the valve must be replaced. White-Rodgers gas valve can be adjusted for high fire only. Honeywell valves are adjustable for both high and low fire. Refer to figure 22 for location of gas valve (manifold pressure) adjustment screw. See table 3 for factory set manifold pressure.

All gas valves are factory regulated. The gas valve should completely and immediately cycle off in the event of gas or power failure. The manual shut-off knob can be used to immediately shut off gas supply.

CAUTION

For safety, connect a shut-off valve between the manometer and the gas tap to permit shut off of gas pressure to the manometer.

Manifold Adjustment Procedure

- 1- Connect test gauge to the outlet pressure tap on the gas valve. Start the unit (call for second stage heat) and allow five minutes for the unit to reach steady state.
- 2- While waiting for the unit to stabilize, notice the flame. The flame should be stable without flashback and should not lift from the burner heads. Natural gas should burn basically blue with some clear streaks. L.P. gas should burn mostly blue with some clear yellow streaks.
- 3- After allowing the unit to stabilize for five minutes, record the manifold pressure and compare to the values given for gas supply pressure (above).

CAUTION

Disconnect heating demand as soon as an accurate reading has been obtained.

5-Proper Gas Flow

To check for proper gas flow to burners, determine Btuh input from unit rating plate or the gas heating capacity table on page 3. Divide this input rating by the Btuh per cubic foot of available gas. Result is the number of cubic feet per hour required. Determine the flow of gas through gas meter for two minutes and multiply by 30 to get hourly flow of gas to the burners.

NOTE - To obtain accurate reading, shut off all other gas appliances connected to meter.

6-High Altitude Derate

Natural gas units may be installed at altitudes up to 2000 feet (610m) above sea level without any modification. At altitudes above 2000 feet (610 m), units must be derated to match gas manifold pressures shown in the following table.

NOTE-This is the only permissible derate for these units.

TABLE 28

Altitude - ft. (m)	Gas Manifold Pressure - in. w.g. (kPa)
2001 - 3000 (610 - 915)	3.6 (0.90)
3001 - 4000 (915 - 1220)	3.5 (0.87)
4001 - 5000 (1220 - 1525)	3.4 (0.85)
5001 - 6000 (1525 - 1830)	3.3 (0.82)
6001 - 7000 (1830 - 2135)	3.2 (0.80)
7001 - 8000 (2135 - 2440)	3.1 (0.77)

Derate Procedure:

- 1- Check manifold pressure at the gas valve pressure tap with unit operating at high fire (second stage).
- 2- To reduce maximum input, turn regulator adjusting screw (figure 22) counterclockwise.
- 3- Re-check manifold pressure.

7-Inshot Burner

Burners are factory set for maximum air and cannot be adjusted. Always operate unit with access panel in place. A peep hole is furnished in the heating access panel for flame viewing. Natural gas should burn basically blue with some clear streaks. L.P. gas should burn mostly blue with some clear yellow streaks.

Figure 31 shows how to remove burner assembly.

- 1- Turn off power to unit and shut off gas supply.
- 2- Remove screws holding the burner support cap.
- 3- Slide each burner off its orifice.
- 4- Clean and reassemble (reverse steps 1-3).
- 5- Be sure to secure all wires and check plumbing.
- 6- Turn on power to unit. Follow lighting instructions attached to unit and operate unit in heating mode. Check burner flames. They should be blue with yellow streaks.

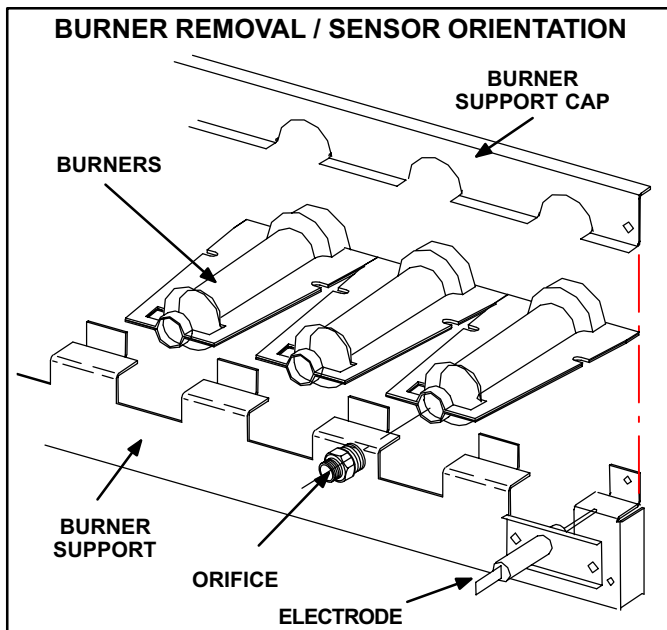
**FIGURE 31****8-Heat Exchanger**

To Access or Remove Heat Exchanger From Unit:

- 1- Turn off gas and electric power.
- 2- Remove access panel(s) and unit center mullion.
- 3- Remove gas valve, manifold assembly and burners.
- 4- Remove combustion air blower and flue box. Pay careful attention to the order in which gaskets and orifice are removed.
- 5- Support heat exchanger (to prevent it from falling when final screws are removed.)
- 6- Remove screws supporting heat exchanger.
- 7- To install heat exchanger, reverse procedure. Be sure to secure all wires and check plumbing and burner plate for airtight seal. Screws must be torqued to 35 in.-lbs. (4N.m) to ensure proper operation.

9-Spark Electrode Gap

The spark electrode assembly can be removed for inspection by removing two screws securing the electrode assembly and sliding it out of unit.

For proper unit operation, electrodes must be positioned and gapped correctly.

Spark gap may be checked with appropriately sized twist drills or feeler gauges. Disconnect power to the unit and remove electrode assembly. The gap should be between 0.125" ± 0.015" (3.2 mm ± .4 mm). See figure 23.

10-Flame Sensing

Flame current is an electrical current which passes from the ignition control through the sensor electrode during unit operation. The current passes from the sensor through the flame to the ground electrode (located on the flame electrode) to complete a safety circuit. The electrodes should be located so the tips are at least 1/2" (12.7 mm) inside the flame envelope. Do not bend electrodes. To measure flame current, follow the procedure below:

⚠ DANGER

Electrodes are not field adjustable. Any alterations to the electrode may cause a hazardous condition that can cause property damage or personal injury.

- 1- Disconnect power to unit.
- 2- Remove lead from sensing electrode and install a microamp meter in series between the sensing electrode and the sensing lead.
- 3- Reconnect power and adjust thermostat for heating demand.
- 4- When flame is established compare to table 29. Do not bend electrodes.
- 5- Disconnect power to unit before disconnecting meter. Make sure sensor wire is securely reconnected before reconnecting power to unit.

TABLE 29

Manufacturer	Nominal Signal Microamps	Drop Out
RAM	1.7-3.6	0.5
JOHNSON	0.5-1.0	.09
FENWALL	1.7-3.6	0.7

NOTE-If the meter scale reads 0, the leads are reversed. Disconnect power and reconnect leads for proper polarity.

11-Combustion Air Inducer

The combustion air inducer is factory set and is not field adjustable. However, operation should be monitored to ensure proper operation. The combustion air inducer is used to draw fresh air into the combustion chamber while simultaneously expelling exhaust gases. The inducer operates throughout the heating cycle.

On a heating demand, the ignition control is energized by the main control module A55. The ignition control then allows 30 to 40 seconds for the combustion air inducer to vent exhaust gases from the burners. When the combustion air inducer is purging the exhaust gases, the combustion air prove switch is closing proving that the combustion air inducer is operating before allowing the ignition control to energize. When the combustion air prove switch is closed and the delay is over, the ignition control activates the first stage operator of the gas valve (low fire), the spark and the flame sensing electrode. Sparking stops immediately after flame is sensed.

B-Cooling System Service Checks

See Charging section of this manual for Cooling service checks.

VI-MAINTENANCE

CAUTION

Electrical shock hazard. Turn off power to unit before performing any maintenance, cleaning or service operation on the unit.

A-Filters

LGA / LCA / LHA090/102/120/150 units are equipped with four 18" x 24" x 2" (457mm x 610mm x 51mm) pleated throw-away type filters. LGA/LCA/LHA088/100 units are equipped with four 18" x 20" x 2" (457mm x 508mm x 51mm). Filters may be accessed through the economizer / filter access door at the end of the unit. Filters should be checked monthly (or more frequently in severe use) and cleaned or replaced regularly. Take note of the "AIR FLOW DIRECTION" marking on the filter frame when re-installing.

NOTE-Filters must be U.L.C. certified or equivalent for use in Canada.

B-Lubrication

All motors and blower wheels used in LGA / LCA / LHA units are prelubricated; no further lubrication is required.

C-Supply Air Blower Wheel

Annually inspect supply air blower wheel for accumulated dirt or dust. Turn off power before attempting to remove access panel or to clean blower wheel.

CAUTION

Be careful when servicing unit to avoid accidental contact with sharp metallic edges which may cause personal injury.

D-Evaporator Coil

Inspect and clean coil at beginning of each season. Clean using mild detergent or commercial coil cleanser. Check condensate drain pan and line, if necessary. Flush coil and condensate drain with water taking care not to get insulation, filters and return air ducts wet. Check connecting lines and coil for evidence of oil and refrigerant leaks.

E-Condenser Coil

Clean condenser coil annually with detergent or commercial coil cleaner and inspect monthly during the cooling season. Check connecting lines and coil for evidence of oil and refrigerant leaks.

NOTE-If owner complains of insufficient cooling, the unit should be gauged and refrigerant charge checked.

Refer to Gauge Manifold Attachment and Charging sections in this manual.

F-Electrical

- 1- Check all wiring for loose connections.
- 2- Check for correct voltage at unit (unit operating).
- 3- Check amp-draw on both condenser fan motor and blower motor.

Fan Motor Rating Plate _____ Actual _____

Indoor Blower Motor Rating Plate _____ Actual _____

VII-ACCESSORIES

The accessories section describes the application of most of the optional accessories which can be factory or field installed to either the LGA / LCA / LHA units. OPTIONAL FIELD INSTALLED ACCESSORIES section (see table of contents) show specific size per unit.

A-LARMF Mounting Frames

When installing either the LGA / LCA / LHA units on a combustible surface for downflow discharge applications, the Lennox LARMF08/10 or 10/15 14-inch or 24-inch (356 mm or 610mm) height roof mounting frame is used. The roof mounting frames are recommended in all other applications but not required. If the LGA / LCA / LHA units are not mounted on a flat (roof) surface, they MUST be supported under all edges and under the middle of the unit to prevent sagging. The units MUST be mounted level within 1/16" per linear foot or 5mm per meter in any direction.

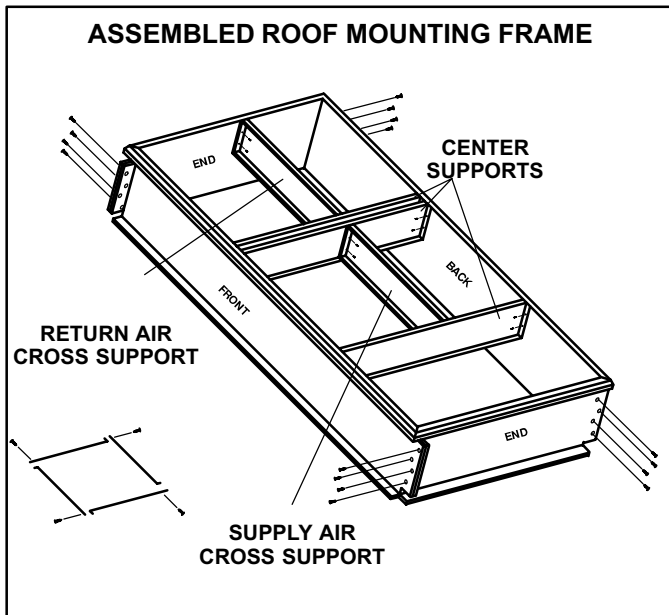

FIGURE 32

The assembled LARMF mounting frame is shown in figure 32. Refer to the roof mounting frame installation instructions for details of proper assembly and mounting. The roof mounting frame MUST be squared to the roof and level before mounting. Plenum system MUST be installed before the unit is set on the mounting frame. Typical roof curbing and flashing is shown in figure 33. Refer to the roof mounting frame installation instructions for proper plenum construction and attachment.

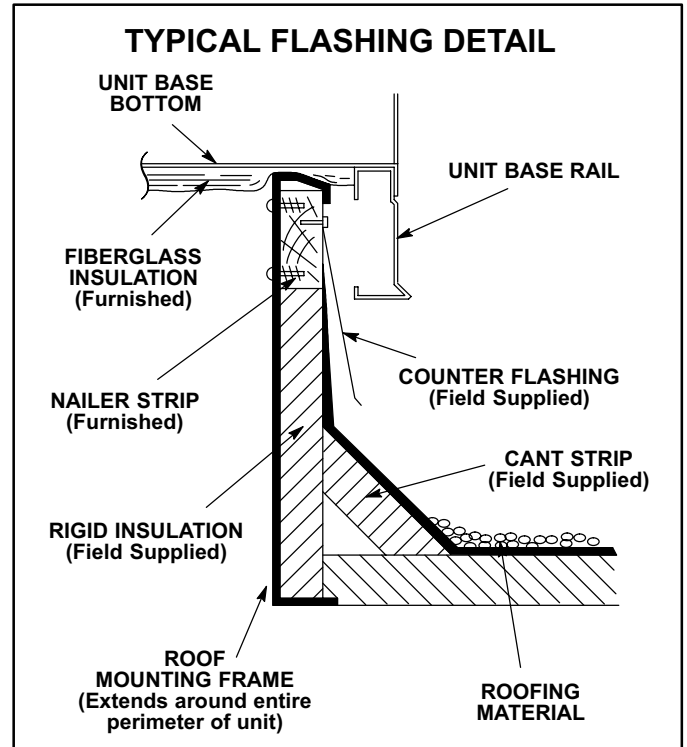

FIGURE 33

B-Transitions

Optional supply/return transitions LASRT08/10 and 10/12 are available for use with LGA/LCA/LHA 7.5, 8.5, and 10 ton series units, utilizing optional LARMF08/10 and 10/15 roof mounting frame. LGA / LCA / LHA 12.5 ton units will use LASRT15 with LARMF10/15 roof mounting frame. Transition must be installed in the LARMF mounting frame before mounting the unit to the frame. Refer to the manufacturer's instructions included with the transition for detailed installation procedures. LASRT10/12 and LASTR15 are included with factory installed economizers.

C-Supply and Return Diffusers

Optional flush mount diffuser/return FD11 and extended mount diffuser/return RTD11 are available for use with the LGA / LCA / LHA units. Refer to manufacturer's instructions included with transition for detailed installation procedures.

D-LAODM08/10, 10/15 and LAOD10/15

Outdoor Air Dampers

Field or Factory Installed

LAOADM08/10 and 10/15 and LAOD10/15 consists of dampers which may be manually or motor (M) operated to allow up to 25 percent outside air into the system at all times (see figure 34). Washable filters supplied with the outdoor air dampers can be cleaned with water and a mild detergent. It should be sprayed with Filter Handicoater when dry prior to reinstallation. Filter Handicoater is R.P. Products coating no. 418 and is available as Lennox Part No. P-8-5069.

E-LAREMD08/10 and 10/15 Economizer

(Field or Factory Installed)

The optional LAREMD08/10 and 10/15 economizer can be used with LGA / LCA / LHA units in downflow and horizontal air discharge applications. The LAREMD08/10 and 10/15 economizer uses outdoor air for free cooling when temperature and/or humidity is suitable. An economizer hood is required and must be ordered separately with the field installed economizer.

NOTE - Gravity exhaust dampers are optional with economizers.

The economizer is controlled by the economizer control module A56 which connects to the main control module A55. Both boards are part of the Integrated Modular Control (IMC) which controls "L" series unit operation.

The economizer will operate in one of four modes. Each mode requires a different EM1 economizer DIP switch setting. Each mode also requires different sensors.

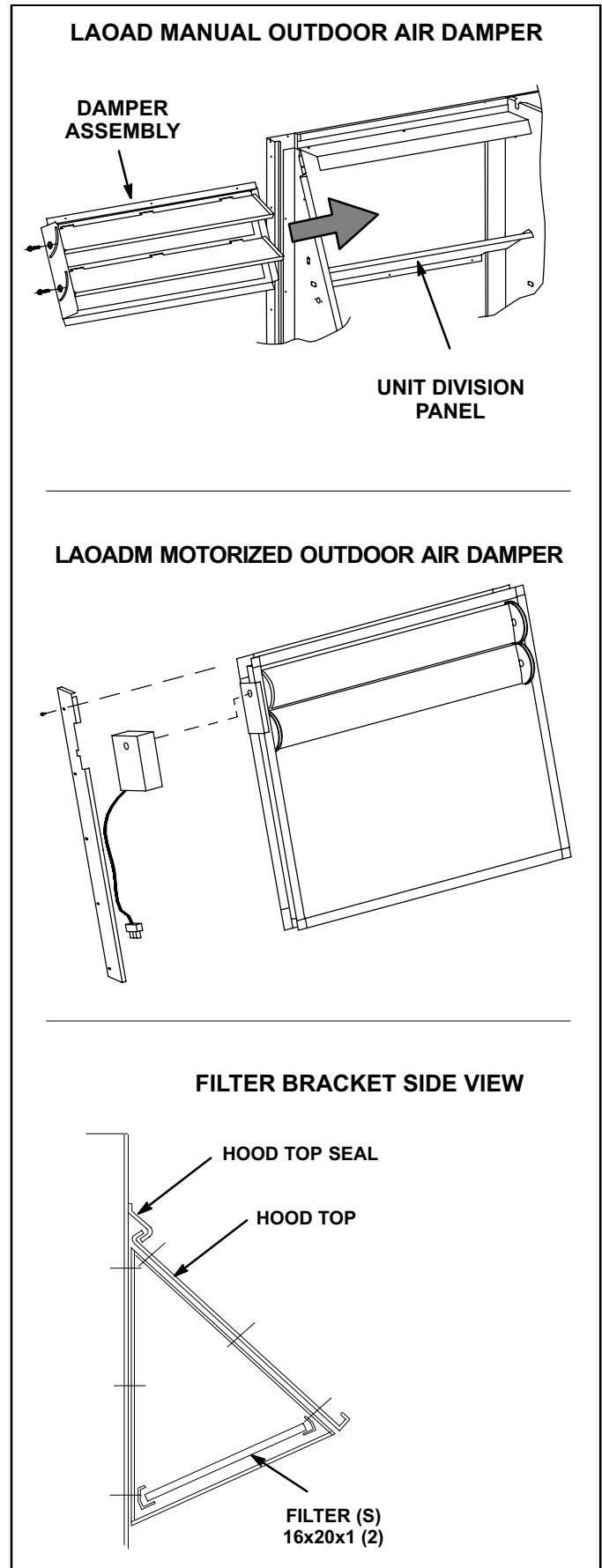

FIGURE 34

1-“TMP” MODE (SENSIBLE TEMPERATURE)

In the TMP” mode, the IMC uses input from the factory installed RT6 Supply Air Sensor, RT16 Return Air Sensor, and RT17 Outdoor Air Sensor to determine suitability of outside air and economizer damper operation. When outdoor sensible temperature is less than return air sensible temperature, outdoor air is used for cooling. This may be supplemented by mechanical cooling to meet comfort demands. This application does not require additional optional sensors.

2-“ODE” MODE (OUTDOOR ENTHALPY)

The “ODE” or outdoor enthalpy mode requires a field (16K96) or factory provided and installed Honeywell C7400 enthalpy sensor. The sensor monitors outdoor air temperature and humidity (enthalpy). When outdoor air enthalpy is below the enthalpy control setpoint, the economizer modulates to allow outdoor air for free cooling.

3-“DIF” MODE (DIFFERENTIAL ENTHALPY)

The “DIF” or differential enthalpy mode requires two field (16K97) or factory provided and installed Honeywell C7400 enthalpy sensors . One sensor is installed in the outside air opening and the other sensor is installed in the return air opening. When the outdoor air enthalpy is below the return air enthalpy, the economizer opens to bring in outdoor air for free cooling.

4-“GLO” MODE (GLOBAL)

Global Mode - The “GLO” or global mode is used with an energy management system which includes a global control feature. Global control is used when multiple units (in one location) respond to a single outdoor air sensor. Each energy management system uses a specific type of outdoor sensor which is installed and wired by the controls contractor.

Motorized Outdoor Air Damper - The “GLO” mode is also used when a motorized outdoor air damper is installed in the system regardless of whether an energy management system is used.

NOTE - All economizer modes of operation will modulate dampers to 55° F (13° C) supply air.

F-LAGED08/10 and 10/15 and LAGEDH10/15 Gravity Exhaust Dampers

LAGED08/10 and 10/15 and LAGEDH10/15 dampers are used with LGA / LCA / LHA series units. LAGED dampers are used in downflow (see figure 35) and LAGEDH are used in horizontal air discharge applications. LAGEDH gravity exhaust dampers are installed in the return air duct. The dampers must be used any time an economizer and a power exhaust fan is applied to LGA / LCA / LHA series units.

Gravity exhaust dampers allow exhaust air to be discharged from the system when an economizer and/or power exhaust is operating. Gravity exhaust dampers also prevent outdoor air infiltration during unit off cycle. See installation instructions for more detail.

NOTE- GED is optional except required with power exhaust dampers.

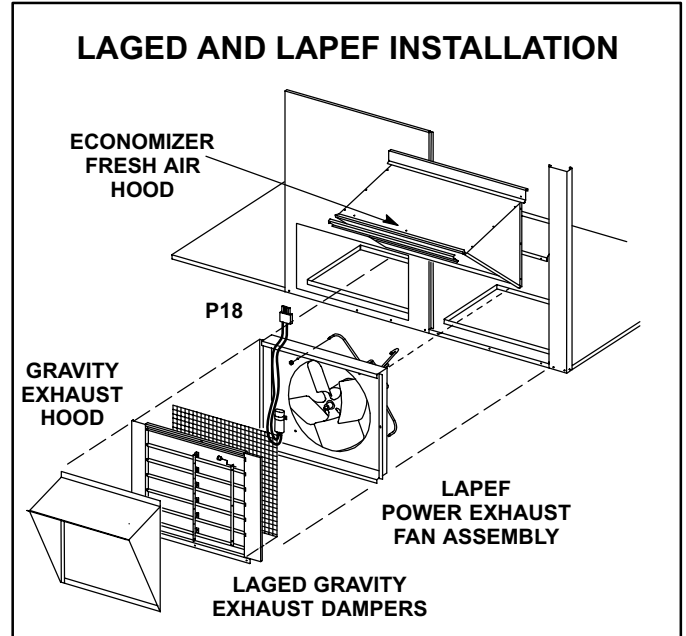

FIGURE 35

G-LAPEF08/10 and 10/15 Power Exhaust Fan

LAPEF10/15 power exhaust fan is used with LGA / LCA / LHA series units. LAPEF (requires optional down-flow gravity exhaust dampers and LAREMD economizers) is used in down-flow applications only. The power exhaust fan provides exhaust air pressure relief and also runs when return air dampers are closed and the supply air blower is operating. Figure 35 shows location of the LAPEF. See installation instructions for more detail.

H-Optional Cold Weather Kit (Canada only)

Electric heater is available to automatically control the minimum temperature in the gas burner compartment. Heater is C.G.A. certified to allow cold weather operation of unit down to -60°F (-50° C).

The kit includes the following parts:

- 1- Transformer (T20) is a 600V to 120/240V stepdown transformer mounted in the blower compartment.
- 2- T20 has two in line fuses (F20), one on each leg of the transformer. Both are rated at 15 amps.
- 3- The strip heater (HR6) is located as close as possible to the gas valve. It is wired in series with T20. The strip heater is rated at 500 Watts

4- A thermostat mounting box is installed on the vestibule of the heating compartment. Included in the box are the following thermostat switches:

- a - Thermostat switch (S59) is an auto-reset SPST switch which acts as a low limit and opens on a temperature drop. The switch is wired to open 24v power to the burner control. When the temperature drops below -35°C (-30°F) the switch opens and the gas heat section is de-energized. The switch automatically resets when the heating compartment temperature reaches -12°C (10°F).
- b - Thermostat switch (S60) is an auto-reset SPST switch and is the controller of HR6. When the temperature rises above -7°C (20°F) the switch opens and the electric heater is de-energized. The switch automatically resets when the heating compartment temperature reaches -23.3°C (-10°F).
- c - Thermostat switch (S61) is an auto-reset SPST switch which acts as a high limit and closes on a temperature drop. S61 remains closed during low ambient conditions and opens when temperatures rise. When temperature drops below -6.7°C (20°F) the switch closes. The switch automatically opens when heating compartment temperature reaches 24°C (76°F).

I-Control Systems

Three different types of control systems may be used with the LGA / LCA / LHA series units. All thermostat wiring is connected to terminal block TB1 located in the control box of the unit. Each thermostat has additional control options available. See thermostat installation instructions for more detail.

NOTE-Lennox LHA heat pumps use standard heat cool type thermostats. Attempted use of heat pump type thermostat on LHA unit will result in improper operation.

- 1- Electro-mechanical thermostat (13F06)
The electro-mechanical thermostat is a two stage heat / two stage cool thermostat with dual temperature levers. A non-switching or manual system switch subbase may be used.
- 2- Electronic thermostat (see price book)
Any two stage heat / two stage cool electronic thermostat may be used.
- 3- Honeywell T7300 thermostat (81G59)
The Honeywell T7300 thermostat is a programmable, internal or optional remote temperature sensing thermostat. The T7300 provides occupied and unoccupied changeover control.

J-Smoke Detectors A17 and A64

Photoelectric smoke detectors are a factory installed option. The smoke detectors can be installed in the supply air section (A64), return air section (A17), or in both the supply and return air section. Wiring for the smoke detector is shown on the ELECTRONIC OR ELECTROMECHANICAL THERMOSTAT diagram in the back of this manual.

K-Blower Proving Switch S52

The blower proving switch monitors blower operation and locks out the unit in case of blower failure. The switch is N.O. and closes at .14" W.C. (34.9 Pa) The switch is mounted on the upper left hand corner of the blower deck. Wiring for the blower prove switch is shown on the ELECTRONIC OR ELECTROMECHANICAL THERMOSTAT diagram in the back of this manual.

L-Dirty Filter Switch S27

The dirty filter switch senses static pressure increase indicating a dirty filter condition. The switch is N.O. and closes at 1" W.C. (248.6 Pa) The switch is mounted on the top filter channel corner. Wiring for the dirty filter switch is shown on the ELECTRONIC OR ELECTROMECHANICAL THERMOSTAT diagram in the back of this manual.

M-Indoor Air Quality (CO₂) Sensor A63

The indoor air quality sensor monitors CO₂ levels and reports the levels to the main control module A55. The board adjusts the economizer dampers according to the CO₂ levels. The sensor is mounted next to the indoor thermostat or in the return air duct. Refer to the indoor air quality sensor installation instructions for proper adjustment. Wiring for the indoor air quality switch is shown on the ELECTRONIC OR ELECTROMECHANICAL THERMOSTAT diagram in the back of this manual.

N-LP / Propane Kit

A natural to LP / propane gas changeover kit is required for gas conversion on LGA088/100/102/120/150 series units. The kit includes a gas valve and burner orifices.

VIII- WIRING DIAGRAMS / SEQUENCE OF OPERATION

LGA/LCA088-100 UNIT WIRING DIAGRAM

24V POWER

KEY	DESCRIPTION
A55	PANEL-MAIN
A56	PANEL-ECONOMIZER
A57	PANEL-COMPRESSOR 2
B1	COMPRESSOR 1
B2	COMPRESSOR 2
B3	MOTOR-BLOWER
B4	MOTOR-OUTDOOR FAN 1
B10	MOTOR-EXHAUST FAN 1
C1	CAPACITOR-OUTDOOR FAN 1
C6	CAPACITOR-EXHAUST FAN 1
CBB	CIRCUIT BREAKER-TRANS T1

KEY	DESCRIPTION
HR1	HEATER-COMPRESSOR 1
HR2	HEATER-COMPRESSOR 2
J11	JACK-GFI RECEPTACLE
J18	JACK-EXHAUST FAN COMPT
J24	JACK-EXHAUST FAN
J47	JACK-OUTDOOR FAN 1
J111	JACK-GAS 1 OUTPUT
J112	JACK-COOLING SENSOR INPUT
J113	JACK-BLOWER & COOL 1 CONTROL
J114	JACK-SENSOR INPUT
J115	JACK-ECONOMIZER OUTPUT
J116	JACK-COMPRESSOR 2
J132	JACK-B10 EXHAUST FAN MOTOR
J167	JACK-BLOWER OVERRIDE, STD
K1, -1	CONTACTOR-COMPRESSOR 1
K2, -1	CONTACTOR-COMPRESSOR 2
K3, -1	CONTACTOR-BLOWER
K10, -1,2	RELAY-OUTDOOR FAN
K65, -1,2	RELAY-EXHAUST FAN 1
P18	PLUG-EXHAUST FAN COMPT
P24	PLUG-EXHAUST FAN
P47	PLUG-OUTDOOR FAN 1
P111	PLUG-GAS 1 OUTPUT
P112	PLUG-COOLING SENSOR INPUT
P113	PLUG-BLOWER & COOL 1 CONTROL
P114	PLUG-SENSOR INPUT
P115	PLUG-ECONOMIZER OUTPUT
P116	PLUG-COMPRESSOR 2
P132	PLUG-B10 EXHAUST FAN MOTOR
S4	SWITCH-LIMIT HI PRESS, COMP 1
S7	SWITCH-LIMIT HI PRESS, COMP 2
S11	SWITCH-LOW PRESS, LOW AMB KIT
S42	OVERLOAD-RELAY, BLOWER MTR
S48	SWITCH-DISCONNECT
S49	SWITCH-FREEZESTAT, COMP 1
S50	SWITCH-FREEZESTAT, COMP 2
S84	SWITCH-LOW PRESS, LOW AMB, COMP 2
S87	SWITCH-LOW PRESS, COMP 1
S88	SWITCH-LOW PRESS, COMP 2
T1	TRANSFORMER-CONTROL
TB13	TERMINAL STRIP-POWER DISTRIB
TB34	TERMINAL STRIP-TRANS T1

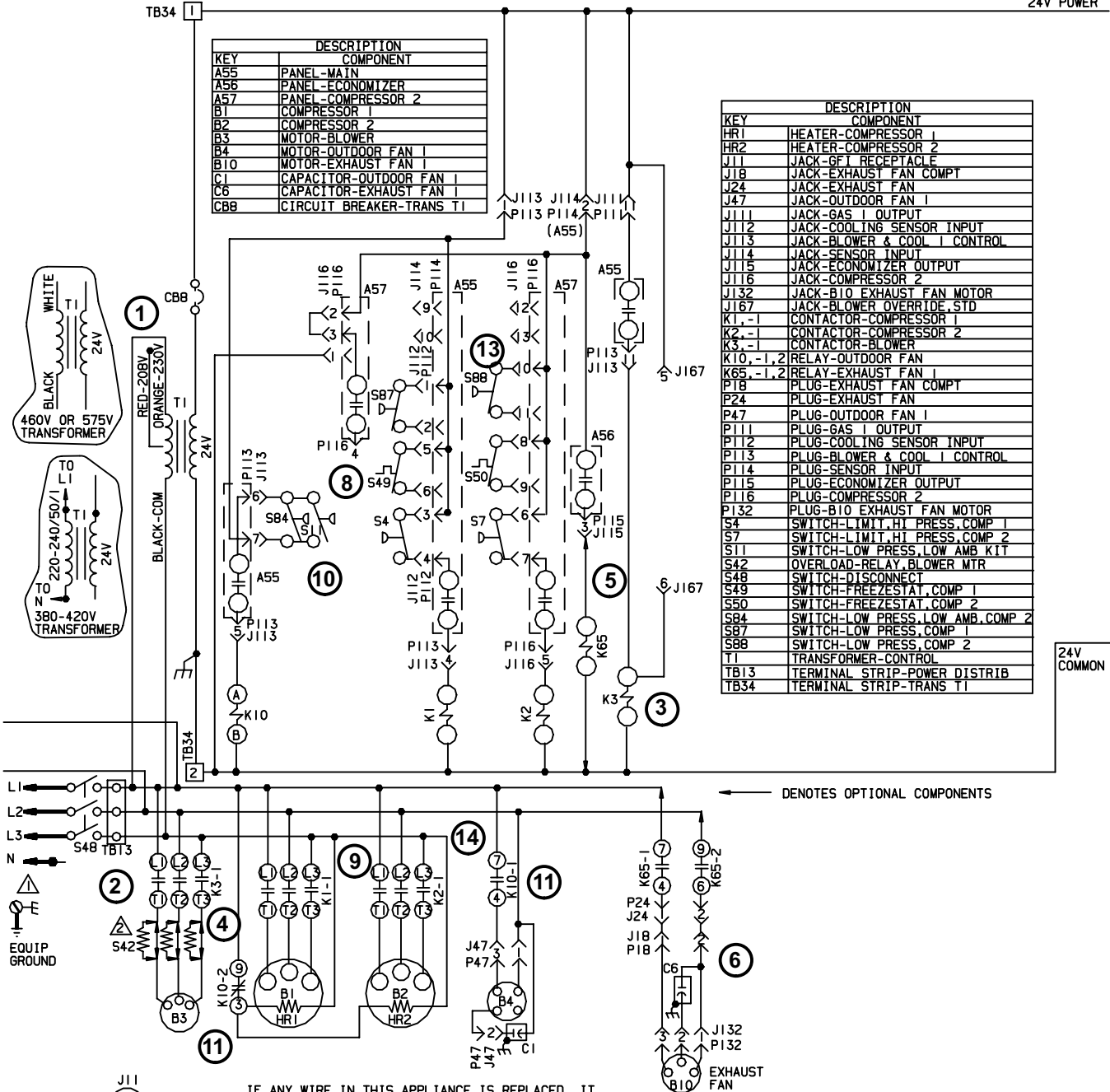

← DENOTES OPTIONAL COMPONENTS

IF ANY WIRE IN THIS APPLIANCE IS REPLACED, IT MUST BE REPLACED WITH WIRE OF LIKE SIZE, RATING AND INSULATION THICKNESS
 DISCONNECT ALL POWER BEFORE SERVICING
 THERMOSTAT HEAT ANTICIPATION SETTING 0.1 AMP
WARNING-ELECTRIC SHOCK HAZARD, CAN CAUSE INJURY OR DEATH. UNIT MUST BE GROUNDED IN ACCORDANCE WITH NATIONAL AND LOCAL CODES
 NOTE-FOR USE WITH COPPER CONDUCTORS ONLY REFER TO UNIT RATING PLATE FOR MINIMUM CIRCUIT AMPACITY AND MAXIMUM OVERCURRENT PROTECTION SIZE
 USED ON "M" VOLTAGE UNITS AND UNITS WITH HIGH EFFICIENCY MOTORS

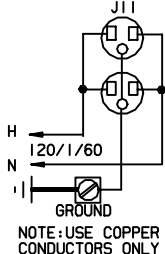

— LINE VOLTAGE FIELD INSTALLED NEC/CEC CLASS I
 NOTE-ALL REMAINING WIRES FACTORY INSTALLED

WIRING DIAGRAM 1/98	
COMBINATION PACKAGED/ROOFTOP	
LCA-088, 100-1-G, J, M, Y LGA-088, 100-1-G, J, M, Y	
HEAT/COOL SECTION B4	
Superseded Form No.	New Form No.
	532, 638W

© 1998 Lennox Industries Inc. Litho U.S.A.

LGA/LCA102-120-150 UNIT WIRING DIAGRAM

24V POWER

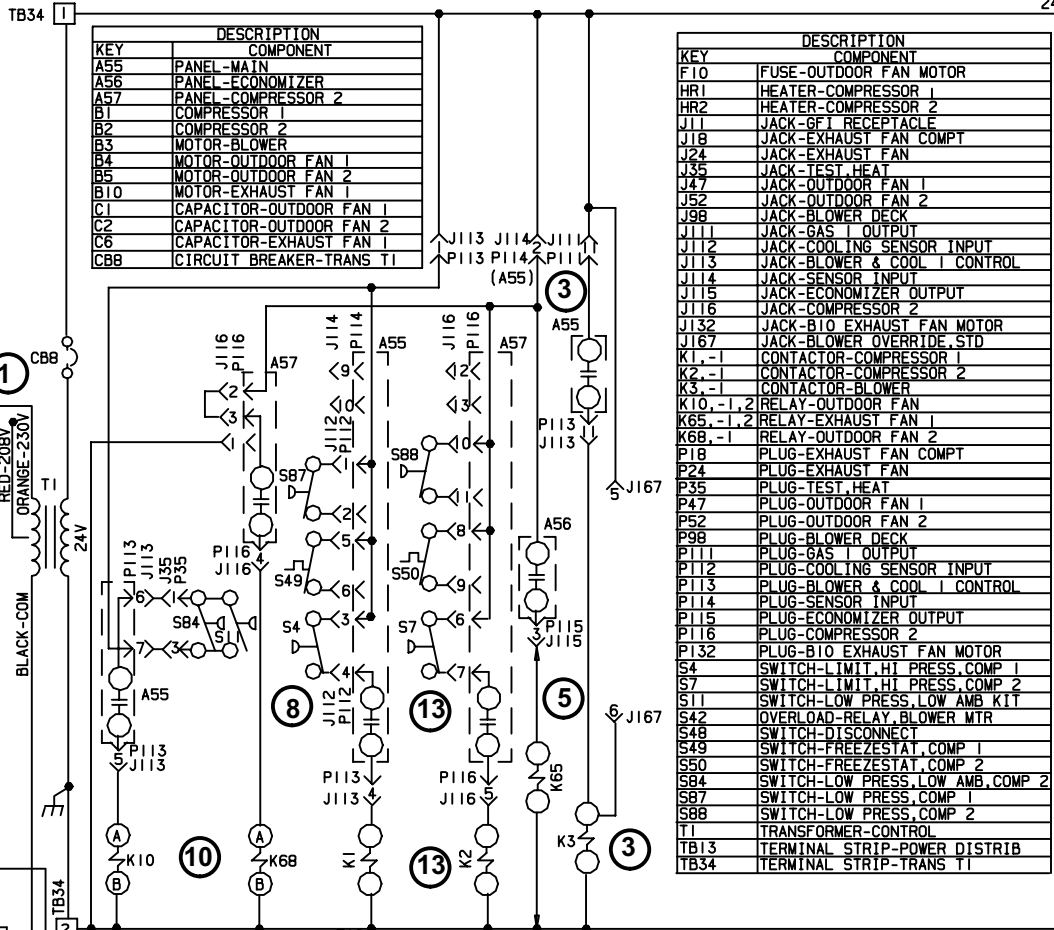

KEY	DESCRIPTION
A55	PANEL - MAIN
A56	PANEL - ECONOMIZER
A57	PANEL - COMPRESSOR 2
B1	COMPRESSOR 1
B2	COMPRESSOR 2
B3	MOTOR - BLOWER
B4	MOTOR - OUTDOOR FAN 1
B5	MOTOR - OUTDOOR FAN 2
B10	MOTOR - EXHAUST FAN 1
C1	CAPACITOR - OUTDOOR FAN 1
C2	CAPACITOR - OUTDOOR FAN 2
C6	CAPACITOR - EXHAUST FAN 1
CBB	CIRCUIT BREAKER - TRANS T1

KEY	DESCRIPTION
F10	FUSE - OUTDOOR FAN MOTOR
HR1	HEATER - COMPRESSOR 1
HR2	HEATER - COMPRESSOR 2
J11	JACK - 6F1 RECEPTACLE
J18	JACK - EXHAUST FAN COMPT
J24	JACK - EXHAUST FAN
J35	JACK - TEST HEAT
J47	JACK - OUTDOOR FAN 1
J52	JACK - OUTDOOR FAN 2
J98	JACK - BLOWER DECK
J111	JACK - GAS 1 OUTPUT
J112	JACK - COOLING SENSOR INPUT
J113	JACK - BLOWER & COOL 1 CONTROL
J114	JACK - SENSOR INPUT
J115	JACK - ECONOMIZER OUTPUT
J116	JACK - COMPRESSOR 2
J132	JACK - B10 EXHAUST FAN MOTOR
J167	JACK - BLOWER OVERRIDE, STD
K1 -	CONTACTOR - COMPRESSOR 1
K2 -	CONTACTOR - COMPRESSOR 2
K3 -	CONTACTOR - BLOWER
K10, -1, 2	RELAY - OUTDOOR FAN
K65, -1, 2	RELAY - EXHAUST FAN 1
K68, -1	RELAY - OUTDOOR FAN 2
P18	PLUG - EXHAUST FAN COMPT
P24	PLUG - EXHAUST FAN
P35	PLUG - TEST, HEAT
P47	PLUG - OUTDOOR FAN 1
P52	PLUG - OUTDOOR FAN 2
P98	PLUG - BLOWER DECK
P111	PLUG - GAS 1 OUTPUT
P112	PLUG - COOLING SENSOR INPUT
P113	PLUG - BLOWER & COOL 1 CONTROL
P114	PLUG - SENSOR INPUT
P115	PLUG - ECONOMIZER OUTPUT
P116	PLUG - COMPRESSOR 2
P132	PLUG - B10 EXHAUST FAN MOTOR
S4	SWITCH - LIMIT HI PRESS, COMP 1
S7	SWITCH - LIMIT HI PRESS, COMP 2
S11	SWITCH - LOW PRESS, LOW AMB KIT
S42	OVERLOAD - RELAY, BLOWER MTR
S48	SWITCH - DISCONNECT
S49	SWITCH - FREEZESTAT COMP 1
S50	SWITCH - FREEZESTAT COMP 2
S84	SWITCH - LOW PRESS, LOW AMB, COMP 2
S87	SWITCH - LOW PRESS, COMP 1
S88	SWITCH - LOW PRESS, COMP 2
T1	TRANSFORMER - CONTROL
TB13	TERMINAL STRIP - POWER DISTRIB
TB34	TERMINAL STRIP - TRANS T1

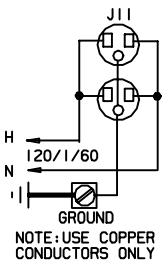
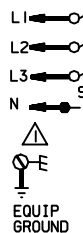
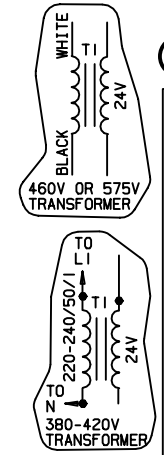

IF ANY WIRE IN THIS APPLIANCE IS REPLACED, IT MUST BE REPLACED WITH WIRE OF LIKE SIZE, RATING AND INSULATION THICKNESS

DISCONNECT ALL POWER BEFORE SERVICING THERMOSTAT HEAT ANTICIPATION SETTING 0.1 AMP

WARNING - ELECTRIC SHOCK HAZARD, CAN CAUSE INJURY OR DEATH. UNIT MUST BE GROUNDED IN ACCORDANCE WITH NATIONAL AND LOCAL CODES

NOTE - FOR USE WITH COPPER CONDUCTORS ONLY REFER TO UNIT RATING PLATE FOR MINIMUM CIRCUIT AMPACITY AND MAXIMUM OVERCURRENT PROTECTION SIZE

USED ON "M" VOLTAGE UNITS AND UNITS WITH HIGH EFFICIENCY MOTORS

← DENOTES OPTIONAL COMPONENTS

— LINE VOLTAGE FIELD INSTALLED NEC/CEC CLASS 1
 NOTE - ALL REMAINING WIRES FACTORY INSTALLED

WIRING DIAGRAM 1/98	
COMBINATION PACKAGED/ROOFTOP	
LCA, LGA-102, 120-1-G, J, M, Y LCA, LGA-150-1, 2-G, J, M, Y	
HEAT/COOL SECTION B5	
Supersedes Form No. 532,574W	New Form No. 532,739W

© 1998 Lennox Industries Inc. Litho U.S.A.

SEQUENCE OF OPERATION LGA/LCA088/100/102/120/150

Power:

1. Line voltage from unit disconnect energizes transformer T1. T1 provides 24VAC power to terminal strip TB34. TB34 provides 24VAC to the unit cooling, heating and blower controls.
2. TB13 is also energized when unit disconnect switch closes. TB13 provides line voltage to compressors crankcase heaters, compressor contactors, the blower motor contactor and condenser fan relay.

Blower Operation:

3. The main control module receives a demand from thermostat terminal G. A55 energizes blower contactor K3 with 24VAC.
4. N.O. K3-1 closes, energizing blower B3.

Economizer Operation:

5. The economizer control module A56 receives a demand and energizes exhaust fan relay K65 with 24VAC at 50% outside air damper open (adjustable).
6. N.O. K65-1 and N.O. K65-2 both close, energizing exhaust fan motor B10.

1st Stage Cooling (compressor B1)

7. First stage cooling demand energizes Y1 and G in the thermostat. G energizes blower.
8. 24VAC is routed through TB34 to the main control module A55. After A55 proves N.C. low pressure switch S87, N.C. freezestat S49 and N.C. high pressure switch S4, compressor contactor K1 is energized.
9. N.O. contacts K1-1 close energizing compressor B1.
10. N.O. low ambient switch S11 closes to energize condenser fan relay K10. LGA/LCA102/120/150 only: A57 energizes condenser fan relay K68.
11. N.O. contacts K10-1 close energizing condenser fan B4 and N.C. contacts K10-2 open, de-energizing compressor crankcase heaters HR1 and HR2. N.O. contacts K68-1 close energizing condenser fan B5.

2nd Stage Cooling (compressor B2 is energized)

12. Second stage cooling demand energizes Y2.
13. 24VAC is routed through TB34 to compressor 2 module A57. After A57 proves N.C. low pressure switch S88, N.C. freezestat S50 and N.C. high pressure switch S7, compressor contactor K2 is energized.
14. N.O. contacts K2-1 close energizing compressor B2.

LGA088/100/102/120/150 GAS HEAT UNIT WIRING DIAGRAM

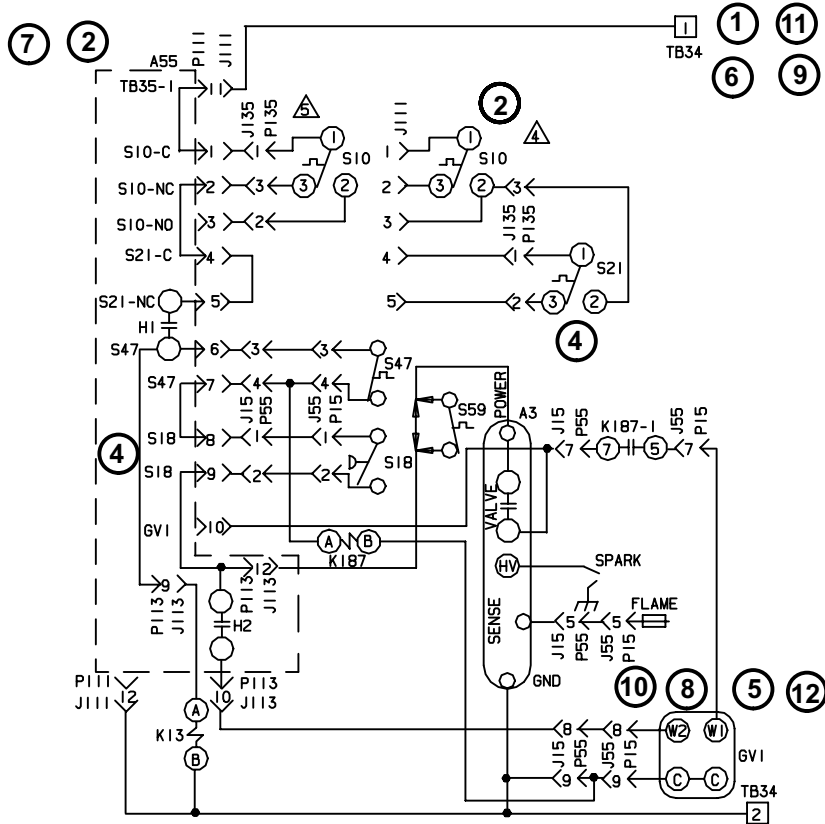

← DENOTES OPTIONAL COMPONENTS

KEY	DESCRIPTION	COMPONENT
A3	CONTROL-BURNER I	
A55	PANEL-MAIN	
B6	MOTOR-COMBUSTION AIR BLOWER I	
C3	CAPACITOR-COMB AIR BLOWER, MOTOR I	
F20	FUSE, -50C LOW AMBIENT KIT	
GV1	VALVE-GAS I	
HR6	HEATER, -50C LOW AMBIENT KIT	
J1	JACK-GAS LIMIT	
J15	JACK-GAS	
J55	JACK	
J111	JACK-GAS I, OUTPUT	
J113	JACK-BLOWER & COOL I CONTROL	
J135	JACK	
K13, -I	RELAY-COMBUSTION AIR BLOWER	
K187, -I	RELAY-ISOLATION	
P1	PLUG-GAS LIMIT	
P15	PLUG-GAS	
P55	PLUG	
P111	PLUG-GAS I, OUTPUT	
P113	PLUG-BLOWER & COOL I CONTROL	
P135	PLUG	
S10	SWITCH-LIMIT, PRIMARY GAS	
S18	SWITCH-COMB AIR BLOWER, PROVE	
S21	SWITCH-LIMIT, SECONDARY GAS HEAT	
S47	SWITCH-FLAME ROLLOUT, BURNER I	
S59	THERMOSTAT, -35 C OPEN, -50 C	
S60	THERMOSTAT, -23C CL, -7C OP, -50C LOW AMB KIT	
S61	THERMOSTAT, +24C OPEN, -50C LOW AMB KIT	
T3	TRANSFORMER-COMB AIR BLOWER I	
T20	TRANSFORMER, -50C LOW AMBIENT KIT	
TB34	TERMINAL STRIP-TRANSFORMER T1	
TB35	TERMINAL STRIP-TRANSFORMER T18	

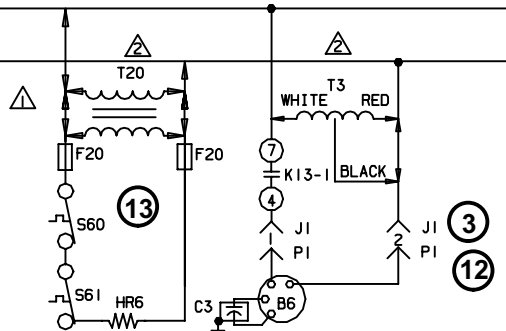

- △ CGA(-50C)LOW AMBIENT KIT (OPTIONAL)
- △ T3 & T20 USED ON 460V & 575V UNITS ONLY
- △ USED ON 6 TON AND SMALLER UNITS
- △ S10, S21 HOOKUP FOR 036 TO 072 UNITS
- △ S10 HOOKUP FOR 090 TO 150 UNITS

WIRING DIAGRAM		7/98
COMBINATION UNIT-ROOFTOP		
GAS HEAT FOR		
"L" SERIES, 75 THRU 235 UNITS		
(A+ AND B BOX)		
HEATING SECTION-A1		
Supersedes Form No.	New Form No.	
532,034W	532,902W	

©1998 Lennox Industries Inc. Litho U.S.A.

SEQUENCE OF OPERATION LGA088/100/102/120/150

First Stage Heat:

1. Heating demand initiates at W1 in the thermostat.
2. 24VAC is routed through TB34 to the main control module A55. After A55 proves N.C. primary limit S21, the combustion air blower relay K13 is energized.
3. N.O. K13-1 contacts close allowing line voltage to energize combustion air blower B6.
4. After the combustion air blower B6 has reached full speed, the combustion air proving switch S18 contacts close. The A55 routes 24VAC through N.C. burner flame rollout switch S47 and the closed contacts of combustion air proving switch S18 to energize the ignition module A3.
5. After a 30 second delay A3 energizes the ignitor and W1 terminal (low fire) of gas valve GV1.

Second Stage Heat:

6. With first stage heat operating, an additional heating demand initiates W2 in the thermostat.
7. A second stage heating demand is received by A55 control module.

8. A55 energizes W2 terminal (high fire) of gas valve GV1.

End of Second Stage Heat:

9. Heating demand is satisfied. Terminal W2 (high fire) is de-energized.
10. Terminal W2 of GV1 is de-energized by A55 control module.

End of First Stage Heat:

11. Heating demand is satisfied. Terminal W1 (low fire) is de-energized.
12. Ignition A3 is de-energized by control module A55 in turn de-energizing terminal W1 of GV1. Combustion air blower relay K13 is also de-energized.

Optional Low Ambient Kit:

(C.G.A. -50°C Low Ambient Kit)

13. Line voltage (or transformer T20 in 460V and 575V only) is routed through the low ambient kit fuses F20 and N.C. low ambient kit thermostats S60 and S61, to energize low ambient kit heater HR6.

LHA088 UNIT WIRING SCHEMATIC

24V POWER

TB34

IF ANY WIRE IN THIS APPLIANCE IS REPLACED IT MUST BE REPLACED WITH WIRE OF LIKE SIZE, RATING AND INSULATION THICKNESS

DISCONNECT ALL POWER BEFORE SERVICING

NOTE-FOR USE WITH COPPER CONDUCTORS ONLY, REFER TO UNIT RATING PLATE FOR MINIMUM CIRCUIT AMPACITY AND MAXIMUM OVERCURRENT PROTECTION SIZE

KEY	DESCRIPTION
A55	PANEL-MAIN
A56	PANEL-ECONOMIZER
B1	COMPRESSOR
B3	MOTOR-BLOWER
B4	MOTOR-OUTDOOR FAN
B10	MOTOR-EXHAUST FAN
C1	CAPACITOR-OUTDOOR FAN
C4	CAPACITOR-BLOWER MOTOR
C6	CAPACITOR-EXHAUST FAN
CBB	CIRCUIT BREAKER-TRANS T1
HR1	HEATER-COMPRESSOR
J11	JACK-GFI RECEPTACLE
J18	JACK
J24	JACK-EXHAUST FAN
J39	JACK-MOTOR SPEED CHANGE
J43	JACK-BLOWER MOTOR
J47	JACK-OUTDOOR FAN
J98	JACK-BLOWER DECK
J111	JACK-GAS I OUTPUT
J112	JACK-COOLING SENSOR INPUT
J113	JACK-BLOWER & COOL I CONTROL
J114	JACK-SENSOR INPUT
J115	JACK-ECONOMIZER OUTPUT
J132	JACK-BLOWER EXHAUST FAN MTR
J167	JACK-BLOWER OVERRIDE STD
K1	CONTACTOR-COMPRESSOR
K3	CONTACTOR-BLOWER
K10	RELAY-OUTDOOR FAN
K58	RELAY-LOW AMBIENT KIT
K65	RELAY-EXHAUST FAN
L1	VALVE-REVERSING
P18	PLUG
P24	PLUG-EXHAUST FAN
P39	PLUG-MOTOR SPEED CHANGE
P43	PLUG-BLOWER MOTOR
P47	PLUG-OUTDOOR FAN
P98	PLUG-BLOWER DECK
P111	PLUG-GAS I OUTPUT
P112	PLUG-COOLING SENSOR INPUT
P113	PLUG-BLOWER & COOL I CONTROL
P114	PLUG-SENSOR INPUT
P115	PLUG-ECONOMIZER OUTPUT
P132	PLUG-BLOWER, EXHAUST FAN MTR
S4	SWITCH-LIMIT, HI PRESS
S5	SWITCH-LIMIT, HI TEMP, COMP I
S11	SWITCH-LOW PRESS, LOW AMB KIT
S6	SWITCH-DEFROST, COMPRESSOR

24V COMMON

KEY	DESCRIPTION
S42	OVERLOAD-RELAY, BLOWER MOTOR
S46	SWITCH-DEFROST TERMINATION
S48	SWITCH-DISCONNECT
S49	SWITCH-FREEZESTAT, COMP I
S87	SWITCH-LOW PRESS, COMP I
T1	TRANSFORMER-CONTROL
T4	TRANSFORMER-BLOWER MOTOR
TB13	TERMINAL STRIP-POWER DISTRIB
TB34	TERMINAL STRIP-TRANS T1

△ S42 USED ON "M" VOLTAGE UNITS AND UNITS WITH HIGH EFFICIENCY MOTORS

△ IF EITHER S4 OR S5 OPEN, READ THE DIAGNOSTIC CODE FOR S4

— LINE VOLTAGE FIELD INSTALLED
NEC/CEC CLASS II

NOTE-ALL REMAINING WIRE FACTORY INSTALLED
← DENOTES OPTIONAL COMPONENTS

WIRING DIAGRAM 3/98	
HEAT PUMP-PACKAGED	
LHA-088-1-G, J, M, Y	
HEAT PUMP SECTION B11	
Supersedes Form No.	New Form No.
	532,639W

© 1998 Lennox Industries Inc.

Litho U.S.A.

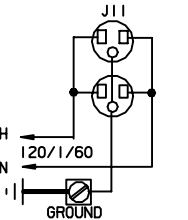
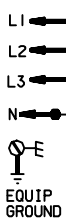
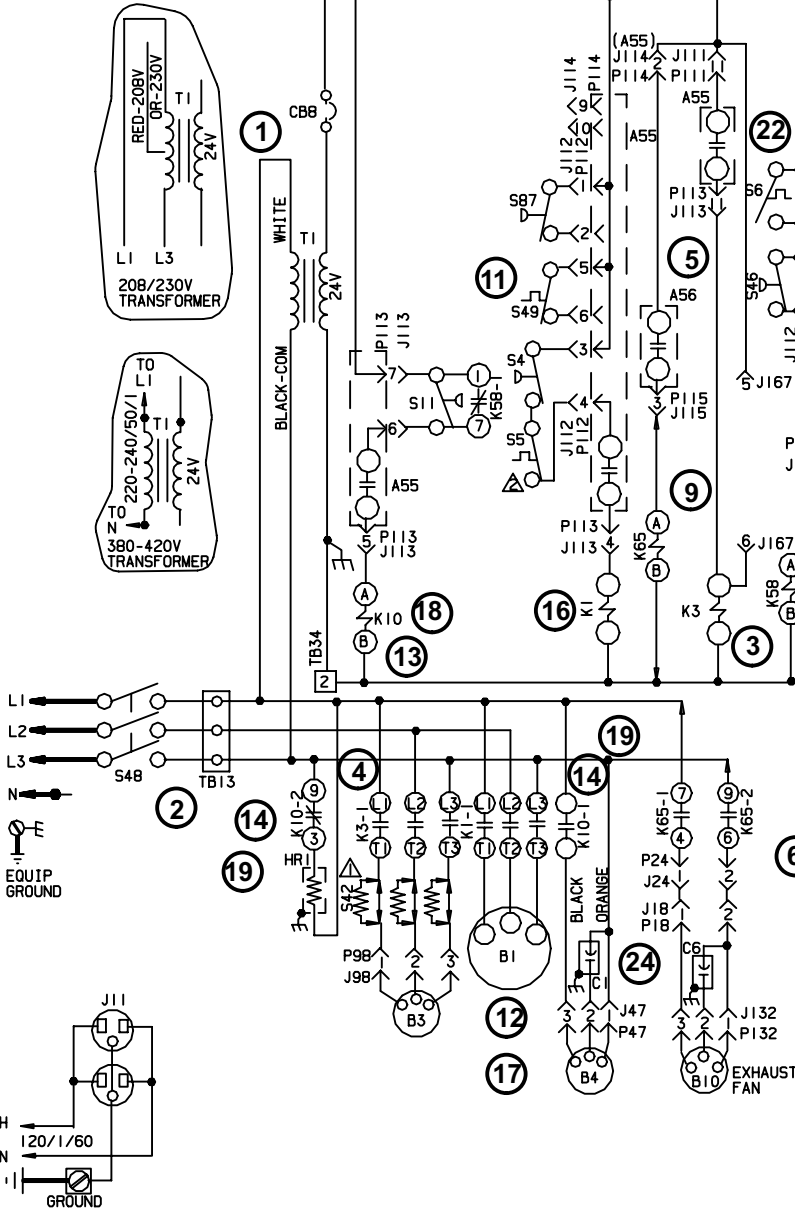

NOTE-USE COPPER CONDUCTORS ONLY
120V F FIELD PROVIDED
POWER SUPPLY IS
REQUIRED WHEN T29
15 NOT PROVIDED

THERMOSTAT HEAT ANTICIPATION
SETTING 0.1 AMP

WARNING-ELECTRIC SHOCK HAZARD CAN
CAUSE INJURY OR DEATH. UNIT
MUST BE GROUNDED IN ACCORDANCE
WITH NATIONAL AND LOCAL CODES

SEQUENCE OF OPERATION LHA088

Power:

1. Line voltage from unit disconnect energizes transformer T1. T1 provides 24VAC power to terminal strip TB34, which provides 24VAC to the unit cooling, heating and blower controls and thermostat.
2. Terminal TB13 is also energized when unit disconnect switch closes. TB13 provides line voltage to compressor crankcase heater, compressor contactor, the blower motor contactor and condenser fan relay.

Blower Operation:

3. The main control module receives a demand from thermostat terminal G. A55 energizes blower contactor K3 with 24VAC.
4. N.O. K3-1 closes, energizing blower B3.

Economizer Operation:

5. The economizer control module A56 receives a demand and energizes exhaust fan relay K65 with 24VAC at 50% outside air damper open (adjustable).
6. N.O. K65-1 and N.O. K65-2 both close, energizing exhaust fan motor B10.

Cooling Demand:

7. First stage cooling demand energizes Y1 and G in the thermostat. G energizes blower (see step 3).
8. 24VAC is routed through TB34 to the main control module A55.
9. A55 proves N.O. defrost switch S6 and N.C. defrost termination switch S46 to energize reversing valve L1 and low ambient relay K58.
10. N.C. contacts K58-1 open, giving control of K10 fan relay to low ambient pressure switch S11.
11. A55 proves N.C. low pressure switch S87, N.C. freeze stat S49 and N.C. high pressure switch S4 to energize compressor contactor K1.
12. N.O. contacts K1-1 close energizing compressor B1.
13. 24VAC is routed through N.O. low ambient pressure switch S11 (now closed) and N.C. low ambient contact K58-1 (now open) to energize outdoor fan contactor K10.
14. N.O. contacts K10-1 close energizing outdoor fan B4 and N.C contacts K10-2 open de-energizing crankcase heater HR1.

First Stage Heat:

15. Heating demand energizes W1 in the thermostat.
16. 24VAC is routed through TB34 to the main control module A55. After A55 proves N.C. low pressure switch S87, N.C. high temperature limit S5, N.C. freeze stat S49 and N.C. high pressure switch S4, compressor contactor K1 is energized.

NOTE: On first heating demand after unit has been in cooling mode, module A55 will de-energize reversing valve L1 and low ambient relay K58. K58-1 N.C. contacts will take control away from low ambient pressure switch S11.

17. N.O. contactor K1-1 closes energizing compressor B1.
18. 24VAC from the main control module A55 is routed through N.C. low ambient contact K58-1 to energize outdoor fan contactor K10.
19. N.O. contacts K10-1 close energizing outdoor fan B4 and N.C contacts K10-2 open, de-energizing compressor crankcase heater HR1.

Second Stage Heat (electric heat):

20. Second stage heat demand energizes W2 in the thermostat.
21. See sequence of operation for electric heat.

Defrost Mode:

22. During heating operation, when outdoor coil drops to $35 \pm 4^\circ$ the defrost thermostat S6 closes initiating defrost (after minimum run time of 30, 60 or 90 minutes).
23. When defrost begins, the reversing valve L1 is energized. Supplemental electric heat is energized.
24. When L1 energizes, N.C. K58-1 contacts open de-energizing outdoor fan relay K10, followed by outdoor fan B4.
25. Defrost terminates when pressure switch S46 opens, or when 15 minutes has elapsed. The defrost cycle is **not** terminated when thermostat demand ends.

LHA090/120 UNIT WIRING SCHEMATIC

24V POWER

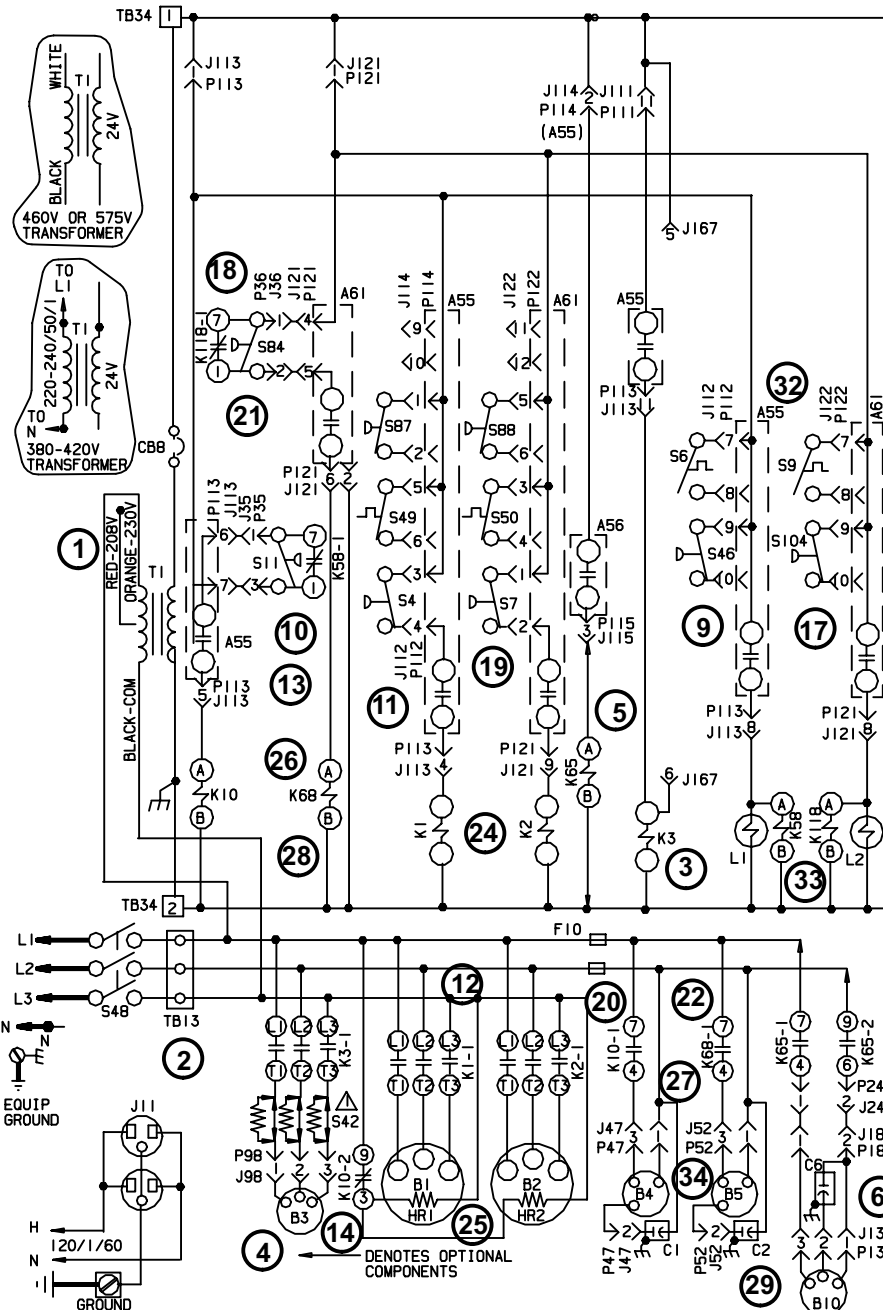

KEY	DESCRIPTION
A55	PANEL-MAIN
A56	PANEL-ECONOMIZER
A61	PANEL-HEAT PUMP
B1	COMPRESSOR 1
B2	COMPRESSOR 2
B3	MOTOR-BLOWER
B4	MOTOR-OUTDOOR FAN 1
B5	MOTOR-OUTDOOR FAN 2
B10	MOTOR-EXHAUST FAN
C1	CAPACITOR-OUTDOOR FAN 1
C2	CAPACITOR-OUTDOOR FAN 2
C6	CAPACITOR-EXHAUST FAN
CB8	CIRCUIT BREAKER-TRANS T1
F10	FUSE-OUTDOOR FAN MOTOR
HR1	HEATER-COMPRESSOR 1
HR2	HEATER-COMPRESSOR 2
J11	JACK-GET RECEPTACLE
J12	JACK-EXHAUST FAN COMPT
J24	JACK-EXHAUST FAN
J35	JACK-TEST HEAT
J36	JACK-TEST COOL
J47	JACK-OUTDOOR FAN 1
J52	JACK-OUTDOOR FAN 2
J98	JACK-BLOWER DECK
J111	JACK-GAS 1 OUTPUT
J112	JACK-COOLING SENSOR INPUT
J113	JACK-BLOWER & COOL 1 CONTROL
J114	JACK-SENSOR INPUT
J115	JACK-ECONOMIZER OUTPUT
J121	JACK-HEAT PUMP CONTROL
J122	JACK-HEAT PUMP INPUT
J132	JACK-B10 EXHAUST FAN MOTOR
J167	JACK-BLOWER OVERRIDE, STD
K1 -1	CONTACTOR-COMPRESSOR 1
K2 -1	CONTACTOR-COMPRESSOR 2
K3 -1, 2	CONTACTOR-BLOWER
K10 -1, 2	RELAY-OUTDOOR FAN 1
K65 -1, 2	RELAY-LOW AMBIENT KIT
K65 -1, 2	RELAY-EXHAUST FAN
K68 -1	RELAY-OUTDOOR FAN 2
K118 -1	RELAY-LOW AMBIENT KIT, COMP 2
L1	VALVE-REVERSING 1
L2	VALVE-REVERSING 2
P18	PLUG-EXHAUST FAN 2
P24	PLUG-EXHAUST FAN
P35	PLUG-TEST HEAT
P36	PLUG-TEST COOL
P47	PLUG-OUTDOOR FAN 1
P52	PLUG-OUTDOOR FAN 2
P98	PLUG-BLOWER DECK
P111	PLUG-GAS 1 OUTPUT
P112	PLUG-COOLING SENSOR

KEY	DESCRIPTION
P113	PLUG-BLWR & COOL 1 CONT
P114	PLUG-SENSOR INPUT
P115	PLUG-ECONOMIZER OUTPUT
P116	PLUG-COMPRESSOR 2
P121	JACK-HEAT PUMP CONTROL
P122	JACK-HEAT PUMP INPUT
P132	PLUG-B10 EXHAUST FAN MOTOR
S4	SWITCH-LIMIT, HI PRESS, COMP 1
S6	SWITCH-DEFROST, COMP 1
S7	SWITCH-LIMIT, HI PRESS, COMP 2
S9	SWITCH-DEFROST, COMP 2
S11	SWITCH-LOW PRESS, LOW AMB KIT
S42	OVERLOAD-RELAY, BLWR MOTOR
S46	SWITCH-DEFROST TERMINATION
S48	SWITCH-DISCONNECT
S49	SWITCH-FREEZE STAT, COMP 1
S50	SWITCH-FREEZE STAT, COMP 2
S84	SWITCH-LOW PRESS, LOW AMB, COMP 2
S87	SWITCH-LOW PRESS, COMP 1
S88	SWITCH-LOW PRESS, COMP 2
S104	SWITCH-DEFROST PRESS, COMP 2
T1	TRANSFORMER-CONTROL
TB13	TERMINAL STRIP-POWER DISTRIB
TB34	TERMINAL STRIP-TRANS T1

NOTE: USE COPPER CONDUCTORS ONLY

IF ANY WIRE IN THIS APPLIANCE IS REPLACED, IT MUST BE REPLACED WITH WIRE OF LIKE SIZE, RATING AND INSULATION THICKNESS
 DISCONNECT ALL POWER BEFORE SERVICING
 NOTE-FOR USE WITH COPPER CONDUCTORS ONLY
 REFER TO UNIT RATING PLATE FOR MINIMUM CIRCUIT AMPACITY AND MAXIMUM OVERCURRENT PROTECTION SIZE
 THERMOSTAT HEAT ANTICIPATION SETTING 0.1 AMP
 WARNING-ELECTRIC SHOCK HAZARD, CAN CAUSE INJURY OR DEATH. UNIT MUST BE GROUNDED IN ACCORDANCE WITH NATIONAL AND LOCAL CODES
 LINE VOLTAGE FIELD INSTALLED NEC/CEC CLASS 1
 NOTE-ALL REMAINING WIRES FACTORY INSTALLED

WIRING DIAGRAM		3/98
HEAT PUMP-PACKAGED		
LHA-090, 120-1-G, J, M, Y		
HEAT PUMP SECTION B14		
Supersedes Form No.	New Form No.	
532, 640W	532, 788W	
© 1998 Lennox Industries Inc.		Litho U.S.A.

SEQUENCE OF OPERATION LHA090/120

Power:

1. Line voltage from unit disconnect energizes transformer T1. T1 provides 24VAC power to terminal strip TB34, which provides 24VAC to the unit cooling, heating and blower controls and thermostat.
2. Terminal TB13 is also energized when unit disconnect switch closes. TB13 provides line voltage to compressor crankcase heater, compressor contactor, the blower motor contactor and condenser fan relay.

Blower Operation:

3. The main control module receives a demand from thermostat terminal G. A55 energizes blower contactor K3 with 24VAC.
4. N.O. K3-1 closes, energizing blower B3.

Economizer Operation:

5. The economizer control module A56 receives a demand and energizes exhaust fan relay K65 with 24VAC at 50% outside air damper open (adjustable).
6. N.O. K65-1 and N.O. K65-2 both close, energizing exhaust fan motor B10.

First Stage Cooling Demand (compressor B1)

7. First stage cooling demand energizes Y1 and G in the thermostat. G energizes blower (see step 3).
8. 24VAC is routed through TB34 to the main control module A55.
9. A55 proves N.O. defrost switch S6 and N.C. defrost termination switch S46 to energize reversing valve L1 and low ambient relay K58.
10. N.C. contacts K58-1 open, giving control of K10 fan relay to low ambient pressure switch S11.
11. A55 proves N.C. low pressure switch S87, N.C. freeze stat S49 and N.C. high pressure switch S4 to energize compressor contactor K1.
12. N.O. contacts K1-1 close energizing compressor B1.
13. 24VAC is routed through N.O. low ambient pressure switch S11 (now closed) and N.C. low ambient contact K58-1 (now open) to energize outdoor fan contactor K10.
14. N.O. contacts K10-1 close energizing outdoor fan B4 and N.C contacts K10-2 open de-energizing crankcase heaters HR1 and HR2..

Second Stage Cooling Demand (compressor B2)

15. Second stage cooling demand energizes Y2 and G in the thermostat. G energizes blower (see step 3).
16. 24VAC is routed through TB34 to the heat pump control module A61.
17. Heat pump control A61 proves N.O. defrost switch S9 and N.C. defrost termination switch S46 to energize reversing valve L2 and low ambient relay K118.
18. N.C. contacts K118-1 open, giving control of K68 fan relay to low ambient pressure switch S84.

19. A61 proves N.C. low pressure switch S87, N.C. freeze stat S50 and N.C. high pressure switch S7 to energize compressor contactor K2.

20. N.O. contacts K2-1 close energizing compressor B2.
21. 24VAC is routed through N.O. low ambient pressure switch S84 (now closed) to energize outdoor fan contactor K68.
22. N.O. contacts K68-1 close energizing outdoor fan B5.

First Stage Heat (compressors B1 and B2)

23. Heating demand energizes W1 in the thermostat.
24. 24VAC is routed through TB34 to the main control module A55 and heat pump control A61. After A55 and A61 proves N.C. high pressure switch S4 and S7, compressor contactor K1 and K2 are energized.

NOTE: On first heating demand after unit has been in cooling mode, module A55 and A61 will de-energize reversing valve L1 and L2 and low ambient relay K58 and K118. K58-1 and K118-1 N.C. contacts will take control away from low ambient pressure switches S11 and S84.

25. N.O. contacts K1-1 and K2-1 close energizing compressor B1 and B2.
26. 24VAC from the main control module A55 is routed through N.C. low ambient contact K58-1 to energize outdoor fan contactor K10.
27. N.O. contacts K10-1 close energizing outdoor fan B4 and N.C contacts K10-2 open, de-energizing compressor crankcase heater HR1.
28. 24VAC from heat pump control A61 is routed through N.C. low ambient contact to energize outdoor fan relay K68.
29. N.O. contacts K68-1 close energizing outdoor fan B5.

Second Stage Heat (electric heat):

30. Second stage heat demand energizes W2 in the thermostat.
31. See sequence of operation for electric heat.

Defrost Mode:

32. During heating operation, when outdoor coil drops to $35 \pm 4^\circ$ the defrost thermostat S6 or S9 closes initiating defrost (after minimum run time of 30, 60 or 90 minutes).
33. When defrost begins, the reversing valve L1 or L2 is energized. Supplemental electric heat is energized.
34. When L1 energizes, N.C. K58-1 contacts open de-energizing outdoor fan relay K10, followed by outdoor fan B4. When L2 energizes N.C. K118-1 contacts open de-energizing outdoor fan relay K68, followed by outdoor fan B5.
35. Defrost terminates when the pressure switch for the circuit S46 or S104 opens, or when 15 minutes has elapsed. The defrost cycle is **not** terminated when thermostat demand ends.

C2 diagram ELECTRONIC OR ELECTROMECHANICAL THERMOSTAT

24V POWER

①

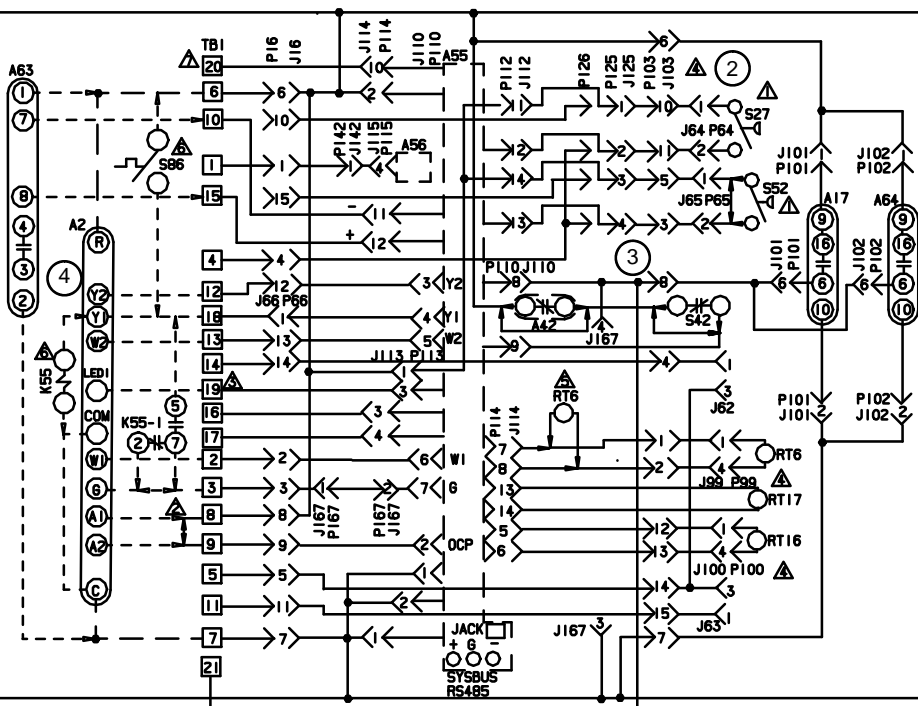

24V COMMON

KEY	DESCRIPTION
A2	SENSOR-ELECTRONIC
A17	DETECTOR-SMOKE
A42	MONITOR-PHASE PROTECTION
A55	PANEL-MAIN
A56	PANEL-ECONOMIZER
A63	SENSOR-CO2(LAO)
A64	DETECTOR-SMOKE,SUPPLY AIR
J16	JACK-UNIT
J62	JACK-A2 RETURN AIR SENSOR
J63	JACK-RT1 DISCH. AIR SENSOR
J64	JACK-S27 FILTER SWITCH
J65	JACK-S52 FAN SWITCH
J66	JACK-COOL I INTERFACE
J69	JACK-DISCHARGE TEMP SENSOR
J100	JACK-RETURN TEMP SENSOR
J101	JACK-SMOKE DETECTOR,RETURN AIR
J102	JACK-SMOKE DETECTOR,SUPPLY AIR
J103	JACK-SENSORS CONTROL
J110	JACK-THERMOSTAT INPUT
J112	JACK-COOLING SENSOR INPUT
J113	JACK-BLOWER & COOL I CONTROL
J114	JACK-SENSOR INPUT
J115	JACK-ECONOMIZER OUTPUT
J125	JACK-BLOWER PROVING
J126	JACK-JUMPER,BLOWER PROVING
J142	JACK-ECONOMIZER HARNESS
J167	JACK-BLOWER OVERRIDE STD
K27-I	RELAY-TRANSFER 2
K55-I	RELAY-TWO
P18	PLUG-UNIT
P84	PLUG-S27 FILTER SWITCH
P65	PLUG-S50 FAN SWITCH
P66	PLUG-COOL ONE
P99	PLUG-DISCHARGE TEMP SENSOR
P100	PLUG-RETURN TEMP SENSOR
P101	PLUG-SMOKE DETECTOR,RETURN AIR
P102	PLUG-SMOKE DETECTOR,SUPPLY AIR

KEY	DESCRIPTION
P103	PLUG-SENSORS CONTROL
P110	PLUG-THERMOSTAT INPUT
P112	PLUG-COOLING SENSOR INPUT
P113	PLUG-BLOWER & COOL I CONTROL
P114	PLUG-SENSOR INPUT
P115	PLUG-ECONOMIZER OUTPUT
P125	PLUG-BLOWER PROVING
P126	PLUG-JUMPER,BLOWER PROVING
P142	PLUG-ECONOMIZER HARNESS
P167	PLUG-BLOWER OVERRIDE STD
RT6	SENSOR-A55 DISCHARGE (IMC)
RT16	SENSOR-RETURN AIR TEMP
RT17	SENSOR-OUTSIDE AIR TEMP
S27	SWITCH-FILTER
S42	OVERLOAD-RELAY,BLOWER MOTOR
S52	SWITCH-AIR FLOW
S56	SWITCH-DEHUMIDISTAT RSF8601
TB1	TERMINAL STRIP-24V CLASS II

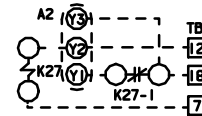

THERMOSTAT HOOKUP FOR SELECTABLE OPTION #3, ECTO 5.04 ON M1-5 IMC BOARD (A55)

TO PROVIDE THREE COMPRESSOR STAGES. REQUIRES 3 HEAT, 3 COOL THERMOSTAT AND K27 RELAY

- ▲ S27 AND S52 ARE OPTIONAL
- ▲ REMOVE JUMPER WHEN OCCUPIED-UNOCCUPIED OPERATION IS DESIRED. UNIT REMAINS IN OCCUPIED OPERATION WITH JUMPER
- ▲ TBI-19 IS SERVICE RELAY OUTPUT (24VAC). IF USED CONNECT TO AN INDICATOR LIGHT OR RELAY COIL (MAX 4VA)
- ▲ J99/P99, J100/P100 AND J103/P103 ARE NOT USED ON-036,042,048,060,072,088 AND 100 UNITS
- ▲ ALTERNATE REMOTE LOCATION OF RT6
- ▲ USE S86 DEHUMIDISTAT AND K55 RELAY FOR OPTIONAL REHEAT SCHEME. SET PARAMETER 4.24 TO CONTROL VALVE I FOR SIMULTANEOUS HEATING AND COOLING
- ▲ TBI-20 FOR DEHUMIDIFICATION CONTROL

————— DESIGNATES OPTIONAL WIRING
- - - - - CLASS II FIELD WIRING

WIRING DIAGRAM	1/01
ACCESSORIES	
ELECTRONIC OR ELECTROMECHANICAL THERMOSTAT FOR "L" SERIES UNITS	
TEMPERATURE CONTROL SECTION C2	
Supersedes Form No. 532, 583W	New Form No. 533, 629W
© 2001 Litho U.S.A.	

SEQUENCE OF OPERATION

C2 DIAGRAM - ELECTRONIC OR ELECTROMECHANICAL THERMOSTAT

POWER:

- Terminal strip TB34 energizes the thermostat components with 24VAC via TB1.

OPERATION:

- The main control module A55 proves the optional N.O. filter switch S27(indicates dirty filter when closed), optional N.O. air flow switch S52(indicates no air [i.e. broken belt] system shuts down), and optional C.G.A. -50°C low ambient kit thermostat S59 (used in C.G.A. units only).
- The main control module A55 receives data from the supply and return smoke detectors A17 and A64, optional phase protection monitor A42, blower motor overload relay S42, discharge sensor RT6, return air sensor RT16, and the outdoor air sensor RT17.
- The main control module A55 receives data from the electronic thermostat A2 (Y1, Y2, W1, W2, G, OCP) and the CO₂ sensor (if economizer is used) via terminal strip TB1. A55 energizes the appropriate components.

"L" SERIES ECONOMIZER

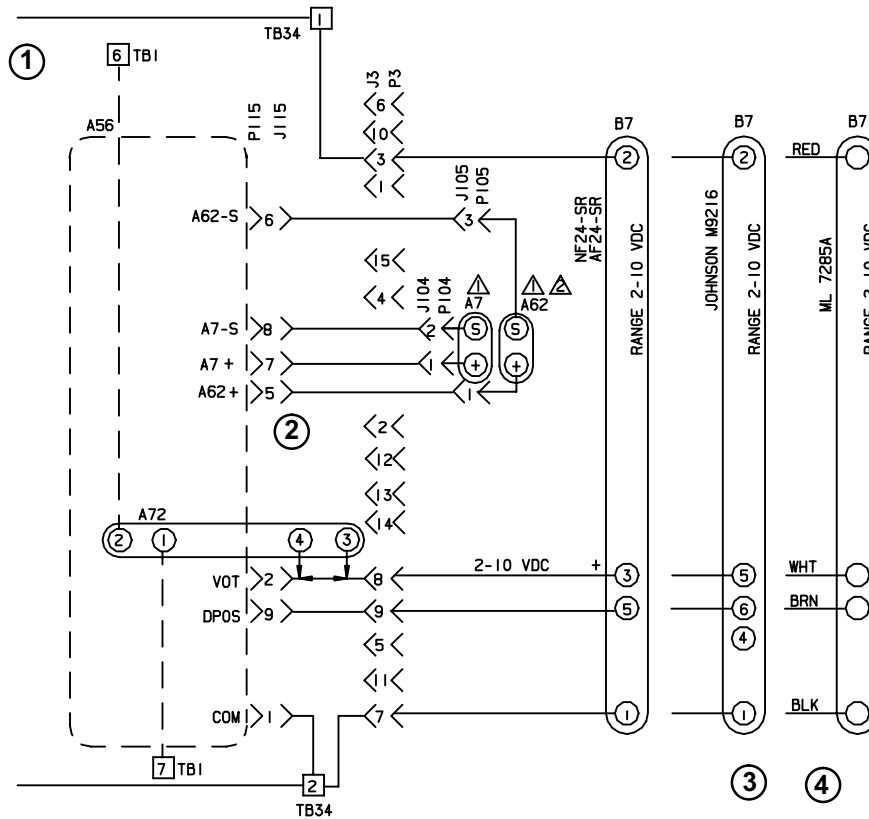

- △ DELETE A7 AND A62 (IF USED) FOR EITHER GLOBAL ENTHALPY OR SENSIBLE TEMPERATURE CONTROL
- △ FOR UNIT DIFFERENTIAL ENTHALPY CONTROL, ADD A62 RETURN AIR ENTHALPY SENSOR

NOTE: THIS DIAGRAM USED ONLY WHEN ECONOMIZER OR MOTORIZED OUTDOOR AIR DAMPERS ARE INSTALLED

WIRING DIAGRAM 8/97	
ACCESSORIES	
"L" SERIES ECONOMIZER AND MOTORIZED OUTSIDE AIR DAMPER	
ECONOMIZER-SECTION D1	
Supersedes Form No.	New Form No.
531,713W	531,770W

©1997 Lennox Industries Inc.

Litho U.S.A.

KEY	DESCRIPTION
A7	SENSOR-SOLID STATE ENTHALPY
A56	PANEL-ECONOMIZER
A62	SENSOR-ENTHALPY, INDOOR
A72	CONTROL-REMOTE, MIN POS(OPT)
B7	MOTOR-DAMPER
J3	JACK-UNIT ECONOMIZER
J104	JACK-SENSOR, OUTDOOR ENTHALPY
J105	JACK-SENSOR, RETURN AIR ENTHALPY
J115	JACK-ECONOMIZER, OUTPUT
P3	PLUG-UNIT ECONOMIZER
P104	PLUG-SENSOR, OUTDOOR ENTHALPY
P105	PLUG-SENSOR, RETURN AIR ENTHALPY
P115	PLUG-ECONOMIZER, OUTPUT
TB1	TERMINAL STRIP-CLASS II VOLTAGE
TB34	TERMINAL STRIP-TRANSFORMER TI

SEQUENCE OF OPERATION "L" SERIES ECONOMIZER

POWER:

1. Terminal strip TB34 energizes the economizer components with 24VAC.

OPERATION:

2. The main control module A55 along with outdoor enthalpy sensor A7 and indoor enthalpy sensor A62 (if differential enthalpy is used) communicates to the economizer control module A56 when to power the damper motor B7.
3. The economizer control module A56 supplies B7 with 0 - 10 VDC to control the positioning of economizer.
4. The damper actuator provides 2 to 10 VDC position feedback.

EHA-7.5, 15, 22.5, 30kW Y VOLTAGE

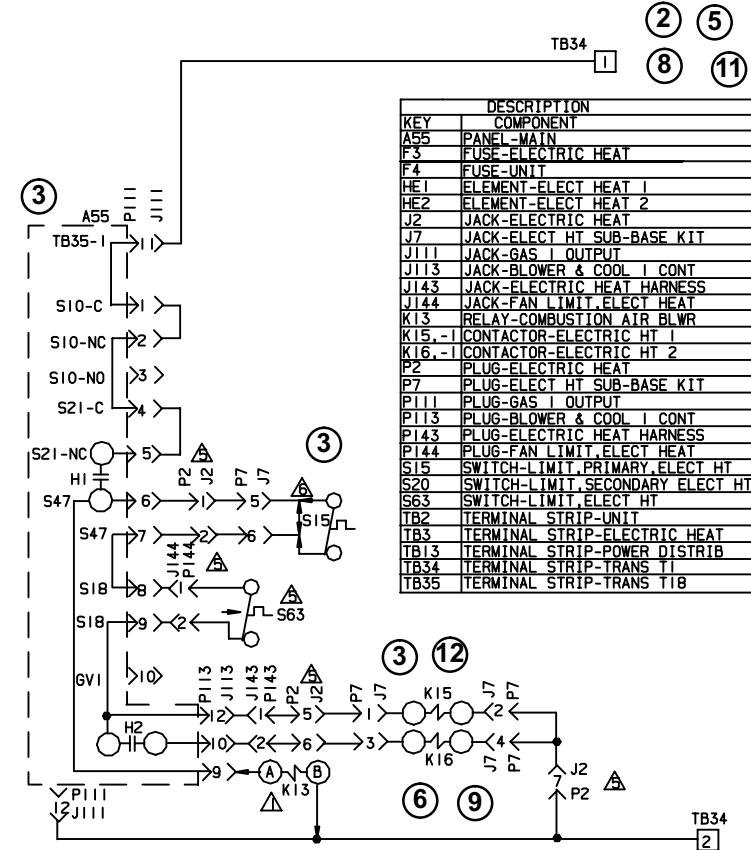

KEY	DESCRIPTION
A55	PANEL-MAIN
F3	FUSE-ELECTRIC HEAT
F4	FUSE-UNIT
HE1	ELEMENT-ELECT HEAT 1
HE2	ELEMENT-ELECT HEAT 2
J2	JACK-ELECTRIC HEAT
J7	JACK-ELECT HT SUB-BASE KIT
J111	JACK-GAS I OUTPUT
J113	JACK-BLOWER & COOL I CONT
J143	JACK-ELECTRIC HEAT HARNESS
J144	JACK-FAN LIMIT,ELECT HEAT
K13	RELAY-COMBUSTION AIR BLWR
K15,-1	CONTACTOR-ELECTRIC HT 1
K16,-1	CONTACTOR-ELECTRIC HT 2
P2	PLUG-ELECTRIC HEAT
P7	PLUG-ELECT HT SUB-BASE KIT
P111	PLUG-GAS I OUTPUT
P113	PLUG-BLOWER & COOL I CONT
P143	PLUG-ELECTRIC HEAT HARNESS
P144	PLUG-FAN LIMIT,ELECT HEAT
S15	SWITCH-LIMIT,PRIMARY ELECT HT
S20	SWITCH-LIMIT,SECONDARY ELECT HT
S63	SWITCH-LIMIT,ELECT HT
TB2	TERMINAL STRIP-UNIT
TB3	TERMINAL STRIP-ELECTRIC HEAT
TB13	TERMINAL STRIP-POWER DISTRIB
TB34	TERMINAL STRIP-TRANS T1B
TB35	TERMINAL STRIP-TRANS T1B

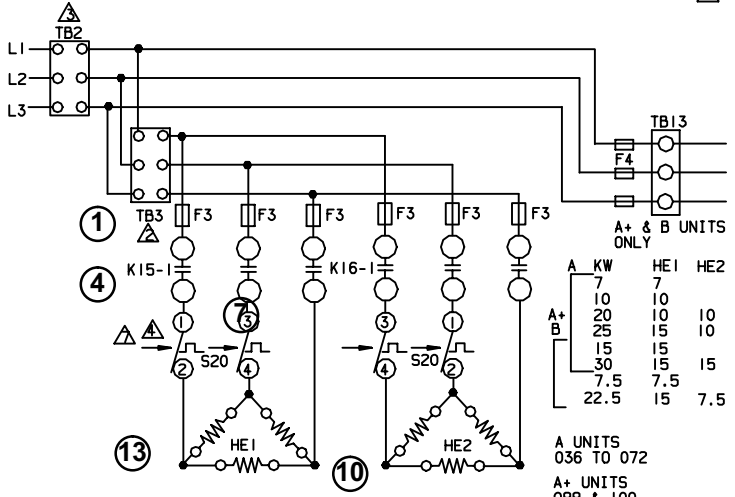

- ⚠ S20 LIMIT ON "A" BOX IS NOT RESETTABLE
- ⚠ REMOVE JUMPER PLUG WHEN FIELD INSTALLING ELECTRIC HEAT
- ⚠ J2/P2, J144/P144 AND S63 ARE NOT USED ON -036,042,048,060,072, 088 AND 100 UNITS
- ⚠ S20 USED ON -2 B UNITS ONLY
- ⚠ TB2,S48 OR CB10 MAY BE USED
- ⚠ TB3 IS USED ON SOME UNITS
- ⚠ USED WITH TWO SPEED BLOWER ONLY

WIRING DIAGRAM		10/98
HEATING-ELECTRIC		
EHA-7, 7.5, 10, 15, 20, 22.5 25, 30-1, 2-Y		
HEATING SECTION-A5		
Supersedes Form No.	New Form No.	
532,804W	532,957W	
© 1998 Lennox Industries Inc.		Litho U.S.A.

EHA-45, 60KW - Y

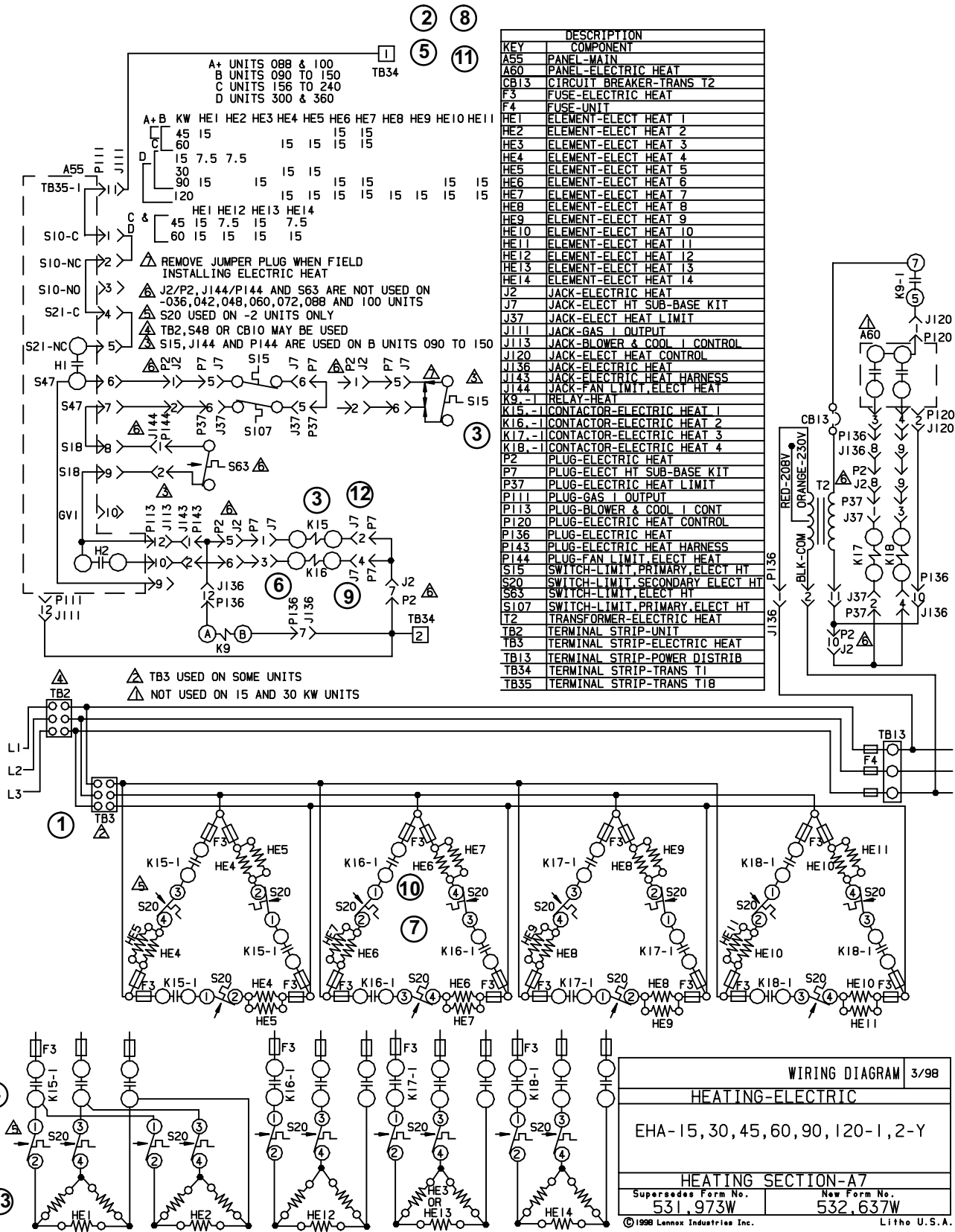

WIRING DIAGRAM 3/98	
HEATING-ELECTRIC	
EHA-15, 30, 45, 60, 90, 120-1, 2-Y	
HEATING SECTION-A7	
Supersedes Form No.	New Form No.
531,973W	532,637W
© 1998 Lennox Industries Inc. Litho U.S.A.	

Sequence of Operation -EHA 7.5, 15, 22.5, 30, 45, 60 kW - Y and G, J, M

NOTE: This sequence of operation is for all Electric Heat kW ratings Y through J voltages. Each step of operation is numbered and can be followed in sequence on the diagrams. Operation for G, J, and M voltages will be the same.

HEATING ELEMENTS:

- 1 - Terminal Strip TB3 is energized when the unit disconnect closes. TB3 supplies line voltage to electric heat elements HE1 through HE7. Each element is protected by fuse F3.

FIRST STAGE HEAT:

- 2 - Heating demand initiates at W1 in thermostat.
- 3 - 24VAC is routed through TB34 to the main control module A55. After A55 proves N.C. primary limit S15 and secondary limit S20, the electric heat contactor K15 is energized.
- 4 - N.O. contacts K15-1 closes allowing the first bank of elements to be energized.

SECOND STAGE HEAT:

- 5 - With the first stage heat operating, an additional heating demand initiates at W2 in the thermostat.
- 6 - 24VAC is routed through the main control module A55, which in turn energizes the electric heat contactor K16.
- 7 - N.O. contacts K16-1 close allowing the second set of elements to be energized.

END OF SECOND STAGE HEAT:

- 8 - Heating demand is satisfied. Terminal W2 in the thermostat is de-energized.
- 9 - Electric heat contactor K16 is de-energized.
- 10- The second set of electric heat elements are de-energized.

END OF FIRST STAGE HEAT:

- 11- Heating demand is satisfied. Terminal W1 in the thermostat is de-energized.
- 12- Electric heat contactor K15 is de-energized.
- 13- The first set of electric heat elements are de-energized.