

LGA / LCA / LHA SERIES

The LGA / LCA / LHA 13, 15, 17.5, 20 and 25 ton (46, 53, 62, 70 and 88 kW) units are configured to order units (CTO) with a wide selection of factory installed options. The LGA180/210/240/300S gas/electric packaged rooftop units are available in 260,000 Btuh or 470,000 Btuh (76.2 kW or 137.7 kW) heating inputs. The LGA156H is available in 260,000 Btuh only. LGA240H is the only model available in 360,000 BTUH (105.5 kW) Gas heat sections are designed with Lennox' aluminized steel tube heat exchangers. The LCA156H/180/210/240/300S cooling packaged rooftop units are equipped with the same cooling sections as the LGA156H/180/210/240/300S units. Optional electric heat is factory-or-field-installed in LCA units. Electric heat operates in single or multiple stages depending on the kW input size. 15kW through 60kW heat sections are available for the LCA156H and LCA180 and 15kW through 90kW heat sections are available for the LCA210/240/300S. LGA and LCA units have identical refrigerant circuits with 13, 15, 17.5, 20 or 25 ton (46, 53, 62, 70 or 88 kW) cooling capacities. LGA/LCA156H/180 units utilize three compressors, while the LGA/LCA210,240 and 300S units utilize four compressors.

The LGA/LCA240H4 is designed for R410A refrigerant. Operating pressures and pressure switch settings are higher than R22 charged units. Service equipment must be rated for R410A.

The LHA180 and 240 packaged heat pump units are available in 188,000 Btuh through 220,000 Btuh (55.1 kW through 64.5 kW) heating outputs and 15 or 20-ton (52.8 or 70.3 kW) cooling capacities. The LHA180/240 refrigerant systems utilize two compressors, two reversing valves, two accumulators, and other parts common to a heat pump. Optional auxiliary electric heat is factory-or-field-installed in LHA units. Electric heat operates in single or multiple stages depending on the kW input size. 15kW through 60kW heat sections are available for the LHA180 and 15kW through 90kW heat sections are available for the LHA240.

If the unit must be lifted for service, rig unit by attaching four cables to the holes located in the unit base rail (two holes at each corner). Refer to the installation instructions for the proper rigging technique.

Information contained in this manual is intended for use by qualified service technicians only. All specifications are subject to change. Procedures outlined in this manual are presented as a recommendation only and do not supersede or replace local or state codes.



LGA240 (20 TON) SHOWN

Table of Contents

Specifications	2
Optional Accessories	8
Electrical Data	16
Blower Data	20
Parts Arrangement	30
I Unit Components	35
II Placement and Installation	62
III Charging	62
IV Start Up - Operation	64
V System Service Checks	65
High Altitude	66
VI Maintenance	68
VII Accessories	68
VIII Wiring and Operation Sequence	77

⚠ WARNING



Shock Hazard
Improper service and failure to follow safety warnings exactly could result in dangerous operation, serious injury, death or property damage. Remove all power at disconnect before removing access panel.

SPECIFICATIONS - LCA/LGA 156/180

Model No.		LCA/LGA156H	LCA/LGA180S	LCA/LGA180H		
Efficiency Type		High (H)	Standard (S)	High (H)		
Cooling Ratings	Gross Cooling Capacity - Btuh (kW)	155,000 (45.4)	186,000 (54.5)	188,000 (55.1)		
	★Net Cooling Capacity - Btuh (kW)	150,000 (44.0)	180,000 (52.7)	182,000 (53.3)		
	Total Unit Power (kW)	13.0	19.6	15.8		
	★EER (Btuh/Watt)	11.5	9.2	11.5		
	★Integrated Part Load Value (Btuh/Watt)	12.6	10.0	12.5		
Refrigerant Charge Furnished (HCFC-22)		Circuit 1	11 lbs. 0 oz. (4.99 kg)	9 lbs. 0 oz. (4.08 kg)	11 lbs. 0 oz. (4.99 kg) Humiditrol Units 13 lbs. 8 oz. (6.12 kg)	
		Circuit 2	11 lbs.. 0 oz. (4.99 kg)	9 lbs. 0 oz. (4.08 kg)	11 lbs. 0 oz. (4.99 kg) Humiditrol Units 13 lbs. 8 oz. (6.12 kg)	
		Circuit 3	11 lbs. 0 oz. (4.99 kg)	9 lbs. 0 oz. (4.08 kg)	11 lbs. 0 oz. (4.99 kg) Humiditrol Units 11 lbs. 0 oz. (4.99 kg)	
Two Stage Heating Capacity (Natural or LPG/Propane Gas (at Sea Level))	Model No.	LGA156		LGA180		
	Heat Input Type	Low (L)	Standard (S)	Low (L)	Standard (S) High (H)	
	Input (low) — Btuh (kW)	169,000 (49.5)	169,000 (49.5)	169,000 (49.5)	169,000 (49.5)	305,000 (89.4)
	Output (low) — Btuh (kW)	135,000 (39.6)	135,000 (39.6)	135,000 (39.6)	135,000 (39.6)	244,000 (71.5)
	Input (High) — Btuh (kW)	----	260,000 (76.2)	----	260,000 (76.2)	470,000 (137.7)
	Output (High) — Btuh (kW)	----	208,000 (60.9)	----	208,000 (60.9)	376,000 (110.2)
	A.G.A./C.G.A. Thermal Efficiency	80.0%				
Gas Supply Connections npt — in. -Natural I or LPG/Propane		1				
Recommended Gas Supply Pressure - wc. in. (kPa)	Natural	7 (1.7)				
	LPG/Propane	11 (2.7)				
Blower wheel nominal dia. x width — in. (mm)		(2) 15 x 15 (381 x 381)				
Evaporator Blower and Drive Selection	2 hp (1.5 kW) Motor & Drive	Nominal motor output - hp (kW)	2 (1.5)	----		
		Max. usable motor output - hp (kW)	2.30 (1.7)	----		
		Voltage & phase	208/230v, 460v 575v-3ph	----		
		(Drive kit #) RPM range	(A) 535-725	----		
	3 hp (2.2 kW) Motor & Drives	Nominal motor output - hp (kW)	3 (2.2)			
		Max. usable motor output - hp (kW)	3.45 (2.6)			
		Voltage & phase	208/230v, 460v or 575v-3ph			
		(Drive kit #) RPM range	(A) 535-725 or (1 or 2) 685 — 865			
	5 hp (3.7 kW) Motor & Drives	Nominal motor horsepower (kW)	5 (3.7)			
		Max. usable motor output - hp (kW)	5.75 (4.3)			
		Voltage & phase	208/230v, 460v or 575v-3ph			
		(Drive kit #) RPM range	(2) 685 - 865, (3) 850 - 1045 or (4) 945 - 1185			
	7.5 hp (5.6 kW) Motor & Drive	Nominal motor output - hp (kW)	----	7.5 (5.6)		
		Max. usable motor output - hp (kW)	----	8.63 (6.4)		
		Voltage & phase	----	208/230v, 460v or 575v-3ph		
		(Drive kit #) RPM range	----	(5) 945 — 1185		
Evaporator Coil	Net face area — sq. ft. (m ²)	22.3 (2.07) total				
	Tube diameter — in. (mm) & No. of rows	3/8 (9.5) — 3				
	Fins per inch (m)	14 (551)				
	Drain connection no. & size — in. (mm) fpt	(1) 1 (25.4)				
	Expansion device type	Balanced Port Thermostatic Expansion Valve, removeable power head				
Condenser Coil	Net face area — sq. ft. (m ²)	56.5 (5.25) total				
	Tube diameter — in. (mm) & No. of rows	3/8 (9.5) — 1 (standard efficiency) / 3/8 (9.5) — 2 (high efficiency)				
	Fins per inch (m)	20 (787) standard & 16 (630) high				
Condenser Fans	Diameter — in. (mm) & No. of blades	(4) 24 (610) — 3				
	Total Air volume — cfm (L/s)	15,850 (7480) standard efficiency — 15,700 (7410) high efficiency				
	Motor horsepower (W)	(4) 1/3 (249)				
	Motor rpm	1075				
	Total Motor watts	1370 standard efficiency — 1380 high efficiency				
Filters (furnished)	Type of filter	Disposable, commercial grade, pleated				
	No. and size — in. (mm)	(6) 24 x 24 x 2 (610 x 610 x 51)				
Electrical characteristics		208/230v, 460v or 575v — 60 hertz — 3 phase				

☐ Using total air volume and system static pressure requirements determine from blower performance tables rpm and motor output required. Maximum usable output of motors furnished by Lennox are shown. In Canada, nominal motor output is also maximum usable motor output. If motors of comparable output are used, be sure to keep within the service factor limitations outlined on the motor nameplate.

★ Rated in accordance with ARI Standard 340/360 and certified to ARI; 95°F (35°C) outdoor air temperature and 80°F (27°C) db/67°F (19°C) wb entering evaporator air; minimum external duct static pressure. Integrated Part Load Value tested at 80°F (27°C) outdoor air temperature.

NOTE — ARI capacity is net and includes evaporator blower motor heat deduction. Gross capacity does not include evaporator blower motor heat deduction.

SPECIFICATIONS - LCA/LGA-210

Model No.		LCA/LGA210S	LCA/LGA210H	
Efficiency Type		Standard (S)	High (H)	
Cooling Ratings	Gross Cooling Capacity - Btuh (kW)	212,000 (62.1)	218,000 (63.9)	
	★Net Cooling Capacity - Btuh (kW)	204,000 (59.8)	210,000 (61.5)	
	Total Unit Power (kW)	22.7	18.8	
	★EER (Btuh/Watt)	9.0	11.2	
	★Integrated Part Load Value (Btuh/Watt)	9.5	11.5	
Refrigerant Charge Furnished (HCFC-22)	Circuit 1	7 lbs. 8 oz. (3.4 kg)	11 lbs. 0 oz. (4.99 kg) Humiditrol Unit 13 lbs. 0 oz. (5.90 kg)	
	Circuit 2	7 lbs. 8 oz. (3.4 kg)	11 lbs. 0 oz. (4.99 kg) Humiditrol Unit 13 lbs. 0 oz. (5.90 kg)	
	Circuit 3	7 lbs. 8 oz. (3.4 kg)	11 lbs. 0 oz. (4.99 kg) Humiditrol Units 11 lbs. 0 oz. (4.99 kg)	
	Circuit 4	7 lbs. 8 oz. (3.4 kg)	11 lbs. 0 oz. (4.99 kg) Humiditrol Units 11lbs. 0 oz. (4.99 kg)	
Two Stage Heating Capacity (Natural or LPG/Propane Gas (at Sea Level)	Model No.		LGA210	
	Heat Input Type		Standard (S)	
	Input (low) — Btuh (kW)		169,000 (49.5)	
	Output (low) — Btuh (kW)		135,000 (39.6)	
	Input (High) — Btuh (kW)		260,000 (76.2)	
	Output (High) — Btuh (kW)		208,000 (60.9)	
	A.G.A./C.G.A. Thermal Efficiency		80.0%	
Gas Supply Connections npt — in. -Natural I or LPG/Propane		1		
Recommended Gas Supply Pressure - wc. in. (kPa)	Natural	7 (1.7)		
	LPG/Propane	11 (2.7)		
Evaporator Blower and Drive Selection	Blower wheel nominal dia. x width — in. (mm)		(2) 15 x 15 (381 x 381)	
	3 hp (2.2 kW) Ⓜ Motor & Drives	Nominal motor output - hp (kW)	3 (2.2)	
		Max. usable motor output - hp (kW)	3.45 (2.6)	
		Voltage & phase	208/230v, 460v or 575v-3ph	
		(Drive kit #) RPM range	(A) 535-725 or (1 or 2) 685 — 865	
	5 hp (3.7 kW) Ⓜ Motor & Drives	Nominal motor horsepower (kW)	5 (3.7)	
		Max. usable motor output - hp (kW)	5.75 (4.3)	
		Voltage & phase	208/230v, 460v or 575v-3ph	
		(Drive kit #) RPM range	(2) 685 - 865, (3) 850 - 1045 or (4) 945 - 1185	
	7.5 hp (5.6 kW) Ⓜ Motor & Drive	Nominal motor output - hp (kW)	7.5 (5.6)	
		Max. usable motor output - hp (kW)	8.63 (6.4)	
		Voltage & phase	208/230v, 460v or 575v-3ph	
(Drive kit #) RPM range		(5) 945 — 1185		
Evaporator Coil	Net face area — sq. ft. (m ²)		22.3 (2.07) total	
	Tube diameter — in. (mm) & No. of rows		3/8 (9.5) — 3 (standard efficiency) / 3/8 (9.5) — 4 (high efficiency)	
	Fins per inch (m)		14 (551)	
	Drain connection no. & size — in. (mm) fpt		(1) 1 (25.4)	
	Expansion device type		Balanced Port Thermostatic Expansion Valve, removeable power head	
Condenser Coil	Net face area — sq. ft. (m ²)		56.5 (5.25) total	
	Tube diameter — in. (mm) & No. of rows		3/8 (9.5) — 1 (standard efficiency) / 3/8 (9.5) — 2 (high efficiency)	
	Fins per inch (m)		20 (787) standard & 16 (630) high	
Condenser Fans	Diameter — in. (mm) & No. of blades		(4) 24 (610) — 3	
	Total Air volume — cfm (L/s)		15,850 (7480) standard efficiency — 15,700 (7410) high efficiency	
	Motor horsepower (W)		(4) 1/3 (249)	
	Motor rpm		1075	
	Total Motor watts		1370 standard efficiency — 1380 high efficiency	
Filters (furnished)	Type of filter		Disposable, commercial grade, pleated	
	No. and size — in. (mm)		(6) 24 x 24 x 2 (610 x 610 x 51)	
Electrical characteristics		208/230v, 460v or 575v — 60 hertz — 3 phase		

Ⓜ Using total air volume and system static pressure requirements determine from blower performance tables rpm and motor output required. Maximum usable output of motors furnished by Lennox are shown. In Canada, nominal motor output is also maximum usable motor output. If motors of comparable output are used, be sure to keep within the service factor limitations outlined on the motor nameplate.

★Rated in accordance with ARI Standard 340/360 and certified to ARI; 95°F (35°C) outdoor air temperature and 80°F (27°C) db/67°F (19°C) wb entering evaporator air; minimum external duct static pressure. Integrated Part Load Value tested at 80°F (27°C) outdoor air temperature.

NOTE — ARI capacity is net and includes evaporator blower motor heat deduction. Gross capacity does not include evaporator blower motor heat deduction.

SPECIFICATIONS - LCA/LGA 240/300

Model No.		LCA/LGA240S	LCA/LGA300S		
Cooling Ratings	Efficiency Type	Standard (S)	Standard (S)		
	Gross Cooling Capacity — Btuh (kW)	248,000 (72.7)	301,600 (88.4)		
	★Net Cooling Capacity — Btuh (kW)	238,000 (69.7)	L1284,000 (83.3)		
	Total Unit Power (kW)	26.4	31.5		
	★EER (Btuh/Watt)	9.0	L19.0		
	★Integrated Part Load Value (Btuh/Watt)	10.0	L19.5		
Refrigerant Charge Furnished (R-22)	Circuit 1 Circuit 2 Circuit 3 Circuit 4	10 lbs. 0 oz. (4.54 kg) 10 lbs. 0 oz. (4.54 kg) 10 lbs. 0 oz. (4.54 kg) 10 lbs. 0 oz. (4.54 kg)	11 lbs. 4 oz. (5.10 kg) 11 lbs. 4 oz. (5.10 kg) 11 lbs. 4 oz. (5.10 kg) 11 lbs. 4 oz. (5.10 kg)		
Refrigerant Charge Furnished (R-410A)	Circuit 1 Circuit 2 Circuit 3 Circuit 4	N/A			
Refrigerant Charge Furnished (R-22) with Humiditrol option	Circuit 1 Circuit 2 Circuit 3 Circuit 4	N/A			
Two Stage Heating Capacity Natural or Propane Gas at sea level)	Model No.	LGA240	LGA300		
	Heat Input Type	Standard (S)	Standard (S)	High (H)	
	Input (low) — Btuh (kW)	169,000 (49.5)	169,000 (49.5)	305,000 (89.4)	
	Output (low) — Btuh (kW)	135,000 (39.6)	135,000 (39.6)	244,000 (71.5)	
	Input (High) — Btuh (kW)	260,000 (76.2)	260,000 (76.2)	470,000 (137.7)	
	Output (High) — Btuh (kW)	208,000 (60.9)	208,000 (60.9)	376,000 (110.2)	
A.G.A./C.G.A. Thermal Efficiency		80.0%			
Gas Supply Connections npt — in.	Natural	1			
	LPG/Propane	1			
Recommended Gas Supply Pressure — wc. in. (kPa)	Natural	7 (1.7)			
	LPG/Propane	11 (2.7)			
Evaporator Blower and Drive Selection	Blower wheel nominal dia. x width — in. (mm)		(2) 15 x 15 (381 x 381)		
	3 hp (2.2 kW) L1Motor & Drives	Nominal motor output — hp (kW)	3 (2.2)	----	
		Max. usable motor output — hp (kW)	3.45 (2.6)	----	
		Voltage & phase	208/230v, 460v or 575v-3ph	----	
		(Drive kit #) RPM range	(1 or 2) 685 — 865	----	
	5 hp (3.7 kW) L1Motor & Drives	Nominal motor output — hp (kW)	5 (3.7)		
		Max. usable motor output — hp (kW)	5.75 (4.3)		
		Voltage & phase	208/230v, 460v or 575v-3ph		
		(Drive kit #) RPM range	(2) 685 - 865, (3) 850 - 1045 or (4) 945 - 1185		
	7.5 hp (5.6 kW) L1Motor & Drive	Nominal motor horsepower (kW)	7.5 (5.6)		
		Max. usable motor output — hp (kW)	8.63 (6.4)		
		Voltage & phase	208/230v, 460v or 575v-3ph		
(Drive kit #) RPM range		(5) 945 — 1185			
10 hp (7.5 kW) L1Motor & Drive	Nominal motor horsepower (kW)	10 hp (7.5)			
	Max. usable motor output — hp (kW)	11.5 (8.6)			
	Voltage & phase	208/230v, 460v or 575v-3ph			
	(Drive kit #) RPM range	(6) 1045-1285 rpm (8) 1135-1365)			
Evaporator Coil	Net face area — sq. ft. (m ²)		22.3 (2.07) total		
	Tube diameter — in. (mm) & No. of rows		3/8 (9.5) — 3 (Standard Efficiency) 3/8 (9.5) — 4 (High Efficiency)	3/8 (9.5) — 4	
	Fins per inch (m)		14 (551)		
	Drain connection no. & size — in. (mm) fpt		(1) 1 (25.4)		
	Expansion device type		Balanced Port Thermostatic Expansion Valve, removeable power head		
Condenser Coil	Net face area — sq. ft. (m ²)		56.5 (5.25) total		
	Tube diameter — in. (mm) & No. of rows		3/8 (9.5) — 2		
	Fins per inch (m)		20 (787)		
Condenser Fans	Diameter — in. (mm) & No. of blades		(4) 24 (610) — 3		
	Total Air volume — cfm (L/s)		15,450 (7290)	16,000 (7550)	
	Motor horsepower (W)		(4) 1/3 (249)	(4) 1/2 (373)	
	Motor rpm		1075		
	Total Motor watts		1395	1800	
Filters (furnished)	Type of filter		Disposable, commercial grade, pleated		
	No. and size — in. (mm)		(6) 24 x 24 x 2 (610 x 610 x 51)		
Electrical characteristics		208/230v, 460v or 575v — 60 hertz — 3 phase			

L1Using total air volume and system static pressure requirements determine from blower performance tables rpm and motor output required. Maximum usable output of motors furnished by Lennox are shown. In Canada, nominal motor output is also maximum usable motor output. If motors of comparable output are used, be sure to keep within the service factor limitations outlined on the motor nameplate. ★Rated in accordance with ARI Standard 340/360 and certified to ARI: 95°F (35°C) outdoor air temperature and 80°F (27°C) db/67°F (19°C) wb entering evaporator air; minimum external duct static pressure. Integrated Part Load Value tested at 80°F (27°C) outdoor air temperature. L1Tested at conditions included in ARI Standard 340/360. NOTE — ARI capacity is net and includes evaporator blower motor heat deduction. Gross capacity does not include evaporator blower motor heat deduction.

SPECIFICATIONS - LCA/LGA 240H

General Data		Nominal Tonnage (kW)	20 Ton LCA/LGA240H2B R-22 - LCA/LGA240H4B R-410A - *LCA-5 & LGA-6 R410A High		
Cooling Performance		Efficiency Type	High		
Cooling Performance	Gross Cooling Capacity - Btuh (kW)		252,000 (73.8) - 254,000 (74.4), * 240,000 (70.32)		
	¹ Net Cooling Capacity - Btuh (kW)		242,000 (70.9) - 244,000 (71.5), * 230,000 (67.40)		
	ARI Rated Air Flow - cfm (L/s)		7500 (3540)		
	Total Unit Power (kW)		22.0 - 23.2, * 20.9		
	¹ EER (Btuh/Watt)		11.0 - 10.5, *11.0		
Cooling Performance	² Integrated Part Load Value (Btuh/Watt)		11.8 - 11.5, *12.0		
	Refrigerant Charge Furnished R-22 -R410A	Circuit 1	11 lbs. 4 oz. (5.10 kg) - 12 lbs 0 oz (5.44 kg), *10 lbs. 8 oz.		
		Circuit 2	11 lbs. 4 oz. (5.10 kg) - 12 lbs 0 oz (5.44 kg), *10 lbs. 8 oz.		
		Circuit 3	11 lbs. 4 oz. (5.10 kg) - 12 lbs 0 oz (5.44 kg), *10 lbs. 8 oz.		
Circuit 4		11 lbs. 4 oz. (5.10 kg) - 12 lbs 0 oz (5.44 kg), *10 lbs. 8 oz.			
Cooling Performance	Refrigerant Charge Furnished R-22 -R410A with Humiditrol Option	Circuit 1	12 lbs. 4 oz. (5.56 kg) - 13 lbs 0 oz (5.90 kg), * 11 lbs. 8 oz.		
		Circuit 2	12 lbs. 4 oz. (5.56 kg) - 13 lbs 0 oz (5.90 kg), *11 lbs. 8 oz.		
		Circuit 3	11 lbs. 4 oz. (5.10 kg) - 12 lbs 0 oz (5.44 kg), * 10 lbs. 8 oz.		
		Circuit 4	11 lbs. 4 oz. (5.10 kg) - 12 lbs 0 oz (5.44 kg), 10 lbs. 8 oz.		
Gas Heating Performance	Heat Input Type		Standard 2 Stage	Medium 2 Stage	High 2 Stage
	Input - Btuh (kW)	First Stage	169,000 (49.5)	234,000 (68.6)	312,000 (91.4)
		Second Stage	260,000 (76.2)	360,000 (105.5)	480,000 (140.6)
	Output - Btuh (kW)	Second Stage	208,000 (60.9)	288,000 (84.4)	384,000 (112.5)
		CSA Thermal Efficiency		80.0%	
	Gas Supply Connections		1 in.		
Recommended Gas Supply Pressure		Natural 7 in. w.g. (1.7 kPa) LPG/Propane 11 in. w.g. (2.7 kPa)			
Compressor Type (no.)		Scroll (4)			
Condenser Coils	Net face area - sq. ft. (m ²) total		56.5 (5.25)		
	Tube diameter - in. (mm)		3/8 (9.5)		
	Number of rows		2		
	Fins per inch (m)		20 (787)		
Condenser Fans	Motor horsepower (W)		(4) 1/3 (249)		
	Motor rpm		1075		
	Total Motor watts		1395		
	Diameter - in. (mm)		(4) 24 (610)		
	Number of blades		3		
	Total Air volume - cfm (L/s)		15,450 (7290)		
Evaporator Coils	Net face area - sq. ft. (m ²) total		22.3 (2.07)		
	Tube diameter - in. (mm)		3/8 (9.5)		
	Number of rows		4		
	Fins per inch (m)		14 (551)		
	Condensate Drain - number and size		(1) 1 in. NPT coupling		
	Expansion device type		Balanced Port Thermostatic Expansion Valve, removeable power head		
³ Indoor Blower and Drive Selection	Nominal motor output		5 hp (3.7 kW) - 7.5 hp (5.6 kW) - 10 hp (7.5 kW)		
	Max. usable motor output (US Only)		5.75 hp (4.3 kW) - 8.63 hp (6.4 kW) - 11.5 hp (8.6 kW)		
	Motor - Drive kit		5 hp kit #2 - 685 - 865 rpm kit #3 - 850 - 1045 rpm kit #4 945 - 1185 rpm 7.5 hp kit #5 - 945 - 1185 rpm kit #6 - 1045 - 1285 rpm kit #7 - 850 - 1045 rpm 10 hp kit #6 - 1045-1285 rpm kit #8 - 1135-1365 rpm		
Blower wheel nominal dia. x width		(2) 15 x 15 in. (381 x 381 mm)			
Filters	Type of filter		Disposable		
	Number and size - in. (mm)		(6) 24 x 24 x 2 (610x610x51)		
Electrical characteristics		208/230V, 460V or 575V - 60 hertz - 3 phase			

NOTE - Net capacity includes evaporator blower motor heat deduction. Gross capacity does not include evaporator blower motor heat deduction.
¹ Certified in accordance with the ULE certification program, which is based on ARI Standard 340/360; 95°F (35°C) outdoor air temperature and 80°F (27°C) db/67°F (19°C) wb entering evaporator air; minimum external duct static pressure.
² Integrated Part Load Value tested at 80°F (27°C) outdoor air temperature.
³ Using total air volume and system static pressure requirements determine from blower performance tables rpm and motor output required. Maximum usable output of motors furnished by Lennox are shown. In Canada, nominal motor output is also maximum usable motor output. If motors of comparable output are used, be sure to keep within the service factor limitations outlined on the motor nameplate.

**SPECIFICATIONS - LHA 180/240
Units with Reciprocating Compressors**

Model No.		LHA180H	LHA240H	
Cooling Ratings	Efficiency Type	High (H)	High (H)	
	Gross Cooling Capacity — Btuh (kW)	185,000 (54.2)	233,000 (68.3)	
	★Net Cooling Capacity — Btuh (kW)	180,000 (52.7)	226,000 (66.2)	
	Total Unit Power (kW)	18.0	21.5	
	★EER (Btuh/Watt)	10.0	10.5	
	★Integrated Part Load Value (Btuh/Watt)	11.2	11.5	
High Temperature Heating Ratings	*Total Heating Capacity — Btuh (kW)	188,000 (55.1)	220,000 (64.5)	
	*Total Unit Power (kW)	16.7	20.2	
	*C.O.P.	3.3	3.2	
Low Temperature Heating Ratings	*Total Heating Capacity — Btuh (kW)	108,000 (31.6)	118,000 (34.6)	
	*Total Unit Power (kW)	13.2	15.0	
	*C.O.P.	2.4	2.3	
Refrigerant Charge Furnished (HCFC-22)	Circuit 1	24 lbs. 8 oz. (11.11 kg)	26 lbs. 0 oz. (11.79 kg)	
	Circuit 2	24 lbs. 8 oz. (11.11 kg)	26 lbs. 0 oz. (11.79 kg)	
Indoor Coil Blower and Drive Selection	Blower wheel nominal dia. x width — in. (mm)		(2) 15 x 15 (381 x 381)	
	3 hp (2.2 kW) ☐ Motor & Drives	Nominal motor output — hp (kW)	3 (2.2)	
		Max. usable motor output — hp (kW)	3.45 (2.6)	
		Voltage & phase	208/230v, 460v or 575v-3ph	
		(Drive kit #) RPM range	(1 or 2) 685 — 865	
	5 hp (3.7 kW) ☐ Motor & Drives	Nominal motor horsepower (kW)	5 (3.7)	
		Max. usable motor output — hp (kW)	5.75 (4.3)	
		Voltage & phase	208/230v, 460v or 575v-3ph	
		(Drive kit #) RPM range	(2) 685 - 865, (3) 850 - 1045 or (4) 945 - 1185	
	7.5 hp (5.6 kW) ☐ Motor & Drive	Nominal motor horsepower (kW)	7.5 (5.6)	
		Max. usable motor output — hp (kW)	8.63 (6.4)	
		Voltage & phase	208/230v, 460v or 575v-3ph	
		(Drive kit #) RPM range	(5) 945 — 1185	
	10 hp (7.5 kW) ☐ Motor & Drive LHA240H ONLY	Nominal motor horsepower (kW)	10 hp (7.5)	
Max. usable motor output — hp (kW)		11.5 (8.6)		
Voltage & phase		208/230v, 460v or 575v-3ph		
(Drive kit #) RPM range		(6) 1045-1285 rpm (8) 1135-1365 rpm		
Indoor Coil	Net face area — sq. ft. (m ²)		22.3 (2.07)	
	Tube diameter — in. (mm) & No. of rows		3/8 (9.5) — 3 3/8 (9.5) — 4	
	Fins per inch (m)		14 (551)	
	Drain connection no. & size — in. (mm) fpt		(1) 1 (25.4)	
	Expansion device type		Balanced Port Thermostatic Expansion Valve, removeable power head	
Outdoor Coil	Net face area — sq. ft. (m ²)		57.0 (5.30)	
	Tube diameter — in. (mm) & No. of rows		3/8 (9.5) — 2	
	Fins per inch (m)		20 (787)	
	Expansion device type		Balanced Port Thermostatic Expansion Valve, removeable power head	
Outdoor Fans	Diameter — in. (mm) & No. of blades		(4) 24 (610) — 3	
	Total Air volume — cfm (L/s)		15,450 (7290)	
	Motor horsepower (W)		(4) 1/3 (249)	
	Motor rpm		1075	
	Total Motor watts		1395	
Filters (furnished)	Type of filter		Disposable, commercial grade, pleated	
	No. and size — in. (mm)		(6) 24 x 24 x 2 (610 x 610 x 51)	
Electrical characteristics		208/230v, 460v or 575v — 60 hertz — 3 phase		

★Rated in accordance with ARI Standard 340/360 and certified to ARI. Integrated Part Load Value tested at 80°F (27°C) outdoor air temperature.

Cooling Ratings— 95°F (35°C) outdoor air temperature and 80°F (27°C) db/67°F (19°C) wb entering indoor coil air.

High Temperature Heating Ratings— 47°F (8°C) db/43°F (6°C) wb outdoor air temperature and 70°F (21°C) entering indoor coil air.

Low Temperature Heating Ratings— 17°F (-8°C) db/15°F (-9°C) wb outdoor air temperature and 70°F (21°C) entering indoor coil air.

NOTE — ARI capacity is net and includes indoor blower motor heat deduction. Gross capacity does not include indoor blower motor heat deduction.

☐ Using total air volume and system static pressure requirements determine from blower performance tables rpm and motor output required. Maximum usable output of motors furnished by Lennox are shown. In Canada, nominal motor output is also maximum usable motor output. If motors of comparable output are used, be sure to keep within the service factor limitations outlined on the motor nameplate.

**SPECIFICATIONS - LHA 180/240
Units with Scroll Compressors**

		LHA180H	LHA240H	
Cooling Performance	Model No.	LHA180H	LHA240H	
	Nominal Tonnage	15	20	
	Efficiency Type	High (H)	High (H)	
	Type and Number of compressors	Scroll (2)	Scroll (2)	
	Gross Cooling Capacity - Btuh (kW)	187,000 (54.8)	227,000 (66.5)	
	① Net Cooling Capacity - Btuh (kW)	182,000 (52.3)	220,000 (64.5)	
	Total Unit Power (kW)	16.5	21.6	
	① EER (Btuh/Watt)	11.0	10.2	
	② Integrated Part Load Value (Btuh/Watt)	12.0	11.0	
	Refrigerant Charge	Circuit 1 24 lbs. 8 oz. (11.1 kg)	Circuit 2 24 lbs. 8 oz. (11.1 kg)	26 lbs. 0 oz. (11.8 kg) 26 lbs. 0 oz. (11.8 kg)
Heating Performance	① Total High Heating Capacity - Btuh (kW)	192,000 (56.2)	220,000 (64.5)	
	Total Unit Power (kW)	17.1	19.5	
	① C.O.P.	3.3	3.3	
	① Total Low Heating Capacity - Btuh (kW)	106,000 (31.0)	118,000 (34.6)	
	Total Unit Power (kW)	15.5	16.5	
	① C.O.P.	2.0	2.1	
Outdoor Coil	Net face area - sq. ft. (m ²)	57.0 (5.30)	57.0 (5.30)	
	Tube diameter - in. (mm)	3/8 (9.5)	3/8 (9.5)	
	Number of rows	2	2	
	Fins per inch (m)	20 (787)	20 (787)	
	Expansion device type	Balanced Port Thermostatic Expansion Valve, removeable power head		
Outdoor Fans	Motor horsepower (W)	(4) 1/3 (249)	(4) 1/3 (249)	
	Motor rpm	1075	1075	
	Total Motor watts	1395	1395	
	Diameter - in. (mm)	(4) 24 (610)	(4) 24 (610)	
	Number of blades	3	3	
	Total Air volume - cfm (L/s)	15,450 (7290)	15,450 (7290)	
Indoor Coil	Net face area - sq. ft. (m ²)	22.3 (2.07)	22.3 (2.07)	
	Tube diameter - in. (mm)	3/8 (9.5)	3/8 (9.5)	
	Number of rows	3	4	
	Fins per inch (m)	14 (551)	14 (551)	
	Condensate Drain - number and size	(1) 1 in. NPT coupling	(1) 1 in. NPT coupling	
	Expansion device type	Balanced Port Thermostatic Expansion Valve, removeable power head		
Indoor Blower and Drive Selection	④ Nominal motor output	3 hp (1.5 kW) 5 hp (3.7 kW) 7.5 hp (5.6 kW)	5 hp (3.7 kW) 7.5 hp (5.6 kW) 10 hp (7.5 kW)	
	Maximum usable motor output (US Only)	3.45 hp (2.6 kW) 5.75 (4.3 kW) 8.63 hp (6.4 kW)	5.75 (4.3 kW) 8.63 hp (6.4 kW) 11.5 hp (8.6 kW)	
	Motor - Drive kit	3 hp kit #A - 535 - 725 rpm kit #1 - 685 - 865 rpm kit #2 - 685 - 865 rpm	5 hp kit #2 - 685 - 865 rpm kit #3 - 850 - 1045 rpm kit #4 - 945 - 1185 rpm	
		5 hp kit #2 - 685 - 865 rpm kit #3 - 850 - 1045 rpm kit #4 - 945 - 1185 rpm	7.5 hp kit #5 - 945 - 1185 rpm kit #6 - 1045 - 1285 rpm kit #7 - 850 - 1045 rpm	
		7.5 hp kit# 5 - 945 - 1185 rpm kit# 6 - 1045 - 1285 rpm kit# 7 - 850 - 1045 rpm	10 hp kit #6 - 1045 - 1285 rpm kit #8 - 1135 - 1365 rpm	
	Wheel nominal diameter x width	(2) 15 x 15 in. (381 x 381 mm)	(2) 15 x 15 in. (381 x 381 mm)	
	Filters	Type of filter	Disposable	
		Number and size - in. (mm)	(6) 24 x 24 x 2 (610 x 610 x 51)	(6) 24 x 24 x 2 (610 x 610 x 51)
	Electrical characteristics		208/230V, 460V or 575V — 60 hertz — 3 phase	

① Certified in accordance with the ULE certification program, which is based on ARI Standard 340/360.
Cooling Ratings— 95°F (35°C) outdoor air temperature and 80°F (27°C) db/67°F (19°C) wb entering indoor coil air.
High Temperature Heating Ratings— 47°F (8°C) db/43°F (6°C) wb outdoor air temperature and 70°F (21°C) entering indoor coil air.
Low Temperature Heating Ratings— 17°F (-8°C) db/15°F (-9°C) wb outdoor air temperature and 70°F (21°C) entering indoor coil air.
NOTE — Net capacity includes evaporator blower motor heat deduction. Gross capacity does not include evaporator blower motor heat deduction.
② Integrated Part Load Value rated at 80°F (27°C) outdoor air temperature.
④ Using total air volume and system static pressure requirements determine from blower performance tables rpm and motor output required. Maximum usable output of motors furnished by Lennox are shown. In Canada, nominal motor output is also maximum usable motor output. If motors of comparable output are used, be sure to keep within the service factor limitations outlined on the motor nameplate.

OPTIONS / ACCESSORIES - LGA/LCA

Item		156	180	210	240	300S
COOLING SYSTEM						
Condensate Drain Trap	PVC - LTACDKP09/36	⊗	⊗	⊗	⊗	⊗
	Copper - LTACDKC09/36	⊗	⊗	⊗	⊗	⊗
Corrosion Protection		○	○	○	○	○
Efficiency	Standard		○	○	○	○
	High	○	○	○	○	
Refrigerant Type	R-22	○	○	○	○	○
	R-410A	○	○	○	○	
Service Valves (not for Humiditrol Units)		○	○	○	○	○
Stainless Steel Condensate Drain Pan		○	○	○	○	○
HEATING SYSTEM						
Combustion Air Intake Extensions	LTACAIK10/15	1x	1x	1x	1x	1x
Gas Heat Input	Low - 169 kBtuh input	○	○	○		
	Standard - 260 kBtuh input	○	○	○	○	○
	Medium - 360 kBtuh input	○	○	○	○	○
	High - 480 kBtuh input		○	○	○	○
Low Temperature Vestibule Heater		○	○	○	○	○
LPG/Propane Conversion Kits	169 kBtuh input (order 1 kit) - LTALPGK-130	x	x	x		
	260 kBtuh input (order 2 kits) - LTALPGK-130	1x	1x	1x	1x	1x
	360 kBtuh input (order 2 kits) - LTALPGK-180	1x	1x	1x	1x	1x
	480 kBtuh input (order 2 kits) - LTALPGK-240		1x	1x	1x	1x
Side Gas Piping Kit	C1GPKT01C-	x	x	x	x	x
Stainless Steel Heat Exchanger		○	○	○	○	○
Vertical Vent Extension	LTAWEK10/15	1x	1x	1x	1x	1x
Blower – SUPPLY AIR						
Constant Air Volume	2 hp Standard or High Efficiency	○				
	3 hp Standard or High Efficiency	○	○	○		
	5 hp Standard or High Efficiency	○	○	○	○	○
	7.5 hp Standard or High Efficiency		○	○	○	○
	10 hp Standard or High Efficiency				○	○
CABINET						
Coil Guards	88K52	x	x	x	x	x
Grille Guards	72K78	x	x	x	x	x
Hail Guards	88K25	x	x	x	x	x
Horizontal Return Air Panel Kit	C1HRAP10C-1	x	x	x	x	x
CONTROLS						
Blower Proving Switch	LTABPSK	⊗	⊗	⊗	⊗	⊗
Commercial Controls	L Connection® Building Automation System	⊗	⊗	⊗	⊗	⊗
	Novar® ETM-2051 Unit Controller	⊗	⊗	⊗	⊗	⊗
	Sectra™ Zoning System with Bypass Control - C0CTRL04BD1L	⊗	⊗	⊗	⊗	⊗
	Sectra™ Zoning System Single Zone Control - C0CTRL03BD1L	⊗	⊗	⊗	⊗	⊗
Dirty Filter Switch	LTADFSK	⊗	⊗	⊗	⊗	⊗
Fresh Air Tempering	45L78	⊗	⊗	⊗	⊗	⊗
Smoke Detector - Supply	LTSASDK10/36	⊗	⊗	⊗	⊗	⊗
Smoke Detector - Return	LTARSDK10/30	⊗	⊗	⊗	⊗	⊗
Supply Static Limit Switch	C0SNSR11AE1	x	x	x	x	x
	Mounting Kit - C0SNSR12AE1	x	x	x	x	x
HUMIDITROL CONDENSER REHEAT OPTION						
Humiditrol		H	H	H	H	S
Humidity Sensor Kit, Remote Mounted (required)	17M50	x	x	x	x	x
Remote Sensor Wall Seal Plate	58L33	x	x	x	x	x

NOTE - The catalog and model numbers that appear here are for ordering field installed accessories only.

⊗ - Field Installed or Configure to Order (factory installed)

○ - Configure to Order (Factory Installed)

x - Field Installed.

¹ - Order two each

S - Configure to Order (Factory Installed) Standard Efficiency Models Only

H - Configure to Order (Factory Installed) High Efficiency Models Only

OPTIONS / ACCESSORIES - LGA/LCA

Item	156	180	210	240	300S	
INDOOR AIR QUALITY						
Healthy Climate® UVC Germicidal Lamps	C1UVCL10C	x	x	x	x	x
MERV 11 High Efficiency Air Filters	24 x 24 x 2 order 6 per unit - C1FLTR10C	⊗	⊗	⊗	⊗	⊗
Replaceable Media Filter With Metal Mesh Frame (includes non-pleated filter media)	24 x 24 x 2 order 6 per unit - C1FLTR30C	x	x	x	x	x
CO ₂ Sensor - white case w/ display	LTAIAQSWDK03/36	x	x	x	x	x
CO ₂ Sensor - white case, no display	LTAIAQSWN03/36	x	x	x	x	x
CO ₂ Sensor - black case w/ display	LTAIAQSND03/36	x	x	x	x	x
CO ₂ Sensor - black case, no display	LTAIAQSDMBN03/36	x	x	x	x	x
CO ₂ Sensor Duct Mounting Kit	LTIAQSDMK03/36	x	x	x	x	x
Aspiration Box for duct mounting Sensor	LTIAQABD03/36	x	x	x	x	x
Handheld CO ₂ Monitor	LTAIAQSHM03/36	x	x	x	x	x
ELECTRICAL						
Voltage	208/230V - 3 phase	○	○	○	○	○
60 hz	460V - 3 phase	○	○	○	○	○
	575V - 3 phase	○	○	○	○	○
HACR Circuit Breakers						
Disconnect Switch	80 Amp - 84M13	⊗	⊗	⊗	⊗	⊗
	150 Amp - 84M14	⊗	⊗	⊗	⊗	⊗
	250 Amp - 84M15	⊗	⊗	⊗	⊗	⊗
GFI Service Outlets	LTAGFIK10/15	⊗	⊗	⊗	⊗	⊗
Phase Monitor		○	○	○	○	○
ECONOMIZER						
Economizer - Order Hood Separately	LAREMD18/24	⊗	⊗	⊗	⊗	⊗
Outdoor Air Hood (down-flow) Number of Filters - 16 x 25 x 1 in. - (406 x 635 x 25 mm)	C1HOOD10C (3)	⊗	⊗	⊗	⊗	⊗
Economizer Controls						
Differential Enthalpy	C1SNSR07AE	⊗	⊗	⊗	⊗	⊗
Single Enthalpy	C1SNSR06AE	⊗	⊗	⊗	⊗	⊗
Global, Enthalpy	Sensor Field Provided	○	○	○	○	○
Differential Sensible	Factory Setting	○	○	○	○	○
Barometric Relief						
Down-Flow Barometric Relief Dampers - Order Hood Separately	LAGED18/24	⊗	⊗	⊗	⊗	⊗
Hood for Down-Flow LAGED	C1HOOD20C	⊗	⊗	⊗	⊗	⊗
Horizontal Barometric Relief Dampers - Hood Furnished	LAGEDH18/24	⊗	⊗	⊗	⊗	⊗
OUTDOOR AIR						
Outdoor Air Dampers						
Damper Section (down-flow) - Motorized - Order Hood Separately	LAOADM18/24	⊗	⊗	⊗	⊗	⊗
Damper Section (down-flow) - Manual - Order Hood Separately	LAOAD18/24	⊗	⊗	⊗	⊗	⊗
Outdoor Air Hood (down-flow) Number of Filters - 16 x 25 x 1 in. - (406 x 635 x 25 mm)	C1HOOD10C (3)	⊗	⊗	⊗	⊗	⊗
Power Exhaust Fans						
Standard Static	208/230V - C1PWRE20C-1Y	⊗	⊗	⊗	⊗	⊗
	460V - C1PWRE20C-1G	⊗	⊗	⊗	⊗	⊗
	575V - C1PWRE20C-1J	⊗	⊗	⊗	⊗	⊗

NOTE - The catalog and model numbers that appear here are for ordering field installed accessories only.

⊗ - Field Installed or Configure to Order (factory installed)

○ - Configure to Order (Factory Installed)

x - Field Installed.

OPTIONS / ACCESSORIES - LGA/LCA

Item		156	180	210	240	300S
ROOF CURBS – CLIPLOCK 1000						
Down-Flow						
14 in. (356 mm) height	LARMF18/30S-14	x	x	x	x	x
18 in. (457 mm) height	LARMF18/30S-18	x	x	x	x	x
24 in. (610 mm) height	LARMF18/30S-24	x	x	x	x	x
Horizontal						
26 in. (660 mm) height	LARMFH18/24S-26	x	x	x	x	x
37 in. (940 mm) height	LARMFH18/24S-37	x	x	x	x	x
ROOF CURBS – STANDARD						
Down-Flow						
14 in. (356 mm) height	LARMF18/36-14	x	x	x	x	x
24 in. (610 m) height	LARMF18/36-24	x	x	x	x	x
Horizontal						
26 in. (660 mm) height - Rooftop applications	LARMFH18/24-26	x	x	x	x	x
37 in. (940 mm) height - Slab applications	LARMFH18/24-37	x	x	x	x	x
30 in. (762 mm) height - Rooftop applications	LARMFH30/36-30					x
41 in. (1041 mm) height - Slab applications	LARMFH30/36-41					x
Insulation Kits						
for LARMFH18/24-26	C1INSU11C	x	x	x	x	x
for LARMFH18/24-37	C1INSU13C	x	x	x	x	x
CEILING DIFFUSERS						
Step-Down - Order one	RTD11-185S or RTD11-185	x	x			
	RTD11-275S or RTD11-275			x	x	x
Flush - Order one	FD11-185S or FD11-185	x	x			
	FD11-275S or FD11-275			x	x	x
Transitions (Supply and Return) - Order one	LASRT18S or LASRT18	x	x			
	LASRT21/24S or LASRT21/24			x	x	x

NOTE - The catalog and model numbers that appear here are for ordering field installed accessories only.

X - Field Installed.

OPTIONS / ACCESSORIES - LHA

Item	Catalog No.	090	102	120	150	180	240
COOLING / HEATING SYSTEM							
Condensate Drain Trap	Copper - LTACDKC09/36	76M19	⊗	⊗	⊗	⊗	⊗
	PVC - LTACDKP09/36	76M18	⊗	⊗	⊗	⊗	⊗
Corrosion Protection	Factory	○	○	○	○	○	○
Efficiency	Standard	Factory	○	○	○	○	○
	High	Factory	○	○	○	○	○
Refrigerant Type	R-22	Factory	○	○	○	○	○
	R-410A	Factory	○	○	○	○	○
Stainless Steel Condensate Drain Pan	Factory	○	○	○	○	○	○
Blower – SUPPLY AIR							
Constant Air Volume	2 hp Standard or High Efficiency	Factory	○	○	○	○	
	3 hp Standard or High Efficiency	Factory	○	○	○	○	
	5 hp Standard or High Efficiency	Factory	○	○	○	○	
	7.5 hp Standard or High Efficiency	Factory					○ ○
	10 hp Standard or High Efficiency	Factory					○
CABINET							
Coil Guards	88K54	x	x	x	x		
	88K52					x	x
Hail Guards	88K27	x	x	x	x		
	88K25					x	x
CONTROLS							
Blower Proving Switch	C0SWCH01AE1-	30K49	⊗	⊗	⊗	⊗	⊗
Commercial Controls	L Connection® Building Automation System	- - -	⊗	⊗	⊗	⊗	⊗
	Novar® ETM-2051 Unit Controller	69K67	⊗	⊗	⊗	⊗	⊗
	Sectra™ Zoning System with Bypass Control - C0CTRL04EA1L	34M41	⊗	⊗	⊗	⊗	⊗
	Sectra™ Zoning System Single Zone Control - C0CTRL03EA1L	23M51	⊗	⊗	⊗	⊗	⊗
Dirty Filter Switch	C0SWCH00AE1-	30K48	⊗	⊗	⊗	⊗	⊗
Smoke Detector - Supply	LTSASDK10/36	70K87	⊗	⊗	⊗	⊗	⊗
Smoke Detector - Return	LTARSDK10/30	70K86	⊗	⊗	⊗	⊗	⊗
Supply Static Limit Switch	C0SNSR11AE1	79M80				x	x
	Mounting Kit - C0SNSR12AE1	79M81				x	x
ELECTRICAL							
Voltage 60 hz	208/230V - 3 phase	Factory	○	○	○	○	○
	460V - 3 phase	Factory	○	○	○	○	○
	575V - 3 phase	Factory	○	○	○	○	○
HACR Circuit Breakers	Factory	○	○	○	○	○	○
GFI Service Outlets	LTAGFIK10/15	74M70	⊗	⊗	⊗	⊗	
Phase Monitor	Factory	○	○	○	○	○	○
Disconnect Switch - See Electrical / Electric Heat Tables	80 Amp	84M13				⊗	⊗
	150 Amp	84M14	⊗	⊗	⊗	⊗	⊗
	250 Amp	84M15				⊗	⊗
GFI Service Outlets	LTAGFIK10/15	74M70				⊗	⊗

NOTE - The catalog and model numbers that appear here are for ordering field installed accessories only.

⊗ - Field Installed or Configure to Order (factory installed).

○ - Configure to Order (Factory Installed).

X - Field Installed.

OPTIONS / ACCESSORIES - LHA

Item	Catalog No.	090	102	120	150	180	240
INDOOR AIR QUALITY							
Air Filters							
Healthy Climate® High Efficiency Air Filters 18 x 24 x 2 - order 4 per unit	MERV 11 - C1FLTR20B-1	97L86	⊗	⊗	⊗	⊗	
	MERV 15 - C1FLTR50B-1	28W04	x	x	x	x	
Healthy Climate® High Efficiency Air Filters 24 x 24 x 2 - order 6 per unit	MERV 11 - C1FLTR20C-1	97L87				⊗	⊗
	MERV 15 - C1FLTR50C-1	28W05				x	x
Replaceable Media Filter With Metal Mesh Frame (includes non-pleated filter media)	24 x 24 x 2 - C1FLTR30C order 2 per unit	44N61				x	x
Germicidal Lamps							
Healthy Climate® UVC Germicidal Lamps	208/230V - C1UVCL10B-1Y	X7521	x	x	x	x	
	460V - C1UVCL10B-1G	X7526	x	x	x	x	
	575V - C1UVCL10B-1J	X7531	x	x	x	x	
	208/230V - C1UVCL10C-1Y	X7521					x
	460V - C1UVCL10C-1G-1G	X7526					x
	575V - C1UVCL10C-1J	X7531					x
Indoor Air Quality Sensors							
CO ₂ Sensor - white case w/ display	C0SNSR50AE1L	77N39	x	x	x	x	x
CO ₂ Sensor - white case, no display	C0SNSR52AE1L	87N53	x	x	x	x	x
CO ₂ Sensor - black case w/ display	C0SNSR51AE1L	87N52	x	x	x	x	x
CO ₂ Sensor - black case, no display	C0SNSR53AE1L	87N54	x	x	x	x	x
CO ₂ Sensor Duct Mounting Kit	C0MISC19AE1-	85L43	x	x	x	x	x
Aspiration Box for duct mounting Sensor	C0MISC16AE1-	90N43	x	x	x	x	x
Handheld CO ₂ Monitor	LTAIAQSHM03/36	70N93	x	x	x	x	x
ECONOMIZER							
Economizer							
Economizer - Order Hood Separately	LAREMD10/15	53K51	⊗	⊗	⊗	⊗	
	LAREMD18/24	16K95				⊗	⊗
Outdoor Air Hood (down-flow) (Number of Filters) 16 x 25 x 1 in.	LAOAH10/15 (2)	53K05	⊗	⊗	⊗	⊗	
	C1HOOD10C-1 (3)	85M25				⊗	⊗
Economizer Controls							
Differential Enthalpy	C1SNSR07AE	86M33	⊗	⊗	⊗	⊗	⊗
Single Enthalpy	C1SNSR06AE	86M32	⊗	⊗	⊗	⊗	⊗
Global, Enthalpy	Sensor field provided	Factory	○	○	○	○	○
Differential Sensible	Furnished	Factory	○	○	○	○	○
Barometric Relief							
Down-Flow Barometric Relief Dampers - Order Hood Separately	LAGED10/15	53K03	⊗	⊗	⊗	⊗	
	LAGED18/24	16K98				⊗	⊗
Hood for Down-Flow LAGED	LAGEH09/15	88K79	x	x	x	x	
	C1HOOD20C-1	85M26				⊗	⊗
Horizontal Barometric Relief Dampers Hood Furnished	LAGEDH03/15	53K04	x	x	x	x	
	LAGEDH18/24	16K99				⊗	⊗

NOTE - The catalog and model numbers that appear here are for ordering field installed accessories only.

⊗ - Field Installed or Configure to Order (factory installed).

○ - Configure to Order (Factory Installed).

x - Field Installed.

OPTIONS / ACCESSORIES - LHA

Item	Catalog No.	090	102	120	150	180	240
OUTDOOR AIR							
Outdoor Air Dampers							
Damper Section down-flow Order Hood Separately	Motorized	LAOADM10/15	53K53	⊗	⊗	⊗	⊗
		LAOADM18/24	16K94			⊗	⊗
	Manual	LAOAD10/15	66K69	⊗	⊗	⊗	
		LAOAD18/24	16K93			⊗	⊗
Outdoor Air Hood (down-flow) (Number of Filters) - 16 x 25 x 1 in.		LAOAH10/15 (2)	53K05	⊗	⊗	⊗	
		C1HOOD10C-1 (3)	85M25			⊗	⊗
Power Exhaust							
Standard Static		208/230V - LAPEF10/15	73M32	⊗	⊗	⊗	⊗
		460V - LAPEF10/15	73M33	⊗	⊗	⊗	
		575V - LAPEF10/15	73M34	⊗	⊗	⊗	
		208/230V - C1PWRE20C-1Y	85M37			⊗	⊗
		460V - C1PWRE20C-1G	85M38			⊗	⊗
		575V - C1PWRE20C-1J	85M39			⊗	⊗
ROOF CURBS – CLIPLOCK 1000							
Down Flow							
8 in. height		C1CURB40BN1	26W31	x	x	x	x
		C1CURB40CN1	26W32			x	x
14 in. height		LARMF10/15S-14	65K34	x	x	x	x
		LARMF18/30S-14	33K44			x	x
18 in. height		LARMF10/15S-18	65K35	x	x	x	
		LARMF18/30S-18	33K45			x	x
24 in. height		LARMF10/15S-24	35K36	x	x	x	
		LARMF18/30S-24	33K46			x	x
Horizontal							
26 in. height - Slab Applications		LARMFH18/24-26	97J33			x	x
30 in. height - Slab Applications	(Canada Only)	LARMFH30/36S-30	45K71			x	x
37 in. height - Rooftop Applications		LARMFH18/24S-37	45K70			x	x
41 in. height - Rooftop Applications	(Canada Only)	LARMFH30/36S-30	45K72			x	x
Horizontal Supply Discharge Air Kit		LTHSDKGC10/15	56K53	x	x	x	x
		C1HAP10C-1	87M00			x	x
ROOF CURBS – STANDARD							
Down Flow							
14 in. height		LARMF10/15-14	53K50	x	x	x	x
		LARMF18/36-14	16K87			x	x
24 in. height		LARMF10/15-24	49K54	x	x	x	
		LARMF18/36-24	16K88			x	x
Horizontal							
26 in. height - Slab Applications	(Canada Only)	LARMFH18/24S-26	33K47			x	x
37 in. height - Rooftop Applications		LARMFH18/24-37	38K53			x	x
Insulation Kits							
for LARMFH18/24-26		C1INSU11C	73K32			x	x
for LARMFH18/24-37		C1INSU13C	73K34			x	x

NOTE - The catalog and model numbers that appear here are for ordering field installed accessories only.

⊗ - Field Installed or Configure to Order (factory installed)

X - Field Installed.

OPTIONS / ACCESSORIES - LHA

Item	Catalog No.	090	102	120	150	180	240	
CEILING DIFFUSERS								
Step-Down Order one	RTD11-95	29G04	x					
	(Canada Only) RTD11-95S	13K61	x					
	RTD11-135	29G05		x	x			
	(Canada Only) RTD11-135S	13K62		x	x			
	RTD11-185	29G06				x		
	(Canada Only) RTD11-150/180S	13K63				x		
	RTD11-185	29G06					x	
	(Canada Only) RTD11-150/180S	13K63					x	
	RTD11-275-R	29G07						x
	(Canada Only) RTD11-275S	13K64						x
Flush Order one	FD11-95	29G08	x					
	(Canada Only) FD11-95S	13K56	x					
	FD11-135	29G09		x	x			
	(Canada Only) FD11-135S	13K57		x	x			
	FD11-185	29G10				x		
	(Canada Only) FD11-150/180S	13K58				x		
	FD11-185	29G10					x	
	(Canada Only) FD11-150/180S	13K58					x	
	FD11-275-R	29G11						x
	(Canada Only) FD11-275S	13K59						x
Transitions (Supply and Return) Order one	LASRT08/10	24L14	x					
	LASRT10/12	49K55		x	x			
	(Canada Only) LASRT10/12S	65K37		x	x			
	LASRT15	49K56				x		
	LASRT15S	65K38				x		
	LASRT18	19K01					x	
	(Canada Only) LASRT18S	33K48					x	
	LASRT21/24	19K02						x
	(Canada Only) LASRT21/24S	33K49						x

NOTE - The catalog and model numbers that appear here are for ordering field installed accessories only.

X - Field Installed.

OPTIONAL ELECTRIC HEAT ACCESSORIES - LCA/LHA

ELECTRIC HEAT CONTROL MODULE AND UNIT FUSE BLOCKS													
Unit Model No.			LCA156H	LCA180S	LCA180H	LCA210S	LCA210H	LCA240S	LCA240H	LCA300S	LHA180H	LHA240H	
Electric Heat	Model No.		EHA (see Electric Heat Data tables for additional information)										
	kW Input Range	15	X	X	X	X	X	X	X	X	X	X	X
		30	X	X	X	X	X	X	X	X	X	X	X
		45	X	X	X	X	X	X	X	X	X	X	X
		60	X	X	X	X	X	X	X	X	X	X	X
	90	----	----	----	X	X	X	X	X	X	----	X	
Electric Heat Control Module (45/60/90 kW)			15K13 (208/230v), 15K92 (460v), 15K93 (575v)										
Unit Fuse Block (3 phase)	With Power Exhaust Fans	208/230v - 2 hp (1.5 kW)	56K95	----									
		460v - 2 hp (1.5 kW)	25K10	----									
		575v - 2 hp (1.5 kW)	25K08	----									
		208/230v - 3 hp (2.2 kW)	56K96	25K15				25K18		----	25K17	25K18	
		460v - 3 hp (2.2 kW)	25K10	25K11	25K13				----	25K11	25K13		
		575v - 3 hp (2.2 kW)	25K08	25K09	25K10				25K11	----	25K09	25K10	
		208/230v - 5 hp (3.7 kW)	56K96	25K17		25K18	25K17	25K18		25K19	25K17	25K18	
		460v - 5 hp (3.7 kW)	25K11	25K13			25K14		25K13	25K14	25K11	25K13	
		575v - 5 hp (3.7 kW)	25K09		25K10				25K11	25K13	25K10	25K11	
		208/230v - 7.5 hp (5.6 kW)	----	25K18		25K19	25K18	25K19			25K18	25K19	
		460v - 7.5 hp (5.6 kW)	----	25K13			25K14				25K13		
		575v - 7.5 hp (5.6 kW)	----	25K10	25K11	25K13	25K12	25K11	25K13		25K10	25K11	
		Unit Fuse Block (3 phase)	Without Power Exhaust Fans	208/230v - 2 hp (1.5 kW)	56K95	----							
460v - 2 hp (1.5 kW)	25K10			----									
575v - 2 hp (1.5 kW)	25K08			----									
208/230v - 3 hp (2.2 kW)	56K95			25K15				25K17	25K18	----	25K15	25K18	
460v - 3 hp (2.2 kW)	25K10			25K11				25K13		----	25K10	25K11	
575v - 3 hp (2.2 kW)	25K08			25K08	25K09				25K11	----	25K09	25K10	
208/230v - 5 hp (3.7 kW)	56K96			25K15	25K17			25K18		25K19	25K17	25K18	
460v - 5 hp (3.7 kW)	25K10			25K11	25K13			25K14		25K11	25K13		
575v - 5 hp (3.7 kW)	25K08			25K09	25K10				25K11		25K09	25K10	
208/230v - 7.5 hp (5.6 kW)	----			25K18				25K19			25K18		
460v - 7.5 hp (5.6 kW)	----			25K13			25K14				25K13		
575v - 7.5 hp (5.6 kW)	----			25K10	25K11				25K13		25K10	25K11	
LTB2 ELECTRIC HEAT TERMINAL BLOCK													
LTB2-175 (30K75) 175 amps, LTB2-335 (30K76) 335 amps													
(Required For Units Without Disconnect/Circuit Breaker But With Single Point Power Source)													
LTB2 Terminal Block (3 phase)	Unit Model No.		LCA156H	LCA180S	LCA180H	LCA210S	LCA210H	LCA240S	LCA240H	LCA300S	LHA180H	LHA240H	
	15 kW *208/230v 3ph	2 hp (1.5 kW)	----										
		3 hp (2.2 kW)	30K75	----									
		5 hp (3.7 kW)		30K75	30K75	30K75	30K75	30K75	30K75	30K75	30K75	30K75	
		7.5 hp (5.6 kW)		----									
	30 kW *208/230v 3ph	2 hp (1.5 kW)	----										
		3 hp (2.2 kW)	30K75	----									
		5 hp (3.7 kW)		30K75	30K75	30K75	30K75	30K75	30K75	30K75	30K75	30K75	
		7.5 hp (5.6 kW)		----									
	45 kW *208/230v 3ph	2 hp (1.5 kW)	----										
		3 hp (2.2 kW)	30K75	----									
		5 hp (3.7 kW)		30K75	30K75	30K75	30K75	30K75	30K75	30K75	30K75	30K75	
		7.5 hp (5.6 kW)		----									
	60 kW *208/230v 3ph	2 hp (1.5 kW)	----										
		3 hp (2.2 kW)	30K75	----									
		5 hp (3.7 kW)		30K75	30K75	30K75	30K75	30K75	30K75	30K75	30K75	30K75	
		7.5 hp (5.6 kW)		----	30K76	30K76							30K76
	90 kW *208/230v 3ph	3 hp (2.2 kW)	----			30K76	30K76	30K76	30K76	----	----	30K76	
		5 hp (3.7 kW)	----										
		7.5 hp (5.6 kW)	----										

NOTE — Terminal Block is factory installed in units with factory installed electric heat without disconnect/circuit breaker but with single point power source.

***NOTE — ALL 460V AND 575V UNIT VOLTAGES USE LTB2-175 (30K75) TERMINAL BLOCK.**

ELECTRICAL DATA LCA/LGA156/210

Model No.			LCA/LGA156H									LCA/LGA180								
Line voltage data — 60 Hz — 3 phase			208/230v			460v			575v			208/230v			460v			575v		
Condenser Fan Motors (4)	Full load amps - each (total)		2.4 (9.6)			1.3 (5.2)			1.0 (4.0)			2.4 (9.6)			1.3 (5.2)			1.0 (4.0)		
	Locked rotor amps - each (total)		4.7 (18.8)			2.3 (9.6)			1.9 (7.6)			4.7 (18.8)			2.3 (9.6)			1.9 (7.6)		
Evaporator Blower Motor	Motor Output	hp	2	3	5	2	3	5	2	3	5	3	5	7.5	3	5	7.5	3	5	7.5
		kW	1.5	2.2	3.7	1.5	2.2	3.7	1.5	2.2	3.7	2.2	3.7	5.6	2.2	3.7	5.6	2.2	3.7	5.6
	Full load amps		7.5	10.6	16.7	3.4	4.8	7.6	2.7	3.9	6.1	10.6	16.7	24.2	4.8	7.6	11.0	3.9	6.1	9.0
Locked rotor amps		46.9	66	105	20.4	26.8	45.6	16.2	23.4	36.6	66	105	152	26.8	45.6	66	23.4	36.6	54	
Optional Power Exhaust Fans	(No.) Horsepower (W)		(2) 1/3 (249)									(2) 1/3 (249)								
	Full load amps (total)		4.8			2.6			2.0			4.8			2.6			2.0		
	Locked rotor amps (total)		9.4			4.8			3.8			9.4			4.8			3.8		
Service Outlet (2) 115 volt GFCI (amp rating)			15			15			15			15			15			15		

LCA/LGA156H AND LCA/LGA180H MODELS

Compressors (3)	Rated load amps each (total)	13.5 (40.5)			7.4 (22.2)			5.8 (17.4)			17.3 (51.9)			9.0 (27.0)			7.1 (21.3)		
	Locked rotor amps each (total)	99 (297)			49.5 (148.5)			40 (120)			123.0 (369.0)			62.0 (186.0)			50.0 (150.00)		
Recommended maximum fuse size (amps)	With Exhaust Fans	70	80	80	40	40	45	30	30	35	90	100	110	50	50	50	40	40	45
	Less Exhaust Fans	70	70	80	40	40	40	30	30	30	90	100	110	45	50	50	35	40	45
†Minimum Circuit Ampacity	With Exhaust Fans	66	69	75	36	37	40	28	29	31	81	87	96	41	44	48	33	35	39
	Less Exhaust Fans	61	65	71	33	35	37	26	27	29	76	83	92	39	42	46	31	33	37

LCA/LGA180S MODEL

Compressors (3)	Rated load amps each (total)										16.7 (50.1)			8.6 (25.8)			6.0 (18.0)		
	Locked rotor amps each (total)										110.0 (330.0)			55.0 (165.0)			44.0 (132.0)		
Recommended maximum fuse size (amps)	With Exhaust Fans										90	100	110	45	50	50	35	35	40
	Less Exhaust Fans										90	90	110	45	45	50	30	35	40
†Minimum Circuit Ampacity	With Exhaust Fans										79	85	95	40	43	47	29	32	35
	Less Exhaust Fans										74	81	90	38	41	45	27	30	33

†Refer to National or Canadian Electrical Code manual to determine wire, fuse and disconnect size requirements.

NOTE — Extremes of operating range are plus and minus 10% of line voltage.

NOTE — Where current does not exceed 100 amps, HACR type circuit breaker may be used in place of fuse (U.S. only).

Model No.			LCA/LGA210								
Line voltage data — 60 Hz — 3 phase			208/230v			460v			575v		
Condenser Fan Motors (4)	Full load amps - each (total)		2.4 (9.6)			1.3 (5.2)			1.0 (4.0)		
	Locked rotor amps - each (total)		4.7 (18.8)			2.3 (9.6)			1.9 (7.6)		
Evaporator Blower Motor	Motor Output	hp	3	5	7.5	3	5	7.5	3	5	7.5
		kW	2.2	3.7	5.6	2.2	3.7	5.6	2.2	3.7	5.6
	Full load amps		10.6	16.7	24.2	4.8	7.6	11.0	3.9	6.1	9.0
Locked rotor amps		66	105	152	26.8	45.6	66	23.4	36.6	54	
Optional Power Exhaust Fans	(No.) Horsepower (W)		(2) 1/3 (249)								
	Full load amps (total)		4.8			2.6			2.0		
	Locked rotor amps (total)		9.4			4.8			3.8		
Service Outlet (2) 115 volt GFCI (amp rating)			15			15			15		

LCA/LGA210S MODELS

Compressors (4)	Rated load amps each (total)	14.0 (56.0)			7.0 (28.0)			5.8 (23.2)		
	Locked rotor amps each (total)	92.0 (368.0)			46.0 (184.0)			44.0 (176.0)		
Recommended maximum fuse size (amps)	With Exhaust Fans	90	100	125	50	50	60	40	40	50
	Less Exhaust Fans	90	100	110	45	50	60	35	40	45
†Minimum Circuit Ampacity	With Exhaust Fans	85	91	101	45	48	52	35	38	41
	Less Exhaust Fans	80	87	96	43	46	50	33	35	39

LCA/LGA210H MODELS

Compressors (4)	Rated load amps each (total)	13.5 (54.0)			7.4 (29.6)			5.8 (23.2)		
	Locked rotor amps each (total)	120.0 (480.0)			49.5 (198.0)			40.0 (160.0)		
Recommended maximum fuse size (amps)	With Exhaust Fans	90	100	110	50	50	60	40	40	45
	Less Exhaust Fans	90	100	110	45	50	60	35	40	45
†Minimum Circuit Ampacity	With Exhaust Fans	82	89	98	44	47	51	35	37	40
	Less Exhaust Fans	78	84	94	41	44	49	33	35	38

†Refer to National or Canadian Electrical Code manual to determine wire, fuse and disconnect size requirements.

NOTE — Extremes of operating range are plus and minus 10% of line voltage.

NOTE — Where current does not exceed 100 amps, HACR type circuit breaker may be used in place of fuse (U.S. only).

ELECTRICAL DATA - LCA/LGA240/300

Model No.		LCA/LGA300S											
Line voltage data — 60 Hz — 3 phase		208/230v			460v			575v					
Condenser Fan Motors (4)	Full load amps - each (total)	3 (12.0)			1.5 (6.0)			1.2 (4.8)					
	Locked rotor amps - each (total)	6 (24.0)			3 (12.0)			2.9 (11.6)					
EvaporatorBlower Motor	Motor Output	hp			5	7.5	10	5	7.5	10	5	7.5	10
		kW			3.7	5.6	7.5	3.7	5.6	7.5	3.7	5.6	7.5
	Full load amps	16.7	24.2	31	7.6	11.0	14	6.1	9.0	11			
	Locked rotor amps	105	152	193	45.6	66	84	36.6	54	66			
OptionalPower Exhaust Fans	(No.) Horsepower (W)	(2) 1/3 (249)											
	Full load amps (total)	4.8			2.6			2.0					
	Locked rotor amps (total)	9.4			4.8			3.8					
Service Outlet (2) 115 volt GFCI (amp rating)		15			15			15					
Compressors (4)	Locked rotor amps each (total)	156 (624)			70 (280)			54 (216)					
	Rated load amps each (total)	18.6 (74.4)			9.0 (36.0)			7.4 (29.6)					
Recommendedmaximum fuse size (amps)	With Exhaust Fans	125	125	150	60	60	70	50	50	60			
	Less Exhaust Fans	125	125	150	60	60	70	45	50	50			
†Minimum Circuit Ampacity	With Exhaust Fans	113	122	130	55	59	63	45	48	51			
	Less Exhaust Fans	108	117	125	52	56	60	43	46	49			

†Refer to National or Canadian Electrical Code manual to determine wire, fuse and disconnect size requirements.
 NOTE — Extremes of operating range are plus and minus 10% of line voltage.
 NOTE — Where current does not exceed 100 amps, HACR type circuit breaker may be used in place of fuse (U.S. only).

Model No.		LCA/LGA240H (R-22)									LCA/LGA240H (R-410A)								
Line voltage data - 60 Hz - 3 phase		208/230V			460V			575V			208/230V			460V			575V		
Compressors (4)	Rated load amps each (total)	17.3 (69.2)			9 (36)			7.1 (28.4)			20.5 (82)			9.6 (38.4)			7.6 (30.4)		
	Locked rotor amps each (total)	123 (492)			62 (248)			50 (200)			155 (620)			75 (300)			54 (216)		
Condenser Fan Motors (4)	Full load amps (total)	2.4 (9.6)			1.3 (5.2)			1 (4)			2.4 (9.6)			1.3 (5.2)			1 (4)		
	Locked rotor amps (total)	4.7 (18.8)			2.4 (9.6)			1.9 (7.6)			4.7 (18.8)			2.4 (9.6)			1.9 (7.6)		
Evaporator Blower Motor	Motor Output - hp	5	7.5	10	5	7.5	10	5	7.5	10	5	7.5	10	5	7.5	10	5	7.5	10
		kW	3.7	5.6	7.5	3.7	5.6	7.5	3.7	5.6	7.5	3.7	5.6	7.5	3.7	5.6	7.5	3.7	5.6
	Full load amps	16.7	24.2	30.8	7.6	11.0	14.0	6.1	9.0	11.0	16.7	24.2	30.8	7.6	11.0	14.0	6.1	9.0	11.0
	Locked rotor amps	105	152	193	45.6	66	84	36.6	54	66	105	152	193	45.6	66	84	36.6	54	66
1 Maximum Overcurrent Protection (amps)	With Exhaust Fans	110	125	150	60	60	70	45	50	50	125	150	150	60	70	70	50	50	60
	Less Exhaust Fans	110	125	125	60	60	70	45	50	50	125	125	150	60	60	70	50	50	50
†Minimum Circuit Ampacity	With Exhaust Fans	105	113	119	54	58	61	43	46	48	119	126	133	57	60	53	45	48	50
	Less Exhaust Fans	100	108	114	52	55	58	41	44	46	114	121	128	54	57	50	43	46	48
Optional Power Exhaust Fans	(No.) Horsepower (W)	(2) 1/3 (249)			(2) 1/3 (249)			(2) 1/3 (249)			(2) 1/3 (249)			(2) 1/3 (249)			(2) 1/3 (249)		
	Full load amps (total)	4.8			2.6			2.0			4.8			2.6			2.0		
	Locked rotor amps (total)	9.4			4.8			3.8			9.4			4.8			3.8		
Service Outlet (2) 115 volt GFCI (amp rating)		15			15			15			15			15			15		

NOTE - Extremes of operating range are plus and minus 10% of line voltage.
 1 HACR type breaker or fuse.
 2 Refer to National or Canadian Electrical Code manual to determine wire, fuse and disconnect size requirements.

**ELECTRICAL DATA - LHA180/240
Reciprocating Compressors**

Model No.		LHA180H									LHA240H												
Line voltage data — 60 Hz — 3 phase		208/230v			460v			575v			208/230v			460v			575v						
Unit Efficiency		High (H)									High (H)												
Compressors (2)	Rated load amps each (total)	23.9 (47.8)			10.6 (21.2)			8.7 (17.4)			27.6 (55.2)			11.6 (23.2)			10.4 (20.8)						
	Locked rotor amps each (total)	185.0 (370.0)			89.0 (178.0)			78.4 (156.8)			205.0 (410.0)			104.0 (208.0)			78.4 (156.8)						
Outdoor Coil Fan Motors (4)	Full load amps - each (total)	2.4 (9.6)			1.3 (5.2)			1.0 (4.0)			2.4 (9.6)			1.3 (5.2)			1.0 (4.0)						
	Locked rotor amps (total)	4.7 (18.8)			2.3 (9.6)			1.9 (7.6)			4.7 (18.8)			2.3 (9.6)			1.9 (7.6)						
Indoor Coil Blower Motor	Motor Output	hp	3	5	7.5	3	5	7.5	3	5	7.5	3	5	7.5	10	3	5	7.5	10	3	5	7.5	10
		kW	2.2	3.7	5.6	2.2	3.7	5.6	2.2	3.7	5.6	2.2	3.7	5.6	7.5	2.2	3.7	5.6	7.5	2.2	3.7	5.6	7.5
	Full load amps	10.6	16.7	24.2	4.8	7.6	11.0	3.9	6.1	9.0	10.6	16.7	24.2	30.8	4.8	7.6	11.0	14.0	3.9	6.1	9.0	11.0	
	Locked rotor amps	66	105	152	26.8	45.6	66	23.4	26.6	54	66	105	152	193	26.8	45.6	66	84	23.4	36.6	54	66	
Rec. max. fuse size (amps)	With Exhaust Fans	100	100	110	45	45	50	35	40	40	110	110	125	125	50	60	60	70	40	50	50	50	
	Less Exhaust Fans	90	100	110	40	45	50	35	35	40	110	110	110	125	45	60	60	60	40	45	50	50	
†Minimum Circuit Ampacity	With Exhaust Fans	79	85	92	36	39	42	29	32	35	87	99	107	113	38	51	54	57	33	40	43	45	
	Less Exhaust Fans	74	80	88	34	37	40	27	30	33	82	95	102	109	36	48	52	55	31	38	41	43	
Optional Power Exhaust Fans	(No.) Horsepower (W)	(2) 1/3 (249)																					
	Full load amps (total)	4.8			2.6			2.0			4.8			2.6			2.0						
	Locked rotor amps (total)	9.4			4.8			3.8			9.4			4.8			3.8						
Service Outlet (2) 115 volt GFCI (amp rating)	15																						

†Refer to National or Canadian Electrical Code manual to determine wire, fuse and disconnect size requirements.

NOTE — Extremes of operating range are plus and minus 10 % of line voltage.

NOTE — Where current does not exceed 100 amps, HACR type circuit breaker may be used in place of fuse (U.S. only).

**ELECTRICAL DATA - LHA180
Scroll Compressors**

Model No.		LHA180H								
Line voltage data - 60 Hz - 3 phase		208/230V			460V			575V		
Compressors	Number of Compressors	2			2			2		
	Rated load amps - each (total)	28.8 (57.6)			14.7 (29.4)			10.8 (21.6)		
	Locked rotor amps - each (total)	195 (390)			95 (190)			80 (160)		
Outdoor Fan Motors	Number of Motors	4			4			4		
	Full load amps - each (total)	2.4 (9.6)			1.3 (5.2)			1.0 (4.0)		
	Locked rotor amps - each (total)	4.7 (18.8)			2.4 (9.6)			1.9 (7.6)		
Indoor Blower Motor	Motor Output - hp	3	5	7.5	3	5	7.5	3	5	7.5
	- kW	2.2	3.7	5.6	2.2	3.7	5.6	2.2	3.7	5.6
	Full load amps	10.6	16.7	24.2	4.8	7.6	11.0	3.9	6.1	9.0
	Locked rotor amps	66	105	152	26.8	45.6	66	23.4	26.6	54
Recommended maximum fuse size (amps)	With Exhaust Fan	110	110	125	60	60	60	40	45	50
	Less Exhaust Fan	110	110	125	50	60	60	40	45	45
*Minimum Circuit Ampacity	With Exhaust Fan	90	96	104	46	49	52	35	37	40
	Less Exhaust Fan	86	92	99	44	46	50	33	35	38
Optional Power Exhaust Fan	(Number) Horsepower (W)	(2) 1/3 (249)			(2) 1/3 (249)			(2) 1/3 (249)		
	Full load amps	4.8			2.6			2.0		
	Locked rotor amps	9.4			4.8			3.8		
Service Outlet 115 volt GFCI (amp rating)	15									

†Refer to National or Canadian Electrical Code manual to determine wire, fuse and disconnect size requirements.

NOTE - Extremes of operating range are plus and minus 10 % of line voltage.

**ELECTRICAL DATA - LHA180
Scroll Compressors**

Model No.		LHA240H								
Line voltage data - 60 Hz - 3 phase		208/230V			460V			575V		
Compressors	Number of Compressors	2			2			2		
	Rated load amps - each (total)	30.1 (60.2)			15.5 (31.0)			12.1 (24.2)		
	Locked rotor amps - each (total)	225 (450)			114 (228)			80 (160)		
Outdoor Fan Motors (4)	Full load amps - each (total)	2.4 (9.6)			1.3 (5.2)			1.0 (4.0)		
	Locked rotor amps - each (total)	4.7 (18.8)			2.4 (9.6)			1.9 (7.6)		
Indoor Blower Motor	Motor Output - hp	5	7.5	10	5	7.5	10	5	7.5	10
	- kW	3.7	5.6	7.5	3.7	5.6	7.5	3.7	5.6	7.5
	Full load amps	16.7	24.2	30.8	7.6	11.0	14.0	6.1	9.0	11.0
	Locked rotor amps	105	152	193	45.6	66	84	36.6	54	66
Recommended maximum fuse size (amps)	With Exhaust Fan	125	125	125	60	60	70	50	50	50
	Less Exhaust Fan	110	125	125	60	60	60	45	50	50
*Minimum Circuit Ampacity	With Exhaust Fan	99	107	113	51	54	57	40	43	45
	Less Exhaust Fan	95	102	109	48	52	55	38	41	43
Optional Power Exhaust Fan	(Number) Horsepower (W)	(2) 1/3 (249)			(2) 1/3 (249)			(2) 1/3 (249)		
	Full load amps	4.8			2.6			2.0		
	Locked rotor amps	9.4			4.8			3.8		
Service Outlet 115 volt GFCI (amp rating)		15			15			15		

†Refer to National or Canadian Electrical Code manual to determine wire, fuse and disconnect size requirements.
NOTE - Extremes of operating range are plus and minus 10 % of line voltage.

BLOWER DATA

FACTORY INSTALLED DRIVE KIT SPECIFICATIONS

Motor Outputs				RPM Range								
Nominal hp	Maximum hp	Nominal kW	Maximum kW	Drive A	Drive 1	Drive 2	Drive 3	Drive 4	Drive 5	Drive 6	Drive 7	Drive 8
3 Std Eff	3.45	2.2	2.6	535-725	710-965	----	----	----	----	----	----	----
3 High Eff	3.45	2.2	2.6	----	----	685-865	----	----	----	----	----	----
5	5.75	3.7	4.3	----	----	685-865	850-1045	945-1185	----	----	----	----
7.5	8.63	5.6	6.4	----	----	----	----	----	945-1185	1045 - 1285	850-1045	----
10	11.5	7.5	8.6	----	----	----	----	----	----	1045 - 1285	----	1135 - 1365

NOTE - Using total air volume and system static pressure requirements determine from blower performance tables rpm and motor output required. Maximum usable output of motors furnished by Lennox are shown. In Canada, nominal motor output is also maximum usable motor output. If motors of comparable output are used, be sure to keep within the service factor limitations outlined on the motor nameplate.

MANUFACTURER'S NUMBERS

Drive No.	H.P.	DRIVE COMPONENTS									
		RPM		ADJUSTABLE SHEAVE		FIXED SHEAVE		BELTS		SPLIT BUSHING	
		Min	Max	Supplier No.	OEM Part No.	Supplier No.	OEM Part No.	Supplier No.	OEM Part No.	Supplier No.	OEM Part No.
A	2 & 3	535	725	1VP40x7/8	79J0301	BK95 x 1-7/16	80K1601	BX59	59A5001	N/A	N/A
1	3	710	965	1VP40x7/8	79J0301	BK72 x 1-7/16	100244-13	BX56	100245-11	N/A	N/A
2	3 & 5 High	685	865	1VP50x1-1/8	P-8-1977	BK100 x 1-7/16	39L1301	BX62	57A7701	N/A	N/A
3	5	850	1045	1VP65x1-1/8	100239-03	BK110H	100788-06	BX66	97J5901	H-1-7/16	49M6201
4	5	945	1185	1VP60x1-1/8	41C1301	BK90H x 1-7/16	100788-04	BX62	57A7701	H-1-7/16	49M6201
5	7.5	945	1185	1VP60x1-3/8	78L5501	BK90H x 1-7/16	100788-04	BX63	97J5501	H-1-7/16	49M6201
6	7.5	1045	1285	1VP65x1-3/8	78M7101	BK90H x 1-7/16	100788-04	BX64	97J5801	H-1-7/16	49M6201
6	10	1045	1285	1VP65x1-3/8	78M7101	1B5V86	78M8301	5VX760	100245-21	B-1-7/16	100246-01
7	7.5	850	1045	1VP65x1-3/8	78M7101	BK110H	100788-06	BX66	97J5901	H-1-7/16	49M6201
8	10	1135	1365	1VP65x1-3/8	78M7101	1B5V80	100240-05	5VX660	100245-20	B-1-7/16	100246-01

BLOWER DATA LGA UNITS

BLOWER TABLE INCLUDES RESISTANCE FOR BASE UNIT WITH STANDARD GAS HEAT, WET INDOOR COIL & AIR FILTERS IN PLACE. FOR ALL UNITS ADD:

- 1 - Any factory installed options air resistance (high gas heat, economizer, etc.). See table below
 - 2 - Any field installed accessories air resistance (duct resistance, diffuser, etc.). See Page 29
- Then determine from table the blower motor output and drive required.

0.30 to 1.40 in. w.g.

LGA156

Air Volume cfm	External Static (in. w.g.)																								
	0.30		0.40		0.50		0.60		0.70		0.80		0.90		1.00		1.10		1.20		1.30		1.40		
	RPM	BHP	RPM	BHP	RPM	BHP	RPM	BHP	RPM	BHP	RPM	BHP	RPM	BHP	RPM	BHP	RPM	BHP	RPM	BHP	RPM	BHP	RPM	BHP	RPM
	Low Static – 2 HP, Drive Kit A							Standard Static – 3 HP, Drive Kit 1																	
4160	551	0.90	596	1.04	641	1.18	681	1.33	720	1.48	755	1.64	790	1.80	822	1.95	855	2.11	885	2.26	915	2.41	942	2.57	
4400	561	0.97	606	1.14	651	1.30	689	1.45	727	1.60	762	1.77	797	1.94	830	2.11	862	2.28	892	2.43	922	2.58	950	2.75	
4800	577	1.13	620	1.31	662	1.48	702	1.66	742	1.83	777	2.01	811	2.18	842	2.36	872	2.54	902	2.72	932	2.89	960	3.07	
5200	593	1.33	636	1.51	678	1.68	716	1.88	754	2.07	789	2.27	823	2.46	856	2.66	888	2.86	916	3.04	944	3.21	972	3.41	
5600	609	1.51	652	1.71	694	1.91	732	2.12	769	2.33	803	2.53	837	2.73	868	2.93	899	3.13	928	3.33	957	3.53	985	3.74	
6000	630	1.75	670	1.95	710	2.15	748	2.38	785	2.60	818	2.83	850	3.05	880	3.25	910	3.45	940	3.68	970	3.90	998	4.13	
6240	640	1.89	680	2.12	720	2.34	757	2.57	795	2.79	827	3.02	860	3.24	890	3.47	920	3.69	947	3.92	975	4.14	1002	4.37	

NOTE - **Bold, italics** - drive is capable of the values noted but will exceed motor horsepower.

1.50 to 2.50 in. w.g.

LGA156

Air Volume cfm	External Static (in. w.g.)																					
	1.50		1.60		1.70		1.80		1.90		2.00		2.10		2.20		2.30		2.40		2.50	
	RPM	BHP	RPM	BHP	RPM	BHP	RPM	BHP	RPM	BHP	RPM	BHP	RPM	BHP	RPM	BHP	RPM	BHP	RPM	BHP	RPM	BHP
	High Static – 5 HP, Drive Kit 4										Field Furnished Drive											
4160	970	2.73	997	2.88	1023	3.03	1048	3.20	1073	3.38	1097	3.54	1120	3.71	1142	3.86	1165	4.01	1187	4.17	1208	4.33
4400	977	2.92	1003	3.07	1028	3.22	1053	3.40	1078	3.57	1103	3.76	1127	3.95	1150	4.10	1172	4.25	1193	4.42	1213	4.59
4800	987	3.24	1014	3.42	1041	3.60	1064	3.78	1087	3.95	1112	4.13	1136	4.30	1159	4.50	1181	4.70	1204	4.88	1226	5.06
5200	999	3.60	1024	3.78	1049	3.96	1074	4.16	1099	4.35	1124	4.55	1148	4.74	1171	4.94	1193	5.14	1214	5.34	1234	5.54
5600	1012	3.95	1037	4.15	1062	4.35	1087	4.57	1112	4.80	1135	5.00	1157	5.2	1180	5.41	1202	5.62	1223	5.83	1244	6.04
6000	1025	4.35	1050	4.58	1075	4.80	1098	5.00	1120	5.20	1145	5.43	1170	5.65	1193	5.88	1215	6.10	1235	6.33	1255	6.55
6240	1030	4.59	1055	4.82	1080	5.04	1105	5.26	1130	5.49	1152	5.71	1175	5.94	1197	6.19	1220	6.44	1242	6.66	1265	6.89

NOTE - **Bold, italics** - drive is capable of the values noted but will exceed motor horsepower.

AIR RESISTANCE (in. w.g.) - Factory Installed Options

Air Volume - cfm	Gas Heat Exchanger		Economizer	Horizontal Roof Curb	MERV 11 Filter
	Med. Heat	High Heat			
4160	.06	---	---	.07	.01
4400	.07	.09	---	.07	.01
4800	.08	.10	---	.08	.01
5000	.09	.11	---	.08	.01
5600	.10	.13	---	.10	.02
6000	.12	.15	---	.11	.02
6240	.12	.16	.01	.12	.02

**BLOWER TABLE INCLUDES RESISTANCE FOR BASE UNIT WITH STANDARD GAS HEAT, WET INDOOR COIL & AIR FILTERS IN PLACE.
FOR ALL UNITS ADD:**

1 - Any factory installed options air resistance (high gas heat, economizer, etc.). See table below

2 - Any field installed accessories air resistance (duct resistance, diffuser, etc.). See Page 29

Then determine from table the blower motor output and drive required.

0.30 to 1.40 in. w.g.

LGA180

Air Volume cfm	External Static (in. w.g.)																							
	0.30		0.40		0.50		0.60		0.70		0.80		0.90		1.00		1.10		1.20		1.30		1.40	
	RPM	BHP	RPM	BHP	RPM	BHP	RPM	BHP	RPM	BHP	RPM	BHP	RPM	BHP	RPM	BHP	RPM	BHP	RPM	BHP	RPM	BHP	RPM	BHP
	Low Static – 2 HP, Drive Kit A							Standard Static – 3 HP, Drive Kit 1																
4800	577	1.13	620	1.31	662	1.48	702	1.66	742	1.83	777	2.01	811	2.18	842	2.36	872	2.54	902	2.72	932	2.89	960	3.07
5000	585	1.25	628	1.43	670	1.60	710	1.78	750	1.95	783	2.13	815	2.30	848	2.50	880	2.70	910	2.88	940	3.05	968	3.23
5500	605	1.45	648	1.65	690	1.85	728	2.05	765	2.25	800	2.45	835	2.65	865	2.85	895	3.05	925	3.25	955	3.45	983	3.65
6000	630	1.75	670	1.95	710	2.15	748	2.38	785	2.60	818	2.83	850	3.05	880	3.25	910	3.45	940	3.68	970	3.90	998	4.13
6500	650	2.05	690	2.28	730	2.50	768	2.75	805	3.00	838	3.23	870	3.45	900	3.70	930	3.95	958	4.18	985	4.40	1013	4.63
7000	675	2.35	715	2.63	755	2.90	790	3.15	825	3.40	858	3.68	890	3.95	920	4.20	950	4.45	978	4.70	1005	4.95	1030	5.18
7200	687	2.55	725	2.81	763	3.06	798	3.33	833	3.60	866	3.86	898	4.11	926	4.36	954	4.61	984	4.90	1013	5.19	1038	5.44

1.50 to 2.50 in. w.g.

LGA180

Air Volume cfm	External Static (in. w.g.)																					
	1.50		1.60		1.70		1.80		1.90		2.00		2.10		2.20		2.30		2.40		2.50	
	RPM	BHP	RPM	BHP	RPM	BHP	RPM	BHP	RPM	BHP	RPM	BHP	RPM	BHP	RPM	BHP	RPM	BHP	RPM	BHP	RPM	BHP
	High Static – 5 HP, Drive Kit 4										Field Furnished Drive											
4800	987	3.24	1014	3.42	1041	3.60	1064	3.78	1087	3.95	1112	4.13	1136	4.30	1159	4.50	1181	4.70	1204	4.88	1226	5.06
5000	995	3.40	1020	3.60	1045	3.80	1070	3.98	1095	4.15	1118	4.33	1140	4.50	1163	4.70	1185	4.90	1208	5.10	1230	5.30
5500	1010	3.85	1035	4.05	1060	4.25	1085	4.48	1110	4.70	1133	4.90	1155	5.10	1178	5.30	1200	5.50	1220	5.70	1240	5.90
6000	1025	4.35	1050	4.58	1075	4.80	1098	5.00	1120	5.20	1145	5.43	1170	5.65	1193	5.88	1215	6.10	1235	6.33	1255	6.55
6500	1040	4.85	1065	5.10	1090	5.35	1115	5.60	1140	5.85	1163	6.08	1185	6.30	1205	6.53	1225	6.75	1248	7.00	1270	7.25
7000	1055	5.40	1080	5.68	1105	5.95	1130	6.20	1155	6.45	1178	6.70	1200	6.95	1220	7.20	1240	7.45	1263	7.73	1285	8.00
7200	1063	5.68	1088	5.94	1113	6.19	1136	6.44	1159	6.69	1182	6.96	1204	7.23	1226	7.50	1248	7.77	1269	8.03	1289	8.28

NOTE - **Bold, italics** - drive is capable of the values noted but will exceed motor horsepower.

AIR RESISTANCE (in. w.g.) - Factory Installed Options

Air Volume - cfm	Gas Heat Exchanger		Economizer	Horizontal Roof Curb	MERV 11 Filter
	Med. Heat	High Heat			
4800	.08	.10	---	.08	.01
5000	.09	.11	---	.08	.01
5500	.10	.13	---	.10	.02
6000	.12	.15	---	.11	.02
6500	.13	.17	.02	.13	.02
7000	.15	.19	.04	.15	.03
7200	.16	.20	.05	.16	.03

**BLOWER TABLE INCLUDES RESISTANCE FOR BASE UNIT WITH STANDARD GAS HEAT, WET INDOOR COIL & AIR FILTERS IN PLACE.
FOR ALL UNITS ADD:**

- 1 - Any factory installed options air resistance (high gas heat, economizer, etc.). See table below
- 2 - Any field installed accessories air resistance (duct resistance, diffuser, etc.). See Page 29

Then determine from table the blower motor output and drive required.

0.20 to 1.20 in. w.g.

LGA210

Air Volume cfm	External Static (in. w.g.)																					
	0.20		0.30		0.40		0.50		0.60		0.70		0.80		0.90		1.00		1.10		1.20	
	RPM	BHP	RPM	BHP	RPM	BHP	RPM	BHP	RPM	BHP	RPM	BHP	RPM	BHP	RPM	BHP	RPM	BHP	RPM	BHP	RPM	BHP
	Field Furnished				Low Static – 5 HP, Drive Kit 2								Standard Static – 5 HP, Drive Kit 3									
5600	609	1.51	652	1.71	694	1.91	732	2.12	769	2.33	803	2.53	837	2.73	868	2.93	899	3.13	928	3.33	957	3.53
6000	630	1.75	670	1.95	710	2.15	748	2.38	785	2.60	818	2.83	850	3.05	880	3.25	910	3.45	940	3.68	970	3.90
6500	650	2.05	690	2.28	730	2.50	768	2.75	805	3.00	838	3.23	870	3.45	900	3.70	930	3.95	958	4.18	985	4.40
7000	675	2.35	715	2.63	755	2.90	790	3.15	825	3.40	858	3.68	890	3.95	920	4.20	950	4.45	978	4.70	1005	4.95
7500	700	2.75	738	3.03	775	3.30	810	3.58	845	3.85	878	4.15	910	4.45	938	4.70	965	4.95	993	5.23	1020	5.50
8000	725	3.20	763	3.50	800	3.80	833	4.08	865	4.35	898	4.65	930	4.95	958	5.23	985	5.50	1013	5.80	1040	6.10
8400	746	3.55	783	3.87	819	4.18	853	4.49	886	4.80	916	5.12	946	5.43	974	5.73	1001	6.03	1029	6.35	1056	6.66

1.30 to 2.40 in. w.g.

LGA210

Air Volume cfm	External Static (in. w.g.)																							
	1.30		1.40		1.50		1.60		1.70		1.80		1.90		2.00		2.10		2.20		2.30		2.40	
	RPM	BHP	RPM	BHP	RPM	BHP	RPM	BHP	RPM	BHP	RPM	BHP	RPM	BHP	RPM	BHP	RPM	BHP	RPM	BHP	RPM	BHP	RPM	BHP
	Standard Static – 5 HP, Drive Kit 3							High Static – 7.5 HP, Drive Kit 6																
5600	985	3.74	1012	3.95	1037	4.15	1062	4.35	1087	4.58	1112	4.80	1135	5.00	1157	5.20	1180	5.41	1202	5.62	1223	5.83	1244	6.04
6000	998	4.13	1025	4.35	1050	4.58	1075	4.80	1098	5.00	1120	5.20	1145	5.43	1170	5.65	1193	5.88	1215	6.10	1235	6.33	1255	6.55
6500	1013	4.63	1040	4.85	1065	5.10	1090	5.35	1115	5.60	1140	5.85	1163	6.08	1185	6.30	1205	6.53	1225	6.75	1248	7.00	1270	7.25
7000	1030	5.18	1055	5.40	1080	5.68	1105	5.95	1130	6.20	1155	6.45	1178	6.70	1200	6.95	1220	7.20	1240	7.45	1263	7.73	1285	8.00
7500	1048	5.78	1075	6.05	1100	6.33	1125	6.60	1148	6.88	1170	7.15	1193	7.40	1215	7.65	1238	7.95	1260	8.25	1280	8.50	1300	8.75
8000	1065	6.40	1090	6.70	1115	6.98	1140	7.25	1163	7.55	1185	7.85	1208	8.13	1230	8.40	1253	8.70	1275	9.00	1295	9.30	1315	9.60
8400	1081	6.96	1106	7.26	1131	7.58	1156	7.89	1179	8.19	1201	8.49	1224	8.79	1246	9.09	1266	9.38	1286	9.67	1307	9.98	1328	10.29

NOTE - Bold, italics - drive is capable of the values noted but will exceed motor horsepower.
Italics - field furnished drive

AIR RESISTANCE (in. w.g.) - Factory Installed Options

Air Volume - cfm	Gas Heat Exchanger		Economizer	Horizontal Roof Curb	MERV 11 Filter
	Med. Heat	High Heat			
5600	.10	.13	---	.10	.02
6000	.12	.15	---	.11	.02
6500	.13	.17	.02	.13	.02
7000	.15	.19	.04	.15	.03
7500	.17	.21	.06	.17	.03
8000	.19	.24	.09	.19	.04
8400	.20	.26	.11	.21	.04

**BLOWER TABLE INCLUDES RESISTANCE FOR BASE UNIT WITH STANDARD GAS HEAT, WET INDOOR COIL & AIR FILTERS IN PLACE.
FOR ALL UNITS ADD:**

1 - Any factory installed options air resistance (high gas heat, economizer, etc.). See table below

2 - Any field installed accessories air resistance (duct resistance, diffuser, etc.). See Page 29

Then determine from table the blower motor output and drive required.

0.20 to 1.20 in. w.g.

LCA/LGA240

Air Volume cfm	External Static (in. w.g.)																					
	.20		0.30		0.40		0.50		0.60		0.70		0.80		0.90		1.00		1.10		1.20	
	RPM	BHP	RPM	BHP	RPM	BHP	RPM	BHP	RPM	BHP	RPM	BHP	RPM	BHP	RPM	BHP	RPM	BHP	RPM	BHP	RPM	BHP
	Low Static – 5 HP, Drive Kit 2 or 7.5 HP, Drive Kit 9						Standard Static – 7.5 HP, Drive Kit 7															
6400	648	1.99	688	2.22	727	2.46	764	2.69	801	2.92	834	3.15	866	3.39	896	3.62	926	3.85	954	4.08	981	4.30
7000	675	2.35	715	2.63	755	2.90	790	3.15	825	3.40	858	3.68	890	3.95	920	4.20	950	4.45	978	4.70	1005	4.95
7500	700	2.75	738	3.03	775	3.30	810	3.58	845	3.85	878	4.15	910	4.45	938	4.70	965	4.95	993	5.23	1020	5.50
8000	725	3.20	763	3.50	800	3.80	833	4.08	865	4.35	898	4.65	930	4.95	958	5.23	985	5.50	1013	5.80	1040	6.10
8500	750	3.65	788	3.98	825	4.30	858	4.60	890	4.90	920	5.23	950	5.55	978	5.85	1005	6.15	1033	6.48	1060	6.80
9000	780	4.20	815	4.53	850	4.85	880	5.18	910	5.50	940	5.83	970	6.15	998	6.48	1025	6.80	1053	7.15	1080	7.50
9600	811	4.87	845	5.22	879	5.57	910	5.94	941	6.31	970	6.67	999	7.02	1027	7.38	1054	7.74	1079	8.08	1104	8.41

1.30 to 2.40 in. w.g.

LCA/LGA240

Air Volume cfm	External Static (in. w.g.)																							
	1.30		1.40		1.50		1.60		1.70		1.80		1.90		2.00		2.10		2.20		2.30		2.40	
	RPM	BHP	RPM	BHP	RPM	BHP	RPM	BHP	RPM	BHP	RPM	BHP	RPM	BHP	RPM	BHP	RPM	BHP	RPM	BHP	RPM	BHP	RPM	BHP
	Standard Static				High Static – 10 HP, Drive Kit 6																			
6400	1008	4.53	1035	4.75	1060	4.98	1085	5.22	1110	5.45	1135	5.68	1157	5.91	1180	6.15	1202	6.40	1225	6.65	1246	6.88	1268	7.11
7000	1030	5.18	1055	5.40	1080	5.68	1105	5.95	1130	6.20	1155	6.45	1178	6.70	1200	6.95	1220	7.20	1240	7.45	1263	7.73	1285	8.00
7500	1048	5.78	1075	6.05	1100	6.33	1125	6.60	1148	6.88	1170	7.15	1193	7.40	1215	7.65	1238	7.95	1260	8.25	1280	8.50	1300	8.75
8000	1065	6.40	1090	6.70	1115	6.98	1140	7.25	1163	7.55	1185	7.85	1208	8.13	1230	8.40	1253	8.70	1275	9.00	1295	9.30	1315	9.60
8500	1085	7.10	1110	7.40	1135	7.73	1160	8.05	1183	8.35	1205	8.65	1228	8.95	1250	9.25	1270	9.55	1290	9.85	1310	10.15	1330	10.45
9000	1105	7.83	1130	8.15	1153	8.45	1175	8.75	1198	9.08	1220	9.40	1243	9.75	1265	10.10	1288	10.45	1310	10.80	1330	11.10	1350	11.40
9600	1129	8.77	1154	9.13	1177	9.46	1199	9.78	1222	10.14	1244	10.50	1267	10.87	1289	11.23	---	---	---	---	---	---		

NOTE - *italics* - field furnished drive.

AIR RESISTANCE (in. w.g.) - Factory or Field Installed Options

Air Volume - cfm	Gas Heat Exchanger		Economizer	Horizontal Roof Curb	Filters	
	Med. Heat	High Heat			MERV 11	MERV 15
6400	0.05	0.09	0.02	0.13	0.02	0.03
7000	0.06	0.10	0.04	0.15	0.03	0.03
7500	0.07	0.11	0.06	0.17	0.03	0.03
8000	0.08	0.13	0.09	0.19	0.04	0.03
8500	0.08	0.14	0.11	0.21	0.04	0.03
9000	0.10	0.16	0.14	0.24	0.04	0.04
9600	0.11	0.18	0.16	0.26	0.05	0.04

**BLOWER TABLE INCLUDES RESISTANCE FOR BASE UNIT WITH STANDARD GAS HEAT, WET INDOOR COIL & AIR FILTERS IN PLACE.
FOR ALL UNITS ADD:**

- 1 - Any factory installed options air resistance (high gas heat, economizer, etc.). See table below
- 2 - Any field installed accessories air resistance (duct resistance, diffuser, etc.). See Page 29

Then determine from table the blower motor output and drive required.

0.00 to 1.00 in. w.g.

LGA300S

Air Volume cfm	External Static (in. w.g.)																					
	0.00		0.10		0.20		0.30		0.40		0.50		0.60		0.70		0.80		0.90		1.00	
	RPM	BHP	RPM	BHP	RPM	BHP	RPM	BHP	RPM	BHP	RPM	BHP	RPM	BHP	RPM	BHP	RPM	BHP	RPM	BHP	RPM	BHP
	Low Static – 7.5 HP, Drive Kit 7																					
8000	725	3.20	763	3.50	800	3.80	833	4.08	865	4.35	898	4.65	930	4.95	958	5.23	985	5.50	1013	5.80	1040	6.10
8500	750	3.65	788	3.98	825	4.30	858	4.60	890	4.90	920	5.23	950	5.55	978	5.85	1005	6.15	1033	6.48	1060	6.80
9250	790	4.45	825	4.80	860	5.15	893	5.50	925	5.85	955	6.20	985	6.55	1013	6.88	1040	7.20	1065	7.53	1090	7.85
10000	835	5.40	868	5.78	900	6.15	930	6.50	960	6.85	988	7.23	1015	7.60	1043	7.98	1070	8.35	1095	8.70	1120	9.05
10750	875	6.40	908	6.83	940	7.25	970	7.65	1000	8.05	1028	8.45	1055	8.85	1080	9.25	1105	9.65	1130	10.05	1155	10.45
11500	915	7.40	948	7.88	980	8.35	1010	8.80	1040	9.25	1068	9.68	1095	10.10	1118	10.53	1140	10.95	1165	11.40	1190	11.85

NOTE - **Bold, italics** - drive is capable of the values noted but will exceed motor horsepower.

1.10 to 2.20 in. w.g.

LGA300S

Air Volume cfm	External Static (in. w.g.)																							
	1.10		1.20		1.30		1.40		1.50		1.60		1.70		1.80		1.90		2.00		2.10		2.20	
	RPM	BHP	RPM	BHP	RPM	BHP	RPM	BHP	RPM	BHP	RPM	BHP	RPM	BHP	RPM	BHP	RPM	BHP	RPM	BHP	RPM	BHP	RPM	BHP
	Standard Static – 10 HP, Drive Kit 6												Field Furnished Drive											
8000	1065	6.40	1090	6.70	1115	6.98	1140	7.25	1163	7.55	1185	7.85	1208	8.13	1230	8.40	1253	8.70	1275	9.00	1295	9.30	1315	9.60
8500	1085	7.10	1110	7.40	1135	7.73	1160	8.05	1183	8.35	1205	8.65	1228	8.95	1250	9.25	1270	9.55	1290	9.85	1310	10.15	1330	10.45
9250	1115	8.20	1140	8.55	1163	8.88	1185	9.20	1208	9.53	1230	9.85	1253	10.20	1275	10.55	1295	10.88	1315	11.20	---	---	---	---
10000	1145	9.43	1170	9.80	1193	10.15	1215	10.50	1238	10.88	1260	11.25	1283	11.62	---	---	---	---	---	---	---	---	---	---
10750	1178	10.83	1200	11.20	1222	11.57	---	---	---	---	---	---	---	---	---	---	---	---	---	---	---	---	---	---
11500	1210	12.23	1230	12.60	---	---	---	---	---	---	---	---	---	---	---	---	---	---	---	---	---	---	---	---

NOTE - **Bold, italics** - drive is capable of the values noted but will exceed motor horsepower.

AIR RESISTANCE (in. w.g.) - Factory Installed Options

Air Volume - cfm	Gas Heat Exchanger		Economizer	Horizontal Roof Curb	MERV 11 Filter
	Med. Heat	High Heat			
8000	.19	.24	.09	.13	.04
8500	.20	.26	.11	.15	.04
9250	.24	.30	.15	.18	.05
10,000	.27	.35	.19	.21	.06

BLOWER DATA LCA UNITS

BLOWER TABLE INCLUDES RESISTANCE FOR BASE UNIT ONLY WITH DRY INDOOR COIL & AIR FILTERS IN PLACE.

FOR ALL UNITS ADD:

- 1 - Wet indoor coil air resistance of selected unit.
- 2 - Any factory installed options air resistance (heat section, economizer, etc.)
- 3 - Any field installed accessories air resistance (duct resistance, diffuser, etc.)

Then determine from blower table blower motor output and drive required.

See Page 28 for wet coil and option/accessory air resistance data.

See Page 20 for factory installed drive kit specifications.

BOLD INDICATES FIELD FURNISHED DRIVE

Air Volume cfm (L/s)	TOTAL STATIC PRESSURE — Inches Water Gauge (Pa)																											
	.20 (50)		.40 (100)		.60 (150)		.80 (200)		1.00 (250)		1.20 (300)		1.40 (350)		1.60 (400)		1.80 (450)		2.00 (495)		2.20 (545)		2.40 (595)		2.60 (645)			
	RPM	BHP (kW)	RPM	BHP (kW)	RPM	BHP (kW)	RPM	BHP (kW)	RPM	BHP (kW)	RPM	BHP (kW)	RPM	BHP (kW)	RPM	BHP (kW)	RPM	BHP (kW)	RPM	BHP (kW)	RPM	BHP (kW)	RPM	BHP (kW)	RPM	BHP (kW)	RPM	BHP (kW)
6000 (2830)	---		435	1.20 (0.90)	525	1.45 (1.08)	570	1.60 (1.19)	630	2.00 (1.49)	700	2.35 (1.75)	750	2.80 (2.09)	795	3.15 (2.35)	840	3.40 (2.54)	880	3.80 (2.83)	920	4.20 (3.13)	960	4.65 (3.47)	995	5.10 (3.80)		
6500 (3065)	---		445	1.30 (0.97)	530	1.60 (1.19)	580	1.80 (1.34)	640	2.20 (1.64)	705	2.60 (1.94)	755	3.05 (2.28)	800	3.40 (2.54)	845	3.70 (2.76)	885	4.15 (3.10)	925	4.60 (4.43)	965	5.00 (3.73)	1000	5.45 (4.07)		
7000 (3305)	---		455	1.40 (1.04)	535	1.75 (1.31)	590	2.05 (1.53)	650	2.45 (1.83)	710	2.85 (2.13)	760	3.30 (2.46)	805	3.70 (2.76)	850	4.05 (3.02)	890	4.50 (3.36)	930	4.95 (3.69)	970	5.40 (4.03)	1005	5.85 (4.36)		
7500 (3540)	380	1.05 (0.78)	465	1.50 (1.12)	540	1.90 (1.42)	600	2.30 (1.72)	660	2.70 (2.01)	715	3.15 (2.35)	765	3.60 (2.69)	810	4.00 (2.98)	855	4.45 (3.32)	895	4.90 (3.66)	935	5.35 (3.99)	975	5.85 (4.36)	1010	6.30 (4.70)		
8000 (3775)	390	1.25 (0.93)	475	1.65 (1.23)	545	2.10 (1.57)	610	2.55 (1.90)	665	2.95 (2.20)	720	3.45 (2.57)	770	3.90 (2.91)	815	4.35 (3.25)	860	4.85 (3.62)	900	5.30 (3.95)	940	5.75 (4.29)	980	6.30 (4.70)	1015	6.75 (5.04)		
8500 (4010)	405	1.40 (1.04)	485	1.90 (1.42)	555	2.35 (1.75)	620	2.80 (2.09)	675	3.30 (2.46)	725	3.75 (2.80)	775	4.20 (3.13)	820	4.70 (3.51)	865	5.20 (3.88)	905	5.70 (4.25)	945	6.20 (4.63)	985	6.75 (5.04)	1020	7.25 (5.41)		
9000 (4245)	415	1.60 (1.19)	495	2.10 (1.57)	565	2.60 (1.94)	625	3.10 (2.31)	685	3.60 (2.69)	735	4.10 (3.06)	785	4.60 (3.43)	830	5.10 (3.80)	870	5.60 (4.18)	915	6.15 (4.59)	955	6.70 (5.00)	990	7.20 (5.37)	1025	7.70 (5.74)		
9500 (4485)	430	1.85 (1.38)	505	2.35 (1.75)	575	2.90 (2.16)	635	3.40 (2.54)	690	3.90 (2.91)	745	4.50 (3.36)	790	4.95 (3.69)	835	5.50 (4.10)	880	6.05 (4.51)	920	6.60 (4.92)	960	7.15 (5.33)	995	7.70 (5.74)	1035	8.30 (6.19)		
10,000 (4720)	445	2.10 (1.57)	520	2.65 (1.98)	585	3.20 (2.39)	645	3.75 (2.80)	700	4.30 (3.21)	750	4.85 (6.49)	800	5.40 (4.03)	845	5.95 (4.44)	885	6.50 (4.85)	925	7.05 (5.26)	965	7.65 (5.71)	1000	8.20 (6.12)	1040	8.85 (6.60)		
10,500 4955)	455	2.35 (1.75)	530	2.95 (2.20)	595	3.50 (2.61)	655	4.10 (3.06)	710	4.70 (3.03)	760	5.25 (3.92)	805	5.80 (4.33)	850	6.40 (4.77)	895	7.00 (5.22)	935	7.60 (5.67)	970	8.15 (6.08)	1010	8.80 (6.56)	1045	9.40 (7.01)		
11,000 (5190)	470	2.60 (1.94)	545	3.25 (2.42)	605	3.85 (2.87)	665	4.45 (3.32)	720	5.10 (3.80)	765	5.66 (4.22)	815	6.30 (4.70)	860	6.90 (5.15)	900	7.50 (5.60)	940	8.10 (6.04)	980	8.75 (6.53)	1015	9.35 (6.98)	---	---		
11,500 (5425)	485	2.95 (2.20)	555	3.60 (2.69)	620	4.25 (3.17)	675	4.85 (3.62)	730	5.55 (4.14)	775	6.10 (4.55)	820	6.70 (5.00)	865	7.40 (5.52)	910	8.05 (6.01)	945	8.65 (6.45)	985	9.30 (6.94)	1020	9.95 (7.42)	---	---		
12,000 (5665)	500	3.30 (2.46)	570	4.00 (2.98)	630	4.65 (3.47)	685	5.30 (3.95)	740	6.00 (4.48)	785	6.60 (4.92)	830	7.25 (5.41)	875	7.95 (5.93)	915	8.60 (6.42)	955	9.25 (6.90)	995	9.95 (7.42)	1030	10.60 (7.91)	---	---		
12,500 (5900)	515	3.65 (2.72)	580	4.35 (3.25)	640	5.05 (3.77)	695	5.75 (4.29)	750	6.50 (4.85)	795	7.10 (5.30)	840	7.80 (5.82)	885	8.55 (6.38)	925	9.20 (6.86)	965	9.90 (7.39)	1000	10.55 (7.87)	1035	11.25 (8.39)	---	---		
13,000 (6135)	530	4.05 (3.02)	595	4.80 (3.58)	655	5.55 (4.14)	710	6.25 (4.66)	760	7.00 (5.22)	805	7.65 (5.71)	850	8.40 (6.27)	890	9.05 (6.75)	930	9.75 (7.27)	970	10.50 (7.83)	1010	11.30 (8.43)	---	---	---	---		
13,500 (6370)	545	4.45 (3.32)	610	5.25 (3.92)	665	6.00 (4.48)	720	6.75 (5.04)	770	7.50 (5.60)	815	8.25 (6.15)	860	9.00 (6.71)	900	9.70 (7.24)	940	10.45 (7.80)	980	11.20 (8.36)	---	---	---	---	---	---		
14,000 (6605)	560	4.90 (3.66)	620	5.70 (4.25)	680	6.55 (4.89)	730	7.30 (5.45)	780	8.10 (6.04)	825	8.85 (6.60)	870	9.65 (7.20)	910	10.40 (7.76)	950	11.15 (8.31)	---	---	---	---	---	---	---	---		
14,500 (6845)	575	5.40 (4.03)	635	6.25 (4.66)	690	7.05 (5.26)	745	7.90 (5.89)	790	8.65 (6.45)	835	9.45 (7.05)	880	10.30 (7.68)	920	11.10 (8.28)	---	---	---	---	---	---	---	---	---	---		
15,000 (7080)	590	5.90 (4.40)	650	6.80 (5.07)	705	7.65 (5.71)	755	8.50 (6.34)	800	9.30 (6.94)	845	10.10 (7.53)	890	11.00 (8.21)	---	---	---	---	---	---	---	---	---	---	---	---		

BLOWER DATA LHA UNITS

15 and 20 TON (180 and 240)

BLOWER TABLE INCLUDES RESISTANCE FOR BASE UNIT ONLY WITH DRY INDOOR COIL & AIR FILTERS IN PLACE.

FOR ALL UNITS ADD:

- 1 - Wet indoor coil air resistance of selected unit.
- 2 - Any factory installed options air resistance (heat section, economizer, etc.)
- 3 - Any field installed accessories air resistance (duct resistance, diffuser, etc.)

Then determine from blower table blower motor output and drive required.

See Page 28 for wet coil and option/accessory air resistance data.

See Page 20 for factory installed drive kit specifications.

MINIMUM AIR VOLUME REQUIRED FOR USE WITH OPTIONAL ELECTRIC HEAT

- Units with 15, 22.5, 30 or 45 kW electric heat require 6400 cfm (3020 L/s) minimum air.
- Units with 60 or 90 kW electric heat require 7000 cfm (3305 L/s) minimum air.

Air Volume cfm (L/s)	TOTAL STATIC PRESSURE - Inches Water Gauge (Pa)																							
	.40 (100)		.60 (150)		.80 (200)		1.00 (250)		1.20 (300)		1.40 (350)		1.60 (400)		1.80 (450)		2.00 (495)		2.20 (545)		2.40 (595)		2.60 (645)	
	RPM	BHP (kW)	RPM	BHP (kW)	RPM	BHP (kW)	RPM	BHP (kW)	RPM	BHP (kW)	RPM	BHP (kW)	RPM	BHP (kW)	RPM	BHP (kW)	RPM	BHP (kW)	RPM	BHP (kW)	RPM	BHP (kW)	RPM	BHP (kW)
4000 (1890)	545	0.85 (0.63)	635	1.10 (0.82)	715	1.40 (1.04)	785	1.70 (1.27)	850	2.00 (1.49)	910	2.30 (1.72)	965	2.60 (1.94)	1020	2.90 (2.16)	1070	3.25 (2.42)	1115	3.55 (2.65)	1160	3.85 (2.87)	1205	4.15 (3.10)
4250 (2005)	555	0.90 (0.67)	645	1.25 (0.93)	725	1.55 (1.16)	795	1.85 (1.38)	855	2.15 (1.60)	915	2.45 (1.83)	970	2.80 (2.09)	1025	3.10 (2.31)	1075	3.45 (2.57)	1120	3.75 (2.80)	1165	4.10 (3.06)	1210	4.45 (3.32)
4500 (2125)	565	1.00 (0.75)	655	1.35 (1.01)	730	1.65 (1.23)	800	2.00 (1.49)	865	2.35 (1.75)	925	2.65 (1.98)	980	3.00 (2.24)	1030	3.30 (2.46)	1080	3.65 (2.72)	1130	4.05 (3.02)	1175	4.35 (3.25)	1215	4.70 (3.51)
4750 (2240)	575	1.10 (0.82)	660	1.45 (1.08)	740	1.80 (1.34)	810	2.15 (1.60)	870	2.50 (1.87)	930	2.85 (2.13)	985	3.20 (2.39)	1040	3.55 (2.65)	1085	3.90 (2.91)	1135	4.25 (3.17)	1180	4.65 (3.47)	1225	5.00 (3.73)
5000 (2360)	585	1.25 (0.93)	670	1.60 (1.19)	750	1.95 (1.45)	815	2.30 (1.72)	880	2.70 (2.01)	940	3.05 (2.28)	995	3.40 (2.54)	1045	3.80 (2.83)	1095	4.15 (3.10)	1140	4.50 (3.36)	1185	4.90 (3.66)	1230	5.30 (3.95)
5250 (2475)	595	1.35 (1.01)	680	1.70 (1.27)	755	2.10 (1.57)	825	2.50 (1.87)	890	2.90 (2.16)	945	3.25 (2.42)	1000	3.65 (2.72)	1050	4.00 (2.98)	1100	4.40 (3.28)	1150	4.80 (3.58)	1195	5.20 (3.88)	1235	5.60 (4.18)
5500 (2595)	605	1.45 (1.08)	690	1.85 (1.38)	765	2.25 (1.68)	835	2.65 (1.98)	895	3.05 (2.28)	955	3.45 (2.57)	1010	3.85 (2.87)	1060	4.25 (3.17)	1110	4.70 (3.51)	1155	5.10 (3.80)	1200	5.50 (4.10)	1240	5.90 (4.40)
5750 (2715)	615	1.60 (1.19)	700	2.00 (1.49)	775	2.45 (1.83)	840	2.85 (2.13)	905	3.25 (2.42)	960	3.65 (2.72)	1015	4.10 (3.06)	1065	4.50 (3.36)	1115	4.95 (3.69)	1160	5.35 (3.99)	1205	5.80 (4.33)	1250	6.25 (4.66)
6000 (2830)	630	1.75 (1.31)	710	2.15 (1.60)	785	2.60 (1.94)	850	3.05 (2.28)	910	3.45 (2.57)	970	3.90 (2.91)	1025	4.35 (3.25)	1075	4.80 (3.58)	1120	5.20 (3.88)	1170	5.65 (4.21)	1215	6.10 (4.55)	1255	6.55 (4.89)
6250 (2950)	640	1.90 (1.42)	720	2.35 (1.75)	795	2.80 (2.09)	860	3.25 (2.42)	920	3.70 (2.76)	975	4.15 (3.10)	1030	4.60 (3.43)	1080	5.05 (3.77)	1130	5.50 (4.10)	1175	5.95 (4.44)	1220	6.45 (4.81)	1265	6.90 (5.15)
6500 (3065)	650	2.05 (1.53)	730	2.50 (1.87)	805	3.00 (2.24)	870	3.45 (2.57)	930	3.95 (2.95)	985	4.40 (3.28)	1040	4.85 (3.62)	1090	5.35 (3.99)	1140	5.85 (4.36)	1185	6.30 (4.70)	1225	6.75 (5.04)	1270	7.25 (5.41)
6750 (3185)	665	2.20 (1.64)	745	2.70 (2.01)	815	3.20 (2.39)	880	3.70 (2.76)	940	4.20 (3.13)	995	4.65 (3.47)	1045	5.10 (3.80)	1095	5.60 (4.18)	1145	6.10 (4.55)	1190	6.60 (4.92)	1235	7.10 (5.30)	1275	7.60 (5.67)
7000 (3305)	675	2.35 (1.75)	755	2.90 (2.16)	825	3.40 (2.54)	890	3.95 (2.95)	950	4.45 (3.32)	1005	4.95 (3.69)	1055	5.40 (4.03)	1105	5.95 (4.44)	1155	6.45 (4.81)	1200	6.95 (5.18)	1240	7.45 (5.56)	1285	8.00 (5.97)
7250 (3420)	690	2.60 (1.94)	765	3.10 (2.31)	835	3.65 (2.72)	900	4.15 (3.10)	955	4.65 (3.47)	1015	5.25 (3.92)	1065	5.75 (4.29)	1115	6.25 (4.66)	1160	6.75 (5.04)	1205	7.30 (5.45)	1250	7.85 (5.86)	1290	8.35 (6.23)
7500 (3540)	700	2.75 (2.05)	775	3.30 (2.46)	845	3.85 (2.87)	910	4.45 (3.32)	965	4.95 (3.69)	1020	5.50 (4.10)	1075	6.05 (4.51)	1125	6.60 (4.92)	1170	7.15 (5.33)	1215	7.65 (5.71)	1260	8.25 (6.15)	1300	8.75 (6.53)
7750 (3655)	715	3.00 (2.24)	790	3.55 (2.65)	855	4.10 (3.06)	920	4.70 (3.51)	975	5.25 (3.92)	1030	5.80 (4.33)	1080	6.35 (4.74)	1130	6.90 (5.15)	1180	7.50 (5.60)	1225	8.05 (6.01)	1265	8.60 (6.42)	1305	9.15 (6.83)
8000 (3775)	725	3.20 (2.39)	800	3.80 (2.83)	865	4.35 (3.25)	930	4.95 (3.69)	985	5.50 (4.10)	1040	6.10 (4.55)	1090	6.70 (5.00)	1140	7.25 (5.41)	1185	7.85 (5.86)	1230	8.40 (6.27)	1275	9.00 (6.71)	1315	9.60 (7.16)
8250 (3895)	740	3.40 (2.54)	810	4.00 (2.98)	880	4.65 (3.47)	940	5.25 (3.92)	995	5.85 (4.36)	1050	6.45 (4.81)	1100	7.05 (5.26)	1150	7.65 (5.71)	1195	8.25 (6.15)	1240	8.85 (6.60)	1280	9.40 (7.01)	1325	10.05 (7.50)
8500 (4010)	750	3.65 (2.72)	825	4.30 (3.21)	890	4.90 (3.66)	950	5.55 (4.14)	1005	6.15 (4.59)	1060	6.80 (5.07)	1110	7.40 (5.52)	1160	8.05 (6.01)	1205	8.65 (6.45)	1250	9.25 (6.90)	1290	9.85 (7.35)	1330	10.45 (7.80)
8750 (4130)	765	3.90 (2.91)	835	4.55 (3.39)	900	5.20 (3.88)	960	5.85 (4.36)	1015	6.45 (4.81)	1070	7.15 (5.33)	1120	7.75 (5.78)	1165	8.35 (6.23)	1215	9.05 (6.75)	1255	9.65 (7.20)	1300	10.30 (7.68)	1340	10.90 (8.13)
9000 (4245)	780	4.20 (3.13)	850	4.85 (3.62)	910	5.50 (4.10)	970	6.15 (4.59)	1025	6.80 (5.07)	1080	7.50 (5.60)	1130	8.15 (6.08)	1175	8.75 (6.53)	1220	9.40 (7.01)	1265	10.10 (7.53)	1310	10.80 (8.06)	1350	11.40 (8.50)
9250 (4365)	790	4.45 (3.32)	860	5.15 (3.84)	925	5.85 (4.36)	985	6.55 (4.89)	1040	7.20 (5.37)	1090	7.85 (5.86)	1140	8.55 (6.38)	1185	9.20 (6.86)	1230	9.85 (7.35)	1275	10.55 (7.87)	1315	11.20 (8.36)	---	---
9500 (4485)	805	4.75 (3.54)	875	5.45 (4.07)	935	6.15 (4.59)	995	6.90 (5.15)	1050	7.60 (5.67)	1100	8.25 (6.15)	1150	8.95 (6.68)	1195	9.60 (7.16)	1240	10.30 (7.68)	1285	11.05 (8.24)	---	---	---	---
9750 (4600)	820	5.05 (3.77)	885	5.75 (4.29)	950	6.55 (4.89)	1005	7.20 (5.37)	1060	7.95 (5.93)	1110	8.65 (6.45)	1160	9.40 (7.01)	1205	10.05 (7.50)	1250	10.80 (8.06)	1295	11.50 (8.58)	---	---	---	---
10000 (4720)	835	5.40 (4.03)	900	6.15 (4.59)	960	6.85 (5.11)	1015	7.60 (5.67)	1070	8.35 (6.23)	1120	9.05 (6.75)	1170	9.80 (7.31)	1215	10.50 (7.83)	1260	11.25 (8.39)	---	---	---	---	---	---
10250 (4835)	845	5.65 (4.21)	910	6.45 (4.81)	970	7.20 (5.37)	1030	8.00 (5.97)	1080	8.75 (6.53)	1135	9.55 (7.12)	1180	10.25 (7.65)	1225	11.00 (8.21)	---	---	---	---	---	---	---	---
10500 (4955)	860	6.00 (4.48)	925	6.85 (5.11)	985	7.65 (5.71)	1040	8.40 (6.27)	1095	9.20 (6.86)	1145	10.00 (7.46)	1190	10.70 (7.98)	1235	11.45 (8.54)	---	---	---	---	---	---	---	---
10750 (5075)	875	6.40 (4.77)	940	7.25 (5.41)	1000	8.05 (6.01)	1055	8.85 (6.60)	1105	9.65 (7.20)	1155	10.45 (7.80)	1200	11.20 (8.36)	---	---	---	---	---	---	---	---	---	---
11000 (5190)	890	6.80 (5.07)	950	7.60 (5.67)	1010	8.45 (6.30)	1065	9.30 (6.94)	1115	10.05 (7.50)	1165	10.90 (8.13)	---	---	---	---	---	---	---	---	---	---	---	---

BLOWER DATA LCA & LHA UNITS

AIR RESISTANCE - OPTIONS

Air Volume cfm	Total Resistance - in. w.g.												LARMFH18/24 Horizontal Roof Curb 180, 240
	Wet Indoor Coil				Electric Heat		Economizer		Filters				
	090, 102	120, 150	180	240	090, 102, 120, 150	180, 240	090, 102, 120, 150	180, 240	MERV 11		MERV 15		
	090, 102	120, 150	180	240	090, 102, 120, 150	180, 240	090, 102, 120, 150	180, 240	090, 102, 120, 150	180, 240	090, 102, 120, 150	180, 240	180, 240
2250	.06	.10	---	---	.01	---	.03	---	.01	---	0.04	---	---
2500	.08	.12	---	---	.01	---	.04	---	.01	---	0.05	---	---
2750	.09	.14	---	---	.01	---	.04	---	.02	---	0.05	---	---
3000	.10	.16	---	---	.02	---	.05	---	.02	---	0.06	---	---
3250	.11	.19	---	---	.02	---	.06	---	.02	---	0.06	---	---
3500	.13	.21	---	---	.03	---	.07	---	.03	---	0.07	---	---
3750	.14	.23	---	---	.03	---	.07	---	.03	---	0.08	---	---
4000	.16	.26	.04	.07	.04	.01	.08	.05	.04	.01	0.08	---	.06
4250	.17	.28	.04	.07	.04	.01	.09	.05	.04	.01	0.09	---	.07
4500	.18	.31	.04	.08	.05	.01	.10	.05	.04	.01	0.09	---	.07
4750	.20	.33	.05	.09	.05	.01	.11	.05	.05	.01	0.10	0.02	.08
5000	.22	.36	.05	.10	.06	.01	.12	.06	.06	.01	0.10	0.02	.08
5250	.24	.39	.06	.10	.06	.02	.13	.06	.06	.02	0.11	0.02	.09
5500	.26	.42	.06	.11	.07	.02	.14	.06	.07	.02	0.12	0.02	.10
5750	.28	.45	.06	.12	.07	.02	.15	.07	.07	.02	0.12	0.03	.11
6000	.30	.48	.07	.13	.08	.02	.16	.07	.08	.02	0.13	0.03	.11
6250	---	---	.07	.14	---	.02	---	.08	---	.02	---	0.03	.12
6500	---	---	.08	.14	---	.03	---	.08	---	.02	---	0.03	.13
6750	---	---	.08	.15	---	.03	---	.08	---	.02	---	0.03	.14
7000	---	---	.09	.16	---	.03	---	.09	---	.03	---	0.03	.15
7250	---	---	.09	.17	---	.03	---	.09	---	.03	---	0.03	.16
7500	---	---	.10	.18	---	.03	---	.10	---	.03	---	0.03	.17
7750	---	---	.10	.19	---	.04	---	.10	---	.03	---	0.03	.18
8000	---	---	.11	.20	---	.04	---	.11	---	.04	---	0.03	.19
8250	---	---	.11	.21	---	.04	---	.11	---	.04	---	0.03	.20
8500	---	---	.12	.22	---	.04	---	.12	---	.04	---	0.03	.21
8750	---	---	.12	.23	---	.05	---	.12	---	.04	---	0.03	.22
9000	---	---	.13	.24	---	.05	---	.13	---	.04	---	0.03	.24
9250	---	---	.14	.25	---	.05	---	.14	---	.04	---	0.03	.25
9500	---	---	.14	.26	---	.05	---	.14	---	.05	---	0.04	.26
9750	---	---	.15	.27	---	.06	---	.15	---	.05	---	0.04	.27
10,000	---	---	.15	.28	---	.06	---	.16	---	.06	---	0.04	.29
10,250	---	---	.15	.29	---	.06	---	.16	---	.06	---	0.04	.30
10,500	---	---	.16	.30	---	.07	---	.17	---	.06	---	0.04	.31
10,750	---	---	.16	.31	---	.07	---	.18	---	.06	---	0.04	.33
11,000	---	---	.16	.32	---	.07	---	.18	---	.07	---	0.04	.34

**BLOWER DATA
LGA / LCA / LHA**

CEILING DIFFUSER AIR RESISTANCE						
Unit Size	Air Volume		Total Resistance - inches water gauge (Pa)			
			RTD11 Step-Down Diffuser			FD11 Flush Diffuser
	cfm	L/s	2 Ends Open	1 Side 2 Ends Open	All Ends & Sides Open	
156 & 180 Models	5000	2360	.51 (127)	.44 (109)	.39 (97)	.27 (67)
	5200	2455	.56 (139)	.48 (119)	.42 (1040)	.30 (75)
	5400	2550	.61 (152)	.52 (129)	.45 (112)	.33 (82)
	5600	2645	.66 (164)	.56 (139)	.48 (119)	.36 (90)
	5800	2735	.71 (177)	.59 (147)	.51 (127)	.39 (97)
	6000	2830	.76 (189)	.63 (157)	.55 (137)	.42 (104)
	6200	2925	.80 (199)	.68 (169)	.59 (147)	.46 (114)
	6400	3020	.86 (214)	.72 (179)	.63 (157)	.50 (124)
	6600	3115	.92 (229)	.77 (191)	.67 (167)	.54 (134)
	6800	3210	.99 (246)	.83 (206)	.72 (174)	.58 (144)
	7000	3305	1.03 (256)	.87 (216)	.76 (189)	.62 (154)
	7200	3400	1.09 (271)	.92 (229)	.80 (199)	.66 (164)
	7400	3490	1.15 (286)	.97 (241)	.84 (209)	.70 (174)
	7600	3585	1.20 (301)	1.02 (254)	.88 (219)	.74 (184)
210, 240 & 300S Models	6000	2830	.36 (90)	.31 (77)	.27 (67)	.29 (72)
	6500	3065	.42 (104)	.36 (90)	.31 (77)	.34 (85)
	7000	3305	.49 (122)	.41 (102)	.36 (90)	.40 (99)
	7500	3540	.51 (127)	.46 (114)	.41 (102)	.45 (112)
	8000	3775	.59 (147)	.49 (122)	.43 (107)	.50 (124)
	8500	4010	.69 (172)	.58 (144)	.50 (124)	.57 (142)
	9000	4245	.79 (196)	.67 (167)	.58 (144)	.66 (164)
	9500	4485	.89 (221)	.75 (186)	.65 (162)	.74 (184)
	10,000	4720	1.00 (249)	.84 (209)	.73 (182)	.81 (201)
	10,500	4955	1.10 (273)	.92 (229)	.80 (199)	.89 (221)
11,000	5190	1.21 (301)	1.01 (251)	.88 (219)	.96 (239)	

POWER EXHAUST FANS PERFORMANCE			
Return Air System Static Pressure		Air Volume Exhausted	
in. w.g.	Pa	cfm	L/s
0	0	8630	4070
0.05	12	8210	3875
0.10	25	7725	3645
0.15	37	7110	3355
0.20	50	6470	3055
0.25	62	5790	2730
0.30	75	5060	2390
0.35	87	4300	2030
0.40	100	3510	1655
0.45	112	2690	1270
0.50	125	1840	870

CEILING DIFFUSER AIR THROW DATA						
Model No.	Air Volume		*Effective Throw Range			
			RTD11 Step-Down		FD11 Flush	
	cfm	L/s	ft.	m	ft.	m
156 Models 180 Models	5250	2475	42-54	13-16	44-49	13-15
	6000	2830	45 - 55	14 - 17	48 - 55	15 - 17
	6750	3190	47 - 56	14 - 17	50 - 58	15 - 18
	7500	3540	49 - 58	15 - 18	55 - 66	17 - 20
210 Models 240 Models 300S Models	8000	3775	39 - 44	12 - 13	53 - 62	16 - 19
	9000	4245	47 - 56	14 - 17	55 - 64	17 - 20
	10,000	4720	49 - 58	15 - 18	57 - 67	17 - 20
	11,000	5190	54 - 65	17 - 21	59 - 70	18 - 22

*Throw is the horizontal or vertical distance an airstream travels on leaving the outlet or diffuser before the maximum velocity is reduced to 50 ft. (15 m) per minute. Four sides open.

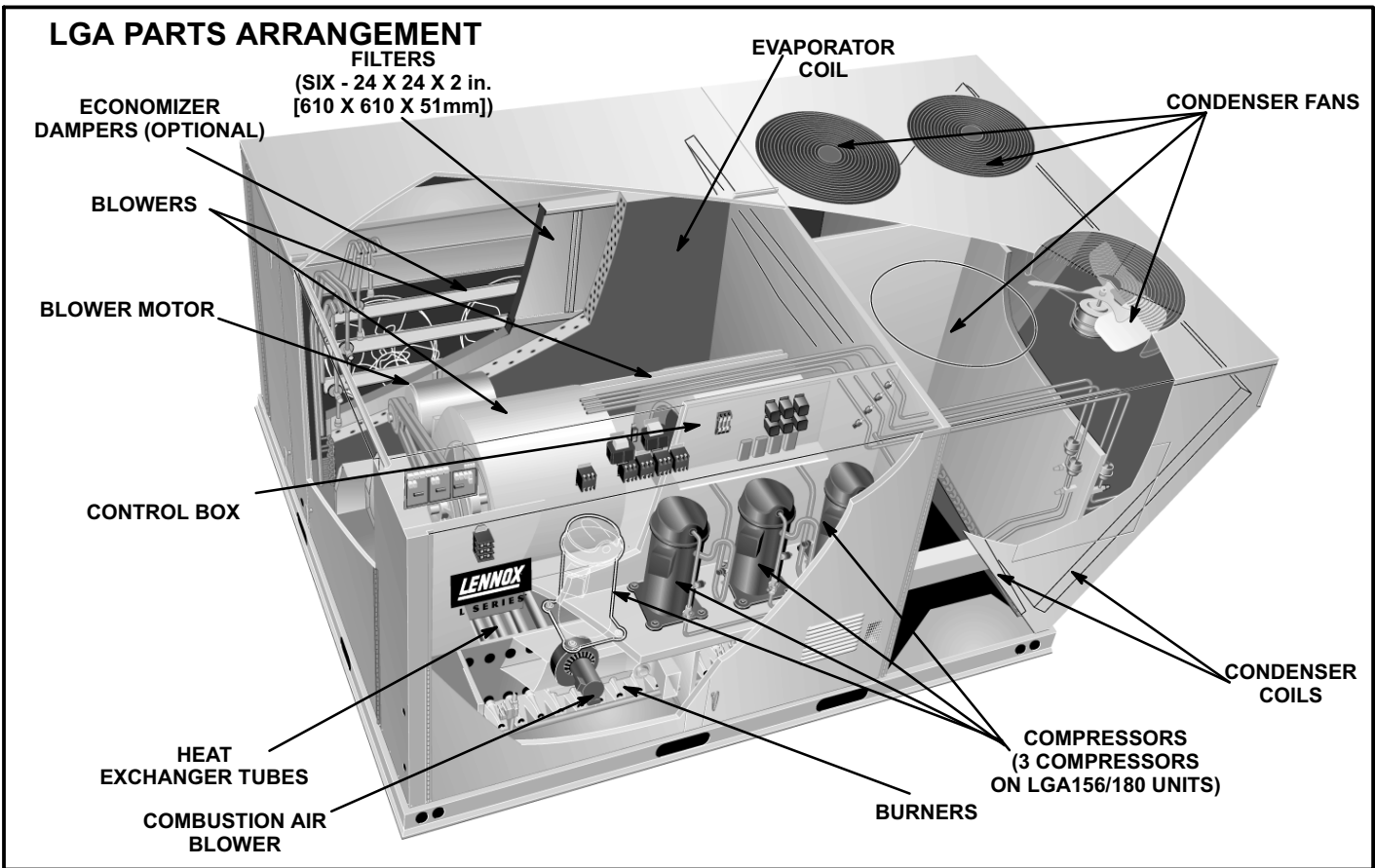

FIGURE 1

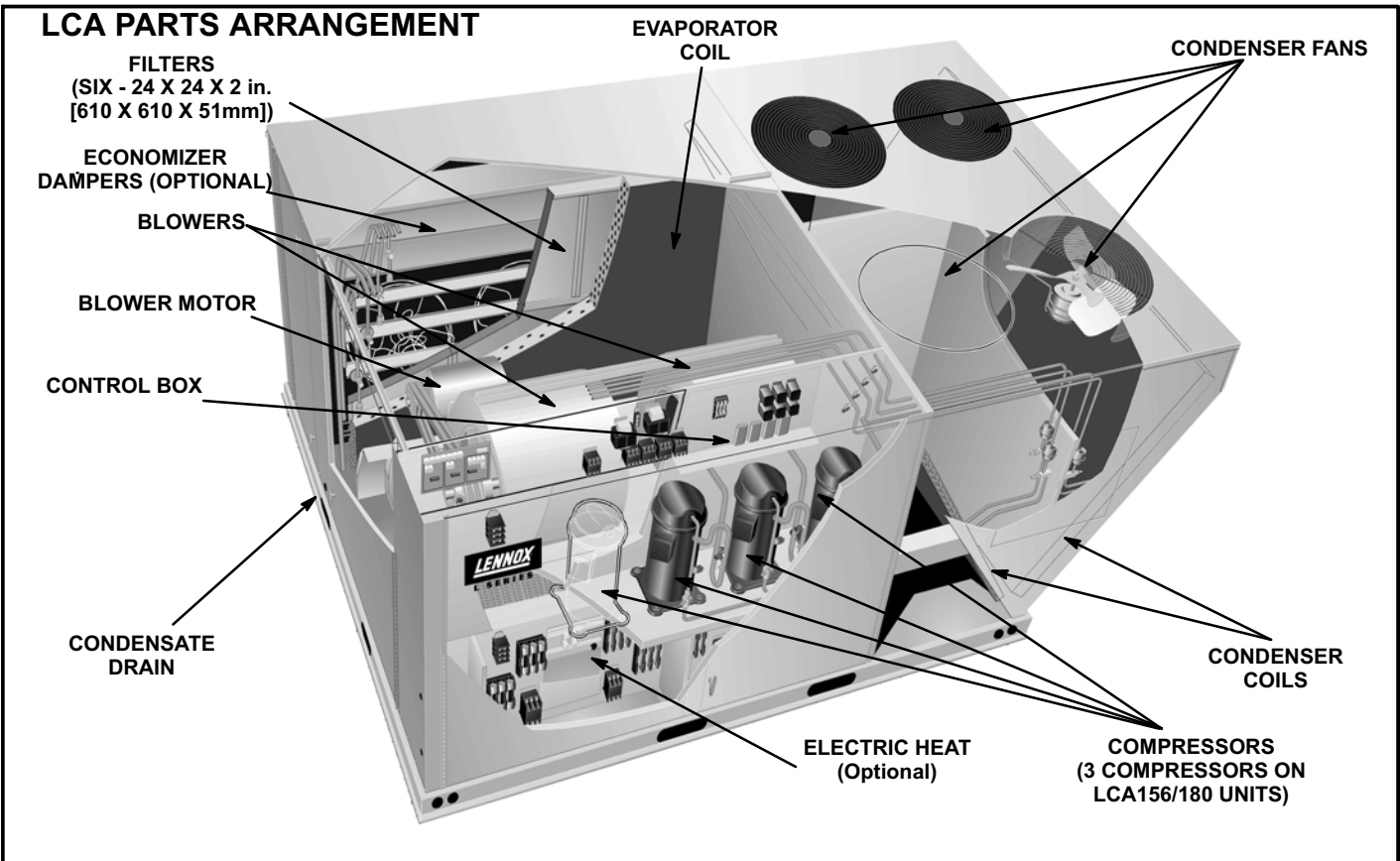

FIGURE 2

LHA180 / 240 PARTS ARRANGEMENT

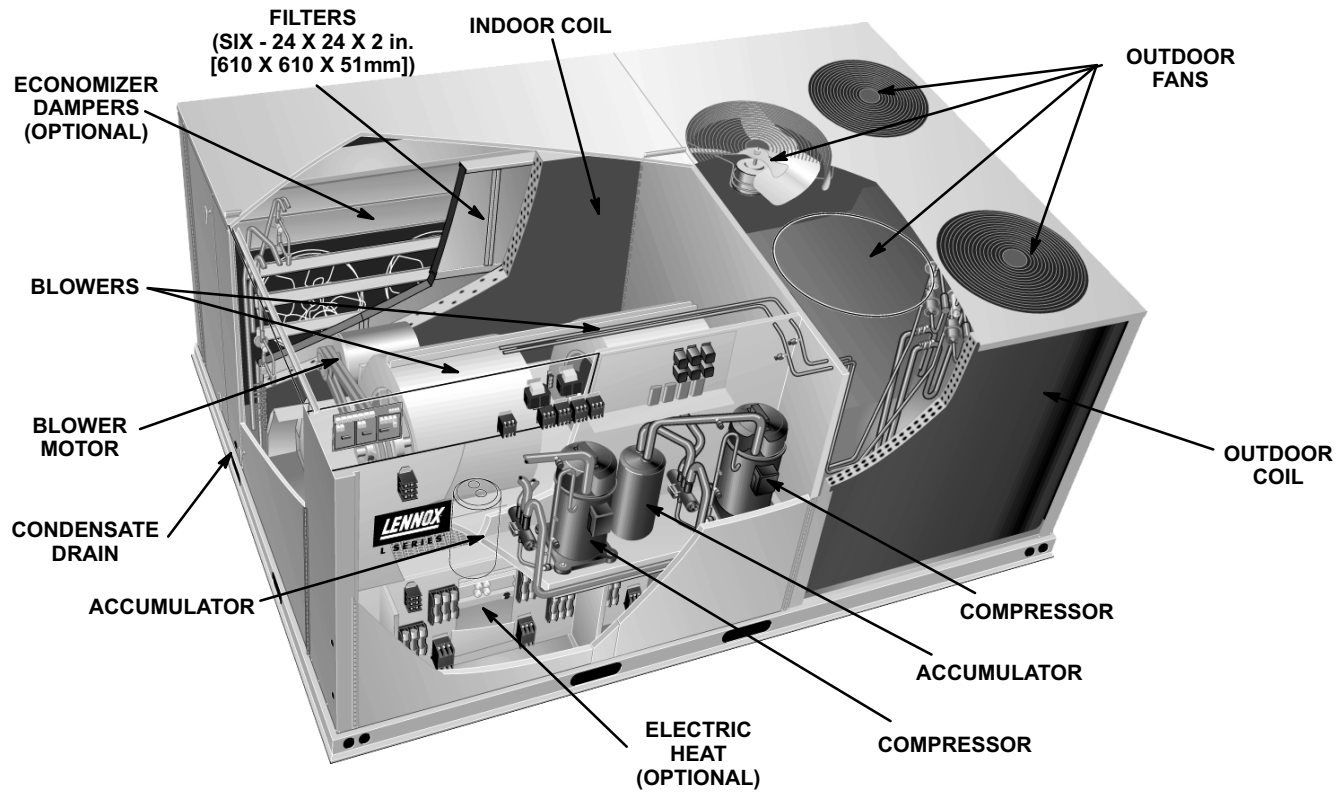
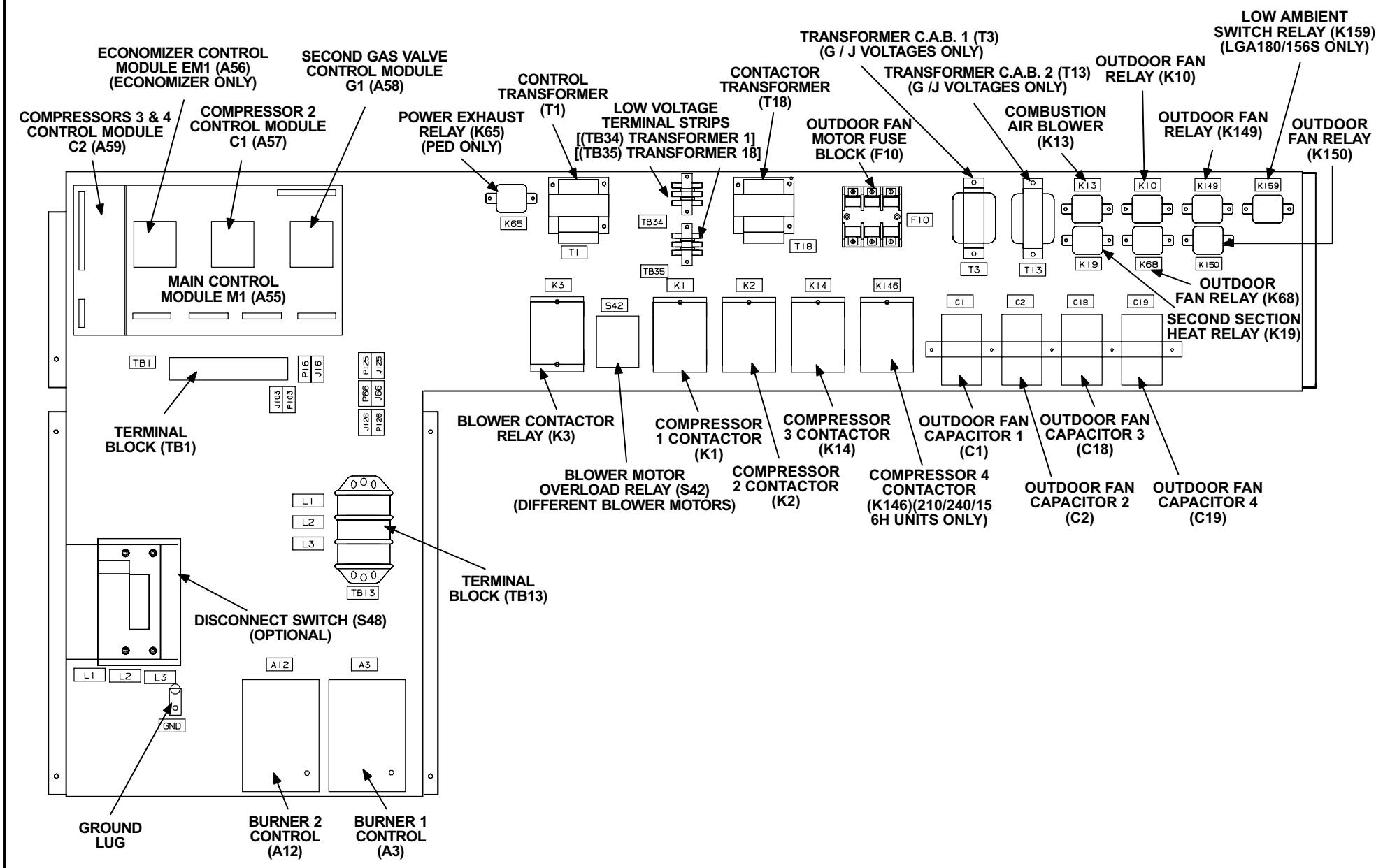

FIGURE 3

LGA CONTROL BOX PARTS ARRANGEMENT



Page 32

FIGURE 4

LCA CONTROL BOX PARTS ARRANGEMENT

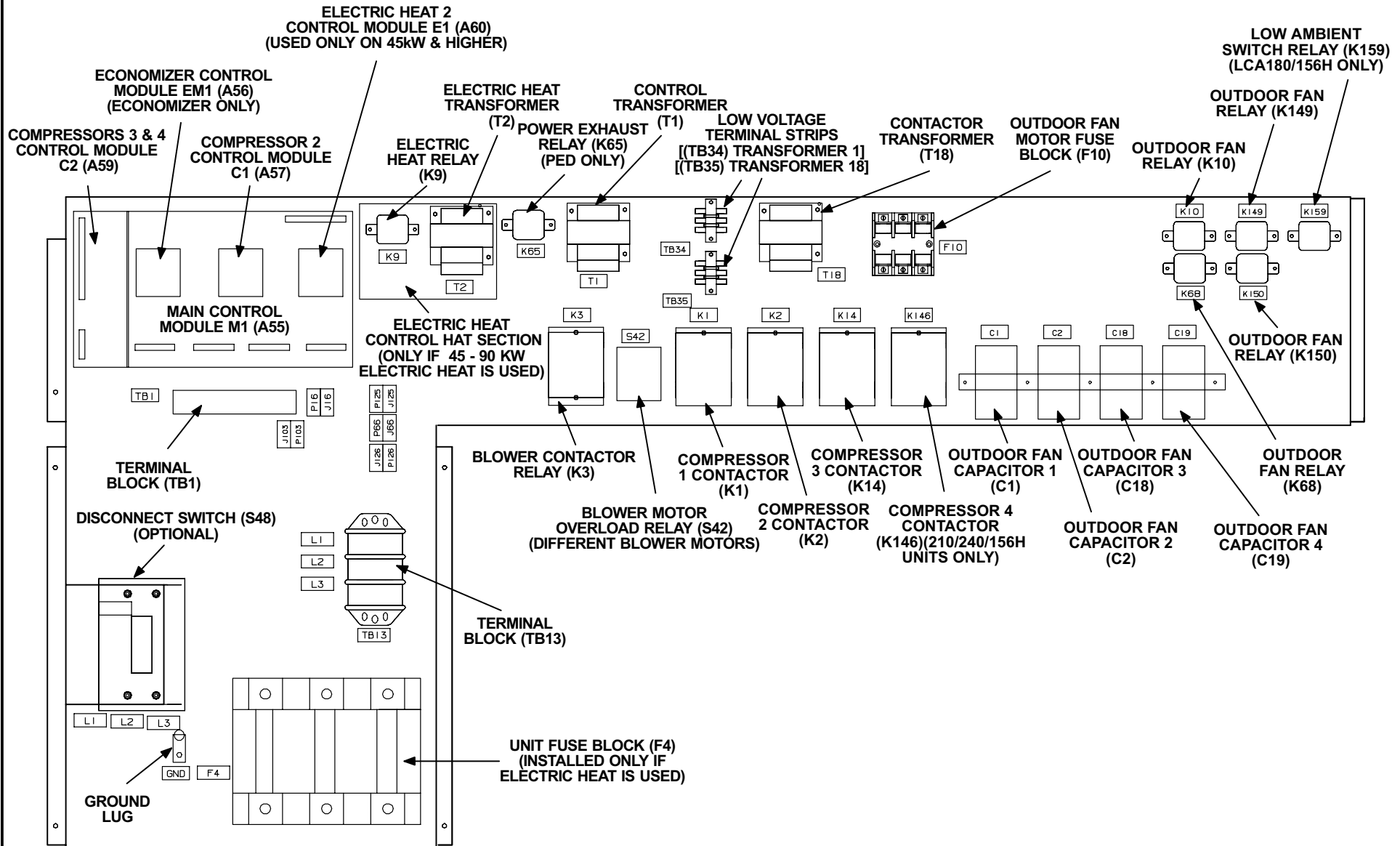

FIGURE 5

LHA 15 and 20 TON (53 and 70 KW) CONTROL BOX PARTS ARRANGEMENT

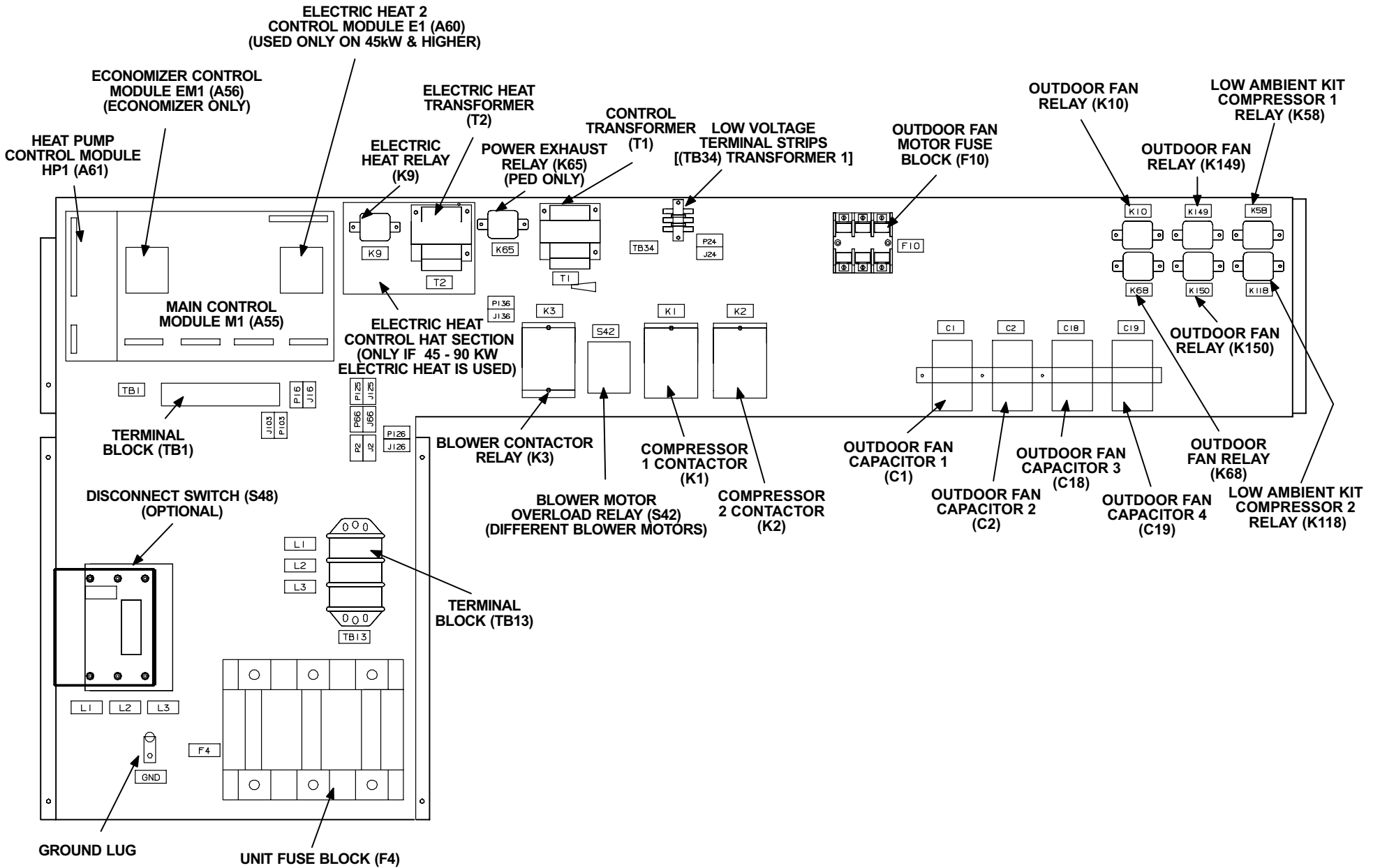

FIGURE 6

I-UNIT COMPONENTS

LGA / LCA / LHA13, 15, 17.5, 20 and 25 ton (46, 53, 62, 70, and 88 kW) units are configured to order units (CTO). The LGA and LCA unit components are shown in figures 1 and 2. For LHA 15 and 20 ton (52.8 and 70.3 kW) series unit components see figure 3. All units come standard with hinged unit panels. The unit panels may be held open with the door rod located inside the unit. All L1, L2, and L3 wiring is color coded; L1 is red, L2 is yellow, and L3 is blue.

A-Control Box Components

ELECTROSTATIC DISCHARGE (ESD) Precautions and Procedures

⚠ CAUTION

Electrostatic discharge can affect electronic components. Take precautions during furnace installation and service to protect the furnace's electronic controls. Precautions will help to avoid control exposure to electrostatic discharge by putting the furnace, the control and the technician at the same electrostatic potential. Neutralize electrostatic charge by touching hand and all tools on an unpainted unit surface, such as the gas valve or blower deck, before performing any service procedure.

LGA control box components are shown in figure 4, while LCA control box components are shown in figure 5. LHA control box components are shown in figure 6. The control box is located in the upper left portion of the compressor compartment.

1-Disconnect Switch S48 (Optional all units)

All LGA/LCA/LHA units may be equipped with an optional disconnect switch S48. Other factory or field installed optional circuit breakers may be used, such as CB10. S48 and CB10 are toggle switches, which can be used by the service technician to disconnect power to the unit.

2-Control Transformer T1 (all units)

All LGA/LCA/LHA series units use a single line voltage to 24VAC transformer mounted in the control box. Transformer supplies power to control circuits in the unit. The transformer is rated at 70VA and is protected by a 3.5 amp circuit breaker (CB8). The 208/230 (Y) volt-

age transformers use two primary voltage taps as shown in figure 7, while 460 (G) and 575 (J) voltage transformers use a single primary voltage tap.

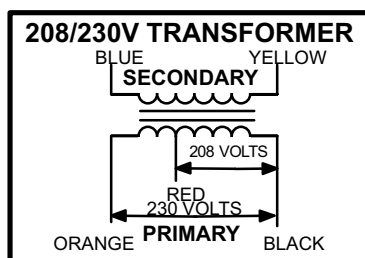

FIGURE 7

3-Contactor Transformer T18 (LGA / LCA units)

T18 is a single line voltage to 24VAC transformer used in all LGA/LCA series units. Transformer T18 is protected by a 3.5 amp circuit breaker (CB18). T18 is identical to transformer T1. The transformer supplies 24VAC power to the contactors.

4-C. A. B. Transformers T3 & T13 (LGA 460V & 575V units)

All LGA 460 (G) and 575 (J) voltage units use two auto voltage to 230VAC transformers mounted in the control box. The transformers have an output rating of 0.5A. T3 transformer supplies 230 VAC power to combustion air blower motor (B6), while T13 transformer supplies power to combustion air blower motor (B15).

5-Terminal Strips TB1, TB13, TB34 (all units), and TB35 (LGA / LCA units)

TB1 terminal strip distributes 24V power and common from the thermostat to the control box components. TB13 terminal strip distributes line voltage power to the line voltage items in the unit. TB34 terminal strip distributes 24V power from T1 to the control box components. TB35 terminal strip distributes 24V power from T18 to the contactors in the control box.

6-Outdoor Fan Motor Fuse Block & Fuses F10 (all units)

Three line voltage fuses F10 provide overcurrent protection to all condenser fans (and optional power exhaust fans) in all LGA / LCA and LHA units. The fuses are rated at 30A in 208/230V units and 15A in all others.

7-Unit Fuse Block & Fuses F4 (LHA & LCA units)

Three line voltage fuses F4 provide short circuit and ground fault protection to all cooling components in the LHA and LCA units. The fuses are rated in accordance with the amperage of the cooling components.

8-Outdoor Fan Capacitors C1, C2, C18, & C19 (all units)

Fan capacitors C1, C2, C18, C19 are 370V / 10 MFD capacitors used to assist in the start up of condenser fans B4, B5, B21, B22 respectively.

9-Compressor Contactor K1 & K2 (all units), K14 (LGA/LCA units), and K146 (LGA/LCA 210, 240 & 300S units)

All compressor contactors are three-pole-double-break contactors with a 24VAC coil. In all LHA units K1 (energized by A55) and K2 (energized by A61) energize compressors B1 and B2 respectively, in response to thermostat demand. In all LGA/LCA156H/180 units K1 (energized by A55), K2 (energized by A57), and K14 (energized by A59) energize compressors B1, B2, and B13 respectively in response

to first or second stage cooling demands. In all LGA/LCA210/240/300S units K1 (energized by A55), K2 (energized by A57), K14 and K146 (energized by A59) energize compressors B1, B2, B13, and B20 respectively.

10-Blower Contactor K3 (all units)

Blower contactor K3, used in all units, is a three-pole-double-break contactor with a 24VAC coil used to energize the indoor blower motor B3 in response to blower demand. K3 is energized by main control panel (A55).

11-Outdoor Fan Relay K10, K68, K149, & K150 (all units)

Outdoor fan relays K10, K68, K149, and K150, used in all units, are DPDT relays with a 24VAC coil. In all LHA units K10 (energized by A55), K68, K149, and K150 (energized by A61) energize condenser fans B4 (fan 1), B5 (fan 2), B21 (fan 3), and B22 (fan 4) respectively, in response to thermostat demand. In the LGA/LCA units, the outdoor fan relays work the same; however, K10 is energized by A55, K68 is energized by A57, and K149 and K150 are energized by A59.

12-Combustion Air Blower Relay K13 (LGA units - first burner section)

Combustion air blower relay K13, used in all LGA units, is a DPDT relay with a 24VAC coil. K13 is energized by the main control module A55 after a first stage heating demand from the thermostat. K13 remains energized throughout the heating demand. When energized, K13 N.O. contacts close to energize combustion air blower and begin a heating sequence. Pressure switch S18, located in the compressor compartment, closes as combustion air static pressure falls to “prove” combustion air blower operation. When S18 closes, the ignition controls and gas valves are energized to begin a heating sequence.

13-Combustion Air Blower Relay K19 (LGA units - second burner section)

Combustion air blower relay K19, used in all LGA units, is a DPDT relay with a 24 VAC coil. K19 is energized by the gas valve control module A58 after a first stage heating demand from the thermostat. K19 remains energized throughout the first stage heating demand. When energized, K19 N.O. contacts close to energize the second heat section combustion air blower and begin second section heating sequence. Pressure switch S45, located in the compressor compartment, closes as combustion air static pressure falls to “prove” combustion air blower operation. When S45 closes, the second section of the ignition control and gas valve are energized to begin the second section heating sequence.

14-Low Ambient Switch Relay K159 (LGA/LCA180 units)

Low ambient switch relay K159, used in all LGA/LCA156H/180 units, is a DPDT relay with a 24VAC coil. When one of the N.O. low pressure low ambient switches S11, S84, or S85 close (due to a pressure rise), K159 is energized. When K159-1 closes, A55 energizes K10 which in turn energizes outdoor fan motor B4. When K159-2 closes, A59 energizes K149 which in turn energizes outdoor fan motor B21. When the pressure lowers due to the outdoor fan motors cycling on, the pressure switch(es) will open and K159 will be de-energized.

15-Low Ambient Bypass Fan (Kit) Relays K58 & K118 (LHA units)

Low ambient bypass relays K58 and K118, used in all LHA units, are N.C. DPDT relays with a 24VAC coil. K58 is wired in parallel with the first compressor reversing valve (L1) and is energized by A55. K118 is wired in parallel with the second compressor reversing valve (L2) and is energized by A61. When L1 is energized in the cooling cycle, K58 is also energized, opening K58-1. When L2 is energized in the cooling cycle, K118 is also energized, opening K118-1. Therefore, K58-1 and K118-1 are always closed during heating demand bypassing S11 and S84. This allows all fans to operate during heating demand and to cycle during cooling demand.

16-Burner Controls A3 & A12 (LGA units)

All LGA units have two burner controls. A3 controls gas heat section one, while A12 controls gas heat section two. The first gas heat section and the second gas heat section burner controls are identical. Both burner controls are factory set and are not adjustable. The control makes three attempts at ignition and then locks out the system if ignition is not obtained after the third trial. Reset after lockout requires only breaking and remaking thermostat demand. The control shuts off gas flow immediately in the event of a gas or power failure. Upon restoration of gas and power, the control will restart the ignition sequence and continue until flame is established or system locks out. For a more detailed description see the Gas Heat Components section.

17-Power Exhaust Relay K65 (PED units)

Power exhaust relay K65 is a N.O. DPDT relay with a 24VAC coil. K65 is used in all LGA/LCA/LHA units equipped with the optional power exhaust dampers. K65 is energized by the economizer control panel (A56), after the economizer dampers reach 50% open (adjustable in ECTO). When K65 closes, the exhaust fans B10 and B11 are energized.

18-Blower Motor Overload Relay S42 (units with high efficiency motors & standard efficiency motors of 7.5 HP and above)

The blower motor overload relay is used in all L series units equipped with high efficiency motors, as well as units with standard efficiency motors 7.5 HP and higher. The relay (S42) is connected in line with the blower motor to monitor the current flow to the motor. When the relay senses an overload condition, a set of normally closed contacts open to de-energize pin #9 in plug 110 of the A55 main control module. A55 de-energizes all outputs. Early model units have been equipped with a control manufactured by Telemecanique which is detailed in figure 8. Units built after November 21, 1997, are equipped with a relay manufactured by Siemens which is detailed in figure 9. 7.5 HP motors used in units built in late 1998, will have an internal overload relay.

ELECTRIC HEAT CONTROL HAT SECTION (45 - 90 kW electric heat only)

19-Electric Heat Relay K9

All LCA/LHA series units with 45 - 90 kW electric heat use an electric heat relay K9. K9 is a N.O. SPST pilot relay intended to electrically isolate the unit's 24V circuit from the electric heat 24V circuit. K9 is energized by the main control board A55. K9-1 closes, enabling T2 to energize the electric heat control panel A60 and contactors K17 and K18.

20-Electric Heat Transformer T2

All LCA/LHA series units with 45 - 90 kW electric heat use a single line voltage to 24VAC transformer mounted in the electric heat control hat section in the control box. The transformer supplies power to all electric heat controls (contactors and coils). The transformer is rated at 70VA and is protected by a 3.5 amp circuit breaker CB13. The 208/230 (Y) voltage transformers use two primary voltage taps as shown in figure 7. Transformer T2 is identical to T1.

INTEGRATED MODULAR CONTROL BOARDS

The Integrated Modular Control (IMC) is a series of control boards which integrates most control functions required for the LGA/LCA/LHA units. The control boards are located in the upper left hand corner of the control box. The control includes complete unit diagnostics with permanent code storage, field programmable control parameters and control options, on-site testing, and serial communications. Seven different printed circuit boards (see figure 10) make-up the modular configurations for the LGA/LCA/LHA units. See table 1 for a list of control panels used for each unit. For further information refer to Integrated Modular Control Guide sent with each unit.

TABLE 1

UNIT	CONTROL PANELS						
	A55	A57	A59	A58	A60	A61	A56
LGA	X	X	X	X			OPT
LCA	X	X	X		X		OPT
LHA	X				X	X	OPT

21-Main Control Module A55 (all units)

The main control module A55 is the heart of the system. It controls one compressor, one two-stage gas valve, one bank of electric heat, one outdoor fan, and one blower. A55 includes the thermostat inputs, serial communications ports, diagnostic code display, control pushbutton, system configuration dip switches, and four expansion ports. A diagnostic code list is located on the back side of the left access panel.

22-Compressor 2 Control Module A57 (LGA & LCA units)

The compressor 2 control module A57 controls one additional compressor stage for the LGA/LCA units. A57 includes all inputs and outputs required for compressor and fan control, compressor stages diagnostics, and low ambient control.

23-Compressor 3 & 4 Control Module A59 (LGA & LCA units)

The compressor 3 & 4 control module A59 controls two additional compressor stage for the LGA/LCA units. A59 includes all inputs and outputs required for compressor and fan control, compressor stage diagnostics, and low ambient control.

24-Gas Valve Control Module A58 (LGA units)

The gas valve control module A58 controls an additional burner with a two-stage gas valve. A58 includes all inputs and outputs required for control and diagnostics of one two-stage gas valve burner.

25-Electric Heat Control Module A60 (LCA & LHA units if 45 - 90 kW electric heat is used)

The electric heat control module A60 is used to control a second electric heat bank. A60 is used on the LHA and LCA units.

26-Heat Pump Control Module A61 (LHA units)

The heat pump control module A61 is used to control the second compressor stage on the LHA units. Like the A57 and A59 boards, the A61 board includes all inputs and outputs required for the compressor and fan control, compressor stage diagnostics and low ambient control.

27-Economizer Control Module A56 (Economizer only)

The economizer control module A56 controls the economizer. A56 has four different cooling modes, sensible temperature, outdoor enthalpy, differential enthalpy, and global control.

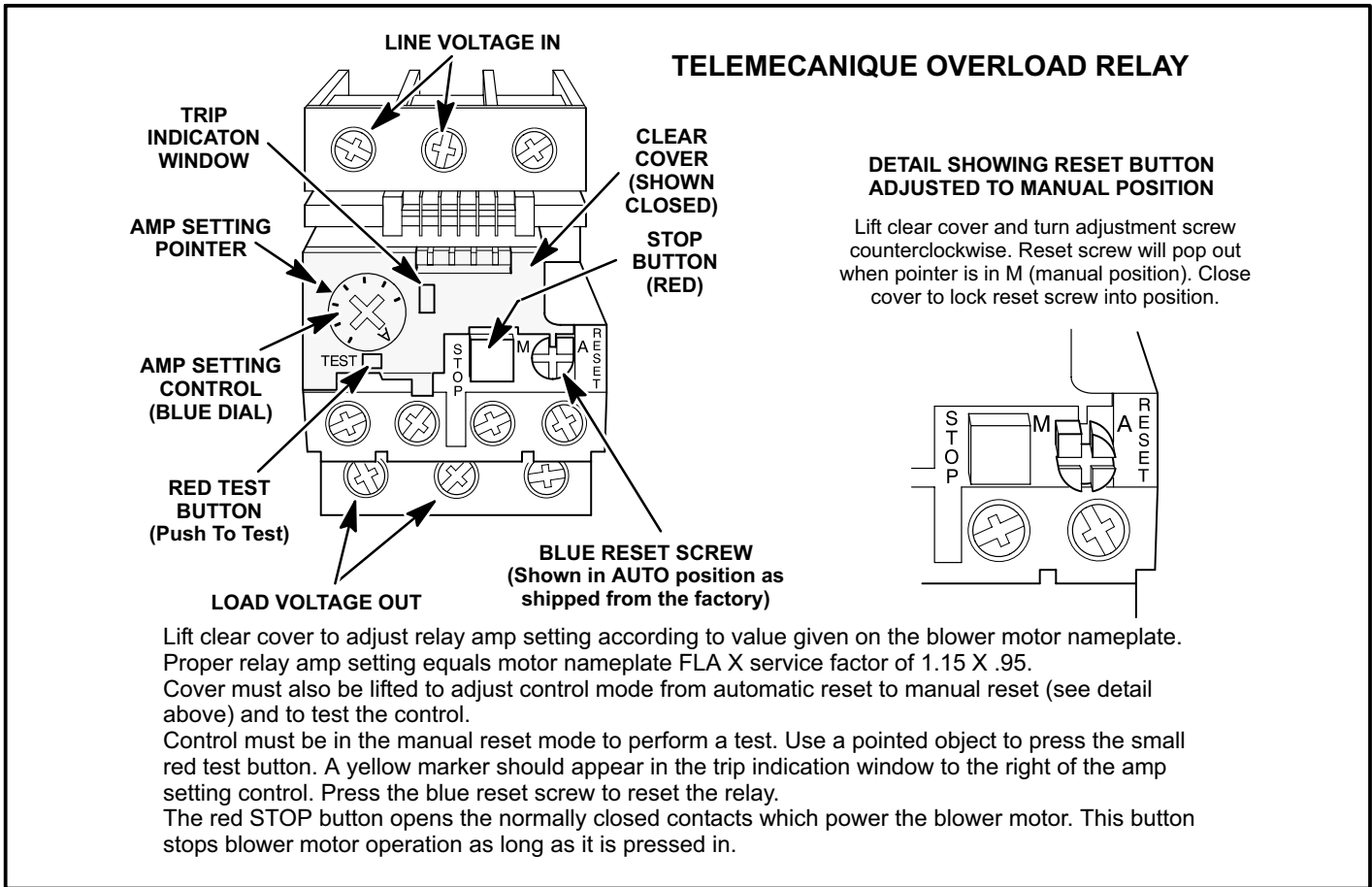

FIGURE 8

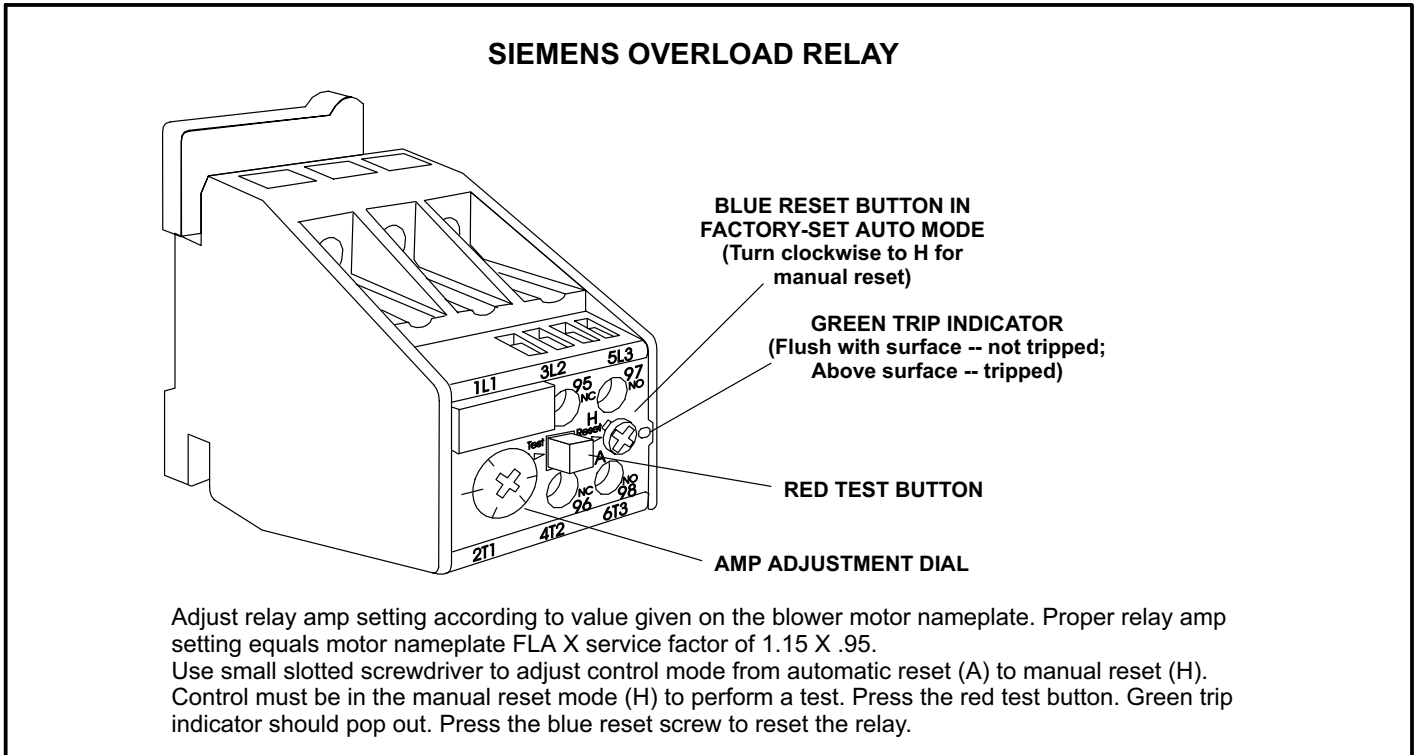
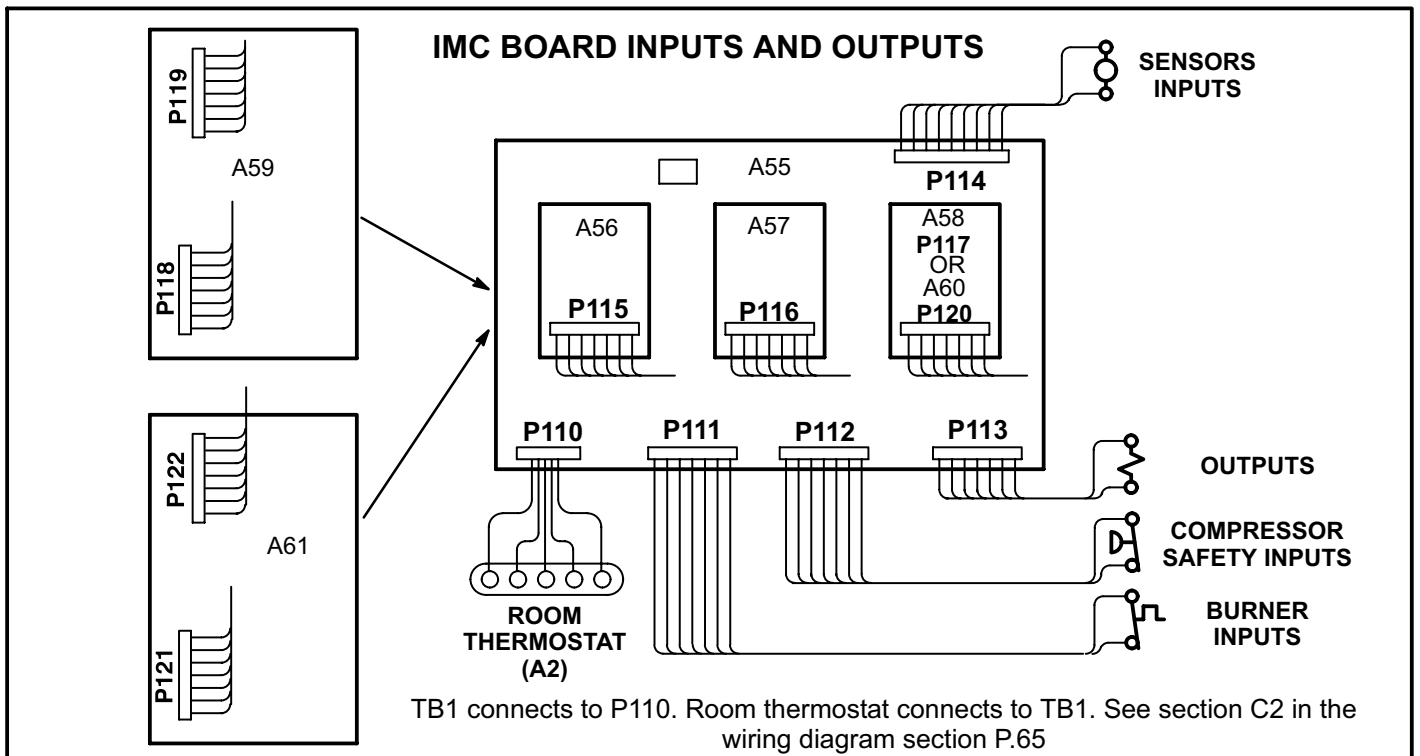

FIGURE 9



IMC AND ADD-ON BOARD LOCATION AND OPERATION

A59 (LCA / LGA): Compressors 3 and 4 2 Outdoor Fans or A61 (LHA): Heat Pump Compressor 2 3 Outdoor fans 1 Reversing valve	1 Blower 1 Compressor 1 Outdoor fan <div style="border: 1px dashed black; padding: 5px; display: inline-block;"> A56: Optional Economizer and/or Power Exhaust Fan </div> <div style="border: 1px dashed black; padding: 5px; display: inline-block;"> A57 (LCA / LGA): Second compressor 1 Outdoor fan </div>	A55: 1 Gas valve 1 Reversing valve 1 Electric heat section <div style="border: 1px dashed black; padding: 5px; display: inline-block;"> A58 Second Gas Valve or A60 Second Electric Heat Section or A61 (RH1) Humiditrol® Control </div>
---	---	---

FIGURE 10

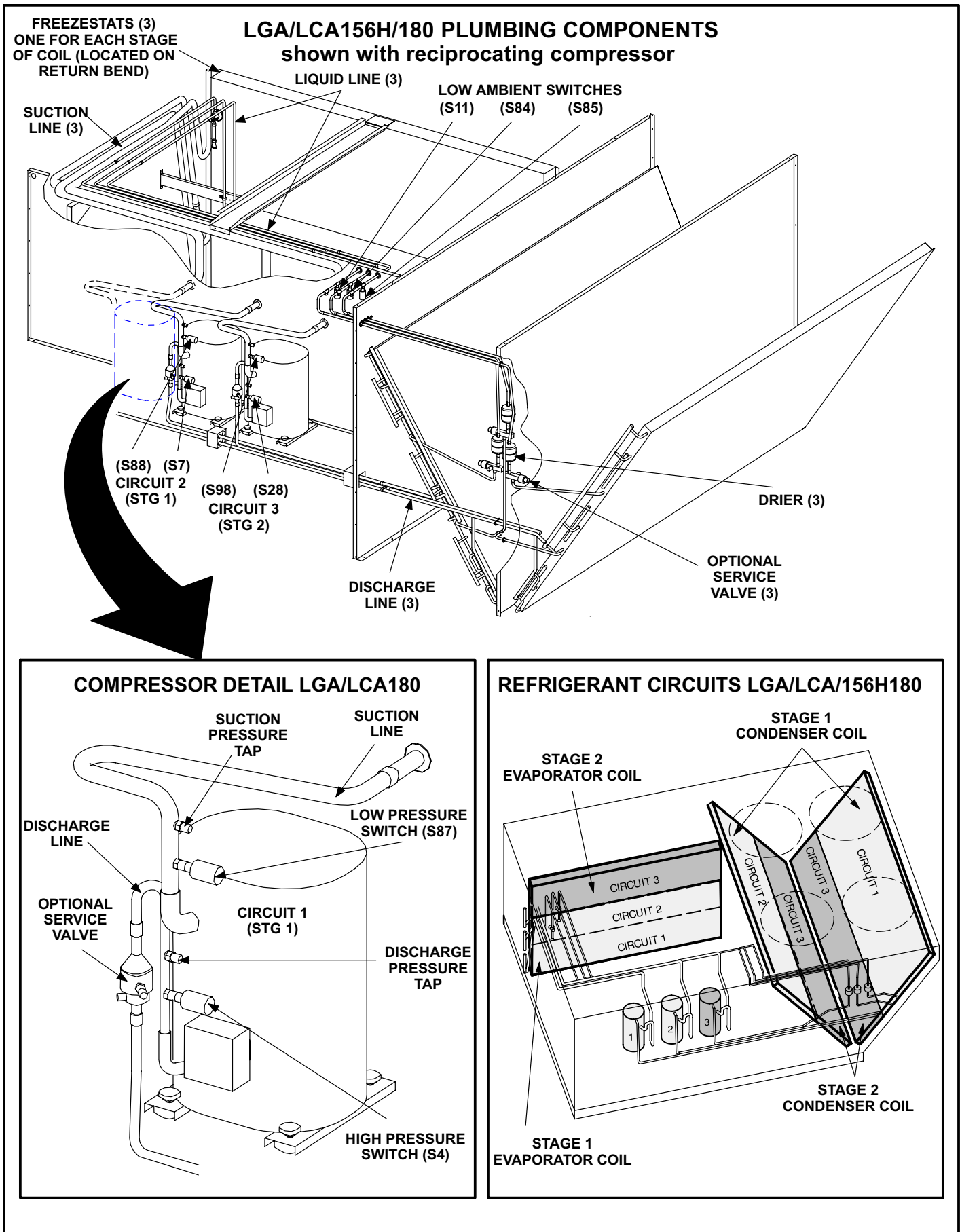
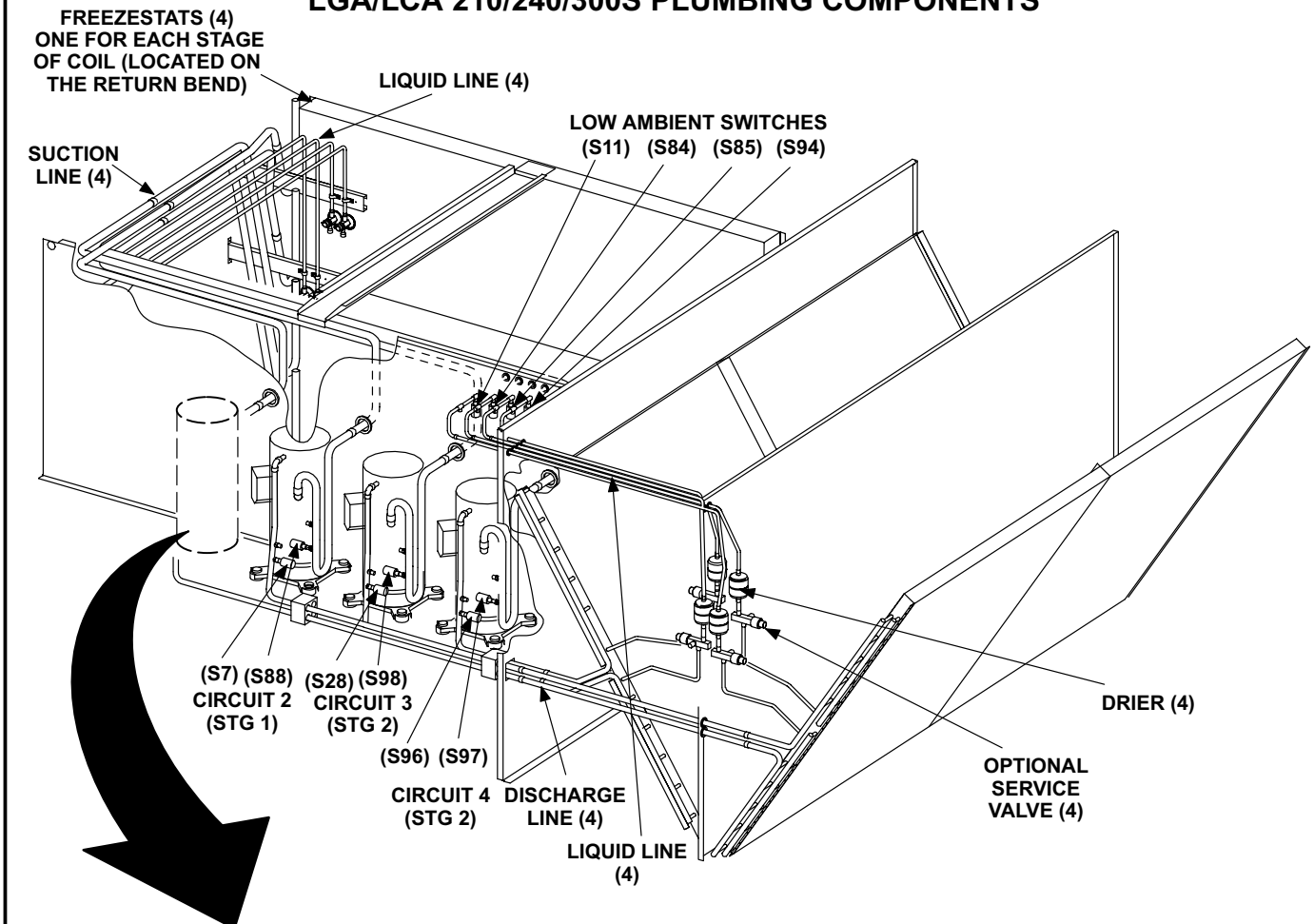
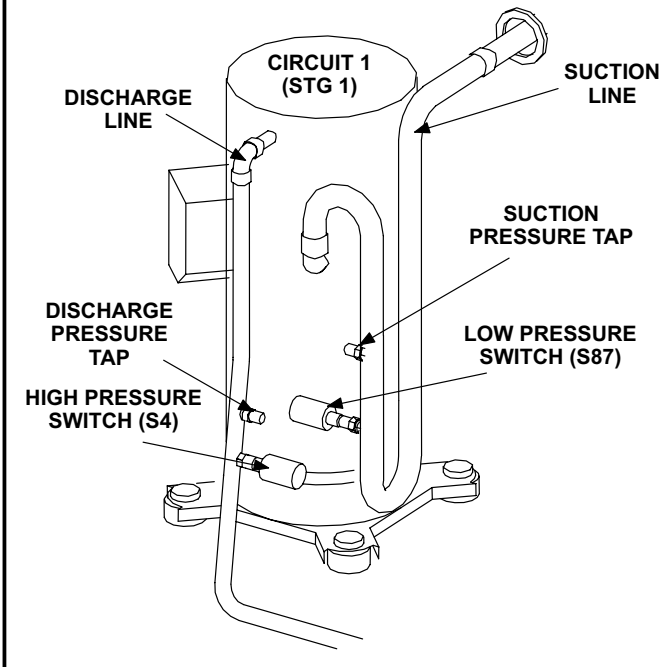

FIGURE 11

LGA/LCA 210/240/300S PLUMBING COMPONENTS



COMPRESSOR DETAIL LGA/LCA 210/240/300S



REFRIGERANT CIRCUITS LGA/LCA 210/240/300S

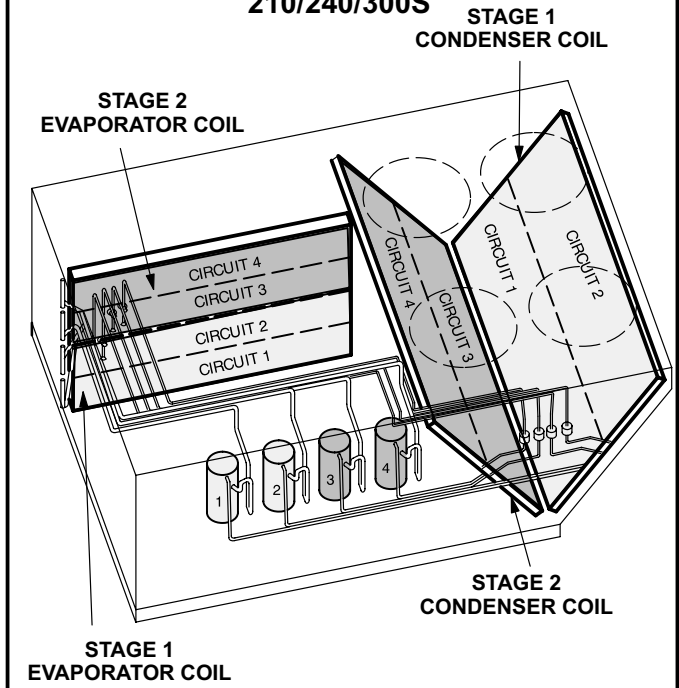

FIGURE 12

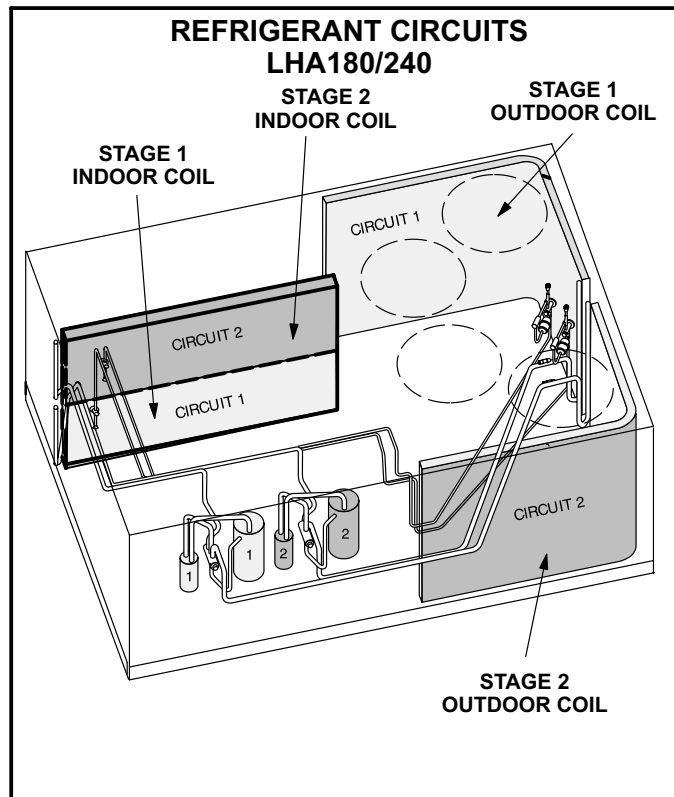
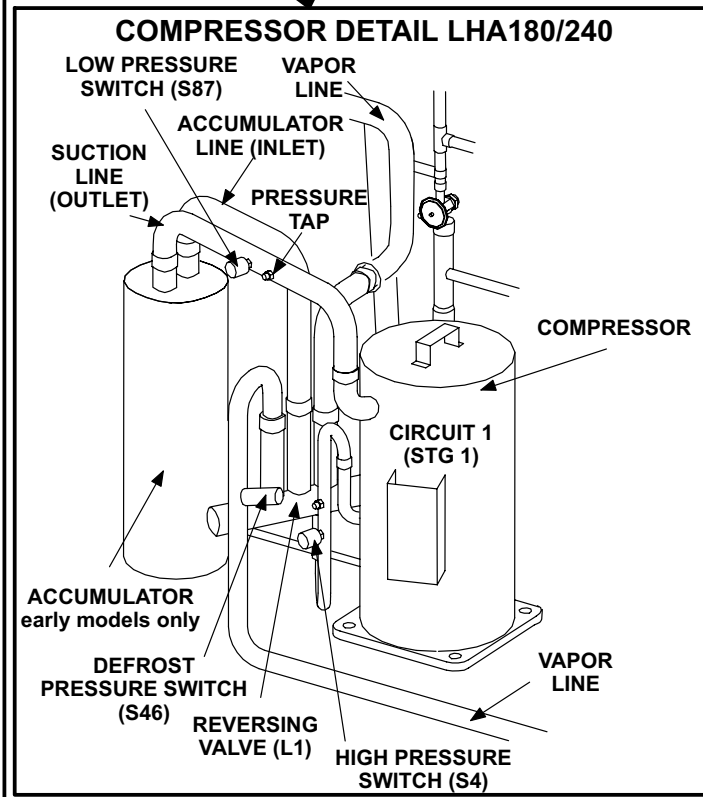
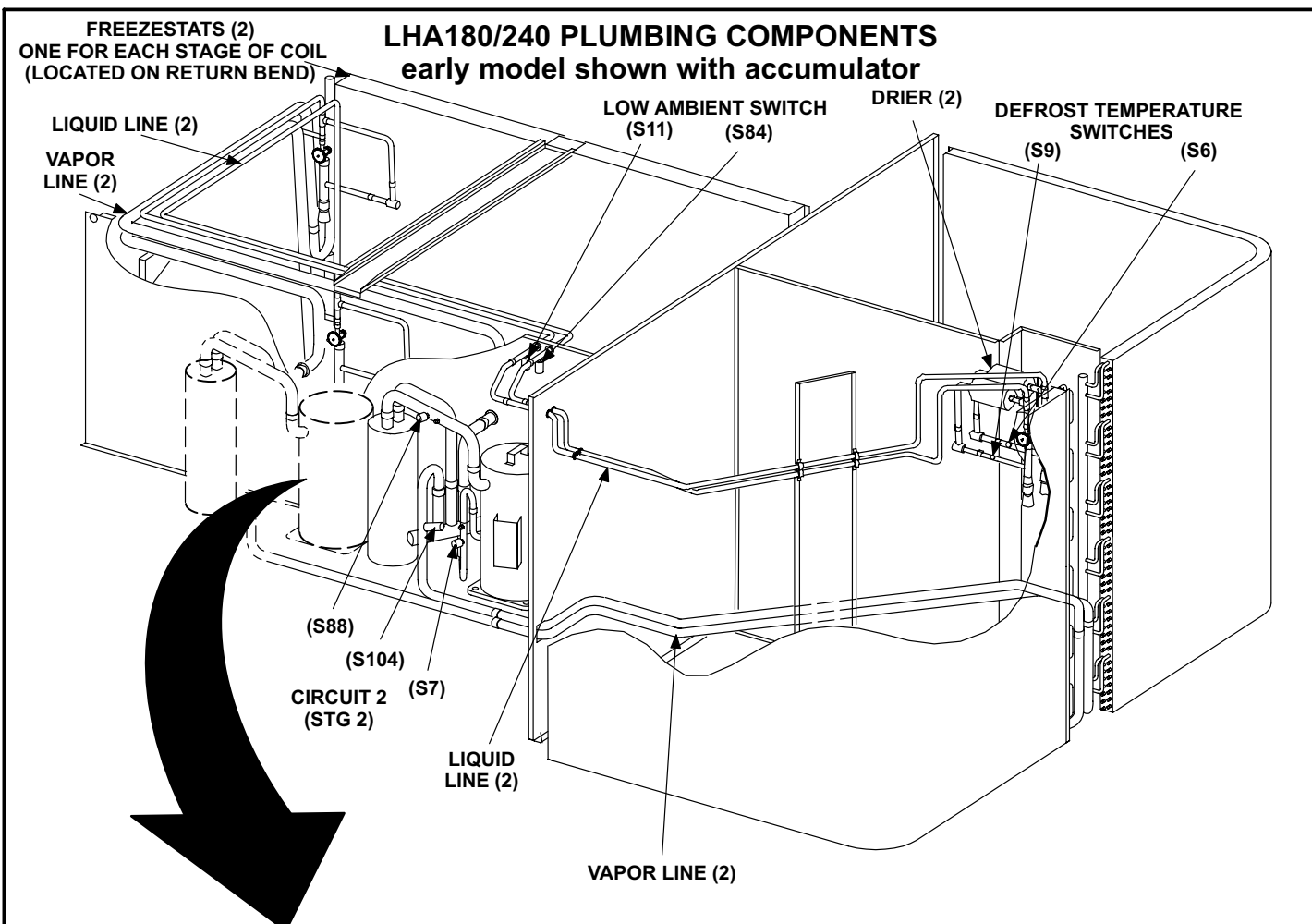

FIGURE 13

B-Cooling Components

LGA/LCA/LHA units use independent cooling circuits consisting of separate compressors, condenser coils and evaporator coils. See figures 11, 12, and 13. Four draw-through type condenser fans are used in all units. All units are equipped with belt-drive blowers which draw air across the evaporator during unit operation.

Cooling may be supplemented by a factory- or field-installed economizer. The evaporators are slab type and are stacked. Each evaporator uses a thermostatic expansion valve as the primary expansion device. Each evaporator is also equipped with enhanced fins and rifled tubing. In all units each compressor is protected by a crankcase heater, high pressure switch and low pressure switch. Additional protection is provided by low ambient switches and freeze-stats (on each evaporator).

1-Compressors B1 and B2 (all units)

B13 (all LGA/LCA/156H 180/210/240 units)

B20 (all LGA/LCA 210/240/300S units)

Early model LGA/LCA standard efficiency and early model LHA high efficiency units use reciprocating type compressors. All LGA and LCA high efficiency units, late model LGA/LCA standard efficiency and late model LHA high efficiency units use scroll compressors. All LGA/LCA 13 ton (46 kW) units use three four ton (14.1 kW) compressors; 15 ton (52.8 kW) units use three five-ton (10.6 kW) compressors; 17.5 ton (61.5 kW) units use four four-ton (14.1 kW) compressors; 20 ton (70.3 kW) units use four five-ton (17.6 kW) compressors and 25 ton (88 kW) units use four six ton (21 kW) compressors. All LHA 15 ton (52.8 kW) units use two 7.5-ton (26.4 kW) compressors and 20-ton (70.3 kW) units use two 10-ton (35.2 kW) compressors. All units are equipped with independent cooling circuits. Likewise, compressor capacity may vary from stage to stage. In all cases, the capacity of each compressor is added to reach the total capacity of the unit.

WARNING

Electrical shock hazard. Compressor must be grounded. Do not operate without protective cover over terminals. Disconnect power before removing protective cover. Discharge capacitors before servicing unit. Failure to follow these precautions could cause electrical shock resulting in injury or death.

Each compressor is energized by a corresponding compressor contactor.

NOTE-Refer to the wiring diagram section for specific unit operation.

2-Crankcase Heaters HR1 and HR2 (all units)

HR5 (LGA/LCA 156H/180/210/240/300S)

HR11 (LGA/LCA 210/240/300S)

Early model LGA/LCA standard efficiency units use insertion type heaters. All other modes use belly-band type crankcase heaters. HR1 is installed around compressor B1, heater HR2 compressor B2, HR5 compressor B13, and HR11 compressor B20. Crankcase heater wattage varies by compressor size.

IMPORTANT

Pressure switch settings on R410A charged units are significantly higher than units charged with R22.

3-High Pressure Switches

S4 and S7 (all units)

S28 (LGA/LCA 156H/180/210/240/300S)

S96 (LGA/LCA 210/240/300S)

The high pressure switches is an auto-reset SPST N.C. switch which opens on a pressure rise. All LGA/LCA/LCC/LHA units are equipped with this switch. The switch is located in the compressor discharge line and is wired in series with the compressor contactor coil.

S4 (first circuit), S7 (second circuit), S28 (third circuit), and S96 (fourth circuit) are wired in series with the respective compressor contactor coils.

Units charged with R22

When discharge pressure rises to 450 ± 10 psig (3103 ± 69 kPa) (indicating a problem in the system) the switch opens and the compressor is de-energized (the economizer can continue to operate). When discharge pressure drops to 300 ± 20 psig (2068 ± 138 kPa) the pressure switch will close.

Units charged with R410A

Units charged with R410A refrigerant will have higher pressure switch settings. When discharge pressure rises to 640 ± 10 psig (4413 ± 69 kPa) (indicating a problem in the system) the switch opens and the compressor is de-energized (the economizer can continue to operate). When discharge pressure drops to 475 ± 20 psig (3275 ± 138 kPa) the pressure switch will close.

Main control A55 has a three-strike counter before locking out. This means the control will allow three high pressure trips per one thermostat demand. The control can be reset by breaking and remaking the thermostat demand or manually resetting the control.

4-Low Ambient Switches S11 & S84(all units) S85 (LGA/LCA 156H/180/210/240/300S) S94 (LGA/LCA 210/240/300S)

The low ambient switch is an auto-reset SPST N.O. pressure switch which allows for mechanical cooling operation at low outdoor temperatures. All LGA/LCA/LHA units are equipped with this switch. In all models a switch is located in each liquid line prior to the indoor coil section.

In the LGA/LCA156H/180 units S11 (compressor one), S84 (compressor two), and S85 (compressor three) are wired in parallel, wired to the low ambient switch relay K159. In the LGA/LCA 210/240/300S units S11 and S84 are in parallel, wired to outdoor fan relay K10, while S85 and S94 (compressor four) are in parallel, wired to third outdoor fan relay K149. In the LHA180/240 units S11 is wired in series with the first outdoor fan relay K10, while S84 is wired in series with the third outdoor fan relay K149.

Units charged with R22

When liquid pressure rises to 275 ± 10 psig (1896 ± 69 kPa), the switch closes and the condenser fan is energized. When discharge pressure in both refrigerant circuits drop to 150 ± 10 psig (1034 ± 69 kPa), the switch opens and the condenser fan is de-energized. This intermittent fan operation results in higher evaporating temperature allowing the system to operate without icing the evaporator coil and losing capacity.

Units charged R410A

Units charged with R410A refrigerant will have higher pressure switch settings. When liquid pressure rises to 450 ± 10 psig (3102 ± 69 kPa), the switch closes and the condenser fan is energized. When discharge pressure in both refrigerant circuits drop to 240 ± 10 psig (1655 ± 69 kPa), the switch opens and the condenser fan is de-energized. This intermittent fan operation results in higher evaporating temperature allowing the system to operate without icing the evaporator coil and losing capacity.

5-Low Pressure Switches S87 & S88(all units) S98 (all LGA/LCA 156H/180/210/240/300S) S97 (LGA/LCA 210/240/300S)

The low pressure switch is an auto-reset SPST N.O. switch (held N.C. by refrigerant pressure) which opens on a pressure drop. All LGA/LCA/LHA units are equipped with this switch.

S87 (compressor one), S88 (compressor two), S98 (compressor three), and S97 (compressor four) are located in the compressor suction line.

The main control module A55 governs the low pressure switches by shunting the switches during start up until pressure is stabilized. After the shunt period, the control has a three-strike counter, during first thermostat demand, before the compressor is locked out. The control is reset by breaking and remaking the thermostat demand or manually resetting the control.

Units charged with R22

When suction pressure drops to 25 ± 5 psig (172 ± 34 kPa) (indicating low pressure), the switch opens and the compressor is de-energized. The switch automatically resets when pressure in the suction line rises to 55 ± 5 psig (379 ± 34 kPa).

Units charged with R410A

Units charged with R410A refrigerant will have higher pressure switch settings. When suction pressure drops to 40 ± 5 psig (276 ± 34 kPa) (indicating low pressure), the switch opens and the compressor is de-energized. The switch automatically resets when pressure in the suction line rises to 90 ± 5 psig (620 ± 34 kPa)

6-Service Valve (optional on LGA/LCA units)

LGA/LCA units may be equipped with service valves located in the discharge and liquid lines. The service valves are manually operated valves used for service operation (not available for Humiditrol units).

7-Discharge Temperature Switches S5 & S8 LHA180/240 with scroll compressors

The discharge temperature switches are located on the units discharge line and wired in series with S4 and S7 high pressure switches. The switches provide overload protection for scroll compressors used on LHA18/240. The switches opens at 240°F (116°C) and close at 190°F (88°C).

8-Reversing Valves L1 and L2 (all LHA180/240 units)

Two refrigerant reversing valves, each with 24 volt solenoid coils, are used to reverse refrigerant flow during unit operation in all LHA units. The reversing valves are connected in the vapor lines of each refrigerant circuit. Reversing valve L1 is connected in the first refrigerant cycle and L2 is connected in the second refrigerant cycle. The reversing valve coils are energized during cooling demand and during defrost.

The reversing valves in all LHA units are wired independently. Reversing valve L1 is controlled by the main control module A55 in response to first stage cooling demand or by first stage defrost. Reversing valve L2 is controlled by the heat pump control module A61 in response to second stage cooling demand or by second stage defrost.

9-Defrost Components and Operation (all LHA180/240 units)

a-Defrost Pressure Switch S46 and S104

The defrost pressure switches (S46 and S104) are auto-reset SPST N.C. pressure switches which open on a pressure rise. All LHA units are equipped with these switches. The switches are located on the suction line during heating cycle (discharge line during cooling and defrost cycle).

S46 (refrigeration circuit one) is wired to the main control board. S104 (refrigeration circuit two) is wired to the heat pump control board.

When discharge pressure reaches 275 ± 10 psig (1096 ± 69 kPa) (indicating defrost is completed) the switch opens. The switch automatically resets when pressure in the suction line drops to 80 ± 10 psig (552 ± 69 kPa).

b-Defrost Thermostat Switches S6 and S9 (all LHA180/240 units)

Defrost thermostat switches S6 (refrigeration circuit one) and S9 (refrigeration circuit two) are S.P.S.T. N.O. contacts which close on a temperature fall (initiating defrost). The switches are located on each of the expansion valve distributor assemblies at the inlet to the outdoor coil. The switches monitor the outdoor coil suction temperature to determine when defrost is needed. When the outdoor coil suction temperature falls to $35^{\circ}\text{F} \pm 4^{\circ}\text{F}$ ($1.7^{\circ}\text{C} \pm 2.2^{\circ}\text{C}$) the switch closes (initiating defrost after minimum run time of 30, 60, or 90 minutes). When the temperature rises to $60^{\circ}\text{F} \pm 5^{\circ}\text{F}$ ($15.6^{\circ}\text{C} \pm 2.8^{\circ}\text{C}$) the switch opens.

DEFROST OPERATION

Defrost operation of each of the two refrigeration circuits are controlled independently with separate timers, thermostats (S6 and S9) and pressure switches (S46 and S104). During heating operation when outdoor coil temperature drops to $35 \pm 4^{\circ}$, the defrost thermostat S6 or S9 closes initiating defrost.

When defrost begins, the reversing valve (L1 or L2) for the circuit in defrost mode is energized. Supplemental electric heat is then energized.

When L1 energizes, N.C. K58-1 contacts open de-energizing outdoor fan relay K10, followed by outdoor fan B4. When L2 energizes, N.C. K118-1 contacts open de-energizing outdoor fan relay K68, followed by outdoor fan B5.

Defrost of a circuit terminates when the pressure switch for the circuit (S46 or S104) opens or when 15 minutes elapse. Defrost does **not** terminate when thermostats demand ends.

10-Accumulator (early model LHA180/240 units)

Early model LHA units are equipped with an accumulator. The purpose of the accumulator is to trap and evaporate all liquid refrigerant and prevent liquid refrigerant from entering the compressor.

11-Filter Drier (all units)

LGA/LCA/LHA units have a filter drier located in the liquid line of each refrigerant circuit at the exit of each condenser coil (outdoor coil in LHA units). The drier removes contaminants and moisture from the system.

12-Freezestats S49 and S50 (all units)

S53(LGA/LCA 156H/180/210/240/300S)

S95(LGA/LCA 210/240/300S)

Each unit is equipped with a low temperature switch (freezestat) located on the return bend of each evaporator coil. S49 (first circuit), S50 (second circuit), S53 (third circuit), and S95 (fourth circuit) are located on the corresponding evaporator coils.

Each freezestat is wired to the main control module A55. Each freezestat is a SPST N.C. auto-reset switch which opens at $29^{\circ}\text{F} \pm 3^{\circ}\text{F}$ ($-1.7^{\circ}\text{C} \pm 1.7^{\circ}\text{C}$) on a temperature drop and closes at $58^{\circ}\text{F} \pm 4^{\circ}\text{F}$ ($14.4^{\circ}\text{C} \pm 2.2^{\circ}\text{C}$) on a temperature rise. To prevent coil icing, freezestats open during compressor operation to temporarily disable the respective compressor until the coil warms sufficiently to melt any accumulated frost. If the freezestats are tripping frequently due to coil icing, check the unit charge, airflow and filters before allowing unit back in operation. Make sure to eliminate conditions which might promote evaporator ice build-up.

13-Condenser Fans B4, B5, B21, and B22 (all units)

See table of contents for SPECIFICATIONS of condenser fans used in LGA/LCA/LHA units. All condenser fans used have single-phase motors. All units are equipped with four condenser fans. The complete fan assembly may be accessed for servicing and cleaning by removing the fan grill and turning the complete assembly until the motor brackets line up with the notches in the top panel. Lift the fan assembly out of the unit and disconnect the jack plug located on the motor.

C-Blower Compartment

The blower compartment in all LGA/LCA/LHA units is located between the evaporator coil and the compressor / control section on the opposite side of the condenser coil. The blower assembly is accessed by disconnecting the blower motor jack plug J98/P98 (and all other plugs) and removing the screws on either side of the sliding base. The base pulls out as shown in figure 14.

1-Blower Wheels (all units)

All 13 through 25 ton (46 through 88 kW) LGA/LCA/LHA units have two 15 in. x 15 in. (381 mm x 381 mm) blower wheels. Both wheels are driven by one motor.

2-Indoor Blower Motor B3 (all units)

All LGA/LCA/LHA units use three-phase single-speed blower motors. CFM adjustments are made by adjusting the motor pulley (sheave). Motors are equipped with sealed ball bearings. All motor specifications are listed in the tables on pages 3, 5, and 6. Units may be equipped with motors manufactured by various manufacturers, therefore electrical FLA and LRA specifications will vary. See unit rating plate for information specific to your unit.

OPERATION / ADJUSTMENT

Blower Operation

NOTE-The following is a generalized procedure and does not apply to all thermostat control systems.

- 1- Blower operation is dependent on the thermostat control system option that has been installed in the LGA/LCA/LHA units. Refer to operation sequence of the control system installed for detailed descriptions of blower operation.
- 2- Generally, blower operation is set at the thermostat fan switch. With the fan switch in "ON" position and the **OCF** input is "ON", the blower operates continuously. With the fan switch in "AUTO" position, the blower cycles with demand.
- 3- In most cases, the blower and entire unit will be off when the system switch is in the "OFF" position. The only exception is immediately after a heating demand when the blower control keeps the blower on until all heat is extracted from the heat exchanger.

Determining Unit Air Volume

- 1- The following measurements must be made with a dry indoor coil. Run blower without cooling demand. Air filters must be in place when measurements are taken.

- 2- With all access panels in place, measure static pressure external to unit (from supply to return).
- 3- Measure the indoor blower wheel RPM.
- 4- Refer to blower table on page 10, use static pressure and RPM readings to determine unit air volume. Use blower tables on pages 11 and 12 when installing units with the optional accessories listed.
- 5- The RPM can be adjusted at the motor pulley. Loosen Allen screw and turn adjustable pulley clockwise to increase RPM. Turn counterclockwise to decrease RPM. See figure 14.

Blower Belt Adjustment

Proper pulley alignment and belt tension must be maintained for maximum belt life.

NOTE-Tension new belt after 24-48 hours of operation. This will allow belts to stretch and seat in grooves.

- 1- Loosen four screws securing blower motor to sliding base. See figure 14.
- 2- *To increase belt tension* - Turn belt tension adjusting screw to the left, or counterclockwise, to tighten the belt. This increases the distance between the blower motor and the blower housing.
To loosen belt tension - Turn the adjusting screw to the right, or clockwise to loosen belt tension.
- 3- Tighten four screws securing blower motor to sliding base once adjustments have been made.

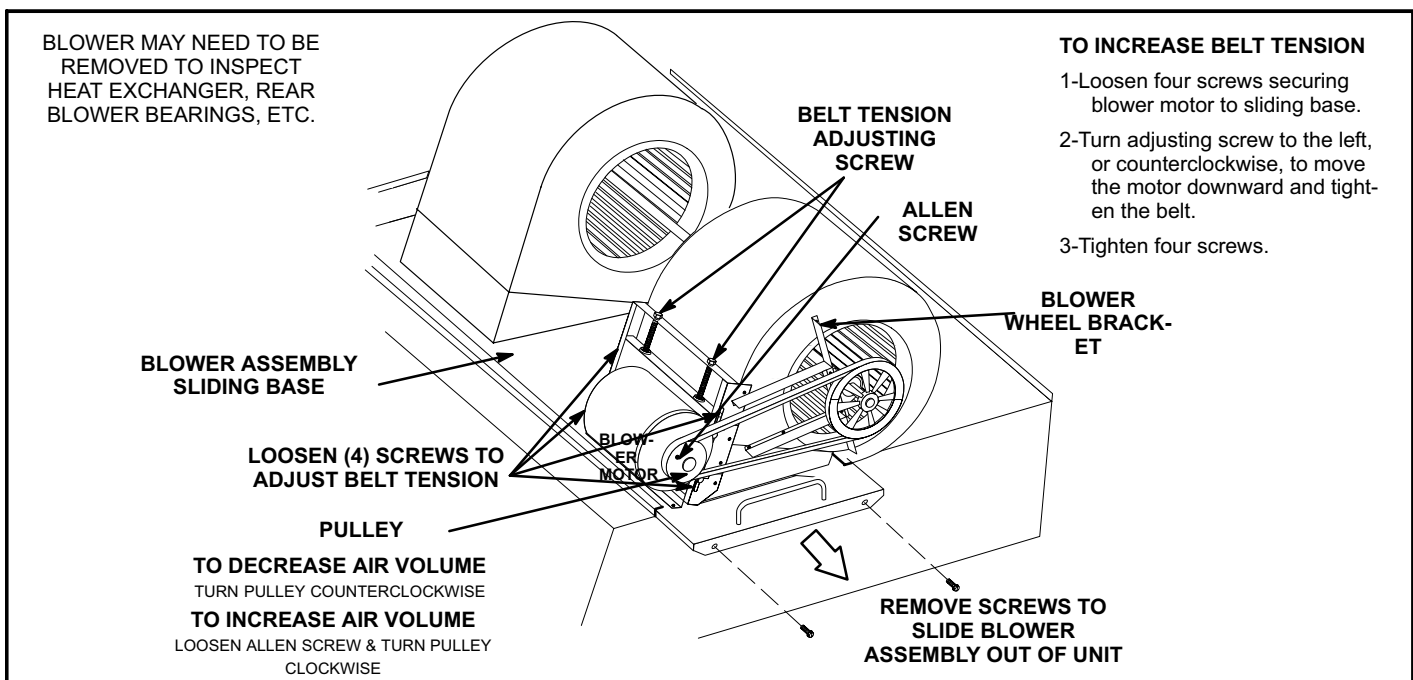

FIGURE 14

LGA240H Heat Exchanger (one heat section shown)

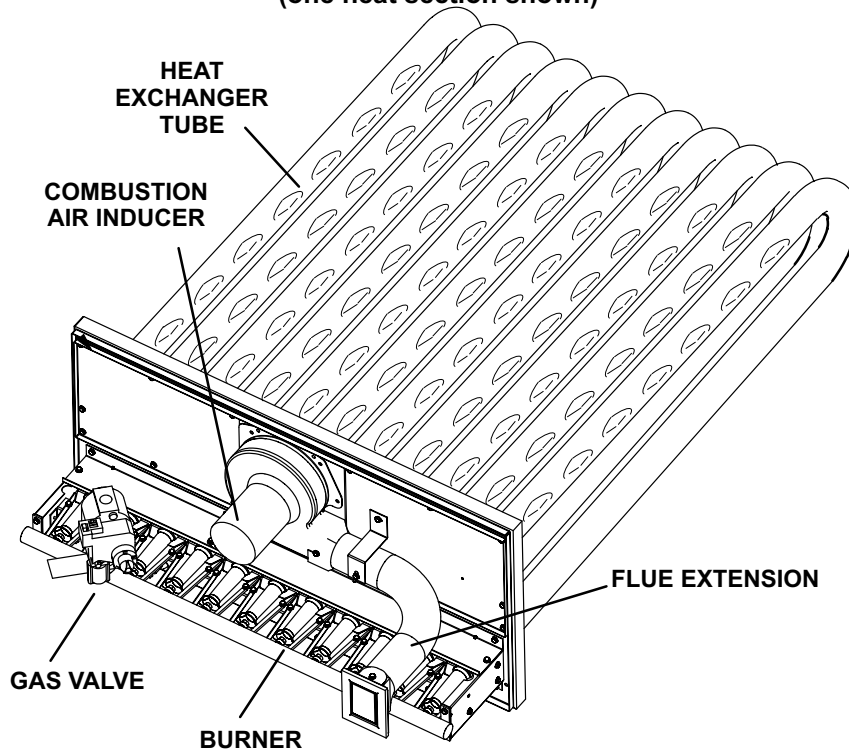

FIGURE 15

LGA Heat Exchanger

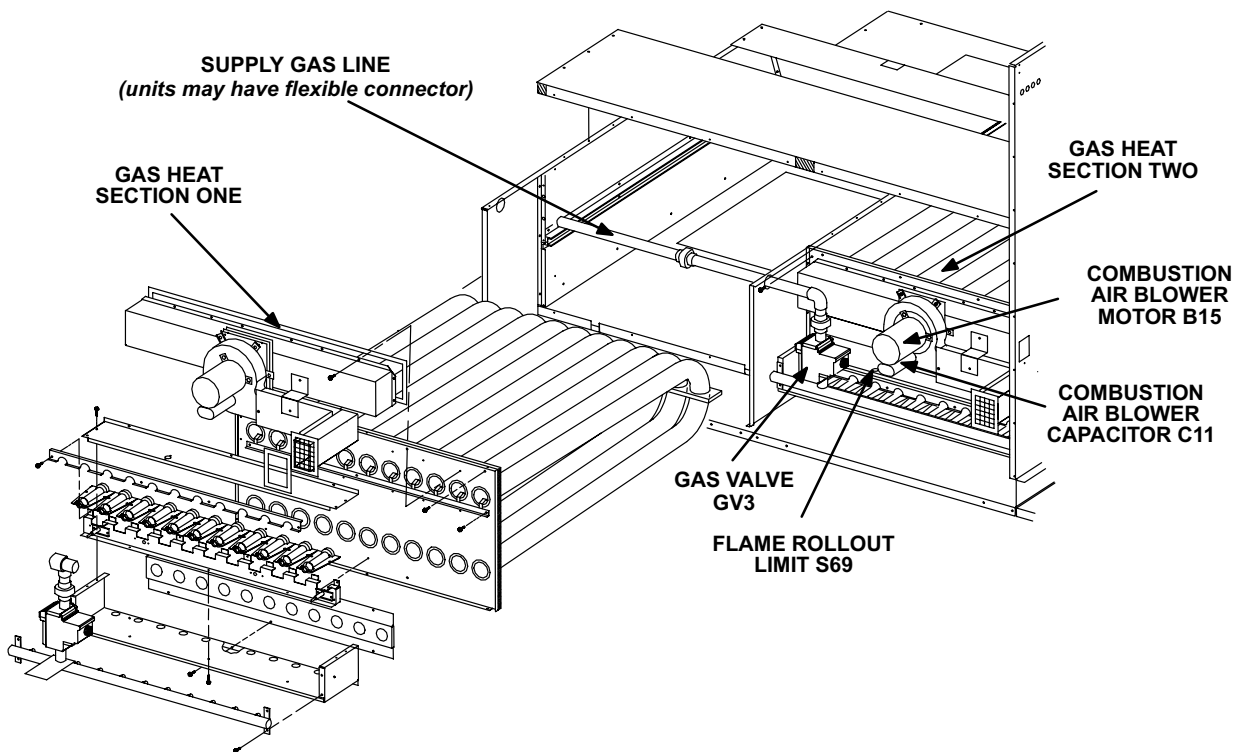

FIGURE 16

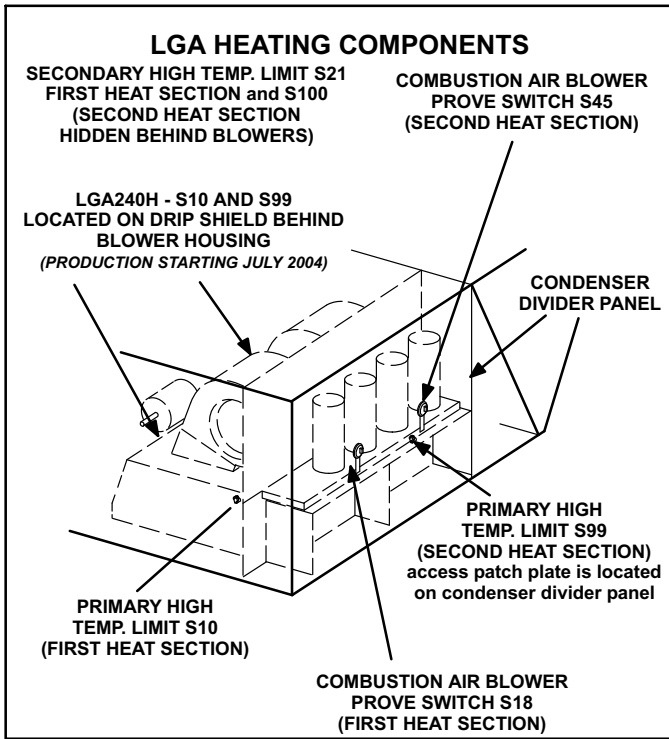

FIGURE 17

D-Gas Heat Components (all LGA units)

LGA156H units are available in 260,000 BTUH (76.2 kW) (standard gas heat only) and the LGA180/210/240/300S units are available in 260,000 BTUH (76.2 kW) (standard gas heat), or 470,000 BTUH (137.7 kW) (high gas heat) sizes. The LGA240H model is also available in 360,000 BTUH (105.5 kW) (medium gas heat) All units are equipped with two identical gas heat sections (gas heat section one and gas heat section two). Black steel pipe will feed supply gas to both sections. Late model units will have a flexible connection instead of cast iron pipe. If for service the flexible connection must be broken, hand tighten, then using a wrench turn additional 1/4 turn for metal to metal seal (*do not over tighten*).

NOTE-Do not use thread sealing compound on flex pipe flare connections.

1-Control Box Components

A3, A12, A55, A58, T3, T13, K13 and K19

⚠ WARNING

DISCONNECT POWER BEFORE SERVICING. CONTROLS ARE NOT FIELD REPAIRABLE. UNSAFE OPERATION WILL RESULT. IF CONTROLS ARE INOPERABLE, SIMPLY REPLACE THE ENTIRE CONTROL.

The main control box (see figure 4) houses the burner controls A3 and A12, main control module A55, gas valve (burner) control module A58, combustion air blower transformers T3 and T13, combustion air blower relay K13, and second heat section relay K19.

Burner Ignition Control A3 and A12

The ignition controls are located in the control box. Three different manufacturers' (Fenwal, Johnson Controls, and RAM) controls are used in the LGA units. All three ignition controls operate the same.

The ignition control provides three main functions: gas valve control, ignition, and flame sensing. The unit will usually ignite on the first attempt; however, the ignition attempt sequence provides three trials for ignition before locking out. The lockout time for the Johnson control is 5 minutes. The lockout time for the Fenwal control and RAM control is 1 hour. After lockout, the ignition control automatically resets and provides three more attempts at ignition. Manual reset after lockout requires breaking and remaking power to the ignition control. See figure 19 for a normal ignition sequence and figure 20 for the ignition attempt sequence with retries (nominal timings given for simplicity). Specific timings for the ignition controls are shown in figure 21.

TABLE 2

Manufacturer	LED Code	Description
RAM	Steady "ON"	Normal
	2 Flash	Reset Mode
	Steady Flash	Failure
Johnson	Steady "ON"	Normal
	.5 sec on / 2.5 sec off	Reset Mode
	"OFF"	No Power or Detected Failure

Flame rectification sensing is used on all LGA units. Loss of flame during a heating cycle is indicated by an absence of flame signal (0 microamps). If this happens, the control will immediately restart the ignition sequence and then lock out if ignition is not gained after the third trial. See Systems Service Checks section for flame current measurement.

The control shuts off gas flow immediately in the event of a power failure. Upon restoration of gas and power, the control will restart the ignition sequence and continue until flame is established or system locks out.

On a heating demand, the ignition control is energized by the main control module A55. The ignition control then allows 30 to 40 seconds for the combustion air blower to vent exhaust gases from the burners. When the combustion air blower is purging the exhaust gases, the combustion air prove switch is closing proving that the combustion air blower is operating before allowing the ignition control to energize. When the combustion air prove switch is closed and the delay is over, the ignition control activates gas valve, the spark electrode and the flame sensing electrode. Sparking stops immediately after flame is sensed. The combustion air blower continues to operate throughout the heating demand. If the flame fails or if the burners do not ignite, the ignition control will attempt to ignite the burners up to two more times. If ignition cannot be obtained after the third attempt, the control will lock out. The ignition control is not adjustable.

The RAM control is illustrated in figure 18. The four spade connections are used to connect the control to unit. Each of the four spade terminals are identified by function. The spark electrode wire connects to the spark-plug-type connector on top of the control.

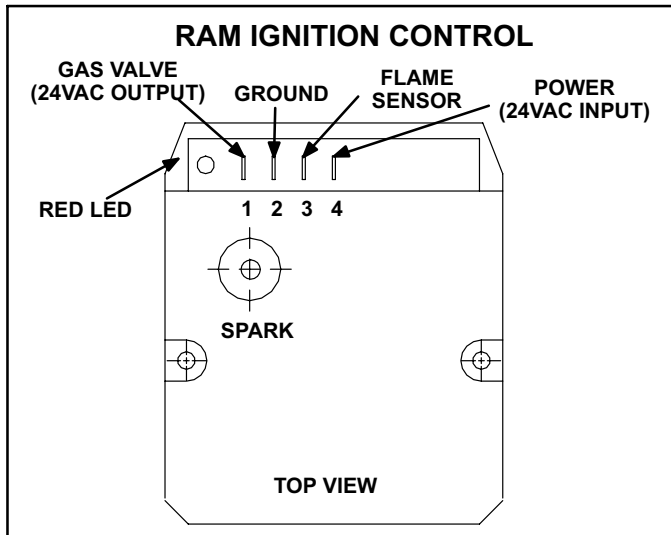

FIGURE 18

2-Heat Exchanger (Figures 15 and 16)

The LGA units use aluminized steel in shot burners with matching tubular aluminized (stainless steel is an option) steel heat exchangers and two-stage redundant gas valves. LGA uses two eleven tube/burners for high heat and two six tube/burners for low heat. The LGA240H uses two nine tube/burners for medium heat. Each burner uses a burner venturi to mix gas and air for proper combustion. Combustion takes place at each tube entrance. As hot combustion gases are drawn upward through each tube by the combustion air inducer, exhaust gases are drawn out the top and fresh air/gas mixture is drawn in at the bottom. Heat is transferred to the air stream from all surfaces of the heat exchanger tubes. The supply air blowers, controlled by the main control panel A55, force air across all surfaces of the tubes to extract the heat of combustion. The shape of the tubes ensures maximum heat exchange.

The gas valves accomplish staging by allowing more or less gas to the burners as called for by heating demand.

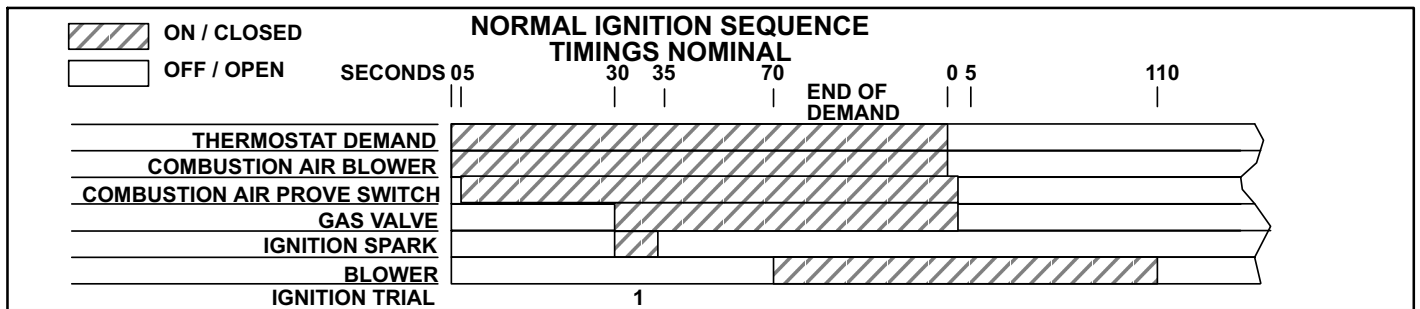

FIGURE 19

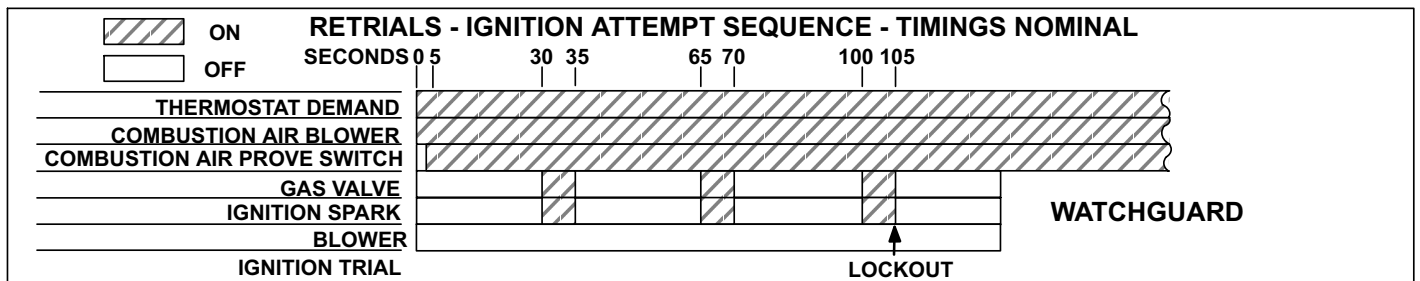

FIGURE 20

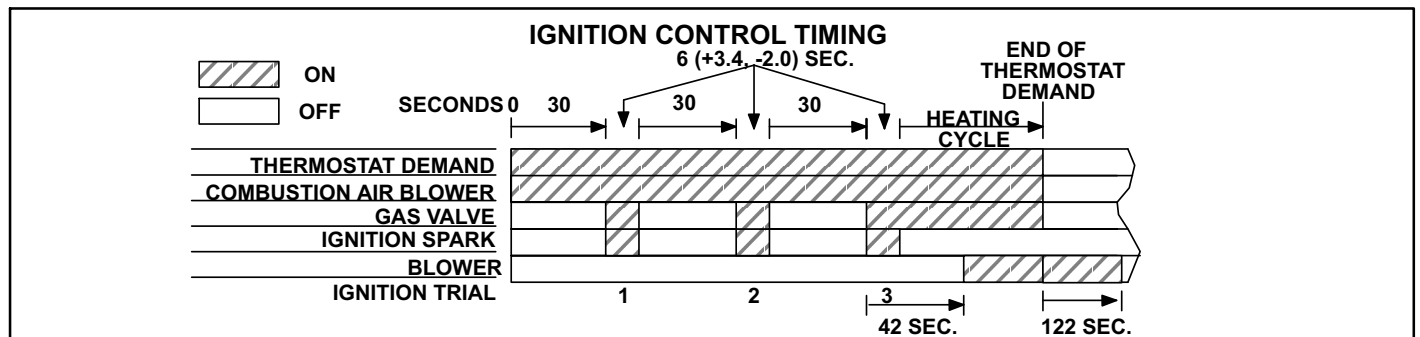

FIGURE 21

3-Burner Assembly (Figure 22)

The burners are controlled by the spark electrode, flame sensing electrode, gas valve and combustion air inducer. The spark electrode, flame sensing electrode and gas valve are directly controlled by ignition control. Ignition control and combustion air inducer is controlled by main control panel A55.

Burners

All units use inshot burners (see figures 22 and 23). Burners are factory set and do not require adjustment. A peep hole with cover is furnished in the heating access panel for flame viewing. Always operate the unit with the access panel in place.

Burners can be removed individually for service. Burner maintenance and service is detailed in the SERVICE CHECKS sections of this manual.

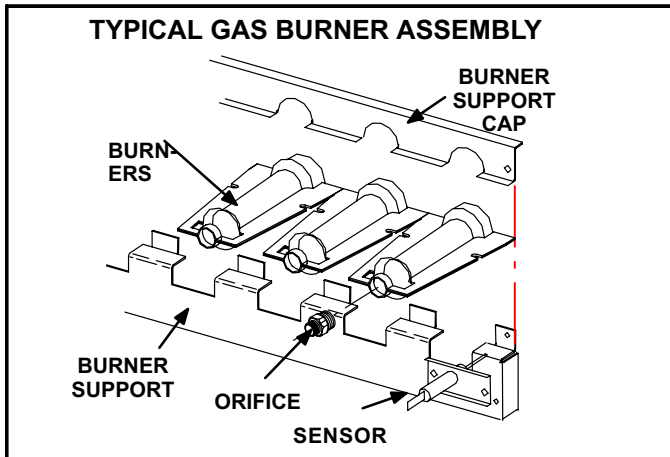

FIGURE 22

Orifice

Each burner uses an orifice which is precisely matched to the burner input. The orifice is threaded into the burner manifold. The burner is supported by the orifice and will easily slide off for service.

NOTE-Do not use thread sealing compound on the orifices. Using thread sealing compound may plug the orifices.

Each orifice and burner are sized specifically to the unit. Refer to Lennox Repair Parts Listing for correct sizing information.

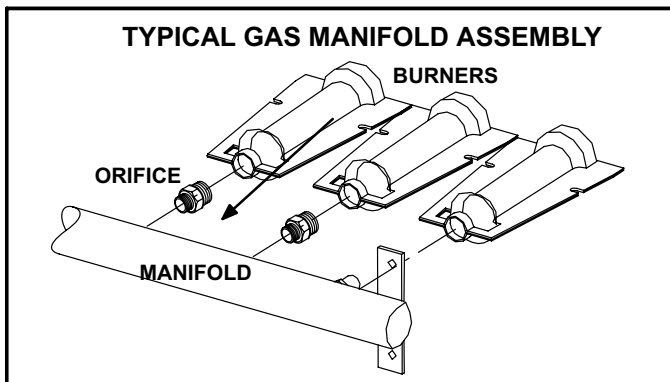

FIGURE 23

NOTE-In primary and secondary high temperature limits S10, S99, S21, and S100 the ignition circuits in both gas heat sections one and two are immediately de-energized when terminals 1-3 open and the indoor blower motor is immediately energized when terminals 1-2 close. This is the primary and secondary safety shut-down function of the unit.

4-Primary High Temperature Limits

S10 & S99

S10 is the primary high temperature limit for gas heat section one, while S99 is the primary high temperature limit for gas heat section two. S10 is located in the blower compartment and is mounted on the end of the blower support panel which divides the blower compartment from the heating compartment (see figure 17). S99 is located on the blower support panel which separates the second gas heat section from the outdoor condenser section (see figure 17).

Figure 17 also shows the location of S10 and S99 in LGA240H units. S10 and S99 are located on the drip shield behind the blower housing. In this location S10 and S99 serve as both primary and secondary limit.

Primary limit S10 is wired to the main control panel A55 which energizes burner 1 control (A3), while primary limit S99 is wired to the gas 2 panel A58 which energizes burner 2 control (A12). Its N.C. contacts open to de-energize the ignition control when excessive temperature is reached in the blower compartment. At the same time, the N.O. contacts of S10 and S99 close energizing the blower relay coil K3 through control A55. If either limit trips the blower will be energized.

Limit set points are factory set and cannot be adjusted. If limit must be replaced same type and set point must be used. See Lennox Repair Parts Handbook .

5-Secondary High Temperature Limits

S21 & S100

S21 is the secondary high temperature limit for heat section one, while S100 is the secondary high temperature limit for heat section two. Like the primary limits, the secondary limits are located in the blower compartment. S21 and S100 are mounted on top of the blowers (see figure 17).

Secondary limit S21 is also wired to the main control panel A55, while secondary limit S100 is wired to the gas 2 panel A58. The secondary limits function in the same manner as the primary limits, but are factory set to actuate at different temperatures. The N.O. contacts of both S21 and S100 are connected to the blower relay coil K3 through control A55. If either limit trips the blower will be energized. All limits used are SPDT N.C. auto-reset limits.

Limit set points are factory set and cannot be adjusted. If limit must be replaced same type and set point must be used. See Lennox Repair Parts Handbook .

6-Flame Rollout Limits S47 and S69

Flame rollout limits S47 (first heat section) and S69 (second heat section) are SPST N.C. high temperature limits located just above the burner air intake opening in the burner enclosures (see figure 16). S47 is wired to the main control panel A55, while S69 is wired to the gas 2 panel A58. When S47 or S69 senses flame rollout (indicating a blockage in the combustion air passages), the corresponding flame rollout limit trips, and the ignition control immediately closes the gas valve.

Limit S47 and S69 in standard heat units are factory preset to open at $250^{\circ}\text{F} \pm 12^{\circ}\text{F}$ ($121.1^{\circ}\text{C} \pm 6.7^{\circ}\text{C}$) on a temperature rise, while on high heat units both limits open at $270^{\circ}\text{F} \pm 12^{\circ}\text{F}$ ($132.2^{\circ}\text{C} \pm 6.7^{\circ}\text{C}$) on a temperature rise. All flame rollout limits are manual reset.

7-Combustion Air Prove Switches S18 & S45

Prove switches S18 (first heat section) and S45 (second heat section) are located in the compressor compartment. Both are SPST N.O. switches and are identical and monitor combustion air inducer operation. Switch S18 is wired to the main control panel A55, while S45 is wired to the gas 2 panel A58. The switch will automatically close on a *negative* pressure $0.46'' \text{ W.C.} \pm 0.05'' \text{ W.C.}$ ($114.6 \text{ Pa} \pm 12.4 \text{ Pa}$). This pressure fall and switch actuation allows power to the ignition control (proves, by closing, that the combustion air blower is operating before allowing the ignition control to energize.) The switch will open at $0.31'' \text{ W.C.} \pm 0.05''$ ($77.2 \text{ Pa} \pm 12.4 \text{ Pa}$) on pressure rise (less negative). The combustion air prove switch is factory set and not adjustable.

8-Combustion Air Blowers B6 and B15

Combustion air blowers B6 (first heat section) and B15 (second heat section) are identical blowers which provide fresh air to the corresponding burners while clearing the combustion chamber of exhaust gases. The blowers begin operating immediately upon receiving a thermostat demand and are de-energized immediately when thermostat demand is satisfied.

Both combustion air blowers use a 208/230V single-phase PSC motor and a 4.81in. x 1.25in. (122mm x 32mm) blower wheel. All motors operate at 3200RPM and are equipped with auto-reset overload protection. Blowers are supplied by various manufacturers. Ratings may vary by manufacturer. Specific blower electrical ratings can be found on the unit rating plate.

All combustion air blower motors are sealed and cannot be oiled. The blower cannot be adjusted but can be disassembled for cleaning.

9-Combustion Air Motor Capacitors C3 & C11

The combustion air blower motors in all LGA units require run capacitors. Capacitor C3 is connected to combustion air blower B6 and C11 is connected to combustion air blower B15. Both capacitors are rated at 3 MFD and 370VAC.

10-Gas Valves GV1 and GV3

Gas valves GV1 and GV3 are identical. The gas valves are two-stage redundant valves. Units are equipped with valves manufactured by White-Rodgers or Honeywell. On both valves first stage (low fire) is quick opening (on and off in less than 3 seconds). On the White-Rodgers valve second stage is slow opening (on to high fire pressure in 40 seconds and off to low fire pressure in 30 seconds). On the Honeywell second stage is quick opening. On a call for first stage heat (low fire), the valve is energized by the ignition control simultaneously with the spark electrode. On a call for second stage heat (high fire), the second stage operator is energized directly from A55 (GV1) and A58 (GV3). The White-Rodgers valve is adjustable for high fire only. Low fire is not adjustable. The Honeywell valve is adjustable for both low fire and high fire. A manual shut-off knob is provided on the valve for shut-off. Manual shut-off knob immediately closes both stages without delay. Figure 24 shows gas valve components. Table 3 shows factory gas valve regulation for LGA series units. Optional factory installed gas valves for single stage heat only, are available for the LGA180H. Gas valves are wired without W2 eliminating two stage heat.

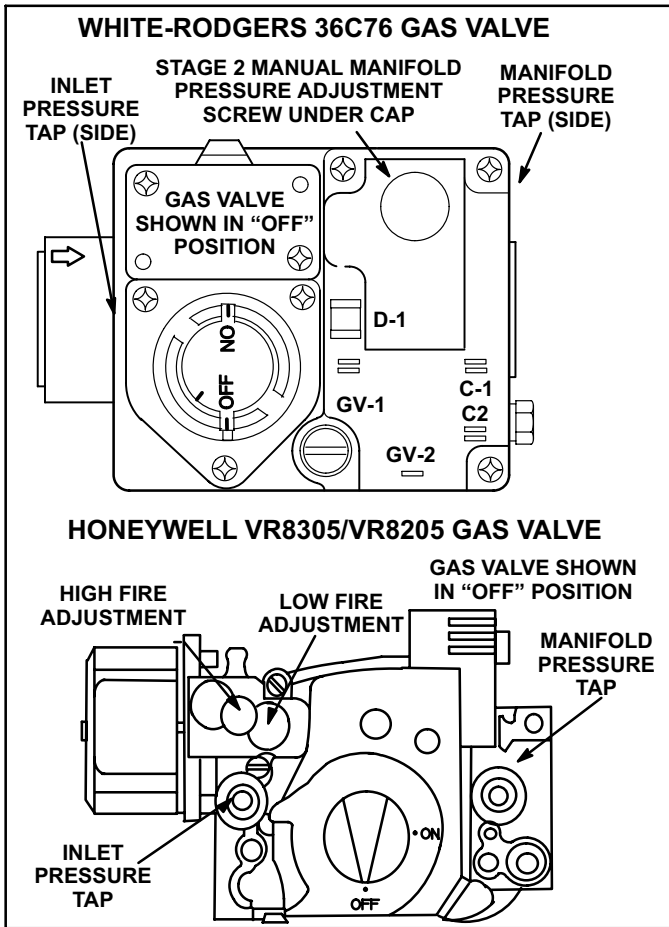

FIGURE 24

TABLE 3

GAS VALVE REGULATION FOR LGA UNITS				
Maximum Inlet Pressure	Operating Pressure (outlet) Factory Setting			
	Natural		L.P	
	Low	High	Low	High
13.0"W.C. 3232Pa	1.6±0.2"W.C. 398±50Pa	3.7±0.3"W.C. 920±75Pa	5.5±0.3"W.C. 1368±75Pa	10.5±0.5"W.C. 2611±7124Pa

11-Spark Electrodes

An electrode assembly is used for ignition spark. Two identical electrodes are used (one for each gas heat section). The electrode is mounted through holes on the left-most end of the burner support. The electrode tip protrudes into the flame envelope of the adjacent burner. The electrode assembly is fastened to burner supports and can be removed for service without removing any part of the burners.

During ignition, spark travels through the spark electrode (figure 25) and ignites the left burner. Flame travels from burner to burner until all are lit.

The spark electrode is connected to the ignition control by a 8 mm silicone-insulated stranded high voltage wire. The wire uses 1/4" (6.35 mm) female quick connect on the electrode end and female spark plug-type terminal on the ignition control end.

NOTE-IN ORDER TO MAXIMIZE SPARK ENERGY TO ELECTRODE, HIGH VOLTAGE WIRE SHOULD TOUCH UNIT CABINET AS LITTLE AS POSSIBLE.

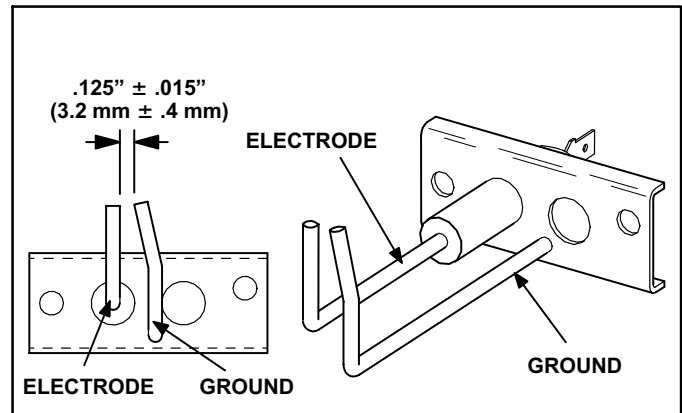

FIGURE 25

12-Flame Sensors

A flame sensor is located on the right side of each burner support. The sensor is mounted through a hole in the burner support and the tip protrudes into the flame envelope of the right most burner. The sensor assembly is fastened to burner supports and can be removed for service without removing any part of the burners.

When flame is sensed by the flame sensor (indicated by microamp signal through the flame) sparking stops immediately. During operation, flame is sensed by current passed along the ground electrode (located on the spark electrode), through the flame and into the sensing electrode. The ignition control allows the gas valve to stay open as long as a flame signal (current passed through the flame) is sensed.

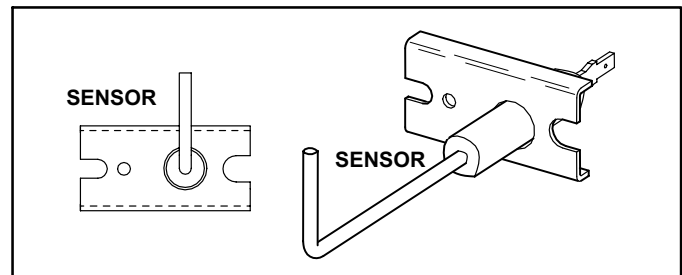

FIGURE 26

**ELECTRIC HEAT DATA
TABLE 4**

LCA156 - OPTIONAL ELECTRIC HEAT DATA (Requires Unit Fuse Block, Terminal Block and ② Heater Control Module)										
Electric Heat Model No. & Net Weight	No. of Steps	Volts Input	kW Input	Btuh Output	†Total Unit + Electric Heat Minimum Circuit Ampacity (with Power Exhaust Fans)			Total Unit + Electric Heat Maximum Fuse Size (with Power Exhaust Fans)		
					2 hp (1.5 kW)	3 hp (2.2 kW)	5 hp (3.7 kW)	2 hp (1.5 kW)	3 hp (2.2 kW)	5 hp (3.7 kW)
15 kW Order One Each: EHA240-7.5 + EHA240S-7.5 208/230V 99J16 + 99J17 460V 99J18 + 99J19 575V 99J20 + 99J21 59 lbs. (27 kg) (total weight)	1	208	11.3	38,600	70	73	79	80	80	90
	1	220	12.6	43,000	70	73	79	80	80	90
	1	230	13.8	47,100	70	73	79	80	80	90
	1	240	15.0	51,200	70	73	79	80	80	90
	1	440	12.6	43,000	35	36	39	40	40	45
	1	460	13.8	47,100	35	36	39	40	40	45
	1	480	15.0	51,200	35	36	39	40	40	45
	1	550	12.6	43,000	26	27	29	30	30	35
30 kW Order One Each: EHA156-15 + EHA156S-15 208/230V 86K55 + 86K58 460V 86K56 + 86K59 575V 86K57 + 86K60 59 lbs. (27 kg) (total weight)	1	208	22.5	76,800	106	110	118	110	110	125
	1	220	25.2	86,000	106	110	118	110	110	125
	1	230	27.5	93,900	106	110	118	110	110	125
	1	240	30.0	102,400	106	110	118	110	110	125
	1	440	25.2	86,000	53	55	58	60	60	60
	1	460	27.5	93,900	53	55	58	60	60	60
	1	480	30.0	102,400	53	55	58	60	60	60
	1	550	25.2	86,000	42	44	47	45	45	50
45 kW Order Two Each: EHA156-22.5 208/230V 86K10 + 86K10 460V 86K11 + 86K11 575V 86K12 + 86K12 76 lbs. (35 kg) (total weight)	①2	208	33.8	115,300	151	155	163	175	175	175
	①2	220	37.8	129,000	151	155	163	175	175	175
	①2	230	41.3	141,000	151	155	163	175	175	175
	①2	240	45.0	153,600	151	155	163	175	175	175
	①2	440	37.8	129,000	76	77	81	80	80	90
	①2	460	41.3	141,000	76	77	81	80	80	90
	①2	480	45.0	153,600	76	77	81	80	80	90
	①2	550	37.8	129,000	60	62	65	60	70	70
60 kW Order Two each: EHA156-30 208/230V 86K13 + 86K13 460V 86K14 + 86K14 575V 86K15 + 86K15 76 lbs. (35 kg) (total weight)	①2	208	45.0	153,600	160	164	172	175	175	175
	①2	220	50.4	172,000	160	164	172	175	175	175
	①2	230	55.1	188,000	160	164	172	175	175	175
	①2	240	60.0	204,800	160	164	172	175	175	175
	①2	440	50.4	172,000	80	82	85	80	90	90
	①2	460	55.1	188,000	80	82	85	80	90	90
	①2	480	60.0	204,800	80	82	85	80	90	90
	①2	550	50.4	172,000	64	66	68	70	70	70

†Refer to National or Canadian Electrical Code manual to determine wire, fuse and disconnect size requirements. Use wires suitable for at least 167°F (75°C).





















① May be used with two stage control.

② Electric Heat Control Module required on 45, 60 & 90 kW sizes only (module furnished with factory installed electric heaters). See Optional Electric Heat Accessories tables.
NOTE — Fuse block must be ordered extra. Factory installed heaters will have the fuse block factory installed. Fuse block must be installed in field installed heaters. Also requires LTB2 Terminal Block. See Optional Electric Heat Accessories tables.

TABLE 5

LCA180 - OPTIONAL ELECTRIC HEAT DATA

(Requires Unit Fuse Block, Terminal Block and  Heater Control Module)

Electric Heat Model No. & Net Weight	No. of Steps	Volts Input	kW Input	Btuh Output	†Total Unit + Electric Heat Minimum Circuit Ampacity (with Power Exhaust Fans)			Total Unit + Electric Heat Maximum Fuse Size (with Power Exhaust Fans)			
					3 hp (2.2 kW)	5 hp (3.7 kW)	7.5 hp (5.6 kW)	3 hp (2.2 kW)	5 hp (3.7 kW)	7.5 hp (5.6 kW)	
15 kW Order One Each: EHA240-7.5 + EHA240S-7.5 208/230V 99J16 + 99J17 460V 99J18 + 99J19 575V 99J20 + 99J21 59 lbs. (27 kg) (total weight)	1	208	11.3	38,600	180S - 76 180H - 82	180S - 82 180H - 88	180S - 89 180H - 95	90	180S - 90 180H - 100	180S - 110 180H - 110	
	1	220	12.6	43,000	180S - 76 180H - 82	180S - 82 180H - 88	180S - 89 180H - 95	90	180S - 90 180H - 100	180S - 110 180H - 110	
	1	230	13.8	47,100	180S - 76 180H - 82	180S - 82 180H - 88	180S - 89 180H - 95	90	180S - 90 180H - 100	180S - 110 180H - 110	
	1	240	15.0	51,200	180S - 76 180H - 82	180S - 82 180H - 88	180S - 89 180H - 95	90	180S - 90 180H - 100	180S - 110 180H - 110	
	1	440	12.6	43,000	180S - 37 180H - 42	180S - 40 180H - 45	180S - 43 180H - 49	180S - 40 180H - 50	180S - 45 180H - 50	50	
	1	460	13.8	47,100	180S - 37 180H - 42	180S - 40 180H - 45	180S - 43 180H - 49	180S - 40 180H - 50	180S - 45 180H - 50	50	
	1	480	15.0	51,200	180S - 37 180H - 42	180S - 40 180H - 45	180S - 43 180H - 49	180S - 40 180H - 50	180S - 45 180H - 50	50	
	1	550	12.6	43,000	180S - 30 180H - 33	180S - 32 180H - 36	180S - 35 180H - 39	180S - 35 180H - 40	180S - 35 180H - 40	180S - 40 180H - 45	
	1	575	13.8	47,100	180S - 30 180H - 33	180S - 32 180H - 36	180S - 35 180H - 39	180S - 35 180H - 40	180S - 35 180H - 40	180S - 40 180H - 45	
1	600	15.0	51,200	180S - 30 180H - 33	180S - 32 180H - 36	180S - 35 180H - 39	180S - 35 180H - 40	180S - 35 180H - 40	180S - 40 180H - 45		
30 kW Order One Each: EHA360-15 + EHA360S-15 208/230V 99J22 + 99J23 460V 99J24 + 99J25 575V 99J26 + 99J27 59 lbs. (27 kg) (total weight)	1	208	22.5	76,800	110	118	127	110	125	150	
	1	220	25.2	86,000	110	118	127	110	125	150	
	1	230	27.5	93,900	110	118	127	110	125	150	
	1	240	30.0	102,400	110	118	127	110	125	150	
	1	440	25.2	86,000	55	58	63	60	60	70	
	1	460	27.5	93,900	55	58	63	60	60	70	
	1	480	30.0	102,400	55	58	63	60	60	70	
	1	550	25.2	86,000	44	47	50	45	50	50	
1	575	27.5	93,900	44	47	50	45	50	50		
1	600	30.0	102,400	44	47	50	45	50	50		
45 kW Order Two Each: EHA360-22.5 208/230V 99J28 + 99J28 460V 99J29 + 99J29 575V 99J30 + 99J30 76 lbs. (35 kg) (total weight)		208	33.8	115,300	155	163	172	175	175	175	
		220	37.8	129,000	155	163	172	175	175	175	
		230	41.3	141,000	155	163	172	175	175	175	
		240	45.0	153,600	155	163	172	175	175	175	
		440	37.8	129,000	77	81	85	80	90	90	
		460	41.3	141,000	77	81	85	80	90	90	
		480	45.0	153,600	77	81	85	80	90	90	
		550	37.8	129,000	62	65	68	70	70	70	
		575	41.3	141,000	62	65	68	70	70	70	
		600	45.0	153,600	62	65	68	70	70	70	
	60 kW Order Two Each: EHA150-30 208/230V 99J07 + 99J07 460V 99J08 + 99J08 575V 99J09 + 99J09 76 lbs. (35 kg) (total weight)		208	45.0	153,600	164	172	181	175	175	200
			220	50.4	172,000	164	172	181	175	175	200
		230	55.1	188,000	164	172	181	175	175	200	
		240	60.0	204,800	164	172	181	175	175	200	
		440	50.4	172,000	82	85	90	90	90	90	
		460	55.1	188,000	82	85	90	90	90	90	
		480	60.0	204,800	82	85	90	90	90	90	
		550	50.4	172,000	66	68	72	70	70	80	
		575	55.1	188,000	66	68	72	70	70	80	
		600	60.0	204,800	66	68	72	70	70	80	

†Refer to National or Canadian Electrical Code manual to determine wire, fuse and disconnect size requirements. Use wires suitable for at least 167°F (75°C).

 May be used with two stage control.

 Electric Heat Control Module required on 45, 60 & 90 kW sizes only (module furnished with factory installed electric heaters). See Optional Electric Heat Accessories tables.

NOTE — Fuse block must be ordered extra. Factory installed heaters will have the fuse block factory installed. Fuse block must be installed in field installed heaters. Also requires LTB2 Terminal Block. See Optional Electric Heat Accessories tables.

TABLE 6

LCA210 - OPTIONAL ELECTRIC HEAT DATA (Requires Unit Fuse Block, Terminal Block & <input type="checkbox"/> Heater Control Module)										
Electric Heat Model No. & Net Weight	No. of Steps	Volts Input	kW Input	Btuh Output	†Total Unit + Electric Heat Minimum Circuit Ampacity (with Power Exhaust Fans)			Total Unit + Electric Heat Maximum Fuse Size (with Power Exhaust Fans)		
					3 hp (2.2 kW)	5 hp (3.7 kW)	7.5 hp (5.6 kW)	3 hp (2.2 kW)	5 hp (3.7 kW)	7.5 hp (5.6 kW)
15 kW Order One Each: EHA240-7.5 + EHA240S-7.5 208/230V 99J16 + 99J17 460V 99J18 + 99J19 575V 99J20 + 99J21 59 lbs. (27 kg) (total weight)	1	208	11.3	38,600	210S - 88 210H - 83	210S - 94 210H - 89	210S - 102 210H - 96	100	110	125
	1	220	12.6	43,000	210S - 88 210H - 83	210S - 94 210H - 89	210S - 102 210H - 96	100	110	125
	1	230	13.8	47,100	210S - 88 210H - 83	210S - 94 210H - 89	210S - 102 210H - 96	100	110	125
	1	240	15.0	51,200	210S - 88 210H - 83	210S - 94 210H - 89	210S - 102 210H - 96	100	110	125
	1	440	12.6	43,000	210S - 43 210H - 45	210S - 47 210H - 46	210S - 51 210H - 49	45	50	60
	1	460	13.8	47,100	210S - 43 210H - 45	210S - 47 210H - 46	210S - 51 210H - 49	45	50	60
	1	480	15.0	51,200	210S - 43 210H - 45	210S - 47 210H - 46	210S - 51 210H - 49	45	50	60
	1	550	12.6	43,000	210S - 36 210H - 32	37	210S - 40 210H - 37	210S - 40 210H - 35	40	45
1	575	13.8	47,100	210S - 36 210H - 32	37	210S - 40 210H - 37	210S - 40 210H - 35	40	45	
1	600	15.0	51,200	210S - 36 210H - 32	37	210S - 40 210H - 37	210S - 40 210H - 35	40	45	
30 kW Order One Each: EHA360-15 + EHA360S-15 208/230V 99J22 + 99J23 460V 99J24 + 99J25 575V 99J26 + 99J27 59 lbs. (27 kg) (total weight)	1	208	22.5	76,800	110	118	127	110	125	150
	1	220	25.2	86,000	110	118	127	110	125	150
	1	230	27.5	93,900	110	118	127	110	125	150
	1	240	30.0	102,400	110	118	127	110	125	150
	1	440	25.2	86,000	55	58	63	60	60	70
	1	460	27.5	93,900	55	58	63	60	60	70
	1	480	30.0	102,400	55	58	63	60	60	70
	1	550	25.2	86,000	44	47	50	45	50	50
1	575	27.5	93,900	44	47	50	45	50	50	
1	600	30.0	102,400	44	47	50	45	50	50	
45 kW Order Two Each: EHA360-22.5 208/230V 99J28 + 99J28 460V 99J29 + 99J29 575V 99J30 + 99J30 76 lbs. (35 kg) (total weight)	<input type="checkbox"/> 2	208	33.8	115,300	155	163	172	175	175	175
	<input type="checkbox"/> 2	220	37.8	129,000	155	163	172	175	175	175
	<input type="checkbox"/> 2	230	41.3	141,000	155	163	172	175	175	175
	<input type="checkbox"/> 2	240	45.0	153,600	155	163	172	175	175	175
	<input type="checkbox"/> 2	440	37.8	129,000	77	81	85	80	90	90
	<input type="checkbox"/> 2	460	41.3	141,000	77	81	85	80	90	90
	<input type="checkbox"/> 2	480	45.0	153,600	77	81	85	80	90	90
	<input type="checkbox"/> 2	550	37.8	129,000	62	65	68	70	70	70
<input type="checkbox"/> 2	575	41.3	141,000	62	65	68	70	70	70	
<input type="checkbox"/> 2	600	45.0	153,600	62	65	68	70	70	70	
60 kW Order Two Each: EHA150-30 208/230V 99J07 + 99J07 460V 99J08 + 99J08 575V 99J09 + 99J09 76 lbs. (35 kg) (total weight)	<input type="checkbox"/> 2	208	45.0	153,600	164	172	181	175	175	200
	<input type="checkbox"/> 2	220	50.4	172,000	164	172	181	175	175	200
	<input type="checkbox"/> 2	230	55.1	188,000	164	172	181	175	175	200
	<input type="checkbox"/> 2	240	60.0	204,800	164	172	181	175	175	200
	<input type="checkbox"/> 2	440	50.4	172,000	82	85	90	90	90	90
	<input type="checkbox"/> 2	460	55.1	188,000	82	85	90	90	90	90
	<input type="checkbox"/> 2	480	60.0	204,800	82	85	90	90	90	90
	<input type="checkbox"/> 2	550	50.4	172,000	66	68	72	70	70	80
<input type="checkbox"/> 2	575	55.1	188,000	66	68	72	70	70	80	
<input type="checkbox"/> 2	600	60.0	204,800	66	68	72	70	70	80	
90 kW Order Two Each: EHA360-45 208/230V 99J31 + 99J31 460V 99J32 + 99J32 575V 99J33 + 99J33 84 lbs. (38 kg) (total weight)	<input type="checkbox"/> 2	208	67.6	230,700	236	244	253	250	250	<input type="checkbox"/> 300
	<input type="checkbox"/> 2	220	75.6	258,000	236	244	253	250	250	<input type="checkbox"/> 300
	<input type="checkbox"/> 2	230	82.7	282,200	236	244	253	250	250	<input type="checkbox"/> 300
	<input type="checkbox"/> 2	240	90.0	307,100	236	244	253	250	250	<input type="checkbox"/> 300
	<input type="checkbox"/> 2	440	75.6	258,000	118	122	126	125	125	150
	<input type="checkbox"/> 2	460	82.7	282,200	118	122	126	125	125	150
	<input type="checkbox"/> 2	480	90.0	307,100	118	122	126	125	125	150
	<input type="checkbox"/> 2	550	75.6	258,000	94	97	101	100	100	110
<input type="checkbox"/> 2	575	82.7	282,200	94	97	101	100	100	110	
<input type="checkbox"/> 2	600	90.0	307,100	94	97	101	100	100	110	

†Refer to National or Canadian Electrical Code manual to determine wire, fuse and disconnect size requirements. Use wires suitable for at least 167°F (75°C).
 May be used with two stage control.
 Electric Heat Control Module required on 45, 60 & 90 kW sizes only (module furnished with factory installed electric heaters). See Optional Electric Heat Accessories tables.
 Factory installed circuit breaker not available.
 NOTE — Fuse block must be ordered extra. Factory installed heaters will have the fuse block factory installed. Fuse block must be installed in field installed heaters. Also requires LTB2 Terminal Block. See Optional Electric Heat Accessories tables.

TABLE 7

LCA240 - OPTIONAL ELECTRIC HEAT DATA

(Requires Unit Fuse Block, Terminal Block and ② Heater Control Module)

Electric Heat Model No. & Net Weight	No. of Steps	Volts Input	kW Input	Btuh Output	Minimum Circuit Ampacity - †Total Unit + Electric Heat + Power Exhaust Fans			Maximum Fuse Size - †Total Unit + Electric Heat + Power Exhaust Fans		
					5 hp (3.7 kW)	7.5 hp (5.6 kW)	10 hp (7.5 kW)	5 hp (3.7 kW)	7.5 hp (5.6 kW)	10 hp (7.5 kW)
15 kW Order One Each: EHA240-7.5 + EHA240S-7.5 208/230V 99J16 + 99J17 460V 99J18 + 99J19 575V 99J20 + 99J21 59 lbs. (27 kg) (total weight)	1	208	11.3	38,600	240S - 97 240H - 105	240S - 105 240H - 113	240S - 111 240H - 119	110	125	240S - 125 240H - 150
	1	220	12.6	43,000	240S - 97 240H - 105	240S - 105 240H - 113	240S - 111 240H - 119	110	125	240S - 125 240H - 150
	1	230	13.8	47,100	240S - 97 240H - 105	240S - 105 240H - 113	240S - 111 240H - 119	110	125	240S - 125 240H - 150
	1	240	15.0	51,200	240S - 97 240H - 105	240S - 105 240H - 113	240S - 111 240H - 119	110	125	240S - 125 240H - 150
	1	440	12.6	43,000	240S - 47 240H - 54	240S - 51 240H - 58	240S - 54 240H - 61	240S - 50 240H - 60	60	240S - 60 240H - 70
	1	460	13.8	47,100	240S - 47 240H - 54	240S - 51 240H - 58	240S - 54 240H - 61	240S - 50 240H - 60	60	240S - 60 240H - 70
	1	480	15.0	51,200	240S - 47 240H - 54	240S - 51 240H - 58	240S - 54 240H - 61	240S - 50 240H - 60	60	240S - 60 240H - 70
	1	550	12.6	43,000	240S - 38 240H - 43	240S - 41 240H - 46	240S - 43 240H - 48	240S - 40 240H - 45	240S - 45 240H - 50	240S - 50 240H - 50
1	575	13.8	47,100	240S - 38 240H - 43	240S - 41 240H - 46	240S - 43 240H - 48	240S - 40 240H - 45	240S - 45 240H - 50	240S - 50 240H - 50	
1	600	15.0	51,200	240S - 38 240H - 43	240S - 41 240H - 46	240S - 43 240H - 48	240S - 40 240H - 45	240S - 45 240H - 50	240S - 50 240H - 50	
30 kW Order One Each: EHA360-15 + EHA360S-15 208/230V 99J22 + 99J23 460V 99J24 + 99J25 575V 99J26 + 99J27 59 lbs. (27 kg) (total weight)	1	208	22.5	76,800	118	127	135	125	150	150
	1	220	25.2	86,000	118	127	135	125	150	150
	1	230	27.5	93,900	118	127	135	125	150	150
	1	240	30.0	102,400	118	127	135	125	150	150
	1	440	25.2	86,000	58	63	66	60	70	70
	1	460	27.5	93,900	58	63	66	60	70	70
	1	480	30.0	102,400	58	63	66	60	70	70
	1	550	25.2	86,000	47	50	53	50	50	60
1	575	27.5	93,900	47	50	53	50	50	60	
1	600	30.0	102,400	47	50	53	50	50	60	
45 kW Order Two Each: EHA360-22.5 208/230V 99J28 + 99J28 460V 99J29 + 99J29 575V 99J30 + 99J30 76 lbs. (35 kg) (total weight)	①2	208	33.8	115,300	163	172	180	175	175	200
	①2	220	37.8	129,000	163	172	180	175	175	200
	①2	230	41.3	141,000	163	172	180	175	175	200
	①2	240	45.0	153,600	163	172	180	175	175	200
	①2	440	37.8	129,000	81	85	89	90	90	90
	①2	460	41.3	141,000	81	85	89	90	90	90
	①2	480	45.0	153,600	81	85	89	90	90	90
	①2	550	37.8	129,000	65	68	71	70	70	80
①2	575	41.3	141,000	65	68	71	70	70	80	
①2	600	45.0	153,600	65	68	71	70	70	80	
60 kW Order Two Each: EHA150-30 208/230V 99J07 + 99J07 460V 99J08 + 99J08 575V 99J09 + 99J09 76 lbs. (35 kg) (total weight)	①2	208	45.0	153,600	172	181	189	175	200	200
	①2	220	50.4	172,000	172	181	189	175	200	200
	①2	230	55.1	188,000	172	181	189	175	200	200
	①2	240	60.0	204,800	172	181	189	175	200	200
	①2	440	50.4	172,000	85	90	93	90	90	100
	①2	460	55.1	188,000	85	90	93	90	90	100
	①2	480	60.0	204,800	85	90	93	90	90	100
	①2	550	50.4	172,000	68	72	74	70	80	80
①2	575	55.1	188,000	68	72	74	70	80	80	
①2	600	60.0	204,800	68	72	74	70	80	80	
90 kW Order Two Each: EHA360-45 208/230V 99J31 + 99J31 460V 99J32 + 99J32 575V 99J33 + 99J33 84 lbs. (38 kg) (total weight)	①2	208	67.6	230,700	244	253	261	250	③300	③300
	①2	220	75.6	258,000	244	253	261	250	③300	③300
	①2	230	82.7	282,200	244	253	261	250	③300	③300
	①2	240	90.0	307,100	244	253	261	250	③300	③300
	①2	440	75.6	258,000	122	126	130	125	150	150
	①2	460	82.7	282,200	122	126	130	125	150	150
	①2	480	90.0	307,100	122	126	130	125	150	150
	①2	550	75.6	258,000	97	101	103	100	110	110
①2	575	82.7	282,200	97	101	103	100	110	110	
①2	600	90.0	307,100	97	101	103	100	110	110	

†Refer to National or Canadian Electrical Code manual to determine wire, fuse and disconnect size requirements. Use wires suitable for at least 167°F (75°C).

① May be used with two stage control.

② Electric Heat Control Module required on 45, 60 & 90 kW sizes only (module furnished with factory installed electric heaters). See Optional Electric Heat Accessories tables.

③ Factory installed circuit breaker not available.

NOTE — Fuse block must be ordered extra. Factory installed heaters will have the fuse block factory installed. Fuse block must be installed in field installed heaters. Also requires LTB2 Terminal Block. See Optional Electric Heat Accessories tables.

TABLE 8

LCA240H (R-410A)										
REQUIRES UNIT FUSE BLOCK, TERMINAL BLOCK AND ¹ HEATER CONTROL MODULE										
Electric Heat Model No. & Net Weight	No. of Steps	Volts Input	kW Input	Btuh Output	² Minimum Circuit Ampacity Total Unit + Electric Heat (with Power Exhaust Fans)			³ Maximum Overcurrent Protection Total Unit + Electric Heat (with Power Exhaust Fans)		
					5 hp (3.7 kW)	7.5 hp (5.6 kW)	10 hp (7.5 kW)	5 hp (3.7 kW)	7.5 hp (5.6 kW)	10 hp (7.5 kW)
15 kW Order One Each: EHA240-7.5 + EHA240S-7.5 208/230V 99J16 + 99J17 460V 99J18 + 99J19 575V 99J20 + 99J21 59 lbs. (27 kg) (total weight)	1	208	11.3	38,600						
	1	220	12.6	43,000						
	1	230	13.8	47,100	119	126	133	125	150	150
	1	240	15.0	51,200						
	1	440	12.6	43,000						
460V 99J18 + 99J19 575V 99J20 + 99J21 59 lbs. (27 kg) (total weight)	1	460	13.8	47,100	57	60	63	60	70	70
	1	480	15.0	51,200						
	1	550	12.6	43,000						
	1	575	13.8	47,100	45	48	50	50	50	60
	1	600	15.0	51,200						
30 kW Order One Each: EHA360-15 + EHA360S-15 208/230V 99J22 + 99J23 460V 99J24 + 99J25 575V 99J26 + 99J27 59 lbs. (27 kg) (total weight)	1	208	22.5	76,800						
	1	220	25.2	86,000						
	1	230	27.5	93,900	119	127	135	125	150	150
	1	240	30.0	102,400						
	1	440	25.2	86,000						
460V 99J24 + 99J25 575V 99J26 + 99J27 59 lbs. (27 kg) (total weight)	1	460	27.5	93,900	58	63	66	60	70	70
	1	480	30.0	102,400						
	1	550	25.2	86,000						
	1	575	27.5	93,900	47	50	53	50	50	60
	1	600	30.0	102,400						
45 kW Order Two Each: EHA360-22.5 208/230V 99J28 + 99J28 460V 99J29 + 99J29 575V 99J30 + 99J30 76 lbs. (35 kg) (total weight)	4	208	33.8	115,300						
	2	220	37.8	129,000						
	4	230	41.3	141,000	163	172	180	175	175	200
	2	240	45.0	153,600						
	4	440	37.8	129,000						
	2	460	41.3	141,000	81	85	89	90	90	90
	4	480	45.0	153,600						
	4	550	37.8	129,000						
	2	575	41.3	141,000	65	68	71	70	70	80
	2	600	45.0	153,600						
60 kW Order Two Each: EHA150-30 208/230V 99J07 + 99J07 460V 99J08 + 99J08 575V 99J09 + 99J09 76 lbs. (35 kg) (total weight)	4	208	45.0	153,600						
	2	220	50.4	172,000						
	4	230	55.1	188,000	172	181	189	175	200	200
	2	240	60.0	204,800						
	4	440	50.4	172,000						
	2	460	55.1	188,000	85	90	93	90	90	100
	4	480	60.0	204,800						
	4	550	50.4	172,000						
	2	575	55.1	188,000	68	72	74	70	80	80
	2	600	60.0	204,800						
90 kW Order Two Each: EHA360-45 208/230V 99J31 + 99J31 460V 99J32 + 99J32 575V 99J33 + 99J33 84 lbs. (38 kg) (total weight)	4	208	67.6	230,700						
	2	220	75.6	258,000						
	4	230	82.7	282,200	244	253	261	250	⁵ 300	⁵ 300
	2	240	90.0	307,100						
	4	440	75.6	258,000						
	2	460	82.7	282,200	122	126	130	125	150	150
	4	480	90.0	307,100						
	4	550	75.6	258,000						
	2	575	82.7	282,200	97	101	103	100	110	110
	2	600	90.0	307,100						

NOTE - Fuse block must be ordered extra. Factory installed heaters will have the fuse block factory installed. Fuse block must be installed in field installed heaters. Also requires LTB2 Terminal Block. See Optional Electric Heat Accessories tables.

¹ Electric Heat Control Module required on 45, 60 & 90 kW sizes only (module furnished with factory installed electric heaters). See Optional Electric Heat Accessories tables.

² Refer to National or Canadian Electrical Code manual to determine wire, fuse and disconnect size requirements. Use wires suitable for at least 167°F (75°C).

³ HACR type breaker or fuse.







































⁴ May be used with two stage control.

⁵ Factory installed circuit breaker not available.

TABLE 9

LCA300 - OPTIONAL ELECTRIC HEAT DATA

(Requires Unit Fuse Block, Terminal Block and  Heater Control Module)

Electric Heat Model No. & Net Weight	No. of Steps	Volts Input	kW Input	Btuh Output	†Total Unit + Electric Heat Minimum Circuit Ampacity (with Power Exhaust Fans)			Total Unit + Electric Heat Maximum Fuse Size (with Power Exhaust Fans)		
					5 hp (3.7 kW)	7.5 hp (5.6 kW)	10 hp (7.5 kW)	5 hp (3.7 kW)	7.5 hp (5.6 kW)	10 hp (7.5 kW)
15 kW	1	208	11.3	38,600	113	122	130	125	125	150
Order One Each:	1	220	12.6	43,000	113	122	130	125	125	150
EHA240-7.5 + EHA240S-7.5	1	230	13.8	47,100	113	122	130	125	125	150
208/230V	1	240	15.0	51,200	113	122	130	125	125	150
99J16 + 99J17	1	440	12.6	43,000	55	59	63	60	60	70
460V	1	460	13.8	47,100	55	59	63	60	60	70
99J18 + 99J19	1	480	15.0	51,200	55	59	63	60	60	70
575V	1	550	12.6	43,000	45	48	51	50	50	60
99J20 + 99J21	1	575	13.8	47,100	45	48	51	50	50	60
59 lbs. (27 kg) (total weight)	1	600	15.0	51,200	45	48	51	50	50	60
30 kW	1	208	22.5	76,800	118	127	135	125	150	150
Order One Each:	1	220	25.2	86,000	118	127	135	125	150	150
EHA360-15 + EHA360S-15	1	230	27.5	93,900	118	127	135	125	150	150
208/230V	1	240	30.0	102,400	118	127	135	125	150	150
99J22 + 99J23	1	440	25.2	86,000	58	63	66	60	70	70
460V	1	460	27.5	93,900	58	63	66	60	70	70
99J24 + 99J25	1	480	30.0	102,400	58	63	66	60	70	70
575V	1	550	25.2	86,000	47	50	53	50	50	60
99J26 + 99J27	1	575	27.5	93,900	47	50	53	50	50	60
59 lbs. (27 kg) (total weight)	1	600	30.0	102,400	47	50	53	50	50	60
45 kW	 2	208	33.8	115,300	163	172	180	175	175	200
Order Two Each:	 2	220	37.8	129,000	163	172	180	175	175	200
EHA360-22.5	 2	230	41.3	141,000	163	172	180	175	175	200
208/230V	 2	240	45.0	153,600	163	172	180	175	175	200
99J28 + 99J28	 2	440	37.8	129,000	81	85	89	90	90	90
460V	 2	460	41.3	141,000	81	85	89	90	90	90
99J29 + 99J29	 2	480	45.0	153,600	81	85	89	90	90	90
575V	 2	550	37.8	129,000	65	68	71	70	70	80
99J30 + 99J30	 2	575	41.3	141,000	65	68	71	70	70	80
76 lbs. (35 kg) (total weight)	 2	600	45.0	153,600	65	68	71	70	70	80
60 kW	 2	208	45.0	153,600	172	181	189	175	200	200
Order Two Each:	 2	220	50.4	172,000	172	181	189	175	200	200
EHA150-30	 2	230	55.1	188,000	172	181	189	175	200	200
208/230V	 2	240	60.0	204,800	172	181	189	175	200	200
99J07 + 99J07	 2	440	50.4	172,000	85	90	93	90	90	100
460V	 2	460	55.1	188,000	85	90	93	90	90	100
99J08 + 99J08	 2	480	60.0	204,800	85	90	93	90	90	100
575V	 2	550	50.4	172,000	68	72	74	70	80	80
99J09 + 99J09	 2	575	55.1	188,000	68	72	74	70	80	80
76 lbs. (35 kg) (total weight)	 2	600	60.0	204,800	68	72	74	70	80	80
90 kW	 2	208	67.6	230,700	244	253	261	250	 300	 300
Order Two Each:	 2	220	75.6	258,000	244	253	261	250	 300	 300
EHA360-45	 2	230	82.7	282,200	244	253	261	250	 300	 300
208/230V	 2	240	90.0	307,100	244	253	261	250	 300	 300
99J31 + 99J31	 2	440	75.6	258,000	122	126	130	125	150	150
460V	 2	460	82.7	282,200	122	126	130	125	150	150
99J32 + 99J32	 2	480	90.0	307,100	122	126	130	125	150	150
575V	 2	550	75.6	258,000	97	101	103	100	110	110
99J33 + 99J33	 2	575	82.7	282,200	97	101	103	100	110	110
84 lbs. (38 kg) (total weight)	 2	600	90.0	307,100	97	101	103	100	110	110

†Refer to National or Canadian Electrical Code manual to determine wire, fuse and disconnect size requirements. Use wires suitable for at least 167°F (75°C).

 May be used with two stage control.

 Electric Heat Control Module required on 45, 60 & 90 kW sizes only (module furnished with factory installed electric heaters). See Optional Electric Heat Accessories tables.

 Factory installed circuit breaker not available.

NOTE — Fuse block must be ordered extra. Factory installed heaters will have the fuse block factory installed. Fuse block must be installed in field installed heaters. Also requires LTB2 Terminal Block. See Optional Electric Heat Accessories tables.

E-Optional Electric Heat Components

Tables 4 through 9 show all possible LCA/LHA to EHA match-ups and electrical ratings.

EHA parts arrangement is shown in figures 28 and 29. All electric heat sections consist of electric heating elements exposed directly to the airstream. Two electric heat sections (first section and second section) are used in all 15kW through 90kW heaters. See figure 27. Multiple-stage elements are sequenced on and off in response to thermostat demand.

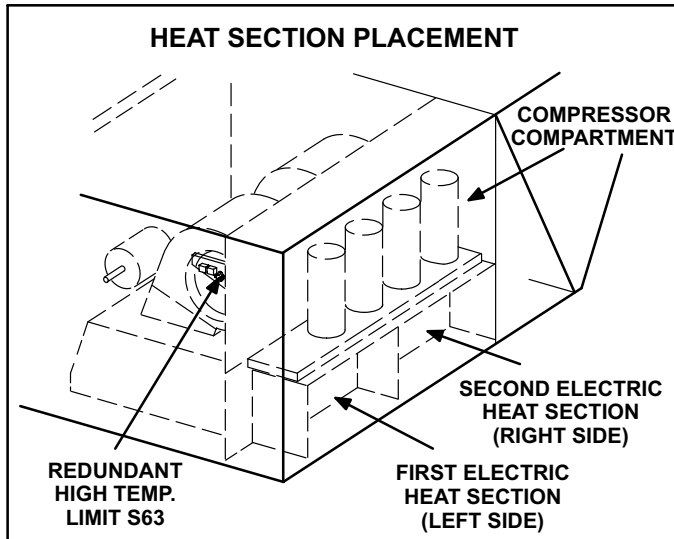

FIGURE 27

1-Main Control Box Components

A55, A60, K9, T2, and F4

The main control box (see figure 4) houses a few of the electric heat controls, such as: the main control module A55, second electric heat section control panel A60, electric heat control hat section for 45 - 90 kW (electric heat relay K9 and transformer T2), and unit fuse block F4. For a description of the components see section I-A.

2-Contactors K15, K16, K17 and K18

Contactors K15, K16, K17 and K18 are all three-pole double-break contactors located on the electric heat vestibule. K15 and K16 are located on the first electric heat section, while K17 and K18 are located on the second electric heat section. However, in the 15 and 30kW heaters, the first section houses all contactors and fuses. All contactors are equipped with a 24VAC coil. The coils in the K15 and K16 contactors are energized by the main panel A55, while the coil in the K17 and K18 contactors are energized by the electric heat 2 control panel A60. Contactors K15 and K17 energize the first stage heating elements, while K16 and K18 energize the second stage heating elements.

3-High Temperature Limits S15 and S107 (Primary)

S15 and S107 are SPST N.C. auto-reset thermostats located on the back panel of the electric heat section below the heating elements. S15 is the high temperature limit for the first electric heat section, while S107 is the high temperature limit for the second electric heat section. Both thermostats are identical and are wired in series with the first stage contactor coil. When either S15 or S107 opens, indicating a problem in the system, contactor K15 is de-energized. When K15 is de-energized, first stage and all subsequent stages of heat are de-energized. The thermostats used on EHA360-45-1 Y/G/J are factory set to open at $200^{\circ}\text{F} \pm 5^{\circ}\text{F}$ ($93.3^{\circ}\text{C} \pm 2.8^{\circ}\text{C}$) on a temperature rise and automatically reset at $160^{\circ}\text{F} \pm 6^{\circ}\text{F}$ ($71.1^{\circ}\text{C} \pm 3.3^{\circ}\text{C}$) on a temperature fall. All other electric heat section thermostats are factory set to open at $170^{\circ}\text{F} \pm 5^{\circ}\text{F}$ ($76.7^{\circ}\text{C} \pm 2.8^{\circ}\text{C}$) on a temperature rise and automatically reset at $130^{\circ}\text{F} \pm 6^{\circ}\text{F}$ ($54.4^{\circ}\text{C} \pm 3.3^{\circ}\text{C}$) on a temperature fall. The thermostats are not adjustable.

4-High Temperature Limit S63 (Redundant)

S63 is a SPST N.C. manual-reset thermostat located on the suction line bracket inside the blower compartment (see figure 27). S63 is a redundant temperature limit factory installed in all LCA / LHA units. Like the primary temperature limits, S63 is wired in series with the first stage contactor coil (K15). When S63 opens, all contactors (K15, K16, K17, K18) are de-energized. When the contactors are de-energized, first stage and all subsequent stages of heat are de-energized. The thermostat is factory set to open at $170^{\circ}\text{F} \pm 8^{\circ}\text{F}$ ($76.7^{\circ}\text{C} \pm 4.4^{\circ}\text{C}$) on a temperature rise and can be manually reset when the temperature falls below $160^{\circ}\text{F} \pm 6^{\circ}\text{F}$ ($71.1^{\circ}\text{C} \pm 3.3^{\circ}\text{C}$).

5-Terminal Strip TB3

Electric heat line voltage connections are made to terminal strip TB3 (or a fuse block on some models) located in the upper left corner of the electric heat vestibule.

6-Heating Elements HE1 through HE14

Heating elements are composed of helix wound bare nichrome wire exposed directly to the airstream. Three elements are connected in a three-phase arrangement. The elements in 208/230V units are connected in a "Delta" arrangement. Elements in 460 and 575V units are connected in "Wye" arrangement. Each stage is energized independently by the corresponding contactors located on the electric heat vestibule panel. Once energized, heat transfer is instantaneous. High temperature protection is provided by primary and redundant high temperature limits and overcurrent protection is provided by fuses.

7-Fuse F3

Fuse F3 are housed in a fuse block which holds three fuses. Each F3 fuse is connected in series with each leg of electric heat. Figure 29 and table 10 show the fuses used with each electric heat section. For simplicity, the service manual labels the fuses F3 - 1 through F3 - 8.

TABLE 10

LCA / LHA ELECTRIC HEAT SECTION FUSE RATING

EHA QUANTITY & SIZE	VOLTAGES	FUSE (3 each)							
		F3 - 1	F3 - 2	F3 - 3	F3 - 4	F3 - 5	F3 - 6	F3 - 7	F3 - 8
(1) EHA240-7.5 & (1) EHA240S-7.5 (15 kW Total)	208/230V	50 Amp 250V	---	---	---	---	---	---	---
	460V	25 Amp 600V	---	---	---	---	---	---	---
	575V	20 Amp 600V	---	---	---	---	---	---	---
(1) EHA360-15 & (1) EHA360S-15 (30 kW Total) or (1) EHA156-15 & (1) EHA156S-15	208/230V	60 Amp 250V	60 Amp 250V	---	---	---	---	---	---
	460V	50 Amp 600V	---	---	---	---	---	---	---
	575V	40 Amp 600V	---	---	---	---	---	---	---
(2) EHA360-22.5 (45 kW Total) or (2) EHA156-22.5	208/230V	50 Amp 250V	---	---	25 Amp 250V	50 Amp 250V	---	---	25 Amp 250V
	460V	25 Amp 600V	---	---	15 Amp 600V	25 Amp 600V	---	---	15 Amp 600V
	575V	20 Amp 600V	---	---	10 Amp 600V	20 Amp 600V	---	---	10 Amp 600V
(2) EHA150-30 (60 kW Total) or (2) EHA156-30	208/230V	50 Amp 250V	---	---	50 Amp 250V	50 Amp 250V	---	---	50 Amp 250V
	460V	25 Amp 600V	---	---	25 Amp 600V	25 Amp 600V	---	---	25 Amp 600V
	575V	20 Amp 600V	---	---	20 Amp 600V	20 Amp 600V	---	---	20 Amp 600V
(2) EHA360-45 (90 kW Total)	208/230V	50 Amp 250V	---	60 Amp 250V	60 Amp 250V	50 Amp 250V	---	60 Amp 250V	60 Amp 250V
	460V	25 Amp 600V	---	---	50 Amp 600V	25 Amp 600V	---	---	50 Amp 600V
	575V	20 Amp 600V	---	---	40 Amp 600V	20 Amp 600V	---	---	40 Amp 600V

EHA 15, 30, 45, 60, and 90 KW
ELECTRIC HEAT SECTION PARTS ARRANGEMENT

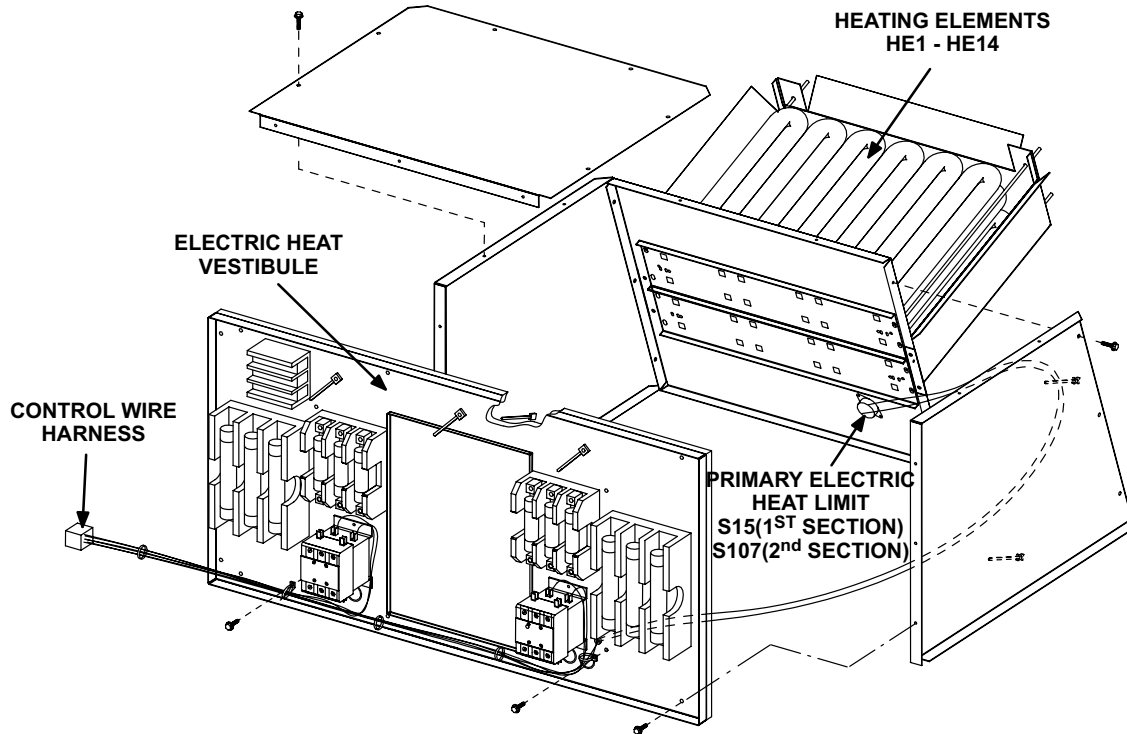
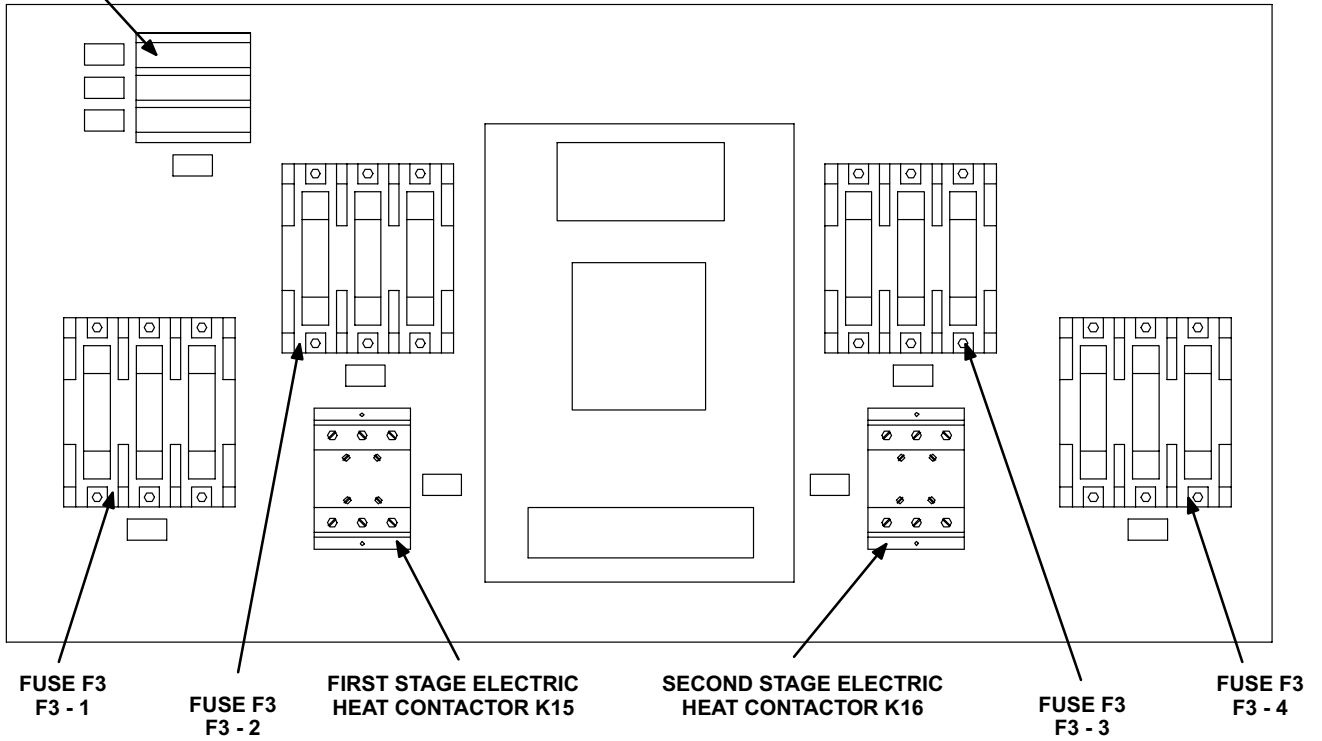

FIGURE 28

ELECTRIC HEAT VESTIBULE PARTS ARRANGEMENT

TERMINAL STRIP
(TB3)

FIRST HEAT SECTION (LEFT SIDE)



TERMINAL STRIP
(TB3)

SECOND HEAT SECTION (RIGHT SIDE)

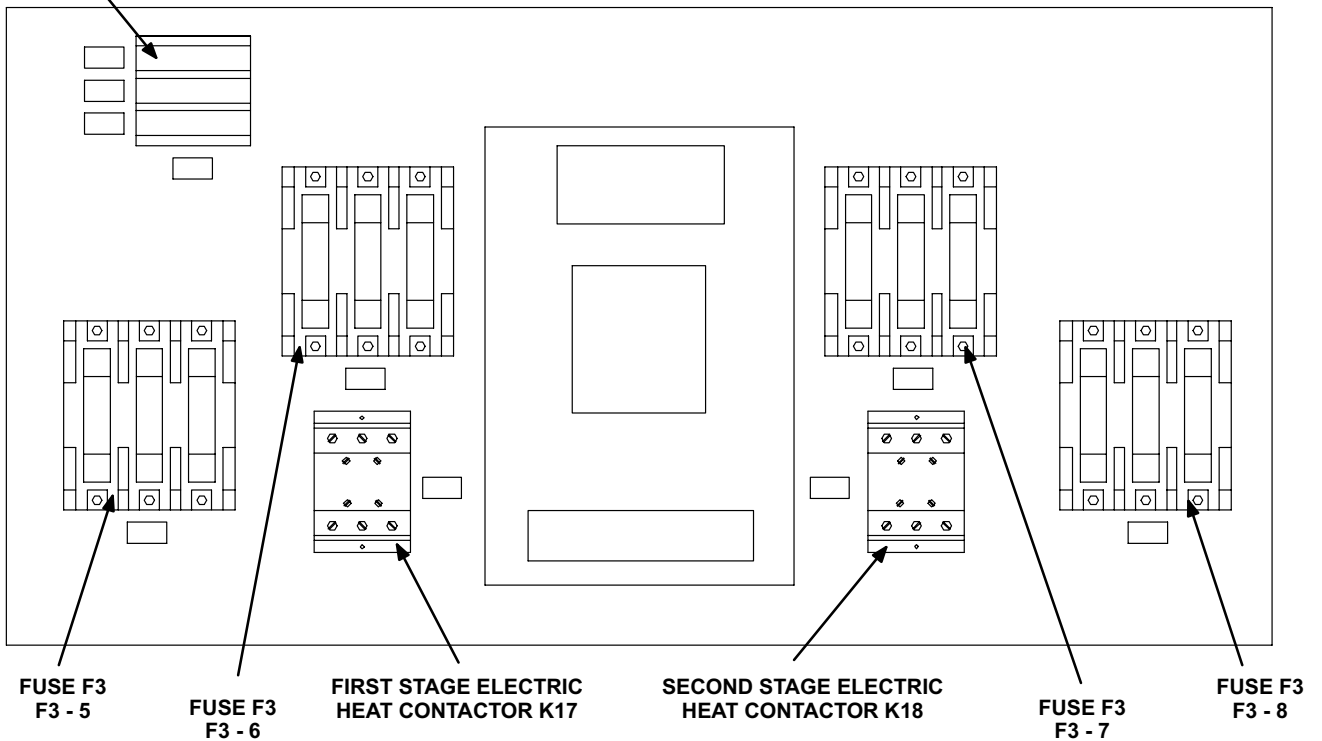

FIGURE 29

II-PLACEMENT AND INSTALLATION

Make sure the unit is installed in accordance with the installation instructions and all applicable codes. See accessories section for conditions requiring use of the optional roof mounting frame (LARMF18/36 or LARMFH18/24).

III-CHARGING

⚠ WARNING

Refrigerant can be harmful if it is inhaled. Refrigerant must be used and recovered responsibly.

Failure to follow this warning may result in personal injury or death.

⚠ IMPORTANT

Units equipped with Humiditrol system **MUST** be charged in standard cooling mode.

A-Refrigerant Charge and Check

WARNING-Do not exceed nameplate charge under any condition.

This unit is factory charged and should require no further adjustment. If the system requires charge, *reclaim the charge, evacuate the system, and add required nameplate charge.*

NOTE - System charging is not recommended below 60°F (15°C). In temperatures below 60°F (15°C), the charge must be weighed into the system.

If weighing facilities are not available, or to check the charge, use the following procedure:

- 1- Attach gauge manifolds and operate unit in cooling mode until system stabilizes (approximately five minutes). Make sure all outdoor air dampers are closed.
- 2- Check each system separately with all stages operating.
- 3- Use a thermometer to accurately measure the outdoor ambient temperature.
- 4- Apply the outdoor temperature to tables 11 through 19 (tables 20, 21, 22 and 23 are for humiditrol units) and through to determine normal operating pressures.
- 5- Compare the normal operating pressures to the pressures obtained from the gauges. Minor variations in these pressures may be expected due to differences in installations. Significant differences could mean that the system is not properly charged or that a problem exists with some component in the system. **Correct any system problems before proceeding.**
- 6- If discharge pressure is high, remove refrigerant from the system. If discharge pressure is low, add refrigerant to the system.
 - Add or remove charge in increments.
 - Allow the system to stabilize each time refrigerant is added or removed.
- 7- Use the following approach method along with the normal operating pressures to confirm readings.

**TABLE 11
LGA/LCA156H
NORMAL OPERATING PRESSURES**

Outdoor Coil Entering Air Temp.	CIRCUIT 1		CIRCUIT 2		CIRCUIT 3	
	Dis. ± 10 psig	Suct. ± 5 psig	Dis. ± 10 psig	Suct. ± 5 psig	Dis. ± 10 psig	Suct. ± 5 psig
65°F	OUTDOOR FAN CYCLES					
75°F	171	77	168	81	180	82
85°F	196	78	194	82	206	83
95°F	228	79	227	84	237	84
105°F	262	80	260	85	272	85
115°F	301	82	299	86	309	86

**TABLE 12
LGA/LCA180S NORMAL OPERATING PRESSURES**

Outdoor Coil Entering Air Temp.	CIRCUIT 1		CIRCUIT 2		CIRCUIT 3	
	Dis. ± 10 psig	Suct. ± 5 psig	Dis. ± 10 psig	Suct. ± 5 psig	Dis. ± 10 psig	Suct. ± 5 psig
65°F	191	74	193	76	200	75
75°F	217	76	222	77	225	76
85°F	245	78	252	79	250	78
95°F	279	80	288	81	290	79
105°F	312	82	324	83	332	81
115°F	354	85	368	85	372	83

**TABLE 13
LCA/LGA180H NORMAL OPERATING PRESSURES**

Outdoor Coil Entering Air Temp.	CIRCUIT 1		CIRCUIT 2		CIRCUIT 3	
	Dis. ± 10 psig	Suct. ± 5 psig	Dis. ± 10 psig	Suct. ± 5 psig	Dis. ± 10 psig	Suct. ± 5 psig
65°F	163	75	161	77	165	73
75°F	186	77	187	79	190	74
85°F	213	78	215	80	218	76
95°F	244	80	246	81	247	78
105°F	280	82	282	83	285	80
115°F	318	85	323	85	325	82

**TABLE 14
LCA/LGA210S NORMAL OPERATING PRESSURES**

Outdoor Coil Entering Air Temp.	CIRCUIT 1		CIRCUIT 2		CIRCUIT 3		CIRCUIT 4	
	Dis. ± 10 psig	Suct. ± 5 psig	Dis. ± 10 psig	Suct. ± 5 psig	Dis. ± 10 psig	Suct. ± 5 psig	Dis. ± 10 psig	Suct. ± 5 psig
65°F	198	77	192	78	199	77	195	69
75°F	226	78	218	79	227	78	225	71
85°F	257	80	248	81	260	80	258	74
95°F	290	82	280	83	294	82	295	76
105°F	328	84	318	85	335	83	335	79
115°F	367	86	357	86	380	85	380	82

**TABLE 15
LCA/LGA210H NORMAL OPERATING PRESSURES**

Outdoor Coil Entering Air Temp.	CIRCUIT 1		CIRCUIT 2		CIRCUIT 3		CIRCUIT 4	
	Dis. ± 10 psig	Suct. ± 5 psig	Dis. ± 10 psig	Suct. ± 5 psig	Dis. ± 10 psig	Suct. ± 5 psig	Dis. ± 10 psig	Suct. ± 5 psig
65°F	170	80	175	82	168	82	165	80
75°F	195	82	200	83	192	83	190	81
85°F	223	83	228	85	222	84	220	83
95°F	255	85	260	86	257	85	254	85
105°F	292	86	297	88	290	87	290	86
115°F	324	88	334	89	334	88	330	88

TABLE 16
LGA/LCA240S NORMAL OPERATING PRESSURES

Outdoor Coil Entering Air Temp	CIRCUIT 1		CIRCUIT 2		CIRCUIT 3		CIRCUIT 4	
	Dis. ±10 psig	Suc. ±5 psig	Dis. ±10 psig	Suc. ±5 psig	Dis. ±10 psig	Suc. ±5 psig	Dis. ±10 psig	Suc. ±5 psig
65°F	180	69	175	72	186	75	178	72
75°F	205	71	200	73	213	76	204	73
85°F	232	73	230	75	242	78	236	74
95°F	265	75	260	77	276	80	267	76
105°F	300	77	300	79	316	82	305	78
115°F	343	79	340	81	360	84	346	80

TABLE 17
LGA/LCA240H NORMAL OPERATING PRESSURES

Outdoor Coil Entering Air Temp.	CIRCUIT 1		CIRCUIT 2		CIRCUIT 3		CIRCUIT 4	
	Dis. ± 10 psig	Suct. ± 5 psig	Dis. ± 10 psig	Suct. ± 5 psig	Dis. ± 10 psig	Suct. ± 5 psig	Dis. ± 10 psig	Suct. ± 5 psig
65°F	177	75	170	76	180	78	178	77
75°F	202	76	195	77	208	79	202	78
85°F	232	77	225	78	240	80	232	80
95°F	265	78	258	79	274	81	265	81
105°F	300	80	295	81	314	82	303	83
115°F	340	82	332	82	353	83	340	84

TABLE 18
LGA/LCA240H NORMAL OPERATING PRESSURES R410A

Outdoor Coil Entering Air Temp	CIRCUIT 1		CIRCUIT 2		CIRCUIT 3		CIRCUIT 4	
	Dis. ±10 psig	Suc. ±5 psig	Dis. ±10 psig	Suc. ±5 psig	Dis. ±10 psig	Suc. ±5 psig	Dis. ±10 psig	Suc. ±5 psig
65°F	278	131	281	141	292	141	283	141
75°F	312	133	314	142	329	143	317	143
85°F	356	137	358	145	373	144	359	145
95°F	404	141	407	147	422	147	408	148
105°F	454	144	458	149	473	149	458	150
115°F	509	146	514	153	527	151	512	153

TABLE 19
LGA/LCA300S NORMAL OPERATING PRESSURES

Outdoor Coil Entering Air Temp.	CIRCUIT 1		CIRCUIT 2		CIRCUIT 3		CIRCUIT 4	
	Dis. ± 10 psig	Suct. ± 5 psig	Dis. ± 10 psig	Suct. ± 5 psig	Dis. ± 10 psig	Suct. ± 5 psig	Dis. ± 10 psig	Suct. ± 5 psig
65°F	184	74	183	76	191	77	188	76
75°F	213	76	210	77	220	77	216	77
85°F	244	78	242	79	252	79	247	79
95°F	282	79	285	80	295	80	278	80
105°F	313	80	317	82	324	81	325	82
115°F	357	82	361	83	368	83	372	84

HUMIDITROL UNITS

TABLE 20
LGA/LCA180H NORMAL OPERATING PRESSURES

Outdoor Coil Entering Air Temp	CIRCUIT 1		CIRCUIT 2		CIRCUIT 3	
	Dis. ±10 psig	Suct. ±5 psig	Dis. ±10 psig	Suc. ±5 psig	Dis. ±10 psig	Suc. ±5 psig
65°F	166	75	165	77	165	73
75°F	191	77	190	79	190	74
85°F	218	78	217	80	218	76
95°F	249	80	248	81	247	78
105°F	283	82	283	83	285	80
115°F	319	85	321	85	325	82

TABLE 21
LGA/LCA210H NORMAL OPERATING PRESSURES

Outdoor Coil Entering Air Temp	CIRCUIT 1		CIRCUIT 2		CIRCUIT 3		CIRCUIT 4	
	Dis ±10 psig	Suc ±5 psig	Dis ±10 psig	Suc ±5 psig	Dis ±10 psig	Suc ±5 psig	Dis ±10 psig	Suc ±5 psig
65°F	177	80	169	82	168	82	165	80
75°F	205	82	195	83	192	83	190	81
85°F	235	83	224	85	222	84	220	83
95°F	266	85	255	86	257	85	254	85
105°F	302	86	290	88	290	87	290	86
115°F	338	88	327	89	334	88	330	88

TABLE 22
LGA/LCA240H NORMAL OPERATING PRESSURES

Outdoor Coil Entering Air Temp	CIRCUIT 1		CIRCUIT 2		CIRCUIT 3		CIRCUIT 4	
	Dis ±10 psig	Suc ±5 psig	Dis ±10 psig	Suc ±5 psig	Dis ±10 psig	Suc ±5 psig	Dis ±10 psig	Suc ±5 psig
65°F	182	75	180	76	180	78	178	77
75°F	210	76	204	77	208	79	202	78
85°F	235	77	232	78	240	80	232	80
95°F	272	78	262	79	274	81	265	81
105°F	309	80	304	81	314	82	303	83
115°F	347	82	345	82	353	83	340	84

TABLE 23
LGA/LCA240H NORMAL OPERATING PRESSURES R410A

Outdoor Coil Entering Air Temp	CIRCUIT 1		CIRCUIT 2		CIRCUIT 3		CIRCUIT 4	
	Dis. ±10 psig	Suc. ±5 psig	Dis. ±10 psig	Suc. ±5 psig	Dis. ±10 psig	Suc. ±5 psig	Dis. ±10 psig	Suc. ±5 psig
65°F	283	131	286	141	292	141	283	141
75°F	317	133	319	142	329	143	317	143
85°F	361	137	363	145	373	144	359	145
95°F	409	141	412	147	422	147	408	148
105°F	459	144	463	149	473	149	458	150
115°F	514	146	519	153	527	151	512	153

B-Charge Verification - Approach Method

8- Using the same thermometer, compare liquid temperature to outdoor ambient temperature.

Approach Temperature = Liquid temperature minus ambient temperature.

9- Approach temperature should match values in tables 24, 25 and 26. An approach temperature greater than value shown indicates an undercharge. An approach temperature less than value shown indicates an overcharge.

10-Do not use the approach method if system pressures do not match pressures in tables 11 through 19 (or tables 20, 21, 22 and 23 for Humidtrol units). The approach method is not valid for grossly over or undercharged systems.

**TABLE 24
APPROACH TEMPERATURES**

L Series Unit	Liquid Temp. Minus Ambient Temp.			
	1st Stage	2nd Stage	3rd Stage	4th Stage
156H	8°F ± 1 (4.4°C ± 0.5)	8°F ± 1 (4.4°C ± 0.5)	9°F ± 1 (5°C ± 0.5)	NA
180S	7°F ± 1 (3.8°C ± 0.5)	7°F ± 1 (3.8°C ± 0.5)	8°F ± 1 (4.4°C ± 0.5)	NA
180H	10°F ± 1 (5.6°C ± 0.5)	10°F ± 1 (5.6°C ± 0.5)	8°F ± 1 (4.4°C ± 0.5)	NA
210S	8°F ± 1 (4.4°C ± 0.5)	8°F ± 1 (4.4°C ± 0.5)	7°F ± 1 (3.8°C ± 0.5)	9°F ± 1 (5°C ± 0.5)
210H	8°F ± 1 (4.4°C ± 0.5)	8°F ± 1 (4.4°C ± 0.5)	7°F ± 1 (3.8°C ± 0.5)	8°F ± 1 (4.4°C ± 0.5)
240S	9°F ± 1 (5°C ± 0.5)	12°F ± 1 (6.7°C ± 0.5)	11°F ± 1 (6.1°C ± 0.5)	10°F ± 1 (5.6°C ± 0.5)
240H	10°F ± 1 (5.6°C ± 0.5)	9°F ± 1 (5°C ± 0.5)	10°F ± 1 (5.6°C ± 0.5)	11°F ± 1 (6.1°C ± 0.5)
240H R410A	8°F ± 1 (4.4°C ± 1)	8°F ± 1 (4.4°C ± 1)	11°F ± 1 (6.1°C ± 1)	9°F ± 1 (5.0°C ± 1)
300S	11°F ± 1 (6.1°C ± 0.5)	11°F ± 1 (6.1°C ± 0.5)	11°F ± 1 (6.1°C ± 0.5)	11°F ± 1 (6.1°C ± 0.5)

**TABLE 25
APPROACH TEMPERATURES HUMIDITROL UNITS**

UNIT	Liquid Temp. Minus Ambient Temp.			
	1st Stage	2nd Stage	3rd Stage	4th Stage
180H	5°F±1 (2.7°C±0.5)	4°F±1 (2.2°C±0.5)	8°F±1 (4.4°C±0.5)	NA
210H	6°F±1 (3.3°C±0.5)	5°F±1 (2.7°C±0.5)	6°F±1 (3.3°C±0.5)	8°F±1 (4.4°C±0.5)
240H	5°F±1 (2.7°C±0.5)	4°F±1 (2.2°C±0.5)	10°F±1 (5.6°C±0.5)	11°F±1 (6.1°C±0.5)
240H R410A	6°F±1 (3.3°C±0.5)	6°F±1 (3.3°C±0.5)	11°F±1 (6.1°C±0.5)	9°F±1 (5.0°C±0.5)

**TABLE 26
LHA UNITS**

APPROACH TEMPERATURE		
UNIT	LIQUID TEMP. MINUS AMBIENT TEMP.	
	1ST STAGE	2ND STAGE
LHA180	10°F ± 1 (5.6°C ± 0.5)	11°F ± 1 (6.1 °C ± 0.5)
LHA240	11°F ± 1 (6.1 °C ± 0.5)	11°F ± 1 (6.1 °C ± 0.5)

IV-STARTUP - OPERATION

Refer to startup directions and refer closely to the unit wiring diagram when servicing. See unit nameplate for minimum circuit ampacity and maximum fuse size.

A-Preliminary and Seasonal Checks

- 1- Make sure the unit is installed in accordance with the installation instructions and applicable codes.
- 2- Inspect all electrical wiring, both field and factory installed for loose connections. Tighten as required. Refer to unit diagram located on inside of unit control box cover.
- 3- Check to ensure that refrigerant lines are in good condition and do not rub against the cabinet or other refrigerant lines.
- 4- Check voltage at the disconnect switch. Voltage must be within the range listed on the nameplate. If not, consult the power company and have the voltage corrected before starting the unit.
- 5- Recheck voltage and amp draw with unit running. If voltage is not within range listed on unit nameplate, stop unit and consult power company. Refer to unit nameplate for maximum rated load amps.
- 6- Inspect and adjust blower belt (see section on Blower Compartment - Blower Belt Adjustment).

B-Cooling Startup

NOTE-The following is a generalized procedure and does not apply to all thermostat control systems. Electronic and ramping thermostat control systems may operate differently. Refer to the operation sequence section of this manual for more information.

⚠ WARNING

Crankcase heaters must be energized for 24 hours before attempting to start compressors. Set thermostat so there is no compressor demand before closing disconnect switch. Attempting to start compressors during the 24-hour warm-up period could result in damaged or failed compressors.

- 1- Set fan switch to AUTO or ON and move the system selection switch to COOL. Adjust the thermostat to a setting far enough below room temperature to bring on all compressors. Compressors will start and cycle on demand from the thermostat (allowing for unit and thermostat time delays).
- 2- Each circuit is charged with R-22 refrigerant. See unit rating plate for correct charge amount.
- 3- Refer to Cooling System Service Checks and Charging sections for proper method of checking and charging the system.

C-Heating Startup

- 1 Set the fan switch to AUTO or ON and move the system selection switch to HEAT. Adjust thermostat setting above room temperature.
- 2 The indoor blower, first stage gas (LGA only), all compressors (LHA only), and first stage electric heat (LCA only) immediately start.
- 3 Additional stages are controlled by the indoor thermostat. An increased heating demand (W2) in the LHA units will bring on the electric heat if so equipped.

D-Safety or Emergency Shutdown

Turn off power to the unit.

V- SYSTEMS SERVICE CHECKS

A-LGA Heating System Service Checks

All LGA units are A.G.A and C.G.A. design certified without modification.

Before checking piping, check with gas company or authorities having jurisdiction for local code requirements. Refer to the LGA Installation, Operation and Maintenance instruction for more information.

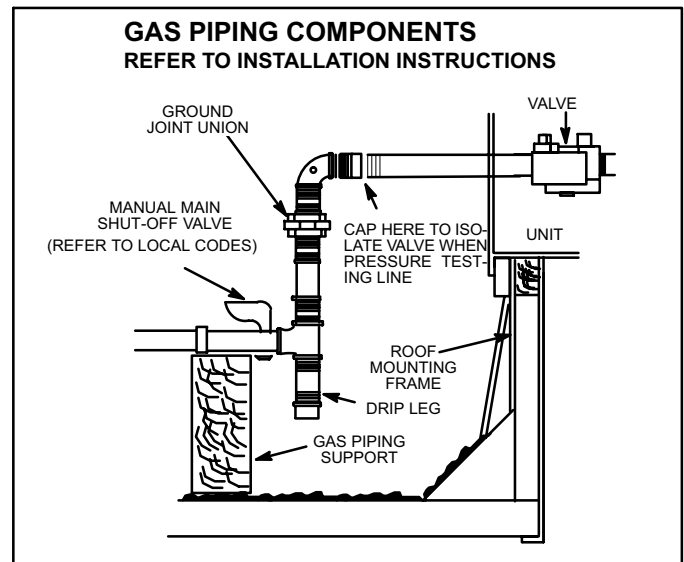

FIGURE 30

1-Gas Piping

Gas supply piping must not allow more than 0.5"W.C. (124.3 Pa) drop in pressure between the gas meter and the unit. Supply gas pipe must not be smaller than the unit gas connection. Refer to installation instructions for details.

2-Testing Gas Piping

NOTE-In case emergency shutdown is required, turn off the main manual shut-off valve and disconnect the main power to the unit. These controls should be properly labeled by the installer.

When pressure testing gas lines, the gas valve must be disconnected and isolated. Gas valves can be damaged if subjected to more than 0.5 psig [14"W.C. (3481 Pa)]. See figure 30.

When checking piping connection for gas leaks, use the preferred means. Common kitchen detergents can cause harmful corrosion on various metals used in gas piping. The use of specialty Gas Leak Detector is strongly recommended. It is available through Lennox under part number 31B2001. See CORP 8411-L10, for further details.

Do not use matches, candles, flame or any other source of ignition to check for gas leaks.

3-Testing Gas Supply Pressure

When testing gas supply pressure, connect test gauge to the inlet pressure tap on the gas valve. Test supply gas pressure with unit firing at maximum rate (both stages energized). Make sure the reading falls within the range of the following values. Low pressure may result in erratic operation or "underfire." High pressure can result in permanent damage to the gas valve or "overfire." For natural gas units, operating pressure at the unit gas connection must be between 4.7"W.C. and 10.5"W.C. (1168 Pa and 2610 Pa). For L.P. gas units, operating pressure at the unit gas connection must be between 10.8"W.C. and 13.5"W.C. (2685.3 Pa and 3356.7 Pa).

On multiple unit installations, each unit should be checked separately while operating at maximum rate, beginning with the one closest to the supply gas main and progressing to the one furthest from the main. Multiple units should also be tested with and without the other units operating. Supply pressure must fall within the range listed in the previous paragraph.

4-Check and Adjust Manifold Pressure

After line pressure has been checked and adjusted, check manifold pressure. Move test gauge to the outlet pressure tap located on unit gas valve GV1. See figure 24 for location of pressure tap on the gas valve.

The manifold pressure is factory set and should not require adjustment. If manifold pressure is incorrect and no other source of improper manifold pressure can be found, the valve must be replaced. See gas valve information in Gas Heat Component section and figure 24 for location of gas valve (manifold pressure) adjustment screw.

All gas valves are factory regulated. The gas valve should completely and immediately cycle off in the event of gas or power failure. The manual shut-off knob can be used to immediately shut off gas supply.

⚠ CAUTION

For safety, connect a shut-off valve between the manometer and the gas tap to permit shut off of gas pressure to the manometer.

Manifold Adjustment Procedure

- 1- Connect test gauge to the outlet pressure tap on the gas valve. Start the unit (call for second stage heat) and allow five minutes for the unit to reach steady state.
- 2- While waiting for the unit to stabilize, notice the flame. The flame should be stable without flashback and should not lift from the burner heads. Natural gas should burn basically blue with some clear streaks. L.P. gas should burn mostly blue with some clear yellow streaks.
- 3- After allowing the unit to stabilize for five minutes, record the manifold pressure and compare to the values given for gas supply pressure (above).

⚠ CAUTION

Disconnect heating demand as soon as an accurate reading has been obtained.

5-Proper Gas Flow

To check for proper gas flow to burners, determine Btuh input from unit rating plate or the gas heating capacity tables on page 4. Divide this input rating by the Btuh per cubic foot of available gas. Result is the number of cubic feet per hour required. Determine the flow of gas through gas meter for two minutes and multiply by 30 to get hourly flow of gas to the burners.

NOTE - To obtain accurate reading, shut off all other gas appliances connected to meter.

6-High Altitude Derate

Natural gas units may be installed at altitudes up to 2000 feet (610m) above sea level without any modification. At altitudes above 2000 feet (610 m), units must be derated to match gas manifold pressures shown in the following table.

NOTE-This is the only permissible derate for these units.

TABLE 27

Altitude - ft. (m)	Gas Manifold Pressure - in. w.g. (kPa)
2001 - 3000 (610 - 915)	3.6 (0.90)
3001 - 4000 (915 - 1220)	3.5 (0.87)
4001 - 5000 (1220 - 1525)	3.4 (0.85)
5001 - 6000 (1525 - 1830)	3.3 (0.82)
6001 - 7000 (1830 - 2135)	3.2 (0.80)
7001 - 8000 (2135 - 2440)	3.1 (0.77)

Derate Procedure:

- 1- Check manifold pressure at the gas valve pressure tap with unit operating at high fire (second stage).
- 2- To reduce maximum input, turn regulator adjusting screw (figure 24) counterclockwise.
- 3- Re-check manifold pressure.

7-Inshot Burner

Burners are factory set for maximum air and cannot be adjusted. Always operate unit with access panel in place. A peep hole is furnished in the heating access panel for flame viewing. Natural gas should burn basically blue with some clear streaks. L.P. gas should burn mostly blue with some clear yellow streaks.

Figure 31 shows how to remove burner assembly.

- 1- Turn off power to unit and shut off gas supply.
- 2- Remove screws holding the burner support cap.
- 3- Slide each burner off its orifice.
- 4- Clean and reassemble (reverse steps 1-3).
- 5- Be sure to secure all wires and check plumbing.
- 6- Turn on power to unit. Follow lighting instructions attached to unit and operate unit in heating mode. Check burner flames. They should be blue with yellow streaks.

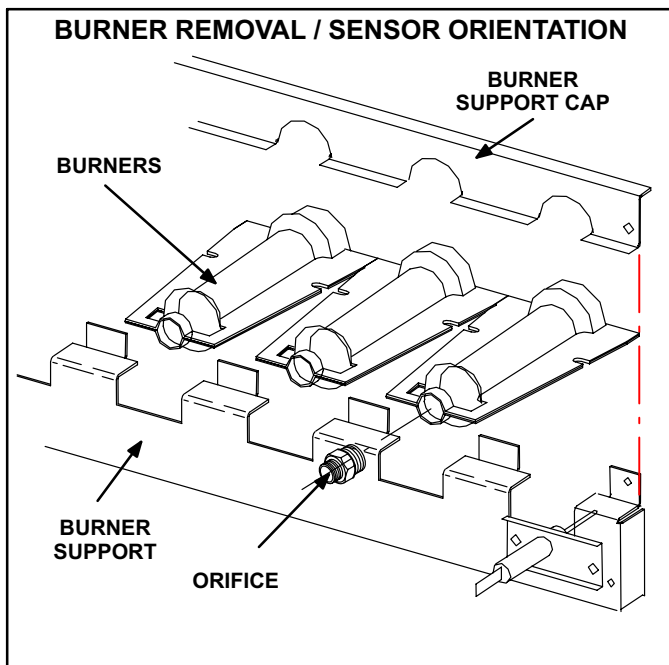

FIGURE 31

8-Heat Exchanger

To Access or Remove Heat Exchanger From Unit:

- 1- Turn off gas and electric power.
- 2- Remove access panel(s) and unit center mullion.
- 3- Remove gas valve, manifold assembly and burners.
- 4- Remove combustion air blower and flue box. Pay careful attention to the order in which gaskets and orifice are removed.
- 5- Support heat exchanger (to prevent it from falling when final screws are removed.)
- 6- Remove screws supporting heat exchanger.
- 7- To install heat exchanger, reverse procedure. Be sure to secure all wires and check plumbing and burner plate for airtight seal. Screws must be torqued to 35 in.-lbs. (155.7 N) to ensure proper operation.

9-Spark Electrode Gap

The spark electrode assembly can be removed for inspection by removing two screws securing the electrode assembly and sliding it out of unit.

For proper unit operation, electrodes must be positioned and gapped correctly.

Spark gap may be checked with appropriately sized twist drills or feeler gauges. Disconnect power to the unit and remove electrode assembly. The gap should be between $0.125'' \pm 0.015''$ (3.2 mm \pm .4 mm). See figure 25.

10-Flame Sensing

Flame current is an electrical current which passes from the ignition control through the sensor electrode during unit operation. The current passes from the sensor through the flame to the ground electrode (located on the flame electrode) to complete a safety circuit. The electrodes should be located so the tips are at least $1/2''$ (12.7 mm) inside the flame envelope. Do not bend electrodes. To measure flame current, follow the procedure below:

TABLE 28

Manufacturer	Nominal Signal Microamps	Drop Out
RAM	1.7-3.6	0.5
JOHNSON	0.5-1.0	.09
FENWALL	1.7-3.6	0.7

NOTE-Electrodes are not field adjustable. Any alterations to the electrode may create a hazardous condition that can cause property or personal injury.

- 1- Disconnect power to unit.
- 2- Remove lead from sensing electrode and install a 0-50DC microamp meter in series between the sensing electrode and the sensing lead.
- 3- Reconnect power and adjust thermostat for heating demand.
- 4- When flame is established, compare reading to table 28. Do not bend electrodes.
- 5- Disconnect power to unit before disconnecting meter. Make sure sensor wire is securely reconnected before reconnecting power to unit.

NOTE-If the meter scale reads 0, the leads are reversed. Disconnect power and reconnect leads for proper polarity.

11-Combustion Air Blower

The combustion air blower is factory set and is not field adjustable. However, operation should be monitored to ensure proper operation. The combustion air blower is used to draw fresh air into the combustion chamber while simultaneously expelling exhaust gases. The blower operates throughout the heating cycle.

On a heating demand, the ignition control is energized by the main control module A55. The ignition control then allows 30 to 40 seconds for the combustion air blower to vent exhaust gases from the burners. When the combustion air blower is purging the exhaust gases, the combustion air prove switch is closing proving that the combustion air blower is operating before allowing the ignition control to energize. When the combustion air prove switch is closed and the delay is over, the ignition control activates the first stage operator of the gas valve (low fire), the spark and the flame sensing electrode. Sparking stops immediately after flame is sensed.

B-Cooling System Service Checks

All models are factory charged and require no further adjustment; however, charge should be checked periodically using the approach method. The approach method compares actual liquid temperature with the outdoor ambient temperature.

1-Gauge Manifold Attachment

Service gauge ports are identified in figures 11, 12 and 13 on pages 23, 24, and 25 respectively. Attach high pressure line to discharge line schrader port and the low pressure line to the suction line schrader port.

NOTE-When unit is properly charged discharge line pressures should approximate those in tables 11 through 22.

VI-MAINTENANCE

NOTE - TURN OFF POWER TO UNIT BEFORE CLEANING OR PERFORMING ANY SERVICE OPERATION TO THIS UNIT.

A-Filters

All models are equipped with six 24" x 24" x 2" (610mm x 610mm x 51mm) pleated throw-away type filters. Filters may be accessed through the economizer / filter access door (left of the blower door). All filters are removed by pulling on the pull tab, located on the bottom of each row of filters. Filters should be checked monthly (or more frequently in severe use) and cleaned or replaced regularly. Take note of the "AIR FLOW DIRECTION" marking on the filter frame when re-installing.

NOTE-Filters must be U.L.C. certified or equivalent for use in Canada.

B-Lubrication

All motors and blower wheels used in LGA / LCA / LHA units are prelubricated; no further lubrication is required.

C-Supply Air Blower Wheel

Annually inspect supply air blower wheel for accumulated dirt or dust. Turn off power before attempting to remove access panel or to clean blower wheel.

D-Evaporator Coil

Inspect and clean coil at beginning of each season. Clean using mild detergent or commercial coil cleanser. Check condensate drain pan and line, if necessary. Flush coil and condensate drain with water taking care not to get insulation, filters and return air ducts wet. Check connecting lines and coil for evidence of oil and refrigerant leaks.

E-Condenser Coil

Clean condenser coil annually with detergent or commercial coil cleaner and inspect monthly during the cooling season. Check connecting lines and coil for evidence of oil and refrigerant leaks.

NOTE-If owner complains of insufficient cooling, the unit should be gauged and refrigerant charge checked. Refer to Gauge Manifold Attachment and Charging sections in this manual.

F-Electrical

- 1- Check all wiring for loose connections.
- 2- Check for correct voltage at unit (unit operating).
- 3- Check amp-draw on both condenser fan motor and blower motor.

Fan Motor Rating Plate ____ Actual _____

Indoor Blower Motor Rating Plate ____ Actual _____

VII-ACCESSORIES

The accessories section describes the application of most of the optional accessories which can be factory or field installed to either the LGA / LCA / LHA units.

A-LARMF18/36-14, 24 or

LARMFH18/24-26, 37 Mounting Frames

When installing either the LGA / LCA / LHA units on a combustible surface for downflow discharge applications, the Lennox LARMF18/36 14-inch or 24-inch (356 mm or 610mm) height roof mounting frame is used. For horizontal discharge applications, use LARMFH18/24 26-inch or 37-inch (660mm or 940mm) height roof mounting frame. This frame converts unit from down-flow to horizontal air flow. The 37 inch (940mm) horizontal frame meets National Roofing Code requirements. The roof mounting frames are recommended in all other applications but not required. If the LGA / LCA / LHA units are not mounted on a flat (roof) surface, they MUST be supported under all edges and under the middle of the unit to prevent sagging. The units MUST be mounted level within 1/16" per linear foot or 5mm per meter in any direction.

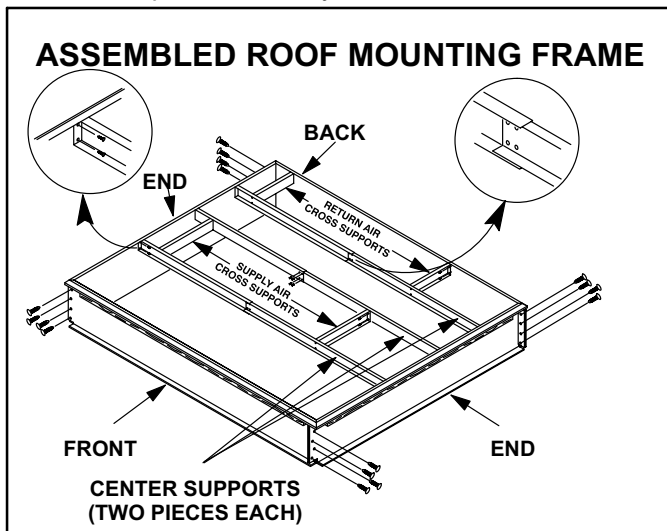

FIGURE 32

The assembled LARMF18/36 mounting frame is shown in figure 32. Refer to the roof mounting frame installation instructions for details of proper assembly and mounting. The roof mounting frame MUST be squared to the roof and level before mounting. Plenum system MUST be installed before the unit is set on the mounting frame. Typical roof curbing and flashing is shown in figure 33. Refer to the roof mounting frame installation instructions for proper plenum construction and attachment.

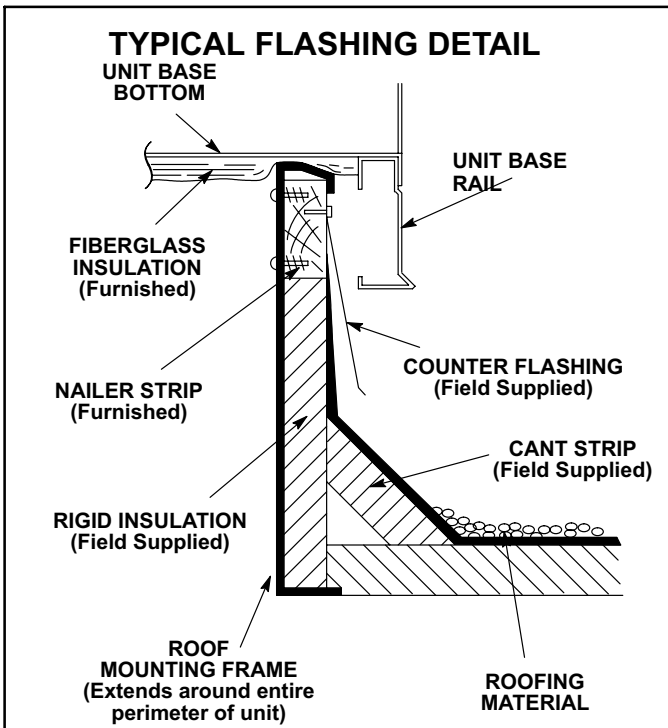

FIGURE 33

B-Transitions

Optional supply/return transitions LASRT18/21/24 are available for use with LGA / LCA / LHA series units utilizing optional LARMF18/36 roof mounting frame. Transition must be installed in the LARMF18/36 mounting frame before mounting the unit to the frame. Refer to the manufacturer's instructions included with the transition for detailed installation procedures.

C-Supply and Return Diffusers

Optional flush mount diffuser/return FD11 and extended mount diffuser/return RTD11 are available for use with the LGA / LCA / LHA units. Refer to manufacturer's instructions included with transition for detailed installation procedures.

D-LAOD(M)18/24 Outdoor Air Dampers

LAOD(M)18/24 consists of a set of dampers which may be manually or motor (M) operated to allow up to 25 percent outside air into the system at all times (see figure 34). Both air dampers can be installed in LGA / LHA / LCA units. Washable filter supplied with the outdoor air dampers can be cleaned with water and a mild detergent. It should be sprayed with Filter Handicoater when dry prior to reinstallation. Filter Handicoater is R.P. Products coating no. 418 and is available as Lennox Part No. P-8-5069.

E-LAREMD18/24 Economizer

(Field or Factory Installed)

The optional LAREMD18/24 economizer can be used with LGA / LCA / LHA units in downflow and horizontal air discharge applications. The LAREMD18 / 24 economizer uses outdoor air for free cooling when temperature and/or humidity is suitable. An economizer hood is required and must be ordered separately.

NOTE - Gravity exhaust dampers are required with power exhaust.

The economizer is controlled by the economizer control module A56 which connects to the main control module A55. Both boards are part of the Integrated Modular Control (IMC) which controls "L" series unit operation. The economizer will operate in one of four modes. Each mode requires a different EM1 economizer DIP switch setting. Each mode also requires different sensors.

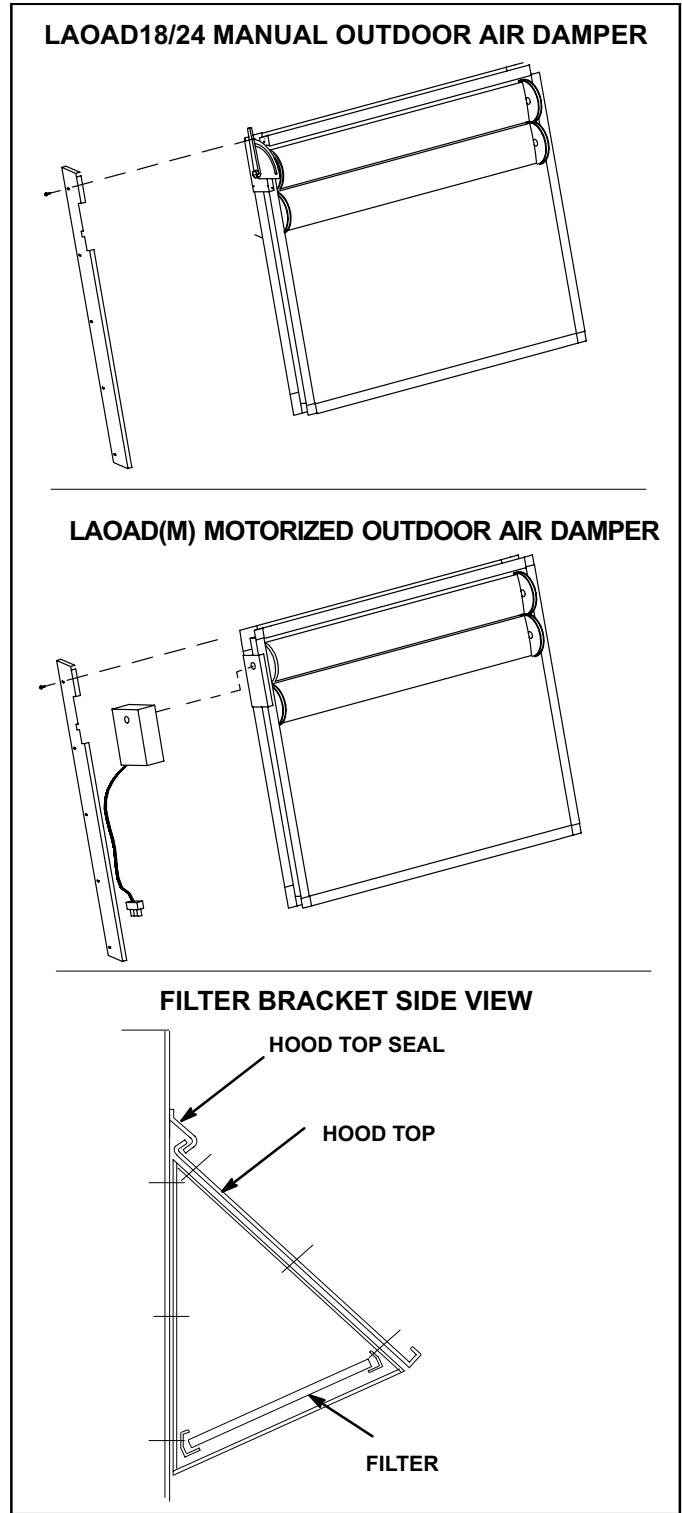

FIGURE 34

1-"TMP" MODE (SENSIBLE TEMPERATURE)

In the "TMP" mode, the IMC uses input from the factory installed RT6 Supply Air Sensor, RT16 Return Air Sensor, and RT17 Outdoor Air Sensor to determine suitability of outside air and economizer damper operation. When outdoor sensible

temperature is less than return air sensible temperature, outdoor air is used for cooling. This may be supplemented by mechanical cooling to meet comfort demands. This application does not require additional optional sensors.

2-“ODE” MODE (OUTDOOR ENTHALPY)

The “ODE” or outdoor enthalpy mode requires a field-provided and -installed Honeywell C7400 enthalpy sensor (16K96). The sensor monitors outdoor air temperature and humidity (enthalpy). When outdoor air enthalpy is below the enthalpy control setpoint, the economizer modulates to allow outdoor air for free cooling.

3-“DIF” MODE (DIFFERENTIAL ENTHALPY)

The “DIF” or differential enthalpy mode requires two field-provided and -installed Honeywell C7400 enthalpy sensors (16K97). One sensor is installed in the outside air opening and the other sensor is installed in the return air opening. When the outdoor air enthalpy is below the return air enthalpy, the economizer opens to bring in outdoor air for free cooling.

4-“GLO” MODE (GLOBAL)

Global Mode - The “GLO” or global mode is used with an energy management system which includes a global control feature. Global control is used when multiple units (in one location) respond to a single outdoor air sensor. Each energy management system uses a specific type of outdoor sensor which is installed and wired by the controls contractor.

Motorized Outdoor Air Damper - The “GLO” mode is also used when a motorized outdoor air damper is installed in the system.

NOTE - All economizer modes of operation will modulate dampers to 55°F (13°C) supply air.

F-LAGED(H)18/24 Gravity Exhaust Dampers

LAGED(H)18/24 dampers are used with LGA / LCA / LHA series units. LAGED dampers are used in downflow and LAGEDH are used in horizontal air discharge applications. LAGED(H) gravity exhaust dampers are installed in the return air plenum (see figure 35). The dampers must be used any time an economizer or power exhaust fans are applied to LGA / LCA / LHA series units.

Gravity exhaust dampers allow exhaust air to be discharged from the system when an economizer and/or power exhaust is operating. Gravity exhaust dampers also prevent outdoor air infiltration during unit off cycle. See installation instructions for more detail.

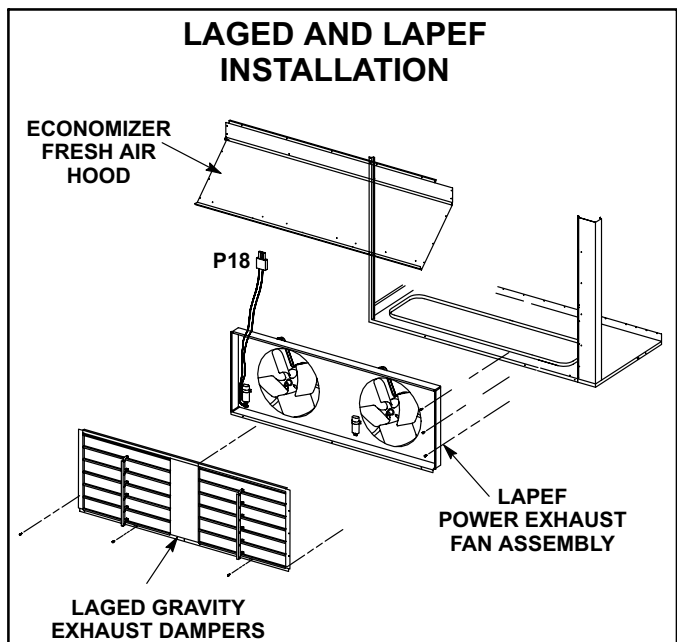

FIGURE 35

G-LAPEF18/24 Power Exhaust Fans

LAPEF18/24 power exhaust fans are used with LGA / LCA / LHA series units. LAPEF (requires optional down-flow gravity exhaust dampers and LAREMD economizers) are used in downflow applications only. Power exhaust fans provide exhaust air pressure relief and also run when return air dampers are closed and supply air blowers are operating. Figure 35 shows location of the LAPEF. See installation instructions for more detail.

H-Optional Cold Weather Kit (Canada only)

Electric heater is available to automatically control the minimum temperature in the gas burner compartment. Heater is C.G.A. certified to allow cold weather operation of unit down to -60°F (-50°C).

The kit includes the following parts:

- 1- Transformer (T20) is a 600V to 120/240V stepdown transformer mounted in the blower compartment.
- 2- T20 has two in line fuses (F20), one on each leg of the transformer. Both are rated at 15 amps.
- 3- The strip heater (HR6) is located as close as possible to the gas valve. It is wired in series with T20. The strip heater is rated at 500 Watts
- 4- A thermostat mounting box is installed on the vestibule of the heating compartment. Included in the box are the following thermostat switches:
 - a - Thermostat switch (S59) is an auto-reset SPST N.C. switch which opens on a temperature drop. The switch is wired in series with 24v power and the combustion air blower switch. When the temperature

drops below -20°F (28.9°C) the switch opens and the gas heat section is de-energized. The switch automatically resets when the heating compartment temperature reaches 10°F (-12.2°C).

- b - Thermostat switch (S60) is an auto-reset SPST N.C. switch which opens on a temperature rise. The switch is wired in series with HR6 and T20. When the temperature rises above 20°F (-6.7°C) the switch opens and the electric heater is de-energized. The switch automatically resets when the heating compartment temperature reaches -10°F (23.3°C).
- c - Thermostat switch (S61) is an auto-reset SPST N.O. switch which closes on a temperature drop. The switch is wired in series with HR6 and T20. When temperature drops below 20°F (-6.7°C) the switch closes and electric heater is energized. The switch automatically opens when heating compartment temperature reaches 50°F (10°C).

I-Control Systems

Three different types of control systems may be used with the LGA / LCA / LHA series units. All thermostat wiring is connected to terminal block TB1 located in the control box of the unit. Each thermostat has additional control options available. See thermostat installation instructions for more detail.

- 1- Electro-mechanical thermostat (13F06)
The electro-mechanical thermostat is a two stage heat / two stage cool thermostat with dual temperature levers. A non-switching or manual system switch subbase may be used.
- 2- Electronic thermostat (see price book)
Any two stage heat / two stage cool electronic thermostat may be used.
- 3- Honeywell T7300 thermostat (81G59)
The Honeywell T7300 thermostat is a programmable, internal or optional remote temperature sensing thermostat. The T7300 provides occupied and unoccupied changeover control.

J-Smoke Detectors A17 and A64

Photoelectric smoke detectors are a factory installed option. The smoke detectors can be installed in the supply air section (A64), return air section (A17), or in both the supply and return air section. Wiring for the smoke detectors are shown on the temperature control section (C2) wiring diagram in back of this manual.

K-Blower Proving Switch S52

The blower proving switch monitors blower operation and locks out the unit in case of blower failure. The switch is N.O. and closes at .14" W.C. (34.9 Pa) The switch is mounted on the upper left hand corner of the blower deck. Wiring for the blower proving switch is shown on the temperature control section (C2) wiring diagram in back of this manual.

L-Dirty Filter Switch S27

The dirty filter switch senses static pressure increase indicating a dirty filter condition. The switch is N.O. and closes at 1" W.C. (248.6 Pa) The switch is mounted on the top filter channel corner. Wiring for the dirty filter switch is shown on the temperature control section (C2) wiring diagram in back of this manual.

M-Indoor Air Quality (CO₂) Sensor A63

The indoor air quality sensor monitors CO₂ levels and reports the levels to the main control module A55. The board adjusts the economizer dampers according to the CO₂ levels. The sensor is mounted next to the indoor thermostat or in the return air duct. Refer to the indoor air quality sensor installation instructions for proper adjustment. Wiring for the indoor air quality switch is shown on the temperature control section (C2) wiring diagram in back of this manual.

N-LP / Propane Kit

Two natural to LP / propane gas changeover kits are required for gas conversion on LGA180/210/240 series units (one for each gas heat section). The kit includes one gas valve, eleven burner orifices, and three stickers. For more detail refer to the natural to LP gas changeover kit installation instructions.

O-Factory Installed Humiditrol LGA/LCA180, 210 & 240 Units

General

Humiditrol units provide a dehumidifying mode of operation. These units contain a reheat coil adjacent to and downstream of the evaporator coil. Reheat coil solenoid valves, L14 and L30, route hot discharge gas from the compressor to the reheat coil. Return air pulled across the evaporator coil is cooled and dehumidified; the reheat coil adds heat to supply air.

See figure 36 for RH1 reheat control board, figure 37 for 180 reheat refrigerant routing, figure 38 for 180 standard cooling refrigerant routing, figure 39 for 210 and 240 reheat refrigerant routing, and figure 40 for 210 and 240 standard cooling refrigerant routing.

L14 and L30 Reheat Coil Solenoid Valves

When IMC board input (P114-10) indicates room conditions require dehumidification, L14 and L30 reheat valves are energized (RH1 board P175-3 and -4) and refrigerant is routed to the reheat coil.

RH1 Humiditrol Board

The RH1 add-on board is factory-installed in all Humiditrol units. RH1 is located on the M1 board underneath either the A58 (G1) or A60 (E1) board.

Reheat Setpoint

Reheat is factory-set to energize when indoor relative humidity rises above 60% (default). Reheat will terminate when the indoor relative humidity falls 3% below setpoint, or 57% (default). The reheat setpoint can be adjusted by changing ECTO 4.25 . A setting of 100% will disable reheat. The reheat setpoint can also be adjusted using an optional Network Control Panel (NCP).

A91 Humidity Sensor

Relative humidity should correspond to the sensor (A91) output voltage listed in table 29. For example: if indoor air relative humidity is 80% ± 3%, the humidity sensor output should read 8.00VDC.

Check the sensor output annually for accuracy. Keep the air intake openings on the sensor clean and free of obstructions and debris.

Read Relative Humidity At IMC

Turn MODE DIP “TEMP” switch #4 “ON”. Display will alternately flash from readout to output. A single push on the pushbutton will toggle the readout upward from .0 to .7 incrementally. A double push will toggle the readout downward from .7 to .0 incrementally. Readout .7 indicates percent relative humidity.

TABLE 29

Relative Humidity (%RH ± 3%)	Sensor Output (VDC)
20	2.00
30	3.00
40	4.00
50	5.00
60	6.00
70	7.00
80	8.00
90	9.00

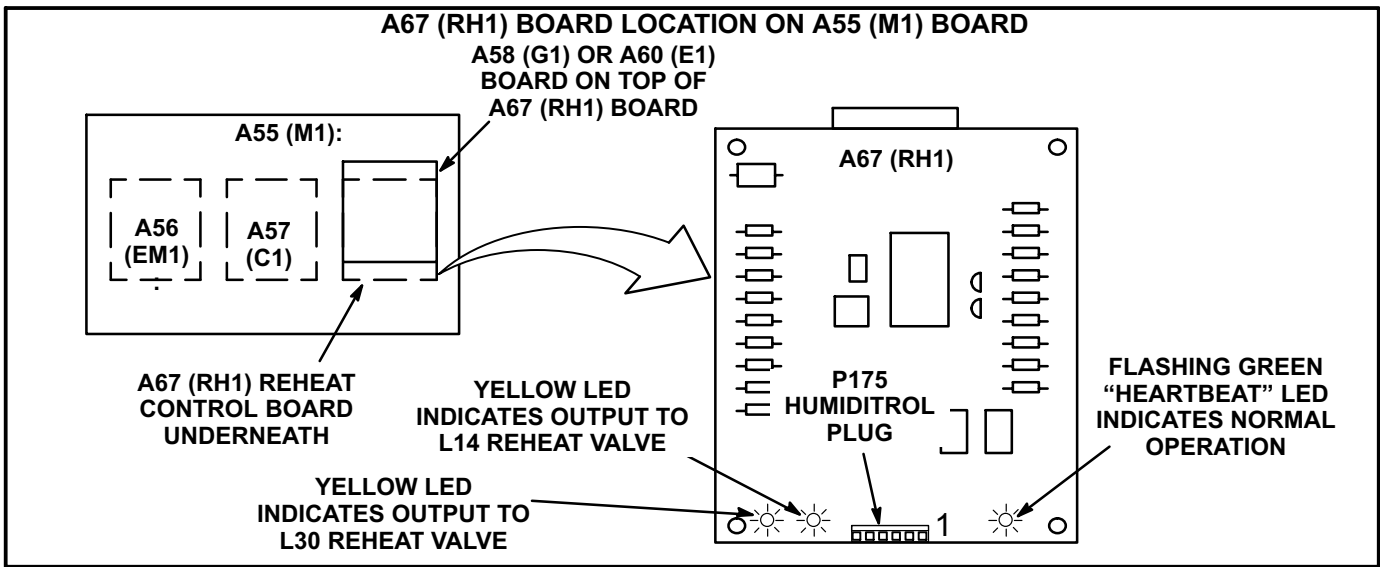
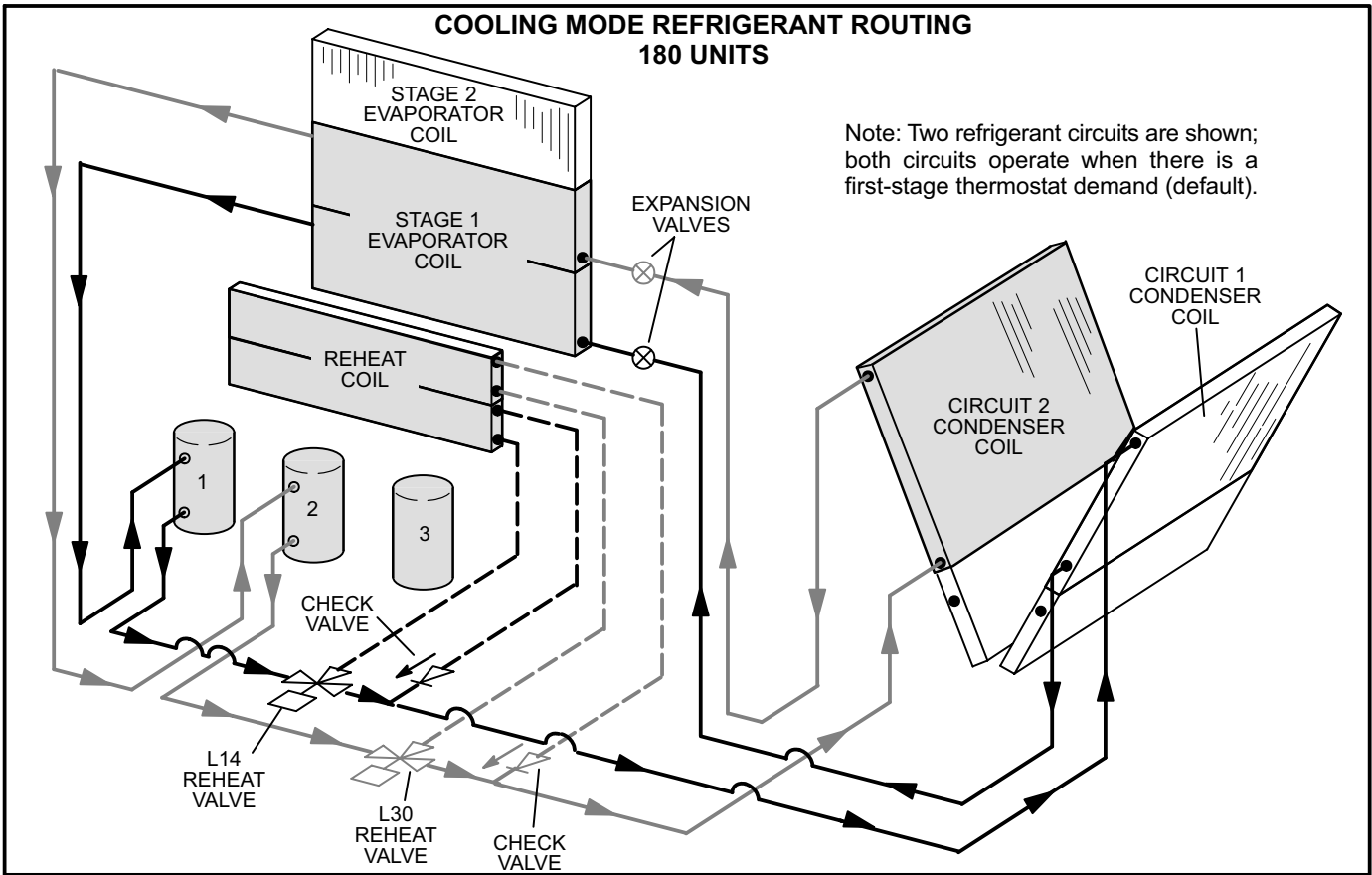
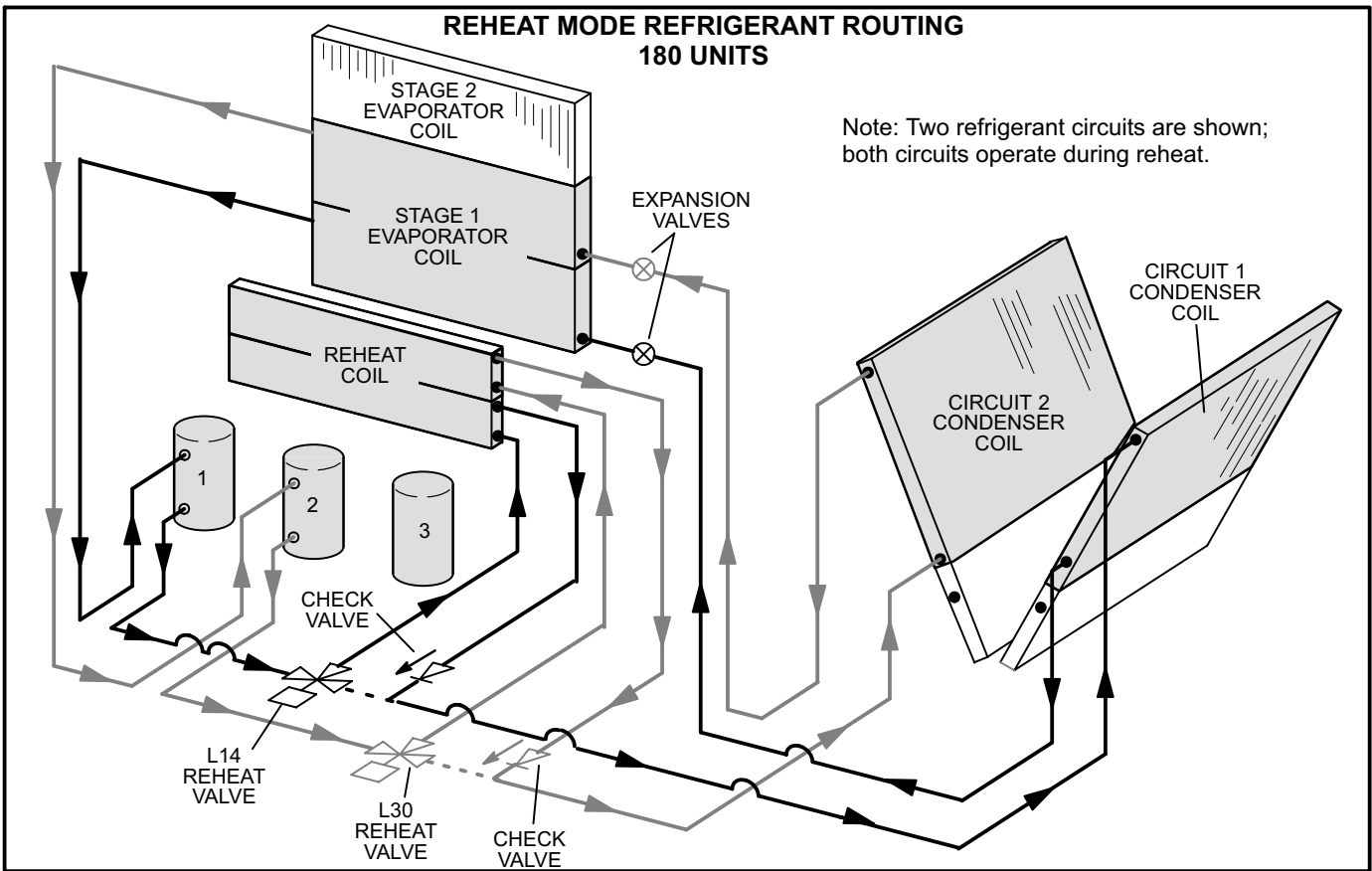

FIGURE 36



**REHEAT MODE REFRIGERANT ROUTING
210 AND 240 UNITS**

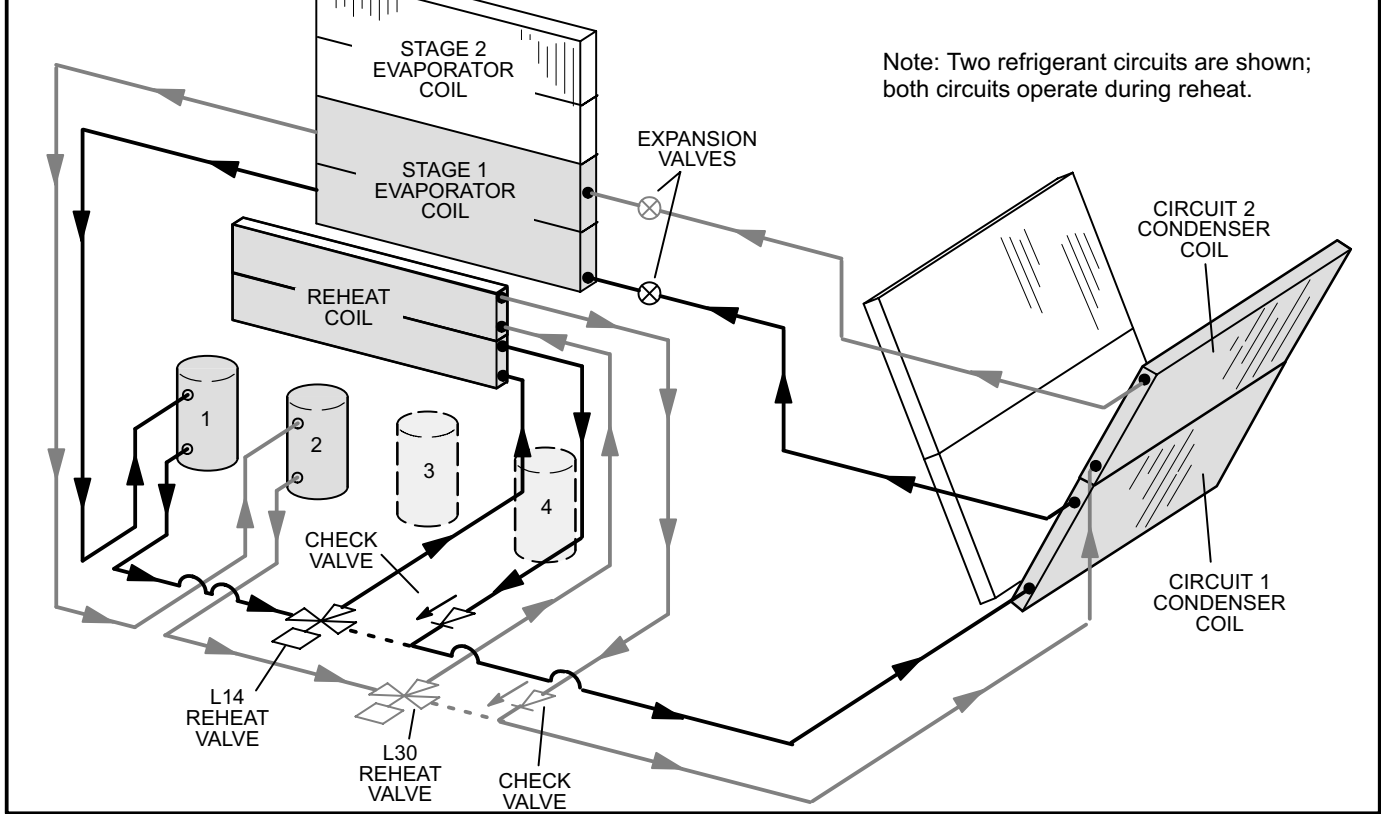

FIGURE 39

**COOLING MODE REFRIGERANT ROUTING
210 AND 240 UNITS**

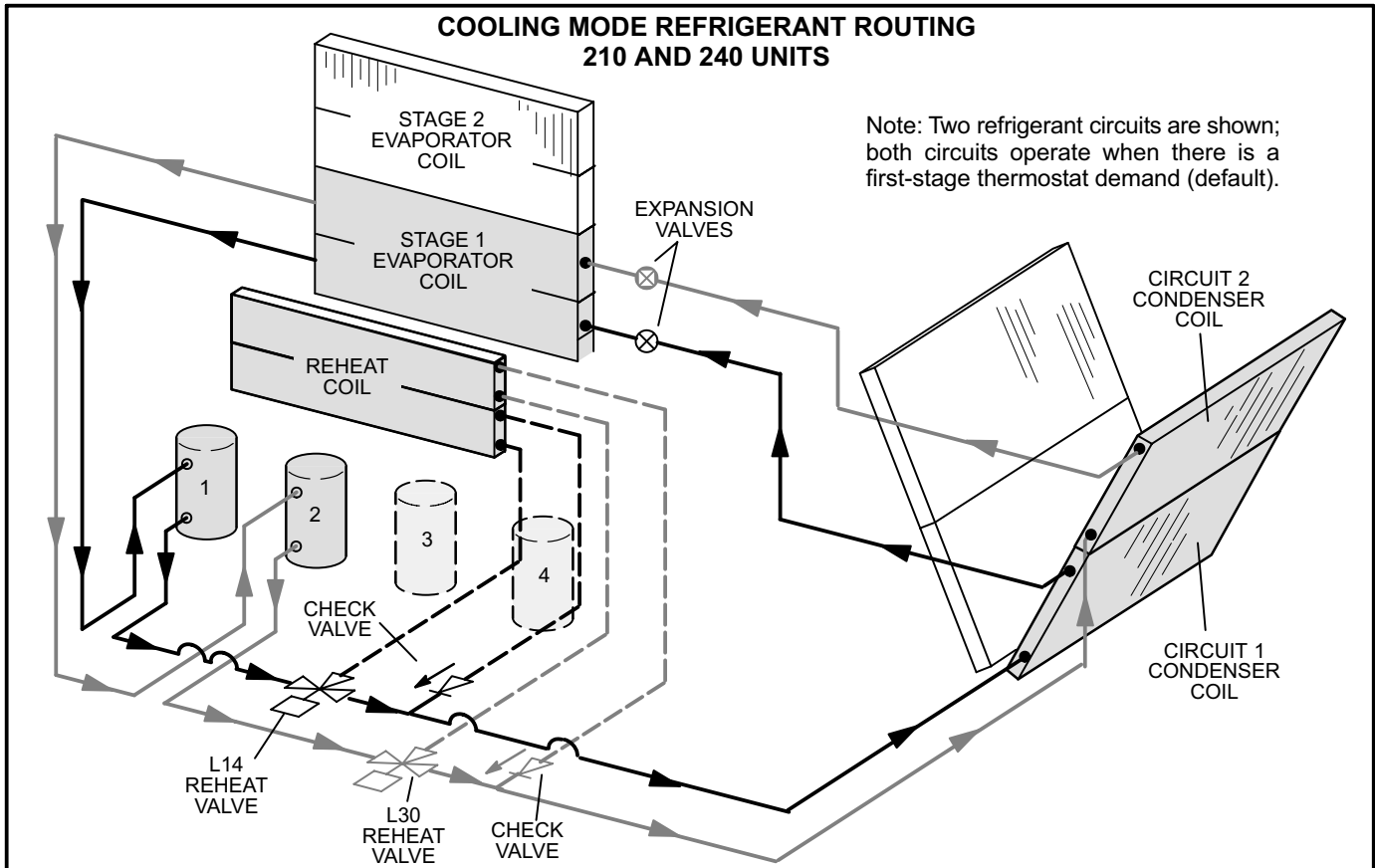

FIGURE 40

Check-Out

Test Humiditrol operation using the following procedure.

- 1- Make sure RH sensor is wired as shown in figure 41 or 42.
- 2- Set IMC ECTO system mode parameter 6.01 to option 0 (default local thermostat mode).
- 3- Set IMC ECTO reheat setpoint parameter 4.25 to option 0 (% relative humidity).
- 4- Jumper the following TB1 terminals:
 - 7 & 8 (occupied mode)
 - 6 & 3 (blower demand G)
 - 6 & 18 (Y1 cooling demand)

On 156 and 180 units, the blower, compressor 1 and compressor 2 (reheat), and compressor 3 (cooling) should be operating. On 210, 240, and 300S units, the blower, compressor 1 and compressor 2 (reheat), and compressor 3 and 4 (cooling) should be operating. L14 and L30 LED's on the A67 board should also be ON, indicating the reheat valves are energized.

- 5- Disconnect the jumper between TB1 terminals 6 & 18 (Y1) to end the cooling demand.
- 6- Press the IMC pushbutton to by-pass the compressor minimum run delay.

180 Units -

Compressor 3 (cooling) should de-energize, compressor 1 and 2 (reheat) should continue to operate, and L14 and L30 LED's should still be ON.

210 and 240 Units -

Compressor 3 and 4 (cooling) should de-energize, compressor 1 and 2 (reheat) should continue to operate, and L14 and L30 LED's should still be ON.

- 7- Disconnect the jumper between TB1 terminals 7&8 (occupied mode).

Compressor 1 and 2 (reheat) should de-energize, L14 and L30 LED's should go OFF, blower should still be energized.

- 8- **When check-out is complete, remove all jumpers, set ECTO 4.25 back to the proper humidity setpoint, and set ECTO 6.01 to the proper setting.**

Reheat Operation

The following conditions must be met before reheat will be energized:

- 1- Blower must be operating.
- 2- System must be in occupied mode.
- 3- System must NOT be operating in heating mode.
- 4- One cooling demand is required if the unit has been in heating mode, the IMC has been reset, or at initial unit start-up.

IMPORTANT - Free cooling does not operate during reheat. Free cooling will operate as shown in the IMC manual.

Reheat will operate as shown in table 30.

Units are shipped from the factory to provide two stages of cooling. (ECTO 5.04 option 2 and 6.01 option 0).

Three stages of cooling is available in zone sensor mode (ECTO 6.01 set to option 1, 2, or 3). Three stages of cooling is also available by installing a transfer relay and a three-stage thermostat; ECTO 5.04 must be set to option 3. Refer to the Main Control Operation section in the IMC manual when using the transfer relay.

Four stages of cooling is available in zone sensor mode (ECTO 6.01 set to option 1, 2, or 3) on units with four compressors (C210, 240, 300S).

Compressors are not de-energized when unit operation changes from cooling to reheat or from reheat to cooling. Instead, L14 and L30 reheat valves are energized (reheat) or de-energized (cooling).

NOTE - Another thermostat staging option is available which allows both compressors to be energized during free cooling. See ECTO 5.04 option 1 in IMC manual.

24 VOLT FIELD WIRING WITH IMC SET IN LOCAL THERMOSTAT MODE (ECTO 6.01 OPTION 0)

JUMPER TERMINALS 8 & 9
WHEN THERMOSTAT HAS NO
NIGHT SETBACK TERMINALS

Note - On electro-mechanical ther-
mostats set anticipator at 0.1 amps.

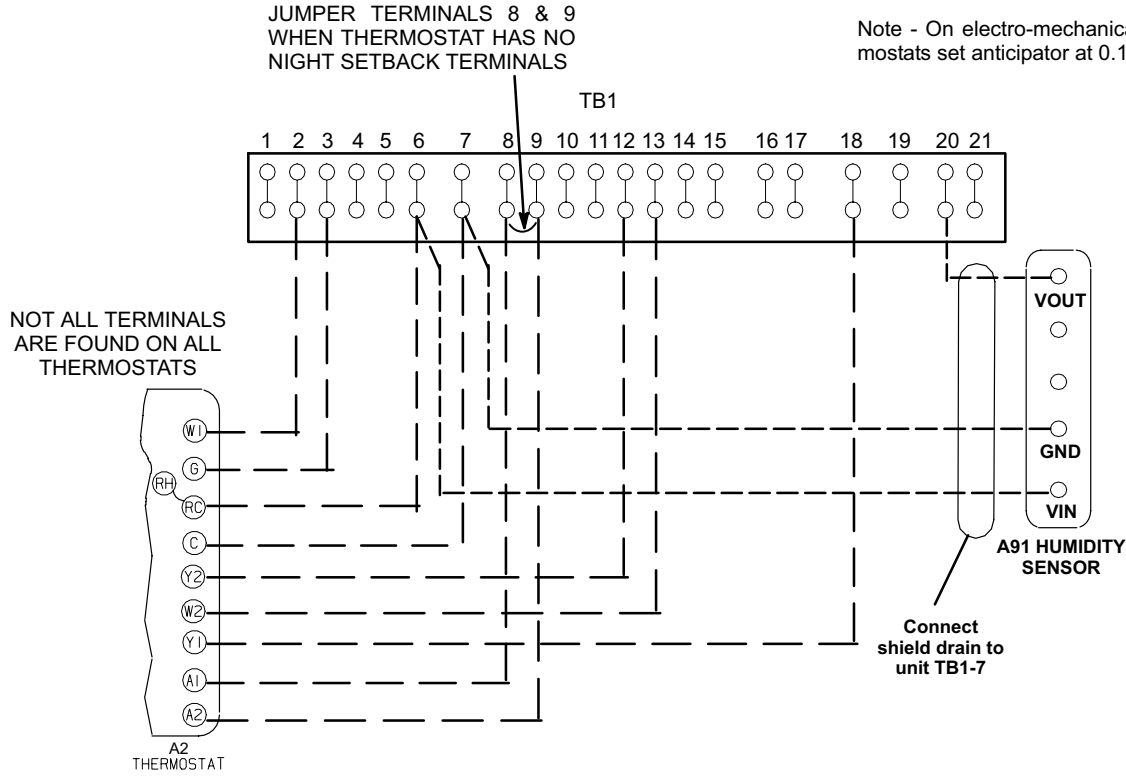

FIGURE 41

24 VOLT FIELD WIRING IN ZONE SENSOR MODE (ECTO 6.01 OPTION 1, 2, OR 3)

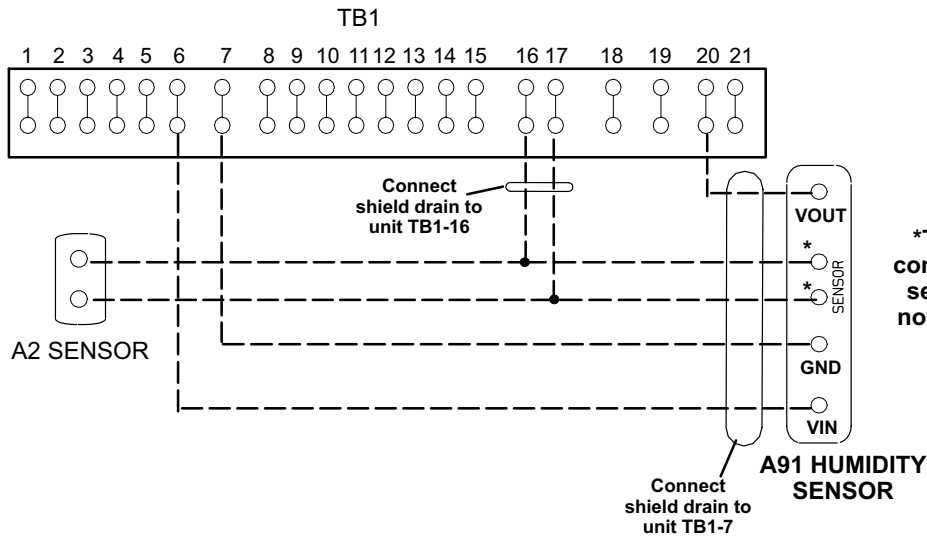

FIGURE 42

**TABLE 30
REHEAT OPERATION**

Two-Stage Thermostat - Default		
T'stat and Humidity Demands	Operation	
	180 (3-Compressors)	210 and 240 (4-Compressors)
Reheat Only	Compressor 1 & 2 Reheat	Compressor 1 & 2 Reheat
Reheat & Y1	Compressor 1 & 2 Reheat and Compressor 3 Cooling ¹	Compressor 1 & 2 Reheat and Compressor 3 & 4 Cooling ¹
Reheat & Y1 & Y2	Compressor 1, 2, & 3 Cooling ³	Compressor 1, 2, 3 & 4 Cooling ³
Three-Stage Thermostat (Transfer relay required)		
T'stat and Humidity Demands	Operation	
	180 (3-Compressors)	210 and 240 (4-Compressors)
Reheat Only	Compressor 1 & 2 Reheat	Compressor 1 & 2 Reheat
Reheat & Y1	Compressor 1 & 2 Reheat and Compressor 3 Cooling ¹	Compressor 1 & 2 Reheat and Compressor 3 Cooling ¹
Reheat Y1 & Y2	Compressor 1, & 2, Cooling ²	Compressor 1 & 2 Reheat and Compressor 3, & 4 Cooling ³
Reheat Y1 & Y2 & Y3	Compressor 1, 2, & 3 Cooling ³	Compressor 1, 2, 3, & 4 Cooling ⁴
Four-Stage Zone Sensor Mode		
Cooling* and Humidity** Demands	Operation	
	180 (3-Compressors)	210 and 240 (4-Compressors)
Reheat Only	Compressor 1 & 2 Reheat	Compressor 1 & 2 Reheat
Reheat & Y1	Compressor 1 & 2 Reheat and Compressor 3 Cooling ¹	Compressor 1 & 2 Reheat and Compressor 3 Cooling ¹
Reheat & Y1 & Y2	Compressor 1, & 2, Cooling ²	Compressor 1 & 2 Reheat and Compressor 3 & 4 Cooling ²
Reheat & Y1 & Y2 & Y3	Compressor 1, 2, & 3 Cooling ³	Compressor 1, 2, & 3 Cooling ³
Reheat & Y1 & Y2 & Y3 & Y4	Compressor 1, 2, & 3 Cooling ⁴	Compressor 1, 2, 3, & 4 Cooling ⁵

*Cooling stage is initiated when zone temperature is higher than the cooling setpoint plus the appropriate stage differential (ECTO 6.10, 6.12, 6.13, 6.14).

**Reheat demand is initiated when relative humidity is higher than relative humidity setpoint.

¹If there is no reheat demand and outdoor air is suitable, free cooling will operate.

²If there is no reheat demand and outdoor air is suitable, free cooling and compressor 1 will operate.

³If there is no reheat demand and outdoor air is suitable, free cooling and compressor 1 and 2 will operate.

⁴If there is no reheat demand and outdoor air is suitable, free cooling, compressor 1, 2, and 3 will operate.

⁵If there is no reheat demand and outdoor air is suitable, free cooling, compressor 1, 2, 3, and 4 will operate.

The following conditions must be met before reheat will be energized:

- 1- Blower must be operating.
- 2- System must be in occupied mode.
- 3- System must NOT be operating in heating mode.
- 4- One cooling demand is required if the unit has been in heating mode, the IMC has been reset, or at initial unit start-up.

VIII-WIRING DIAGRAMS AND OPERATION SEQUENCE

The following pages contain the wiring diagrams for LGA, LCA, LHA156H/180/210/240/300S series units. An economizer and thermostat are also shown. Each wiring diagram is followed by a sequence of operation. The sequence is outlined by numbered steps which correspond to circled numbers on the wiring diagrams.

Each wiring diagram is identified with a letter A, B, C, or D followed by a number. Each LGA / LCA / LHA unit wiring diagram is assigned a "B" number (likewise, each control system is assigned a "C" number, each heating section an "A" number and each economizer diagram a "D" number). Use the numbers when joining the schematics to help you identify how the unit is set up.

B6 diagram LGA, LCA156H/180 Y, G, J

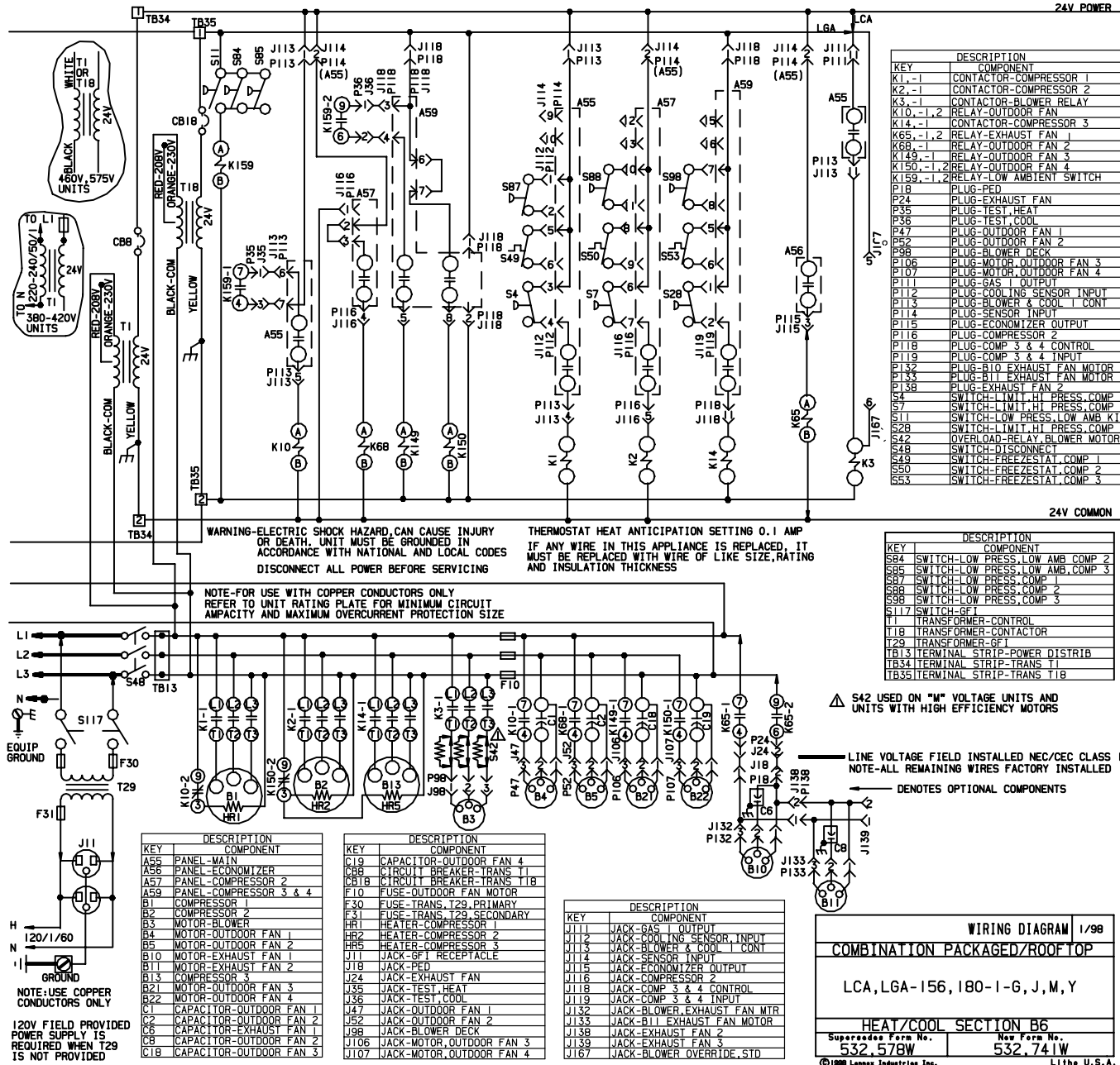

KEY	DESCRIPTION	COMPONENT
K1,-1	CONTACTOR-COMPRESSOR 1	
K2,-1	CONTACTOR-COMPRESSOR 2	
K3,-1	CONTACTOR-BLOWER RELAY	
K10,-1,2	RELAY-OUTDOOR FAN	
K14,-1	CONTACTOR-COMPRESSOR 3	
K65,-1,2	RELAY-EXHAUST FAN 1	
K66,-1	RELAY-OUTDOOR FAN 2	
K149,-1	RELAY-OUTDOOR FAN 3	
K150,-1,2	RELAY-OUTDOOR FAN 4	
K159,-1,2	RELAY-LOW AMBIENT SWITCH	
P18	PLUG-PED	
P24	PLUG-EXHAUST FAN	
P35	PLUG-TEST, HEAT	
P36	PLUG-TEST, COOL	
P47	PLUG-OUTDOOR FAN 1	
P52	PLUG-OUTDOOR FAN 2	
P98	PLUG-BLOWER DECK	
P106	PLUG-MOTOR, OUTDOOR FAN 3	
P107	PLUG-MOTOR, OUTDOOR FAN 4	
P111	PLUG-GAS 1 OUTPUT	
P112	PLUG-COOLING SENSOR INPUT	
P113	PLUG-BLOWER & COOL 1 CONT	
P114	PLUG-SENSOR INPUT	
P115	PLUG-ECONOMIZER OUTPUT	
P116	PLUG-COMPRESSOR 2	
P118	PLUG-COMP 3 & 4 CONTROL	
P119	PLUG-COMP 3 & 4 INPUT	
P134	PLUG-B10 EXHAUST FAN MOTOR	
P135	PLUG-B11 EXHAUST FAN MOTOR	
P138	PLUG-EXHAUST FAN 2	
S4	SWITCH-LIMIT, HI PRESS, COMP 1	
S7	SWITCH-LIMIT, HI PRESS, COMP 2	
S11	SWITCH-LOW PRESS, LOW AMB, KIT	
S2B	SWITCH-LIMIT, HI PRESS, COMP 3	
S42	OVERLOAD-RELAY, BLOWER MOTOR	
S48	SWITCH-DISCONNECT	
S49	SWITCH-FREEZE/STAT, COMP 1	
S50	SWITCH-FREEZE/STAT, COMP 2	
S53	SWITCH-FREEZE/STAT, COMP 3	

KEY	DESCRIPTION	COMPONENT
S84	SWITCH-LOW PRESS, LOW AMB, COMP 2	
S85	SWITCH-LOW PRESS, LOW AMB, COMP 3	
S87	SWITCH-LOW PRESS, COMP 1	
S89	SWITCH-LOW PRESS, COMP 2	
S98	SWITCH-LOW PRESS, COMP 3	
S117	SWITCH-GF1	
T1	TRANSFORMER-CONTROL	
T18	TRANSFORMER-CONTACTOR	
T29	TRANSFORMER-GF	
TB13	TERMINAL STRIP-POWER DISTRIB	
TB34	TERMINAL STRIP-TRANS T1	
TB35	TERMINAL STRIP-TRANS T18	

KEY	DESCRIPTION	COMPONENT
A55	PANEL-MAIN	
A56	PANEL-ECONOMIZER	
A57	PANEL-COMPRESSOR 2	
A59	PANEL-COMPRESSOR 3 & 4	
B1	COMPRESSOR 1	
B2	COMPRESSOR 2	
B3	MOTOR-BLOWER	
B4	MOTOR-OUTDOOR FAN 1	
B5	MOTOR-OUTDOOR FAN 2	
B10	MOTOR-EXHAUST FAN 1	
B11	MOTOR-EXHAUST FAN 2	
B13	COMPRESSOR 3	
B21	MOTOR-OUTDOOR FAN 3	
B22	MOTOR-OUTDOOR FAN 4	
C1	CAPACITOR-OUTDOOR FAN 1	
C2	CAPACITOR-OUTDOOR FAN 2	
C6	CAPACITOR-EXHAUST FAN 1	
C9	CAPACITOR-OUTDOOR FAN 2	
C18	CAPACITOR-OUTDOOR FAN 3	

KEY	DESCRIPTION	COMPONENT
C19	CAPACITOR-OUTDOOR FAN 4	
CB8	CIRCUIT BREAKER-TRANS T1	
CB18	CIRCUIT BREAKER-TRANS T18	
F10	FUSE-OUTDOOR FAN MOTOR	
F30	FUSE-TRANS, T29, PRIMARY	
F31	FUSE-TRANS, T29, SECONDARY	
HR1	HEATER-COMPRESSOR 1	
HR2	HEATER-COMPRESSOR 2	
HR5	HEATER-COMPRESSOR 3	
J11	JACK-GF1 RECEPTACLE	
J18	JACK-PED	
J24	JACK-EXHAUST FAN	
J35	JACK-TEST, HEAT	
J36	JACK-TEST, COOL	
J47	JACK-OUTDOOR FAN 1	
J52	JACK-OUTDOOR FAN 2	
J98	JACK-BLOWER DECK	
J106	JACK-MOTOR, OUTDOOR FAN 3	
J107	JACK-MOTOR, OUTDOOR FAN 4	

KEY	DESCRIPTION	COMPONENT
J111	JACK-GAS 1 OUTPUT	
J112	JACK-COOLING SENSOR INPUT	
J113	JACK-BLOWER & COOL 1 CONT	
J114	JACK-SENSOR INPUT	
J115	JACK-ECONOMIZER OUTPUT	
J116	JACK-COMPRESSOR 2	
J118	JACK-COMP 3 & 4 CONTROL	
J119	JACK-COMP 3 & 4 INPUT	
J132	JACK-BLOWER, EXHAUST FAN MTR	
J133	JACK-B11 EXHAUST FAN MOTOR	
J138	JACK-EXHAUST FAN 2	
J139	JACK-EXHAUST FAN 3	
J167	JACK-BLOWER OVERRIDE, STD	

WIRING DIAGRAM 1/98

COMBINATION PACKAGED/ROOFTOP

LCA, LGA-156, 180-1-G, J, M, Y

HEAT/COOL SECTION B6

Supersedes Form No. 532.57BW	New Form No. 532.741W
--	---------------------------------

©1998 Lennox Industries Inc. L11th U.S.A.

120V FIELD PROVIDED
POWER SUPPLY IS
REQUIRED WHEN T29
IS NOT PROVIDED

B7 diagram LGA, LCA210/240/300S Y, G, J

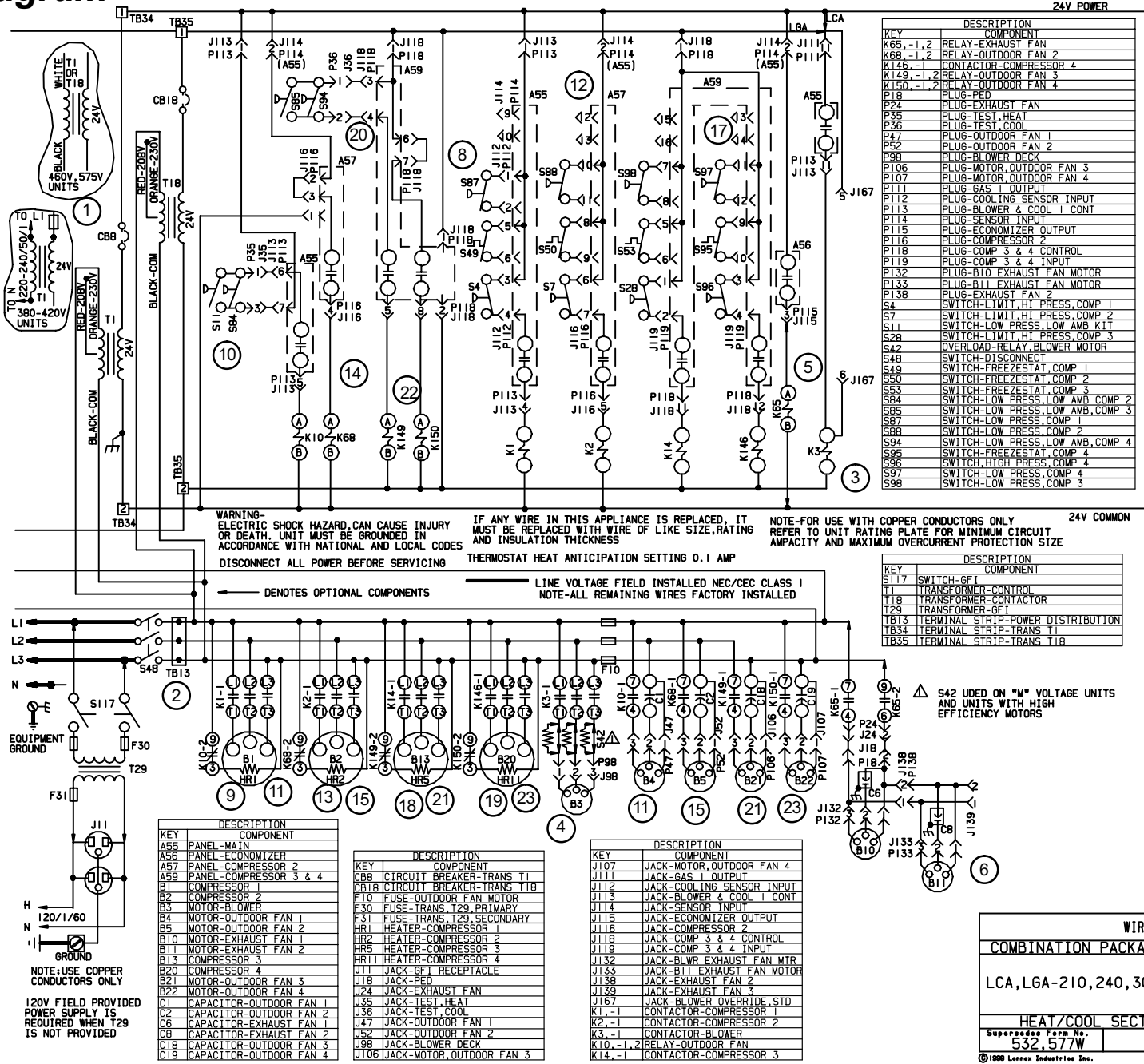

24V POWER

KEY	DESCRIPTION
K65, -1, 2	RELAY-EXHAUST FAN
K68, -1, 2	RELAY-OUTDOOR FAN 2
K146, -1	CONTACTOR-COMPRESSOR 4
K149, -1, 2	RELAY-OUTDOOR FAN 3
K150, -1, 2	RELAY-OUTDOOR FAN 4
P18	PLUG-PED
P24	PLUG-EXHAUST FAN
P35	PLUG-TEST HEAT
P36	PLUG-TEST COOL
P47	PLUG-OUTDOOR FAN 1
P52	PLUG-OUTDOOR FAN 2
P98	PLUG-BLOWER DECK
P106	PLUG-MOTOR, OUTDOOR FAN 3
P107	PLUG-MOTOR, OUTDOOR FAN 4
P111	PLUG-GAS 1 OUTPUT
P112	PLUG-COOLING SENSOR INPUT
P113	PLUG-BLOWER & COOL 1 CONT
P114	PLUG-SENSOR INPUT
P115	PLUG-ECONOMIZER OUTPUT
P116	PLUG-COMPRESSOR 2
P118	PLUG-COMP 3 & 4 CONTROL
P119	PLUG-COMP 3 & 4 INPUT
P132	PLUG-B10 EXHAUST FAN MOTOR
P133	PLUG-B11 EXHAUST FAN MOTOR
P138	PLUG-EXHAUST FAN 2
S4	SWITCH-LIMIT, HI PRESS, COMP 1
S7	SWITCH-LIMIT, HI PRESS, COMP 2
S11	SWITCH-LOW PRESS, LOW AMB KIT
S28	SWITCH-LIMIT, HI PRESS, COMP 3
S42	OVERLOAD-RELAY, BLOWER MOTOR
S48	SWITCH-DISCONNECT
S49	SWITCH-FREEZESTAT, COMP 1
S50	SWITCH-FREEZESTAT, COMP 2
S53	SWITCH-FREEZESTAT, COMP 3
S84	SWITCH-LOW PRESS, LOW AMB, COMP 2
S85	SWITCH-LOW PRESS, LOW AMB, COMP 3
S87	SWITCH-LOW PRESS, COMP 1
S88	SWITCH-LOW PRESS, COMP 2
S94	SWITCH-LOW PRESS, LOW AMB, COMP 4
S95	SWITCH-FREEZESTAT, COMP 4
S96	SWITCH, HIGH PRESS, COMP 4
S97	SWITCH-LOW PRESS, COMP 4
S98	SWITCH-LOW PRESS, COMP 3

WARNING- ELECTRIC SHOCK HAZARD, CAN CAUSE INJURY OR DEATH. UNIT MUST BE GROUNDED IN ACCORDANCE WITH NATIONAL AND LOCAL CODES. DISCONNECT ALL POWER BEFORE SERVICING.

IF ANY WIRE IN THIS APPLIANCE IS REPLACED, IT MUST BE REPLACED WITH WIRE OF LIKE SIZE, RATING AND INSULATION THICKNESS.

NOTE-FOR USE WITH COPPER CONDUCTORS ONLY REFER TO UNIT RATING PLATE FOR MINIMUM CIRCUIT AMPACITY AND MAXIMUM OVERCURRENT PROTECTION SIZE.

24V COMMON

KEY	DESCRIPTION
S117	SWITCH-GFI
T1	TRANSFORMER-CONTROL
T18	TRANSFORMER-CONTACTOR
T29	TRANSFORMER-GF
TB13	TERMINAL STRIP-POWER DISTRIBUTION
TB34	TERMINAL STRIP-TRANS T1
TB35	TERMINAL STRIP-TRANS T18

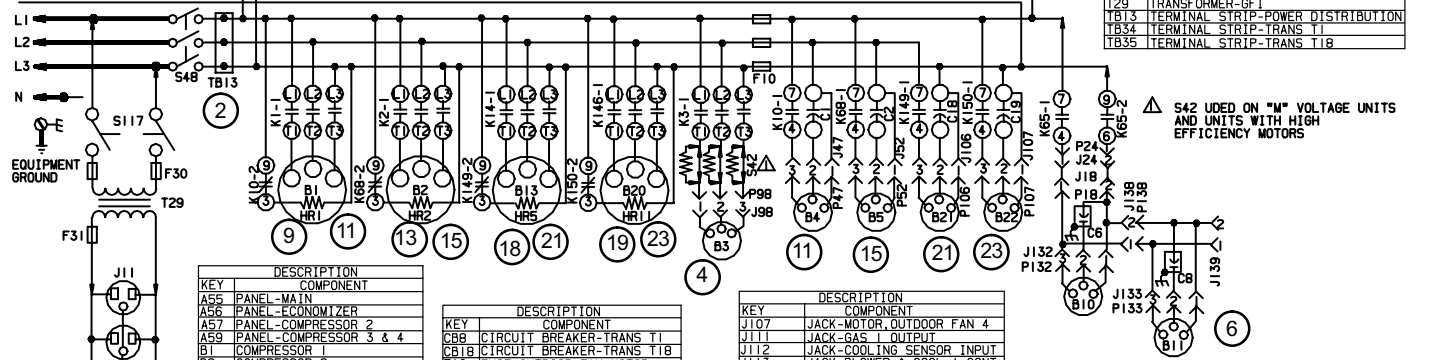

NOTE: USE COPPER CONDUCTORS ONLY

120V FIELD PROVIDED POWER SUPPLY IS REQUIRED WHEN T29 IS NOT PROVIDED

KEY	DESCRIPTION
A55	PANEL-MAIN
A56	PANEL-ECONOMIZER
A57	PANEL-COMPRESSOR 2
A59	PANEL-COMPRESSOR 3 & 4
B1	COMPRESSOR 1
B2	COMPRESSOR 2
B3	MOTOR-BLOWER
B4	MOTOR-OUTDOOR FAN 1
B5	MOTOR-OUTDOOR FAN 2
B10	MOTOR-EXHAUST FAN 1
B11	MOTOR-EXHAUST FAN 2
B13	COMPRESSOR 3
B20	COMPRESSOR 4
B21	MOTOR-OUTDOOR FAN 3
B22	MOTOR-OUTDOOR FAN 4
C1	CAPACITOR-OUTDOOR FAN 1
C2	CAPACITOR-OUTDOOR FAN 2
C6	CAPACITOR-EXHAUST FAN 1
C8	CAPACITOR-EXHAUST FAN 2
C18	CAPACITOR-OUTDOOR FAN 3
C19	CAPACITOR-OUTDOOR FAN 4

KEY	DESCRIPTION
F30	FUSE-OUTDOOR FAN MOTOR
F31	FUSE-TRANS, T29, PRIMARY
F31	FUSE-TRANS, T29, SECONDARY
HR1	HEATER-COMPRESSOR 2
HR2	HEATER-COMPRESSOR 3
HR5	HEATER-COMPRESSOR 4
HR11	HEATER-COMPRESSOR 4
J11	JACK-GFI RECEPTACLE
J18	JACK-PED
J24	JACK-EXHAUST FAN
J35	JACK-TEST, HEAT
J36	JACK-TEST, COOL
J47	JACK-OUTDOOR FAN 1
J52	JACK-OUTDOOR FAN 2
J98	JACK-BLOWER DECK
J106	JACK-MOTOR, OUTDOOR FAN 3

KEY	DESCRIPTION
J107	JACK-MOTOR, OUTDOOR FAN 4
J111	JACK-GAS 1 OUTPUT
J112	JACK-COOLING SENSOR INPUT
J113	JACK-BLOWER & COOL 1 CONT
J114	JACK-SENSOR INPUT
J115	JACK-ECONOMIZER OUTPUT
J116	JACK-COMPRESSOR 2
J118	JACK-COMP 3 & 4 CONTROL
J119	JACK-COMP 3 & 4 INPUT
J132	JACK-BLWR EXHAUST FAN MTR
J133	JACK-B11 EXHAUST FAN MOTOR
J138	JACK-EXHAUST FAN 2
J139	JACK-EXHAUST FAN 3
J167	JACK-BLOWER OVERRIDE, STD
K1, -1	CONTACTOR-COMPRESSOR 1
K2, -1	CONTACTOR-COMPRESSOR 2
K3, -1	CONTACTOR-BLOWER
K10, -1, 2	RELAY-OUTDOOR FAN
K14, -1	CONTACTOR-COMPRESSOR 3

WIRING DIAGRAM 1/99	
COMBINATION PACKAGED/ROOFTOP	
LCA, LGA-210, 240, 300S-1-G, J, M, Y	
HEAT/COOL SECTION B7	
Supersedes Form No. 532, 577W	Next Form No. 532, 740W
©1998 Lennox Industries Inc.	Li the U.S.A.

SEQUENCE OF OPERATION
B7 DIAGRAM - LGA, LCA210/240/300S Y, G, J
(B6 DIAGRAM - LGA, LCA156H/180 Y, G, J SIMILAR)

Power:

- 1- Line voltage from TB2, unit disconnect S48, or other factory or field installed optional power disconnects, such as CB10, energizes transformer T1 and T18. Transformer T1 provides 24VAC power to terminal strip TB34 and T18 provides 24VAC power to terminal strip TB35. The two terminal strips provide 24VAC power to the unit cooling, heating and blower controls and thermostat.
- 2- Terminal strip TB13 is also energized when the unit disconnect closes. TB13 supplies line voltage to compressor crankcase heaters, compressors, blower motors, and fan motors.

Blower Operation (OCP input must be on):

- 3- The main control module A55 receives a demand from thermostat terminal G. A55 energizes blower contactor K3 with 24VAC.
- 4- N.O. K3-1 closes, energizing blower B3.

Economizer Operation:

- 5- The economizer control module A56 receives a demand and energizes exhaust fan relay K65 with 24VAC at 50% (travel) outside air damper open (adjustable).
- 6- N.O. K65-1 and K65-2 both close, energizing exhaust fan motors B10 and B11.

1st Stage Cooling (both compressors B1 and B2 are energized):

- 7- First stage cooling demand energizes Y1 and G in the thermostat. G energizes blower, if blower is not already running (see step 3).
- 8- 24VAC is routed through TB34 to the main control module A55. After A55 proves N.C. low pressure switch S87, N.C. freezestat S49, and N.C. high pressure switch S4, compressor contactor K1 is energized.
- 9- N.O. contacts K1-1 close energizing compressor B1.
- 10- N.O. low ambient switch S11 and S84 close to energize condenser fan contactor K10.

NOTE: In 15 ton (52.8 kW) units, K10 is energized after K159-1 closes. K159 is energized by TB35 after one of the N.O. low ambient pressure switches S11, S84, and S85 closes.

- 11- N.O. contacts K10-1 close energizing condenser fan B4 and N.C. contacts K10-2 open de-energizing compressor 1 crankcase heater HR1.
- 12- Simultaneous with step 8, 24VAC is routed through the compressor 2 control module A57. After A57 proves N.C. low pressure switch S88, N.C. freezestat S50, and N.C. high pressure switch S7, compressor contactor K2 is energized.
- 13- N.O. contacts K2-1 close energizing compressor B2.
- 14- Compressor 2 control module A57 energizes condenser fan 2 relay K68.
- 15- N.O. contacts K68-1 close energizing condenser fan B5 and N.C. contacts K68-2 open de-energizing compressor 2 crankcase heater HR2.

2nd Stage Cooling (B13 in 15 ton (52.8 kW) and both B13 and B20 in 17.5 and 20 ton [61.5 and 70.3 kW] are energized):

- 16- Second stage cooling demand energizes Y2.
- 17- 24VAC is routed through TB35 to compressor 3 and 4 module A59. After A59 proves N.C. low pressure switches S98 and S97, N.C. freezestats S53 and S95, and N.C. high pressure switches S28 and S96, compressor contactors K14 and K146 are energized.
- 18- N.O. contacts K14-1 close energizing compressor B13.
- 19- N.O. contacts K146-1 close energizing compressor B20.
- 20- N.O. low ambient pressure switches S85 and S94 close to energize condenser fan relay K149.

NOTE: In 15 ton (52.8 kW) units, K149 is energized after K159-2 closes. K159 is energized by TB35 after one of the N.O. low ambient pressure switches S11, S84, and S85 closes.

- 21- N.O. contacts K149-1 close energizing condenser fan B21 and N.C. contacts K149-2 open de-energizing compressor 3 crankcase heater HR5.
- 22- Compressor 3 and 4 module A59 energizes condenser fan relay K150.
- 23- N.O. contacts K150-1 close energizing condenser fan B22 and N.C. contacts K150-2 open de-energizing compressor 4 crankcase heater HR11.

B15 diagram LHA180/240 Y, G, J

24V POWER

KEY	DESCRIPTION	COMPONENT
A9	PROTECTOR-COMPRESSOR 1	
A10	PROTECTOR-COMPRESSOR 2	
A55	PANEL-MAIN	
A56	PANEL-ECONOMIZER	
A61	PANEL-HEAT PUMP	
B1	COMPRESSOR 1	
B2	COMPRESSOR 2	
B3	MOTOR-BLOWER	
B4	MOTOR-OUTDOOR FAN 1	
B5	MOTOR-OUTDOOR FAN 2	
B10	MOTOR-EXHAUST FAN 1	
B11	MOTOR-EXHAUST FAN 2	
B21	MOTOR-OUTDOOR FAN 3	
B22	MOTOR-OUTDOOR FAN 4	
C1	CAPACITOR-OUTDOOR FAN 1	
C2	CAPACITOR-OUTDOOR FAN 2	
C6	CAPACITOR-EXHAUST FAN	
C8	CAPACITOR-OUTDOOR FAN 2	
C18	CAPACITOR-OUTDOOR FAN 4	

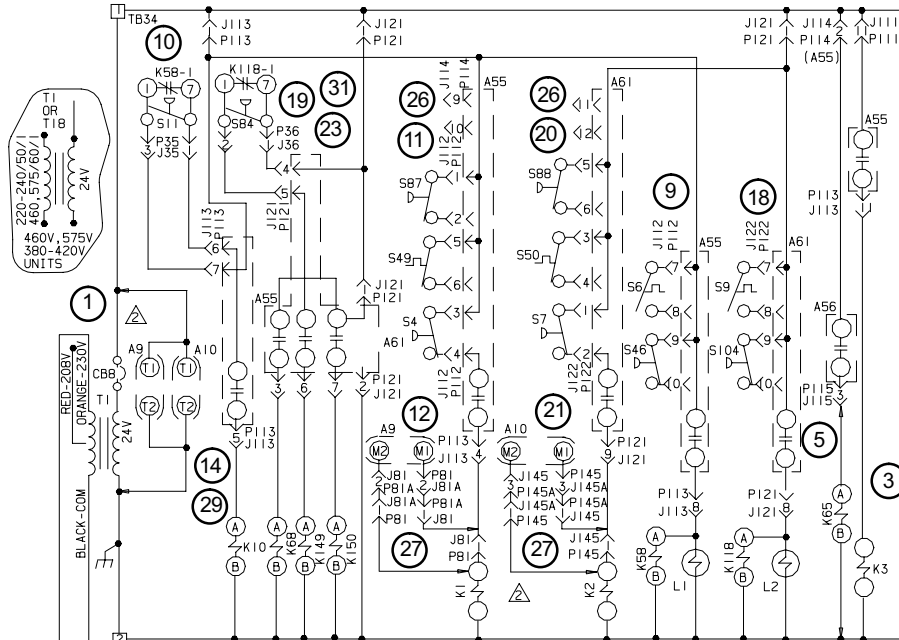

KEY	DESCRIPTION	COMPONENT
J121	JACK-HEAT PUMP CONTROL	
J122	JACK-HEAT PUMP INPUT	
J145	JACK-MOTOR PROTECTOR, COMP 2	
K1,-1	CONTACTOR-COMPRESSOR 1	
K2,-1	CONTACTOR-COMPRESSOR 2	
K3,-1	CONTACTOR-BLOWER RELAY	
K10,-1,2	RELAY-OUTDOOR FAN	
K5B,-1	RELAY-LOW AMBIENT KIT	
K65,-1,2	RELAY-EXHAUST FAN	
K6B,-1	RELAY-OUTDOOR FAN 2	
K11B,-1	RELAY-LOW AMBIENT KIT, COMP 2	
K149,-1,2	RELAY-OUTDOOR FAN 3	
K150,-1	RELAY-OUTDOOR FAN 4	
L1	VALVE-REVERSING 1	
L2	VALVE-REVERSING 2	
P1B	PLUG-PED	
P24	PLUG-EXHAUST FAN	
P35	PLUG-TEST, HEAT	
P36	PLUG-TEST, COOL	
P47	PLUG-OUTDOOR FAN 1	
P52	PLUG-OUTDOOR FAN 2	
PB1	PLUG-MOTOR PROTECTOR, COMP 1	
P9B	PLUG-BLOWER DECK	
PT06	PLUG-MOTOR, OUTDOOR FAN 3	
PT07	PLUG-MOTOR, OUTDOOR FAN 4	
PT11	PLUG-GAS 1 OUTPUT	
PT12	PLUG-COOLING SENSOR INPUT	
PT13	PLUG-BLOWER & COOL 1 CONT	
PT14	PLUG-SENSOR INPUT	
PT15	PLUG-ECONOMIZER OUTPUT	
PT21	PLUG-HEAT PUMP CONTROL	
PT22	PLUG-HEAT PUMP INPUT	
P145	PLUG-MOTOR PROTECTOR, COMP 2	
S4	SWITCH-LIMIT, HI PRESS, COMP 1	
S6	SWITCH-DEFROST, COMPRESSOR 1	
S7	SWITCH-LIMIT, HI PRESS, COMP 2	
S9	SWITCH-DEFROST, COMPRESSOR 2	
S11	SWITCH-LOW PRESS, LOW AMB KIT	
S42	OVERLOAD-RELAY, BLOWER MOTOR	
S46	SWITCH-DEFROST TERMINATION	
S48	SWITCH-DISCONNECT	
S49	SWITCH-FREEZE/STAT, COMP 1	

WARNING-ELECTRIC SHOCK HAZARD, CAN CAUSE INJURY OR DEATH. UNIT MUST BE GROUNDED IN ACCORDANCE WITH NATIONAL AND LOCAL CODES
 IF ANY WIRE IN THIS APPLIANCE IS REPLACED, IT MUST BE REPLACED WITH WIRE OF LIKE SIZE, RATING AND INSULATION THICKNESS
 LINE VOLTAGE FIELD INSTALLED NEC/CEC CLASS I
 NOTE-ALL REMAINING WIRES FACTORY INSTALLED
 DISCONNECT ALL POWER BEFORE SERVICING
 THERMOSTAT HEAT ANTICIPATION SETTING 0.1 AMP

NOTE-FOR USE WITH COPPER CONDUCTORS ONLY
 REFER TO UNIT RATING PLATE FOR MINIMUM CIRCUIT AMPACITY AND MAXIMUM OVERCURRENT PROTECTION SIZE

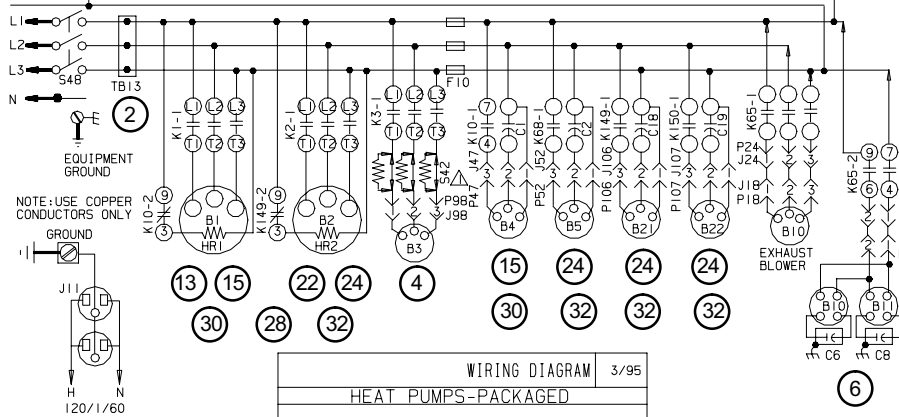

KEY	DESCRIPTION	COMPONENT
S50	SWITCH-FREEZE/STAT, COMP 2	
S84	SWITCH-LOW PRESS, LOW AMB COMP 2	
S87	SWITCH-LOW PRESS, COMP 1	
S88	SWITCH-LOW PRESS, COMP 2	
S104	SWITCH-DEFROST, COMP 2	
T1	TRANSFORMER-CONTROL	
TB13	TERMINAL STRIP-POWER DISTRIB	
TB34	TERMINAL STRIP-24VAC POWER	

△ S42 USED ON "M" VOLTAGE UNITS AND UNITS WITH HIGH EFFICIENCY MOTORS
 △ A9, A10, J81 AND P81 ARE USED ON -J VOLTAGE UNITS ONLY

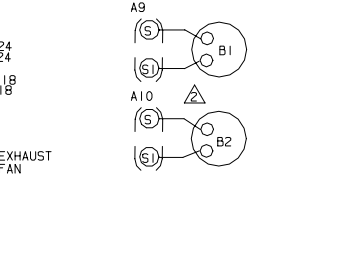

KEY	DESCRIPTION	COMPONENT
C19	CAPACITOR-OUTDOOR FAN 5	
C8B	CIRCUIT BREAKER-TRANS T1	
F10	FUSE-OUTDOOR FAN MOTOR	
HR1	HEATER-COMPRESSOR 1	
HR2	HEATER-COMPRESSOR 2	
J11	JACK-GFT RECEPTACLE	
J1B	JACK-PED	
J24	JACK-EXHAUST FAN	
J35	JACK-TEST, HEAT	
J36	JACK-TEST, COOL	
J47	JACK-OUTDOOR FAN 1	
J52	JACK-OUTDOOR FAN 2	
J81	JACK-MOTOR PROTECTOR, COMP 1	
J9B	JACK-BLOWER DECK	
J106	JACK-MOTOR, OUTDOOR FAN 3	
J107	JACK-MOTOR, OUTDOOR FAN 4	
J111	JACK-GAS 1 OUTPUT	
J112	JACK-COOLING SENSOR INPUT	
J113	JACK-BLOWER & COOL 1 CONTROL	
J114	JACK-SENSOR INPUT	
J115	JACK-ECONOMIZER OUTPUT	

WIRING DIAGRAM 3/95
 HEAT PUMPS-PACKAGED
 LHA-180,240-I-G,J,M,Y
 HEAT PUMP SECTION B15
 Supersedes Form No. New Form No.
 531,072W

©1995 Lennox Industries Inc. Litho U.S.A.

SEQUENCE OF OPERATION B15 DIAGRAM - LHA180/240 Y, G, J

Power:

- 1- Line voltage from TB2, unit disconnect S48, or other factory or field installed optional power disconnects, such as CB10, energizes transformer T1. Transformer T1 provides 24VAC power to terminal strip TB34, which provides 24VAC power to the unit cooling, heating, and blower controls and thermostat.
- 2- Terminal strip TB13 is also energized when the unit disconnect closes. TB13 supplies line voltage to compressor crankcase heaters, compressors, blower motors, and fan motors.

Blower Operation (OCP input must be on):

- 3- The main control module A55 receives a demand from thermostat terminal G. A55 energizes blower contactor K3 with 24VAC.
- 4- N.O. K3-1 closes, energizing blower B3.

Economizer Operation:

- 5- The economizer control module A56 receives a demand and energizes exhaust fan relay K65 with 24VAC at 50% (travel) outside air damper open (adjustable).
- 6- N.O. K65-1 and K65-2 both close, energizing exhaust fan motors B10 and B11.

First Stage Cooling Demand (compressors B1 is energized):

- 7- Cooling demand energizes G and Y1 in the thermostat. G energizes blower (see step 3).
- 8- 24VAC is routed through TB34 to the main control module A55.
- 9- A55 proves N.O. defrost switch S6 and N.C. defrost termination switch S46 to energize reversing valve L1 and low ambient relay K58.
- 10- N.C. contacts K58-1 open, giving control of K10 fan relay to low ambient pressure switch S11.
- 11- A55 proves N.C. low pressure switch S87, N.C. freezestat S49, and N.C. high pressure switch S4 to energize compressor contactor K1.
- 12- Compressor protector A9 may be installed on J voltage units only.
- 13- N.O. contacts K1-1 close energizing compressor B1.
- 14- 24VAC is routed through N.O. low ambient pressure switch S11 (now closed) and N.C. low ambient contact K58-1 (now open) to energize outdoor fan contactor K10.
- 15- N.O. contacts K10-1 close energizing outdoor fan B4 and N.C. contacts K10-2 open de-energizing compressor crankcase heater HR1.

Second Stage Cooling Demand (compressors B2 is energized):

- 16- Second stage cooling demand energizes Y2.
- 17- 24VAC is routed through TB34 to the heat pump control module A61.
- 18- A61 proves N.O. defrost switch S9 and N.C. defrost switch S104 to energize reversing valve L2 and low ambient relay K118.
- 19- N.C. contacts K118-1 open giving control of the K149 fan relay to the low ambient pressure switch S84.

20- A61 proves N.C. low pressure switch S88, N.C. freezestat S50, and N.C. high pressure switch S7 to energize compressor contactor K2.

21- Compressor protector A10 may be installed on J voltage units only.

22- N.O. contacts K2-1 close energizing compressor B2.

23- 24VAC is routed through N.O. low ambient pressure switch S84 (now closed) and N.C. low ambient contact K118-1 (now open) to energize outdoor fan relay K149.

NOTE: If the outdoor temperature is above the A55 and A61 TP2 setpoint, fan relays K68 and K150 are also energized.

24- N.O. contacts K68-1 close energizing outdoor fan B5. N.O. contacts K149-1 close energizing outdoor fan B21. N.C. contacts K149-2 open de-energizing compressor crankcase heater HR2, and N.O. contacts K150-1 close energizing outdoor fan B22.

First Stage Heating Demand (compressors B1 and B2 are energized):

25- Heating demand energizes W1 in the thermostat.

26- 24VAC is routed through TB34 to the main control module A55 and heat pump control module A61. After A55 and A61 proves N.C. low pressure switches S87 and S88, N.C. freezestat S49 and S50, and N.C. high pressure switch S4 and S7, compressor contactor K1 and K2 are energized.

NOTE: On first heating demand after unit has been in cooling mode, modules A55 and A61 will de-energize reversing valves L1 and L2, and low ambient relays K58 and K118. K58-1 and K118-1 N.C. contacts will take control away from low ambient pressure switches S11 and S84.

27- Compressor protector A9 and A10 are installed on J voltage units only.

28- N.O. contacts K1-1 and K2-1 close energizing compressors B1 and B2.

29- 24VAC from the main control module A55 is routed through the N.C. low ambient contact K58-1 to energize outdoor fan contactor K10.

30- N.O. contacts K10-1 close energizing outdoor fan B4 and N.C. contacts K10-2 open de-energizing compressor crankcase heater HR1.

31- 24VAC heat pump control module A61 is routed through N.C. low ambient contact K118-1 to energize outdoor fan contactor K149.

Second Stage Heating Demand (electric heat):

32- Second stage heating demand energizes W2 in the thermostat.

33- See sequence of operation for electric heat (diagrams A7 and A6).

NOTE: Outdoor fan contacts K68 and K150 are also energized through the A61 module. A55 and A61 TP2 setpoint is only in effect during cooling mode.

34- N.O. contacts K68-1 close energizing outdoor fan B5. N.O. contacts K149-1 close energizing outdoor fan B21. N.C. contacts K149-2 open de-energizing compressor crankcase heater HR2, and N.O. contacts K150-1 close energizing outdoor fan B22.

Defrost Mode: See Defrost Operation in Section I Unit Components-B Cooling Components.

GAS HEAT FOR LGA156/300

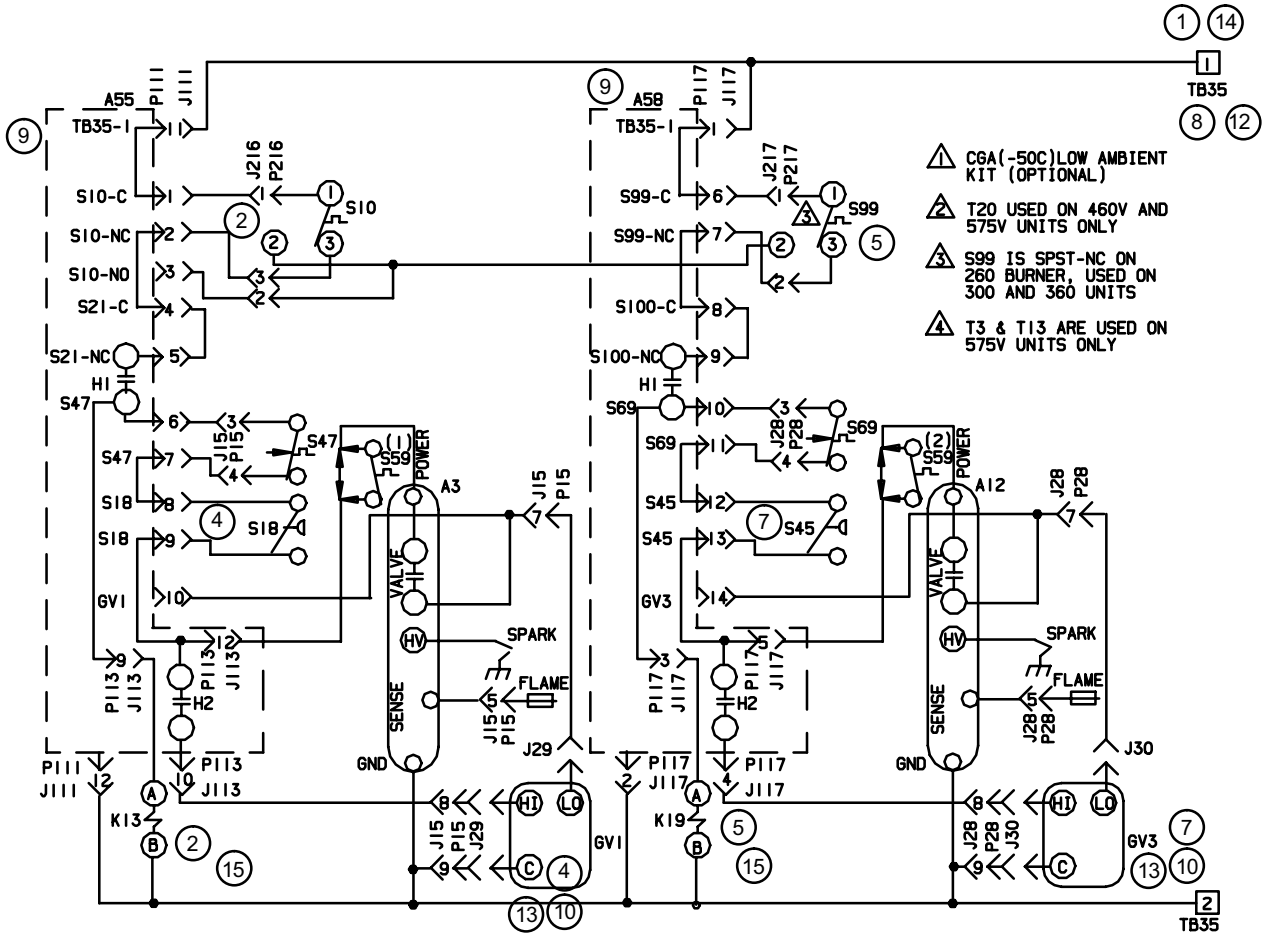

← DENOTES OPTIONAL COMPONENTS

KEY	DESCRIPTION	COMPONENT
A3	CONTROL - BURNER 1	
A12	CONTROL - BURNER 2	
A55	PANEL - MAIN	
A58	PANEL - GAS 2	
B6	MOTOR - COMBUSTION AIR BLOWER 1	
B15	MOTOR - COMBUSTION AIR BLOWER 2	
C3	CAPACITOR - COMB AIR BLOWER, MOTOR 1	
C11	CAPACITOR - COMB AIR BLOWER, MOTOR 2	
F20	FUSE, -50C LOW AMBIENT KIT	
GV1	VALVE - GAS 1	
GV3	VALVE - GAS 2	
HR6	HEATER, -50C LOW AMBIENT KIT	
J1	JACK - GAS LIMIT	
J13	JACK - GAS	
J15	JACK - GAS	
J28	JACK - ECONOMIZER PROGRAM	
J29	JACK - GAS 1	
J30	JACK - GAS 2	
J111	JACK - GAS 1, OUTPUT	
J113	JACK - BLOWER & COOL 1 CONTROL	
J117	JACK - GAS 2 CONTROL	
J216	JACK - PRIMARY LIMIT 1	
J217	JACK - PRIMARY LIMIT 2	
K13, -1	RELAY - COMBUSTION AIR BLOWER	
K19, -1	RELAY - STAGE 2, HEAT	
P1	PLUG - GAS LIMIT	
P13	PLUG - GAS	
P15	PLUG - GAS	
P28	PLUG - ECONOMIZER PROGRAM	
P111	PLUG - GAS 1, OUTPUT	
P113	PLUG - BLOWER & COOL 1 CONTROL	
P117	PLUG - GAS 2 CONTROL	
P216	PLUG - PRIMARY LIMIT 1	
P217	PLUG - PRIMARY LIMIT 2	
S10	SWITCH - LIMIT, PRIMARY GAS	
S18	SWITCH - COMB AIR BLOWER, PROVE	
S45	SWITCH - LIMIT, COMB AIR BWR, PROVE 2	
S47	SWITCH - FLAME ROLLOUT, BURNER 1	

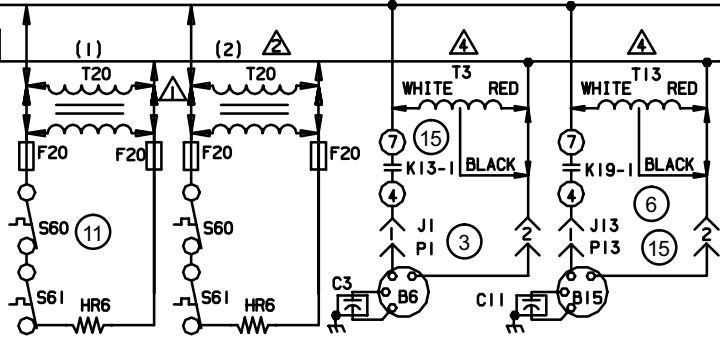

KEY	DESCRIPTION	COMPONENT
S59	THERMOSTAT, -35 C OPEN, -50 C	
S60	THERMOSTAT, -23C CL, -7C OP, -50C LOW AMB KIT	
S61	THERMOSTAT, +24C OPEN, -50C LOW AMB KIT	
S69	SWITCH - FLAME ROLLOUT 2	
S99	SWITCH - LIMIT, PRIMARY BURNER 2	
T3	TRANSFORMER - COMB AIR BLOWER 1	
T13	TRANSFORMER - COMB AIR BLOWER 2	
T20	TRANSFORMER, -50C LOW AMBIENT KIT	
TB35	TERMINAL STRIP - TRANS T1	

WIRING DIAGRAM	4/04
COMBINATION UNIT-ROOFTOP	
GAS HEAT FOR	
"L" SERIES, 260, 360 AND 480 UNITS	
(C & D BOX)	
HEATING SECTION-A2	
Supersedes Form No.	New Form No.
534, 443W	534, 658W

SEQUENCE OF OPERATION

A2 DIAGRAM - GAS HEAT FOR "L" SERIES, 260 AND 470 UNITS

FIRST STAGE HEAT:

- 1 - Heating demand initiates at W1 in thermostat.
- 2 - 24VAC is routed through TB35 to the main control module A55. After A55 proves N.C. primary limit S10 and N.C. secondary limit S21 the combustion air blower relay K13 is energized.
- 3 - N.O. K13-1 contacts close allowing line voltage (or transformer T3 in 460V and 575V only) to energize combustion air blower B6.
- 4 - After the combustion air blower B6 has reached full speed, the combustion air proving switch (S18) contacts close. The A55 routes 24VAC through N.C. burner 1 flame rollout switch S47 and the closed contacts of the combustion air proving switch (S18) to energize the ignition module A3. After a 30 second delay A3 energizes the W1 terminal (low fire) of gas valve GV1.
- 5 - As steps 2, 3 and 4 occur, 24VAC is also routed to the gas valve control module A58. After A58 proves N.C. primary gas heat limit S99 and N.C. secondary limit S100 the combustion air blower relay K19 is energized.
- 6 - N.O. K19-1 contacts close allowing line voltage (or transformer T13 in 460V and 575V only) to energize combustion air blower B15.
- 7 - After the combustion air blower B15 has reached full speed, the combustion air proving switch (S45) contacts close. The A58 routes 24VAC through N.C. burner 2 flame rollout switch S69 and the closed contacts of the combustion air proving switch (S45) to energize the ignition module A12. After a 30 second delay A12 energizes the W1 terminal (low fire) of gas valve GV3.

SECOND STAGE HEAT:

- 8 - With first stage heat operating, an additional heating demand initiates W2 in the thermostat.
- 9 - A second stage heating demand is received by both A55 and A58 modules.
- 10 - Each module will energize the corresponding W2 terminal (high fire) of gas valves GV1 and GV3 respectively.

OPTIONAL LOW AMBIENT KIT (C.G.A. -50°C LOW AMBIENT KIT):

- 11 - Line voltage (or transformer T20 in 460V and 575V only) is routed through the low ambient kit fuses F20 and N.C. low ambient kit thermostats S60 and S61 to energize low ambient kit heater HR6.

END OF SECOND STAGE HEAT:

- 12 - Heating demand is satisfied. Terminal W2 is de-energized.
- 13 - Terminals W2 (high fire) of GV1 and GV3 are de-energized by the A55 and A58 Module.

END OF FIRST STAGE HEAT:

- 14 - Heating demand is satisfied. Terminal W1 is de-energized.
- 15 - Ignition module A3 is de-energized by A55 in turn de-energizing terminal W1 of GV1. Combustion blower relay K13 is also de-energized. At the same instant, ignition module A12 is de-energized by A58 module in turn de-energizing the W1 terminal of GV3. K19 combustion air blower relay is also de-energized.

A7 diagram EHA-15, 30, 45, 60, 90 - Y

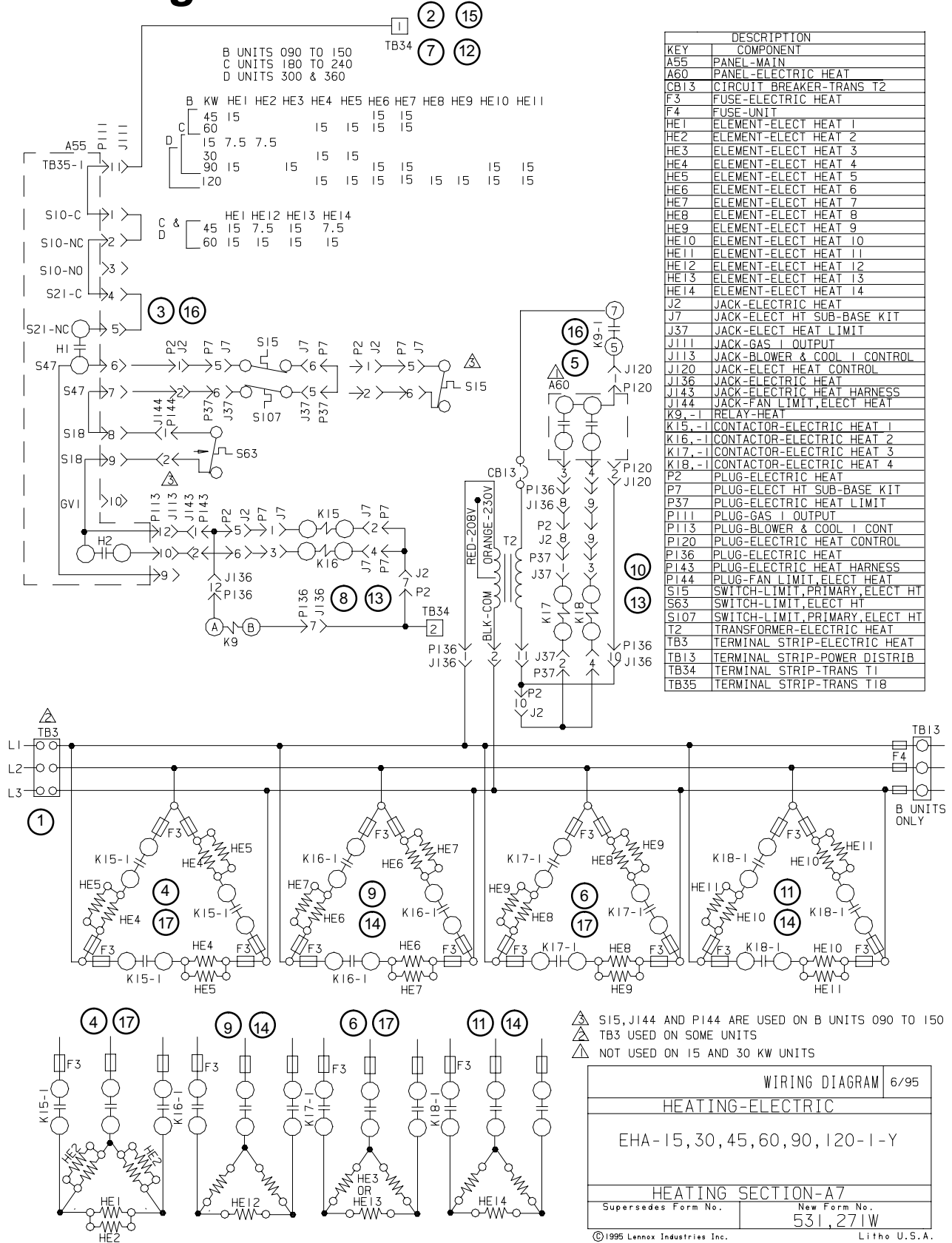

WIRING DIAGRAM	6/95
HEATING-ELECTRIC	
EHA-15, 30, 45, 60, 90, 120-I-Y	
HEATING SECTION-A7	
Supersedes Form No.	New Form No.
	531, 271W

©1995 Lennox Industries Inc. Litho U.S.A.

SEQUENCE OF OPERATION
A7 DIAGRAM - EHA-15, 30, 45, 60, 90 - Y
A6 DIAGRAM - EHA-15, 30, 45, 60, 90 - G, J

Diagrams A7 and A6 are the EHA electric heat sections used in the LHA and LCA units. The Y voltage diagram (A7) use elements configured in a Wye. The G and J voltage diagram (A6) use elements configured in a Delta. Both diagrams A7 and A6 follow the following sequence of operation:

NOTE: Two electric heat sections are used in all 15kW through 90kW heaters. The heat sections are labelled first electric heat section (left side) and second electric heat section (right side). See figure 27.

NOTE: In the case of EHA 15 and 30kW, the second heat section (right side) is a slave (only has electric heat elements and a limit). In this case the A60 module, T2 transformer, and K9 heat relay are not used. Line voltage is supplied to elements in both heat section one (left side) and two (right side) by the contactors in heat section one (left side) and all control is through the A55 module.

HEATING ELEMENTS:

- 1 - Terminal strip TB3 is energized when the unit disconnect closes. TB3 supplies line voltage to electric heat elements HE1 through HE14. Each heating element is protected by fuse F3.

FIRST STAGE HEAT:

- 2 - Heating demand initiates at W1 in thermostat.
- 3 - 24VAC is routed through TB34 to the main control module A55. After A55 proves N.C. primary limits S15 (heat section one, left side), S107 (heat section two, right side), and redundant electric heat limit S63, the electric heat contactor K15 and heat relay K9 are energized.
- 4 - N.O. contact K15-1 closes allowing the first bank of elements in heat section one (left side) to be energized.
- 5 - At the same time, line voltage is routed through transformer T2, which provides 24VAC to the electric heat control module A60. A60 is energized when N.O. contacts K9-1 close. A N.O. contact in A60 closes, energizing electric heat relay K17.

- 6 - N.O. contacts K17-1 close allowing the first set of elements in heat section two (right side) to be energized.

SECOND STAGE HEAT:

- 7 - With the first stage heat operating, an additional heating demand initiates at W2 in the thermostat.
- 8 - 24VAC is routed through the main control module A55, which in turn energizes the electric heat contactor K16.
- 9 - N.O. contacts K16-1 close allowing the second set of elements in heat section one (left side) to be energized.
- 10 - Simultaneous with step eight, a N.O. contact in the electric heat control module A60 closes, allowing 24VAC to energize electric heat contactor K18.
- 11 - N.O. contacts K18-1 close allowing the second set of elements in heat section two (right side) to be energized.

END OF SECOND STAGE HEAT:

- 12 - Heating demand is satisfied. Terminal W2 in the thermostat is de-energized.
- 13 - Electric heat contactors K16 and K18 are de-energized.
- 14 - The second set of electric heat elements in heat sections one (left side) and two (right side) are de-energized.

END OF FIRST STAGE HEAT:

- 15 - Heating demand is satisfied. Terminal W1 in the thermostat is de-energized.
- 16 - Electric heat contactors K15 and K17 are de-energized.
- 17 - The first set of electric heat elements in heat sections one (left side) and two (right side) are de-energized.

A6 diagram EHA-15, 30, 45, 60, 90 - G, J

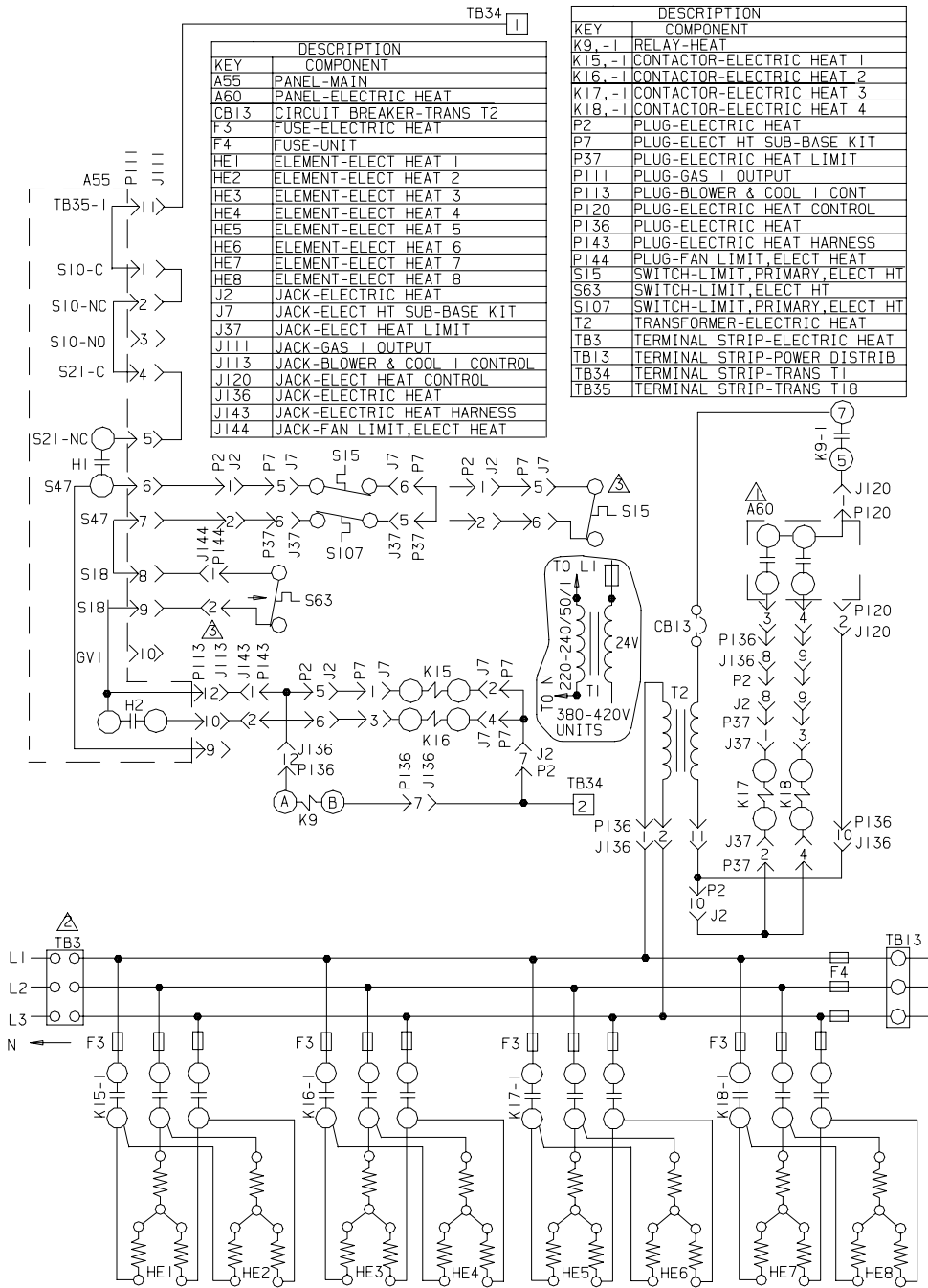

KEY	DESCRIPTION
A55	PANEL-MAIN
A60	PANEL-ELECTRIC HEAT
CB13	CIRCUIT BREAKER-TRANS T2
F3	FUSE-ELECTRIC HEAT
F4	FUSE-UNIT
HE1	ELEMENT-ELECT HEAT 1
HE2	ELEMENT-ELECT HEAT 2
HE3	ELEMENT-ELECT HEAT 3
HE4	ELEMENT-ELECT HEAT 4
HE5	ELEMENT-ELECT HEAT 5
HE6	ELEMENT-ELECT HEAT 6
HE7	ELEMENT-ELECT HEAT 7
HE8	ELEMENT-ELECT HEAT 8
J2	JACK-ELECT HT SUB-BASE KIT
J7	JACK-ELECT HT SUB-BASE KIT
J37	JACK-ELECT HEAT LIMIT
J111	JACK-GAS I OUTPUT
J113	JACK-BLOWER & COOL I CONTROL
J120	JACK-ELECT HEAT CONTROL
J136	JACK-ELECTRIC HEAT
J143	JACK-ELECTRIC HEAT HARNESS
J144	JACK-FAN LIMIT, ELECT HEAT

KEY	DESCRIPTION
K9 -1	RELAY-HEAT
K15 -1	CONTACTOR-ELECTRIC HEAT 1
K16 -1	CONTACTOR-ELECTRIC HEAT 2
K17 -1	CONTACTOR-ELECTRIC HEAT 3
K18 -1	CONTACTOR-ELECTRIC HEAT 4
P2	PLUG-ELECTRIC HEAT
P7	PLUG-ELECT HT SUB-BASE KIT
P37	PLUG-ELECTRIC HEAT LIMIT
P111	PLUG-GAS I OUTPUT
P113	PLUG-BLOWER & COOL I CONT
P120	PLUG-ELECTRIC HEAT CONTROL
P136	PLUG-ELECTRIC HEAT
P143	PLUG-ELECTRIC HEAT HARNESS
P144	PLUG-FAN LIMIT, ELECT HEAT
S15	SWITCH-LIMIT, PRIMARY, ELECT HT
S63	SWITCH-LIMIT, ELECT HT
S107	SWITCH-LIMIT, PRIMARY, ELECT HT
T2	TRANSFORMER-ELECTRIC HEAT
TB3	TERMINAL STRIP-ELECTRIC HEAT
TB13	TERMINAL STRIP-POWER DISTRIB
TB34	TERMINAL STRIP-TRANS T1
TB35	TERMINAL STRIP-TRANS T18

▲ S15, J144 AND P144 ARE USED ON B UNITS 090 TO 150
 ▲ TB3 IS USED ON SOME UNITS
 ▲ NOT USED ON 15 AND 30KW UNITS

	B	C	D	KW	HE1	HE2	HE3	HE4	HE5	HE6	HE7	HE8
B	45	15	15	15	15	15	15	15	15	15	15	15
C	60	15	15	15	15	15	15	15	15	15	15	15
D	15	7.5	7.5	7.5	7.5	7.5	7.5	7.5	7.5	7.5	7.5	7.5
	30	15	15	15	15	15	15	15	15	15	15	15
	45	15	15	15	15	15	15	15	15	15	15	15
	60	15	15	15	15	15	15	15	15	15	15	15
	90	15	15	15	15	15	15	15	15	15	15	15
	120	15	15	15	15	15	15	15	15	15	15	15

WIRING DIAGRAM		6/95
HEATING-ELECTRIC		
EHA-15, 30, 45, 60, 90, 120-1-G, J, M		
HEATING SECTION-A6		
Supersedes Form No.	New Form No.	
	531, 270W	

©1995 Lennox Industries Inc. Litho U.S.A.

C2 diagram ELECTRONIC OR ELECTROMECHANICAL THERMOSTAT

24V POWER

①

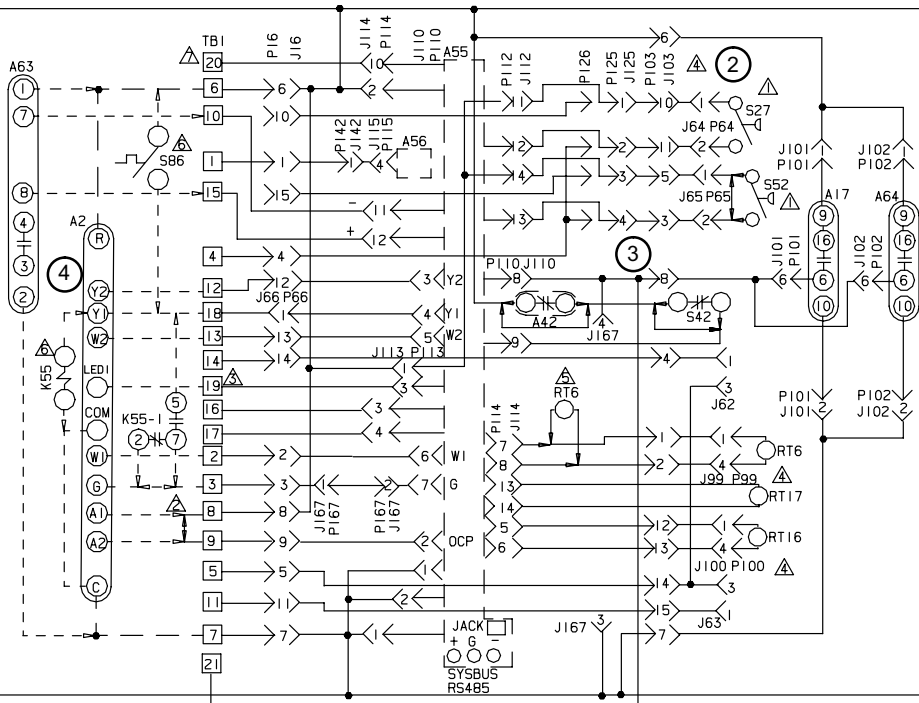

24V COMMON

KEY	DESCRIPTION
A2	SENSOR-ELECTRONIC
A17	DETECTOR-SMOKE
A42	MONITOR-PHASE PROTECTION
A55	PANEL-MAIN
A56	PANEL-ECONOMIZER
A63	SENSOR-CO2 (IAQ)
A64	DETECTOR-SMOKE, SUPPLY AIR
J16	JACK-UNIT
J62	JACK-A2 RETURN AIR SENSOR
J63	JACK-RT1 DISCH. AIR SENSOR
J64	JACK-S27 FILTER SWITCH
J65	JACK-S52 FAN SWITCH
J66	JACK-COOL I INTERFACE
J99	JACK-DISCHARGE TEMP SENSOR
J100	JACK-RETURN TEMP SENSOR
J101	JACK-SMOKE DETECTOR, RETURN AIR
J102	JACK-SMOKE DETECTOR, SUPPLY AIR
J103	JACK-SENSORS, CONTROL
J110	JACK-THERMOSTAT INPUT
J112	JACK-COOLING SENSOR INPUT
J113	JACK-BLOWER & COOL I CONTROL
J114	JACK-SENSOR INPUT
J115	JACK-ECONOMIZER OUTPUT
J125	JACK-BLOWER PROVING
J126	JACK-JUMPER, BLOWER PROVING
J142	JACK-ECONOMIZER HARNESS
J167	JACK-BLOWER OVERRIDE, STD
K27	RELAY-TRANSFER 2
K55	RELAY-BLOWER
P16	PLUG-UNIT
P64	PLUG-S27 FILTER SWITCH
P65	PLUG-S50 FAN SWITCH
P66	PLUG-COOL ONE
P99	PLUG-DISCHARGE TEMP SENSOR
P100	PLUG-RETURN TEMP SENSOR
P101	PLUG-SMOKE DETECTOR, RETURN AIR
P102	PLUG-SMOKE DETECTOR, SUPPLY AIR

KEY	DESCRIPTION
P103	PLUG-SENSORS, CONTROL
P110	PLUG-THERMOSTAT INPUT
P112	PLUG-COOLING SENSOR INPUT
P113	PLUG-BLOWER & COOL I CONTROL
P114	PLUG-SENSOR INPUT
P115	PLUG-ECONOMIZER OUTPUT
P125	PLUG-BLOWER PROVING
P126	PLUG-JUMPER, BLOWER PROVING
P142	PLUG-ECONOMIZER HARNESS
P167	PLUG-BLOWER OVERRIDE, STD
RT6	SENSOR-A55 DISCHARGE (IMC)
RT16	SENSOR-RETURN AIR TEMP
RT17	SENSOR-OUTSIDE AIR TEMP
S27	SWITCH-FILTER
S42	OVERLOAD-RELAY, BLOWER MOTOR
S52	SWITCH-AIR FLOW
S86	SWITCH-DEHUMIDISTAT 65F8601
TB1	TERMINAL STRIP-24V CLASS II



THERMOSTAT HOOKUP FOR SELECTABLE OPTION #3, ECTO 5.04 ON M1-5 IMC BOARD (A55)

TO PROVIDE THREE COMPRESSOR STAGES. REQUIRES 3 HEAT, 3 COOL THERMOSTAT AND K27 RELAY

- ⚠ S27 and S52 are optional
- ⚠ REMOVE JUMPER WHEN OCCUPIED-UNOCCUPIED OPERATION IS DESIRED. UNIT REMAINS IN OCCUPIED OPERATION WITH JUMPER
- ⚠ TB1-19 IS SERVICE RELAY OUTPUT (24VAC). IF USED CONNECT TO A INDICATOR LIGHT OR RELAY COIL (MAX 4VA)
- ⚠ J99/P99, J100/P100 AND J103/P103 ARE NOT USED ON-036, 042, 048, 060, 072, 088 AND 100 UNITS
- ⚠ ALTERNATE REMOTE LOCATION OF RT6
- ⚠ USE S86 DEHUMIDISTAT AND K55 RELAY FOR OPTIONAL REHEAT SCHEME. SET PARAMETER 4.24 TO CONTROL VALVE I FOR SIMULTANEOUS HEATING AND COOLING
- ⚠ TB1-20 FOR DEHUMIDIFICATION CONTROL

————— DESIGNATES OPTIONAL WIRING
- - - - - CLASS II FIELD WIRING

WIRING DIAGRAM 1/01	
ACCESSORIES	
ELECTRONIC OR ELECTROMECHANICAL THERMOSTAT FOR "L" SERIES UNITS	
TEMPERATURE CONTROL SECTION C2	
Supersedes Form No. 532, 583W	New Form No. 533, 629W
© 2001 Litho U.S.A.	

SEQUENCE OF OPERATION

C2 DIAGRAM - ELECTRONIC OR ELECTROMECHANICAL THERMOSTAT

POWER:



1 - Terminal strip TB34 energizes the thermostat components with 24VAC via TB1.

OPERATION:

- 2 - The main control module A55 proves the optional N.O. filter switch S27(indicates dirty filter when closed), optional N.O. air flow switch S52(indicates no air [i.e. broken belt] system shuts down), and optional C.G.A. -50°C low ambient kit thermostat S59 (used in C.G.A. units only).
- 3 - The main control module A55 receives data from the supply and return smoke detectors A17 and A64, optional phase protection monitor A42, blower motor overload relay S42, discharge sensor RT6, return air sensor RT16, and the outdoor air sensor RT17.
- 4 - The main control module A55 receives data from the electronic thermostat A2 (Y1, Y2, W1, W2, G, OCP) and the CO₂ sensor (if economizer is used) via terminal strip TB1. A55 energizes the appropriate components.

D1 diagram "L" SERIES ECONOMIZER

DESCRIPTION	
KEY	COMPONENT
A7	SENSOR-SOLID STATE ENTHALPY
A56	PANEL-ECONOMIZER
A62	SENSOR-ENTHALPY, INDOOR
B7	MOTOR-DAMPER
J3	JACK-UNIT ECONOMIZER
J104	JACK-SENSOR, OUTDOOR ENTHALPY
J105	JACK-SENSOR, RETURN AIR ENTHALPY
J115	JACK-ECONOMIZER, OUTPUT
P3	PLUG-UNIT ECONOMIZER
P104	PLUG-SENSOR, OUTDOOR ENTHALPY
P105	PLUG-SENSOR, RETURN AIR ENTHALPY
P115	PLUG-ECONOMIZER, OUTPUT
TB34	TERMINAL STRIP-TRANSFORMER T1

-  DELETE A7 AND A62 (IF USED) FOR EITHER GLOBAL ENTHALPY OR SENSIBLE TEMPERATURE CONTROL
-  FOR UNIT DIFFERENTIAL ENTHALPY CONTROL, ADD A62 RETURN AIR ENTHALPY SENSOR

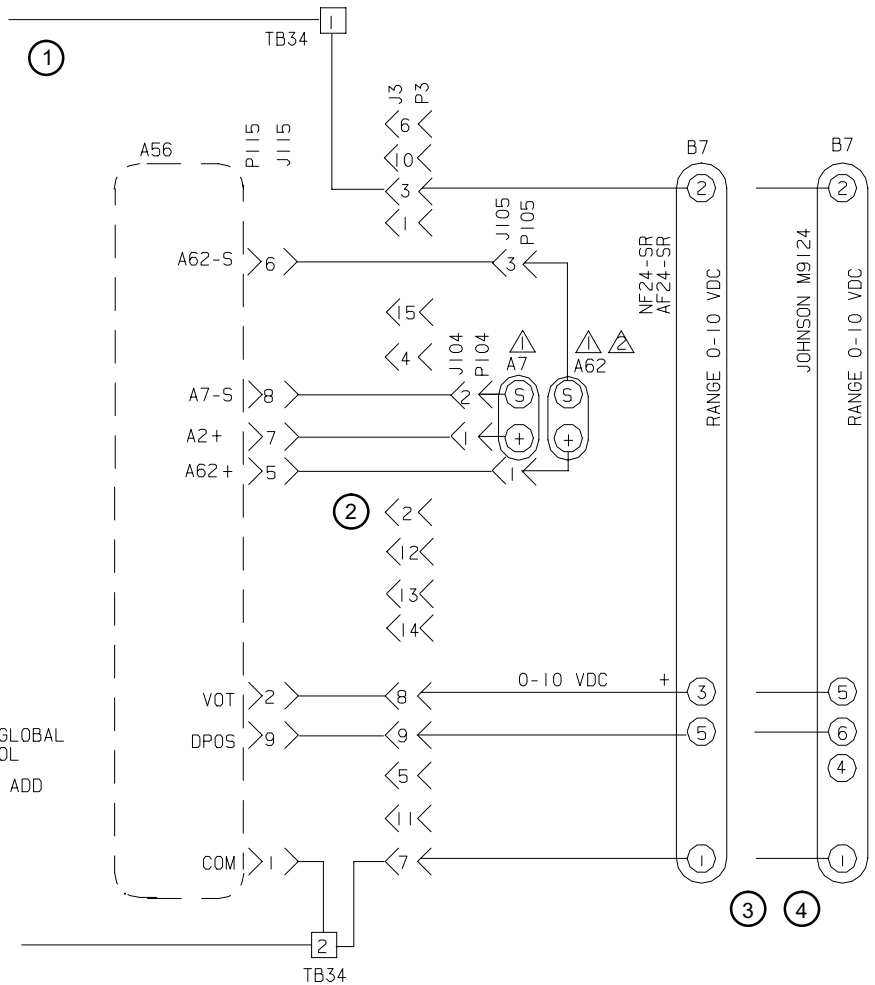

NOTE: THIS DIAGRAM USED ONLY WHEN ECONOMIZER OR MOTORIZED OUTDOOR AIR DAMPERS ARE INSTALLED

WIRING DIAGRAM		5/95
ACCESSORIES		
"L" SERIES ECONOMIZER AND MOTORIZED OUTSIDE AIR DAMPER		
ECONOMIZER-SECTION D1		
Supersedes Form No.	New Form No.	
	531,285W	

©1995 Lennox Industries Inc.

Litho U S.A.

SEQUENCE OF OPERATION D1 DIAGRAM - "L" SERIES ECONOMIZER

POWER:

1 - Terminal strip TB34 energizes the economizer components with 24VAC.

OPERATION:

- 2 - The main control module A55 along with outdoor enthalpy sensor A7 and indoor enthalpy sensor A62 (if differential enthalpy is used) communicates to the economizer control module A56 when to power the damper motor B7.
- 3 - The economizer control module A56 supplies B7 with 0 - 10 VDC to control the positioning of economizer.
- 4 - The damper actuator provides 2 to 10 VDC position feedback.