

**GUIDE TO THE M1-7 VERSION 5.02 INTEGRATED MODULAR
CONTROL USED IN L SERIES® AND S-CLASS™ 3 THROUGH 50 TON UNITS**

IMPORTANT: This manual is for use with IMC board M1-7 version 5.02 only. Check IMC software version as shown in figure 11 to be sure the IMC version is 5.02.

Table Of Contents

Abbreviations	Page 119	Networking	Page 86
Alarms	Page 11	Outdoor Air CFM Control	Page 59
BACnet™ Module	Page 78	PID Loop Operation	Page 26
Code Conversion	Page 110	Power Exhaust Operation	Page 43
Configuration Data	Page 7	Reheat	Page 28
Demand Control Ventilation	Page 58	Sensors	Page 70
DIP Switch Settings	Page 4	Service Output	Page 62
Discharge Air Control	Page 36	Service Relay Operation	Page 62
Displaying Sensor Readings	Page 67	Smoke Detector Options	Page 48
Economizer	Page 52	Software Version	Page 6
ECTO Electronic Configure To Order Control	Page 85	Start-Up	Page 9
Fresh Air Tempering	Page 34	Summary Sheet	Page 120
General Purpose GP1 Board	Page 7	Supply Air Delivery	Page 23
IMC Components	Page 4	Testing Unit Function	Page 64
Inputs and Outputs	Page 110	Thermostat Simulation Test	Page 66
Load Shedding Options	Page 42	Third Party Zoning	Page 72
LonTalk™ Module	Page 81	Unit Component Operation	Page 46
Low Ambient Fan Cycling	Page 50	Unit Field Wiring	Page 10
Main Control Operation	Page 16	Unit Start-Up	Page 9
Modulating Gas Valve (MGV)	Page 42	Zoning	Page 72

The Integrated Modular Control (IMC) is a series of control boards that make up the unit controller in the L Series and S-Class rooftop units. The IMC provides all control functions for the unit, insuring safe and reliable operation. Unit status information and unit diagnostics are also provided by the IMC to facilitate troubleshooting. Although default operation doesn't require programming, the IMC has programmable control parameters that allow adjustment of time delays and setpoints that enable many advanced features.

The default operation requires a standard room thermostat or direct digital controller (DDC). By changing one parameter, the IMC will also control the unit from a zone sensor. In addition to being the



unit controller, the IMC is also a network controller when daisy-chained to the L Connection® Network. For ease of configuration, the IMC can be connected to a PC which has been loaded with Unit Controller software.

The M1 main control board is provided on all L Series and S-Class units. Add-on boards are plugged into the main board to build variations according to application or equipment type. The M1 control wiring diagram key number is A55.

Table 1 shows which IMC control boards are provided in each unit. Figure 1 shows the M1 control location in each unit. Figure 2 shows the location of the add-on boards in relation to the main control board.

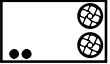

**TABLE 1
IMC BOARDS BY UNIT**

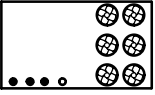
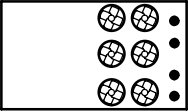
Box Size & Footprint	Packaged Unit	Expansion Boards								
		Main	#2 Compressor	#3 & 4 Compressors	#2 Electric Heat Section	#2 Gas Heat Section	#2 Compressor & Rev. Valve	Economizer	Humiditrol Reheat	VAV, Mod. Gas Valve, and/or Gen. Purpose
		A55 M1	A57 C1	A59 C2	A60 E1	A58 G1	A61 HP1	A56 EM1	A67 RH1	*A133 GP1
<p align="center">A</p> 	Gas / Electric & Electric / Electric 036, 042, 048, 060, 072 (3, 3.5, 4, 5, & 6 Ton)	M1						OPT	OPT	OPT
	Gas / Electric & Electric / Electric 090, 102, 120, 150 (7.5, 8.5, 10, 12.5 Ton)	M1	C1					OPT	OPT	OPT
<p align="center">B</p> 	Heat Pump 090, 102, 120, 150 (7.5, 8.5, 10, 12.5 Ton)	M1					HP1	OPT		OPT
	Gas / Electric & Electric / Electric 156, 180, 210, 240, 300S (13, 15, 18.5, 20 & 25 Ton)	M1	C1	C2		G1		OPT	OPT	OPT
	Electric / Electric 156, 180, 210, 240, 300S (13, 15, 18.5, 20, 25 Ton)	M1	C1	C2	OPT				OPT	OPT
<p align="center">C</p> 	Heat Pump 180 & 240 (15, 20 Ton)	M1			OPT		HP1	OPT		OPT
	Gas / Electric 300 & 360 (25 & 30 Ton)	M1	C1	C2		G1		OPT	OPT	OPT
	Electric / Electric 300H & 360 (25 & 30 Ton)	M1	C1	C2	OPT				OPT	OPT
<p align="center">D</p> 	Gas / Electric 420, 480, 540, 600 (35, 40, 45, 50 Ton)	M1	C1	C2		G1		OPT	OPT	OPT
	Electric / Electric 420, 480, 540, 600 (35, 40, 45, 50 Ton)	M1	C1	C2	OPT				OPT	OPT
<p align="center">E</p> 	Gas / Electric 420, 480, 540, 600 (35, 40, 45, 50 Ton)	M1	C1	C2		G1		OPT	OPT	OPT
	Electric / Electric 420, 480, 540, 600 (35, 40, 45, 50 Ton)	M1	C1	C2	OPT				OPT	OPT

*Up to three A133 General Purpose boards can be used. Each board must be set to a different mode.

An optional A138 FS1 board adds Y3, Y4, W3, and W4 24VAC inputs. This board is only required for applications with a 4-stage thermostat or DDC.

A55 (M1) MAIN CONTROL PANEL LOCATION BY UNIT

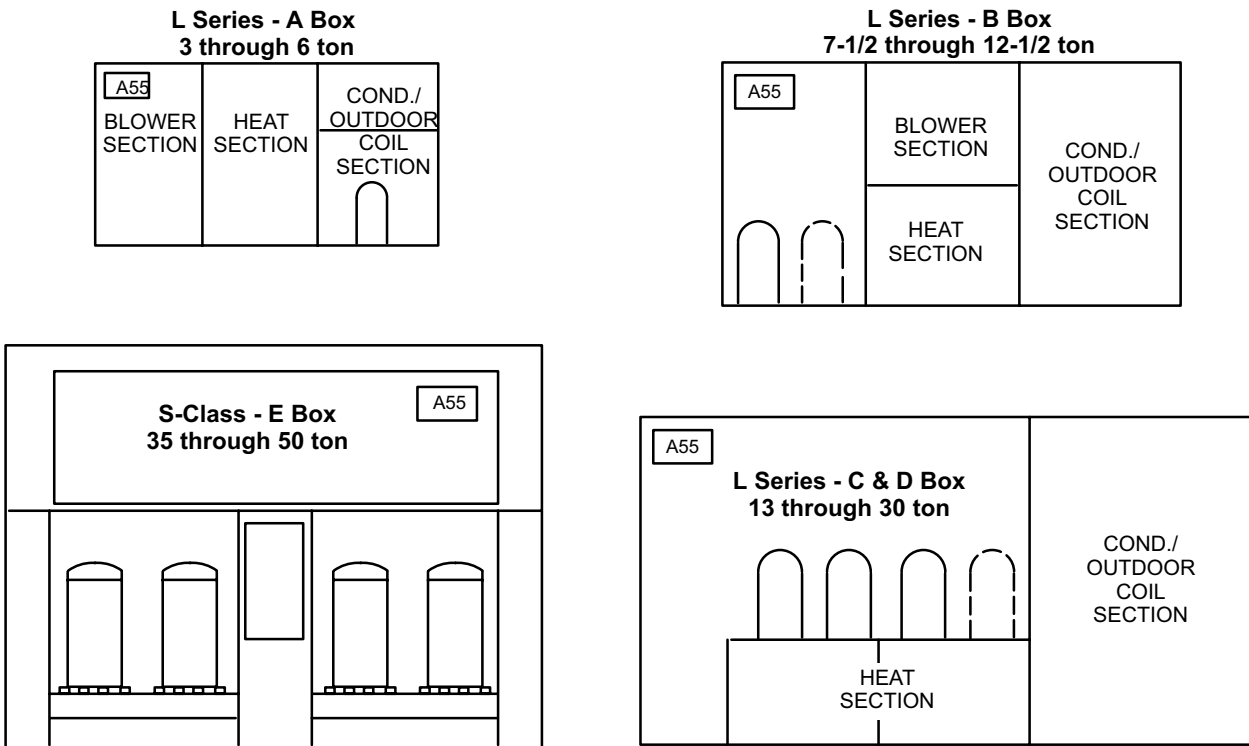

FIGURE 1

IMC AND EXPANSION BOARD LOCATION AND OPERATION

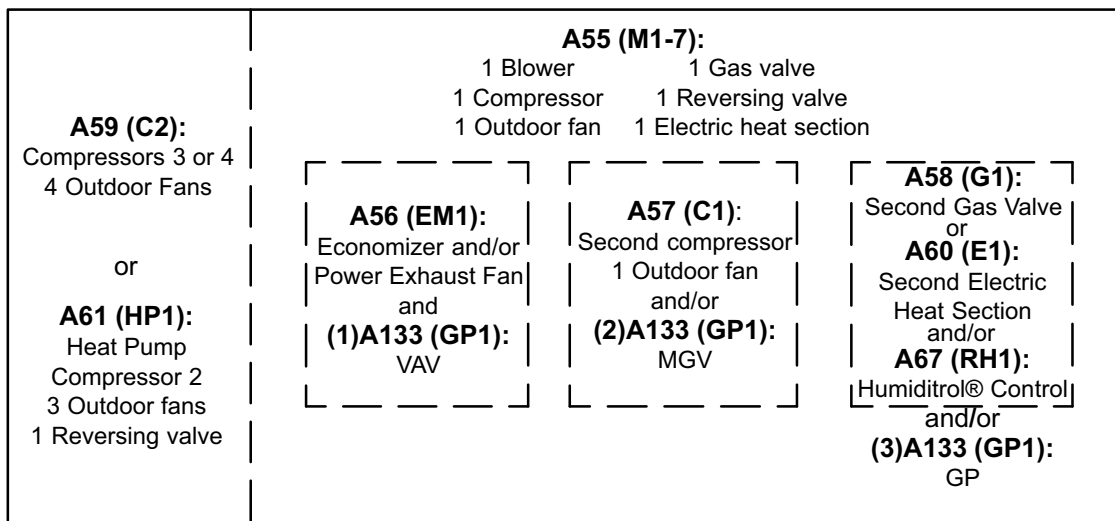

FIGURE 2

IMC Components

LED READOUT

On unit power-up the A55 M1-7 board LED readout will display "8.8.8." for 8 seconds and turn off. Confirm that all segments of the LED are functioning.

The readout will display error codes if present. Refer to the Diagnostics section. The readout will also indicate "LAL" if any compressors are in low ambient lockout and "LS" if the unit is functioning in load shedding mode. The readout displays additional information when used with the pushbutton and DIP switch settings as shown throughout this manual.

RESETTING THE CONTROL

Reset the M1 control with the pushbutton located to the right of the LED readout. Hold down the pushbutton for at least three seconds to reset the M1 control. The LED readout will display "8.8.8.", flash several times, and turn off.

HEARTBEAT LED

Each control board has a green flashing "heartbeat" LED. The heartbeat LED will flash indicating normal operation. See table 2 for an explanation of heartbeat LED operation.

**TABLE 2
HEARTBEAT LED OPERATION**

HEARTBEAT LED STATUS	A55 (M1) BOARD	ADD-ON BOARDS
FLASHING	NORMAL OPERATION	NORMAL OPERATION
*FLICKERING	N/A	CHECK ELECTRICAL CONNECTIONS
STEADY OFF	NO VOLTAGE TO M1 BOARD; SEE FIGURE 3	NO VOLTAGE TO M1 BOARD; SEE FIGURE 3
STEADY ON	DEFECTIVE BOARD (REPLACE)	DEFECTIVE BOARD (REPLACE)

*A "FLICKERING" LED WILL FLASH SIGNIFICANTLY FASTER THAN THE A55 HEARTBEAT LED.

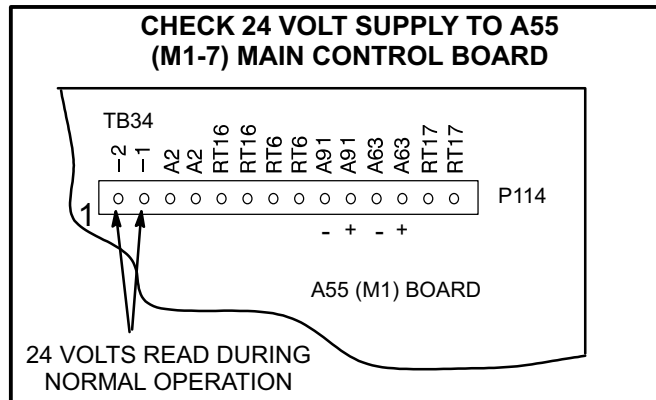

FIGURE 3

THERMOSTAT INPUT INDICATING LED'S

Thermostat input indicating LED's are located on the M1-7 board above P110 connector. **LED'S indicate a thermostat demand only.** See figure 4.

IMPORTANT - Check DIP switches BEFORE applying power to unit. The M1 checks switch position on power-up and after a reset.

THERMOSTAT INPUT INDICATING LED'S	
G	- Blower on
W1	- First stage heat
W2	- Second stage heat
Y1	- First stage cool
Y2	- Second stage cool
OCP	- Occupied
NOTE - LED's are energized by 24 vac thermostat inputs. Disregard LED's when A138 FS1 board is used.	

FIGURE 4

NETWORK LED'S

NETWORK LED'S	
BUS ○	Indicates network traffic.
XMIT ○	Indicates the IMC is transmitting data.

FIGURE 5

DIP SWITCH SETTINGS

DIP switches must be set correctly for proper unit operation. Refer to figures 6, 7, 9, 8, and 10 to check DIP switch settings. DIP switches are particular to each type of unit - not all switches shown in this manual will be in all units.

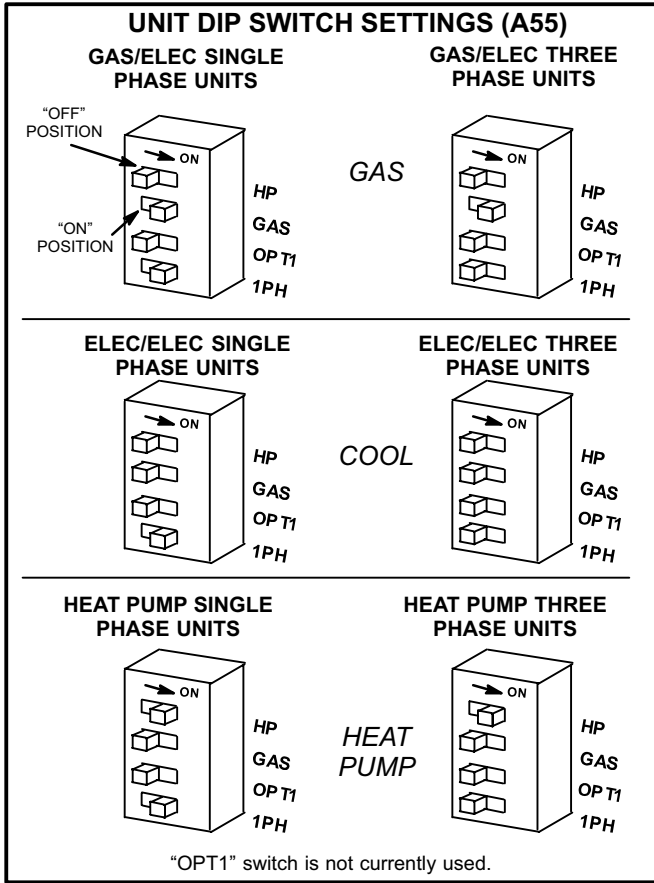

FIGURE 6

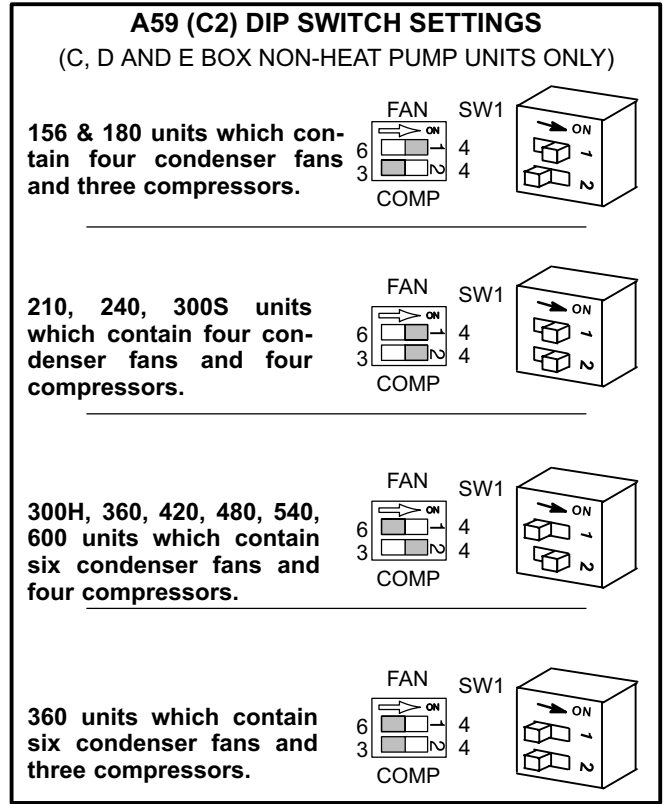

FIGURE 7

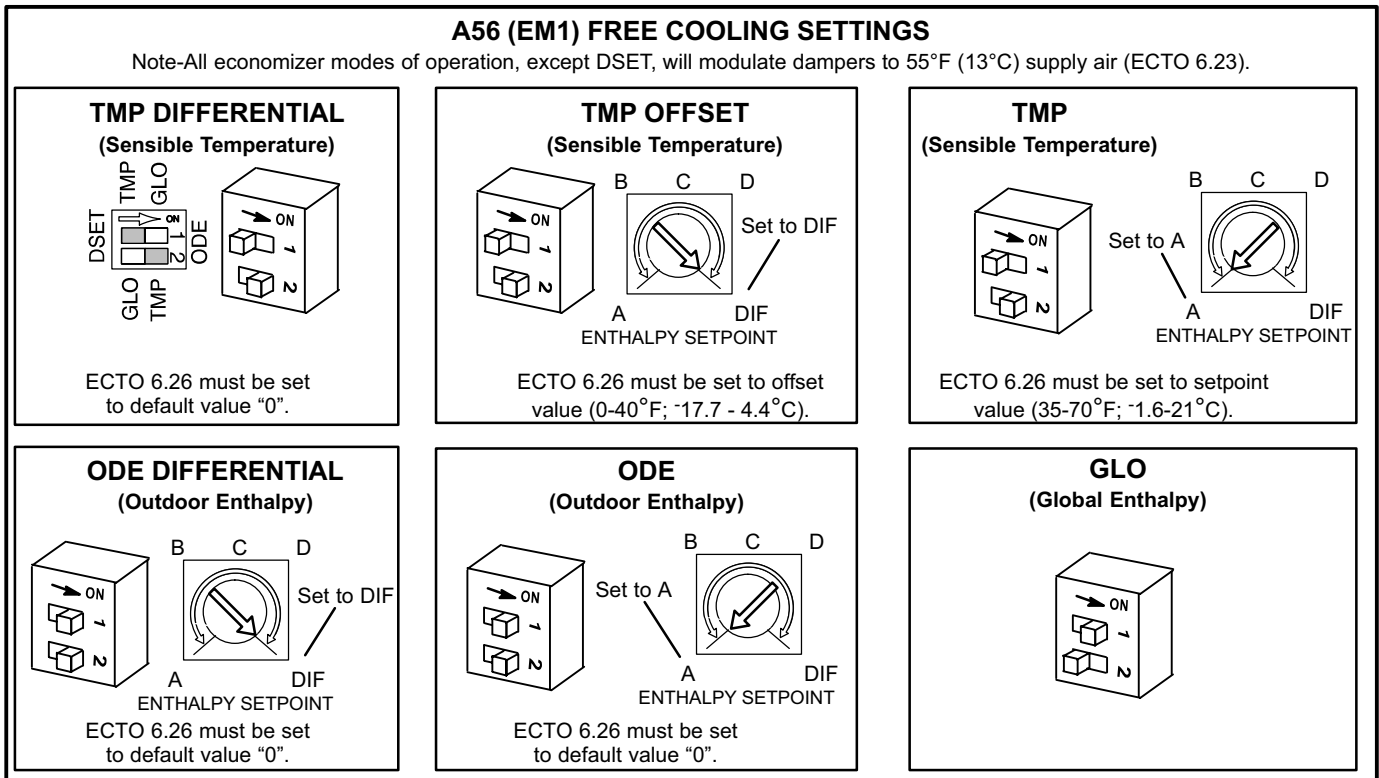
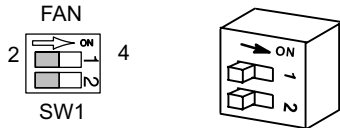

FIGURE 8

A61 (HP1) DIP SWITCH SETTINGS

(B AND C BOX HEAT PUMP UNITS ONLY;
NO HEAT PUMPS IN D BOX SIZE)

090 & 120 units which contain two fans.



180 & 240 units which contain four fans.

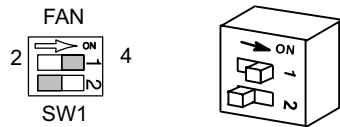

Switch #2 is not used.

FIGURE 9

A133 (GP1) DIP SWITCH SETTINGS

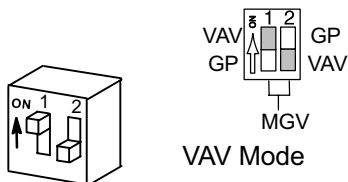

VAV Mode

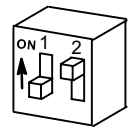

General Purpose Mode

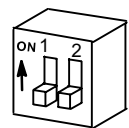

Modulating Gas Valve Mode

FIGURE 10

PUSHBUTTON

The pushbutton has various functions depending on DIP switch settings. The pushbutton is used to toggle through display readouts and turn outputs off and on.

By-Passing Delays

With DIP switches in normal operation setting, a short push of the pushbutton will bypass timers (such as compressor minimum run, blower delay, and compressor minimum-off). Delays are bypassed to energize unit functions immediately (or de-energize) for start-up and troubleshooting purposes.

NOTE - Each unit contains various delays and control components. Not all units will have the same components. See unit wiring schematic for applicable timers and delays.

Example:

If the unit contains a blower delay, the delay will keep the blower from immediately starting. A short push of the pushbutton will bypass this delay and the blower will operate.

In the same manner, if the unit has a compressor minimum run delay, a short push of the pushbutton will bypass the delay and the compressor(s) will de-energize.

CHECK SOFTWARE VERSION AND ADDRESS

Use the MODE DIP to check the A55 (M1-7) software version, the assigned address, and the advanced configuration data shown in table 3. See figure 11.

A single push of the pushbutton will advance to the next display. A double push on the pushbutton will return the readout to the previous display.

READ CONFIGURATION DATA

Set the MODE DIP "UNIT TEST" and "RECALL" switches to "ON"

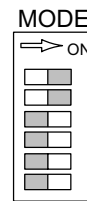

UNIT TEST
RECALL
ECTO
TEMP
OPT2
SHIFT

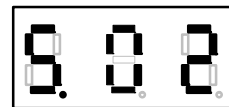
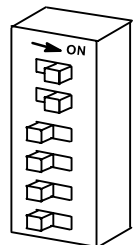

A single push advances the readout to the next display.

A double push moves the readout to the previous display.



FIGURE 11

**TABLE 3
CONFIGURATION DATA**

	Description	Readout
1	M1-7 IMC software version	x.xx
2	Unit address	1-31
3	Unit type-gas/electric	3x
	Unit type-electric/electric	4x
	Unit type-heat pump	5x
4*	Expansion board-A67 RH1	30
	Expansion board-A58 G1	50
	Expansion board-A60 E1	70
	Expansion board-A59 C2	80
	Expansion board-A133 GP1 (DIP sw. set to VAV)	A0
	Expansion board-A57 C1	b0
	Expansion board-A61 HP1	c0
	Expansion board-A133 GP1 (DIP sw. set to GP)	d0
	Expansion board-A56 EM1	E0
	Expansion board-A133 GP1 (DIP sw. set to MGV)	F0
5	Software build code (scrolling display)	xxxx--yyyy
6	Display alternates heating and cooling setpoints. Displayed setpoints are only used in zone sensor modes (6.01=1, 2, or 3).	HT/CL
7	Occupancy-occupied	ocP / 0
	Occupancy-unoccupied	ocP / 1
	Occupancy-override	ocP / 2
8	Application mode commands. Alternates between the two most recently received.	xxx/yyy

*Add-on board must be installed or readout won't display.

OPTIONAL GENERAL PURPOSE GP1 (A133)

The GP1-1 add-on boards have three optional modes: VAV Control (VAV), Modulating Gas Valve Control (MGV), and General Purpose (GP).

The mode is determined by the DIP switch setting and the position of the GP1 on the IMC. Each mode uses a different terminal block for field wired inputs and outputs. See figure 12.

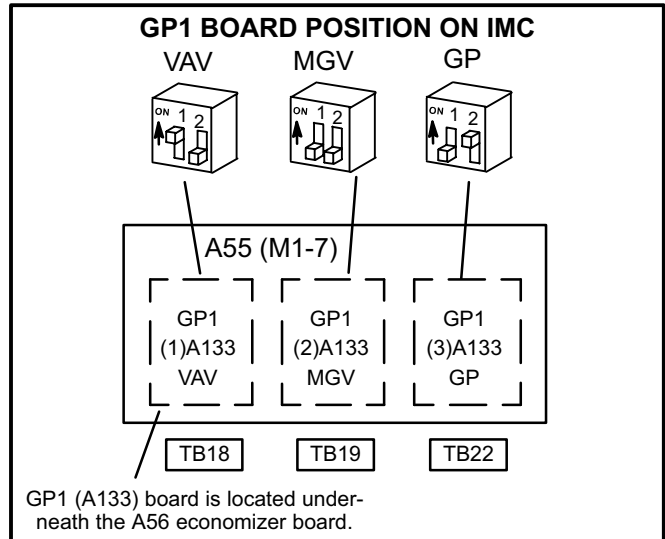

FIGURE 12

Up to three GP1 boards can be added to the M1-7, but the function of each board must be different. For example, two GP1 boards cannot be set to VAV mode.

This manual refers to the boards by function: VAV, MG, and GP. Wiring diagrams refer to the boards numerically: (1) A133 for VAV, (2) A133 for MG, and (3) A133 for GP as shown in figure 12. TB18, 19, and 22 are also specific to A133 function as shown in figure 12.

VAV Mode

The GP1 operates in the Variable Air Volume mode when the DIP switch is set to VAV. In this mode, the field wiring terminal block TB18 is connected to the GP1. This mode is used to control supply blower VFD on VAV units or bypass dampers on CAV units. This mode is also used on all exhaust fan modes except single stage fans controlled by fresh air damper position. See the VAV mode input/outputs in the back of this manual.

The IMC will set alarm code 100 if a GP1 board set to VAV mode is plugged in but at least one of the ECTO 0.01 or 0.23 or 8.16 option is not selected. ECTO 0.01 sets air delivery option, VAV, CAVB or staged. ECTO 0.23 sets the optional digital output operation. ECTO 8.16 selects the exhaust fan control option. Alarm 100 will also be set if ECTO 0.23 set to option 1-15 and ECTO 8.16 is set to option 8-15.

The GP1 board set to VAV mode can also be used as a general purpose board if the ECTO 0.01 is set to 0. In this mode the digital output may be programmed to operate according to the ECTO 0.23 and the analog inputs may be used to monitor analog signals. At least one of the

following ECTO values must be set or the IMC will display alarm 100: ECTO 0.01, 0.23, or 8.16.

GP Mode

The GP1 operates in the General Purpose mode when the DIP switch is set to GP. In this mode, the field wiring terminal block TB-22 is connected to the GP1. This mode is only used for optional control functions. The IMC will set alarm 102 unless ECTO 9.01 option 1-11, ECTO 9.12 option 1-11 or ECTO 9.23 option 1-15 is selected.

Option 9.01 selects the PID or staged control operation for analog output 1 and 9.12 selects the PID or staged control operation for analog output 2. ECTO 9.23 selects the operation of the digital output.

MGV Mode (Gas/Electric Units Only)

The GP1 operates in the Modulating Gas Valve mode when the DIP switch is set to MGV. In this mode, the field wiring terminal block TB-19 is connected to the GP1. This mode is used to control modulating gas valves. The IMC will set alarm 101 unless ECTO 3.13 option 1-6 or ECTO 3.21 option 1-15 is selected.

The GP1 board set to MGV mode can also be used as a general purpose board if the ECTO 3.13 is set to 1. In this mode the digital output may be programmed to operate according to the ECTO 3.21 and the analog inputs may be used to monitor analog signals.

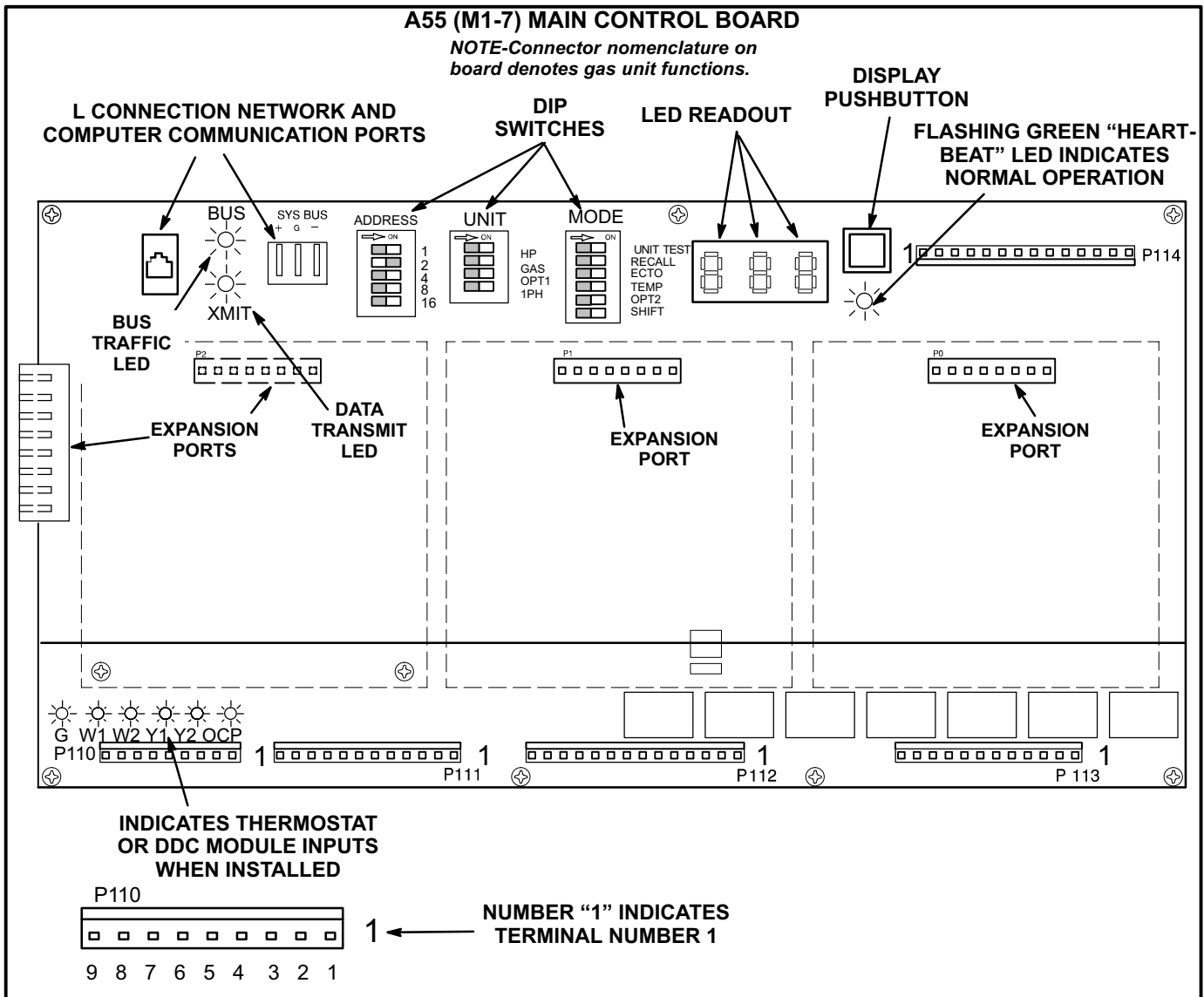

Unit Start-Up

VERIFY IMC FUNCTIONS (Local thermostat mode only)

On initial unit start-up identify the following IMC functions:

IMPORTANT - Before applying power, make sure MODE DIP switches, and UNIT "SHIFT" switch are off. At least one UNIT ADDRESS switch should be on.

- 1- Heartbeat LED on each board will flash.
- 2- LED readout will flash "8.8.8" and turn off.
- 3- Thermostat input indicating LED's will appropriately turn on.

Consider the IMC an input and output junction point; thermostat inputs at P110 result in an output to unit components (see 24VAC BO signal types in Input and Output tables). If the heartbeat LED is not flashing, see table 2 for heartbeat operation. If the LED readout contains a code, refer to the "Diagnostics" section to troubleshoot. If the thermostat input indicating lights are not responding appropriately, check the thermostat or DDC.

Figure 13 shows terminal block designations. Not all terminals blocks are found on all units.

UNIT OPERATION

Basic cooling and heating functions may be energized to test major unit components by using the IMC testing function or by using jumper wires on TB1.

UNIT START-UP WITH IMC TEST FUNCTION

Use "Testing Unit Function" section to simulate thermostat inputs. If outdoor fans, blowers, reversing valves, or the service relay do not respond appropriately, delays or low ambient temperatures may be preventing

operation. In that case, use "Testing Unit Function" section to create an output from the IMC to test specific components.

UNIT START-UP WITH TB1 JUMPERS

Note - Use TB1 jumpers only when a thermostat is installed and the IMC is set to system mode 0 (ECTO 6.01=0).

- 1- Disconnect power or turn thermostat (or electronic temperature control device) off.
- 2- Jumper TB1 terminals 6 (24V) to 3 (G) to maintain blower operation throughout checkout.
- 3- Jumper terminals as follows to confirm heating, cooling, and blower operation.

Note - When a jumper is removed, a delay may keep a component functioning. A short press on the M1 pushbutton will reset the delay.

TB1-6 to TB1-3	G	Blower
TB1-6 to TB1-18	Y1	First-Stage Cooling
TB1-6 to TB1-12	Y2	Second-Stage Cooling
TB1-6 to TB1-2	W1	First-Stage Heating
TB1-6 to TB1-13	W2	Second-Stage Heating
TB1-6 to *TB8-22	W3	Third-Stage Heating
TB1-6 to *TB8-23	W4	Fourth-Stage Heating
TB1-6 to *TB8-24	Y3	Third-Stage Cooling
TB1-6 to *TB8-25	Y4	Fourth-Stage Cooling

*Only available as an option on larger units containing A138 FS1 board.

Delays or low ambient temperatures may prevent outdoor fan, blower, reversing valve, or the service relay operation. Use "Testing Unit Function" section to create an output from the IMC to test specific outputs.

L SERIES AND S-CLASS FIELD WIRING TERMINAL BLOCK DESIGNATIONS

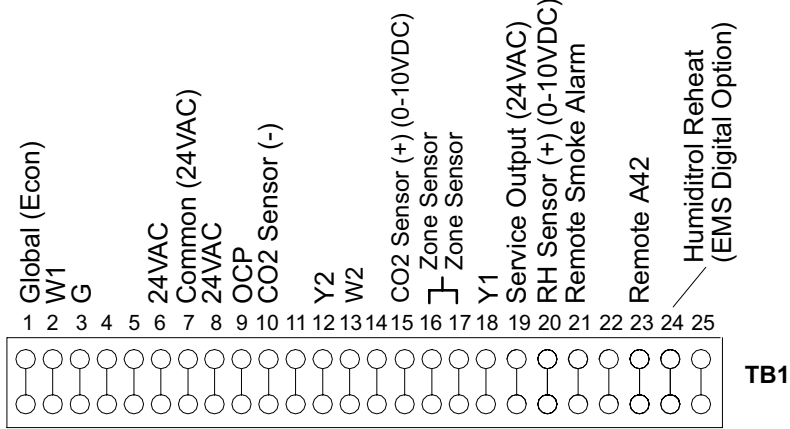

Note - TB1 designations do not apply to units using DDC modules. Refer to manufacturer's literature when a DDC module is used.

W3
W4
Y3
Y4
26 27 28 29

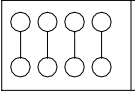

TB8

Used on large units equipped with optional A138 FS1 board.

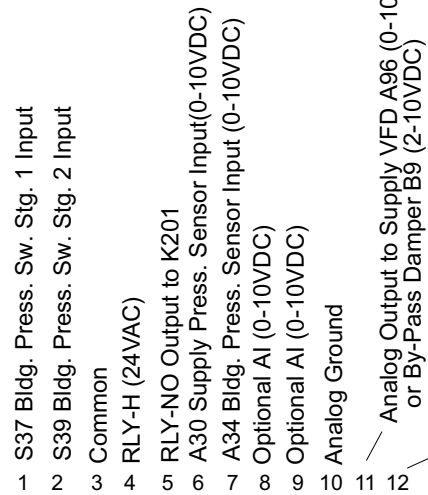

TB18

Used on VAV units, units with optional exhaust VFD, and/or units set up for supply by-pass dampers. A133 GP1 board (DIP set to VAV).



TB22

Used on units with optional A133 GP1 board; used as general purpose I/O. (DIP set to GP).

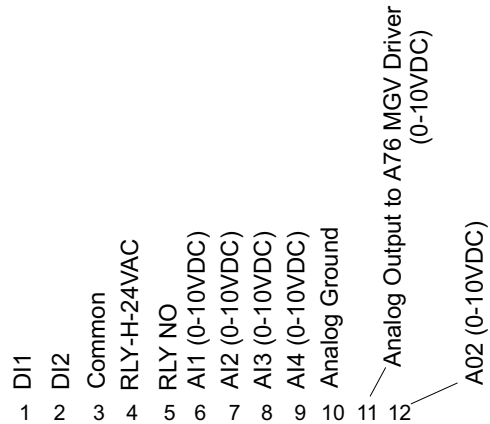

TB19

Used on units with optional modulating gas valve and A133 GP board. (DIP set to MGCV).

FIGURE 13

IMC CONTROL ERROR CODES

When an error occurs, the A55 M1-7 will display an error code which corresponds to control function. See table 4 and figure 14. Error codes are stored and can be recalled later.

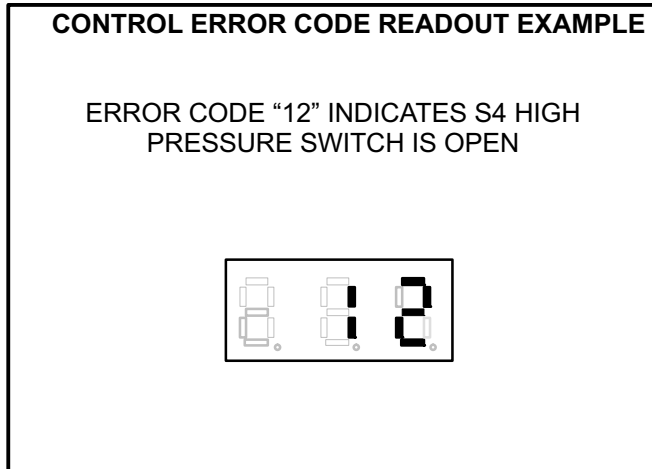

FIGURE 14

To read stored error codes set MODE DIP "RECALL" to "ON". See figure 15.

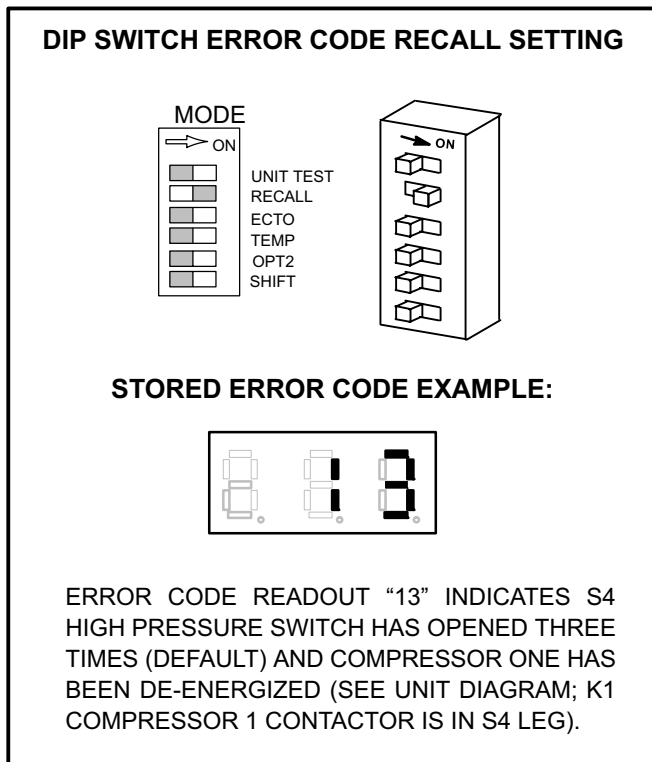

FIGURE 15

The most recent error code will be displayed first. If no codes are stored, a zero will be displayed. Stored codes are displayed in reverse order with each short push of the pushbutton. When the LED code no longer turns "off" and back "on", the last code has been reached. To read the error codes again, turn the MODE DIP "RECALL" off and back on. The most recent error code will again be displayed (with later codes stored in reverse).

Example:

- 1-Set MODE DIP "RECALL" to "ON". See figure 15.
- 2-Read display and refer to Control Error Code tables.

ERASE STORED ERROR CODES

To erase stored error codes the MODE DIP "RECALL" switch must be on. Hold down the pushbutton until a zero is displayed. A zero indicates that no error codes are stored. Turn off RECALL switch.

RESET LOCKOUT CONDITIONS

The IMC Error Code table 4 will indicate an error condition (such as a high pressure switch tripping). If an error results in a lock-out condition, two successive short pushes of the pushbutton will reset counters, lockout conditions, and timers.

Example:

Error code 13 indicates that the first-stage high pressure switch has opened three times (default) and the control has de-energized the compressor. A double push on the pushbutton will restart the compressor.

SERVICE OUTPUT

The IMC provides a 24 VAC output to monitor specific lockout error conditions (default). An asterisk in the error code table (Table 4) indicates an error condition which energizes the service output.

To activate the service light, connect the thermostat (or other alarm or monitoring device) service light terminal to unit TB1 terminal 19. See plug P113-3 in inputs and outputs table. Also see relay output (9) in "Testing Unit Function" section.

Turn on MODE DIP "RECALL" or reset control to de-activate the service relay output.

The service output may also be used for other purposes. See Service Output Operation section.

**TABLE 4
IMC ERROR CODES**

Error #	PROBLEM	ACTION
1	Power loss for two cycles. This may indicate that the unit power is "dirty" or is of low quality.	None on 3-phase units. 1-phase units: IMC will cycle compressor off for 5 minutes (default).
2	ECTO access error. This may indicate a problem with the ECTO memory chip and parameters may not be changeable.	Control will operate with the factory ECTO defaults.
3	Reserved.	
4*	A17 input indicates smoke alarm.	Defined by ECTO 5.01. Default action unit off.
5*	S52 (Air Flow Switch) This indicates no blower air 16 seconds after blower demand.	Unit off.
6*	S27 (Dirty Filter Switch) This indicates a dirty filter.	None
7-9	Reserved.	
10*	24 VAC power loss at TB35-1 on A55 (M1) board. P111 pin 11.	Unit off.
11*	24 VAC power loss at TB34-1 on A55 (M1) board. P113 pin 1.	Unit off.
12	S4 (High Press. 1) is open. Note: On Heat Pump 088S units, S4 or S5 (compr. discharge temp.) is open.	Compr. 1 off.
13*	S4 (High Press. 1) opened 3 (default) times during a demand. The number of times is defined in ECTO 1.12 or 4.14. Note: On Heat Pump 088S units, S4 or S5 (compr. discharge temp.) has opened 3 (default) times.	Compr. 1 locked off. To restore: 1- reset, 2- two short pushes of pushbutton, or 3-demand cycles to off.
14	S7 (High Press. 2) is open.	Compr. 2 off
15*	S7 (High Press. 2) opened 3 (default) time during a demand. The number of times is defined in ECTO 1.12 or 4.14.	Compr. 2 locked off. Requires a reset or two short pushes of pushbutton to restore.
16	S28 (High Press. 3) is open.	Compr. 3 off
17*	S28 (High Press. 3) opened 3 (default) time during a demand. The number of times is defined in ECTO 1.12 or 4.14	Compr. 3 locked off. Requires a reset or two short pushes of pushbutton to restore.
18	S96 (High Press. 4) is open.	Compr. 4 off
19*	S96 (High Press. 4) opened 3 (default) time during a demand. The number of times is defined in ECTO 1.12 or 4.14.	Compr. 4 locked off. Requires a reset or two short pushes of pushbutton to restore.
20	A42 input is open on A55 (M1) board P110 pin 9. Units with external overloads on the blower motor use this error to indicate tripped overload.	Unit off.
21*	A42 input has opened 3 (default) times. ECTO 5.08.	Unit locked off.
22	S87 (Low Press. 1) is open.	Compr.1 off.
23*	S87 (Low Press. 1) has opened 3 (default) times during a demand. The number of times is defined in ECTO 1.13 or 4.15.	Compr 1 locked off. Requires a reset or two short pushes of pushbutton to restore.
24	S88 (Low Press. 2) is open.	Compr. 2 off.
25*	S88 (Low Press. 2) has opened 3 (default) times during a demand. The number of times is defined in ECTO 1.13 or 4.15.	Compr 2 locked off. Requires a reset or two short pushes of pushbutton to restore.
26	S98 (Low Press. 3) is open.	Compr. 3 off.
27*	S98 (Low Press. 3) has opened 3 (default) times during a demand. The number of times is defined in ECTO 1.13 or 4.15.	Compr 3 locked off. Requires a reset or two short pushes of pushbutton to restore.
28	S97 (Low Press. 4) is open.	Compr.4 off
29*	S97 (Low Press. 4) has opened 3 (default) times during a demand. The number of times is defined in ECTO 1.13 or 4.15.	Compr 4 locked off. Requires a reset or two short pushes of pushbutton to restore.
30-31	Reserved.	
32	S49 (Freezestat 1) is open.	Compr. 1 off.
33*	S49 (Freezestat 1) has opened 3 (default) times during a demand. The number of times is defined in ECTO 4.04.	Compr. 1 locked off. Requires a reset or two short pushes of pushbutton to restore.
34	S50 (Freezestat 2) is open.	Compr. 2 off.
35*	S50 (Freeze stat 2) has opened 3 (default) times during a demand. The number of times is defined in ECTO 4.04.	Compr. 2 locked off. Requires a reset or two short pushes of pushbutton to restore.
36	S53 (Freeze stat 3) is open.	Compr. 3 off.

*Service output energized (default). + Not stored in memory.

IMC ERROR CODES

Error #	PROBLEM	ACTION
37*	S53 (Freeze stat 3) has opened 3 (default) times during a demand. The number of times is defined in ECTO 4.04	Compr. 3 locked off. Requires a reset or two short pushes of pushbutton to restore.
38	S95 (Freeze stat 4) is open.	Compr. 4 off.
39*	S95 (Freeze stat 4) has opened 3 (default) times during a demand. The number of times is defined in ECTO 4.04.	Compr. 4 locked off. Requires a reset or two short pushes of pushbutton to restore.
40+	Return air temperature (RT16) exceeded heating limit set in ECTO 5.06. See operation section.	Heating demand ignored. No heating.
41+	Return air temperature (RT16) exceeded cooling limit set in ECTO 5.07. See operation section.	Cooling demand ignored. No cooling.
42-43	Reserved.	
44*	Gas valve 1 is energized but no demand. (GV1). Check gas control and wiring.	Unit off
45*	Gas valve 2 is energized but no demand. (GV3). Check gas control and wiring.	Unit off.
46*	No 24VAC relay power on A60 (E1) board, K9-5 input. (A60)	Second heat section off.
47*	No 24VAC relay power on A58 (G1) board, TB35-1 input. (A58)	Second heat section off.
48*	No 24VAC relay power on A61(HP1) board, TB34-1 input. (A61)	Second compr. Off.
49*	No 24VAC relay power on A59 (C2) board, TB35-1 input. (A59)	Third and fourth compr. Off.
50	Gas Unit: S10, S130, or S131 (Primary Heat Limit) is open. Other Units: Jumper is open A55 P111 pin 1 and 2.	First heat section off.
51*	Gas Unit: S10, S130, S131 (Primary Heat Limit) has opened 3 (default) times during a demand ECTO 3.04. Other Units: Jumper is open. A55 P111 pin 1 & 2.	First heat section off.
52	Gas Unit: S21 (Secondary Heat Limit 1) is open. Other Units: Jumper is open. A55 P111 pin 1 and 2.	First heat section off.
53*	Gas Unit: S21 (Secondary Heat Limit 1) has opened 3 (default) times during a demand ECTO 3.04. Other Units: Jumper is open. A55 P111 pin 1 and 2.	First heat section off.
54	Gas Unit: S47 (Roll Out) is open. Other Units: S15 (El. Heat Limit) is open.	First heat section off.
55*	Gas Unit: S47 (Roll Out Switch 1) opened 1 (default) time during a demand. ECTO 3.08. Other Units: S15 (El. Heat Limit 1) has opened 3 or 5 (default) times during a demand. ECTO 1.04 or 2.04.	First heat section off.
56	Gas Unit: S18 (Combustion Air Proof Switch 1) is open. Other Units: S63 (El. Heat Limit) is open.	First heat section off.
57*	Gas Unit: S18 (Combustion Air Proof Switch 1) has opened 3 (default) times during a demand. ECTO 3.07. Other Units: S63 (El. Heat Limit) has opened 3 (default) times during a demand. ECTO 2.04	First heat section off.
58	Gas valve 1 not energized two minutes after thermostat demand. Check gas supply, ignition control, and wiring. (GV1)	Only action taken is storing code in memory.
59*	Gas valve 1 not energized 3 (default) times (2 minutes after a demand). Check gas supply, ignition control and wiring. ECTO 3.09. (GV1)	Only action taken is storing code in memory.
60	S99 (Primary Heat Limit 2) is open.	Second heat section off.
61*	S99 (Prim. Ht. Lim. 2) has opened 3 (default) times during a demand. ECTO 3.04	Second heat section off.
62	S100 (Secondary Heat Limit 2) is open.	Second heat section off.
63*	S100 (Secondary Heat Limit 2) has opened 3 (default) times during a demand. ECTO 3.04.	Second heat section off.
64	S69 (Roll Out Switch 2) is open.	Second heat section off.
65*	S69 (Roll Out Switch 2) has opened 1 (default) times during a demand. ECTO 3.08.	Second heat section off.
66	S45 (Combustion Air Proof Switch 2) is open.	Second heat section off.
67*	S45 (Combustion Air Proof Switch 2) has opened 3 (default) times during a demand. ECTO 3.07.	Second heat section off.
68	Gas valve 2 not energized two minutes after demand. Check gas supply, ignition control, and wiring (GV3).	Only action taken is storing code in memory.
69*	Gas valve 2 not energized 3 (default) times (2 minutes after demand). Check gas supply, ignition control and wiring. ECTO 3.09. (GV3).	Only action taken is storing code in memory.

*Service output energized (default). + Not stored in memory.

IMC ERROR CODES

Error #	PROBLEM	ACTION
70-72	Reserved.	
73	Network fails to send all remote sensor data within 5-minute window. Cleared by IMC reset or when missing network data is received.	Local sensor data is used for sensors which failed to update.
74*	Zone sensor (A2) problem. Check sensor and wiring.	IMC will switch over to the backup mode option set with ECTO 6.01. If no backup mode is selected, the unit will shut down.
75*	Outdoor Temperature (RT17) Sensor Problem. Check wiring and sensor.	The control defaults to a high outdoor temp. operation.
76*	Relative humidity sensor (A91) problem. Check sensor and wiring.	No reheat.
77*	Discharge (Supply) Air Temperature Sensor (RT6) problem. Check wiring and sensor.	No free cooling. Economizer damper will close. All economizer modes. No FAC, FAH, DACC, or DACH.
78*	Return Air Temperature Sensor (RT16) problem. Check wiring and sensor.	No free cooling if economizer is in TMP (temperature) mode, dampers will closed.
79*	A major communication problem between the main board and add-on boards has occurred. Alarm can also be caused by multiple GP1 (A133) boards set to the same mode.	Main control has locked out all add-on boards. Reset control to restore.
80	A communication problem between the main board and add-on board has occurred. Alarm can also be caused by multiple GP1 (A133) boards set to the same mode.	Main board has reset the communications to the add-on boards.
81	IMC configuration error. Unit DIP sw. is set to cooling or heat pump unit but ECTO 4.24 options 1 & 2 apply to gas units OR Unit DIP sw. is set to heat pump but ECTO 4.24 options 3, 5, 6, and 7 apply to Humiditrol® units.	No reheat.
82	Main board reset or power outage has occurred.	Only action taken is store code in memory. Note - This code is always recorded at power up and is only displayed in error recall mode.
83*	IMC configuration error. The add-on boards plugged into the main control don't agree with the UNIT DIP switch settings. I.E. Switch is set for gas, but main board detects an electric heat board. Check UNIT DIP switch setting and add-on boards types.	Unit is off.
84*	An add-on board did not respond or is not recognized when polled by main control during system power-up. Add-on board with problem will have flickering heartbeat or no heartbeat.	Main control has locked out all add-on boards. Reset control to restore.
85	Humiditrol reheat ECTO 4.24 is set to option 3, 5, 6, or 7, or ECTO 4.25 is set to 100, but RH1 add-on board is not installed OR the RH1 add-on board is detected but ECTO 4.24 is not set to option 3, 5, 6, or 7, or ECTO 4.25 set to 100.	No reheat.
86*	Thermostat input conflict. Simultaneous heat and cool demands. Check thermostat wiring.	Unit is off.
87*	UNIT (equipment type) DIP switch has changed while unit is energized. Check UNIT DIP switch setting and reset control. Make sure the UNIT DIP switch settings agree with the unit type.	Unit is off.
88	This may indicate a problem with the ECTO chip.	Control will operate on factory default ECTO settings.
89	No address is set on unit address DIP switch SW3. Any one switch on SW3 must be in "on" position. SW3 is factory set with switch #2 in on position.	Local operation only.
90	RAM error.	System reset.
91*	Outdoor enthalpy sensor (A7) open. Check sensor and wiring.	No economizer free cooling operation if economizer mode is set to ODE or DIF.
92*	Indoor enthalpy sensor (A62) open. Check sensor and wiring.	No economizer free cooling operation if economizer mode is set to DIF.
93*	The control has changed the system mode because of an error with the controlling sensor or because of a loss of communication.	IMC has switched over to the backup mode option set with ECTO 6.01.
94	Zone sensor setpoint out-of-range error.	IMC reverts to default 65°F (18°C) heating and 80°F (27°C) cooling setpoints.

*Service output energized (default). + Not stored in memory.

IMC ERROR CODES

Error #	PROBLEM	ACTION
95	ECTO parameter has been changed by the pushbutton.	For information only. Indicates that someone has made an ECTO change.
96*	Four stage interface failure A138. ECTO 6.01 set to option 12 when no A138 board present can also cause this alarm	No heating or cooling.
97*	Four stage interface A138 detected but ECTO 6.01 is not set to option 12 or equipment type is set to heat pump.	No heating or cooling.
98	ECTO memory chip write error.	ECTO settings may not be saved.
99*	Outdoor Air Control Sensor (A24) open. Cleared by IMC reset.	No OAC operation. Damper closed to minimum position.
100	VAV, CAV, w/bypass damper, or exhaust fan configuration error. Cases that can cause this alarm: 1-GP1 (A133 w/ DIP set to VAV) present but no ECTO 0.01, 0.23, or 8.16 option selected. 2-ECTO 0.01, 0.23, or 8.16 option is selected, but no GP1 present (A133 w/DIP set to VAV). 3-ECTO 8.16 option 1-23 is selected but no A56 board present. 4-ECTO 0.23 set to option 1-15 and ECTO 8.16 is set to option 8-15. 5-ECTO 5.01 set to option 5-7 and ECTO 8.16 is set to option 8-15. 6-ECTO 5.01 set to option 5-7, but no GP1 present (A133 w/DIP set to VAV). 7-ECTO 5.01 set to option 5-7, but no EM1 (A56) present. 8-ECTO 7.25 option 12-15 selected, but no GP1 present (A133 w/DIP set to VAV).	Affected features do not operate.
101	MGV configuration error. Cases that can cause this alarm: 1-ECTO 3.13 option 1-6 or ECTO 3.21 option 1-15 selected, but no GP1 (A133) (W/DIP set to MGV) is present. 2-GP1 (A133) (W/DIP set to MGV) is present, but no ECTO 3.13 option 1-6 nor ECTO 3.21 option 1-15 has been selected. 3-ECTO 7.25 option 8-11 selected, but no GP1 (A133) (W/DIP set to MGV) is present.	Affected features (e.g. modulating heat) do not operate.
102	GP configuration error. Cases that can cause this alarm: 1-ECTO 9.01 option 1-11, ECTO 9.12 option 1-11 or ECTO 9.23 option 1-15 selected, but no GP1(A133) (w/DIP set to GP) present. 2-GP1(A133) (w/DIP set to GP) present, but no ECTO 9.01 option 1-11 nor ECTO 9.12 option 1-11, nor ECTO 9.23 option 1-15 has been selected. 3-ECTO 7.25 option 4-7 selected, but no GP1 (A133) (W/DIP set to GP) is present.	Affected features do not operate.
103	General configuration error. ECTO option is set to use an input that is not present. Cases that can cause this alarm: 1-ECTO 7.25 option 1 is selected 2-ECTO 7.25 option 2 or 3 selected, but no A56 board present. 3-ECTO 7.04 option is set to less than 71F (Reheat_FAT enabled) but no A56 board present. 4-ECTO 5.04 option 4 (DACC) or ECTO 5.09 option 1 (DACH) selected on heat pumps. DACC and DACH not allowed on heat pumps. 5-ECTO 4.24 option is set to 1-3 or 5-7 (reheat modes) and ECTO 5.04 option 4 (DACC) is selected. DACC is not allowed with reheat. 6-ECTO 7.04 option is set to less than 71F (Reheat_FAT enabled) and ECTO 4.24 is set to option 0 or 1. Reheat_FAT not allowed with ECTO options 0 or 1. 7-ECTO 7.22 Input source (X) is greater than 9.	Affected features do not operate.
104	Reserved.	
105	Economizer configuration error. ECTO 6.26 does not agree with A56 DIP settings, or ECTO 6.26 is out of range for mode selected. Cases that can cause this alarm: 1-A56 DIP is set to ODE and ECTO 6.26 is set to a non-zero value. 2-A56 DIP is set to TMP, A56 pot is set to ABCD, and ECTO 6.26 is set to a temperature setting greater than 70°F or less than 35°F. 3-A56 DIP is set to TMP, A56 pot is set to DIFF and ECTO 6.26 is set to a temperature setting greater than 40°F or less than 0°F.	1-Normal ODE operation. 2-No free cooling. 3-No free cooling.

*Service output energized (default). + Not stored in memory.

IMC ERROR CODES

Error #	PROBLEM	ACTION
106*	Building air pressure sensor A34 problem. Occurs only when: 1-GP1 is present. 2-A133 DIP switch is set to VAV. 3-ECTO 8.16 is set to 4-7 or 12-23. 4-A34 input (A133_P194-7) is less than 0.2VDC (-.48"w.c.) or higher than 9.8VDC (0.48"w.c.). The error code is cleared when the A34 sensor input is between 0.2 and 9.8 VDC.	No exhaust fan operation.
107*	Supply duct pressure sensor A30 problem. Occurs only when: 1-GP1 is present. 2-A133 DIP switch is set to VAV. 3-ECTO 0.01 is not 0. 4-PID mode is selected in ECTO 0.01 AND A30 sensor input (A133_P194-6) is greater than 9.8VDC (4.9"w.c.) OR the blower has been operating for at least 16 seconds, the VFD or bypass damper output is greater than ECTO 0.26, AND A30 sensor input is less than 0.2VDC (0.10"w.c.).	Unit off.
108	Supply duct pressure exceeded maximum limit set by ECTO 0.21 for more than 20 seconds.	Unit off.
109*	Error 107 and/or 108 has occurred 3 (default) times (ECTO 0.22). Error 107 has occurred once (ECTO 0.22 set to 0). Error 108 lockout disabled (ECTO 0.22 set to 0). Error 107 accumulation is cleared after 8 hrs. of no error 107 and on IMC reset. Error 108 accumulation is cleared on IMC reset only.	Unit lock-out. Requires reset.
110+	IMC waiting up to 5 minutes for network sensor data defined in ECTO 5.27. Clears when all network data is received.	Unit off.
111-126	Reserved.	
127	Error buffer overflow.	This means multiple errors occurred and some have not been stored.
128-255	Reserved.	

*Service output energized (default). + Not stored in memory.

Main Control Operation

SYSTEM MODE

The IMC will operate the unit from a thermostat, zone sensor, zoning system or the FS1-1 (A138) controller based on the System Mode selected in ECTO 6.01. The default System Mode (option 0) is the thermostat mode. DDC applications use thermostat mode for two or three-stage cooling and two-stage heating. FS1-1 mode is used for four-stage heating and four-stage cooling.

Thermostat Mode

Units are shipped from the factory in system mode 0, Thermostat Mode. The IMC will operate two stages of heating and cooling based on the thermostat Y1, Y2, W1, W2, G, and OCP (occupied) demands.

Cooling Stages

The IMC allows three different staging options; adjust ECTO 5.04 to select the option.

Option 1 Two-Stages:

A Y2 demand brings on all mechanical stages of cooling during economizer operation.

- CP1 = Compressor 1 CP3 = Compressor 3**
- CP2 = Compressor 2 CP4 = Compressor 4**

Option 2 (Default) Two Stages:

Cooling operation is shown in table 5. A Y2 demand brings 1/2 or 2/3 mechanical stages of cooling during economizer operation.

Option 3 Three Stages:

Cooling operation is shown in table 6. Three cooling stages (option 3) requires the use of a three-stage cool thermostat and a K27 relay. See wiring pictorial in figure 16 and wiring diagram control C section.

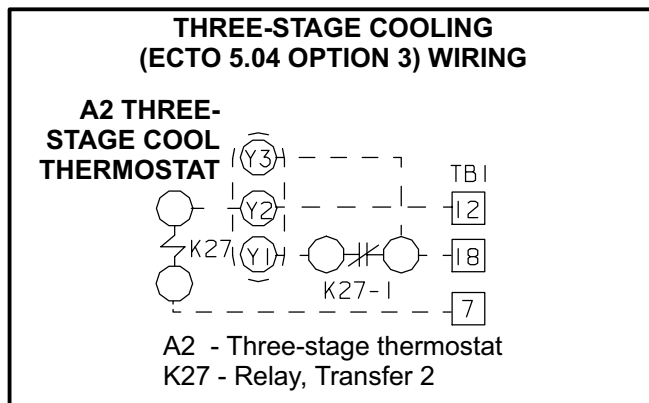

FIGURE 16

**TABLE 5
THERMOSTAT MODE OPERATION DEFAULT (TWO COOLING STAGES ECTO 5.04 OPTION 2)**

No Economizer

No. of Compressors	Y1 Demand	Y2 Demand Adds
1	CP1	CP1
2	CP1	CP2
3	CP1 + CP2	CP3
4	CP1 + CP2	CP3 + CP4

With Economizer*

No. of Compressors	Y1 Demand	Y2 Demand Adds
1	Free Cool	CP1
2	Free Cool	CP1 ⁽¹⁾
3	Free Cool	CP1 + CP2 ⁽¹⁾
4	Free Cool	CP1 + CP2 ⁽¹⁾

⁽¹⁾ - ECTO 5.04 option 1 will bring on all available mechanical cooling.

*Assumes outdoor air is suitable for cooling.

**TABLE 6
THERMOSTAT MODE OPERATION (THREE COOLING STAGES ECTO 5.04 OPTION 3)**

No Economizer

Number of Compressors	Y1 Demand	Y2 Demand Adds	Y3 Demand Adds
1	CP1	CP1	CP1
2	CP1	CP2	CP2
3	CP1	CP2	CP3
4	CP1 + CP2	CP3	CP4

With Economizer*

Number of Compressors	Y1 Demand	Y2 Demand	Y3 Demand Adds
1	Free Cool	CP1	CP1
2	Free Cool	CP1	CP2
3	Free Cool	CP1	CP2
4	Free Cool	CP1 + CP2	CP3

*Assumes outdoor air is suitable for cooling.

Heating Stages

The IMC default thermostat operation is for two heating stages. See table 7 for gas heat units, table 8 for electric heat units, and table 9 for heat pump units.

**TABLE 7
DEFAULT T'STAT MODE OPERATION (GAS HT)**

No. of Heat Sections	Gas Valve	W1 Demand	W2 Demand
1	(1) 1 Stg.	Gas Valve 1	Gas Valve 1
1	(1) 2 Stg.	Low Rate	High Rate
2	(2) 1 Stg.	High Rate Both Valves	High Rate Both Valves
2	(2) 2 Stg.	Low Rate Both Valves	High Rate Both Valves

**TABLE 8
DEFAULT T'STAT MODE OPERATION
(ELECTRIC HEAT)**

No. of Heat Sections	Stages Per Section	W1 Demand	W2 Demand
1	1	Stage 1	Stage 1
1	2	Stage 1	Stage 2
2	1	High Rate Both Sections	High Rate Both Sections
2	2	Low Rate Both Sections	High Rate Both Sections

**TABLE 9
THERMOSTAT MODE OPERATION (HP HEAT)**

Unit Type	W1 Demand	W2 Demand Adds
1 Compressor 1 Stg. Elect. Ht.	CP1 Heating	Electric Heat
2 Compressors 1 Stg. Elect. Ht.	CP1 + CP2 Heating	Electric Heat

Zone Sensor Mode

ECTO 6.01 option 1, 2, or 3 allows the IMC to use internal setpoints and input from a zone sensor to operate the unit. An additional thermostat or Energy Management System is not required.

Internal setpoints can be adjusted using the pushbutton and DIP switches on the M1 board. Refer to the Electronic Configure To Order (ECTO) section in this manual. In zone sensor mode, during the occupied time period, the default IMC internal heating and cooling setpoints are:

Cooling setpoint: 74°F (ECTO 6.04)

Heating setpoint: 70°F (ECTO 6.02)

Use ECTO stage differential and deadband options to adjust setpoints in zone sensor mode.

Network Control Panel (NCP)

The setpoints can also be adjusted using the optional NCP Network Control Panel. When an NCP is installed, the setpoints are determined by the NCP schedule. The NCP communicates with the IMC via the L Connection network bus. Internal IMC setpoints are used only if network communication is interrupted.

The zone sensor is wired directly to each unit TB1-16 and 17. The zone sensor wiring diagram key number is A2.

Zone Sensor Back-Up Modes

Select the appropriate ECTO 6.01 option to determine the zone sensor back-up mode. The back-up mode is used in the event that the A2 room sensor fails or is disconnected.

Option 1-IMC Zone Sensor System Mode 1 has no back-up mode of control should the A2 zone sensor fail.

Option 2-IMC Zone Sensor System Mode 2 will default to a local thermostat if one is installed (should the A2 zone sensor fail). The IMC will switch over and operate based on the signals from the room thermostat.

Option 3-IMC Zone Sensor System Mode 3 will default to return air sensor RT16 (should the A2 zone sensor fail). The IMC will switch over and operate based on the temperature from the return air sensor. **RT16 is standard on all L Series units; therefore IMC Zone Sensor System Mode 3 is the recommended System Mode when units are setup in the zone sensor mode.**

NOTE - The RT16 has a lower resolution than the A2 zone sensor and should only be used as back-up.

L Connection Network Back-Up Setpoints

ECTO 6.02 through 6.05 back-up setpoints are used when the communication link has been lost on the L Connection system bus. Five minutes after communication is interrupted, the IMC will reset and start using the back-up setpoints. The IMC will default to occupied (6.02 & 6.04) back-up setpoints when the factory-installed jumper between unit TB1-8 & 9 is left in place. **It is recommended that occupied back-up setpoints be used.** If the unoccupied (6.03 & 6.05) back-up setpoints are desired, remove the factory-installed jumper between TB1 8 & 9.

During normal zone sensor operation with an NCP, the occupied demands are sent over the network and the occupied input on TB1 is ignored. The occupied input on TB1 is only read if the network communication link is lost.

Heating and Cooling Stages in Zone Sensor Mode

In Zone Sensor Mode, default operation, the IMC controls up to 4 stages of heating and 4 stages of cooling. See figure 17 and ECTO parameters in table 10.

The number of stages achieved is dependent on the type of equipment and whether or not an economizer is used. On units with economizers, free cooling becomes stage 1 and all compressor stages shift up one stage. On units with 4 compressors and an economizer, compressors 3 and 4 are controlled together for stage 4. See figure 17 and the ECTO parameters in table 10.

Off Delay in Zone Sensor Mode

In Zone Sensor Mode, the IMC initiates a 2-minute off delay on any power-up or reset. During the 2-minute delay, no blower, heating, or cooling operation will occur. This delay may be adjusted to stagger the start of each unit, reducing the initial power demand. (ECTO 5.25).

Blower Operation in Zone Sensor Mode

In Zone Sensor Mode, default operation, the IMC cycles the blower with a heat/cool demand. ECTO 6.17 can be changed to allow continuous blower operation.

**TABLE 10
ZONE SENSOR ECTO SUMMARY**

No.	Name	Min	De- fault	Max.	Units	Description
Heat Pump Heating						
1.18	Sup_HT_1_Diff	0 0	8 2	15 3.75	Counts W:DegF	Supplemental heat stage 1 differential. Used in zone sensor applications. Note: Differential temperature must be = to or < ECTO 1.19.
1.19	Sup_HT_2_Diff	0 0	12 3	15 3.75	Counts W:DegF	Supplemental heat stage 2 differential. Used in zone sensor applications. Note: Differential temperature must be = to or > ECTO 1.18
1.20	Sup_HT_1_Latch_Option	0	0	1	Option	Supplemental heat stage 1 latch option. Used in zone sensor applications. 0: Latch Disabled 1: Latch Enabled
1.21	Sup_HT_2_Latch_Option	0	0	1	Option	Supplemental heat stage 2 latch option. Used in zone sensor applications. 0: Latch Disabled 1: Latch Enabled
1.22	Sup_HT_1_StgUp_Timer	0 0	0 0	225 3600	Counts F:Sec	Supplemental heat stage 1 stage-up timer. The maximum time that stage 1 runs before calling supplemental heat stage 1. Used in zone sensor applications. Disabled if set to 0.
1.23	Sup_HT_2_StgUp_Timer	0 0	0 0	225 3600	Counts F:Sec.	Supplemental heat stage 2 stage-up timer. The maximum time that supplemental heat 1 runs before calling supplemental heat stage 2. Used in zone sensor applications. Disabled if set to 0.
1.24	StgDn_Timer	0 0	19 304	225 3600	Counts F:Sec	Time delay before a lower stage turns off following a higher stage termination. Used in zone sensor applications.
Electric Heat						
2.06	Stg_Latch_Option	0	0	1	Option	Stage latch option. Used in zone sensor applications. 0: Latch Disabled 1: Latch Enabled
2.07	StgUp_Timer	0 0	57 912	225 3600	Counts F:Sec	Stage up timer. The maximum time that lower stage runs before calling next heat stage. Used in zone sensor applications. Disabled if set to 0.
2.08	StgDn_Timer	0 0	0 0	225 3600	Counts F: Sec	Time delay before a lower stage turns off following a higher stage termination. Used in zone sensor applications.
Gas Heat						
3.10	Stg_Latch_Option	0	0	1	Option	Stage latch option. Used in zone sensor applications. 0: Latch Disabled 1: Latch Enabled
3.11	StgUp_Timer	0 0	57 912	225 3600	Counts F: Sec	Stage-up timer. The maximum time that lower stage runs before calling next heat stage. Used in zone sensor applications. Disabled if set to 0.
3.12	StgDn_Timer	0 0	0 0	225 3600	Counts F: Sec	Time delay before a lower stage turns off following a higher stage termination. Used in zone sensor applications.
Cooling						
4.17	Stg_2_Latch	0	0	1	Option	Stage 2 latch option. Used in zone sensor applications. 0: Latch Disabled 1: Latch Enabled
4.18	Stg_3_Latch	0	0	1	Option	Stage 3 latch option. Used in zone sensor applications. 0: Latch Disabled 1: Latch Enabled
4.19	Stg_4_Latch	0	0	1	Option	Stage 4 latch option. Used in zone sensor applications. 0: Latch Disabled 1: Latch Enabled
4.20	Stg_2_StgUp_Timer	0 0	57 912	225 3600	Counts F:Sec	Stage 2 stage up timer. The maximum time that cooling stage 1 runs before calling cooling stage 2. Used in zone sensor applications. Disabled if set to 0.
4.21	Stg_3_StgUp_Timer	0 0	57 912	225 3600	Counts F:Sec	Stage 3 stage up timer. The maximum time that cooling stage 2 runs before calling cooling stage 3. Used in zone sensor applications. Disabled if set to 0.
4.22	Stg_4_StgUp_Timer	0 0	57 912	225 3600	Counts F:Sec	Stage 4 stage up timer. The maximum time that cooling stage 3 runs before calling cooling stage 4. Used in zone sensor applications. Disabled if set to 0.
4.23	StgDn_Timer	0 0	57 912	225 3600	Counts F:Sec	Time delay before a lower stage turns off following a higher stage termination. Used in zone sensor applications.

General						
Control Parameter		Control Value			Units	Description
No.	Name	Min	De- fault	Max.		
5.25	Zone_Sensor_StartUp_Delay	15 2	15 2	225 30	Counts C:Min.	Start-up demand delay. Holds off all unit operation zone sensor and CAVB applications. Hold off FAH-Reheat, FAC, FAH options and all GP outputs. May be used to stagger unit start-ups. Does NOT delay demands in thermostat mode.
6.01	System_Mode	0	0	12	Option	System mode of operation. Control Value System Mode Backup Mode 0 Local Thermostat None 1 Zone Sensor None 2 Zone Sensor Local Thermostat 3 Zone Sensor Return Air Sensor 4 Remote Demand None 5 Remote Demand Local Thermostat 6 Remote Demand Return Air Sensor 7 Remote Demand Zone Sensor 8 Future Use None 9 Future Use Local Thermostat 10 Future Use Return Air Sensor 11 Future Use Zone Sensor 12 A138 4-Stg. Tstat Interface None
6.02	OCP_HT_BkUp_SP	20 95	120 70	240 40	Counts Z:DegF	Backup occupied heating setpoint. Used if the communications link is lost for 5 minutes between the IMC and NCP. Used only with zone sensor applications. Setpoint temperature must be < or = (6.04 - 6.15).
6.03	UnOcp_HT_BkUp_SP	20 95	160 60	240 40	Counts Z:Deg F	Backup unoccupied heating setpoint. Used if the communications link is lost for 5 minutes between the IMC and NCP. Used only in zone sensor applications. Setpoint temperature must be < or = (6.05 - 6.15).
6.04	Ocp_CL_BkUp_SP	20 95	100 75	240 40	Counts Z:DegF	Backup occupied cooling setpoint. Used if the communications link is lost for 5 minutes between the IMC and NCP. Used only in zone sensor applications. Setpoint temperature must be > or = (6.02 + 6.15).
6.05	UnOcp_CL_BkUp_SP	20 95	60 85	240 40	Counts Z:DegF	Backup unoccupied cooling setpoint. Used if the communications link is lost for 5 minutes between the IMC and NCP. Used only in zone sensor applications. Setpoint temperature must be > or = (6.03 + 6.15).
6.06	Override_Timer	0 0	28 3584	225 28800	Counts E: Sec	After hours override timer. Only used on zone sensor applications without a Network Control Panel (NPC).
6.07	HT_Stg_DB	4 1	4 1	15 3.75	Counts W:DegF	Heating deadband. Used only with IMC zone sensor applications. Deadband must be < or = 6.15 - 6.08.
6.08	CL_Stg_DB	4 1	4 1	15 3.75	Counts W:DegF	Cooling deadband. Used only with zone sensor applications. Deadband must be < or = 6.15 - 6.07.
6.09	Stg_1_HT_Diff	0 0	2 0.5	12 3	Counts W:DegF	Heating stage 1 differential. Used only with zone sensor applications. Differential temperature must be < or = 6.11.
6.10	Stg_1_CL_Diff	0 0	2 0.5	12 3	Counts W:DegF	Cooling stage 1 differential. Used only with zone sensor applications. Differential temperature must be < or = 6.12.
6.11	Stg_2_HT_Diff	0 0	4 1	12 3	Counts W:DegF	Heating stage 2 differential. Used only with zone sensor applications. Differential temperature must be > or = 6.09.
6.12	Stg_2_CL_Diff	0 0	4 1	12 3	Counts W:DegF	Cooling stage 2 differential. Used only with zone sensor applications. Differential temperature must be > or = 6.10 AND < or = 6.13.
6.13	Stg_3_CL_Diff	0 0	6 1.5	12 3	Counts W:DegF	Cooling stage 3 differential. Used only with zone sensor applications. Differential temperature must be > or = 6.12 AND < or = 6.14.
6.14	Stg_4_CL_Diff	0 0	8 2	12 3	Counts W:DegF	Cooling stage 4 differential. Used only with zone sensor applications. Differential temperature must be > or = 6.13.
6.15	Zone_Sensor Autochange-over DB_Min	8 2	12 3	40 10	Counts W:DegF	Minimum autochangeover deadband temperature. Deadband must be > or = (6.07 + 6.08). Used in zone sensor applications.

ZONE SENSOR STAGES FOR GAS / ELECTRIC UNITS Default Values Shown

Units With Economizer:

C1=Free Cooling

C2=Compressor 1

C3=Compressor 2

C4=Compressor 3 + 4

C1=Cooling Stage 1

C2=Cooling Stage 2

C3=Cooling Stage 3

C4=Cooling Stage 4

H1=Heating Stage 1

H2=Heating Stage 2

H3=Heating Stage 3

H4=Heating Stage 4

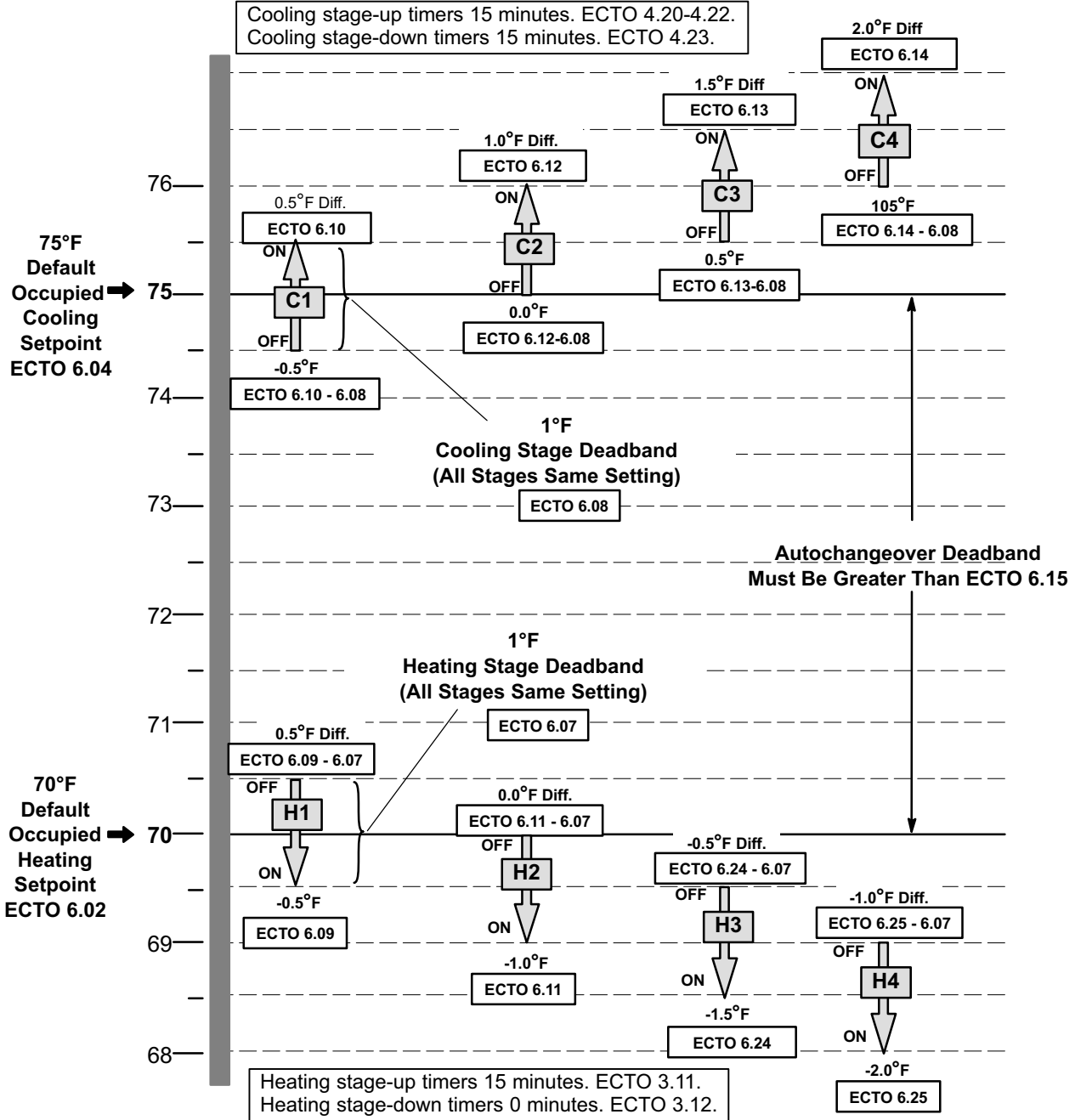

FIGURE 17

Four Stage Interface Mode

ECTO 6.01 option 12 provides two additional heating and cooling 24VAC demand inputs W3, W4, Y3 and Y4 for large gas/electric and electric/electric units. This option requires a DDC or thermostat with 4 heat/4 cool capability and a unit with a factory-installed FS1 board (A138).

The FS1 board can only be used on gas/electric and electric/electric units; not heat pump units.

See tables 11 through 14 for operation.

Use the input demand LED's on the FS1 board instead of the M1-7 board. See figure 18.

**TABLE 11
FS1 COOLING OPERATION - NO ECONOMIZER
(ECTO 6.01 OPTION 12)**

No. of Compressors	Y1 Demand	Y2 Demand Adds	Y3 Demand Adds	Y4 Demand Adds
3	CP1	CP2	CP3	CP3
4	CP1	CP2	CP3	CP4

**TABLE 12
FS1 COOLING OPERATION - WITH ECONOMIZER
(ECTO 6.01 OPTION 12)**

No. of Compressors	Y1 Demand	Y2 Demand Adds	Y3 Demand Adds	Y4 Demand Adds
3	Free Cool	CP1	CP2	CP3
4	Free Cool	CP1	CP2	CP3 + 4

**TABLE 13
FS1 GAS HEAT OPERATION
(ECTO 6.01 OPTION 12)**

Two Heat Sections With 2-Stg. Gas Valves	
Demand	Operation
W1	Low Rate, 1st Heat Section
W2	Low Rate, Both Gas Valves
W3	High Rate, 1st Heat Section Low Rate, 2nd Heat Section
W4	High Rate Both Gas Valves

**TABLE 14
FS1 ELECTRIC HEAT OPERATION
(ECTO 6.01 OPTION 12)**

Two 2-Stg. Heat Sections	
Demand	Operation
W1	Stage 1 on 1st heat section
W2	Stage 1 on both heat sections
W3	Stage 2 on 1st section, Stage 1 on 2nd section
W4	Stage 2 on both heat sections

IMPORTANT - The FS1 is not required for 4 stage operation when using the zone sensor or discharge air control modes.

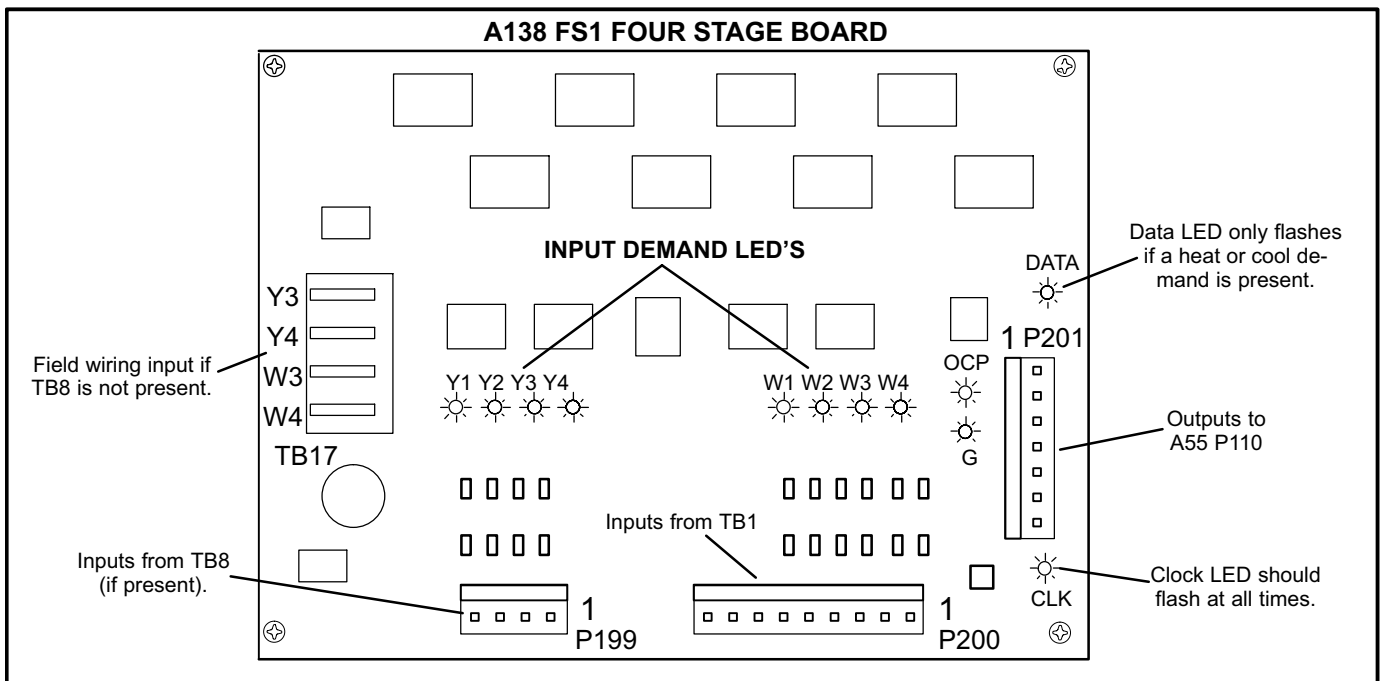

FIGURE 18

Supply Air Delivery

The supply air delivery is determined by the System Mode (ECTO 6.01) and the Supply VAV Control Mode (ECTO 0.01).

System Mode

The following examples describe blower function for constant air volume (CAV) applications.

1-Local Tstat Mode, Single Zone CAV Units

ECTO 6.01 option 0 (Default) or 12

This configuration is used for thermostat or DDC applications when the blower is controlled by the G thermostat demand 24VAC input.

Gas / Electric Units:

The blower is delayed 40 seconds (default ECTO 3.02) after the gas valve is energized and 120 seconds (default ECTO 3.03) after the gas valve is de-energized. The blower operates anytime a heat limit trips.

Electric / Electric Units:

The default on delay is set to 0 (ECTO 2.02). The blower is delayed off for 20 seconds (default ECTO2.03) after the heating demand is terminated.

Cooling Operation:

The default on and off delays are 0, but may be adjusted by ECTOs 4.02 or 4.03. The on-delay time period starts when the cooling demand is initiated. The off-delay time period starts when the cooling demand is terminated.

Heat Pump Operation:

The default on-delay is 0 (ECTO 1.02), but the off-delay default is 20 seconds (ECTO 1.03). The on-delay time period starts when the heat pump heating demand is initiated. The off-delay time period starts when the heat pump heating demand is terminated.

Summary of Blower Delays				
Unit operation	Blower On Delay		Blower Off Delay	
	Default	ECTO	Default	ECTO
Gas Heating	40 Sec.	3.02	120 Sec.	3.03
Electric Heating	0 Sec.	2.02	20 Sec.	2.03
Cooling	0 Sec.	4.02	0 Sec.	4.03
HP Heating	0 Sec.	1.02	20 Sec.	1.03

2-Zone Sensor mode, Single Zone CAV Units

ECTO 6.01 option 1,2,3

This configuration is used with an L Connection Zone sensor for single zone constant air volume application. Blower will cycle with demand unless ECTO 6.17 is set to 1. In that case the blower will operate continuously during occupied periods and will cycle with demands during unoccupied periods. All delays as described in Local Tstat Mode still apply.

Supply VAV Control Mode

The IMC uses the General Purpose GP1 board to control optional supply air and power exhaust blower variable frequency drives (VFD). The DIP switch on the GP1 board must be set to VAV. See figure 10. The GP1 controls the supply air VFD or by-pass damper in response to a duct static pressure reading. VFD powered blowers can be varied or staged.

The GP1 sensor inputs and VFD outputs are 0-10VDC.

Duct static pressure sensor (A30) is 0-5" w.c.

The IMC has a maximum supply duct pressure limit (ECTO 0.21, default 2" w.c.) If this limit is exceeded the control will shut off the unit. After an off delay time of 5 minutes (ECTO 5.02), the blower will re-energize. The control will lockout on the third trip (ECTO 0.22) and an IMC reset will be required.

The following examples describe air delivery for optional supply air VFD and by-pass damper configurations. Refer to table 15 for a summary of ECTO 0.01 options.

**TABLE 15
ECTO 0.01 SELECTION SUMMARY**

ECTO 0.01	Mode	SMK	VT	CL	HT
0	CAV	-	-	-	-
1	CAV w/bypass damper	PID	PID	PID	PID
3	VAV w/VFD	STG	STG	STG	STG
7	VAV w/VFD	PID	STG	STG	STG
11	VAV w/VFD	STG	PID	STG	STG
15	VAV w/VFD	PID	PID	STG	STG
19	VAV w/VFD	STG	STG	PID	STG
23	VAV w/VFD	PID	STG	PID	STG
27	VAV w/VFD	STG	PID	PID	STG
31	VAV w/VFD	PID	PID	PID	STG
35	VAV w/VFD	STG	STG	STG	PID
39	VAV w/VFD	PID	STG	STG	PID
43	VAV w/VFD	STG	PID	STG	PID
44	VAV w/VFD	PID	PID	STG	PID
51	VAV w/VFD	STG	STG	PID	PID
55	VAV w/VFD	PID	STG	PID	PID
59	VAV w/VFD	STG	PID	PID	PID
63	VAV w/VFD	PID	PID	PID	PID

STG=Staged Control

PID=PID Loop or Modulating Control

3-Local Tstat Mode, CAV Bypass Zoning Units

ECTO 6.01 option 0 (default) or 12

ECTO 0.01 option 1

This configuration is used for 3rd party zoning systems that utilize a blower bypass damper for controlling duct static. There are four different setpoints: one for cooling,

one for ventilation, one for operation during smoke alarm modes, and one for heating. Blower operates when the G demand is energized. The blower also operates anytime a heat limit trips. All delays as described in Local Tstat Mode still apply. The IMC controls duct static pressure by reading the duct pressure and varying the bypass damper position between minimum and maximum positions.

The min/max damper positions and static pressure setpoints are listed as follows:

Operation	Min. Position		Max. Position		Duct Static SP	
	De-fault	ECTO	De-fault	ECTO	De-fault	ECTO
Cooling	20%	0.17	100%	0.19	1.00 "w.c.	0.16
Ventilation	20%	0.17	100%	0.19	1.00 "w.c.	0.14
Smoke Alarm Modes	20%	0.17	100%	0.19	1.00 "w.c.	0.13
Heating	20%	0.18	100%	0.19	1.00 "w.c.	0.15

4-L Connection Network, CAV Bypass Zoning Units

ECTO 6.01 option 4,5,6,7

ECTO 0.01 option 1

This configuration is used for L Connection Zoning that utilizes a blower bypass damper for controlling duct static. There are four different setpoints: one for cooling, one for ventilation, one for operation during smoke alarm modes, and one for heating. Network commands energize the blower. Blower will cycle with demand unless ECTO 6.17 is set to 1. In that case, the blower will operate continuously during occupied periods and will cycle during unoccupied periods. Blower also operates anytime a heat limit trips. All delays as described in Local Tstat Mode still apply.

The IMC controls duct static pressure by reading the duct pressure and varying the bypass damper position between and minimum and maximum positions.

The min/max damper positions and static pressure setpoints are listed as follows:

Operation	Min. Position		Max. Position		Duct Static SP	
	De-fault	ECTO	De-fault	ECTO	De-fault	ECTO
Cooling	20%	0.17	100%	0.19	1.00 "w.c.	0.16
Ventilation	20%	0.17	100%	0.19	1.00 "w.c.	0.14
Smoke Alarm Modes	20%	0.17	100%	0.19	1.00 "w.c.	0.13
Heating	20%	0.18	100%	0.19	1.00 "w.c.	0.15

5-Local Tstat Mode, VAV units

ECTO 6.01 option 0 (default) or 12

ECTO 0.01 option 63

This configuration is used for 3rd party VAV zoning systems. Blower speed is controlled by the factory installed VFD between a minimum and maximum speed to maintain duct static pressure setpoints. There are four different setpoints: one for cooling, one for ventilation, one for operation during smoke alarm modes, and one for heating. The blower is enabled by a G demand. The IMC controls the duct static pressure by reading the duct pressure and varying the blower speed on units with VFDs.

The min/max speed and static pressure setpoints are listed as follows:

Operation	Min. Speed		Max. Speed		Duct Static SP	
	De-fault	ECTO	De-fault	ECTO	De-fault	ECTO
Cooling	50%	0.06	100%	0.08	1.00 "w.c.	0.05
Ventilation	50%	0.06	100%	0.08	1.00 "w.c.	0.03
Smoke Alarm Modes	50%	0.06	100%	0.08	1.00 "w.c.	0.02
Heating	50%	0.07	100%	0.08	1.00 "w.c.	0.04

6-Local Tstat Mode, VAV staged units

ECTO 6.01 option 0 (default) or 12

ECTO 0.01 option 3

This configuration is a special case application where the blower speed is staged by the factory installed VFD for fixed speeds for different operation. There are seven different speed stages, one for each cooling stage (4), one for ventilation, one for heating and one for operation during smoke alarm modes. The blower is enabled by a G demand.

The min/max and staged speeds are listed as follows:

Operation	Staged Speed	
	(1)Default	ECTO
Cooling 1	51%	0.05
Cooling 2	51%	0.14
Cooling 3	51%	0.15
Cooling 4	51%	0.16
Ventilation	51%	0.03
Smoke Alarm Modes	51%	0.02
Heating	51%	0.04

(1)Staged % speed must be adjusted for each operation.

7-L Connection Network, VAV units

ECTO 6.01 option 4, 5, 6, or 7

ECTO 0.01 option 63

This configuration is used for L Connection VAV zoning systems. There are four different setpoints: one for cooling, one for ventilation, one for operation during smoke alarm modes, and one for heating. Network commands energize the blower. Blower will cycle with demand unless ECTO 6.17 is set to 1. In that case the blower will operate continuously during occupied periods and will cycle during unoccupied periods. Network commands controls occupied/unoccupied periods.

All delays as described in Local Tstat Mode still apply. Blower speed is controlled by the factory installed VFD between a minimum and maximum speed to maintain duct static pressure setpoints. There are three different setpoints, one for cooling, one for ventilation and one for operation during smoke alarm modes. The IMC controls the duct static pressure by reading the duct pressure and varying the blower speed on units with VFDs

The min/max. speed and static pressure setpoints are listed below:

Operation	Min. Speed		Max. Speed		Duct Static SP	
	De-fault	ECTO	De-fault	ECTO	De-fault	ECTO
Cooling	50%	0.06	100%	0.08	1.00 "w.c.	0.05
Ventilation	50%	0.06	100%	0.08	1.00 "w.c.	0.03
Smoke Alarm Modes	50%	0.06	100%	0.08	1.00 "w.c.	0.02
Heating	50%	0.07	100%	0.08	1.00 "w.c.	0.04

8-L Connection Network, VAV Staged Units

ECTO 6.01 option 4,5,6,7

ECTO 0.01 option 3

This configuration is a special case application where the blower speed is staged by the factory installed VFD for fixed speeds for different operation. There are seven different speed stages, one for each cooling stage (4), one for ventilation, one for heating and one for operation during smoke alarm modes. Network commands energize the blower. Blower will cycle with demand unless ECTO 6.17 is set to 1. In that case the blower will operate continuously during occupied periods and will cycle during unoccupied periods. Network commands controls occupied/unoccupied periods.

Operation	Staged Speed	
	(1)Default	ECTO
Cooling 1	51%	0.05
Cooling 2	51%	0.14
Cooling 3	51%	0.15
Cooling 4	51%	0.16
Ventilation	51%	0.03
Smoke Alarm Modes	51%	0.02
Heating	51%	0.04

(1)Staged % speed must be adjusted for each operation.

VFD Control

The IMC is only compatible with the factory installed variable frequency drives (VFD) in VAV units used to control the supply blower and exhaust fan(s). The analog control for the VFDs is 0-10VDC. This manual uses percent (%) for all blower and fan speeds. For example, 50% blower speed equals 30Hz equals 5VDC.

Speed %	Motor Frequency (Hz)	VFD Control Voltage (VDC)
0	0	0
10	6	1
20	12	2
30	18	3
40	24	4
50	30	5
60	36	6
70	42	7
80	48	8
90	54	9
100	60	10

Supply Bypass Damper Control

The IMC is only compatible with bypass damper actuators specified in the Engineering Handbook. Specified dampers are used to control the supply air volume for constant air volume w/bypass damper (CAVB) zoning applications. The analog control for the actuator is a 2-10VDC with 10VDC being fully closed. This manual uses percent (%) for bypass damper position. For example, 70% bypass damper position equals 4.4VDC.

Bypass Damper Position (%)	Control Voltage (VDC)
0 (closed)	10
10	9.2
20	8.4
30	7.6
40	6.8
50	6.0
60	5.2
70	4.4
80	3.6
90	2.8
100	2.0

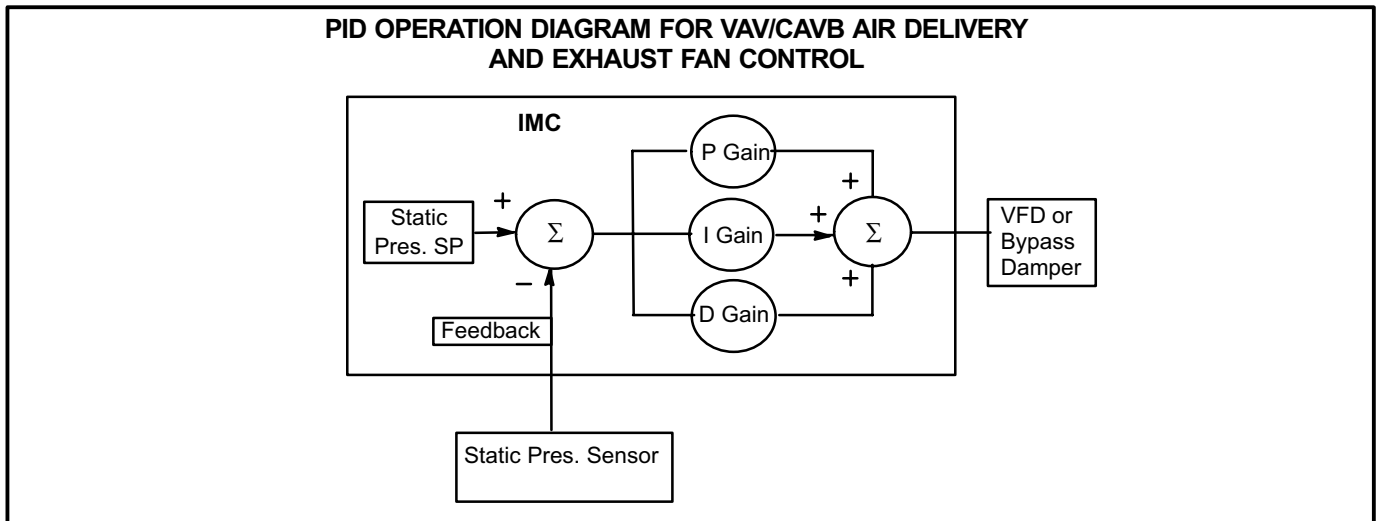

FIGURE 19

Analog Output Control

The analog outputs on the GP1 boards can be set to closed loop PID or staged control. Most applications such as variable air delivery and variable speed exhaust fans will use the closed loop PID option. The closed loop PID method used by the IMC has four constants, manual reset (ManRS), proportional (P), integral (I) and derivative (D) as shown in figure 19. The PID control constants as well as the output minimum and maximum values, may be adjusted if necessary.

Manual Reset (ManRS)- The output value when the P, I, and D values are all 0. This is the approximate output expected which allows quicker settling at setpoint. On CAV units with bypass damper, this is also the damper position when blower is off. ManRS can be adjusted between a minimum value and 100%.

Proportional Constant (P) –*To handle the present*, this is the value of the “gain” that is multiplied times the error. The error is the difference between the output and the setpoint. A large value of “P” will cause the output to reach the setpoint faster, however, this faster rate can cause the output to overshoot the setpoint. On the other hand, a low value of “P” will reduce overshoot, but will cause the output reaction to be too slow. **The “P” constant ECTO value can be adjusted between 0 –127 with 0 being off and 127 being the highest value.**

Integral Constant (I)- *To handle the past*, this gain is proportional to the amount of time that the error is present. This gain tries to integrate out any offset. A high value of

“I” can provide fast correction but can cause overshoot and ringing. The “I” gain should be set to the lowest value possible that corrects the offset. “I” can be adjusted between 0-127 with 127 being the lowest value. **The “I” constant ECTO value is inverted. A value of 0 turns the integral factor off. A value of 127 is the minimum and 1 is the maximum.**

Derivative Constant (D)- *To handle the future*, this gain is proportional to the rate of change of the error and provides a damping factor. **The “D” constant ECTO value can be adjusted between 0- 127 with 0 being off and 127 being the highest value. Most IMC applications do not require using any “D” gain.**

Tuning

In the event that the PID loop requires tuning, the following two methods are recommended depending on the severity of the problem:

- 1- In most cases the parameters will only need a small adjustment or tweaking. In that case use the following table as a basic guide.
- 2- If method 1 tweaking does not stabilize the system, you may use the following tuning method:

Note: To use this method the system must be allowed to operate at the manual reset value (% output) without damaging the system.

- 3- Set the P, I and D constants to 0 (off).
- 4- Start system. Analog output value will be at the ManRS value (%).

Change Desired	ECTO “P” Parameter	ECTO “I” Parameter	ECTO “D” Parameter
Reduce Response time	Increase	Decrease	Decrease
Reduce Overshoot	Decrease	Increase	Increase
Reduce Settling Time	-	Decrease	Decrease
Reduce Offset (steady state error)	Increase	Decrease	-

- 5- Monitor system. System should be stable. If system is not stable at this point check for other problems. Adjusting the PID parameters will not solve this problem.
- 6- If system is stable, gradually increase the “P” parameter until system starts oscillating (moving above and below setpoint, continuously).
- 7- Reduce the “P” parameter to 40-70% of the value set in step 6.

- 8- Gradually start adding some “I” by setting the “I” ECTO parameter to 127 and reduce setting until the steady state error (offset) is reduced to an acceptable level.
- 9- If necessary, increase the “D” parameter to reduce overshoot. Use of “D” can increase settling time and/or lead to instability. **(Note: Most cases its best not to use any “D”).**

Summary Of PID Constants ECTO Parameters						
Variable Air Delivery PID Constants						
No.	Name	Min	Default	Max	Units	Description
0.09	VAV_PID_ManRS	0 0	60 60	100 100	Counts P:%	VAV supply PID manual reset value. If minimum output, ECTO 0.06 or 0.07 is greater, a computed ManRS value is used. See ECTO 0.06 and 0.07.
0.10	PID_P_Constant	0	17	127	Counts	VAV or CAVB supply PID Proportional constant.
0.11	PID_I_Constant	0	12	127	Counts	VAV or CAVB supply PID Integral constant.
0.12	PID_D_Constant	0	0	127	Counts	VAV or CAVB supply PID derivative constant.
VAV Exhaust Fan PID Control Constants						
8.22	Exh_Fan_ManRS	0 0	50 50	100 100	Counts P: %	Exhaust fan PID loop manual reset value.
	Stg_1_Off_Delay	0	100	200	A:Sec.	Stage 1 off-delay. (Only used for 2 stage operation)
8.23	Exh_Fan_PID_P_Constant	0	20	255	Counts	Exhaust fan PID loop proportional constant. The P constant must be limited to 127. Recommended setting = 17.
	Stg_2_SP	0 0 -0.5	.78 20 -42	10.0 100 0.5	R:Volts P:% M:"w.c.	Staged 2 setpoint.
8.24	Exh_Fan_PID_I_Constant	0	64	255	Counts	Exhaust fan PID loop integral constant. The I constant must be limited to 127. Recommended setting = 12.
	Stg_2_DB	0 0	64 0.25	100 1.0	P:% L:"w.c.	Staged 2 deadband.
8.25	Exh_Fan_PID_D_Constant	0	0	127	Counts	Exhaust fan PID loop derivative constant.
	Stg_2_On_Delay	0	0	254	A: Sec.	Staged 2 on-delay.
General Purpose PID Control Constants for GP Analog Output 1 (TB22-11)						
9.08	AO1_PID_ManRS	0 0	50 50	100 100	Counts P:%	Analog output channel 1 PID loop manual reset value.
9.09	AO1_PID_P_Constant	0	0	127	Counts	Analog output channel 1 PID loop proportional constant.
9.10	AO1_PID_I_Constant	0	0	127	Counts	Analog output channel 1 PID loop integral constant.
9.11	AO1_PID_D_Constant	0	0	127	Counts	Analog output channel 1 PID loop derivative constant.
General Purpose PID Control Constants for GP Analog Output 2 (TB22-12)						
9.19	AO2_PID_ManRS	0 0	50 50	100 100	Counts P:%	Analog output channel 2 PID loop manual reset value.
9.20	AO2_PID_P_Constant	0	0	127	Counts	Analog output channel 2 PID loop proportional constant.
9.21	AO2_PID_I_Constant	0	0	127	Counts	Analog output channel 2 PID loop integral constant.
9.22	AO2_PID_D_Constant	0	0	127	Counts	Analog output channel 2 PID loop derivative constant.

Reheat Operation

GENERAL

Reheat is a combination of cooling to dehumidify and heating to maintain space temperature. Supermarket reheat uses gas heat and Humiditrol® units route hot gas to a reheat coil downstream of the evaporator. A gas heat unit is required for Supermarket Reheat and a Humiditrol® unit is required for Humiditrol Reheat. Economizer operation is disabled during reheat operation except for Supermarket Reheat operation ECTO 4.24 option 1.

SUPERMARKET REHEAT OPERATION

ECTO 4.24 Option 1 De-Humidistat Control

IMPORTANT - Supermarket Reheat is allowed on gas/electric units only; not electric/electric or heat pump units.

A de-humidistat will bring on first-stage cooling to dehumidify and a room thermostat will energize heating to maintain indoor temperature. To disable free cooling in this mode, select economizer global mode (figure 34) but do not connect the global input (TB1-1).

An optional de-humidistat is required. Refer to figure 20.

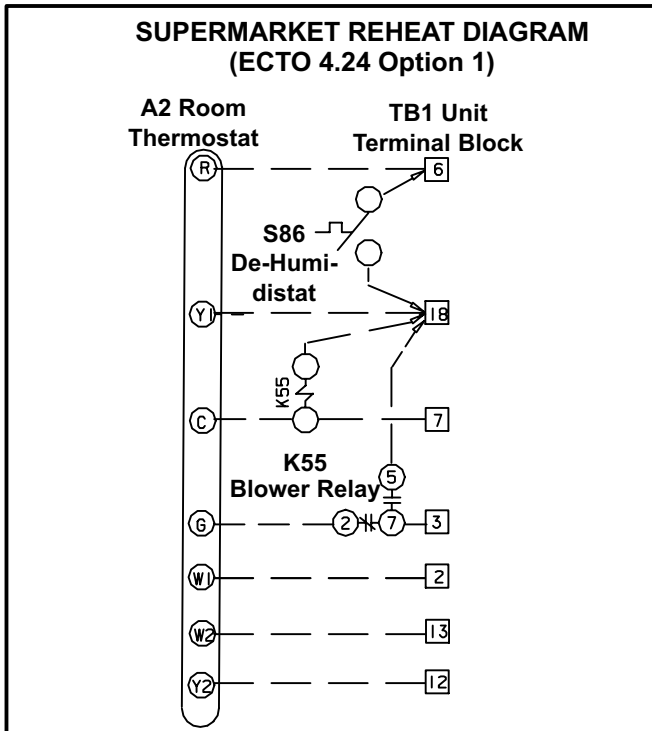

FIGURE 20

ECTO 4.24 Option 2 RH Sensor Control

A relative humidity sensor will bring on first-stage cooling based on the setpoint set with ECTO 4.25 or from the L Connection network. First-stage cooling will de-energize when RH drops to ECTO 4.25 minus 4.26. A room

thermostat or zone sensor will energize heating to maintain indoor temperature.

An optional RH sensor is required. Refer to figure 21.

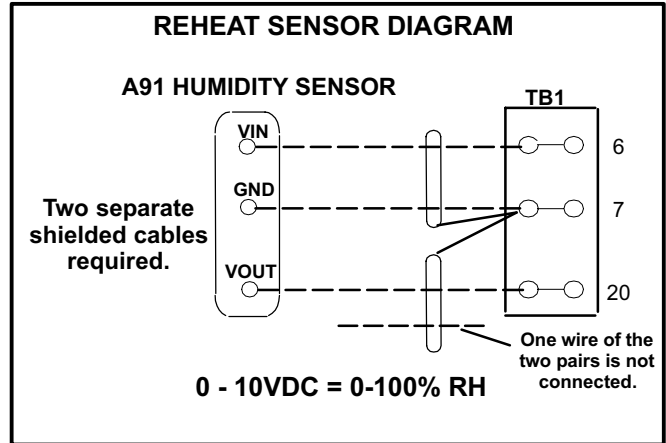

FIGURE 21

HUMIDITROL REHEAT OPERATION

A relative humidity sensor will energize first-stage compressor(s) and hot gas will be routed to the reheat coil based on the setpoint set with ECTO 4.25 or from the L Connection network. The following options show additional conditions which must be met before reheat will be energized:

ECTO 4.24 option 3

- Blower energized.
- Occupied time period.
- One previous cooling demand must have occurred.

ECTO 4.24 option 5

- One previous cooling demand must have occurred.

ECTO 4.24 option 6

- Blower energized.
- Occupied time period.

ECTO 4.24 option 7

- No additional conditions.

Humiditrol reheat will de-energize when the RH drops to ECTO 4.25 minus 4.26. An optional RH sensor is required. See figure 21. See tables 19 through 24 for reheat compressor staging. Shaded rows indicate reheat operation.

HUMIDITROL REHEAT OPERATION - DIGITAL

ECTO 4.24 Set to 100

Humiditrol reheat is controlled by the digital input A67_P175-5 (TB1-24) only. The input signal will energize compressor(s) and reheat solenoid. Connect wiring to TB1 as shown in figure 22. See tables 19 through 24 for reheat compressor staging.

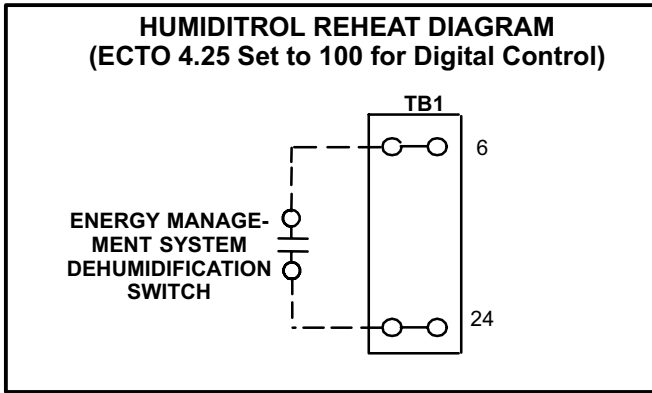

FIGURE 22

RH MEASUREMENT / DISPLAY

ECTO 4.24 option 4

When an optional relative humidity sensor is installed, the % RH can be displayed on the IMC readout and over the L Connection network via the NCP and/or PC software. Option 4 is NOT used to control Humiditrol or Supermarket Reheat. Option 4 may be used for outside air dehumidification. Refer to figure 21.

OUTSIDE AIR FOR DEHUMIDIFICATION

The IMC has an option that allows FAT heated outside air to be used to dehumidify when outside air temperature is low. When ECTO 4.24 is set to options 2-7, outside air will be used for dehumidification instead of the compressor. When the outside air temperature is less than setpoint,

ECTO 7.04 must be set to 70°F or less to enable this option. Additional conditions for operation apply. See to table 16.

The IMC will use the gas or electric heat to temper discharge air and the outside air will be used to dehumidify (when there is a dehumidification demand and outside air is cool). Adjust the following settings:

- ECTO 7.02 Outdoor Air Setpoint (50°F typical)
- ECTO 7.03 Damper Position (40% typical)
- ECTO 7.04 Fresh Air Heating Reheat Setpoint (65F typical)

This option can be used with ECTO 4.24 options 2-7 only - not with option 1.

Refer to table 18.

**TABLE 16
OUTSIDE AIR FOR DEHUMIDIFICATION CONDITIONS**

ECTO 4.24 Option	Outside Air Dehumidification Conditions
1	Not allowed.
2	Allowed. No conditions apply.
3	Allowed, blower must be energized and in occupied mode. No previous cooling demand is required.
4	Allowed. Must be occupied.
5	Allowed, blower must be energized and in occupied mode. No previous cooling demand is required.
6	Allowed. No conditions apply.
7	Allowed. No conditions apply.

**TABLE 17
SUMMARY OF REHEAT ECTO OPTIONS**

No.	Name	Min	Default	Max	Units	Description
4.24	Reheat_Control	0	0	7	Option	Reheat Control Mode 0- No reheat. 1- Supermarket reheat using De-Humidistat (Tstat mode only) 2- Supermarket reheat using RH sensor. 3- Humiditrol reheat. Conditions: Blower must be energized, Must be occupied, At least one previous cooling demand. 4- RH measurement / display. No Supermarket or Humiditrol reheat. 5- Humiditrol reheat. Conditions: At least one previous cooling demand. 6- Humiditrol reheat. Conditions: Blower must be energized, Must be occupied. 7- Humiditrol reheat. Conditions: None
4.25	Reheat_SP	0 0	60 60	100 100	Counts P:%RH	Percent relative humidity where supermarket or Humiditrol reheat demand is energized. Used of Reheat option 2,3,5,6, or 7. Reheat is de-energized at setpoint – deadband (ECTO 4.26). If value = 100, Humiditrol reheat is controlled by the digital input A67_P175-5 (TB1-24) only. Energized input signal calls for reheat demand. L Connection Network RH setpoint will override this setpoint. (Such as from NCP).
4.26	Reheat_RH_DB	1 1	3 3	10 10	Counts P:%RH	Reheat RH deadband. Used of Reheat option 2,3,5,6, or 7. Reheat is on when RH >= ECTO 4.25 and off when RH < ECTO 4.25 – ECTO 4.26.

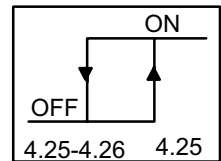

REHEAT

TABLE 18

Outside Air For Dehumidification Parameters

7.02	Reheat_FAH_OAT_SP	113 60	136 45	175 20	Counts Y:DegF	Outdoor air temperature setpoint that enables fresh air heating for reheat demand and opens damper to ECTO 7.03 when outdoor air is less than setpoint.
7.03	Reheat_FAH_%_Damper	5 5	40 40	100 100	Counts P:%	Fresh air damper position during Fresh Air Heating reheat operation.
7.04	Reheat_FAH_SP	139 70	138 Disabled	183 40	Counts X:DegF	Fresh Air Heating Reheat setpoint. Minimum value of 138 disables FAH-Reheat.

TABLE 19

ONE COMPRESSOR HUMIDITROL DEFAULT OPERATION USING A TWO-STAGE THERMOSTAT OR ZONE SENSOR

REHEAT

Demands			Unit Operation			
T'Stat or Zone Sensor	Economizer	Dehumidification	Free Cooling On	CP1 On	Reheat Valve 1 On	Summary
						Idle.
		X		X	X	CP1 Reheat (Reheat Stage 1)
	X	X		X	X	CP1 Reheat (Reheat Stage 1)
1st				X		CP1 Cool
1st	X		X			Free Cool
1st		X		X		CP1 Cool
1st	X	X		X		CP1 Cool
2nd				X		CP1 Cool
2nd	X		X	X		Free Cool, CP1 Cool
2nd		X		X		CP1 Cool
2nd	X	X		X		CP1 Cool

Free cooling operation is only available on units equipped with an economizer. Default dehumidification demand = RH (A91) > 60% (RH setpoint ECTO 4.25). Optional dehumidification demand = TB1-24 energized if ECTO 4.25 is set to 100 (digital demand). Heating demand overrides reheat.

**TABLE 20
TWO COMPRESSOR HUMIDITROL DEFAULT OPERATION USING
A TWO-STAGE THERMOSTAT OR ZONE SENSOR**

Demands				Unit Operation					Summary
T'Stat	Zone Sensor	Economizer	Dehumidification	Free Cooling On	CP1 On	CP2 On	Reheat Valve 1 On		
								Idle.	
			X		X		X	CP1 Reheat (Reheat Stage 1)	
		X	X		X		X	CP1 Reheat (Reheat Stage 1)	
1st	1st				X			CP1 Cool	
1st	1st	X		X	X			Free Cool	
1st	1st		X		X	X	X	CP1 Reheat, CP2 Cool (Reheat Stage 2)	
1st	1st	X	X		X	X	X	CP1 Reheat, CP2 Cool (Reheat Stage 2)	
2nd	2nd				X	X		CP1 Cool, CP2 Cool	
2nd	2nd	X		X	X			Free Cool, CP1 Cool	
2nd	2nd		X		X	X		CP1 Cool, CP2 Cool	
2nd	2nd	X	X		X	X		CP1 Cool, CP2 Cool	
N/A	3rd				X	X		CP1 Cool, CP2 Cool	
N/A	3rd	X		X	X	X		Free Cool, CP1 Cool, CP2 Cool	
N/A	3rd		X		X	X		CP1 Cool, CP2 Cool	
N/A	3rd	X	X		X	X		CP1 Cool, CP2 Cool	

Free cooling operation is only available on units equipped with an economizer. Default dehumidification demand = RH (A91) > 60% (RH setpoint ECTO 4.25). Optional dehumidification demand = TB1-24 energized if ECTO 4.25 is set to 100 (digital demand). Heating demand overrides reheat.

**TABLE 21
THREE COMPRESSOR HUMIDITROL DEFAULT OPERATION USING
A TWO-STAGE THERMOSTAT**

Demands			Unit Operation						Summary
T'Stat	Economizer	Dehumidification	Free Cooling On	CP1 On	CP2 On	CP3 On	Reheat Valve 1 On	Reheat Valve 2 On	
									Idle.
		X		X	X		X	X	CP1 Reheat, CP2 Reheat (Reheat Stage 1)
	X	X		X	X		X	X	CP1 Reheat, CP2 Reheat (Reheat Stage 1)
1st				X	x				CP1 Cool, CP2 Cool
1st	X		X						Free Cool
1st		X		X	X	X	X	X	CP1 Reheat, CP2 Reheat, CP3 Cool (Reheat Stage 2)
1st	X	X		X	X	X	X	X	CP1 Reheat, CP2 Reheat, CP3 Cool (Reheat Stage 2)
2nd				X	X	X			CP1 Cool, CP2 Cool, CP3 Cool
2nd	X		X	X	X				Free Cool, CP1 Cool, CP2 Cool
2nd		X		X	X	X			CP1 Cool, CP2 Cool, CP3 Cool
2nd	X	X		X	X	X			CP1 Cool, CP2 Cool, CP3 Cool

Free cooling operation is only available on units equipped with an economizer. Default dehumidification demand = RH (A91) > 60% (RH setpoint ECTO 4.25). Optional dehumidification demand = TB1-24 energized if ECTO 4.25 is set to 100 (digital demand). Heating demand overrides reheat.

REHEAT

**TABLE 22
THREE COMPRESSOR HUMIDITROL DEFAULT OPERATION USING
A FOUR-STAGE THERMOSTAT (DDC) WITH FS1 BOARD OR ZONE SENSOR**

Demands			Unit Operation						
T'Stat DDC, or Zone Sensor	Economizer	Dehumidification	Free Cooling On	CP1 On	CP2 On	CP3 On	Reheat Valve 1 On	Reheat Valve 2 On	Summary
									Idle.
		X		X	X		X	X	CP1 Reheat, CP2 Reheat (Reheat Stage 1)
	X	X		X	X		X	X	CP1 Reheat, CP2 Reheat (Reheat Stage 1)
1st				X	X				CP1 Cool
1st	X		X						Free Cool
1st		X		X	X	X	X	X	CP1 Reheat, CP2 Reheat, CP3 Cool (Reheat Stage 2)
1st	X	X		X	X	X	X	X	CP1 Reheat, CP2 Reheat, CP3 Cool (Reheat Stage 2)
2nd				X	X	X			CP1 Cool, CP2 Cool
2nd	X		X	X					Free Cool, CP1 Cool
2nd		X		X	X				CP1 Cool, CP2 Cool
2nd	X	X		X	X				CP1 Cool, CP2 Cool
3rd				X	X	X			CP1 Cool, CP2 Cool, CP3 Cool
3rd	X		X	X	X				Free Cool, CP1 Cool, CP2 Cool
3rd		X		X	X	X			CP1 Cool, CP2 Cool, CP3 Cool
3rd	X	X		X	X	X			CP1 Cool, CP2 Cool, CP3 Cool
4th				X	X	X			CP1 Cool, CP2 Cool, CP3 Cool
4th	X		X	X	X	X			Free Cool, CP1 Cool, CP2 Cool, CP3 Cool
4th		X		X	X	X			CP1 Cool, CP2 Cool, CP3 Cool
4th	X	X		X	X	X			CP1 Cool, CP2 Cool, CP3 Cool

Free cooling operation is only available on units equipped with an economizer. Default dehumidification demand = RH (A91) > 60% (RH setpoint ECTO 4.25). Optional dehumidification demand = TB1-24 energized if ECTO 4.25 is set to 100 (digital demand). Heating demand overrides reheat.

**TABLE 23
FOUR COMPRESSOR HUMIDITROL DEFAULT OPERATION USING
A TWO-STAGE THERMOSTAT**

Demands			Unit Operation							
T'Stat	Econo-mizer	Dehumidification	Free Cooling On	CP1 On	CP2 On	CP3 On	CP4 On	Reheat Valve 1 On	Reheat Valve 2 On	Summary
										Idle.
		X		X	X			X	X	CP1 Reheat, CP2 Reheat (Reheat Stage 1)
	X	X		X	X			X	X	CP1 Reheat, CP2 Reheat (Reheat Stage 1)
1st				X	X					CP1 Cool, CP2 Cool
1st	X		X							Free Cool
1st		X		X	X	X	X	X	X	CP1 Reheat, CP2 Reheat, CP3 Cool, CP4 Cool (Reheat Stage 2)
1st	X	X		X	X	X	X	X	X	CP1 Reheat, CP2 Reheat, CP3 Cool, CP4 Cool (Reheat Stage 2)
2nd				X	X	X	X			CP1 Cool, CP2 Cool, CP3 Cool, CP4 Cool
2nd	X		X	X	X					Free Cool, CP1 Cool, CP2 Cool
2nd		X		X	X	X	X			CP1 Cool, CP2 Cool, CP3 Cool, CP4 Cool
2nd	X	X		X	X	X	X			CP1 Cool, CP2 Cool, CP3 Cool, CP4 Cool

Free cooling operation is only available on units equipped with an economizer. Default dehumidification demand = RH (A91) > 60% (RH setpoint ECTO 4.25). Optional dehumidification demand = TB1-24 energized if ECTO 4.25 is set to 100 (digital demand). Heating demand overrides reheat.

REHEAT

**TABLE 24
FOUR COMPRESSOR HUMIDITROL DEFAULT OPERATION USING
FOUR-STAGE THERMOSTAT (DDC) WITH FS1 BOARD OR ZONE SENSOR**

Demands			Unit Operation							
T'Stat, DDC, or Zone Sensor	Econo-mizer	Dehumidification	Free Cooling On	CP1 On	CP2 On	CP3 On	CP4 On	Reheat Valve 1 On	Reheat Valve 2 On	Summary
										Idle.
		X		X	X			X	X	CP1 Reheat, CP2 Reheat (Reheat Stage 1)
	X	X		X	X			X	X	CP1 Reheat, CP2 Reheat (Reheat Stage 1)
1st				X						CP1 Cool
1st	X		X							Free Cool
1st		X		X	X	X		X	X	CP1 Reheat, CP2 Reheat, CP3 Cool (Reheat Stage 2)
1st	X	X		X	X	X		X	X	CP1 Reheat, CP2 Reheat, CP3 Cool (Reheat Stage 2)
2nd				X	X					CP1 Cool, CP2 Cool
2nd	X		X	X						Free Cool, CP1 Cool
2nd		X		X	X	X	X	X	X	CP1 Reheat, CP2 Reheat, CP3 Cool, CP4 Cool (Reheat Stage 3)
2nd	X	X		X	X	X	X	X	X	CP1 Reheat, CP2 Reheat, CP3 Cool, CP4 Cool (Reheat Stage 3)
3rd				X	X	X				CP1 Cool, CP2 Cool, CP3 Cool
3rd	X		X	X	X					Free Cool, CP1 Cool, CP2 Cool
3rd		X		X	X	X				CP1 Cool, CP2 Cool, CP3 Cool
3rd	X	X		X	X	X				CP1 Cool, CP2 Cool, CP3 Cool
4th				X	X	X	X			CP1 Cool, CP2 Cool, CP3 Cool, CP4 Cool
4th	X		X	X	X	X	X			Free Cool, CP1 Cool, CP2 Cool, CP3 Cool, CP4 Cool
4th		X		X	X	X	X			CP1 Cool, CP2 Cool, CP3 Cool, CP4 Cool
4th	X	X		X	X	X	X			CP1 Cool, CP2 Cool, CP3 Cool, CP4 Cool

Free cooling operation is only available on units equipped with an economizer. Default dehumidification demand = RH (A91) > 60% (RH setpoint ECTO 4.25). Optional dehumidification demand = TB1-24 energized if ECTO 4.25 is set to 100 (digital demand).

REHEAT

Fresh Air Tempering Mode (FAT)

Fresh air tempering is used in applications with large outdoor air requirements to reduce temperature fluctuations in the conditioned space.

The IMC tempers discharge air by heating or cooling in response to the discharge duct temperature, RT6. Standard heating and cooling demands override FAT heating and cooling demands.

IMPORTANT - For FAT modes to operate properly, RT6 discharge sensor must be relocated to supply air duct.

Adjust ECTO 6.20 to enable fresh air heating (FAH) and ECTO 7.06 to enable fresh air cooling (FAC).

Heating is energized when discharge air temperature falls below FAH setpoint (60°F typical). Cooling is

energized when discharge air temperature rises above FAC setpoint (80°F typical). Heat pump units operate only one stage of electric heat during FAH mode instead of compressors. FAT will operate up to four stages of heating and cooling to maintain discharge air temperature.

FAC will terminate when the return air temperature is less than 60°F. If ECTO 5.05 is set to 1, FAC will terminate when the return air temperature is less than 65°F default (ECTO 5.07).

FAH will terminate when the return air temperature is greater than 80°F. If ECTO 5.05 is set to 1, FAH will terminate when the RAT is greater than 85°F (ECTO 5.06).

Figure 23 illustrates stages of fresh air tempering operation. Refer to table 25 for ECTO parameters.

**TABLE 25
FRESH AIR TEMPERING ECTO SUMMARY**

Fresh Air Heating (FAH) Parameters						
Control Parameter		Control Value			Units	Description
No.	Name	Min	Default	Max.		
6.20	FAH_SP	139 70	138 Disabled	183 40	Counts X:DegF	Fresh Air Heating setpoint. To enable FAH, set this to a value between 40F (183) and 70F(139). Minimum value (138) disables Fresh Air Heating.
6.21	FAH_Stg_DB	7 5	15 10	22 15	Counts V:DegF	Fresh Air Heating stage deadband.
6.22	FAH_Min_Cycle_Time	15 120	60 480	225 180 0	Counts C:Sec	Fresh Air heating minimum cycle time.
7.01	FAH_Stg_Diff	0 0	3 2	30 20	Counts V:DegF	Fresh Air Heating stage differential. 0 value for first stage heating only for Fresh Air Heating.
7.13	DACH_ & FAH_StgUp_Delay	0 0	45 180	225 900	Counts B: Sec.	Discharge Air Control Heating and Fresh Air Heating stage-up time delay.
7.14	DACH_ & FAH_StgDn_Delay	0 0	30 120	150 600	Counts B: Sec.	Discharge Air Control Heating and Fresh Air Heating stage-down time delay.
Fresh Air Cooling (FAC) Parameters						
7.05	FAT_Auto-change_Delay	28 896	56 1792	225 7200	Counts D: Sec.	Fresh air Tempering (FAH or FAC) auto-changeover delay.
7.06	FAC_SP	109 90	108 Disabled	154 60	Counts X:DegF	Fresh Air Cooling setpoint. To enable FAC, set this to a value between 60F (154) and 90F(109). Minimum value of 91F (108) disables FAC.
7.07	FAC_Stg_DB	7 5	15 10	22 15	Counts V:DegF	Fresh Air Cooling stage deadband.
7.08	FAC_Min_Cycle	15 120	60 480	225 1800	Counts C: Sec.	Fresh Air Cooling minimum cycle time.
7.09	FAC_Stg_Diff	0 0	3 2	30 20	Counts V:DegF	Fresh Air Cooling stage differential between stages. Set to 0 for first stage cooling only for Fresh Air Cooling.
7.19	DACC_ & FAC_StgUp_Delay	0 0	45 180	225 900	Counts B: Sec.	Discharge Air Control Cooling and Fresh Air Cooling stage-up delay.
7.20	DACC_ & FAC_StgDn_Delay	0 0	30 120	150 600	Counts B: Sec.	Discharge Air Control Cooling and Fresh Air Cooling stage-down time delay.

FRESH AIR TEMPERING (FAT) STAGES Default Values Shown

Note - MGV units modulate the gas valves to control FAH.

FAC stage-up delay is adjusted by ECTO 7.19 (default = 3 minutes).
 FAC stage-down delay is adjusted by ECTO 7.20 (default = 2 minutes).
 FAC minimum cycle time is adjusted by ECTO 7.08 (default 8 minutes).
 All compressor minimum run delays apply.

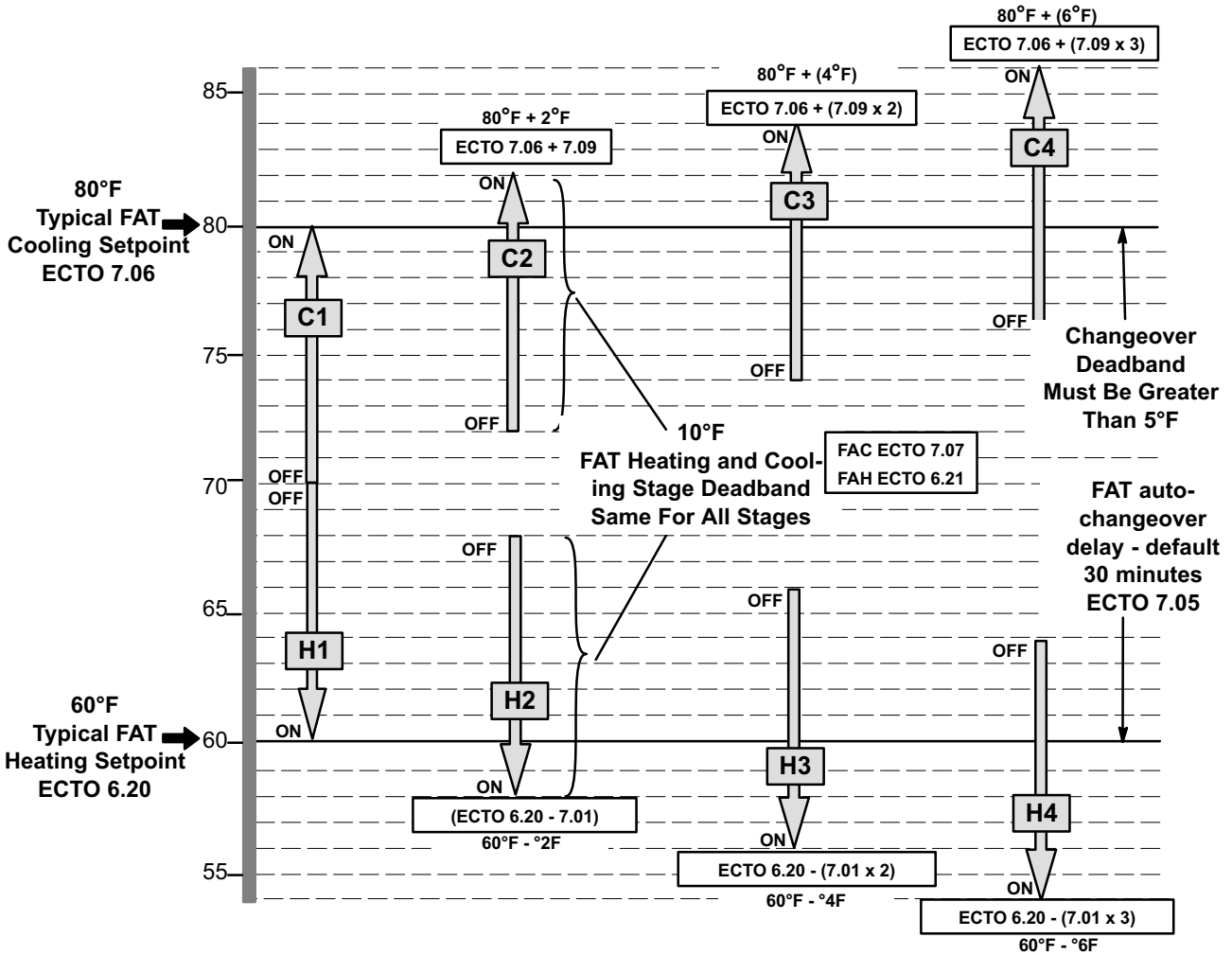

FAH stage-up delay is adjusted by ECTO 7.13 (default = 3 minutes).
 FAH stage-down delay is adjusted by ECTO 7.14 (default = 2 minutes).
 FAH minimum cycle time is adjusted by ECTO 6.22 (default 8 minutes).
 Heat pumps operate only one stage of electric heat during FAH.
 All heating delays apply.

FIGURE 23

Discharge Air Control

Cooling

The discharge air control cooling (DACC) option automatically cycles up to 4 stages of cooling to maintain a discharge air control cooling setpoint (DACC_SP).

DACC option applies to gas/electric and electric /electric units only; DACC is not allowed with heat pumps units.

When an economizer is installed, adjust free cooling setpoint ECTO 6.23 approximately 2 degrees lower than DACC setpoint. This will allow free cooling to operate before DACC energizes compressors.

Refer to figure 24 for DACC cooling stages.

Adjust ECTO 5.04 to option 4 to enable discharge air control cooling.

IMPORTANT - Discharge air sensor RT6 must be moved to the supply air duct, preferably after a 90 degree branch of the main duct.

DACC is initiated by an input in one of three ways:

- 1- Y1 input from an external device-
ECTO 6.01 must be set to 0, local thermostat mode.
- 2- Cooling demand while in zone sensor mode-
ECTO 6.01 must be set to 1, 2, or 3.
- 3- L Connection network command-
ECTO 6.01 must be set to 4, 5, 6 or 7.

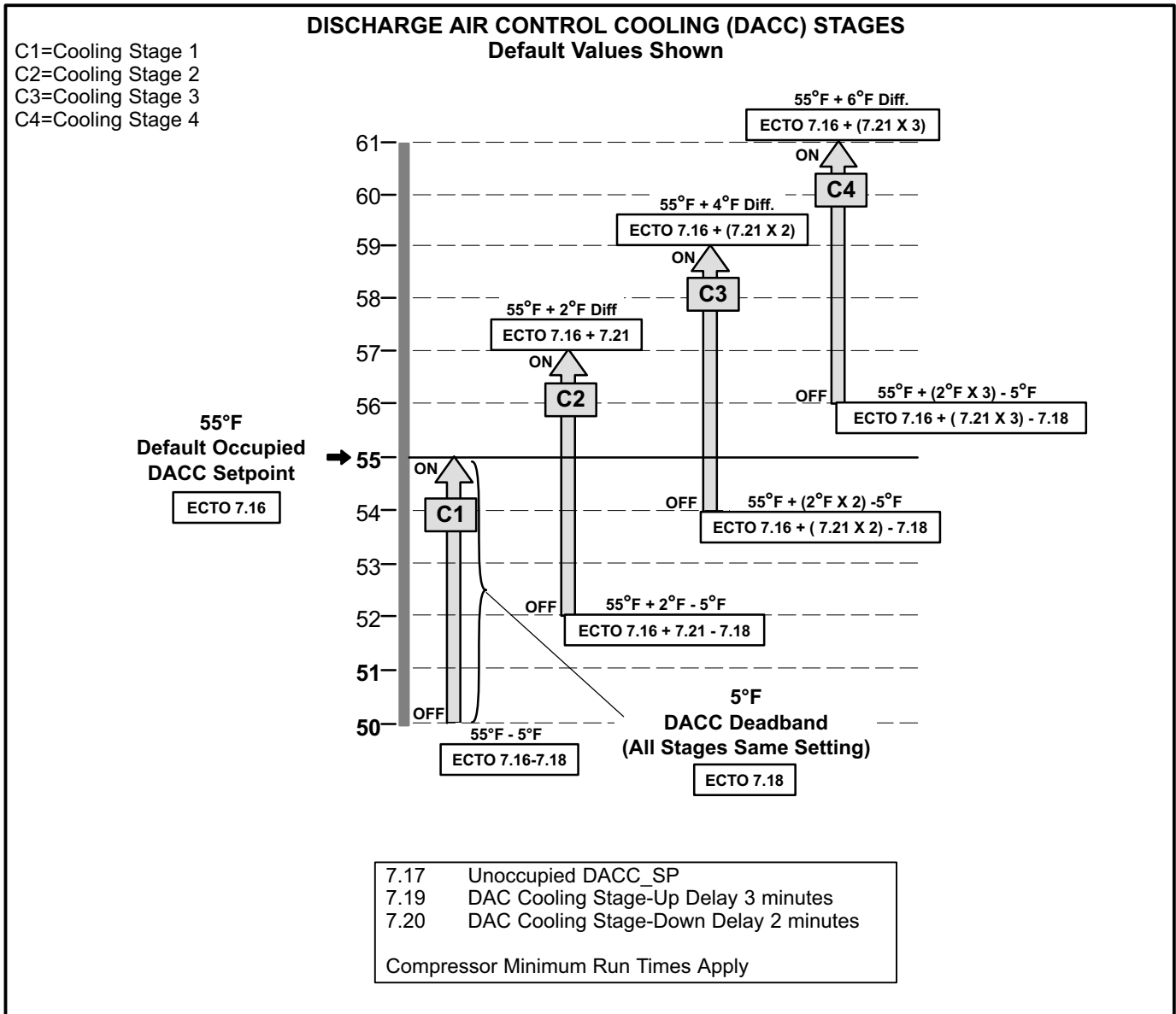

FIGURE 24

Outdoor Air Reset

Important - Outdoor air reset can be used to adjust the free cooling setpoint (ECTO 6.23) when DACC is not used. All references to the DACC setpoint apply to the free cooling setpoint.

The DACC and free cooling setpoint can be automatically reset when outdoor air temperature becomes cooler. Use ECTO 8.07 to enable Outdoor Air Reset.

For outdoor air based DACC setpoint reset, the discharge air cooling setpoint starts to increase when the outdoor air temperature (OAT) drops to the DACC_OAT_RS_SP (ECTO 8.05) (default 80°F). The reset setpoint will continue to increase at the rate equal to the DACC_OAT_RS_Adjustment_Band (ECTO 8.07) divided by the DACC_OAT_RS_Proportional_Band (ECTO 8.06). See the following example:

Example: The application calls for the discharge air cooling occupied setpoint (DACC_OCP_SP) (ECTO 7.16) to be 55°F when OAT is 80°F or higher. When the OAT drops below 80°F, the setpoint needs to increase proportionately with the OAT decrease (maximum setpoint increase of 10°F). The 10°F OAT decrease is called the DACC_OAT_RS_Proportional_Band and the setpoint increase of 10°F is called the DACC_OAT_RS_Adjustment_Band. See figure 25.

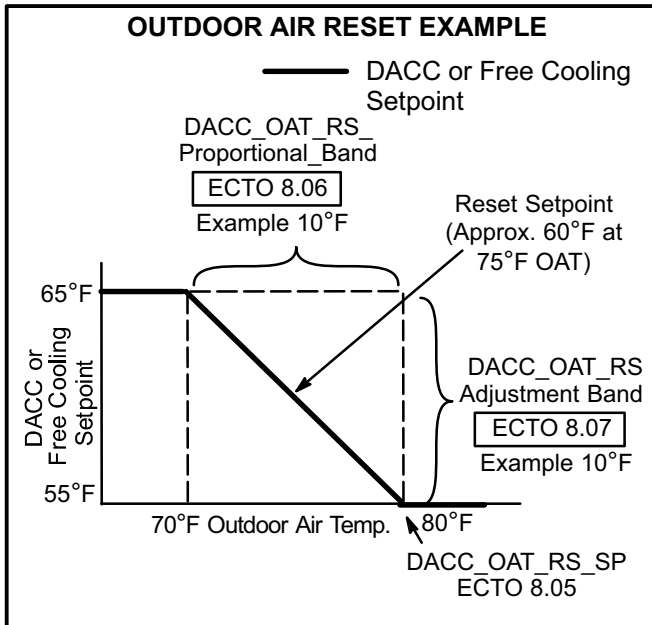

FIGURE 25

To use example values, set the following parameters:

- ECTO 8.05 – DACC OAT RS SP – Set to 80°F
- ECTO 8.06 – DACC OAT RS Proportional Band – Set to 10°F
- ECTO 8.07 – DACC OAT RS Adjustment Band – Set to 10°F (this setting enables DACC outdoor air reset).

Return Air Reset

Important - Return air reset can be used to adjust the free cooling setpoint (ECTO 6.23) when DACC is not used. All references to the DACC setpoint apply to the free cooling setpoint.

The DACC and free cooling setpoint can be automatically reset when return air temperature becomes cooler. Use ECTO 8.04 to enable Return Air Reset.

For return air based DACC setpoint reset, the discharge air cooling setpoint starts to increase when the return air temperature (RAT) drops to the DACC_RAT_RS_SP (ECTO 8.02) (default 70°F). The reset setpoint will continue to increase at the rate equal to the DACC_RAT_RS_Adjustment_Band (ECTO 8.04) divided by the DACC_RAT_RS_Proportional_Band (ECTO 8.03). See the following example:

Example: The application calls for the discharge air occupied setpoint (DACC_OCP_SP) (ECTO 7.16) to be 55°F when RAT is 70°F or higher. When the RAT drops below 70°F, the setpoint needs to increase proportionately with the OAT decrease (maximum setpoint increase of 10°F). The 10°F RAT difference is called the DACC_RAT_RS_Proportional_Band and the setpoint increase of 10°F is called the DACC_RAT_RS_Adjustment_Band. See figure 26.

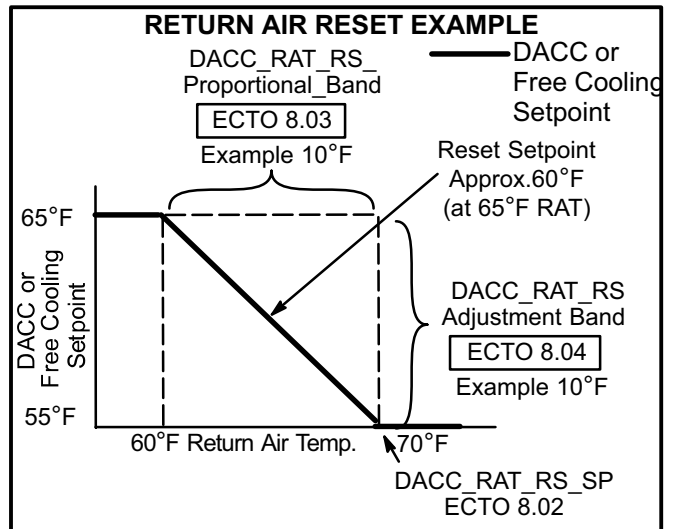

FIGURE 26

To use example values, set the following parameters:

- ECTO 8.02 – DACC_RAT_RS_SP – Set to 70°F
- ECTO 8.03 – DACC_RAT_RS_Proportional_Band – Set to 10°F
- ECTO 8.04 – DACC_RAT_RS_Adjustment_Band - Set to 10°F (this setting enables DACC return air reset).

Discharge Air Cooling Total Reset Limit

ECTO 8.01 (default=10) defines the total DACC setpoint reset limit. This total limit is the sum of both return and outdoor DACC resets. This parameter limits total DACC_SP adjustment band and overrides the adjustment bands for RAT and OAT (ECTO 8.07 & 8.04) if necessary.

Discharge Air Cooling ECTO Parameters Summary

Control Parameter		Control Value			Units	Description																																										
No.	Name	Min	Default	Max.																																												
5.04	CL_Staging	0	2	4	Option	Cooling staging options: 0: No cooling operation 1: Basic Tstat operation. Two cooling stages. Units with Economizers Y1=Free Cooling, Y2=adds all mechanical stages. 2: Basic Tstat operation. Two cooling stages. Units with Economizers Y1=Free Cooling, Y2= adds first stage of mechanical. 3: Basic Tstat operation. Three cooling stages. Y1 only = first stage, Y2 only = second stage, Y1+Y2 = third stage. Units with Economizers Y2 only adds first stage of mechanical, Y1+Y2 adds first and second stage of mechanical. 4: Discharge air control. Up to four stages.																																										
6.01	System_Mode	0	0	12	Option	System mode of operation. <table border="1"> <thead> <tr> <th>Control Value</th> <th>System Mode</th> <th>Backup Mode</th> </tr> </thead> <tbody> <tr><td>0</td><td>Local Thermostat</td><td>None</td></tr> <tr><td>1</td><td>Zone Sensor</td><td>None</td></tr> <tr><td>2</td><td>Zone Sensor</td><td>Local Thermostat</td></tr> <tr><td>3</td><td>Zone Sensor</td><td>Return Air Sensor</td></tr> <tr><td>4</td><td>Remote Demand</td><td>None</td></tr> <tr><td>5</td><td>Remote Demand</td><td>Local Thermostat</td></tr> <tr><td>6</td><td>Remote Demand</td><td>Return Air Sensor</td></tr> <tr><td>7</td><td>Remote Demand</td><td>Zone Sensor</td></tr> <tr><td>8</td><td>Future Use</td><td>None</td></tr> <tr><td>9</td><td>Future Use</td><td>Local Thermostat</td></tr> <tr><td>10</td><td>Future Use</td><td>Return Air Sensor</td></tr> <tr><td>11</td><td>Future Use</td><td>Zone Sensor</td></tr> <tr><td>12</td><td>A138 4-Stg. Tstat Interface</td><td>None</td></tr> </tbody> </table>	Control Value	System Mode	Backup Mode	0	Local Thermostat	None	1	Zone Sensor	None	2	Zone Sensor	Local Thermostat	3	Zone Sensor	Return Air Sensor	4	Remote Demand	None	5	Remote Demand	Local Thermostat	6	Remote Demand	Return Air Sensor	7	Remote Demand	Zone Sensor	8	Future Use	None	9	Future Use	Local Thermostat	10	Future Use	Return Air Sensor	11	Future Use	Zone Sensor	12	A138 4-Stg. Tstat Interface	None
Control Value	System Mode	Backup Mode																																														
0	Local Thermostat	None																																														
1	Zone Sensor	None																																														
2	Zone Sensor	Local Thermostat																																														
3	Zone Sensor	Return Air Sensor																																														
4	Remote Demand	None																																														
5	Remote Demand	Local Thermostat																																														
6	Remote Demand	Return Air Sensor																																														
7	Remote Demand	Zone Sensor																																														
8	Future Use	None																																														
9	Future Use	Local Thermostat																																														
10	Future Use	Return Air Sensor																																														
11	Future Use	Zone Sensor																																														
12	A138 4-Stg. Tstat Interface	None																																														
7.16	DACC_OCP_SP	124 80	161 55	183 40	Counts	Discharge Air Control Cooling setpoint during occupied period.																																										
7.17	DACC_UnOCP_SP	124 80	146 65	183 40	Counts X:DegF	Discharge Air Control Cooling setpoint during unoccupied period.																																										
7.18	DACC_Stg_DB	7 5	7 5	30 20	Counts V:DegF	Discharge Air Control Cooling stage deadband.																																										
7.19	DACC_&_FAC_StgUp_Delay	0 0	45 180	225 900	Counts B: Sec.	Discharge Air Control Cooling and Fresh Air Cooling stage-up delay.																																										
7.20	DACC_&_FAC_StgDn_Delay	0 0	30 120	150 600	Counts B: Sec.	Discharge Air Control Cooling and Fresh Air Cooling stage-down time delay.																																										
7.21	DACC_Stg_Diff	3 2	3 2	30 20	Counts V:DegF	Discharge Air Cooling stage differential.																																										
8.01	DACC_RS_Total_LT	7 5	15 10	29 20	Counts V:DegF	Discharge Air Control Cooling total reset limit. This limits the total DACC reset allowed. Also used to reset free cooling setpoint (6.23).																																										
8.02	DACC_RAT_RS_SP	124 80	139 70	169 50	Counts X:DegF	Discharge Air Control Cooling return air reset setpoint. Also used to reset free cooling setpoint (6.23).																																										
8.03	DACC_RAT_RS_Proportional_Band.	1 1	15 10	44 30	Counts V:DegF	Discharge Air Control Cooling return air reset proportional band. Also used to reset free cooling setpoint (6.23).																																										
8.04	DACC_RAT_RS_Adjust_Band	0 0	0 0	44 30	Counts V:DegF	Discharge Air Control Cooling return air reset adjustment band. 0 disables return air cooling reset. Also used to reset free cooling setpoint (6.23).																																										
8.05	DACC_OAT_RS_SP	50 100	81 80	144 40	Counts Y:DegF	Discharge Air Control Cooling outdoor air temperature cooling reset setpoint. Also used to reset free cooling setpoint (6.23).																																										
8.06	DACC_OAT_RS_Proportional_Band.	1 1	31 20	94 60	Counts O:DegF	Discharge Air Control Cooling outdoor ambient temperature cooling proportional band. Also used to reset free cooling setpoint (6.23).																																										
8.07	DACC_OAT_RS_Adjust_Band	0 0	0 0	47 30	Counts O:DegF	Discharge Air Control Cooling outdoor temperature ambient cooling adjustment reset band. 0 disables outdoor air cooling reset. Also used to reset free cooling setpoint (6.23).																																										

Heating

The discharge air control heating (DACH) option automatically cycles up to 4 stages of heating to maintain a discharge air control heating setpoint (DACH_SP).

DACH option applies to gas/electric and electric /electric units only; DACH is not allowed with heat pumps units.

Refer to figure 27 for DACH heating stages.

Adjust ECTO 5.09 to option 1 to enable discharge air control.

IMPORTANT - Discharge air sensor RT6 must be moved to the supply air duct, preferably after a 90 degree branch off of the main duct.

DACH is initiated by an input in one of three ways:

- 1- W1 input from an external device-
ECTO 6.01 must be set to 0, local thermostat mode.
- 2- Heating demand while in zone sensor mode-
ECTO 6.01 must be set to 1, 2, or 3.
- 3- L Connection network command-
ECTO 6.01 must be set to 4, 5, 6 or 7.

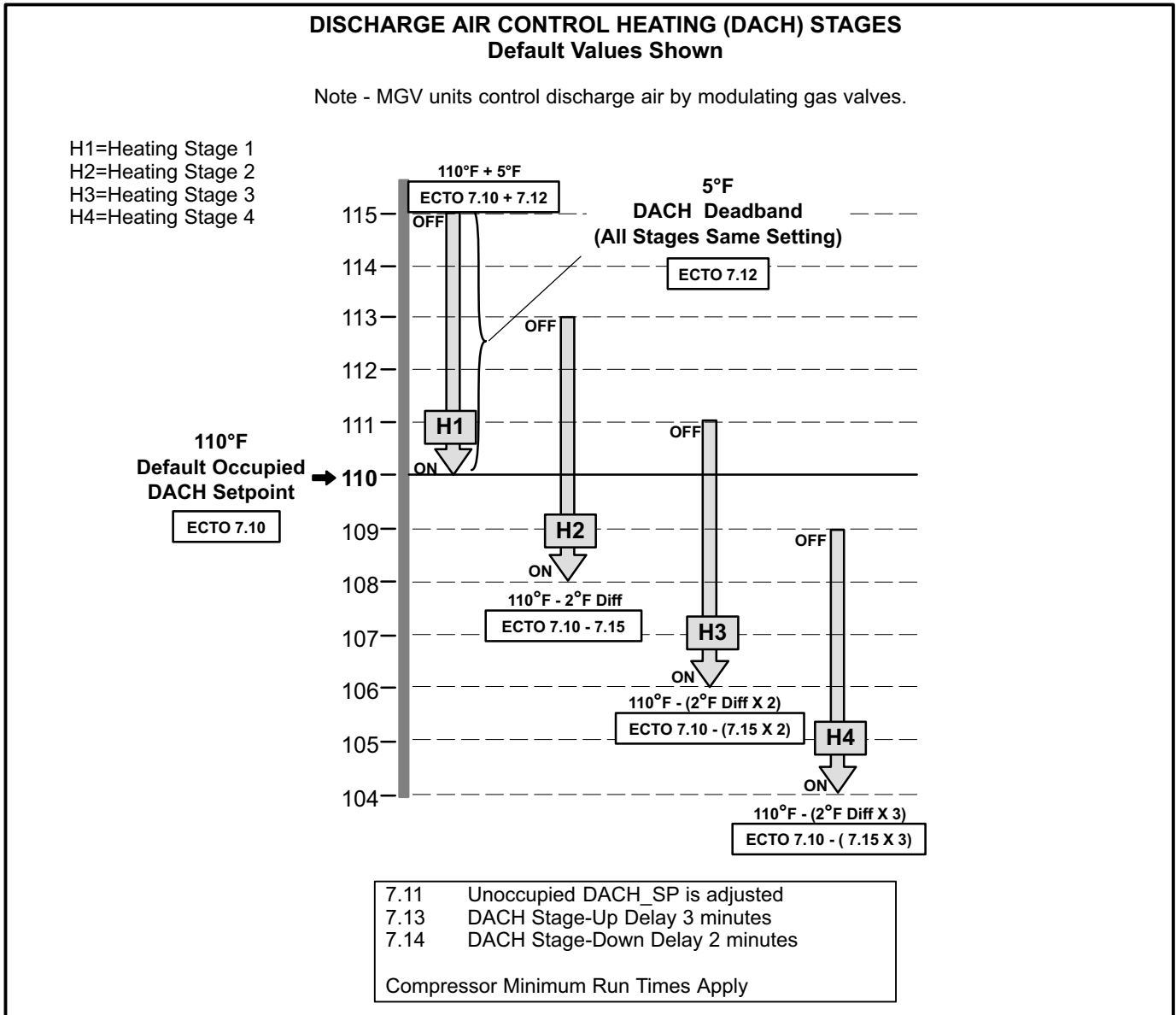

FIGURE 27

Outdoor Air Reset

The DACH setpoint can be automatically reset when outdoor air temperature becomes warmer.

For outdoor air based DACH setpoint reset, the discharge air control heating setpoint starts to decrease when the outdoor air temperature (OAT) rises to the DACH_OAT_RS_SP (ECTO 8.12) (default 40°F). The reset setpoint will continue to decrease at the rate equal to the DACH_OAT_RS_Adjustment_Band (ECTO 8.14) divided by the DACH_OAT_RS_Proportional_Band (ECTO 8.13). See the following example:

Example: The application calls for the discharge air control heating occupied setpoint (DACH_OCP_SP) (ECTO 7.10) to be 110°F when OAT is 40°F or lower. When the OAT rises above 40°F, the setpoint needs to decrease proportionately with the OAT increase (maximum setpoint increase of 10°F). The 10°F OAT decrease is called the DACH_OAT_RS_Proportional_Band and the setpoint decrease of 10°F is called the DACH_OAT_RS_Adjustment_Band. See figure 28.

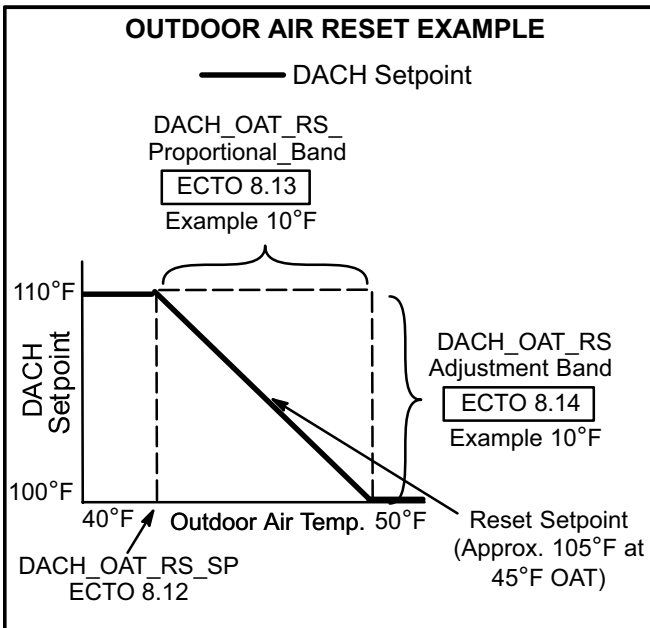

FIGURE 28

To use example values, set the following parameters:

- ECTO 8.12 – DACH OAT RS SP – Set to 40°F
- ECTO 8.13 – DACH OAT RS Proportional Band – Set to 10°F
- ECTO 8.14 – DACH OAT RS Adjustment Band -- Set to 10°F (this setting enables DACH outdoor air reset).

Return Air Reset

The DACH setpoint can be automatically reset when return air temperature becomes warmer.

For return air based DACH setpoint reset, the discharge air control heating setpoint starts to decrease when the return air temperature (RAT) rises to the DACH_RAT_RS_SP (ECTO 8.09) (default 70°F). The reset setpoint will continue to decrease at the rate equal to the DACH_RAT_RS_Adjustment_Band (ECTO 8.11) divided by the DACH_RAT_RS_Proportional_Band (ECTO 8.10). See the following example:

Example: The application calls for the discharge air control heating occupied setpoint (DACH_OCP_SP) (ECTO 7.10) to be 110°F when RAT is 70°F or lower. When the RAT increases above 70°F, the setpoint needs to decrease proportionately with the RAT increase (maximum setpoint increase of 10°F). The 10°F RAT difference is called the DACH_RAT_RS_Proportional_Band and the setpoint increase of 10°F is called the DACH_RAT_RS_Adjustment_Band. See figure 29.

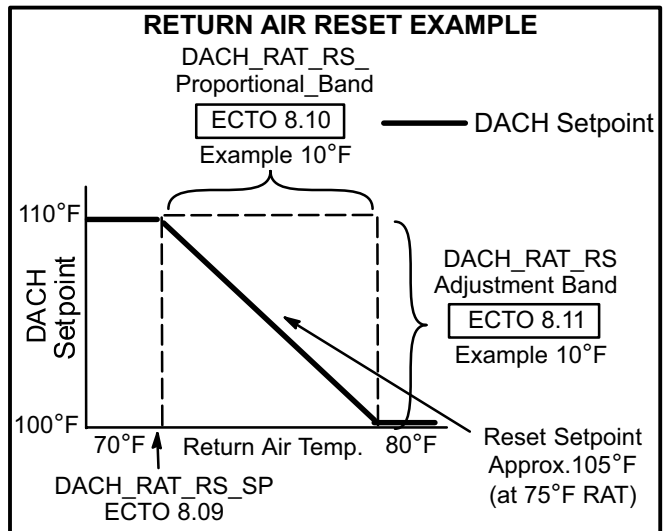

FIGURE 29

To use example values, set the following parameters:

- ECTO 8.09 – DACH_RAT_RS_SP – Set to 70°F
- ECTO 8.10 – DACH_RAT_RS_Proportional_Band – Set to 10°F
- ECTO 8.11 – DACH_RAT_RS_Adjustment_Band - Set to 10°F (this setting enables DACH return air reset).

Discharge Air Control Heating Total Reset Limit

ECTO 8.08 (default=10) defines the total DACH setpoint reset limit. This total limit is the sum of both return and outdoor DACH resets. This parameter limits total DACH_SP adjustment band and overrides the adjustment bands for RAT and OAT (ECTO 8.11 & 8.14) if necessary.

Discharge Air Heating ECTO Parameters Summary																																																
Control Parameter		Control Value			Units	Description																																										
No.	Name	Min	Default	Max.																																												
5.09	HT_Staging	0	2	2	Option	Heating staging options: 0- No heating operation. 1- Discharge air control with up to 4 stages. 2- Thermostat operation.																																										
6.01	System_Mode	0	0	12	Option	System mode of operation. <table border="1"> <thead> <tr> <th>Control Value</th> <th>System Mode</th> <th>Backup Mode</th> </tr> </thead> <tbody> <tr><td>0</td><td>Local Thermostat</td><td>None</td></tr> <tr><td>1</td><td>Zone Sensor</td><td>None</td></tr> <tr><td>2</td><td>Zone Sensor</td><td>Local Thermostat</td></tr> <tr><td>3</td><td>Zone Sensor</td><td>Return Air Sensor</td></tr> <tr><td>4</td><td>Remote Demand</td><td>None</td></tr> <tr><td>5</td><td>Remote Demand</td><td>Local Thermostat</td></tr> <tr><td>6</td><td>Remote Demand</td><td>Return Air Sensor</td></tr> <tr><td>7</td><td>Remote Demand</td><td>Zone Sensor</td></tr> <tr><td>8</td><td>Future Use</td><td>None</td></tr> <tr><td>9</td><td>Future Use</td><td>Local Thermostat</td></tr> <tr><td>10</td><td>Future Use</td><td>Return Air Sensor</td></tr> <tr><td>11</td><td>Future Use</td><td>Zone Sensor</td></tr> <tr><td>12</td><td>A138 4-Stg. Tstat Interface</td><td>None</td></tr> </tbody> </table>	Control Value	System Mode	Backup Mode	0	Local Thermostat	None	1	Zone Sensor	None	2	Zone Sensor	Local Thermostat	3	Zone Sensor	Return Air Sensor	4	Remote Demand	None	5	Remote Demand	Local Thermostat	6	Remote Demand	Return Air Sensor	7	Remote Demand	Zone Sensor	8	Future Use	None	9	Future Use	Local Thermostat	10	Future Use	Return Air Sensor	11	Future Use	Zone Sensor	12	A138 4-Stg. Tstat Interface	None
Control Value	System Mode	Backup Mode																																														
0	Local Thermostat	None																																														
1	Zone Sensor	None																																														
2	Zone Sensor	Local Thermostat																																														
3	Zone Sensor	Return Air Sensor																																														
4	Remote Demand	None																																														
5	Remote Demand	Local Thermostat																																														
6	Remote Demand	Return Air Sensor																																														
7	Remote Demand	Zone Sensor																																														
8	Future Use	None																																														
9	Future Use	Local Thermostat																																														
10	Future Use	Return Air Sensor																																														
11	Future Use	Zone Sensor																																														
12	A138 4-Stg. Tstat Interface	None																																														
7.10	DACH_OCP_SP	36 140	80 110	124 80	Counts X:DegF	Discharge Air Control Heating setpoint during occupied period.																																										
7.11	DACH_Un-OCP_SP	36 140	95 100	124 80	Counts X:DegF	Discharge Air Control Heating setpoint during unoccupied period.																																										
7.12	DACH_Stg_DB	7 5	7 5	30 20	Counts V:DegF	Discharge Air Control Heating deadband.																																										
7.13	DACH_&_FAH_StgUp_Delay	0 0	45 180	225 900	Counts B: Sec.	Discharge Air Control Heating and Fresh Air Heating stage-up time delay.																																										
7.14	DACH_&_FAH_StgDn_Delay	0 0	30 120	150 600	Counts B: Sec.	Discharge Air Control Heating and Fresh Air Heating stage-down time delay.																																										
7.15	DACH_Stg_Diff	3 2	3 2	30 20	Counts V:DegF	Discharge Air Control Heating stage differential																																										
8.08	DACH_RS_Limit	7 5	15 10	29 20	Counts V:DegF	0 Discharge Air Control Heating reset limit. This limits the total DACH reset allowed. 0																																										
8.09	DACH_RAT_RS_SP.	124 80	139 70	169 50	Counts X:DegF	Discharge Air Control Heating return air heating reset setpoint.																																										
8.10	DACH_RAT_RS_Proportional_Band	1 1	15 10	44 30	Counts V:DegF	Discharge Air Control Heating return air heating reset proportional band.																																										
8.11	DACH_RAT_RS_Adjust_Band	0 0	0 0	44 30	Counts V:DegF	Discharge Air Control Heating return reset adjustment band. 0 value disables return air heating reset.																																										
8.12	DACH_OAT_RS_SP	113 60	144 40	255 -31	Counts Y:DegF	Discharge Air Control Heating outdoor temperature reset setpoint.																																										
8.13	DACH_OAT_RS_Proportional_Band.	1 1	31 20	94 60	Counts O:DegF	Discharge Air Control Heating temperature reset proportional band.																																										
8.14	DACH_OAT_RS_Adjust_Band	0 0	0 0	47 30	Counts O:DegF	Discharge Air Control Heating outdoor temperature reset adjustment band. 0 disables outdoor temperature heating reset																																										

Modulating Gas Valve (MGV)

Units equipped with optional modulating gas valves (MGV) contain two modulating gas valves in addition to two standard gas valves.

Operation

The IMC will control modulating gas valves to maintain 110°F (default) discharge air during the heating cycle. The left heat section will operate when 25-50% of nameplate heat is needed. Both heat sections will operate when 50-100% of the nameplate heat is needed.

The normally open MGV will allow full heating capacity should the MGV fail.

Testing

- 1- Operate the unit in heating mode.
- 2- Turn the OPT1 and OPT2 switches ON. See figure 30. The unit will operate at maximum heating input after ECTO 3.05 delay (default 30 seconds).
- 3- Turn the OPT2 switch OFF. The unit will operate at minimum heating input.
- 4- Turn OPT1 switch OFF.

NOTE - BOTH OPT1 AND OPT2 SWITCHES MUST BE OFF FOR NORMAL UNIT OPERATION.

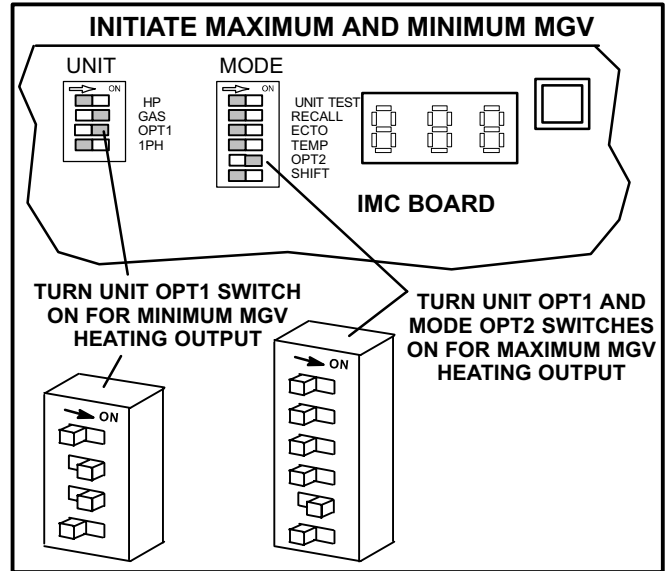
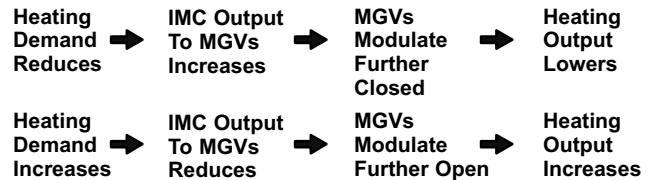

FIGURE 30

IMC Output

The IMC 0-10VDC output to the MGVs increases to modulate valves further closed during a reduced heating demand. The IMC 0-10VDC output to the MGVs decreases to modulate valves further open during a higher heating demand.



Load Shedding Options

The IMC may be setup to de-energize half of the mechanical cooling provided by a rooftop unit. A digital input to either the (A56) economizer board or the (A133) GP1 board is required. This option is set by adjusting ECTO 7.25. See table 26. The option selects the digital input used and determines which compressors are shed on units equipped with 1 or 3 (odd) compressors. See table 27.

To shut down the whole unit, digital input A55_P110_9 (TB1-23) (A42) can be de-energized.

The M1-7 readout will display "LS" when the unit is in load shedding mode.

TABLE 26

Options	Digital Input (energized for load shedding)
2 or 3	A56_P115_4 (TB1-1)
4 or 5	A133_P194-1 (TB22-1) (A133 DIP set to GP)
6 or 7	A133_P194-2 (TB22-2) (A133 DIP set to GP)
8 or 9	A133_P194-1 (TB19-1) (A133 DIP set to MGv)
10 or 11	A133_P194-2 (TB19-2) (A133 DIP set to MGv)
12 or 13	A133_P194-1 (TB18-1) (A133 DIP set to VAV)
14 or 15	A133_P194-2 (TB18-2) (A133 DIP set to VAV)

TABLE 27

Unit Size	Compressors Disabled By Option 2, 4, 6, 8, 10, 12, 14	Compressors Disabled By Option 3, 5, 7, 9, 11, 13, 15
1 Compressor	None	CP1
2 Compressors	CP2	CP2
3 Compressors	CP3	CP2 & CP3
4 Compressors	CP3 & CP4	CP3 & CP4

Power Exhaust Operation

Single Fan or Blower

The IMC has several exhaust control options selected by ECTO 8.16. The default operation, option 0, is single-stage energized when the fresh air damper opens to 50% Travel (ECTO 8.20). The blower must be operating.

Units equipped with an A133 (GP) board with the DIP configuration switch set to VAV, may control the fan by a building pressure switch (S37 or S39) or a pressure transducer (A34).

Two Fans or Blowers

Units equipped with two-stage exhaust fan and A133 (GP) board with the DIP configuration switch set to VAV, may control the fan stage by two fresh air damper position setpoints, two pressure switches or from two pressure sensor setpoints.

Exhaust Blower VFD

Units equipped with a power exhaust VFD and A133 (GP) board with the DIP configuration switch set to VAV, may vary the speed of the blower to maintain a building pressure setpoint.

There are four exhaust fan enable options to choose from when the unit is equipped with a GP board:

- 1- On when blower is energized.
- 2- On always.
- 3- On during occupied period.
- 4- On if optional digital input A133_P194_1 (TB18-1) is energized.

See table 28 for more details.

TABLE 28
ECTO 8.16 EXHAUST CONTROL

Single Stage Exhaust						
Option ECTO 8.16	Enabled when	Input	Setpoint		Deadband	
			Default	ECTO	Default	ECTO
0	Blower is energized	Fresh Air Damper Position	50% Travel	8.20	10% Travel	8.21
CAV units with single stage exhaust fans use the A56_P115-3 output to energize the exhaust relay when the fresh air damper position reaches 50% Travel (ECTO 8.20) when the blower is operating. The exhaust will de-energize when the damper position decreases 10% (ECTO 8.21) less than the setpoint or when the blower is de-energized. VAV units with VFDs could use this option for single stage operation. In that case, the A56_P115-3 output is used to enable the VFD and the exhaust fan will operate at speed set with ECTO 8.17 (50% default).						
1	Always	A133 Digital Input 1 (P194-1)(TB18-1) (Pressure Switch S37)	Input energized by pressure switch setting.			
2	Occupied	A133 Digital Input 1 (P194-1)(TB18-1) (Pressure Switch S37)	Input energized by pressure switch setting.			
3	Blower is energized.	A133 Digital Input 1 (P194-1)(TB18-1) (Pressure Switch S37)	Input energized by pressure switch setting.			
On units equipped with an A133 board set for VAV operation, the exhaust fan will be energized when enabled and the Digital Input 1 is energized. This option typically would have a building pressure switch connected to the Digital Input. VAV units with VFDs could use this option for single stage operation. In that case, the A56_P115-3 output is used to enable the VFD and the exhaust fan will operate at speed set with ECTO 8.17 (50% default).						
4	Always	A133 Analog Input 2 (P194-7) (TB18-7) (Pressure Sensor A34)	-0.3"w.c. ⁽¹⁾	8.20	0.04"w.c. ⁽¹⁾	8.21
5	Occupied	A133 Analog Input 2 (P194-7) (TB18-7) (Pressure Sensor A34)	-0.3"w.c. ⁽¹⁾	8.20	0.04"w.c. ⁽¹⁾	8.21
6	Blower is energized	A133 Analog Input 2 (P194-7) (TB18-7) (Pressure Sensor A34)	-0.3"w.c. ⁽¹⁾	8.20	0.04"w.c. ⁽¹⁾	8.21
7	A133 Digital Input 1 (P194-1) is energized (enable switch)	A133 Analog Input 2 (P194-7) (TB18-7) (Pressure Sensor A34)	-0.3"w.c. ⁽¹⁾	8.20	0.04"w.c. ⁽¹⁾	8.21
⁽¹⁾ Settings require adjustment in most cases. CAV units equipped with an A133 board set for VAV operation, the power exhaust will be energized when enabled and the Analog Input voltage is at or above ECTO 8.20 setting. Exhaust air will de-energize when the voltage decreases by the deadband set with ECTO 8.21. This option typically would have a building pressure sensor connected to the Analog Input. VAV units with VFDs could use this option for single stage operation. In that case, the A56_P115-3 output is used to enable the VFD and the exhaust fan will operate at speed set with ECTO 8.17 (50% default)						

ECTO 8.16 EXHAUST CONTROL - Continued

Two-Stage Exhaust											
Option	Enabled when	Input 1	Input 2	Setpoint 1		Deadband 1		Setpoint 2		Deadband 2	
				De-fault	ECTO	De-fault	ECTO	De-fault	ECTO	De-fault	ECTO
8	Blower is energized	Fresh Air Damper Position	Fresh Air Damper Position	50% Travel	8.20	10% Travel	8.21	20% Travel (1)	8.23	64% Travel(1)	8.24

(1) Settings must be adjusted for proper operation.
 Units equipped with an A133 board set for VAV operation and two-stage exhaust fans use the A56_P115-3 output to energize the exhaust relay for stage one when the fresh air damper position reaches 50% Travel (ECTO 8.20) when the blower is operating. The A133_P194-5 output energizes exhaust fan relay (K201) for stage two when the fresh air damper position reaches (ECTO 8.23) when the blower is operating. ECTO 8.23 must be adjusted for this operation. Stage 2 will de-energize when the damper position decreases the % set with ECTO 8.24 less than the setpoint or when the blower is de-energized. Stage two will not energize until 0 seconds default (ECTO 8.25) after stage one. Stage 1 will not de-energize until stage two has been de-energized for 100 Seconds (ECTO8.22).

9	Always	A133 Digital Input 1 (P194-1)(TB18-1) (Pressure Switch S37)	A133 Digital Input 2 (TB1-2)(P194-2) (Pressure Switch S39)	Input energized by pressure switch setting.							
10	Occupied	A133 Digital Input 1 (TB18-1)(P194-1) (Pressure Switch S37)	A133 Digital Input 2 (TB1-2)(P194-2) (Pressure Switch S39)	Input energized by pressure switch setting.							
11	Blower is energized.	A133 Digital Input 1 (TB18-1)(P194-1) (Pressure Switch S37)	A133 Digital Input 2 (TB1-2)(P194-2) (Pressure Switch S39)	Input energized by pressure switch setting.							

Units equipped with an A133 board set for VAV operation and two-stage exhaust fans use the A56_P115-3 output to energize the exhaust relay for stage one when enabled. Stage two will not energize until 0 seconds default (ECTO 8.25) after stage one. Stage 1 will not de-energize until stage two has been de-energized for 100 Seconds (ECTO 8.22).
 VAV units with VFDs could use this option for two stage operation. In that case, the A56 P115-3 output is used to enable the VFD and the exhaust fan will operate at speed set with ECTO 8.17 (50% default) for stage 1 and ECTO 8.18 for stage 2.

Option	Enabled when	Input 1	Input 2	Setpoint 1		Deadband 1		Setpoint 2		Deadband 2	
				De-fault	ECTO	De-fault	ECTO	De-fault	ECTO	De-fault	ECTO
12	Always	A133 Analog Input 2 (TB18-7)(P194-7) (Pressure Sensor A34)	A133 Analog Input 2 (TB18-7)(P194-7) (Pressure Sensor A34)	-0.3 "w.c.	8.20	0.04 VDC	8.21	-0.42 "w.c. (1)	8.23	0.25" w.c.(1)	8.24
13	Occupied	A133 Analog Input 2 (TB18-7)(P194-7) (Pressure Sensor A34)	A133 Analog Input 2 (TB18-7)(P194-7) (Pressure Sensor A34)	-0.3 "w.c.	8.20	0.04 VDC	8.21	-0.42 "w.c. (1)	8.23	0.25" w.c.(1)	8.24
14	Blower is energized	A133 Analog Input 2 (TB18-7)(P194-7) (Pressure Sensor A34)	A133 Analog Input 2 (TB18-7)(P194-7) (Pressure Sensor A34)	-0.3 "w.c.	8.20	0.04 VDC	8.21	-0.42 "w.c. (1)	8.23	0.25" w.c.(1)	8.24
15	A133 Digital Input 1 (P194-1) is energized (Enable Switch)	A133 Analog Input 2 (TB18-7)(P194-7) (Pressure Sensor A34)	A133 Analog Input 2 (TB18-7)(P194-7) (Pressure Sensor A34)	-0.3 "w.c.	8.20	0.04 VDC	8.21	-0.42 "w.c. (1)	8.23	0.25" w.c.(1)	8.24

(1) Settings must be adjusted for proper operation.
 Units equipped with an A133 board set for VAV operation and two-stage exhaust fans use the exhaust fan relay for stage one when Digital Input 1 (P194-1) is energized and enabled. The A133_P194-5 output energizes the exhaust fan relay K201 for stage two when Digital Input 2 (P194-2) is energized and enabled. Stage two will not energize until 0 seconds default (ECTO 8.25) after stage one. Stage 1 will not de-energize until stage two has been de-energized for 100 Seconds (ECTO 8.22). This option typically would have two building pressure switches connected to the two Digital Inputs.
 VAV units with VFDs could use this option for two stage operation. In that case, the A56_P115-3 output is used to enable the VFD and the exhaust fan will operate at speed set with ECTO 8.17 (50% default) for stage 1 and ECTO 8.18 (100% default) for stage 2.

ECTO 8.16 EXHAUST CONTROL - Continued

VFD Exhaust With Low Speed Cycling								
Option	Enabled When	Input	Setpoint		Setpoint During Smoke Alarm		Minimum Speed	
			De-fault	ECTO	De-fault	ECTO	De-fault	ECTO
16	Always	A133 Analog Input 2 (TB18-7)(P194-7) (Pressure Sensor A34)	-0.30 "w.c.	8.20	-0.30 "w.c.	8.19	10% (1)	8.21
17	Occupied	A133 Analog Input 2 (TB18-7)(P194-7) (Pressure Sensor A34)	-0.30 "w.c.	8.20	-0.30 "w.c.	8.19	10% (1)	8.21
18	Blower is energized	A133 Analog Input 2 (TB18-7)(P194-7) (Pressure Sensor A34)	-0.30 "w.c.	8.20	-0.30 "w.c.	8.19	10% (1)	8.21
19	A133 Digital Input 1 (P194-1) is energized (Enable Switch)	A133 Analog Input 2 (TB18-7)(P194-7) (Pressure Sensor A34)	-0.30 "w.c.	8.20	-0.30 "w.c.	8.19	10% (1)	8.21

(1) Settings must be adjusted for proper operation. Units with exhaust VFDs use this option for variable speed exhaust operation. The A56_P115-3 output is used to enable the VFD. The VFD will vary the exhaust motor speed to maintain the static pressure setpoint (ECTO 8.20). ECTO 8.20 must be adjusted for this operation. If exhaust operates at minimum speed for a time period of 30 seconds, it will de-energize for a minimum time period of 30 seconds. Exhaust will energize when feedback exceeds the setpoint by 10%. This option typically would have a building pressure sensor connected to the Analog Input. The PID loop proportional (P) constant may be adjusted by ECTO 8.23, integral (I) constant may be adjusted by ECTO 8.24, derivative may be adjusted by E.CTO 8.25 and the reset value may be adjusted by ECTO 8.22.

VFD Exhaust								
Option	Enabled When	Input	Setpoint		Setpoint During Smoke Alarm		Minimum Speed	
			De-fault	ECTO	De-fault	ECTO	De-fault	ECTO
20	Always	A133 Analog Input 2 (TB18-7)(P194-7) (Pressure Sensor A34)	-0.30 "w.c.	8.20	-0.30 "w.c.	8.19	10% (1)	8.21
21	Occupied	A133 Analog Input 2 (TB18-7)(P194-7) (Pressure Sensor A34)	-0.30 "w.c.	8.20	-0.30 "w.c.	8.19	10% (1)	8.21
22	Blower is energized	A133 Analog Input 2 (TB18-7)(P194-7) (Pressure Sensor A34)	-0.30 "w.c.	8.20	-0.30 "w.c.	8.19	10% (1)	8.21
23	A133 Digital Input 1 (P194-1) is energized (Enable Switch)	A133 Analog Input 2 (TB18-7)(P194-7) (Pressure Sensor A34)	-0.30 "w.c.	8.20	-0.30 "w.c.	8.19	10% (1)	8.21

(1) Settings must be adjusted for proper operation. Units with exhaust VFDs use this option for variable speed exhaust operation. The A56_P115-3 output is used to enable the VFD. The VFD will vary the exhaust motor speed to maintain the static pressure setpoint (ECTO 8.20). ECTO 8.20 must be adjusted for this operation. Exhaust fan will not cycle off while enabled. This option typically would have a building pressure sensor connected to the Analog Input. The PID loop proportional (P) constant may be adjusted by ECTO 8.23, integral (I) constant may be adjusted by ECTO 8.24, derivative may be adjusted by ECTO 8.25 and the reset value may be adjusted by ECTO 8.22.

Unit Component Operation

COMPRESSOR PROTECTION AND DELAYS

Compressor Minimum Run Time (3 Phase Units Only)

Each compressor stage has a minimum run time of four minutes (ECTO 1.11, 4.13).

Compressor Off Delay (Single phase units only)

Compressors have a five minute (default) compressor off delay. (ECTO 1.10, 4.12).

Blower On Delay

On gas units, the blower is delayed 40 seconds (default) after the gas valve is energized. There is no blower delay on cooling and heat pump units (ECTO 1.02, 2.02, 3.02, 4.02).

Freezestats (S49, S50, S53, S59)

Normally closed freezestats open when evaporator coil temperature drops to de-energize the corresponding compressor. Once coil temperature rises the switch automatically resets to allow compressor operation. The corresponding compressor is locked out after three occurrences. (ECTO 4.04).

High Pressure Switches (S4, S7, S28, S96)

High pressure switches open on a pressure rise to de-energize the corresponding compressor for five minutes (ECTO 5.02). Switches automatically reset when pressure drops. The corresponding compressor is locked out after three occurrences. (ECTO 4.14).

BURNER PROTECTION AND DELAYS

Burner Control - Gas Units

Primary or Secondary Limits (S10, S21, S99, S100, S130, S131)

If primary or secondary limits open during heating, the IMC will de-energize the gas valve and energize the blower.

If primary or secondary limits open three times (default) during a thermostat cycle, the service alarm output will turn on.

Roll-Out Switch (S47, S69)

If roll-out switch opens, the gas valve will be de-energized and a manual reset is required to restart.

Combustion Air Switch (S18, S45)

If the combustion air switch opens during heating the gas valve is de-energized. If the combustion air switch opens 3 (default) times, the service alarm output will turn on.

Gas Valve Sense

If the gas valve is not energized 2 minutes after a heating demand, the M1-7 will display and store error code 58 for gas valve 1 and 68 for gas valve 2.

If the gas valve is energized and de-energized 3 (default) times during a single heating demand, the M1-7 will display and store error code 59 for gas valve 1 and 69 for gas valve 2. The service relay will be activated.

The IMC will also de-energize all outputs and turn on the service output if the gas valve is energized without a heating demand.

Gas Valve Delays

The IMC has a 30 second (default) delay between first and second stages. A timed off delay (100 seconds default) will prevent gas heat operation until 100 seconds has passed from the previous cycle. (ECTO 3.05, 3.06).

MISCELLANEOUS COMPONENTS

Unoccupied Or Night Setback Mode

During the unoccupied time period dampers do not operate at minimum position (no minimum ventilation requirements during unoccupied period).

Local Thermostat Mode

The unoccupied time period occurs when there is no input at A55 (M1-7) board P110-2 or unit TB1 terminal 9.

Zone Sensor Mode

The occupied time period is controlled by the optional NCP when installed. The TB1-9 input is ignored while in the zone sensor mode except during back-up operation.

Gas and Electric Heat Warm-Up Mode (During occupied time period)

Many building codes require a percentage of fresh outdoor air when a conditioned space is occupied. A 24 vac input at unit TB1 terminal 9 (A55 or M1-7 board P110-2) energizes the "occupied" (usually daytime) time period. A field-provided and -installed thermostat or energy management system provides the input.

The first 60 minutes (default) of the **first** heating demand of the occupied time period is called the "warm-up mode".

During the warm-up mode the IMC keeps economizer dampers closed to conserve energy. (ECTO 2.01, 3.01).

The warm-up mode may be bypassed by pressing the pushbutton a short push.

Heat Pump Warm-Up Mode

The default IMC setting allows supplemental heat to be used during warm-up mode. Supplemental heat may be locked out during warm-up mode for energy savings in two different ways. See the Electronic Configure to Order Control Parameters section to lock out supplemental heat during warm-up. ECTO 1.01, 1.17.

Cool-Down Mode (During occupied time period)

To conserve energy, the IMC ignores second-stage cooling demand and the economizer opens the first 30 minutes (default) **OR** one cooling cycle (whichever happens first) when the occupied time period starts. The cool-down mode applies only when outdoor air is suitable for free cooling. ECTO 4.01.

The cool-down mode may be bypassed by pressing the pushbutton a short push.

Air Flow Switch (S52-Optional)

The air flow switch closes during normal unit operation. If air flow is interrupted 16 seconds after blower demand, S52 opens and the IMC de-energizes the compressor, gas valves, electric heat, and closes economizer damper. The service alarm output will turn on.

Dirty Filter Switch (S27-Optional)

The dirty filter switch is open during normal unit operation. A dirty filter will close S27 and the M1-7 will display and store the error code and turn on the service alarm output.

GAS HEAT OPERATION-GAS UNITS

The IMC has gas heat output control for up to two gas heat burners with two-stage gas valves. A first-stage heat demand energizes the gas valve low fire and a second-stage heat demand energizes the high fire. On units that have two heat sections, a first-stage heat demand energizes low fire on both gas valves and a second-stage heat demand energizes high fire on both gas valves.

ELECTRIC HEAT OPERATION- ELECTRIC / ELECTRIC UNITS

Electric Heat Operation

First-stage heating demand energizes first-stage electric heat (K15 and K17). Second-stage heating demand energizes second-stage electric heat (K16 and K18). When first-stage and second-stage heating demands are simultaneous, a 12-second delay will occur between stage one and stage two (ECTO 2.05).

Primary or Secondary Limits

If an electric heat limit (S15 or S63) opens, electric heat is de-energized.

If an electric heat limit opens three times during a thermostat cycle, the service alarm output will turn on (ECTO 2.04).

HEAT PUMP OPERATION

Heat Operation

First-stage heating demand energizes compressor(s) for first-stage heating. Second-stage heating demand energizes supplemental electric heat via K15, K16, K17, and K18 electric heat contactors. K15 and K17 are

energized immediately; K16 and K18 are energized after a 12-second delay (ECTO 1.05).

Primary or Secondary Limits

If an electric heat limit (S15 or S63) opens, electric heat is de-energized.

If an electric heat limit opens five times during a thermostat cycle, the service alarm output will turn on (ECTO 1.04).

Defrost Cycle

Defrost is initiated when the defrost temperature switch (S6 or S9) closes. Defrost terminates either when defrost pressure switch (S46 or S104) opens or when 15 minutes (default) has elapsed. (ECTO 1.16). The defrost cycle is **not** terminated when a thermostat demand ends. Only one defrost cycle is allowed for every 60 minutes (default) of run time. (ECTO 1.15).

The first stage of supplemental electric heat is energized when defrost is initiated (default). In units with multiple refrigerant circuits, supplemental electric heat is energized with each defrost circuit. (ECTO 1.14).

NOTE - If ECTO 1.14 is set to "0", there will be no supplemental heat during defrost.

Economizer dampers close during a defrost cycle.

Defrost Test

Unit must be operating in heating mode to initiate a defrost test.

Initiate defrost:

- 1- Turn RECALL and UNIT TEST DIP switches to "ON". The software version will be displayed.
- 2- Hold pushbutton down for five seconds (long push).

NOTE - Only stages currently operating in heating are tested. If both stages are operating in heating, both stages of defrost are tested and the defrost times for both stages are synchronized.

- 3- Defrost will terminate automatically when defrost pressure switch (S46 or S104) opens.

Terminate defrost manually:

- 1- Press the pushbutton (short push).

Re-run a defrost test:

- 1- Press the pushbutton (short push) to by-pass delays.
- 2- Hold pushbutton down for five seconds (long push).

Defrost Readout

The readout will display "DF1" when the first stage is operating in defrost mode, "DF2" will display when the second stage is operating in defrost mode, and "DF-" will display when both stages are operating in defrost mode. The readout does not function during the defrost test.

Supplemental Heat Lock Out

The IMC will not allow the delayed (K16 and K18) bank of electric heat to be energized if the outdoor temperature is above 30°F default (ECTO1.06).

The IMC will not allow any banks of electric heat to energize when outdoor air temperature is above 40°F default (ECTO 1.07).

Test Supplemental Electric Heat Operation

To test the operation of supplemental electric heat at outdoor temperatures above 40°F (default), turn on W2 input only (emergency heat). See “Testing Unit Function” section. Supplemental electric heat will be energized. To test supplemental heat with compressor operating, disconnect outdoor air temperature sensor RT17.

Thermostats With Emergency Heat Function

When ONLY the W2 thermostat input is energized, the IMC will lock-out compressor operation and energize only electric heat. Electric heat temperature lock-outs are also ignored.

LOW PRESSURE SWITCHES(S87, S88, S98, S97)

Low pressure switches may trip during lower outdoor temperatures, especially with longer time periods between compressor cycling. Each compressor stage has the strike three control feature. The strike three control has three functions:

- 1- De-energizes the compressor for five minutes (default) if the low pressure switch trips (once the ignore time period is elapsed).
- 2- Ignores the low pressure switch for a specified period of time after thermostat demand.
- 3- Locks out the compressor stage if the low pressure switch trips three times within the same thermostat demand (once the ignore time period is elapsed).

Low Pressure Switch Off

Once the ignore time period has passed, the low pressure switch will de-energize the compressor. The IMC control will prevent compressor operation for five minutes. See ECTO parameter 5.02 to change compressor off time interval.

Note - Low pressure switches are ignored on heat pump units during heating.

Ignore Or Shunt Time Period

The specified time period varies according to compressor off time and the outdoor ambient temperature. See chart 1 for default times and temperatures and the electronic configure to order (ECTO) parameter used to adjust the ignore time period.

Control De-Energizes Unit

If the low pressure switch trips three times (default) during a thermostat demand, the IMC will lock out the compressor. The number of times required to de-energize the unit is adjustable. (ECTO 1.13, 4.15).

**CHART 1
LOW PRESSURE IGNORE DEFAULT TIME PERIOD**

		Compressor Off Time ECTO 5.14	
		Short < 4 Hrs.	Long > or = 4 Hrs.
Ambient Temperature ECTO 5.15	Cold < 70 Deg. F	5 Minutes ECTO 5.13	12 Minutes ECTO 5.11
	Hot > or = 70 Deg. F	2 Minutes ECTO 5.12	6 Minutes ECTO 5.10

LOSS OF POWER DETECTION (Single phase units only)

The IMC will turn off compressors for five minutes (default) if a loss of power is detected for two cycles. This indicates a problem with supply voltage; waiting five minutes allows pressures to equalize ensuring start-up. (ECTO 5.02).

THERMOSTAT BOUNCE DELAY (Local thermostat mode only)

The IMC will ignore room thermostat inputs for three seconds to prevent sporadic cycling.

RETURN AIR TEMPERATURE LIMITS

Zone temperatures may be limited by changing ECTO parameter 5.05. Change ECTO 5.06 to interrupt a heating demand and ECTO 5.07 to interrupt a cooling demand. If return air temperatures are exceeded, the demand will be interrupted. Error codes 40 or 41 are displayed but not stored in memory for recall.

Smoke Detector (A17-Optional)

If smoke detector senses smoke, normally opened contacts close. The IMC turns off the unit and closes the economizer dampers. Variations in damper position and power exhaust and blower operation may be changed (ECTO 5.01). See table 29.

Safety Switch Input (A42-Optional)

The IMC has a 24 volt optional input (P110-9) which may be used for additional safety switches (such as a blower overload, loss of phase protector, or supply duct high pressure limit switch). Wire the safety switch in series with the input. When the input is de-energized, the IMC will turn off all outputs and display error code #20 (ECTO 5.08). For normal operation, the input must be energized with 24VAC.

**TABLE 29
SMOKE ALARM OPERATION**

ECTO 5.01	Operation				
	Blower	Exhaust. Fan		Fresh Air Damper	Description
		Single/Two Stage (2)	VFD		
0	Off	Off	Off	Closed	Unit Off
1	On (1)	Off	Off	Open	Positive Pressure
2	On (1)	On	Speed = ECTO 8.19	Closed	Negative Pressure w/ Blower Exhaust fan at fixed speed
3	On (1)	On	Speed = ECTO 8.19	Open	Purge Exhaust fan at fixed speed
4	Off	On	Speed = ECTO 8.19	Closed	Negative Pressure Exhaust fan at fixed speed
5	On (1)	On	Building Static SP=ECTO 8.19	Closed	Negative Pressure w/ Blower Exhaust fan at fixed speed
6	On (1)	On	Building Static SP=ECTO 8.19	Open	Purge Exhaust fan modulates
7	Off	On	Building Static SP=ECTO 8.19	Closed	Negative Pressure Exhaust fan modulates

(1)-Blower with VFDs operation depends on ECTO 0.01 settings. If set to PID, supply static SP = ECTO 0.02, if set to staged, blower speed = ECTO 0.02. For CAV units with bypass dampers, supply static SP= ECTO 0.13.
(2)-Both exhaust fan stages will operate on units with two stage fans.

Low Ambient Fan Cycling

During low ambient conditions, various outdoor fans are cycled by liquid line pressure switches S11, S84, S85, and S94. The IMC will de-energize fans due to temperature and/or time delays. Determine fan cycling and compressor operation for each unit in figures 31 and 32.



Note - Low ambient pressure switches are by-passed in the heating mode on heat pump units.

Compressors are de-energized by the IMC below 0°F/-18°C (default). See ECTO 4.08, 4.09, 4.10, and 4.11 to adjust the cut-out temperature.

Multiple low ambient switches on the same fan must ALL be open to de-energize fan.

The M1-7 readout will display "LAL" when one or more compressors are locked out in a low ambient condition.

KEY

Symbol	Description
	Fan energized when liquid pressure is higher than 275 psig R-22 / 450 psig R410A De-energized when liquid line pressure less than 150 psig R-22 / 240 psig R410A. <i>Note - A box units fans are de-energized at 140 psig.</i>
55°F	IMC (TP2) De-energizes fan below 55°F/13°C (default ECTO 4.07)
40°F	IMC (TP1) De-energizes fan below 40°F/4.4°C (default ECTO 4.06)
	IMC board delays the fan 2 second (default 4.16) after thermostat demand.

COMPRESSOR AND FAN OPERATION (TOP VIEW OF UNIT NOT TO SCALE)

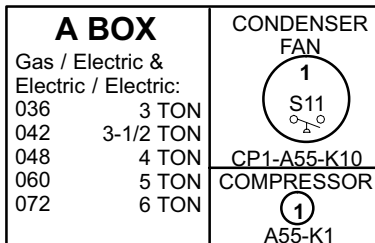

CP1 Compressor 1
CP2 Compressor 2
CP3 Compressor 3
CP4 Compressor 4

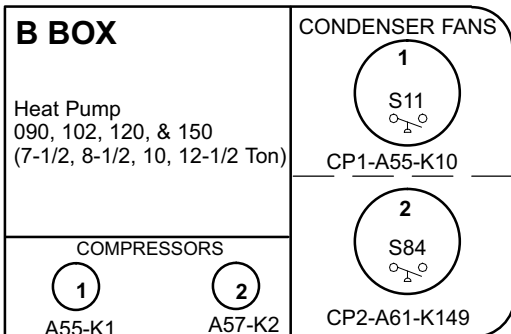
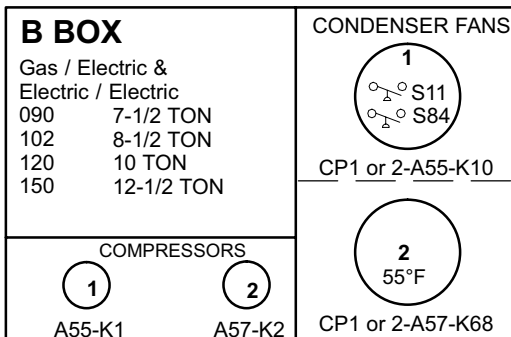
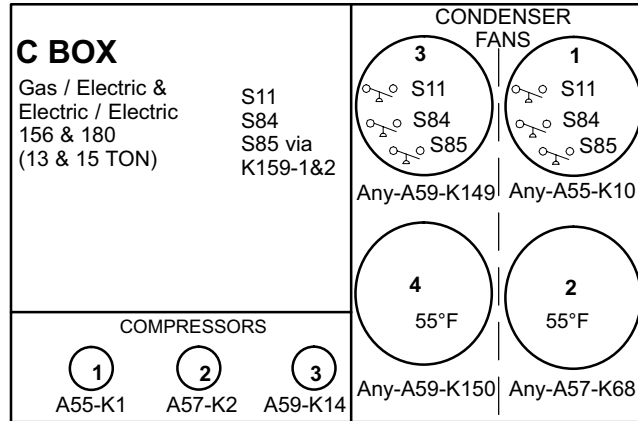

D BOX

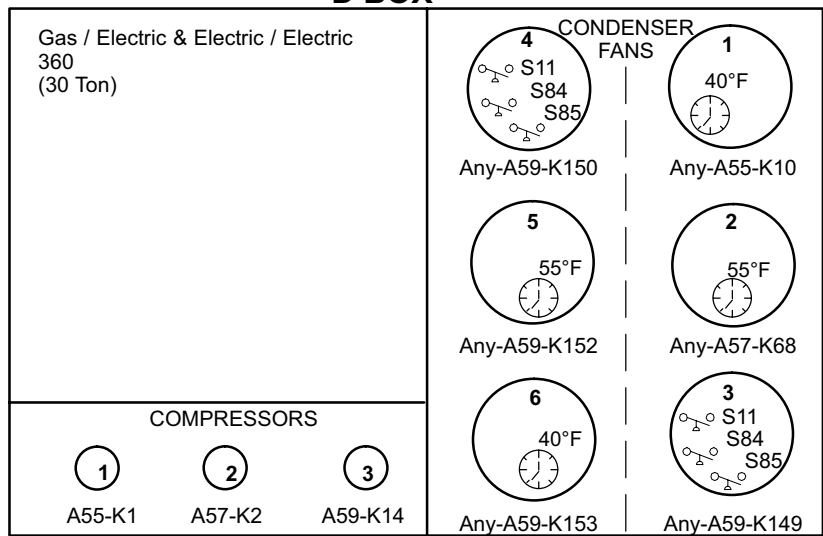

FIGURE 31

COMPRESSOR AND FAN OPERATION (TOP VIEW OF UNIT NOT TO SCALE)

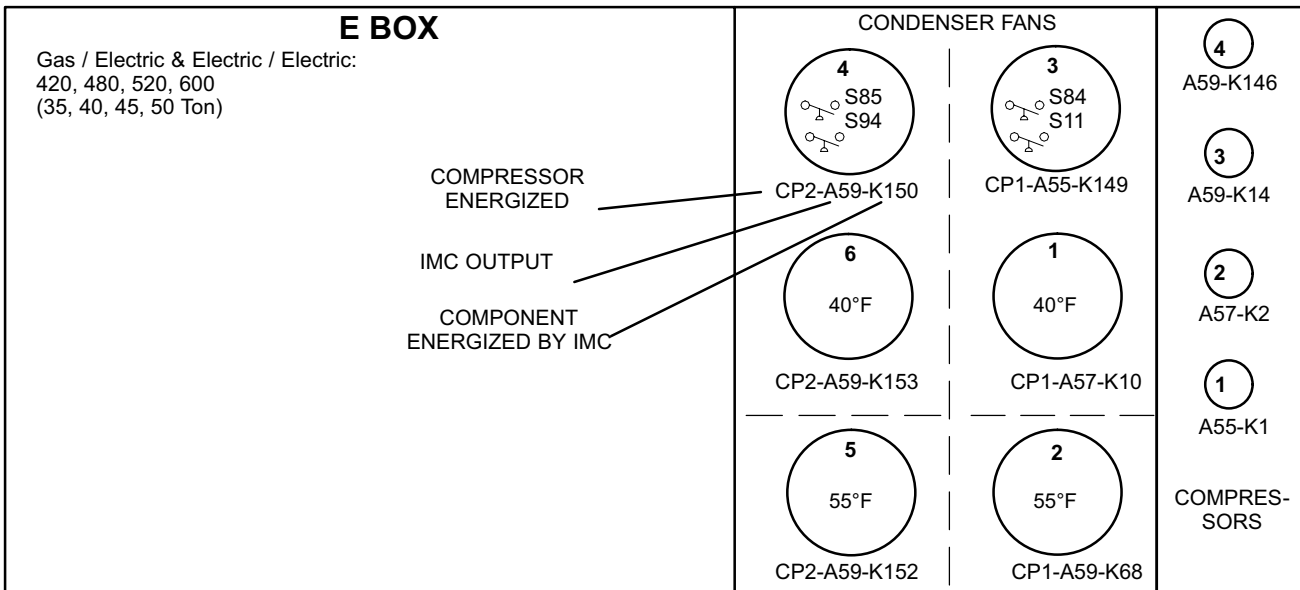
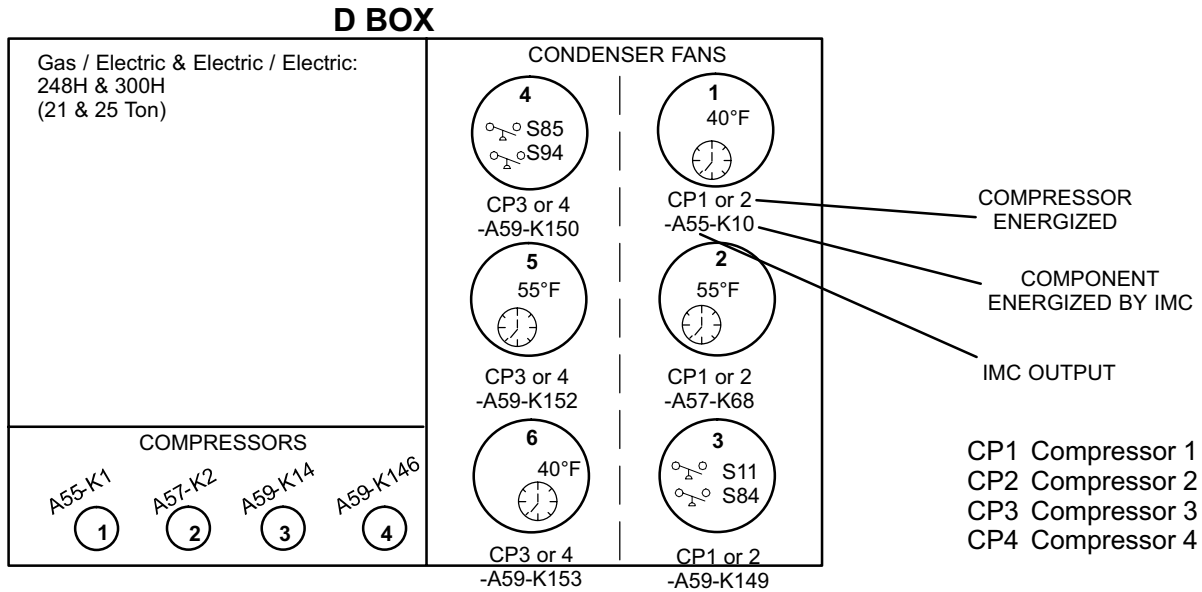
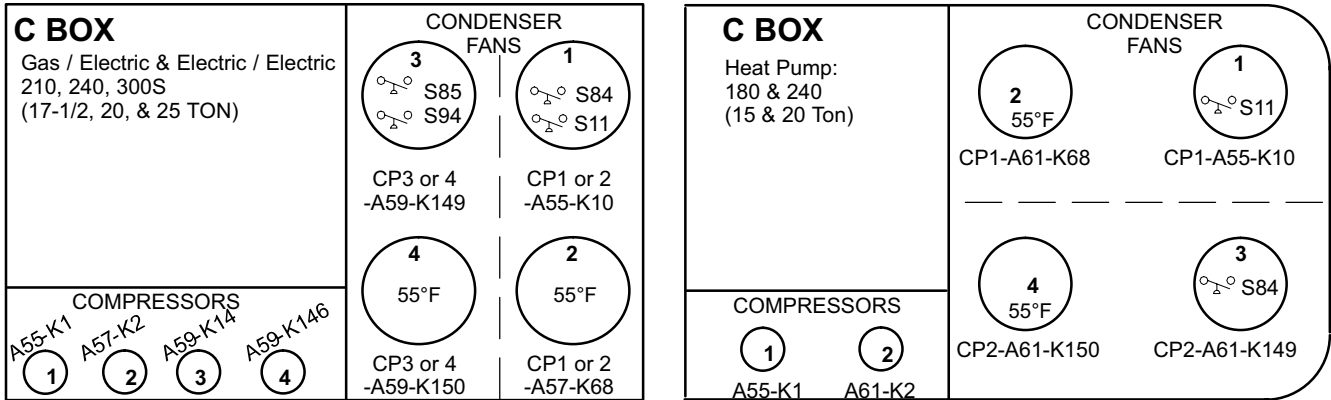

FIGURE 32

Optional Economizer

GENERAL

The A56 (EM1) economizer board controls economizer damper position. Damper position determines how much outdoor air is used for free cooling or for indoor air quality (IAQ) requirements. The A56 also controls the optional power exhaust fans.

On a cooling demand, outdoor air is used for free cooling instead of first-stage compressor(s) when outdoor air is suitable.

HEARTBEAT LED

Flashing green LED indicates normal operation. See figure 33.

OUTDOOR AIR SUITABLE LED

A steady yellow LED indicates that outdoor air is suitable for free cooling. A flashing yellow OAS light indicates the IAQ sensor requires outdoor air. If the economizer is already operating, a flashing yellow OAS light indicates the IAQ sensor requires more outdoor air than is suitable for free cooling.

On the A56 (EM1) software version 1.00, OAS LED is not used in global enthalpy mode. On software version 1.01 and higher, OAS LED is on if the global input is on.

DIP SWITCH SETTINGS

The A56 EM1 DIP switch setting determines the mode used to enable free cooling. The DIP switch also has a

mode to set the damper minimum position and test damper operation. DIP switch is factory-set when the economizer is factory-installed.

FREE COOLING DISCHARGE AIR SETPOINT

When outdoor air conditions are suitable and economizer is operating in free cooling, dampers will modulate to achieve a discharge air temperature of 55°F (13°C) default. This setpoint can be adjusted between 45° and 65°F as required for the application. ECTO 6.23.

The setpoint can also be automatically increased when outdoor or return air temperatures drop. See Outdoor Air Reset and Return Air Reset in the Discharge Air Control section. The unit does not have to be operating in discharge air cooling mode to adjust the setpoint.

OUTDOOR AIR SUITABILITY

There are six options available to determine outdoor air suitability (OAS) for free cooling. See table 30. A56 EM1 economizer board settings are shown for each mode in figure 34.

The setpoint can also be adjusted using ECTO 8.01-8.07.

The appropriate sensors are provided when the economizer is factory-installed. When the economizer is field-installed, the ODE mode requires additional field-provided sensor(s). See table 30. The TMP mode uses sensors provided with all units.

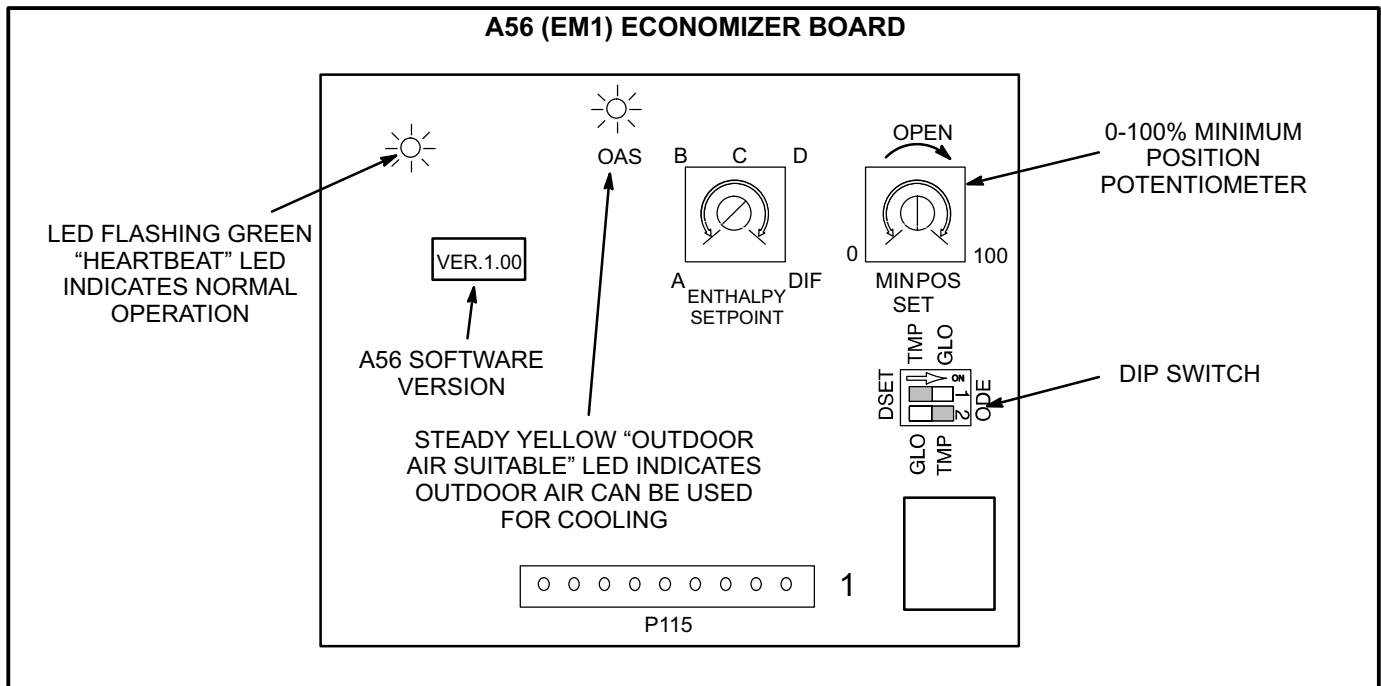

FIGURE 33

**TABLE 30
FREE COOLING OPTIONS**

Mode	Outdoor Air Is Suitable For Free Cooling When:
TMP Differential	Outdoor air temperature (RT17) is less than return air temperature. (RT16). Enthalpy setpoint is ignored.
TMP Offset	Outdoor air temperature (RT17) is less than return air temperature (RT16) by at least ECTO 6.26 (0-40°F). Enthalpy setpoint is ignored.
TMP	Outdoor air temperature (RT17) is less than ECTO 6.26 (35-70°F). Enthalpy setpoint is ignored.
ODE Differential	Outdoor air enthalpy* (A7) is less than return air enthalpy (A62).
ODE	Outdoor air enthalpy (A7) is less than enthalpy setpoint potentiometer position A, B, C, or D.
GLO	Global input is energized by (TB1-1). This setting is also used for outdoor air damper applications. Global input also brings on the blower.

*Temperature + humidity= enthalpy.

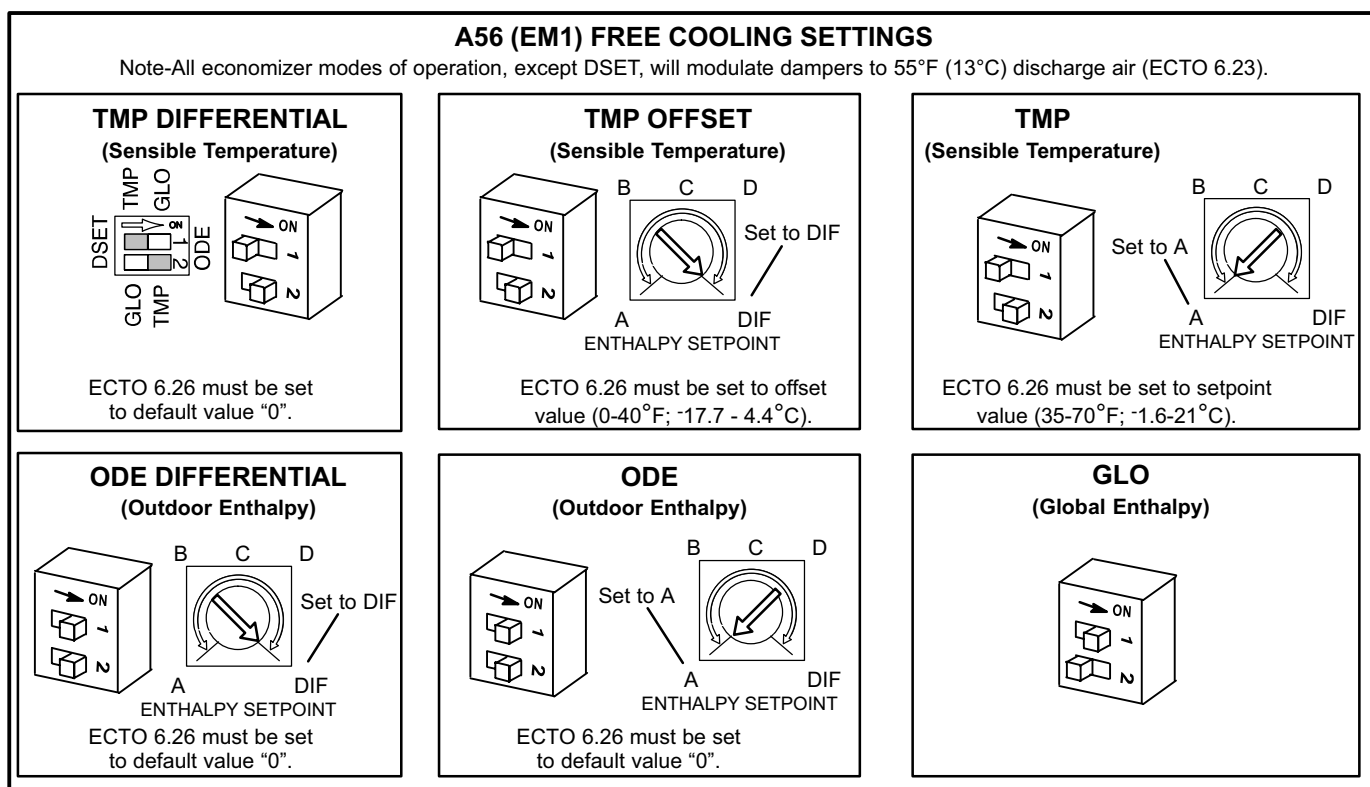

FIGURE 34

ENTHALPY SETPOINT

This setting pertains to the ODE free cooling mode only.

The IMC will enable free cooling when outdoor air enthalpy (A7) is less than the A56 EM1 enthalpy setpoint. Table 31 shows the approximate enthalpy setpoints for each potentiometer setting at 50% relative humidity.

The recommended enthalpy setpoint is "A". If the economizer is allowing air which is too warm or too humid to enter the system, the enthalpy control may be changed to a lower setting (B, C, or D).

**TABLE 31
ENTHALPY CONTROL SETPOINTS**

Control Setting	Enthalpy Control Setpoint At 50% Relative Humidity Approximate Degrees F (C)
A	73 (23)
B	70 (21)
C	67 (19)
D	63 (17)

ECONOMIZER

Example:

At setting “A”, the enthalpy control will modulate dampers open when outdoor air is at 73°F and 50% relative humidity. If space temperatures are too warm, rotate the potentiometer to “B”. The enthalpy control will now modulate dampers open when outdoor air is 70°F and 50% relative humidity.

DAMPER MINIMUM POSITION POTENTIOMETER

Set economizer DIP switch to “DSET” position as shown in figure 35. DSET is a manual mode that locks the economizer into minimum position.

Rotate MIN POS SET potentiometer to approximate desired damper position.

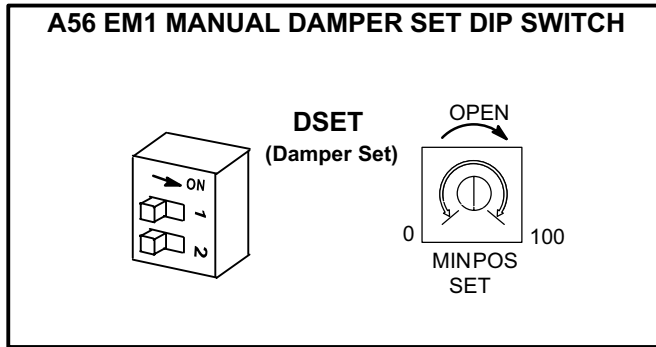

FIGURE 35

Check indicator on damper motor to determine actual damper position. Adjust potentiometer until damper motor reads desired position. See figure 36.

Damper minimum position can also be set using ECTO 5.24. This will disable the potentiometer.

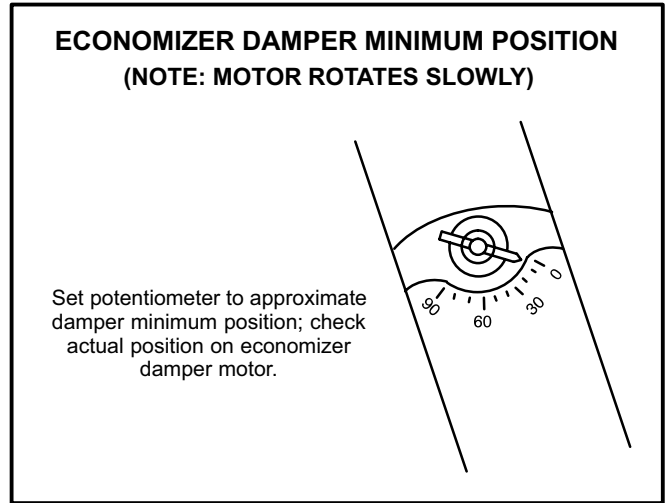

FIGURE 36

DAMPER MAXIMUM POSITION

Economizer dampers open to 100% at the default setting. Adjust ECTO parameter 5.23 to reduce the maximum damper opening for free cooling.

MOTORIZED OUTDOOR AIR DAMPER

Set damper position according to “Damper Minimum Position Potentiometer” section. For normal operation, make sure the economizer board DIP switch is set to “GLO” position as shown in figure 34. The damper will open to the specified position during the occupied time period and close during the unoccupied time period.

ECONOMIZER CHECKOUT

The following checkout procedures are completed with unit energized. Confirm proper operation of the heartbeat LED on the A56 (EM1) economizer control board. See "IMC Board Components" section.

Step 1 will determine whether the A56 EM1 is allowing full damper travel. Use step 2 when the damper does not respond to step 1.

Steps 3, 4, 5, and 6 checkout the operating modes; checkout only the mode that applies to the unit being worked on. Use "DSET" Operation checkout only when step 1 refers to it.

CAUTION-Power exhaust fans will be functional. To prevent operation of gravity exhaust fans, disconnect power to unit and then PED jack/plug P/J18.

STEP 1

A56 ECONOMIZER BOARD OUTPUT VOLTAGE

- 1- Set the A56 DIP switch to DSET.
- 2- Adjust the MIN POS SET potentiometer (on A56 board) to the 0% position (fully counterclockwise). The motor will slowly modulate to the closed position.
- 3- Adjust the MIN POS SET potentiometer to the 100% position (fully clockwise). The motor will slowly modulate to the fully opened position.
- 4- If the motor does not respond, go to step 2. If the motor does respond properly, go to the appropriate mode of operation checkout.

STEP 2

"DSET" OPERATION

- 1- Disconnect J115 from P115 on A56 EM1 board.
 - 2- Set the DIP switch to the "DSET" position.
 - 3- Adjust the MIN POS SET potentiometer to the 0% position (fully counterclockwise).
 - 4- Measure the voltage on P115 between pin 2 (VOT) and pin 1 (TB34-2) **using pin 1 as common**. Voltage should read approximately 2 volts DC on EM1 (A56) software version 1.02 and higher; voltage should read approximately zero on EM1 (A56) software version 1.00 and 1.01.
 - 5- Adjust the MIN POS SET potentiometer to the 100% position (fully clockwise).
- NOTE - Allow approximately 30 seconds for voltage to react.*
- 6- Measure the voltage between P115 pin 2 and 1 **with pin 1 as common**. Voltage should read approximately 10 volts DC.

Connect J115 to P115 and measure the same terminals again. This confirms that output voltage is correct at the board and the connector.

If the voltage changes more than .5VDC, there may be a wiring or motor problem.

If voltage at P115 pin 2 and 1 remains 10 volts, check continuity in wiring between the control board and the damper motor.

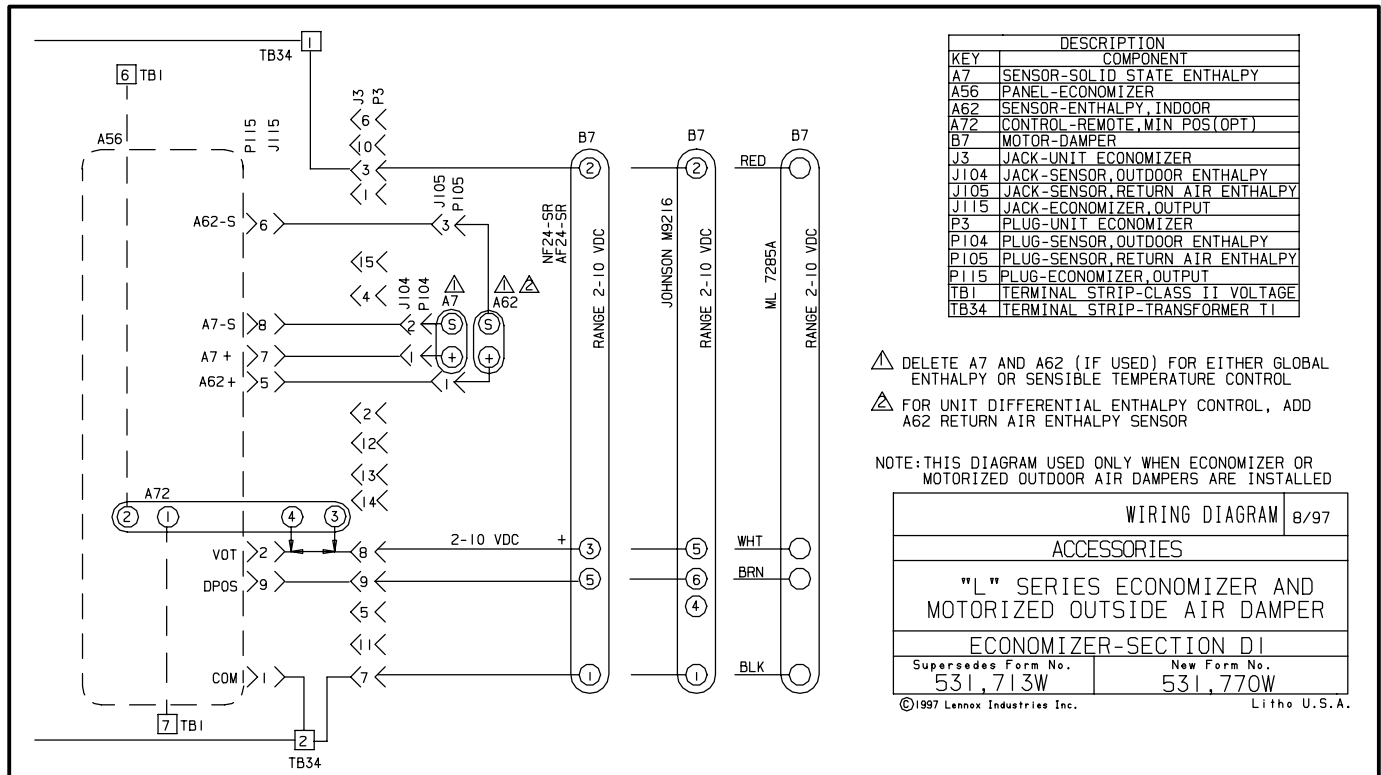

ECONOMIZER

**STEP 3
“ODE” MODE OF OPERATION**

In the ODE mode, dampers open for free cooling when the outdoor enthalpy is less than the enthalpy setpoint; dampers will modulate discharge air temperature (RT6) to 55°F (13°C).

- 1- Set the A56 DIP switch to ODE mode.
- 2- To simulate low outdoor enthalpy, set the enthalpy setpoint to “B.” Disconnect A7 outdoor enthalpy sensor jack/plugs J/P104. Connect a 200 ohm resistor across plug J104-1 and J104-2. J104 is located in the filter access area.
- 3- After a few seconds delay, the yellow OAS LED on the A56 board should turn on.
- 4- If the OAS LED does not turn on, check all connections and wiring between J104 and the control.

**STEP 4
“ODE DIFFERENTIAL” MODE OF OPERATION**

In the DIF mode, dampers open for free cooling when the outdoor air enthalpy is lower than the return air enthalpy; dampers will modulate discharge air temperature (RT6) to 55°F (13°C).

- 1- Set the A56 DIP switch to ODE.
- 2- Set the enthalpy setpoint potentiometer to DIF.
- 3- Use two resistors to simulate outdoor air enthalpy suitable.
 - a)-Disconnect J/P105 A62 return air enthalpy sensor jack/plug. Place a 750 ohm resistor between J105-1 and J105-3. J/P105 is located in the filter access area.
 - b)-Disconnect A7 outdoor enthalpy sensor jack/plugs J/P104. Connect a 100 ohm resistor across J104-1 and J104-2.
- 4- After a few seconds delay, the yellow OAS LED will turn on.
- 5- If the OAS LED does not turn on, check all connections and wiring between J104 and A56, and between J105 and A56.

**STEP 5
ALL “TMP” MODES OF OPERATION**

In the TMP modes, the damper opens for free cooling when the outdoor air temperature is:

- Less than return air temperature (TMP DIFFERENTIAL)
- ECTO 6.26 less than return air temperature (TMP OFFSET)
- Less than ECTO 6.26 (TMP)

In all modes, dampers will modulate discharge air temperature (RT6) to 55°F (13°C).

Refer to the “Displaying Sensor Inputs” section to read return air (RT16) and outdoor air (RT17) temperatures. If outdoor air is not cooler than return air, simulate a colder outdoor air temperature with a resistor. Select a resistor value that corresponds to a temperature:

- Less than return air temperature (TMP DIFFERENTIAL)
- ECTO 6.26 less than return air temperature (TMP OFFSET)
- Less than ECTO 6.26 (TMP)

See table 32.

TABLE 32

TEMPERATURE °F (°C)	SIZE RESISTOR
30 (-1)	34,566
40 (4)	26,106
50 (10)	19,904
60 (16)	15,313
70 (21)	11,884
80 (27)	9,298
90 (32)	7,332
100 (38)	5,826

- 1- RT17 is located on the right wall of the control/compressor section on non-heat pump units. RT17 is located on the right front corner mullion of heat pump units. Disconnect 1/4” quick connect terminals on wires leading from sensor.
- 2- Jumper RT17 wires leading back to control with the appropriate resistor.
- 2- After a few seconds delay, the yellow OAS LED on the A56 board should turn on.
- 3- If the OAS LED does not turn on, check all connections and wiring between RT17 and the A55 main control board, and RT16 and the main control board.

**STEP 6
GLO MODULATING MODE OF OPERATION**

In the GLO (modulating) mode, dampers modulate open for free cooling when the global input is energized; dampers will modulate discharge air temperature (RT6) to 55°F (13°C).

NOTE - The global input turns on the blower.

- 1- Set the A56 DIP switch to GLO.
- 2- Connect a jumper between TB1-6 (24vac) and TB1-1 (global). The blower will be energized and the damper will slowly open if discharge air temperature (RT6) is greater than 55°F (13°C).

NOTE - On A56 software version 1.00, OAS LED is not used in global enthalpy mode. On A56 software versions 1.01 and higher, OAS LED is on if the global input is on.

- 3- Disconnect 24vac to TB1-1. The blower will turn off and the damper will close.
- 4- If the damper does not actuate check all connections and wiring between J115 and J3.

STEP 7

ENTHALPY SENSOR OPERATION (A7 AND A62)

- 1- Connect a DC ammeter as shown in figures 37 and/or 38.

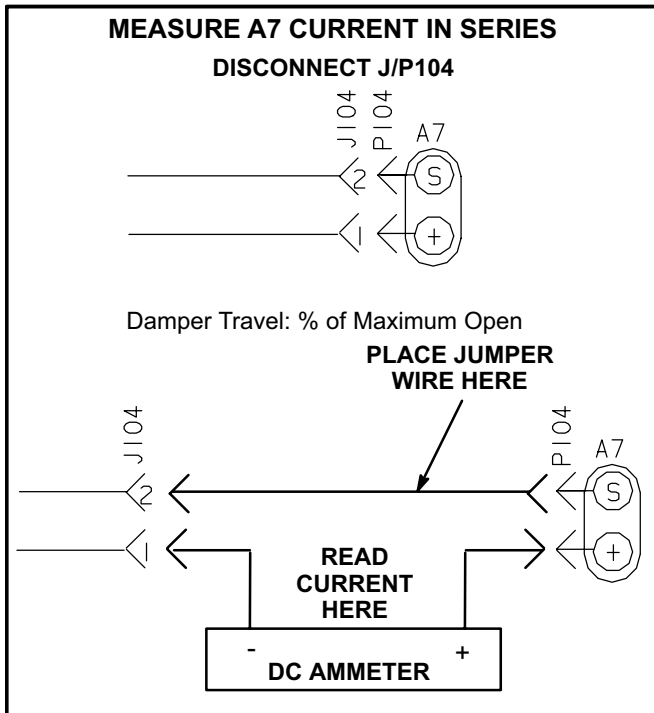

FIGURE 37

- 2- The reading will be between 4 and 20 ma. depending on outdoor temperature and humidity. Refer to table 33 to approximate reading.
- 3- If the meter reads zero, check sensor wiring harness for continuity and/or check polarity of sensor wiring.

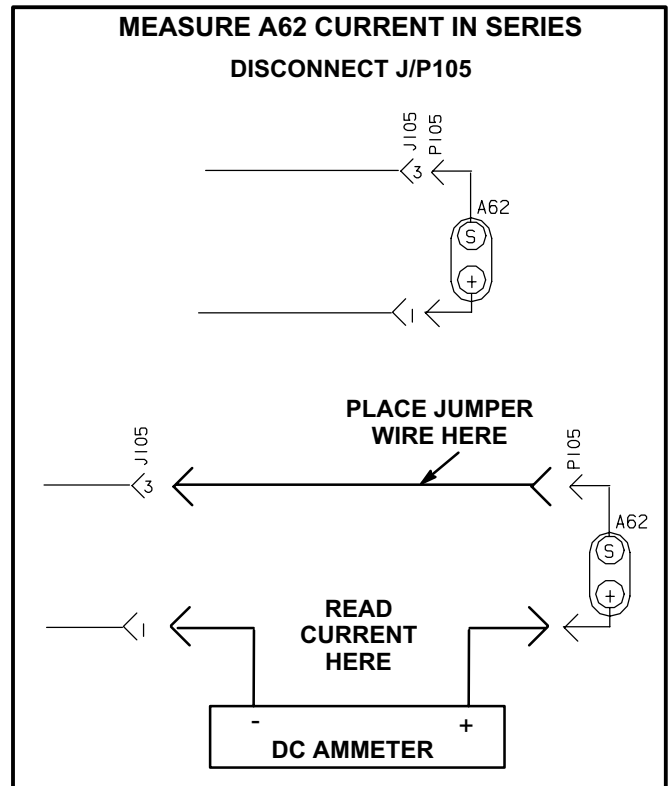
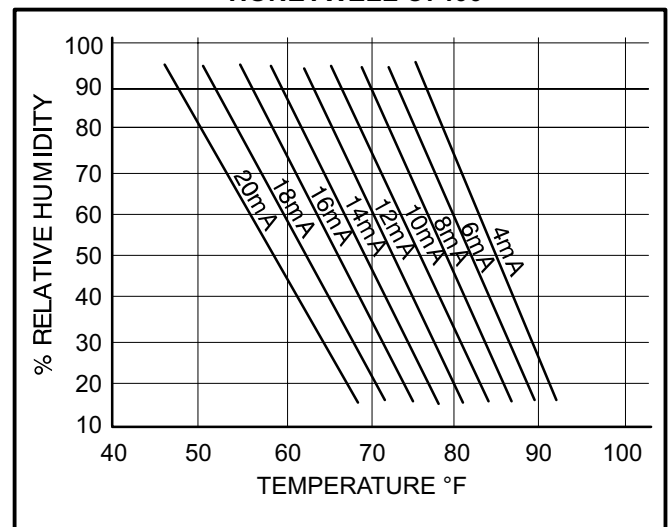

FIGURE 38

**TABLE 33
ENTHALPY SENSOR OUTPUT CURRENT
HONEYWELL C7400**



ECONOMIZER

DEMAND CONTROL VENTILATION

General

A field-provided and installed indoor air quality sensor can be used with the modulating economizer to control CO₂ levels in the conditioned space. The CO₂ level in a space is an indicator of the number of people occupying a room. As the CO₂ level rises (indicating the occupancy of a room has increased), economizer dampers modulate open - regardless of outdoor air enthalpy. Likewise, as the CO₂ level falls (indicating the occupancy has decreased), economizer dampers modulate further closed.

Standard economizer installations have a minimum fresh air ventilation requirement based on maximum room occupancy. With standard economizer use, the amount of air required for maximum room occupancy is heated or cooled with each heating or cooling cycle. IAQ economizer installations use the maximum amount of required ventilation air only with maximum room occupancy; less outdoor air needs to be heated or cooled when fewer people are in the conditioned space.

If the economizer is operating in the free cooling mode and the IAQ control requires the damper to open further, the IAQ demand will override the free cooling demand. A flashing OAS LED on the A56, EM1 economizer board indicates an IAQ override condition.

The IAQ function is not energized during the unoccupied or night time period.

NOTE - The IAQ sensor may also be used with systems containing a motorized outdoor air damper.

Default Operation

The IMC has a 0-10VDC IAQ input for a standard 0-2000ppm CO₂ sensor. The economizer starts opening at a CO₂ level of 500 ppm ("start open" setpoint) and reaches full open at a CO₂ level of 1000ppm ("full open" setpoint). The damper opens to 100%. Determine damper travel position using the following formula. Use "Displaying Sensor Inputs" section to read CO₂ ppm. Figure 39 shows default or proportional operation.

$$\% \text{ Damper Travel} = \frac{\text{CO}_2\text{ppm} - \text{Start Open ppm}}{5}$$

For example: at a CO₂ level of 750ppm, the damper will be approximately 50% open.

$$\% \text{ Damper Travel} = \frac{750 - 500}{5} = 50\%$$

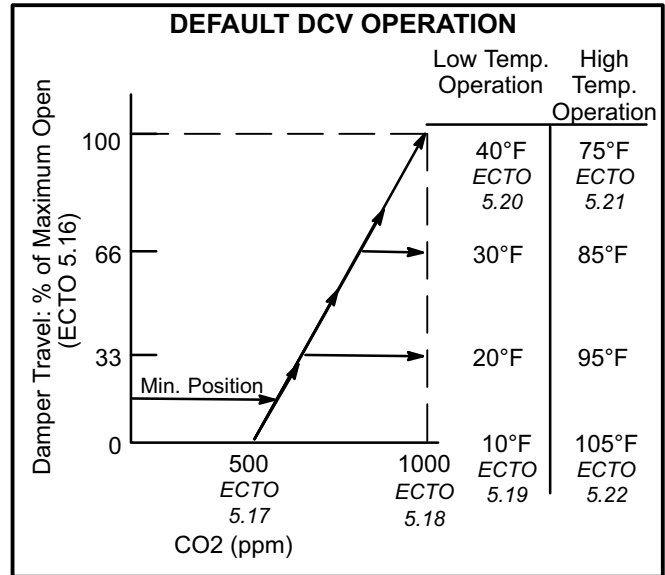

FIGURE 39

ECTO Adjustments

Default IAQ economizer operation is based on common or average applications. Adjustments may be made to the IAQ ECTO parameters to alter operation or meet required specifications. Use the "ECTO Control Parameters" section to change ECTO parameters 5.16 through 5.22.

The IMC uses M1 board A55-P114-12 (TB1-15) input or the network IAQ to enable DCV. Adjust ECTO 5.26 to change the input and mode to one of the following options.

- 1- DCV System IAQ. Either A55_P114-12 (TB1-15) or network IAQ with no OAT limits.
- 2- Outdoor Air Control Sensor A24 (A55_P114-12) (TB1-15).
- 3- Outdoor Air Control Sensor A24 (A55_P114_12) (TB1-15).with no OAT limits.

Some applications require a different CO₂ setpoint range than default settings. Damper "start open" (ECTO 5.17) and "full open" (ECTO 5.18) CO₂ setpoints may be adjusted from 0 to 1992ppm. Use the following formula to determine damper travel.

NOTE - When changing CO₂ setpoint range, "start open" setpoint should be less than "full-open" setpoint.

$$\% \text{ Damper Travel} = \left(\frac{\text{CO}_2\text{ppm} - \text{Start Open ppm}}{\text{Full Open} - \text{Start Open}} \right) \times \text{Max. Open (ECTO 5.16)}$$

For example: An application requires the dampers open at 800 CO₂ ppm and reach full open at 1200. If the CO₂ level in the space reads 1000 ppm, calculate the damper percent open as follows.

$$\left(\frac{1000 - 800}{1200 - 800} \right) = \left(\frac{200}{400} \right) = .5 \times 100 = 50\% \text{ Damper Travel}$$

Setpoint Control Option

Setpoint Control mode is commonly used in areas with high occupancy and frequent changeout such as classrooms or conference rooms.

In applications requiring this on/off damper response to CO₂ levels, set the “start open” (ECTO 5.17) setpoint higher than the “full open” (ECTO 5.18) setpoint. The dampers will drive to fully-open position immediately. Figure 40 shows the setpoint control option.

Change ECTO 5.19 and 5.20 to set the minimum outdoor temperature limits. Change ECTO 5.21 and 5.22 to set the maximum temperature value.

IMPORTANT - Mixed air temperatures less than 45°F (7°C) on units with an aluminized heat exchanger or less than 30°F (-1°C) on stainless steel heat exchangers will void the manufacturer’s warranty.

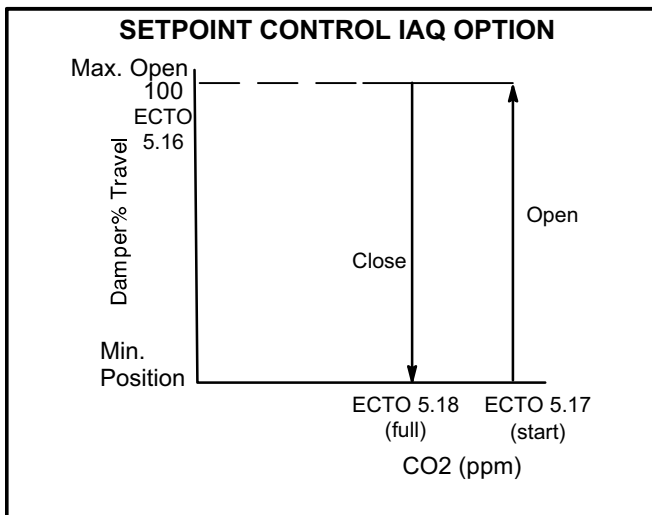

FIGURE 40

Determine IAQ Input

Check IAQ input (ppm) as follows:

- 1- Set the TEMP dip switch to ON.
- 2- Toggle the pushbutton to “co2”. The display will alternate between co2 and the IAQ input.
- 3- Multiply the reading by 10 to get CO₂ ppm.

OUTDOOR AIR CONTROL SENSOR (OAC)

An optional flow sensor (A24) may be used to control the amount of outdoor air brought into the space. If option 2 for ECTO 5.26 is selected, the IMC will modulate the outdoor air damper in order to hold a constant outdoor airflow. This option is very useful in VAV applications to maintain a constant outdoor airflow as the delivered air volume varies. A 0-10VDC flow meter located in the unit fresh air intake provides a signal to the general purpose board input A133_P194-6 (TB22-6). The IMC will modulate the damper based on ECTO 5.16 through 5.22 and ECTO 9.09-9.11 in order to maintain a constant air flow.

Adjust ECTO 5.19 through 5.22 to modify Outdoor Air Flow operation based on the outdoor air temperature. Select ECTO 5.26 option 3 when this option is not desired.

In OAC mode, the IMC closes the damper as voltage increases to maintain a constant amount of fresh air. The sensor will read 10VDC at maximum flow and 0VDC at minimum flow.

Field Wiring

When sensor is field-installed, connect as shown in figure 41.

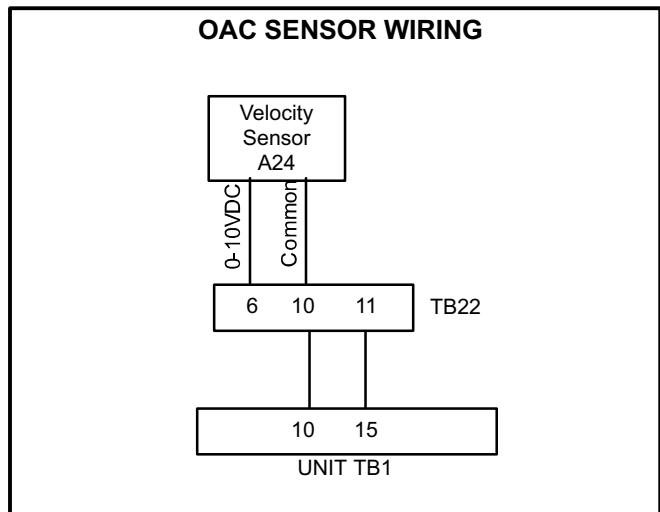

FIGURE 41

ECONOMIZER

Set Damper Minimum Position

- 1- Operate unit at full supply air CFM with all zone dampers open. Refer to VFD Supply Air Blower Start-Up section in this manual.
- 2- Use an air flow hood to measure the outdoor air CFM entering the unit.
- 3- Set economizer DIP switch to “DSET” position as shown in figure 42. DIP switch is located on the A56 economizer board.
- 4- Adjust the MIN POS SET potentiometer until the air flow hood reads the design minimum outdoor air CFM. See figure 42.

NOTE - Refer to local codes or authorities having jurisdiction when determining design minimum outdoor air requirements.

- 5- Return the A56 economizer board DIP switch to original position. Refer to the IMC manual.

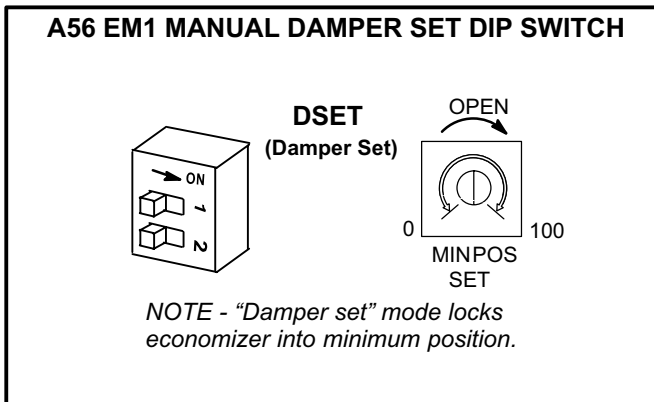

FIGURE 42

Set Velocity Setpoint

- 1- Turn the IMC MODE DIP “TEMP” switch ON. See figure 43. The IMC display will alternately flash from sensor readout to output value.
- 2- Press the pushbutton until “oAc” is displayed. The output value from the A24 velocity sensor will be displayed alternately with the oAc readout. Divide the A24 output value by 10 to determine the sensor voltage.

$$\text{Readout} \div 10 = \text{A24 Sensor Voltage}$$

_____ **Record Sensor Voltage Here**

- 3- Return the IMC MODE DIP “TEMP” switch to OFF.
- 4- Adjust ECTO 9.02 to the sensor voltage. Refer to the IMC manual provided with each rooftop unit.

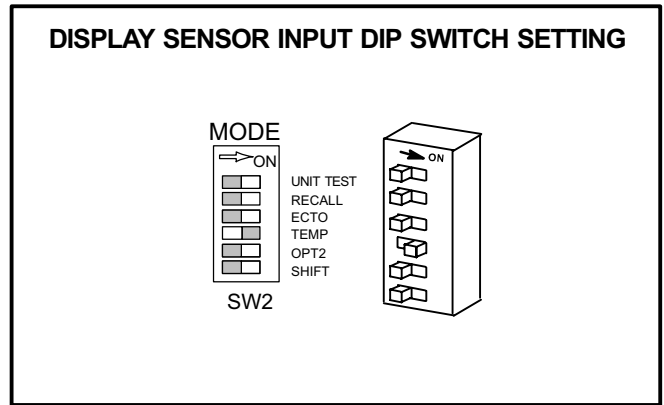

FIGURE 43

Velocity Sensor Range

The velocity sensor is factory-set for 0-5m/s. (0-984ft/min.) If a higher velocity is required, move the sensor jumper as shown in figure 44.

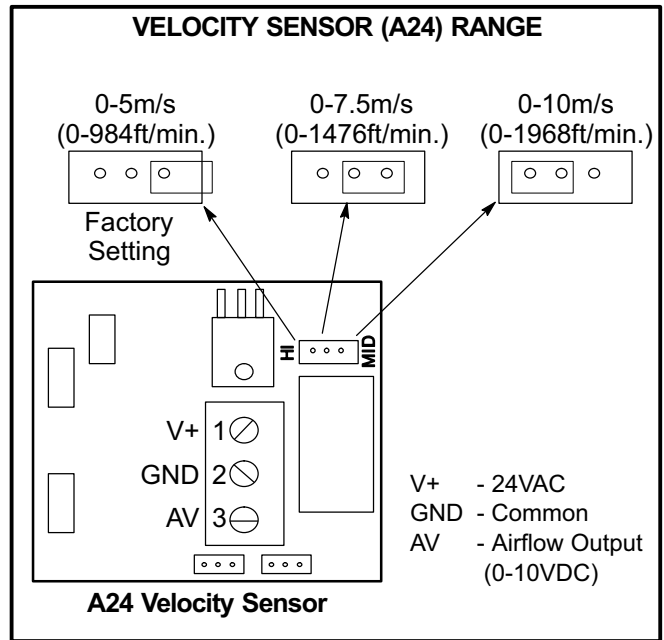

FIGURE 44

Outdoor Air Control ECTO Parameter Summary

Control Parameter		Control Value			Units	Description																																																								
No.	Name	Min	Default	Max.																																																										
5.17	OAC_Dampr_Start_Open_SP	0	2.51	10	R: Volt	Damper "start open" setpoint for Outdoor Air Control. Level where fresh air damper begins to open.																																																								
5.18	OAC_Dampr_Full_Open_SP	0	5.02	10	R: Volt	Damper "full open" setpoint for Outdoor Air Control. Level where fresh air damper is opened to maximum.																																																								
5.26	IAQ_Input_Source/Mode	0	0	3	Option	IAQ input source and mode. 0- DCV System IAQ. Either A55_P114-12 (TB1-15) or network IAQ 1- DCV System IAQ. Either A55_P114-12 (TB1-15) or network IAQ with no OAT limits. 2- Outdoor Air Control Sensor A24 (A133_P194-6) (TB22-6). 3- Outdoor Air Control Sensor A24 (A133_P194-6) (TB22-6) with no OAT limits.																																																								
9.01	A01_control_mode	0	0	11	Option	Analog output channel 1 control mode. 0 - No operation. Analog Output 1 off. <table border="0"> <tr> <td>Enabled When</td> <td>Control</td> </tr> <tr> <td>1- Occupied</td> <td>PID setpoint A</td> </tr> <tr> <td>Unoccupied</td> <td>PID setpoint B</td> </tr> <tr> <td>2- Occupied</td> <td>PID setpoint A</td> </tr> <tr> <td>Unoccupied</td> <td>Staged output B</td> </tr> <tr> <td>3- Occupied</td> <td>Staged output A</td> </tr> <tr> <td>Unoccupied</td> <td>PID setpoint B</td> </tr> <tr> <td>4- Occupied</td> <td>Staged output A</td> </tr> <tr> <td>Unoccupied</td> <td>Staged output B</td> </tr> <tr> <td>5- Blower On</td> <td>PID setpoint A</td> </tr> <tr> <td>Blower Off</td> <td>PID setpoint B</td> </tr> <tr> <td>6- Blower On</td> <td>PID setpoint A</td> </tr> <tr> <td>Blower Off</td> <td>Staged output B</td> </tr> <tr> <td>7- Blower On</td> <td>Staged output A</td> </tr> <tr> <td>Blower Off</td> <td>PID setpoint B</td> </tr> <tr> <td>8- Blower On</td> <td>Staged output A</td> </tr> <tr> <td>Blower Off</td> <td>Staged output B</td> </tr> <tr> <td>9 -DI2 (A133_P194-2) on</td> <td>PID setpoint B (1)</td> </tr> <tr> <td>DI1 (A133_P194-1) on</td> <td>PID setpoint A (2)</td> </tr> <tr> <td>Otherwise off</td> <td></td> </tr> <tr> <td>10-DI2 (A133_P194-2) on</td> <td>PID setpoint B (1)</td> </tr> <tr> <td>DI1 (A133_P194-1) on</td> <td>Staged output A (2)</td> </tr> <tr> <td>Otherwise off</td> <td></td> </tr> <tr> <td>11-DI2 (A133_P194-2) on</td> <td>Staged output B (1)</td> </tr> <tr> <td>DI1 (A133_P194-1) on</td> <td>Staged output A (2)</td> </tr> <tr> <td>Otherwise off</td> <td></td> </tr> <tr> <td>(1) -DI1 (A133_P194-2) doesn't matter</td> <td></td> </tr> <tr> <td>(2) -DI2 (A133_P194-1) is off</td> <td></td> </tr> </table>	Enabled When	Control	1- Occupied	PID setpoint A	Unoccupied	PID setpoint B	2- Occupied	PID setpoint A	Unoccupied	Staged output B	3- Occupied	Staged output A	Unoccupied	PID setpoint B	4- Occupied	Staged output A	Unoccupied	Staged output B	5- Blower On	PID setpoint A	Blower Off	PID setpoint B	6- Blower On	PID setpoint A	Blower Off	Staged output B	7- Blower On	Staged output A	Blower Off	PID setpoint B	8- Blower On	Staged output A	Blower Off	Staged output B	9 -DI2 (A133_P194-2) on	PID setpoint B (1)	DI1 (A133_P194-1) on	PID setpoint A (2)	Otherwise off		10-DI2 (A133_P194-2) on	PID setpoint B (1)	DI1 (A133_P194-1) on	Staged output A (2)	Otherwise off		11-DI2 (A133_P194-2) on	Staged output B (1)	DI1 (A133_P194-1) on	Staged output A (2)	Otherwise off		(1) -DI1 (A133_P194-2) doesn't matter		(2) -DI2 (A133_P194-1) is off	
Enabled When	Control																																																													
1- Occupied	PID setpoint A																																																													
Unoccupied	PID setpoint B																																																													
2- Occupied	PID setpoint A																																																													
Unoccupied	Staged output B																																																													
3- Occupied	Staged output A																																																													
Unoccupied	PID setpoint B																																																													
4- Occupied	Staged output A																																																													
Unoccupied	Staged output B																																																													
5- Blower On	PID setpoint A																																																													
Blower Off	PID setpoint B																																																													
6- Blower On	PID setpoint A																																																													
Blower Off	Staged output B																																																													
7- Blower On	Staged output A																																																													
Blower Off	PID setpoint B																																																													
8- Blower On	Staged output A																																																													
Blower Off	Staged output B																																																													
9 -DI2 (A133_P194-2) on	PID setpoint B (1)																																																													
DI1 (A133_P194-1) on	PID setpoint A (2)																																																													
Otherwise off																																																														
10-DI2 (A133_P194-2) on	PID setpoint B (1)																																																													
DI1 (A133_P194-1) on	Staged output A (2)																																																													
Otherwise off																																																														
11-DI2 (A133_P194-2) on	Staged output B (1)																																																													
DI1 (A133_P194-1) on	Staged output A (2)																																																													
Otherwise off																																																														
(1) -DI1 (A133_P194-2) doesn't matter																																																														
(2) -DI2 (A133_P194-1) is off																																																														
9.02	AO1_SP_A	0 0 -0.5 0	127 5.00 0 2.5	255 10.0 0.5 5.0	Counts R:Volts M:"w.c. N:"w.c.	Analog output channel 1 setpoint A																																																								
9.09	AO1_PID_P_Constant	0	0	127	Counts	Analog output channel 1 PID loop proportional constant.																																																								
9.10	AO1_PID_I_Constant	0	0	127	Counts	Analog output channel 1 PID loop integral constant.																																																								

ECONOMIZER

Service Relay

Service Relay Operation

The IMC Service Relay output (A55_P113-3) (TB1-19) default operation indicates that service is required. Table 4 indicates these critical alarms with an asterisk.

If the default operation is not required, the Service Relay

output may be used as a control output. Use ECTO 7.22 to choose the input which will trigger the Service Relay output. The formula $X + (32 \times Y) + (16 \times Z)$ is used to select the option. See table 34.

If ECTO 7.22 input sources 7-9 are used, the setpoint and deadband must be set with ECTO 7.23 and 7.24.

TABLE 34

Service Relay Options						
Control Parameter		Control Value			Units	Description
No.	Name	Min	Default	Max.		
7.22	Service_ Output_ Control_Mode	0	0	127	Option	<p>A55 Service Output Control Mode = $X + 32*Y + 16*Z$</p> <p>Input source = X:</p> <ul style="list-style-type: none"> 0- None. Standard Service Output based on alarms. 1- Compressor 1 duty cycle. (Compressor crankcase heater function.) On when OAT \leq ECTO 7.23 and \geq ECTO 7.24 seconds have passed with compressor 1 off. Off when OAT $>$ ECTO 7.23 + 3 deg F (fixed deadband) or $<$ ECTO 7.24 seconds have passed with compressor 1 off 2- On when occupied. 3- On when blower on, 4- On when heating demand. 5- On when cooling demand. 6- On when heating or cooling demand. 7- System RH (Either A55_P114-10 or network RH) 8- System IAQ. (Either A55_P114-12 or network IAQ) 9- System OAT (Either A55_P114-13/14 or network OAT) <p>Algorithm Y for input sources 7-9:</p> <ul style="list-style-type: none"> 0 – Hysteresis loop On when input \geq ECTO 7.23 Off when input $<$ ECTO 7.23-ECTO 7.24 1—Window On when input is in range; \geq ECTO 7.25 and \leq ECTO 7.23 + ECTO 7.24 (Fixed 3-count hysteresis loop on rising and falling edges of window.) 2 - Delayed-on. On when input is \geq ECTO 7.23 for \geq ECTO 7.24 seconds. Off when input is $<$ ECTO 7.23-3. (Fixed 3-count hysteresis loop on edge.) 3 - Delayed-off. On when input is \geq ECTO 7.23. Off when input is $<$ ECTO 7.23 - 3 for \geq ECTO 7.25 seconds. (Fixed 3-count hysteresis loop on edge.) <p>Inversion Z:</p> <ul style="list-style-type: none"> 0 - Output not inverted. 1 - Output inverted.
7.23	Service_ Output_SP	0 0 0 132	127 996 100 51	255 2000 100 -31	Counts I:ppm P: % Y:DegF	<p>A55 service relay output setpoint.</p>

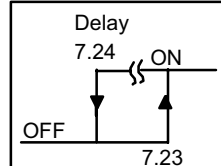
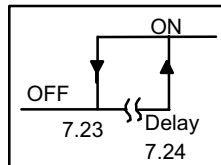
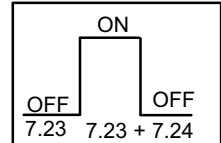
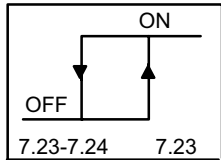

Graphs indicate output not inverted. See figure 48.

7.24	Service Output_DB	2	13	255	Counts I:ppm P: % O:DegF D:Sec.	A55 service relay output deadband or delay.
		16	102	2000		
		2	13	100		
		1	8	162		
		64	416	8160		

Example 1:

Use the Service output to energize a dehumidifier at 60% RH and turn off at 55% RH.

1- Determine:

ECTO 7. 22- Input Source X to option "7" (RH)

Algorithm Y to option "0" (hysteresis loop)

Inversion Z option "0" (output not inverted)

2- Apply step 1 to ECTO 7.22 formula:

$$\begin{aligned} \text{ECTO 7.22} &= X + (32 \times Y) + (16 \times Z) \\ &= 7 + (32 \times 0) + (16 \times 0) \\ &= 7 \end{aligned}$$

3- Set ECTO 7.22 to "7".

4- Set ECTO 7.23 to 60% (60 counts) for 60% RH

5- Set ECTO 7.24 to 5% (5 counts) for 5% deadband.

Refer to figure 45.

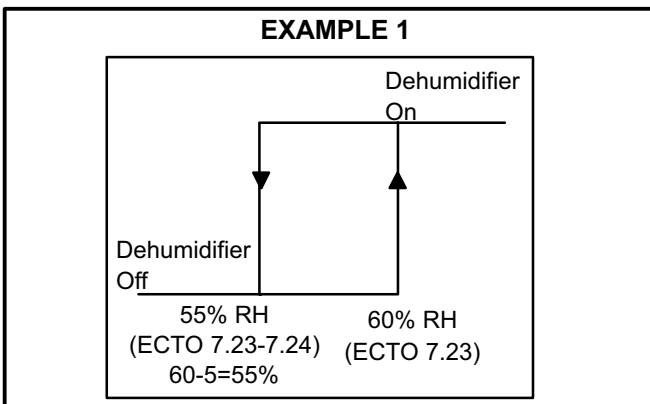

FIGURE 45

Example 2:

Use the service output to energize a humidifier at 30% RH and turn off at 35% RH.

1- Determine:

ECTO 7. 22- Input Source X to option "7" (RH)

Algorithm Y to option "0" (hysteresis loop)

Inversion Z option "1" (output inverted)

2- Apply step 1 to ECTO 7.22 formula:

$$\begin{aligned} \text{ECTO 7.22} &= X + (32 \times Y) + (16 \times Z) \\ &= 7 + (32 \times 0) + (16 \times 1) \\ &= 7 + 0 + 16 \\ &= 23 \end{aligned}$$

3- Set ECTO 7.22 to "23".

4- Set ECTO 7.23 to 35% (60 counts) for 35% RH

5- Set ECTO 7.24 to 5% (5 counts) for 5% deadband.

Refer to figure 46.

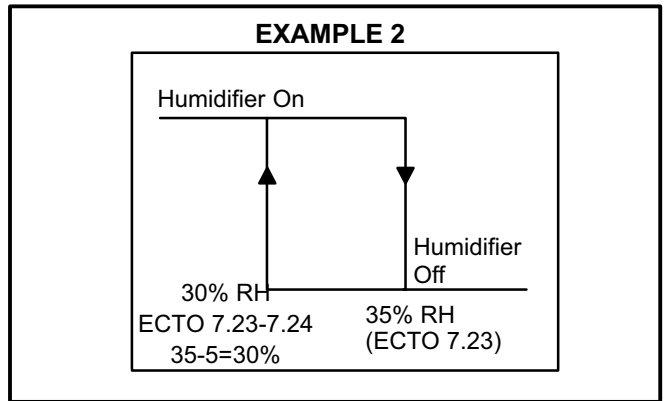

FIGURE 46

OAT Operation

Figure 47 shows the service output being energized at 80°F and off at 70°F (inverted). Figure 48 shows the service output operation being energized at 70°F and off at 80°F (not inverted).

IMPORTANT - This applies to input source option 9 (OAT) on ECTO 0.23, 3.21, 7.22, and 9.23.

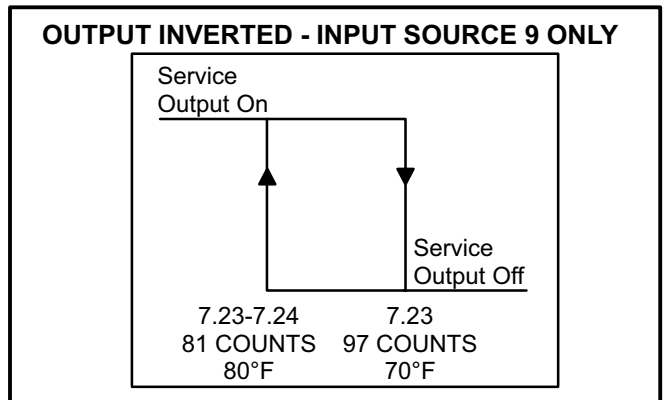

FIGURE 47

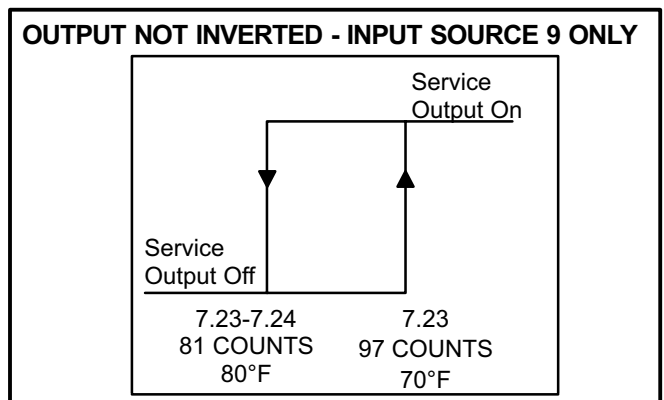

FIGURE 48

Testing Unit Function

IMC MANUAL OUTPUT TEST

The IMC board provides analog and digital test outputs to check operation of the unit functions shown in table 35. See the Modulating Gas Valve section to test operation.

**TABLE 35
TESTING OUTPUTS**

Read-out	Output Energized	Function	Output
0	.0	Blower	K3
1	.1	Fan 1 ⁽¹⁾	K10
2	.2	Fan 2 ⁽¹⁾	K68
3	.3	Fan 3 ⁽¹⁾	K149
4	.4	Fan 4 ⁽¹⁾	K150
5	.5	Fan 5 ⁽¹⁾	K152
6	.6	Fan 6 ⁽¹⁾	K153
7	.7	Reversing Valve 1	L1
8	.8	Reversing Valve 2	L2
9	.9	Service Relay	SR
10	1.0	Reheat Solenoid	L14
11	1.1	Reheat Solenoid	L30
12	1.2	Exhaust Fan Stg. 1 / VFD Enable	K65
13	1.3	Exhaust Fan Stg. 2	(TB18-5)
14*	14	VAV A01 ²	(TB18-11)
15*	15	VAV A02 ³	(TB18-12)
16	1.6	GP Relay Out	(TB22-5)
17*	17	GP AO1	(TB22-11)
18*	18	GP AO2	(TB22-12)

*Analog outputs

(1) Fans which are controlled by a low ambient pressure switch will not be energized.

(2) Supply VFD speed or CAVB damper control.

(3) Exhaust fan VFD speed control

Check unit functions as follows.

1-Move the MODE DIP "UNIT TEST" to ON. See figure 49.

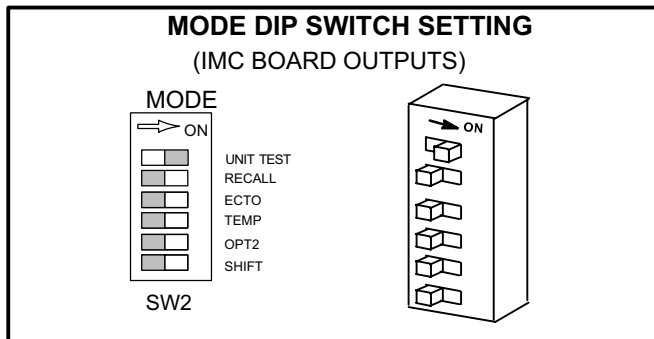

FIGURE 49

The readout will display "0" indicating a blower output. See figure 50.

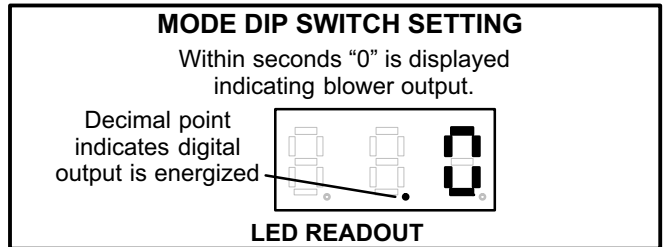

FIGURE 50

2-Press the pushbutton to toggle the readout upward from 0 to 18. Press the pushbutton twice (double push) to toggle the output downward from 9 to 0.

3-When the readout for the desired unit function is displayed, press and hold the pushbutton to turn "ON" the digital output and energize the function. A decimal point will appear when the output is energized.

4-Turn the output "OFF" by pressing down on the pushbutton until the decimal disappears.

Analog outputs only (14, 15, 17, 18) -

Move the MODE DIP "SHIFT" to ON. See figure 51. 0-100% is equivalent to a 0-10vdc analog output. A single push on the pushbutton increases the readout 1% or .1 volts. A double push decreases the output by 10% or 1 volt. Advance to the desired percentage or voltage. Press and hold the pushbutton to send the value to the analog output.

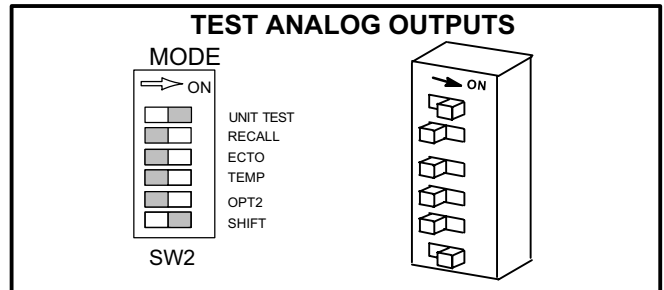

FIGURE 51

5-When output testing is completed, turn MODE DIP switches off. The IMC board will reset.

The display will read E if DIP switches have been set incorrectly. See figure 52.

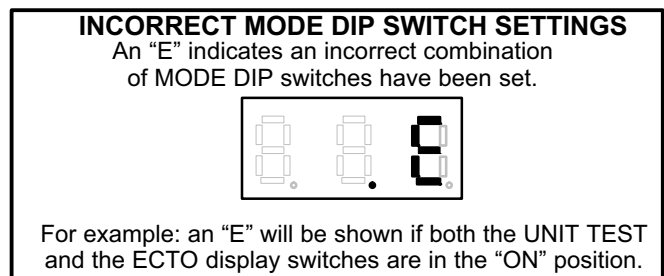

FIGURE 52

Example For Digital Outputs:

To check fan 3 operation (see figure 53):

- 1-Set MODE DIP to "UNIT TEST".
- 2-With a short press, toggle pushbutton until number 3 is indicated.
- 3-Press pushbutton until decimal appears; fan three will be energized.
- 4-Press pushbutton until decimal goes off; fan three will be de-energized.

Note - When a low ambient switch is used on fan three, the fan will not be energized.

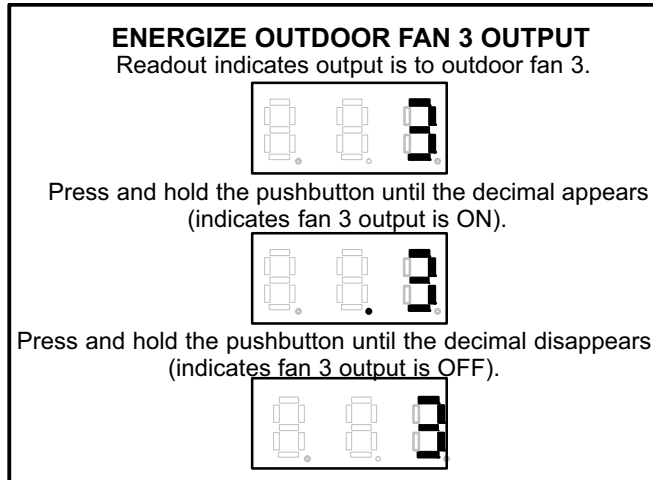

FIGURE 53

Example For Analog Outputs:

To check variable speed blower operation (see figure 54):

- 1-Set MODE DIP to "UNIT TEST".
- 2-Readout will indicate output is for the blower (display will read 0).
- 3-Press pushbutton until decimal appears (this will enable the blower).

4-With a short press, toggle pushbutton until number 14 is displayed.

5-Set the MODE DIP "SHIFT" to on.

6-With a short press, toggle pushbutton to increase readout 1%, a double push to decrease readout 10%.

7-After the desired output is set, press and hold pushbutton to send the value to the analog output.

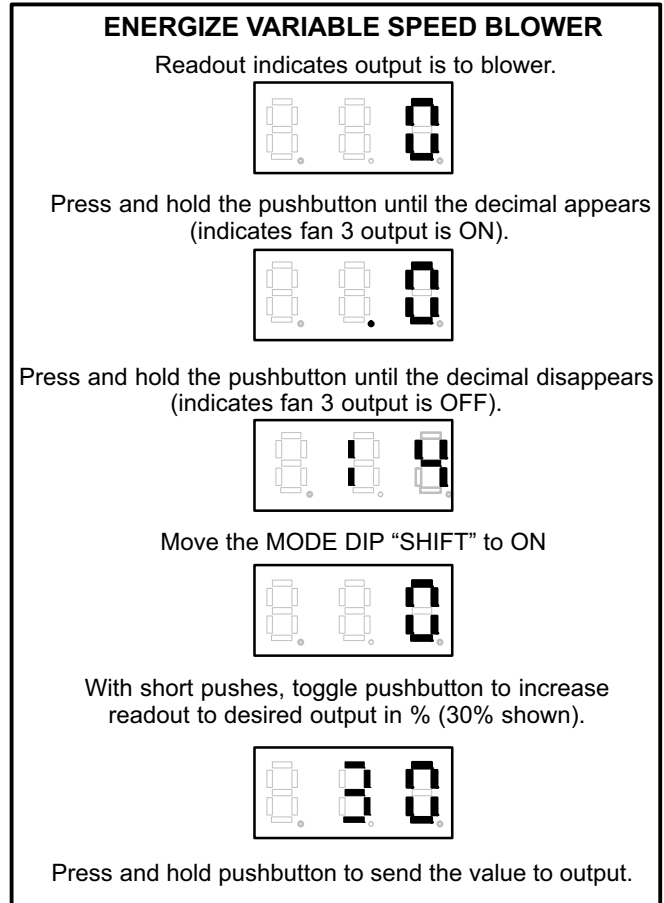

FIGURE 54

IMC TWO-STAGE THERMOSTAT SIMULATION TEST

The IMC simulates two-stage thermostat inputs to check unit operation. In the test mode, thermostat inputs and zone sensor control are ignored by the M1-7.

- 1-Move the UNIT DIP "SHIFT" to ON. Make sure the decimal point is to the right of the readout.
- 2-Move the MODE DIP "UNIT TEST" to "ON". See figure 55.

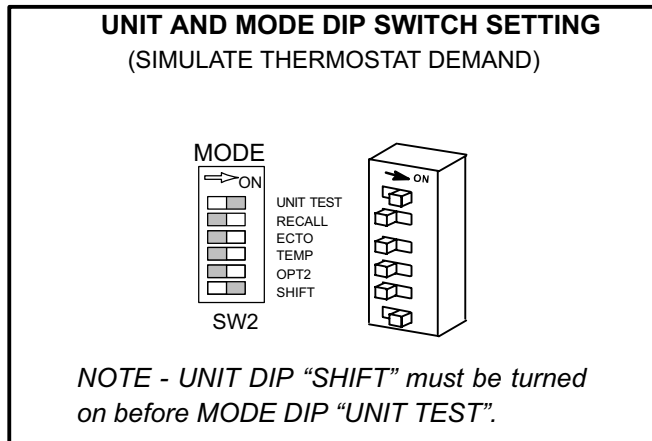

FIGURE 55

For a few seconds only a decimal point will be displayed. Then a "c01" will be displayed simulating a thermostat input.

- 3-Use the pushbutton to toggle the readout upward from "c01" to "S01",. A double push will toggle the readout downward from "S01" to "c01". Table 36 shows test inputs on two-stage units (ECTO 5.04 set to 1 or 2). Table 37 shows test inputs for three-stage units (ECTO 5.04 set to 3).

NOTE - When a cooling stage is de-energized, all lower stages are de-energized simultaneously.

TABLE 36
TESTING INPUTS (TWO-STAGE)

Read-out	Input Energized	Thermostat Input Simulation	Function
c 0	c 0 .	Y1 & G	1st Stage Cooling
c 1 0	c 1 . 0	Y2 & G	1st & 2nd Stage Cooling
c 1 1	c 1 . 1	Y1, Y2, & G	1st & 2nd Stage Cooling
h 0	h 0 .	W1	1st Stage Heating
h 1 0	h 1 . 0	W2	Gas & Electric - 1st & 2nd Stage Heating Heat Pump - Em. Heat
h 1 1	h 1 . 1	W1 & W2	1st & 2nd Stage Heating
5 0	5 0 .	SMOKE	Unit Off (Default)

TABLE 37
TESTING INPUTS (THREE-STAGE)

Read-out	Input Energized	Thermostat Input Simulation	Function
c 0	c 0 .	Y1 & G	1st Stage Cooling
c 1 0	c 1 . 0	Y2 & G	1st & 2nd Stage Cooling
c 1 1	c 1 . 1	Y1, Y2, & G	3rd Stage Cooling
h 0	h 0 .	W1	1st Stage Heating
h 1 0	h 1 . 0	W2	Gas & Electric - 1st & 2nd Stage Heating Heat Pump - Em. Heat
h 1 1	h 1 . 1	W1 & W2	1st & 2nd Stage Heating
5 0	5 0 .	SMOKE	Unit Off (Default)

- 2-Press and hold the pushbutton to turn "ON" an output. A decimal indicates the output is energized. Press and hold the pushbutton until the decimal disappears. This indicates the output is turned "OFF". See figure 56.

Example:

To check compressor operation:

- 1-Set UNIT DIP to "OPT1". Set MODE DIP to "UNIT TEST".
- 2-With a short push, toggle pushbutton until "c11" is indicated.
- 3-Press pushbutton until decimal appears; all compressors will be energized.

NOTE - Units may have more than one compressor per stage of cooling. Refer to unit wiring schematic to determine which compressors are energized by first- and second-stage cooling demands.

Turning off the MODE DIP "UNIT TEST" and UNIT DIP "OPT1" returns unit to normal operation and resets all delays except blower off delays used with compressor operation.

Reset power to digital temperature control modules once tests are complete. This will reset any alarms which may have been caused by testing.

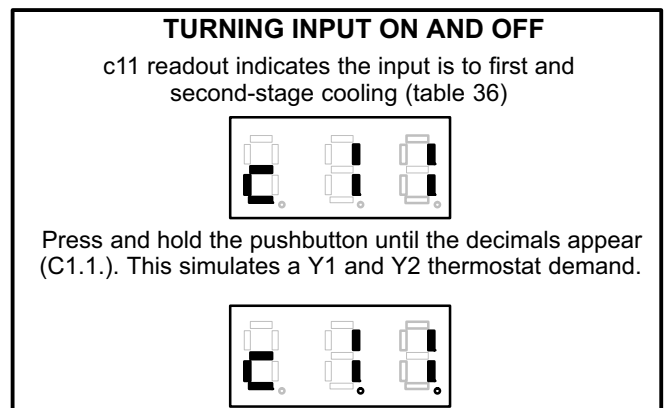

FIGURE 56

Displaying Sensor Readings

Sensor temperature, IAQ sensor voltage, analog inputs, and economizer damper position may be read on the M1-7 display.

Turn MODE DIP "TEMP" ON, as shown in figure 57, to read the outputs shown in table 38.

Display will alternately flash from readout to output.

The display will read E to indicate a wrong combination of DIP switches have been set. See figure 58.

A single push on the pushbutton will toggle the readout upward and a double push will toggle the readout downward. See table 38. A long push will bypass time delays.

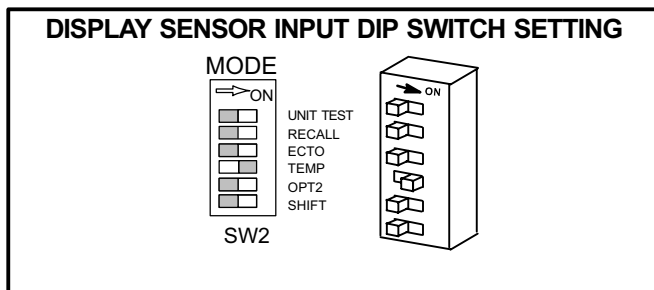

FIGURE 57

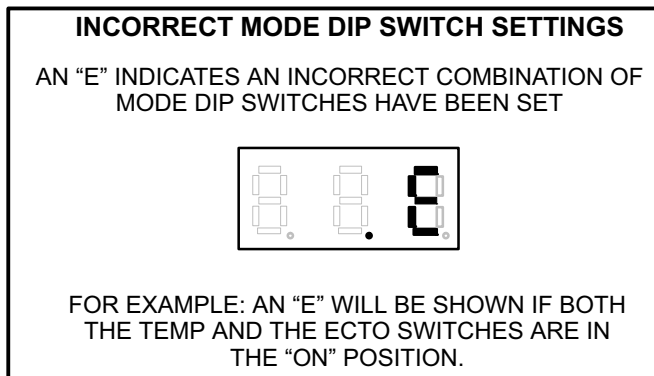

FIGURE 58

**TABLE 38
READ SENSOR OUTPUT**

READ-OUT	OUTPUT
oA	Outdoor Air Temperature - °F (RT17)
rA	Return Air Temperature - °F (RT16)
dA	Discharge Air Temperature - °F (RT6)
A2	Zone Air Temperature - (A2 - Optional)
co2	IAQ Sensor - ppm/10 (A63 - Optional)
oAc	OAC Sensor - Volt x 10 (A24 Optional)
Ecc2	IAQ Economizer Damper Position - % (Optional)
Eco	Economizer Damper Position - % (Optional)
rH	Indoor Relative Humidity - % (A91/A37-Optional)

DEGREES CELSIUS (°C)

Change ECTO parameter 5.03 to option to display all temperature in °C.

TEMPERATURE SENSORS

RT6 monitors supply air temperature. RT16 monitors return air temperature. The main function of RT6 and RT16 is controlling the economizer. Both are also used for diagnostic purposes.

RT17 monitors outdoor air temperature. RT17 is used when controlling low ambient fan cycling, low ambient compressor lockout, strike three control, high ambient strip heat lockout, economizer control, and other control functions.

Outdoor, return, supply, and zone air sensor temperatures are displayed to the nearest degree.

NOTE - RT6, RT16, and RT17 do not sense "enthalpy", or total heat content of air.

Outdoor, return air, and supply air sensors are factory-provided and installed. Zone air sensors are field-provided and installed.

IAQ SENSOR OUTPUT VOLTAGE

IAQ sensors are field-provided and installed. Sensors interface with standard modulating economizers to bring in outdoor air when CO₂ levels are high. The IAQ input is compatible with IAQ sensors which have a 0-10VDC output and a CO₂ range of 0-2000ppm.

Toggle pushbutton to co2 to read IAQ sensor output. The display will read between 0 and 200. See table 39 or divide the reading by 20 to calculate the IAQ sensor output voltage. Multiply the reading by 10 to calculate the sensor CO₂ ppm.

**TABLE 39
READ SENSOR OUTPUT**

Readout	Sensor Voltage	CO ₂ ppm
0	0	0
20	1	200
40	2	400
60	3	600
80	4	800
100	5	1000
120	6	1200
140	7	1400
160	8	1600
180	9	1800
200	10	2000

Example:

- 1- Set MODE DIP "TEMP" to "ON".
- 2- Toggle pushbutton until c02 reading is alternately flashing with an output reading. Figure 59 shows an output reading of 100.
- 3- Divide output reading by 20 to get IAQ sensor output voltage. See figure 59.

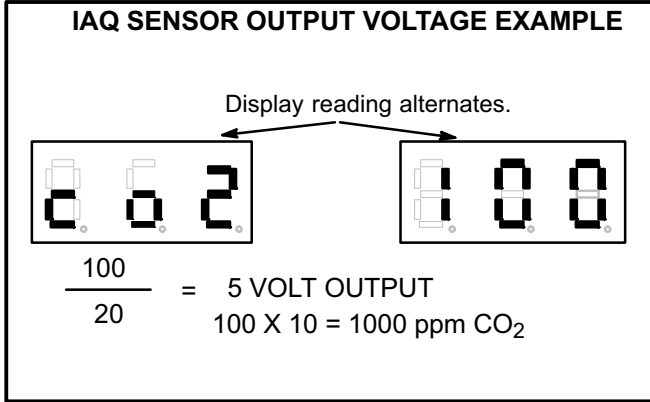

FIGURE 59

ECONOMIZER DAMPER POSITION

Readout Eco displays the damper motor feedback in percent open. The feedback range for the economizer motor is 2-10vdc. Voltage is read at P115 pins 1 and 9. Note - The readout can have up to a 20-second delay.

**TABLE 40
DAMPER POSITION**

Voltage Feedback	Damper % Open
2.00	0
3.00	13
4.00	25
6.00	38
6.00	50
7.00	63
8.00	75
9.00	88
10.00	100

GENERAL PURPOSE GP1 BOARD INPUTS

Read analog and digital inputs to the GP1 (A133) board.

- 1-Set MODE DIP "OPT2" to ON.

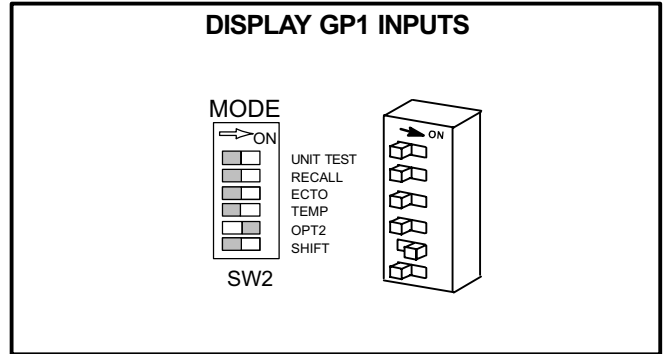

FIGURE 60

- 2-Toggle pushbutton to readout number of the input to be read. A single push will advance to the next readout and a double push will move to the previous input.

Display will alternate between the readout number and the readout value. See tables 41 through 46. Reference terminal block designations in figure 13. The GP1 board is used in three different applications: variable air volume (VAV), modulating gas valve (MGV), and general purpose (GP). Make sure the readout matches the use of the GP1 board.

**TABLE 41
GP1 DIGITAL INPUTS VAV A133(1)**

Readout Number	Readout	Digital Inputs	
		DI2 TB18-2	DI1 TB18-1
1	00	Off	Off
	01	Off	On
	10	On	Off
	11	On	On

**TABLE 42
GP1 ANALOG INPUTS VAV A133(1)**

Readout No.	Readout	Analog Input	Read-out=Volts (DC)	Supply Static "w.c."	Building Static "w.c."
2	0-255	AI1 (TB18-6) 0-10vdc=0 to 5"w.c. Supply Static Pr.	0 = 0.00 25 = 0.98 50 = 1.96	= 0.00 = 0.50 = 1.00	= -0.5 = -0.4 = -0.3
3	0-255	AI2 (TB18-7)0-10vdc=-0.5 to 0.5"w.c. Bldg. Static Pr.	75 = 2.94 100 = 3.92 125 = 4.90	= 1.50 = 2.00 = 2.50	= -0.2 = -0.1 = 0.0
4	0-255	AI3 (TB18-8) 0-10vdc	150 = 5.88 175 = 6.86	= 3.00 = 3.50	= 0.1 = 0.2
5	0-255	AI4 (TB18-9) 0-10vdc	200 = 7.84 225 = 8.82 255 = 10.00	= 4.00 = 4.50 = 5.00	= 0.3 = 0.4 = 0.5

**TABLE 43
GP1 DIGITAL INPUTS GP A133(3)**

Readout Number	Readout	Digital Inputs	
		DI2 TB22-2	DI1 TB22-1
6	00	Off	Off
	01	Off	On
	10	On	Off
	11	On	On

**TABLE 45
GP1 DIGITAL INPUTS MGV A133(2)**

Readout Number	Readout	Digital Inputs	
		DI2 TB22-2	DI1 TB22-1
11	00	Off	Off
	01	Off	On
	10	On	Off
	11	On	On

**TABLE 44
GP1 ANALOG INPUTS GP A133(3)**

Readout Number	Read-out	Analog Input	Readout=Volts (DC)
7	0-255	AI1 (TB22-6) 0-10vdc	0 = 0.00 25 = 0.98 50 = 1.96
8	0-255	AI2 (TB22-7) 0-10vdc	75 = 2.94 100 = 3.92 125 = 4.90
9	0-255	AI3 (TB22-8) 0-10vdc	150 = 5.88 175 = 6.86 200 = 7.84
10	0-255	AI4 (TB22-9) 0-10vdc	225 = 8.82 255 = 10.00

**TABLE 46
GP1 ANALOG INPUTS MGV A133(2)**

Readout Number	Read-out	Analog Input	Readout=Volts (DC)
12	0-255	AI1 (TB19-6) 0-10vdc	0 = 0.00 25 = 0.98 50 = 1.96
13	0-255	AI2 (TB19-7) 0-10vdc	75 = 2.94 100 = 3.92 125 = 4.90
14	0-255	AI3 (TB19-8) 0-10vdc	150 = 5.88 175 = 6.86 200 = 7.84
15	0-255	AI4 (TB19-9) 0-10vdc	225 = 8.82 255 = 10.00

Sensors

The IMC is only compatible with L Connections sensors provided with the unit or purchased separately as specified in the Engineering Handbook.

IMPORTANT - All 0-10VDC sensors require two separate twisted pair cables with shield. One cable is used for the 24VAC power and one cable is used for the 0-10VDC output. Zone sensors require a single twisted pair cable with shield. The shield drain wires must be connected to the common at the unit field wiring terminal block only. The shield drain wires must not be connected to common at the sensor.

Temperature Sensors - Provided With Unit

The return air (RT16) and discharge air (RT6) duct probes and the outdoor air (RT17) are all two wire thermistors. The resistance vs. temperature table is shown below:

Temp. °F	Temp. °C	Resistance +/-2%
-40	-40.0	335,671
-20	-28.9	164,959
0	-17.8	85,323
20	-6.7	46,218
30	-1.1	34,566
40	4.4	26,106
50	10.0	19,904
60	15.6	15,313
70	21.1	11,884
80	26.7	9,298
90	32.2	7,332
100	37.8	5,826
120	48.9	3,756
130	54.4	3,047

Optional Zone Sensor

Zone sensors (A2) are two wire thermistor with 1K series resistor.

Temp. °F	Temp. °C	Resistance +/-2%
40	4.4	27,102
45	7.2	23,764
50	10.0	20,898
55	12.8	18,433
60	15.6	16,313
65	18.3	14,474
70	21.1	12,882
75	23.9	11,498
80	26.7	10,299
85	29.4	9,249
90	32.2	7,529

Optional Relative Humidity Sensor

The indoor RH sensor (A91) is an analog sensor with a 0-10 VDC output over an RH range of 0-100%RH. The sensor is powered with 24VAC.

Optional CO₂ (IAQ) Sensor

The indoor CO₂ sensor (A63) is an analog sensor with a 0-10VDC output over a CO₂ range of 0-2000ppm. The sensor is powered with 24VAC.

CO ₂ PPM	DC Voltage
0	0
200	1.0
400	2.0
600	3.0
800	4.0
1000	5.0
1200	6.0
1400	7.0
1600	8.0
1800	9.0
2000	10.0

Optional Supply Static Pressure Sensor

The supply duct differential static pressure sensor (A30) is an analog sensor with a 0-10VDC output over a range of 0-5"w.c. The sensor is powered with 24VAC.

Pressure "w.c.	DC Voltage
0	0
0.5	1.0
1.0	2.0
1.5	3.0
2.0	4.0
2.5	5.0
3.0	6.0
3.5	7.0
4.0	8.0
4.5	9.0
5.0	10.0

Optional Building or Return Static Pressure Sensor

The building static differential static pressure sensor (A34) is an analog sensor with a 0-10VDC output over a range of -0.5 to 0.5”w.c. The sensor is powered with 24VAC.

Pressure ”w.c.	DC Voltage
-0.5	0
-0.4	1.0
-0.3	2.0
-0.2	3.0
-0.1	4.0
0.0	5.0
0.1	6.0
0.2	7.0
0.3	8.0
0.4	9.0
0.5	10.0

Optional Enthalpy Sensor

The optional enthalpy sensors (A7 and A63) used with the economizer have an output of 4-20mA. The sensor is powered with 24VAC. See table 33.

OAC Sensor

The optional outdoor air control sensor is an analog sensor with a 0-10VDC output. Three velocity ranges are available. See table 47. The sensor is powered with 24VAC.

TABLE 47

Sen- sor Volts	IMC Read- out	0-5m/sec		0-7.5 m/sec		0-10 m/sec	
		m/ sec.	ft/ min.	m/ sec.	ft/ min.	m/ sec.	ft/ min.
0.00	0	0.00	0	0.00	0	0.00	0
0.50	5	0.25	49	0.38	74	0.50	98
1.00	10	0.50	98	0.75	148	1.00	197
1.50	15	0.75	148	1.13	221	1.50	295
2.00	20	1.00	197	1.50	295	2.00	394
2.50	25	1.25	246	1.88	369	2.50	492
3.00	30	1.50	295	2.25	443	3.00	590
3.50	35	1.75	344	2.63	517	3.50	689
4.00	40	2.00	394	3.00	590	4.00	787
4.50	45	2.25	443	3.38	664	4.50	886
5.00	50	2.50	492	3.75	738	5.00	984
5.50	55	2.75	541	4.13	812	5.50	1082
6.00	60	3.00	590	4.50	886	6.00	1181
6.50	65	3.25	640	4.88	959	6.50	1279
7.00	70	3.50	689	5.25	1033	7.00	1378
7.50	75	3.75	738	5.63	1107	7.50	1476
8.00	80	4.00	787	6.00	1181	8.00	1574
8.50	85	4.25	836	6.38	1255	8.50	1673
9.00	90	4.50	886	6.75	1328	9.00	1771
9.50	95	4.75	935	7.13	1402	9.50	1870
10.00	100	5.00	984	7.50	1476	10.00	1968

Third-Party Zoning

The IMC has many features which allow easy interface with Third-party VAV or Bypass Damper Changeover zoning systems. See figure 61 for a VAV unit wiring summary and figure 62 for a CAV unit w/CAVB wiring summary.

In addition to providing VFD control (VAV units) and bypass damper control (CAV units), the IMC provides discharge air control for cooling and/or heating. More options are available which control single stage, two stage, or modulating power exhaust fans.

Only 4 digital inputs are required to control the rooftop unit

for third-party zoning applications: G (blower enable), OCP (occupied), Y1 (enables discharge cooling) and W1 (enables discharge heating).

Air Delivery Operation

When a G signal is energized the IMC will control a VFD or bypass damper to hold a constant supply duct static pressure. The IMC uses a pressure sensor input and a PID control loop to maintain duct static pressure. For increased flexibility, the IMC has separate adjustable static pressure setpoints for ventilation, cooling, heating and smoke alarms.

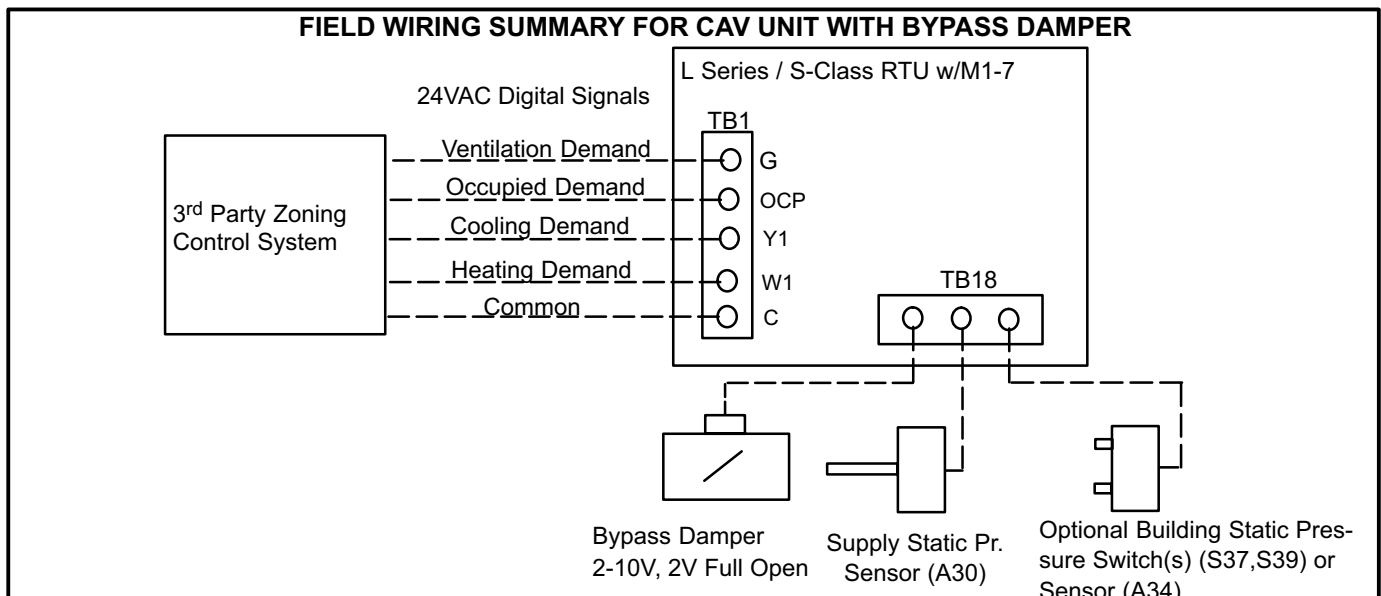
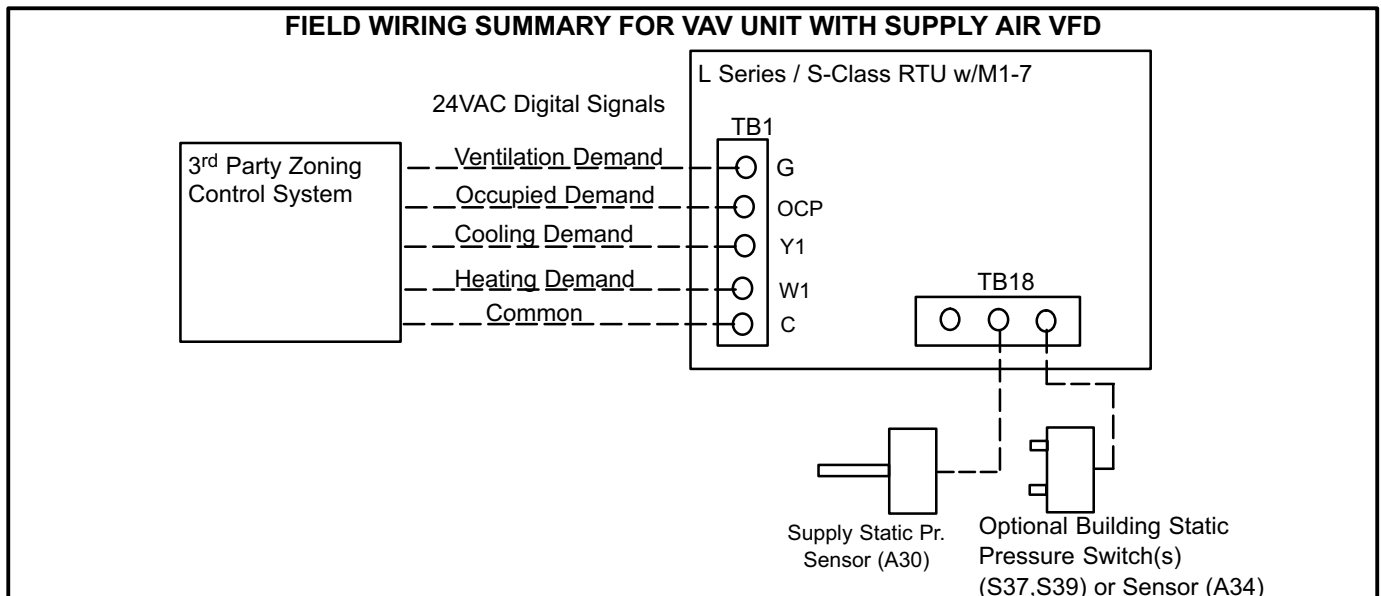

Occupied /Unoccupied Operation

When the OCP signal is energized the IMC will adjust the fresh air damper to a fixed minimum position or a modulating position (based on a CO2 or outdoor air control sensor). Also during morning warmup/cooldown the IMC will keep the damper closed based on the settings selected.

Cooling Operation

When a Y1 signal is energized the IMC will control up to 4 stages of cooling (depending RTU size) to automatically maintain a constant discharge air cooling temperature. The IMC also has advanced discharge air cooling reset options based on return air temperature and/or outside air temperature.

DACC Outdoor Air Reset

The outside air reset saves energy by gradually increasing the discharge air setpoint as the outside air temperature decreases.

DACC Return Air Reset

The return air reset reduces the possibility of overcooling by gradually increasing the discharge air setpoint as the return air temperature decreases. Overcooling may occur if the zoning system is misapplied, has an abnormal condition, or a dominant zone.

Heating Operation

When a W1 signal is energized the IMC will control up to 4 stages of heating (depending on RTU size) to automatically maintain a constant discharge air heating temperature. The IMC also has advanced discharge air heating reset options based on return air temperature and/or outside air temperature.

DACH Outdoor Air Reset

The outside air reset saves energy by gradually decreasing the discharge air setpoint as the outside air temperature increases.

DACH Return Air Reset

The return air reset reduces the possibility of overheating by gradually decreasing the discharge air setpoint as the return air temperature increases. Overheating may occur if the zoning system is miss-applied, has an abnormal condition, or dominant zone.

Power Exhaust Operation

The IMC has many power exhaust fan control options that include single stage, two stage and modulating control depending on how the unit is equipped. The stage control options can be triggered based on fresh air damper position, pressure switches or pressure analog sensor. The modulating control for units with VFD powered exhaust fans are typically modulated to maintain building

static pressure, but can also be staged. See power exhaust section.

VAV and CAVB Analog Outputs

Refer to the Supply Air Delivery section and the Optional Power Exhaust Fan section.

VFD Control

The IMC is only compatible with the factory-installed variable frequency drives (VFD) provided in VAV units. The VFD is used to control the supply blower and exhaust fan(s). The analog control for the VFDs is 0-10VDC. This manual uses percent (%) to indicate blower and fan speeds. For example, 50% blower speed is equal to 30Hz and 5VDC.

Speed %	Motor Frequency (Hz)	VFD Control Voltage (VDC)
0	0	0
10	6	1
20	12	2
30	18	3
40	24	4
50	30	5
60	36	6
70	42	7
80	48	8
90	54	9
100	60	10

Supply Bypass Damper Control

The IMC is only compatible with bypass damper actuators specified in the Engineering Handbook. The actuators control the supply air volume for constant air volume units equipped with a bypass damper (CAVB) in zoning applications. The analog control for the actuator is 2-10VDC. Dampers are closed at 10VDC and fully open at 2VDC. This manual uses percent (%) to indicate bypass damper position. For example, 70% bypass damper position is equal to 4.4VDC.

Bypass Damper Position (%)	Control Voltage (VDC)
0 (closed)	10
10	9.2
20	8.4
30	7.6
40	6.8
50	6.0
60	5.2
70	4.4
80	3.6
90	2.8
100	2.0

Air Delivery Setup For CAV w/Bypass For Changeover Zoning Applications				
ECTO No.	Name	Default Setting	Setting Required	Description
0.01	Supply_VAV_Control_Mode	0	1	Sets PID control of bypass damper for all modes, ventilation, cooling, heating and smoke alarms.
0.10	PID_P_Constant	17	Select (Recommend default)	PID Proportional constant
0.11	PID_I_Constant	12	Select (Recommend default)	PID Integral constant
0.12	PID_D_Constant	0	Select (Recommend default)	PID derivative constant
0.13	CAVB_SMK_SP	1.00 "w.c.	Select 0-5 "w.c.	Supply static pressure setpoint during smoke alarm. Typically 1 to 1.5 "w.c.
0.14	CAVB_Vent_SP	1.00 "w.c.	Select 0-5 "w.c.	Supply static pressure setpoint during ventilation only. Typically 1 to 1.5 "w.c.
0.15	CAVB_HT_SP	1.00 "w.c.	Select 0-5 "w.c.	Supply static pressure setpoint during heating. Typically 1 to 1.5 "w.c.
0.16	CAVB_CL_SP	1.00 "w.c.	Select 0-5 "w.c.	Supply static pressure setpoint during cooling. Typically 1 to 1.5 "w.c.
0.17	CAVB_Min_Output_for SMK_Vent_CL	20%	Select 20-100% (Recommend default)	Minimum output to bypass damper during smoke alarm, ventilation only and cooling. Sets minimum air delivered. Bypass damper motor is set to 10 to 2 volts with 10 v being closed.
0.18	CAVB_Min_Output_for HT	20%	Select 20-100% (Recommend default)	Minimum output to bypass damper during heating. Sets minimum delivered.
0.19	CAVB_Max_Output	100%	Select 20-100% (Recommend default)	Maximum output to bypass damper for all modes. Sets the maximum air delivered.
0.20	CAVB_ManRS	52%	Select 20-100% (Recommend default)	Bypass damper manual reset value output. Output when blower is off.
0.21	Supply_Static_Shutdown_SP	2.0 "w.c.	Select 0-5.0 "w.c.	Supply static shutdown setpoint. Unit will shutdown for ECTO 5.02 minutes if duct pressure exceeds this value for 20 seconds
0.22	Supply_Static_Lockout_Counts	3	Select 0-5 counts (Recommend default)	The number of occurrences before permanent lockout. Counter resets when IMC resets. A value of 0 will disable lockout.
Air Delivery Setup For VAV Zoning Applications				
0.01	Supply_VAV_Control_Mode	0	63	Sets PID control of VFD all modes, ventilation, cooling, heating and smoke alarms.
0.02	VAV_Press_SMK_SP	1.00 "w.c.	Select 0-5 "w.c.	VAV supply static pressure setpoint during smoke detection.
0.03	VAV_Press_Vent_SP	1.00 "w.c.	Select 0-5 "w.c.	VAV supply static pressure setpoint during ventilation.
0.04	VAV_Press_HT_SP	1.00 "w.c.	Select 0-5 "w.c.	VAV supply static pressure setpoint during heating.
0.05	VAV_Press_CL_SP	1.00 "w.c.	Select 0-5 "w.c.	VAV supply static pressure setpoint during cooling.
0.06	VAV_Min_Output_for CL_VT_SMK.	50 %	Select 30-100%	Supply minimum speed for cooling, ventilation or smoke. If minimum is >= manual reset (ECTO 0.09), then manual reset used is shifted to (ECTO 0.07 + ECTO 0.08) / 2
0.07	VAV_Min_Output_for HT	50%	Select 30-100%	Supply minimum speed for heating. If minimum is >= manual reset (ECTO 0.09), then manual reset used is shifted to (ECTO 0.06 + ECTO 0.08) / 2
0.08	VAV_Max_Output	100%	Select 0-100% 0-100%	Supply maximum output.
0.09	VAV_PID_ManRS	60%	Select 0-100% (Recommend default)	Supply PID manual reset value.

Air Delivery Setup For VAV Zoning Applications - continued

ECTO No.	Name	Default Setting	Setting Re-quired	Description
0.10	PID_P_Constant	17	Select (Recommend default)	PID Proportional constant
0.11	PID_I_Constant	12	Select (Recommend default)	PID Integral constant
0.12	PID_D_Constant	0	Select (Recommend default)	PID derivative constant
0.21	Static_Shutdown_SP	2.0 "w.c.	Select 0-5 "w.c.	Supply static shutdown setpoint. Unit will shutdown for ECTO 5.02 minutes if duct pressure exceeds this value for 20 seconds.
0.22	Static_Lock-out_Counts	3	Select 0-3 (Recommend default)	The number of occurrences before permanent lockout. Counter resets when IMC resets. A value of 0 will disable lockout.
Discharge Air Control Setup for Cooling				
5.04	CL_Stg_Option	2	4	Option 4 sets control to operate discharge air control cooling when Y1 is energized.
7.16	DACC_OCP_SP	55F	Select 40-80F	Discharge Air Control Cooling setpoint during occupied period.
7.17	DACC_UnOCP_SP	65F	Select 40-80F	Discharge Air Control Cooling setpoint during unoccupied period.
7.18	DACC_Stg_DB	5F	Select 5-20F	Discharge Air Control Cooling stage deadband.
7.19	DACC_&_FAC_StgUp_Delay	180Sec.	Select 0-900 Sec (Recommend default)	Discharge Air Control Cooling and Fresh Air Cooling stage-up delay.
7.20	DACC_&_FAC_StgDn_Delay	120Sec.	Select 0-600Sec. (Recommend default)	Discharge Air Control Cooling and Fresh Air Cooling stage-down time delay.
7.21	DACC_Stg_Diff	2F	Select 2-20F (Recommend default)	Discharge Air Cooling stage differential.
8.01	DACC_RS_Limit	10F	Select 5-20F (Recommend default)	Discharge Air Control Cooling total reset limit. This limits the total DACC reset allowed.
8.02	DACC_RAT_RS_SP	70F	Select 50-80F	Discharge Air Control Cooling return air reset setpoint
8.03	DACC_RAT_RS_Proportional_Band	10F	Select 1-30F	Discharge Air Control Cooling return air reset proportional band.
8.04	DACC_RAT_RS_Adjust_Band	0F (disabled)	Select 0-30F	Discharge Air Control Cooling return air reset adjustment band. 0 disables return air cooling reset.
8.05	DACC_OAT_RS_SP	80F	Select 40-100F	Discharge Air Control Cooling outdoor air temperature cooling reset setpoint.
8.06	DACC_OAT_RS_Proportional_Band	20F	Select 1-60F	Discharge Air Control Cooling outdoor ambient temperature cooling proportional band.
8.07	DACC_OAT_RS_Adjust_Band	0F (disabled)	Select 0-30F	Discharge Air Control Cooling outdoor temperature ambient cooling adjustment reset band. 0 disables outdoor air cooling reset

Discharge Air Control Setup for Heating				
5.09	HT_Staging	2	1	Option 1 sets control to operate discharge air control heating when W1 is energized.
7.10	DACH_OCP_SP	110	Select 80-140F	Discharge Air Control Heating setpoint during occupied period.
7.11	DACH_UnOCP_SP	100	Select 80-140F	Discharge Air Control Heating setpoint during unoccupied period.
7.12	DACH_Stg_DB	5F	Select 5-20F (Recommend default)	Discharge Air Control Heating deadband.
7.13	DACH_&_FAC_StgUp_Delay	180 Sec.	Select 0-900Sec. (Recommend default)	Discharge Air Control Heating and Fresh Air Heating stage-up time delay.

Discharge Air Control Setup for Heating				
ECTO No.	Name	Default Setting	Setting Required	Description
7.14	DACH_&_FAC_SgDn_Delay	120 Sec.	Select 0-600Sec. (Recommend default)	Discharge Air Control Heating and Fresh Air Heating stage-down time delay.
7.15	DACH_Stg_Diff	2F	Select 2-20F (Recommend default)	Discharge Air Control Heating stage differential
8.08	DACH_RS_Limit	10F	Select 5-20F. (Recommend default)	Discharge Air Control Heating reset limit. This limits the total DACH reset allowed.
8.09	DACH_RAT_RS_RS_SP	70F	Select 50-80F.	Discharge Air Control Heating return air heating reset setpoint.
8.10	DACH_RAT_RS Proportional_Band.	10F	Select 1-30F.	Discharge Air Control Heating return air heating reset proportional band.
8.11	DACH_RAT_RS_Adjust_Band	0F (disabled)	Select 0-30F.	Discharge Air Control Heating return reset adjustment band. 0 value disables return air heating reset.
8.12	DACH_OAT_RS_SP	40F	Select -31-60F.	Discharge Air Control Heating outdoor temperature reset setpoint.
8.13	DACH_OAT_RS Proportional_Band.	20F	Select 1-60F.	Discharge Air Control Heating temperature reset proportional band.
8.14	DACH_OAT_RS_Adjust_Band	0F (disabled)	Select 0-30F.	Discharge Air Control Heating outdoor temperature reset adjustment band. 0 disables outdoor temperature heating reset

Power Exhaust Setup

				Single Stage (Controlled by A56_P115-3 Output)																																				
				<table border="1"> <thead> <tr> <th>Mode</th> <th>Enable</th> <th>Input</th> </tr> </thead> <tbody> <tr><td>0-</td><td>Blower</td><td>D_POS</td></tr> <tr><td>1-</td><td>Always</td><td>A133_P149-1</td></tr> <tr><td>2-</td><td>OCP</td><td>A133_P194-1</td></tr> <tr><td>3-</td><td>Blower</td><td>A133_P194-1</td></tr> <tr><td>4-</td><td>Always</td><td>A133_P194-7</td></tr> <tr><td>5-</td><td>Occupied</td><td>A133_P194-7</td></tr> <tr><td>6-</td><td>Blower</td><td>A133_P194-7</td></tr> <tr><td>7-</td><td>A133_P194-1</td><td>A133_P194-7</td></tr> </tbody> </table>	Mode	Enable	Input	0-	Blower	D_POS	1-	Always	A133_P149-1	2-	OCP	A133_P194-1	3-	Blower	A133_P194-1	4-	Always	A133_P194-7	5-	Occupied	A133_P194-7	6-	Blower	A133_P194-7	7-	A133_P194-1	A133_P194-7									
Mode	Enable	Input																																						
0-	Blower	D_POS																																						
1-	Always	A133_P149-1																																						
2-	OCP	A133_P194-1																																						
3-	Blower	A133_P194-1																																						
4-	Always	A133_P194-7																																						
5-	Occupied	A133_P194-7																																						
6-	Blower	A133_P194-7																																						
7-	A133_P194-1	A133_P194-7																																						
				Two Stage Exhaust Fan (Controlled by A56_P115-3 and A133_P194-5 Outputs)																																				
				<table border="1"> <thead> <tr> <th>Mode</th> <th>Enable</th> <th>Input 1</th> <th>Input 2</th> </tr> </thead> <tbody> <tr><td>8-</td><td>Blower</td><td>D_POS</td><td>D_POS</td></tr> <tr><td>9-</td><td>Always</td><td>A133_P194-1</td><td>A133_P194-2</td></tr> <tr><td>10-</td><td>Occupied</td><td>A133_P194-1</td><td>A133_P194-2</td></tr> <tr><td>11-</td><td>Blower</td><td>A133_P194-1</td><td>A133_P194-2</td></tr> <tr><td>12-</td><td>Always</td><td>A133_P194-7</td><td>A133_P194-7</td></tr> <tr><td>13-</td><td>Occupied</td><td>A133_P194-7</td><td>A133_P194-7</td></tr> <tr><td>14-</td><td>Blower</td><td>A133_P194-7</td><td>A133_P194-7</td></tr> <tr><td>15-</td><td>A133_P194-1</td><td>A133_P194-7</td><td>A133_P194-7</td></tr> </tbody> </table>	Mode	Enable	Input 1	Input 2	8-	Blower	D_POS	D_POS	9-	Always	A133_P194-1	A133_P194-2	10-	Occupied	A133_P194-1	A133_P194-2	11-	Blower	A133_P194-1	A133_P194-2	12-	Always	A133_P194-7	A133_P194-7	13-	Occupied	A133_P194-7	A133_P194-7	14-	Blower	A133_P194-7	A133_P194-7	15-	A133_P194-1	A133_P194-7	A133_P194-7
Mode	Enable	Input 1	Input 2																																					
8-	Blower	D_POS	D_POS																																					
9-	Always	A133_P194-1	A133_P194-2																																					
10-	Occupied	A133_P194-1	A133_P194-2																																					
11-	Blower	A133_P194-1	A133_P194-2																																					
12-	Always	A133_P194-7	A133_P194-7																																					
13-	Occupied	A133_P194-7	A133_P194-7																																					
14-	Blower	A133_P194-7	A133_P194-7																																					
15-	A133_P194-1	A133_P194-7	A133_P194-7																																					
				VFD (PID) controlled Exhaust Fan with on/off cycling at minimum speed (Cycled by A56_P115_3 and Speed controlled by VFD)																																				
				<table border="1"> <thead> <tr> <th>Mode</th> <th>Enable</th> <th>Analog Input</th> </tr> </thead> <tbody> <tr><td>16</td><td>Always</td><td>A133_P194-7</td></tr> <tr><td>17-</td><td>Occupied</td><td>A133_P194-7</td></tr> <tr><td>18-</td><td>Blower</td><td>A133_P194-7</td></tr> <tr><td>19-</td><td>A133_P194-1</td><td>A133_P194-7</td></tr> </tbody> </table>	Mode	Enable	Analog Input	16	Always	A133_P194-7	17-	Occupied	A133_P194-7	18-	Blower	A133_P194-7	19-	A133_P194-1	A133_P194-7																					
Mode	Enable	Analog Input																																						
16	Always	A133_P194-7																																						
17-	Occupied	A133_P194-7																																						
18-	Blower	A133_P194-7																																						
19-	A133_P194-1	A133_P194-7																																						
				VFD (PID) controlled Exhaust Fan (Always on when enabled) (Cycled by A56_P115_3 and Speed controlled by VFD)																																				
				<table border="1"> <thead> <tr> <th>Mode</th> <th>Enable</th> <th>Analog Input</th> </tr> </thead> <tbody> <tr><td>20</td><td>Always</td><td>A133_P194-7</td></tr> <tr><td>21</td><td>Occupied</td><td>A133_P194-7</td></tr> <tr><td>22</td><td>Blower</td><td>A133_P194-7</td></tr> <tr><td>23</td><td>A133_P194-1</td><td>A133_P194-7</td></tr> </tbody> </table>	Mode	Enable	Analog Input	20	Always	A133_P194-7	21	Occupied	A133_P194-7	22	Blower	A133_P194-7	23	A133_P194-1	A133_P194-7																					
Mode	Enable	Analog Input																																						
20	Always	A133_P194-7																																						
21	Occupied	A133_P194-7																																						
22	Blower	A133_P194-7																																						
23	A133_P194-1	A133_P194-7																																						
8.16	Exh_Fan_Control	0	Select depending on type of exhaust fan.	<p>Use ECTO 8.20 and 8.21 for setpoint and deadband. Use ECTO 8.17 for 0-10VDC stage 1 output if A133 (VAV) present.</p> <p>Use ECTO 8.20-8.25 for stage setpoints, deadbands and stage delays. Use ECTO 8.17 for 0-10VDC stage 1 output. Use ECTO 8.18 for 0-10VDC stage 2 output.</p> <p>For option 9-15, Stage 2 will not turn on until ECTO 8.25 seconds after stage 1. Stage 1 won't turn off until ECTO 8.22 seconds after stage turns off.</p> <p>Min. speed cycling: On at 10% over setpoint. Off after 30 seconds at minimum speed. Minimum 30 seconds off.</p> <p>Always on at least minimum speed when enabled.</p>																																				
8.17	Exh_Fan_Stg_1_SP	50%	Select 0-100%	Speed setpoint for stage 1 exhaust fan when using a VFD for controlling exhaust fan in staged mode.																																				
8.18	Exh_Fan_Stg_2_SP	100%	Select 0-100%	Speed setpoint for stage 2 exhaust fan when using a VFD for controlling exhaust fan in staged mode.																																				
8.19	Exh_Fan_SP_for_SMK	-0.3 "w.c.	Select -0.5 – 0.5 "w.c.	Exhaust fan smoke mode setpoint for PID option control																																				
	Staged_SMK	50%	0-100%	Staged setpoint for during smoke alarm. Value used depends on smoke mode (ECTO 5.01)																																				
8.20	Exh_Fan_SP	-0.3 "w.c.	Select -0.5 – 0.5 "w.c.	Exhaust fan setpoint for PID option control																																				
	Stage_1_SP	50%	0-100%	Stage 1 setpoint																																				
8.21	Exh_Fan_Min.	10%	Select 0-100%	Exhaust fan minimum speed																																				
	Staged_1_DB	0.04	0-1.0 "w.c.	Staged 1 deadband.																																				

8.22	Exh_Fan_ManRS	10%	Select 0-100%	Exhaust fan PID loop manual reset value
	Stg_1_Off_Delay	100 Sec.	0-200 Sec.	Stage 1 off-delay.
8.23	Exh_Fan_PID_P_Constant	20Counts	Select 0-255Counts	Exhaust fan PID loop proportional constant
	Stg_2_SP	"w.c.	-0.5 -0.5 "w.c.	Staged 2 setpoint.
8.24	Exh_Fan_PID_I_Constant	64Counts	Select 0-255 Counts	Exhaust fan PID loop integral constant
	Stg_2_DB	.25"w.c.	0-1.0 "w.c.	Staged 2 deadband.
8.25	Exh_Fan_PID_D_Constant	0 Counts	Select 0-127 Counts	Exhaust fan PID loop derivative constant
	Stg_2_On_Delay	0 Sec.	0-254Sec.	Staged 2 on-delay.

IMC BACnet™ Module

The optional IMC BACnet module allows communication between the Lennox IMC (M1-7, version 5.02 and higher) and a BACnet MSTP network. The module translates input and output variables between the Lennox protocol and the BACnet protocol. The BACnet module has been developed to communicate with building automation systems that support the BACnet Application Specific Controller (B-ASC) device profile. A Lennox

non-communicating zone sensor, a BACnet network zone sensor, or a BACnet thermostat may be used to send the zone temperature or thermostat demands to the IMC.

Note - A qualified systems integrator with adequate training and experience is required to integrate and commission the IMC BACnet module into a third-party BACnet building automation system. A BACnet network configuration software tool is required to commission the BACnet network.

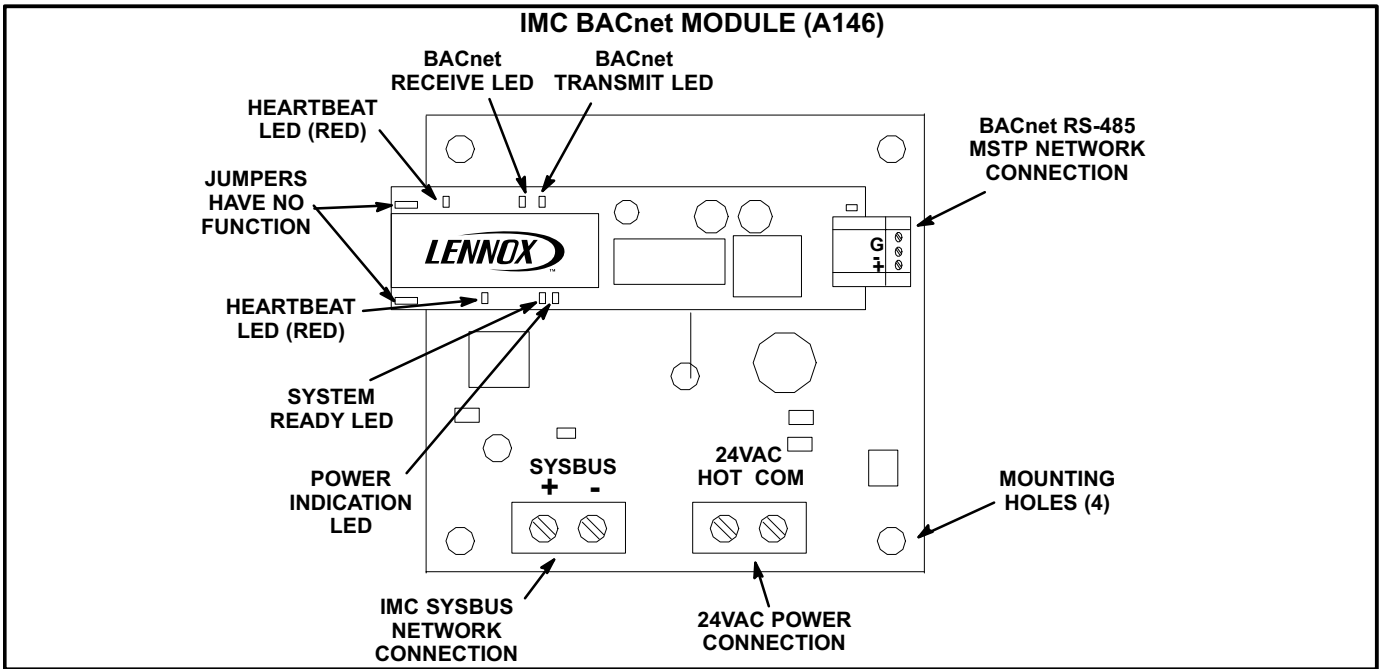

FIGURE 63

The following BACnet datapoints are available:

BACNET INPUTS TO IMC		
BACnet Object Name	Object Type: ID: Units	Description
Application Mode Control	AO: 101:95 (No_Units)	Unit application
0-Auto		Heating or cooling. Default after reset.
1-Heat		Heating only.
3-Cool		Cooling only.
6-Off		Unit off.
9-Fan only		No heating or cooling allowed.
208-Fan auto		Main fan (blower) auto. Default after reset.
209-Fan on		Main fan (blower) on.
216-Exhaust auto		Power exhaust fan auto. Default after reset.
217-Exhaust on		Power exhaust fan on.
218-Exhaust off		Power exhaust fan off.
224-Idle		Heat / cool off. Default after reset.
225-Heat1		Heat 1
226-Heat2		Heat 2. Heat pump emergency heat.
227-Heat3		Heat 3. Full heating.
228-Cool1		Cool 1
229-Reheat lo		Supermarket reheat (lo)
230-Reheat high		Supermarket reheat (hi)
232-Cool2		Cool 2
236-Cool3		Cool 3. Full cooling.
254-Reset		Force controller reset
255-Null		Same as auto.
Outdoor Air Min Pos Control	AO: 102 : 98 (Percent)	Min economizer damper position
Occupancy Override Control	AO: 103: 95 (No_Units)	Zone occupied status
Occupancy Scheduler Control	AO: 104: 95 (No_Units)	Occupancy scheduler input used to put controller unit into different occupancy modes.
Occupancy Sensor Input	AO: 107: 95 (No_Units)	Occupancy sensor input. Used to indicate the presence of occupants
Space Dehumidification Setpt	AO: 108: 98 (Percent)	Zone relative humidity set point
Temperature Setpoint (abs)	AO: 109: 64 (Degrees - Fahrenheit)	Zone temperature setpoint
Temperature Setpoint Offset	AO: 110: 64 (Degrees - Fahrenheit)	Zone temp setpoint offset
Space Temperature Input	AO: 113: 64 (Degrees - Fahrenheit)	Remote zone temp.
Emergency Override Control	AO: 114: 95 (No_Units)	Emergency smoke override
Compressor Enable Control	AO: 115: 98 (Percent)	Compressor enable
Primary Heat Enable Control	AO: 117: 98 (Percent)	Primary heat enable
Auxiliary Heat Enable Control	AO: 119: 98 (Percent)	Auxiliary heat enable

BACNET OUTPUTS FROM IMC		
IMC Version [00].....[07]	AI: 200-207 : 95 (No_Units)	IMC firmware version. (null terminated ASCII)
Unit ID	AI: 231 : 95 (No_Units)	Unit ID \$3x-Gas/Elect. \$4x-Elect/Elect. \$5x-Heat Pump
Unit Status	AI :232 : 95 (No_Units)	Unit operation mode (i.e. cool, heat, etc.)
1 - HVAC heat		
2 - HVAC morning warm-up		
3 - HVAC cool		
5 - HVAC pre-cool		
6 - HVAC off		
7 - HVAC test		
8 - HVAC emergency heat		
9 - HVAC fan only		
12 - HVAC max heat		
14 - HVAC dehumidification		
129 - HVAC fresh air heating		
131 - HVAC fresh air cooling		
145 - HVAC defrost 1		
161 - HVAC defrost 2		
177 - HVAC defrost 1, 2		
Space Temperature	AI: 239 : 64 (Degrees - Fahrenheit)	
Discharge Air Temperature	AI: 240 : 64 (Degrees - Fahrenheit)	Supply air temperature
Effective Occupancy	AI: 241 : 95 (No_Units)	Zone occupied status
Local Outside Air Temperature	AI: 242 : 64 (Degrees - Fahrenheit)	Outdoor air temperature
Local Space Temperature	AI: 243 : 64 (Degrees Fahrenheit)	Zone Temperature, local
Outside Air Damper	AI: 244 : 98 (Percent)	Economizer damper position
Heat Primary	AI: 245 : 98 (Percent)	Primary heating status
Heat Secondary	AI: 246 : 98 (Percent)	Heat pump electric strip heating status
Cool Primary	AI: 247 : 98 (Percent)	Cooling compressor 1-4 status (on/off)
Economizer Enabled	AI: 248 : 95 (No_Units)	Economizer outdoor air suitable
Supply Fan Status	AI: 250 : 98 (Percent)	Supply fan status
Space Temperature Set Point (Eff)	AI: 252 : 64 (Degrees Fahrenheit)	Zone temperature set points
Current Error	AI: 253 : 95 (No_Units)	Currently displayed error code
Error Pointer	AI: 254 : 95 (No_Units)	Error pointer. This value points to the next available alarm code location. It runs from 0 to 83 and then rolls-over to 0. Tracking this value and using the ten most recent error codes (below) allows an application to determine when new errors are logged by the IMC, what those errors are, and if any errors have been missed due to network delays or for any other reason.

BACNET OUTPUTS FROM IMC		
Most recent Error 1..10	AI: 255-264 : 95 (No _Units)	IMC alarm codes as listed in the IMC manual.
Space CO2 Sensor (Local)	AI : 274 :96 (Parts per million)	Zone CO ₂ level (PPM), local
Space Humidity (Local)	AI: 276 : 98 (Percent)	Zone relative humidity, local
Dehumidification Set Point (Eff)	AI: 278 : 98 (Percent)	Zone relative humidity set point
Dehumidification Status	AI: 279 : 95 (No_Units)	Dehumidification status
Return Air Temperature	AI: 281 :64 (Degrees Fahrenheit))	Return air temperature
Building Static Pressure	AI: 282 : 64 (Inches of water)	Analog Input 2 (GP1 - VAV Bldg. Static)
Duct Static Pressure	AI: 282 : 64 (Inches of water)	Analog Input 1 (GP1 - VAV Supply Stat-ic)
Exhaust Fan Status	AI: 285 :98 (Percent)	Exhaust fan status
Controller Online	BI:100 :95 (No_Units)	IMC Communicating

IMC LonTalk® Module

The optional IMC LonTalk module allows communication between the Lennox IMC (M1-7, version 5.02 and higher) and a LonWorks® network. The module translates input and output variables between the Lennox protocol and the LonTalk protocol. The IMC LonTalk module has been developed to communicate with building automation systems that support the LonMark® Space Comfort Control (SCC) or Discharge Air Control (DAC) functional profiles. A Lennox non-communicating zone sensor, a LonTalk network

zone sensor, or a LonTalk thermostat may be used to send the zone temperature or thermostat demands to the IMC.

Note - A qualified systems integrator with adequate training and experience is required to integrate and commission the IMC LonTalk module into a third-party LonTalk building automation system. A LonWorks network configuration software tool such as LonMaker® (or equivalent) is required to commission the LonWorks network. An external interface file (XIF) will be made available upon request.

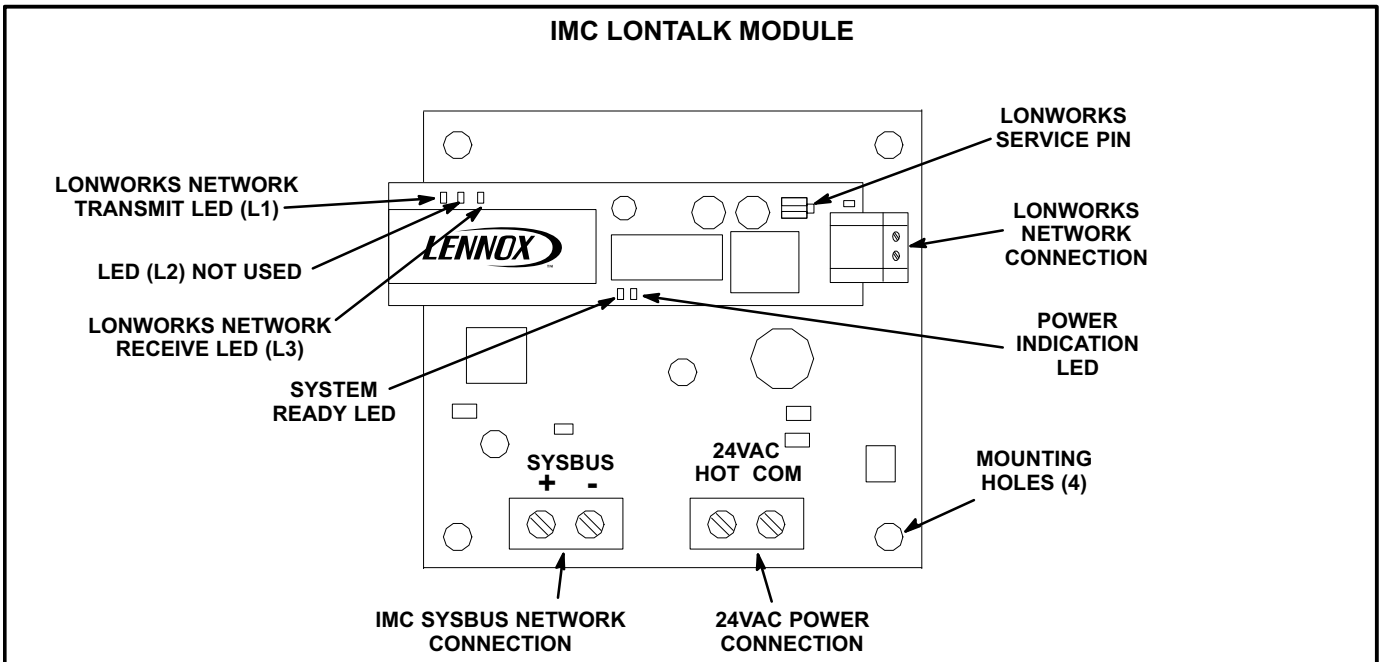

FIGURE 64

The following LonTalk datapoints are available:

LONTALK INPUTS TO IMC		
LonMark Name	Variable Type	Description
nviApplicMode	SNVT_hvac_status	Unit application mode
0-Auto		Heating or cooling. Default after reset.
1-Heat		Heating only.
3-Cool		Cooling only.
6-Off		Unit off.
9-Fan only		No heating or cooling allowed.
208-Fan auto		Main fan (blower) auto. Default after reset.
209-Fan on		Main fan (blower) on
216-Exhaust auto		Power exhaust fan auto. Default after reset.
217-Exhaust on		Power exhaust fan on.
218-Exhaust off		Power exhaust fan off.
224-Idle		Heat / cool off. Default after reset.
225-Heat1		Heat 1
226-Heat2		Heat 2. Heat pump emergency heat.
227-Heat3		Heat 3. Full heating.
228-Cool1		Cool 1
229-Reheat lo		Supermarket reheat (lo)
230-Reheat high		Supermarket reheat (hi)
232-Cool2		Cool 2
236-Cool3		Cool 3. Full cooling.
254-Reset		Force controller reset
255-Null	Same as auto.	
nviOAMinPos	SNVT_lev_percent	Min economizer damper position
nviOccManCmd	SNVT_occupancy	Zone occupied status
nviOccSchedule	SNVT_tod_event	Occupancy scheduler input used to put controller unit into different occupancy modes
nviOccSensor	SNVT_occupancy	Occupancy sensor input. Used to indicate the presence of occupants
nviSpaceDehumSP	SNVT_lev_percent	Zone relative humidity set point
nviSetpoint	SNVT_temp_p	Zone temperature setpoint
nviSetptOffset	SNVT_temp_p	Zone temp setpoint offset
nviSpaceTemp	SNVT_temp_p	Remote zone temp.
nviEmergOverride	SNVT_hvac_emerg	Emergency smoke override
nviComprEnable	SNVT_switch	Compressor enable
nviPriHeatEnable	SNVT_switch	Primary heat enable
nviAuxHeatEnable	SNVT_switch	Auxiliary heat enable

LONTALK OUTPUTS TO IMC

LonMark Name	Variable Type	Description
snvoIMCVersion	Manufacturer defined	IMC firmware version. D0-D3 (ASCII)
snvoUnitID	Manufacturer defined	Unit ID. \$3x-Gas/Elect \$4x-Elect/Elect \$5x-Heat Pump
nvoUnitStatus:	SNVT_hvac_status	Unit operation mode (i.e. cool, heat, etc)
1 - HVAC heat		
2 - HVAC morning warmup		
3 - HVAC cool		
5 - HVAC pre-cool		
6 - HVAC off		
7 - HVAC test		
8 - HVAC emergency heat		
9 - HVAC fan only		
12 - HVAC max heat		
14 - HVAC dehumidification		
129 - HVAC fresh air heating		
131 - HVAC fresh air cooling		
145 - HVAC defrost 1		
161 - HVAC defrost 2		
177 - HVAC defrost 1 2		
nvoSpaceTemp	SNVT_temp_p	Zone Temperature, effective
nvoDischAirTemp	SNVT_temp_p	Supply air temperature
nvoEffectOccup	SNVT_occupancy	Zone occupied status
nvoLocalOATemp	SNVT_temp_p	Outdoor air temperature
nvoLocalSpaceTemp	SNVT_temp_p	Zone Temperature, local
nvoOADamper	SNVT_lev_percent	Economizer damper position
nvoHeatPrimary	SNVT_lev_percent	Primary heating status
nvoHeatSecondary	SNVT_lev_percent	Heat pump electric strip heating status
nvoCoolPrimary	SNVT_lev_percent	Cooling compressor 1-4 status (on/off)
nvoEconEnabled	SNVT_switch	Economizer outdoor air suitable
nvoSupFanStatus	SNVT_switch	Supply fan status
nvoEffectSetpt	SNVT_temp_p	Zone temperature set points
snvoCurrentError	Manufacturer defined	Currently displayed error code
snvoCommStatus	Manufacturer defined	IMC Communicating

LONTALK OUTPUTS TO IMC

snvoErrorPointer	Manufacturer defined	Error pointer. This value points to the next available alarm code location. It runs from 0 to 83 and then returns to 0. Tracking this value and using the ten most recent IMC error codes (next variable) allows an application to 1) determine when new errors are logged by the IMC, 2) what those errors are, and 3) if any errors have been missed due to network delays or other reasons.
snvoMostRecErr1-10	Manufacturer defined	Alarm codes listed in the IMC manual
nvoSpaceCO2	SNVT_ppm	Zone CO2 level (PPM), local
nvoSpaceRHEff	SNVT_lev_percent	Zone relative humidity, effective
nvoSpaceRH	SNVT_lev_percent	Zone relative humidity, local
nvoEffSpaceDHSP	SNVT_lev_percent	Zone relative humidity set point
nvoDehumidifier	SNVT_switch	Dehumidification status
nvoRATemp	SNVT_temp_p	Return air temperature
nvoBldgStatPress	SNVT_press_p	Analog Input 2 (GP1 - VAV Bldg Static)
nvoDuctStatPress	SNVT_press_p	Analog Input 1 (GP1 - VAV Supply Static)
nvoExhFanStatus	SNVT_switch	Exhaust fan status

Electronic Configure To Order (ECTO) Control Parameters

Many IMC main control operations may be varied within a set range. Default settings are based on common or average applications; change ECTO settings only when custom applications, preferences or local building codes exist. Default, minimum, and maximum range settings are found in table 48.

ECTO parameters may be changed three different ways:

- M1-7 Board Pushbutton and Display
- Optional PC with PC Converter and UC Software

M1-7 (A55) PUSHBUTTON AND DISPLAY

Reading Parameters

Control parameters can be viewed using the pushbutton and display. Set the MODE DIP "ECTO" to "ON" to read the parameter which corresponds to a control value. See figure 65.

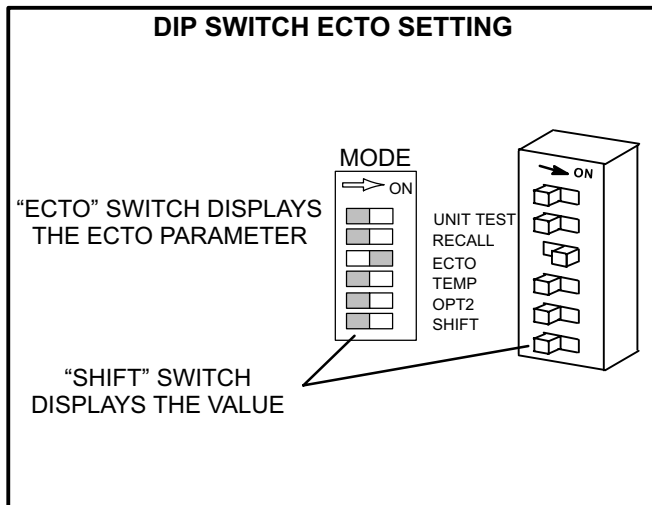

FIGURE 65

The parameters are set up in ten different blocks or groups. The first digit of each parameter indicates the block as follows:

- 0-VAV/CAVB
- 1-Heat Pump Heating
- 2-Electric Heating
- 3-Gas Heating
- 4-Cooling
- 5-Miscellaneous
- 6-System 1
- 7-System 2
- 8-System 3
- 9-GP Board

A short push will move the display to the next parameter. A double push will move the display to the previous parameter. A long push will move the reading to the next block.

An M1 board with DIP switches set for a gas heating unit will skip heat pump block 1 and electric heating block 2

readouts. An M1 board with DIP switches set for an electric heating unit will skip heat pump block 1 and gas heating block 3 readouts. An M1 board with DIP switches set for a heat pump unit will skip electric heating block 2 and gas heating block 3 readouts.

Changing Control Values

Control values may be adjusted using the pushbutton and display. Once the appropriate control parameter is displayed, turn on the MODE DIP "SHIFT" to read the current ECTO value. See figure 65.

A short push will display the next value. A double push will decrease the value by 10. A long push before returning to control parameters (turning off SHIFT switch) will return the value to the currently stored value. A long push will move the reading to the next block and store the new ECTO value. The value may also be stored by turning off the SHIFT DIP switch, waiting for the parameter number to reappear, and turning off the ECTO DIP switch. The readout will turn off and all decimals will turn on when new ECTO parameters are stored. The control also resets at this time.

Control parameters are displayed in codes or number of counts. See table 49 to determine actual time or temperature span. Use table 50 to convert counts to value and value to counts.

Change ECTO Summary:

- 1-Turn ECTO switch on.
- 2-Pushbutton to desired parameter.
Short push advances parameter.
Long push advances block.
- 3-Read present ECTO value with SHIFT switch.
- 4-Single push increases the value by 1; double push decreases the value by 10.
- 5-Turn off SHIFT switch. For multiple changes repeat steps 2 through 5.
- 6-Wait for the parameter number to reappear.
Turn off ECTO switch.

Example:

Use the following steps to increase compressor minimum-off delay interval.

- 1- Set the MODE DIP "ECTO" to "ON".
- 2- With a long push on the pushbutton, move the control parameter to the cooling block; the display will read "4.01".
- 3- With short pushes of the pushbutton, toggle upward until the readout displays "4.12".
- 4- Set the MODE DIP "SHIFT" to "ON".
- 5- The display will read "150.". The ECTO Control Parameter Table (Table 48) shows a default of 150 counts or 300 seconds. The table also shows a range of 30 counts (60 seconds) to 255 counts (510 seconds).

- 6- To change the compressor minimum-off delay from 300 seconds (5 minutes) to 360 seconds (6 minutes), refer to Code Conversion Table (Table 49 Column A) as shown in Control Parameter Table (Table 48) for number of counts to adjust control value to.
- 7- Short push the pushbutton until readout displays "180".
- 8- To store the new ECTO control parameter, turn off the SHIFT switch. Wait for the parameter number to reappear. Turn off the ECTO switch. The readout will turn off and decimals will turn on. The control resets when new ECTO parameters are stored ("8.8.8." readout will flash).

Reset to factory ECTO parameters

To replace the factory ECTO parameters:

- 1-Turn on the SHIFT DIP switch.
- 2-Turn on the ECTO DIP switch.
- 3-The display will read "---."
- 4- Hold down the pushbutton for approximately five seconds.
- 5-The display will read alternating bright and dim "0" during the transfer. When reset is complete, the display will read a bright "0".
- 6-Turn off ECTO and SHIFT DIP switches. The M1 will automatically reset.

UNIT CONTROLLER PC SOFTWARE

The L Connection Unit Controller PC software is recommended when adjusting multiple ECTO parameters. Unit Controller PC software allows the user to adjust parameters using real units (no conversion from display readout). PC software is faster than using the pushbutton/display interface on the M1 board.

In addition, the PC software allows the user to save unit configuration files. The saved file can be used to apply the same settings to other units.

The Unit Controller software can directly access a unit by plugging into the M1 board phone jack and connecting to a serial port using a PC converter. Any unit on the same daisy-chained network can be adjusted from any unit M1 board or the NCP.

A LAN ethernet converter and phone modem are also available for remote connections.

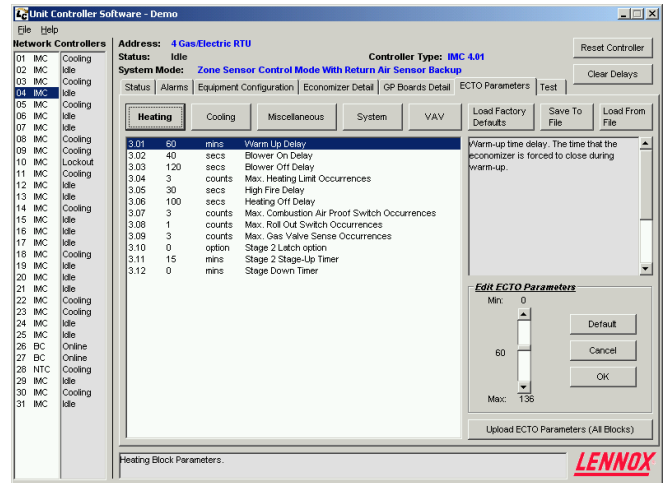

NETWORKING THE IMC CONTROLLERS

A Network Control Panel (NCP) and NCP PC software can be used to schedule building operation for any IMC controller on the same daisy-chained L Connection network.

The Network Thermostat Control (NTC) is an L Connection direct digital controller used on units which are not equipped with an IMC. The Building Controller (BC) is used to control building functions such as lights and signs. Use L Connection specific network cable and daisy chain as shown in figure 66.

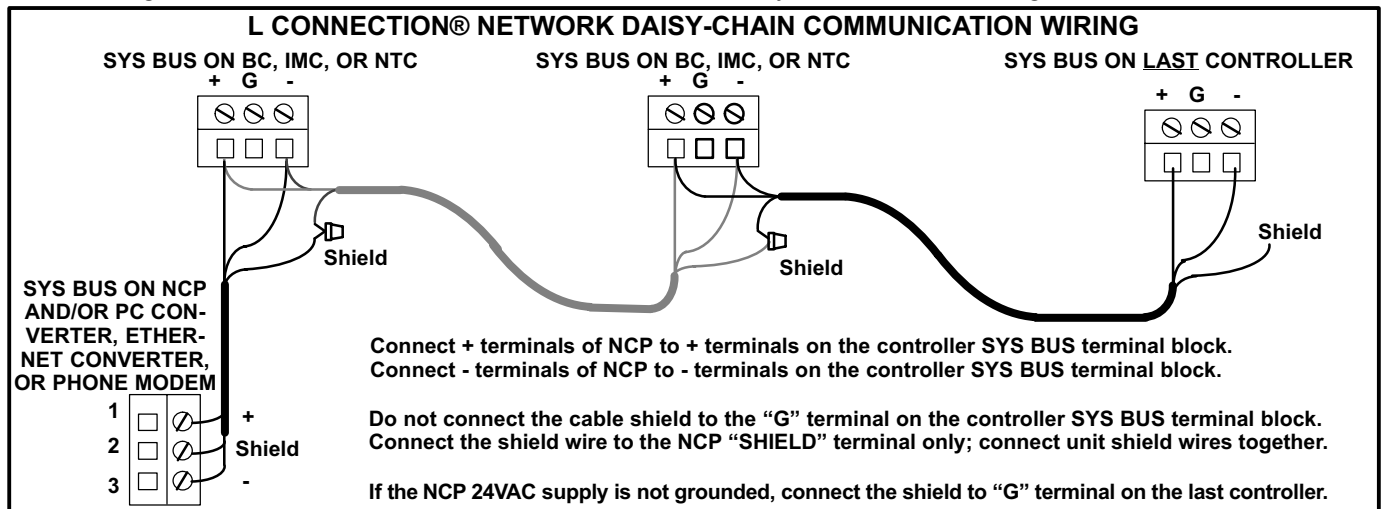

FIGURE 66

Up to 31 controllers can be daisy chained on a single L Connection network. Any combination of IMC, NTC, and BC controller can be used. See figure 67.

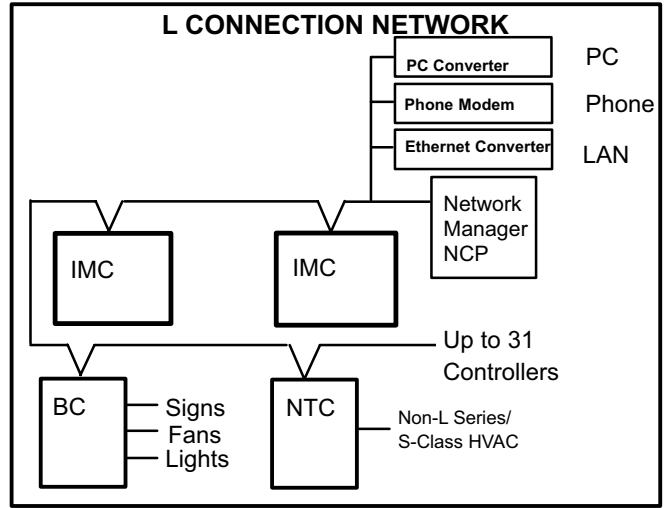

FIGURE 67

TABLE 48
M1 ECTO CONTROL PARAMETERS

BLOCK 0 VAV CAVB PARAMETERS						
Control Parameter		Control Value			Units	Description
No.	Name	Min	Default	Max.		
0.01	Supply_VAV_Control_Mode	0	0	63	Option	<p>Add the weights for each control description to determine option.</p> <p>Weight- Description</p> <p>1- GP1 board present, DIP set to VAV mode for VAV or CAVB control action.</p> <p>2- VAV control action. 0 for CAVB control action. See table 15.</p> <p>The following weights are used for VAV:</p> <p>4- PID control when smoke detected. 0 for staged</p> <p>8- PID control when running ventilation. 0 for staged.</p> <p>16- PID control when running cooling. 0 for staged.</p> <p>32- PID control when running heating. 0 for staged</p> <p>For VAV control action, either PID or staged control can be selected. For CAVB control action, PID is automatically used. (Staged is not available for CAVB). Configuration alarm will occur if GP board (W/DIP set to VAV) is installed and at least one of the following ECTO parameters value are not set to non-zero: ECTO 0.01, 0.23 or 8.16</p>
0.02	VAV_Press_SMK_SP	0	51	255	Counts	VAV supply static pressure setpoint during smoke detection.
	VAV_SMK_Stg_Output	0	1.00	5.0	N:"w.c.	
0.03	VAV_Press_Vent_SP	0	51	255	Counts	VAV supply static pressure setpoint during ventilation.
	VAV_VT_Stg_Output	0	1.00	5.0	N:"w.c.	
0.04	VAV_Press_HT_SP	0	51	255	Counts	VAV supply static pressure setpoint during heating.
	VAV_HT_Stg_Output	0	1.00	5.0	N:"w.c.	
0.05	VAV_Press_CL_SP	0	51	255	Counts	VAV supply static pressure setpoint during cooling.
	VAV_CL_Stg_1_Output	0	1.00	5.0	N:"w.c.	
0.06	VAV_Min_Output_for_CL_VT_SMK	30	50	100	Counts	VAV supply minimum output for cooling, ventilation or smoke.
		30	50	100	P:%	If minimum is >= manual reset (ECTO 0.09), then manual reset used is shifted to (ECTO 0.06 + ECTO 0.08) / 2



ECTO

BLOCK 0 VAV CAVB PARAMETERS

Control Parameter		Control Value			Units	Description
No.	Name	Min	Default	Max.		
0.07	VAV_Min_Output_for_HT	30 30	50 50	100 100	Counts P:%	VAV supply minimum output for heating. If minimum is >= manual reset (ECTO 0.09), then manual reset used is shifted to (ECTO 0.07 + ECTO 0.08) / 2
0.08	VAV_Max_Output	40 40	100 100	100 100	Counts P:%	VAV supply maximum output.
0.09	VAV_PID_ManRS	0 0	60 60	100 100	Counts P:%	VAV supply PID manual reset value. If minimum output, ECTO 0.06 or 0.07 is greater, a computed ManRS value is used. See ECTO 0.06 and 0.07.
0.10	PID_P_Constant	0	17	127	Counts	VAV or CAVB supply PID Proportional constant.
0.11	PID_I_Constant	0	12	127	Counts	VAV or CAVB supply PID Integral constant.
0.12	PID_D_Constant	0	0	127	Counts	VAV or CAVB supply PID derivative constant.
0.13	CAVB_SMK_SP	0 0	51 1.00	255 5.0	Counts N:"w.c.	Constant air volume with bypass damper static pressure setpoint during smoke alarm.
0.14	CAVB_VT_SP	0 0	51 1.00	255 5.0	Counts N:"w.c.	Constant air volume with bypass damper static pressure setpoint for ventilation.
	VAV_CL_Stg_2_Output	0	51	100	P:%	VAV staged % output during cooling 2.
0.15	CAVB_HT_SP	0 0	51 1.00	255 5.0	Counts N:"w.c.	Constant air volume with bypass damper static pressure setpoint for heating
	VAV_CL_Stg_3_Output	0	51	100	P:%	VAV staged % output during cooling 3.
0.16	CAVB_CL_SP	0 0	51 1.00	255 5.0	Counts N:"w.c.	Constant air volume with bypass damper static pressure setpoint for cooling
	VAV_CL_Stg_4_Output	0	51	100	P:%	VAV staged % output during cooling 4.
0.17	CAVB_Min_Output_for_CL_VT_SMK	20 20	20 20	100 100	Counts P:%	Constant air volume with bypass damper minimum output for cooling, ventilation and during smoke alarms. This sets the minimum air delivered. Bypass damper motor is set to 10 to 2 volts with 10 v being closed.
0.18	CAVB_Min_Output_for_HT	20 20	20 20	100 100	Counts P:%	Constant air volume with bypass damper minimum output for heating. This sets the minimum air delivered. Bypass damper motor is set to 10 to 2 volts with 10 v being closed.
0.19	CAVB_Max_output	40 40	100 100	100 100	Counts P:%	Constant air volume with bypass damper maximum output. This sets the maximum air delivered. Bypass damper motor is set to 10 to 2 volts with 10 v being closed.
0.20	CAVB_ManRS	20 20	52 52	100 100	Counts P:%	Constant air volume with bypass damper manual reset value output. This is the output when unit is off.
0.21	Static_Shutdown_SP	0 0	102 2.0	255 5.0	Counts N:"w.c.	Supply static shutdown setpoint. Unit will shutdown for ECTO 5.02 minutes if duct pressure exceeds this value for 20 seconds.
0.22	Static_Lockout_Counts	0	3	8	Counts	The number of occurrences before permanent lockout. Counter resets when IMC resets. A value of 0 will disable lockout.

ECTO

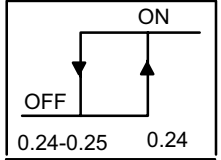
BLOCK 0 VAV CAVB PARAMETERS

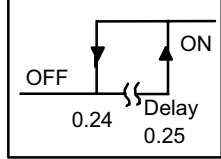
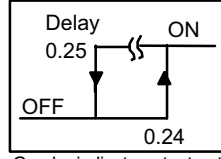
Control Parameter		Control Value			Units	Description
No.	Name	Min	Default	Max.		
0.23	DO_Mode_ A133_(VAV mode)	0	0	127	Option	<p>A133 (w/DIP set to VAV) Digital Out Mode = X + 32*Y + 16*Z Input source= X:</p> <p>0- None. Output enables exhaust fan stage 2. 1- Compressor 1 duty cycle. (Compressor crankcase heater function.) On when OAT <= ECTO 0.24 and >= ECTO 0.25 seconds have passed with compressor 1 off. Off when OAT > ECTO 0.24 + 3 deg F (fixed deadband) or < ECTO 0.25 sec have passed with compressor 1 off. 2- On when occupied. 3- On when blower on. 4- On when heating demand. 5- On when cooling demand. 6.-On when heating or cooling demand. 7- System RH (Either A55_ P114-10 or network RH). 8- System IAQ. (Either A55_ P114-12 or network IAQ). 9- System OAT (Either A55_ P114-13/14 or network OAT). 10-AI1. (A133_P194-6) (SP and DB set with ECTO 0.24 & 0.25). 11-AI2. (A133_P194-7) (SP and DB set with ECTO 0.24 & 0.25). 12-AI3. (A133_P194-8) (SP and DB set with ECTO 0.24 & 0.25). 13-AI4. (A133_P194-9) (SP and DB set with ECTO 0.24 & 0.25). 14-AO1. (A133_P194-11). 15-AO2. (A133_P194-12).</p> <p>Algorithm Y for input sources 7-15: 0 – Hysteresis loop On when input >= ECTO 0.24 Off when input < ECTO 0.24-ECTO 0.25</p>  <p>1—Window On when input is in range; >= ECTO 0.24 and <= ECTO 0.24 + ECTO 0.25 (Fixed 3-count hysteresis loop on rising and falling edges of window.)</p>  <p>2 - Delayed-on. On when input is >= ECTO 0.24 for >= ECTO 0.25 seconds. Off when input is < ECTO 0.24 - 3. (Fixed 3-count hysteresis loop on edge.)</p>  <p>3 - Delayed-off. On when input is >= ECTO 0.24. Off when input is < ECTO 0.24 - 3 for >= ECTO 0.25 seconds. (Fixed 3-count hysteresis loop on edge.)</p>  <p>Inversion Z: 0 - Output not inverted. 1 - Output inverted.</p> <p>Graphs indicate output not inverted. See figure 48.</p>
0.24	DO_SP_ A133_ (VAV mode)	0 0 0 0 132 -.05 0	127 5.0 996 100 51 0 2.5	255 10.0 2000 100 -31 0.5 5.0	Counts R:Volts I:ppm P:% Y:DegF M:"w.c. N:"w.c.	A133 (w/DIP set to VAV) digital output mode setpoint

ECTO

BLOCK 0 VAV CAVB PARAMETERS						
Control Parameter		Control Value			Units	Description
No.	Name	Min	Default	Max.		
0.25	DO_DB_A133 _ (VAV mode)	2	13	255	Counts	A133 (w/DIP set to VAV) digital output mode deadband or delay.
		0	.50	10.0	R:Volts	
		16	102	2000	I:ppm	
		2	13	100	P:%	
		1	8	162	O:DegF	
		64	416	8160	D:Sec.	
		0.01	0.05	1.0	L:"w.c.	
		0	.25	5.0	N:"w.c.	
0.26	Supply_Static-Sensor_Low_Alarm_Check	30	40	101	Count	Supply Static Pressure Sensor (A30) connected at (A133_P195_6) (TB18_6) alarm threshold. Blower percent speed before checking sensor after a 20 second delay. A value of 101 disables the low threshold or "open" alarm trap.
		30	40	101	P:%	
BLOCK 1 HEAT PUMP HEATING PARAMETERS						
Control Parameter		Control Value			Units	Description
No.	Name	Min	Default	Max.		
1.01	WmUp_Delay	28	56	255	Counts	Warm-up time delay. The time that the supplemental heat is held off during the first demand of warm-up. This parameter is only used if the parameter 1.17 is set to option 1.
		896	1792	8160	D:Sec.	
1.02	BL_On_Delay	0	0	15	Counts	Blower on delay. The time before the blower turns on after a heating demand.
		0	0	60	B:Secs	
1.03	BL_Off_Delay	0	5	75	Counts	Blower off delay. The time the blower stays on after the heating demand is lost
		0	20	300	B:Secs	
1.04	Max_HT_LT_Occurrences	1	5	15	Counts	Service output activation. Maximum Primary and Secondary Limit occurrences stored before service relay is energized. If max value is set, service output is disabled. Note: Heating stage is not locked out.
1.05	Sup_HT_Stg_Delay	3	3	15	Counts	Time delay between 1 & 2 stage of supplemental heat.
		12	12	60	B:Secs	
1.06	Sup_HT_2_Lockout_Temp.	113	160	175	Counts	Temperature setpoint for lockout for the second bank of supplemental heat. Note: Temperature must be < or = to ECTO 1.07.
		60	30	20	Y:DegF	
1.07	Sup_HT_1_Lockout_Temp.	113	144	175	Counts	Temperature setpoint for lockout of first bank of supplemental heat. Note: Temperature must be = to or > ECTO1.06.
		60	40	20	Y: Deg.	
1.08	Compr_1_Low_Temp_Lockout	81	255	254	Counts	Low ambient lockout for compressor 1. 254 value equals -30 oF (-34oC). A value of 255 (-31°F) will disable low ambient lockout function. Note: This lockout is for heating only. Temperature must be < or = 1.09.
		80	-31	-30	Y: Deg.	
1.09	Compr_2_Low_Temp_Lockout	81	255	254	Counts	Low ambient lockout for compressor 2. 254 value equals -30 oF (-34oC). A value of 255 (-31°F) will disable low ambient lockout function. Note: This lockout is for heating only. Temperature must be > or = 1.08.
		80	-31	-30	Y: Deg.	
1.10	Compr_Min_Off_Delay	30	150	255	Counts	Compressor minimum off delay. Used on 1 PH units. Also used on all units after an alarm occurs.
		60	300	510	A:Sec	
1.11	Compr_Min_Run_Time	30	120	255	Counts	Compressor minimum run time. Used on 3 PH units.
		60	240	510	A:Sec	
1.12	Max_HP_Occurrences	1	3	8	Counts	Maximum High Pressure occurrences stored before control locks off compressor stage and energizes the service output. If max value is set, lock-out and service output features are disabled.
1.13	Max_LP_Occurrences	1	3	8	Counts	Maximum Low Pressure occurrences stored before control locks off compressor stage and energizes the service output. If max value is set, lock-out and service output features are disabled.
1.14	Defrost_Sup_HT_Option	0	1	1	Option	Defrost options: 0: No supplemental heating during defrost. 1: Supplemental heating on during defrost.
1.15	Min_Time_Between_Defrost	1	2	3	Option	Minimum time allowed between defrost cycles.
						1= 32 minutes
1.16	Max_Defrost_Time	2	3	5	Counts	Maximum defrost time allowed.
		10	15	25	Min	

BLOCK 1 HEAT PUMP HEATING PARAMETERS

Control Parameter		Control Value			Units	Description
No.	Name	Min	Default	Max.		
1.17	WmUp_Option	0	0	2	Option	Warm-up mode option. 0- Supplemental heat may be used during warm-up. Use depends on outdoor temperature. See ECTO 1.06 and 1.07. 1- For the first demand cycle, lockout supplemental heat for the first 30 minutes (default). Time is adjustable by changing the parameter WARM-UP DLY # 1.01. 2- For future use.
1.18	Sup_HT_1_Diff	0 0	8 2	15 3.75	Counts W:DegF	Supplemental heat stage 1 differential. Used in zone sensor applications. Note: Differential temperature must be = to or < ECTO 1.19.
1.19	Sup_HT_2_Diff	0 0	12 3	15 3.75	Counts W:DegF	Supplemental heat stage 2 differential. Used in zone sensor applications. Note: Differential temperature must be = to or > ECTO 1.18
1.20	Sup_HT_1_Latch_Option	0	0	1	Option	Supplemental heat stage 1 latch option. Used in zone sensor applications. 0: Latch Disabled 1: Latch Enabled
1.21	Sup_HT_2_Latch_Option	0	0	1	Option	Supplemental heat stage 2 latch option. Used in zone sensor applications. 0: Latch Disabled 1: Latch Enabled
1.22	Sup_HT_1_StgUp_Timer	0 0	0 0	225 3600	Counts F:Sec	Supplemental heat stage 1 stage-up timer. The maximum time that stage 1 runs before calling supplemental heat stage 1. Used in zone sensor applications. Disabled if set to 0.
1.23	Sup_HT_2_StgUp_Timer	0 0	0 0	225 3600	Counts F:Sec.	Supplemental heat stage 2 stage-up timer. The maximum time that supplemental heat 1 runs before calling supplemental heat stage 2. Used in zone sensor applications. Disabled if set to 0.
1.24	StgDn_Timer	0 0	19 304	225 3600	Counts F:Sec	Time delay before a lower stage turns off following a higher stage termination. Used in zone sensor applications.

BLOCK 2 ELECTRIC HEATING PARAMETERS

Control Parameter		Control Value			Units	Description
No.	Name	Min	Default	Max.		
2.01	WmUp_Delay	0 0	112 3584	255 8160	Counts D:Sec	Warm-up time delay. The time that the economizer is forced closed during warm-up (first occupied +heat demand)
2.02	BL_On_Delay	0 0	0 0	0 0	Counts B:Secs	Blower on delay. The time before the blower turns on after a heating demand. Reserved for future use
2.03	BL_Off_Delay	0 0	5 20	75 300	Counts B:Secs	Blower off delay. The time the blower stays on after the heating demand is lost.
2.04	Max_HT_LT_Occurrences	1	3	15	Counts	Service output activation. Maximum Primary and Secondary Limit occurrences stored before service relay is energized. If max value is set, service output is disabled. Note: Heating stage is not locked out
2.05	HT_Stg_Delay	3 12	3 12	15 60	Counts B:Secs	Time delay between heat stages.
2.06	Stg_Latch_Option	0	0	1	Option	Stage latch option. Used in zone sensor applications. 0: Latch Disabled 1: Latch Enabled
2.07	StgUp_Timer	0 0	57 912	225 3600	Counts F:Sec	Stage up timer. The maximum time that lower stage runs before calling next heat stage. Used in zone sensor applications. Disabled if set to 0.
2.08	StgDn_Timer	0 0	0 0	225 3600	Counts F: Sec	Time delay before a lower stage turns off following a higher stage termination. Used in zone sensor applications.

ECTO

BLOCK 3 GAS HEATING PARAMETERS						
Control Parameter		Control Value			Units	Description
No.	Name	Min	Default	Max.		
3.01	WmUp_Delay	0 0	112 3584	255 8160	Counts D: Sec.	Warm-up time delay. The time that the economizer is forced closed during warm-up (first occupied + heat demand) .
3.02	BL_On_Delay	2 8	10 40	15 60	Counts B: Sec.	Blower on delay. The time before the blower turns on after a heating demand.
3.03	BL_Off_Delay	20 80	30 120	75 300	Counts B:Sec.	Blower off delay. The time the blower stays on after the heating demand is lost.
3.04	Max_Ht_LT_Occurrences	1	3	15	Counts	Service relay activation. Maximum Primary and Secondary Limit occurrences stored before service relay is energized. If max value is set, service output is disabled. Note: Heating stage is not locked out.
3.05	High_Fire_Delay	15 30	15 30	80 160	Counts A:Sec.	The minimum low fire time before high fire is allowed.
3.06	HT_Off_Delay	15 30	50 100	150 300	Counts A:Sec.	Heating off delay.
3.07	Max_CAI_Proof_Switch_Occurrences	1	3	6	Counts	Service relay activation. Maximum Combustion Air Inducer proof switch occurrences stored before service output is energized. If max value is set, service output is disabled. Note: Heating stage is not locked out.
3.08	Max_Roll_Out_Switch_Occurrences	1	1	4	Counts	Service output activation. Maximum Roll Out Switch occurrences stored before service relay is energized. If max value is set, service output disabled. Note: Heating stage is not locked out.
3.09	Max_GV_Sense_Occurrences	1	3	6	Counts	Service output activation. Maximum Gas Valve Sense occurrences stored before service output is energized. If max value is set, service output is disabled. Note: Heating stage is not locked out.
3.10	Stg_Latch_Option	0	0	1	Option	Stage latch option. Used in zone sensor applications. 0: Latch Disabled 1: Latch Enabled
3.11	StgUp_Timer	0 0	57 912	225 3600	Counts F: Sec	Stage-up timer. The maximum time that lower stage runs before calling next heat stage. Used in zone sensor applications. Disabled if set to 0.
3.12	StgDn_Timer	0 0	0 0	225 3600	Counts F: Sec	Time delay before a lower stage turns off following a higher stage termination. Used in zone sensor applications.
3.13	MGV_Control_Mode	0	0	6	Option	Modulating Gas Valve Mode 0- A133 (GP1) not installed. 1- A133 (GP1 w/DIP set to MGV) installed, but no MGV. Data logging only. 2- Two-stage fire; min or 100% (with or without low-fire FAH) 3- 2 + modulating FAH 4- Direct mode. A11 (A133_P194-11) scaled to 0-100% and output on AO1. A12 (A133_P194_12) scaled to 0-100% and output on AO2. 5- DACH control; min to maximum (with or without lo-fire FAH) 6- 5 + modulating FAH Lighting sequence is followed for all modes; 2-6. See ECTO 3.14 and 3.15.
3.14	MGV_startup_Phase2_delay	2 4	8 16	150 300	Counts A: Sec.	Modulating gas startup delay. At startup, run burners on low stage main gas valve(s) with MGV(s) at 100% for ECTO 3.05 seconds. Increase burners to high stage of main gas valve(s) with MGV(s) opened to ECTO 3.15 for ECTO 3.14 seconds. Begin PID or staged control of MGV(s).
3.15	MGV_Max	60 60	80 80	100 100	Counts P:%	Modulating gas valve maximum.
3.16	MGV_Min	0 0	20 20	100 100	Counts P:%	Modulating gas valve minimum.
3.17	MGV_PID_ManRS	0 0	50 50	100 100	Counts P:%	Modulating gas valve PID manual reset value.
3.18	MGV_PID_P_Constant	0	40	127	Counts	Modulating gas valve PID proportional constant.
3.19	MGV_PID_I_Constant	0	0	127	Counts	Modulating gas valve PID integral constant.

BLOCK 3 GAS HEATING PARAMETERS

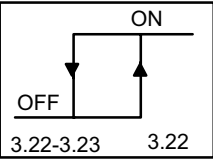
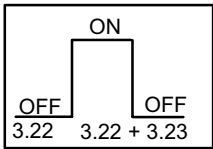
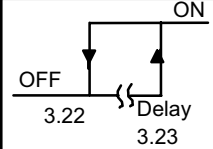
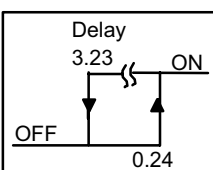
Control Parameter		Control Value			Units	Description
No.	Name	Min	Default	Max.		
3.20	MGV_PID_D_Constant	0	0	127	Counts	Modulating gas valve PID derivative constant.
3.21	DO_Mode_A133 (MGV mode)	0	0	127	Option	<p>GP1 Digital Out Mode = X + 32*Y + 16*Z</p> <p>Input source= X: 0- None. 1- Compressor 1 duty cycle. (Compressor crankcase heater function.) On when OAT <= ECTO 3.22 and >= ECTO 3.23 seconds have passed with compressor 1 off. Off when OAT > ECTO3.22 + 3degF (fixed deadband) or < ECTO 3.23 sec have passed with compressor 1 off 2- On when occupied. 3- On when blower on, 4- On when heating demand. 5- On when cooling demand. 6- On when heating or cooling demand. 7- System RH (Either A55_P114-10 or network RH) 8- System IAQ. (Either A55_P114-12 or network IAQ) 9- System OAT (Either A55_P114-13/14 or network OAT) 10-AI1 (A133_P194-6) (SP and DB set with ECTO3.22 & 3.23) 11-AI2 (A133_P194-7) (SP and DB set with ECTO3.22 & 3.23) 12-AI3 (A133_P194-8) (SP and DB set with ECTO3.22 & 3.23) 13-AI4 (A133_P194-9) (SP and DB set with ECTO3.22 & 3.23) 14-AO1 (A133_P194-11) 15-AO2 (A133_P194-12)</p> <p>Algorithm Y for input sources 7-15: 0 – Hysteresis loop On when input >= ECTO 3.22 Off when input < ECTO 3.22-ECTO 3.23</p>  <p>1—Window On when input is in range; >= ECTO 3.22 and <= ECTO 3.22 + ECTO 3.23 (Fixed 3-count hysteresis loop on rising and falling edges of window.)</p>  <p>2 - Delayed-on. On when input is >= ECTO 3.22 for >= ECTO 3.23 seconds. Off when input is < ECTO 3.22 - 3. (Fixed 3-count hysteresis loop on edge.)</p>  <p>3 - Delayed-off. On when input is >= ECTO 3.22. Off when input is < ECTO 3.22 - 3 for >= ECTO 3.23 seconds. (Fixed 3-count hysteresis loop on edge.)</p>  <p>Inversion Z: 0 - Output not inverted. 1 - Output inverted.</p> <p align="right">Graphs indicate output not inverted. See figure 48.</p>
3.22	DO_SP_A133 (MGV mode)	0 0 0 0 132 -0.5 0	127 5.0 996 100 51 0 2.5	255 10.0 2000 100 -31 0.5 5.0	Counts R:Volts I:ppm P:% Y:DegF M:"w.c. N:"w.c.	A133 (w/DIP set to MGV) digital output mode setpoint

ECTO

BLOCK 3 GAS HEATING PARAMETERS

Control Parameter		Control Value			Units	Description
No.	Name	Min	Default	Max.		
3.23	DO_DB_A133 (MGV mode)	2	13	255	Counts	A133 (w/DIP set to MGV) digital output mode deadband or delay.
		0	.50	10.0	R:Volts	
		16	102	2000	I:ppm	
		2	13	100	P:%	
		1	8	162	O:DegF	
		64	416	8160	D:Sec.	
		0.01	0.05	1.0	L:"w.c.	
		0	.25	5.0	N:"w.c.	

BLOCK 4 COOLING PARAMETERS

Control Parameter		Control Value			Units	Description
No.	Name	Min	Default	Max.		
4.01	CoolDn_Delay	0 0	56 1792	255 8160	Counts D:Sec.	Cool down time delay. Time that Y2 is ignored during cool down period (when first occupied + cool demand) This delay is only used if an economizer is used and the outdoor air is suitable.
4.02	BL_On_Delay	0 0	0 0	15 60	Counts B:Sec.	Blower on delay. The time before the blower turns on after a cooling demand.
4.03	BL_Off_Delay	0 0	0 0	60 240	Counts B:Sec.	Blower off delay. The time the blower stays on after the cooling demand is lost.
4.04	Max_Frz_Stat_Occurrences	1	3	5	Counts	Service output activation and compressor lockout. Maximum Freeze Stat occurrences stored before service relay is energized and compressor is locked-out. If value (4 or 5) is set, service output is disabled and compressor is not locked-out. If value 5 is set, alarms are not stored, but only displayed as they occur.
4.05	Cond_Fan_ReStart_Delay	0 0	3 6	8 16	Counts A:Sec.	Low ambient anti-windmilling condenser fan delay. The time period that the last operating fan is turned off before starting the next fan.
4.06	LAC_SP_Temp_1	113 60	144 40	191 10	Counts Y:DegF	Low ambient outdoor air limit temp. 1. Parameters 4.06 and 4.07 are used to shed fans. See Operation section. Temperature setting must be < or = 4.07.
4.07	LAC_SP_Temp_2	113 60	120 55	191 10	Counts Y:Deg.F	Low ambient outdoor air limit temp. 2. Parameters 4.06 and 4.07 are used to shed fans. See Operation section. Temperature setting must be > or = 4.06.
4.08	Compr_1_Low_Temp_Lockout	81 80	207 0	255 -31	Counts Y:DegF	Low ambient lockout for compressor 1. A value of 255 (-31°F) will disable low ambient lockout function. Temperature setting must be < or = 4.09.
4.09	Compr_2_Low_Temp_Lockout	81 80	207 0	255 -31	Counts Y:Deg.F	Low ambient lockout for compressor 2. A value of 255 (-31F) will disable low ambient lockout function. Temperature setting must be > or = 4.08 AND < or = 4.10.
4.10	Compr_3_Low_Temp_Lockout	81 80	207 0	255 -31	Counts Y:DegF	Low ambient lockout for compressor 3. A value of 255(-31F) will disable low ambient lockout function. Temperature setting must be > or = 4.09 AND < or = 4.11.
4.11	Compr_4_Low_Temp_Lockout	81 80	207 0	255 -31	Counts Y:DegF	Low ambient lockout for compressor 4. A value of 255 (-31F) will disable low ambient lockout function. Temperature setting must be > or = 4.10.
4.12	Compr_Min_Off_Delay	30 60	150 300	255 510	Counts A:Sec.	Compressor minimum off delay. Used on 1 PH units.
4.13	Compr_Min_Run_Time	30 60	120 240	255 510	Counts A:Sec.	Compressor minimum run time. Used on 3 PH units.
4.14	Max_HP_Occurrences	1	3	8	Counts	Maximum High Pressure occurrences that are stored before control locks off compressor stage and energizes the service output. If max value is set, lockout and service output features are disabled.
4.15	Max_LP_Occurrences	1	3	8	Counts	Maximum Low Pressure occurrences that are stored before control locks off compressor stage and energizes the service relay. If max value is set, lockout and service output features are disabled.
4.16	Cond_Fan_Delay	0 0	1 2	120 240	Counts A:Sec.	Condenser fan delay. Used only on 6 fan units.

ECTO

BLOCK 4 COOLING PARAMETERS

Control Parameter		Control Value			Units	Description
No.	Name	Min	Default	Max.		
4.17	Stg_2_Latch	0	0	1	Option	Stage 2 latch option. Used in zone sensor applications. 0: Latch Disabled 1: Latch Enabled
4.18	Stg_3_Latch	0	0	1	Option	Stage 3 latch option. Used in zone sensor applications. 0: Latch Disabled 1: Latch Enabled
4.19	Stg_4_Latch	0	0	1	Option	Stage 4 latch option. Used in zone sensor applications. 0: Latch Disabled 1: Latch Enabled
4.20	Stg_2_StgUp_Timer	0 0	57 912	225 3600	Counts F:Sec	Stage 2 stage up timer. The maximum time that cooling stage 1 runs before calling cooling stage 2. Used in zone sensor applications. Disabled if set to 0.
4.21	Stg_3_StgUp_Timer	0 0	57 912	225 3600	Counts F:Sec	Stage 3 stage up timer. The maximum time that cooling stage 2 runs before calling cooling stage 3. Used in zone sensor applications. Disabled if set to 0.
4.22	Stg_4_StgUp_Timer	0 0	57 912	225 3600	Counts F:Sec	Stage 4 stage up timer. The maximum time that cooling stage 3 runs before calling cooling stage 4. Used in zone sensor applications. Disabled if set to 0.
4.23	StgDn_Timer	0 0	57 912	225 3600	Counts F:Sec	Time delay before a lower stage turns off following a higher stage termination. Used in zone sensor applications.
4.24	Reheat_Control	0	0	7	Option	Reheat Control Mode 0- No reheat. 1- Supermarket reheat using De-Humidistat (Tstat mode only) 2- Supermarket reheat using RH sensor. 3- Humiditrol reheat. Conditions: Blower must be energized, Must be occupied, At least one previous cooling demand. 4- RH measurement / display. No Supermarket or Humiditrol reheat. 5- Humiditrol reheat. Conditions: At least one previous cooling demand. 6- Humiditrol reheat. Conditions: Blower must be energized, Must be occupied. 7- Humiditrol reheat. Conditions: None
4.25	Reheat_SP	0 0	60 60	100 100	Counts P:%RH	Percent relative humidity where supermarket or Humiditrol reheat demand is energized. Used of Reheat option 2,3,5,6,or 7. Reheat is de-energized at setpoint – deadband (ECTO 4.26). If value = 100, Humiditrol reheat is controlled by the digital input A67_P175-5 (TB1-24) only. Energized input signal calls for reheat demand. L Connection Network RH setpoint will override this setpoint. (Such as from NCP).
4.26	Reheat_RH_DB	1 1	3 3	10 10	Counts P:%RH	Reheat RH deadband. Used of Reheat option 2,3,5,6,or 7. Reheat is on when RH>=ECTO 4.25 and off when RH< ECTO 4.25 – ECTO 4.26.

ECTO

BLOCK 5 MISCELLANEOUS PARAMETERS						
Control Parameter		Control Value			Units	Description
No.	Name	Min	Default	Max.		
5.01	SMK_Alarm	0	0	7	Option	Smoke alarm control options. 0- Unit off. 1- Blower on, exhaust fan off, OD air damper open (positive pressure) 2- Blower on, exhaust fan on, OD air damper closed (negative pressure). On VAV units, exhaust fan will run at speed set in ECTO 8.19 with blower). 3- Blower on, exhaust fan on, OD air damper open (purge). On VAV units, exhaust fan will run at speed set in ECTO 8.19. 4- Blower off, exhaust fan on, OD air damper closed (negative pressure). On VAV units, exhaust fan will run at speed set in ECTO 8.19. 5- Blower on, exhaust fan on, OD air damper closed (negative pressure). On VAV units, exhaust fan will run to maintain pressure setpoint set in ECTO 8.19 with blower). 6- Blower on, exhaust fan on, OD air damper open (purge). On VAV units, exhaust fan will run to maintain pressure setpoint set in ECTO 8.19. 7- Blower off, exhaust fan on, OD air damper closed (negative pressure). On VAV units, exhaust fan will run to maintain pressure setpoint set in ECTO 8.19.
5.02	Error_Timed_Off_Delay	8 64	38 304	225 1800	Counts C:Sec.	Off time delay if a "no-run" error occurs. Off delay for error codes 5, 10, 11, 20, 21, 44, 45, 83, 86 and 87.
5.03	Display_Temp	0	0	1	Option	Degrees Celsius option for A55 Display 0: Displays degrees Fahrenheit 1: Displays degrees Celsius
5.04	CL_Staging	0	2	4	Option	Cooling staging options: 0: No cooling operation 1: Basic Tstat operation. Two cooling stages. Units with Economizers Y1=Free Cooling, Y2=adds all mechanical stages. 2: Basic Tstat operation. Two cooling stages. Units with Economizers Y1=Free Cooling, Y2= adds first stage of mechanical. 3: Basic Tstat operation. Three cooling stages. Y1 only = first stage, Y2 only = second stage, Y1+Y2 = third stage. Units with Economizers Y2 only adds first stage of mechanical, Y1+Y2 adds first and second stage of mechanical. 4: Discharge air control. Up to four stages.
5.05	RAT_LT	0	0	1	Option	Enables return air temperature limit option. Return air limits may be used for limiting zone temperatures. Continuous fan operation recommended.
5.06	RAT_HT_LT	95 100	117 85	154 60	Counts X:DegF	Return air limit for heating. If the return air heating limit is exceeded, the heating demands are interrupted. 5.05 MUST BE SET TO 1 TO ENABLE
5.07	RAT_CL_LT	124 80	146 65	154 60	Counts X:DegF	Return air limit for cooling. If the return air cooling limit is exceeded, the cooling demands are interrupted. 5.05 MUST BE SET TO 1 TO ENABLE
5.08	A42_Input_Occurrences	1	3	15	Counts	A42 input occurrences before service relay is energized. (A55_PI10-9)
5.09	HT_Staging	0	2	2	Option	Heating staging options: 0- No heating operation. 1- Discharge air control with up to 4 stages. 2- Thermostat operation.
5.10	LP_Strike_3_Run_Time_1	0 0	45 360	255 2040	Counts C:Sec.	Ignore LP trip when compressor run time less than this. LONG/HOT condition.
5.11	LP_Strike_3_Run_Time_2	0 0	90 720	255 2040	Counts C: Sec.	Ignore LP trip when compressor run time less than this. LONG/COLD condition.
5.12	LP_Strike_3_Run_Time_3	0 0	15 120	255 2040	Counts C:Sec.	Ignore LP trip when compressor run time less than this. SHORT/HOT condition.
5.13	LP_Strike_3_Run_Time_4	0 0	38 304	255 2040	Counts C:Sec.	Ignore LP trip when compressor run time less than this. SHORT/COLD condition.

BLOCK 5 MISCELLANEOUS PARAMETERS

Control Parameter		Control Value			Units	Description
No.	Name	Min	Default	Max.		
5.14	LP_Strike_3_Off_Time	28 3584	113 14464	169 21632	Counts E:Sec	Low Pressure Switch Strike Three compressor off time breakpoint for LONG/SHORT evaluation.
5.15	LP_Strike_3_Temp_SP	50 100	97 70	191 10	Counts Y:Deg.	Low Pressure Switch Strike Three outdoor air temperature breakpoint for HOT/COLD evaluation.
5.16	DCV_Max_Damper_Open	0 0	100 100	100 100	Counts P:%	Maximum allowed Demand Control Ventilation damper open position. (Set to 0 to disable IAQ). Also used for OAC.
5.17	DCV_Damper_Start_Open_SP	0 0	64 502	255 2000	Count I:PPM	Damper "start open" CO2 setpoint for Demand Control Ventilation. Level where fresh air damper begins to open.
	OAC_Dampr_Start_Open_SP	0	2.51	10	R: Volt	Damper "start open" setpoint for Outdoor Air Control. Level where fresh air damper begins to open.
5.18	DCV_Dampr_Full_Open_SP	0 0	128 1004	255 2000	Count I:PPM	Damper "full open" CO2 setpoint for Demand Control Ventilation. Level where fresh air damper is opened to maximum.
	OAC_Dampr_Full_Open_SP	0	5.02	10	R: Volt	Damper "full open" setpoint for Outdoor Air Control. Level where fresh air damper is opened to maximum.
5.19	DCV_Low_Temp_Override_Full_Closed	0 132	191 10	255 -31	Counts Y:Deg.F	Low outdoor air temp. where fresh air damper is closed to minimum position for Demand Control Ventilation and Outdoor Air Control (OAC).
5.20	DCV_Low_Temp_Override_Start_Closing	0 132	144 40	255 -31	Counts Y:Deg.F	Low outdoor air temp. where fresh air damper begins to close. Set ECTO 5.20 = 255 to disable the outdoor Low Temp. override of DCV operation. Also used for OAC.
5.21	DCV - High-Temp. Override Start Closing	0 132	89 75	255 -31	Counts Y:Deg.F	High outdoor air temp. where fresh air damper begins to close. Set 5.21 =0 to disable the outdoor High Temp override of DCV operation. Also used for OAC.
5.22	DCV_High_Temp_Override_Full_Close	0 132	42 105	255 -31	Counts Y:Deg.F	High outdoor air temp. where fresh air damper is closed to minimum position. Also used for OAC.
5.23	Free_CL_Max_Damper	0 0	100 100	100 100	Counts P:%	The maximum allowed fresh air damper opening for FREE COOLING.
5.24	Min_Damper_Position	0 0	101 101	100 100	Counts P: %	Minimum fresh air damper position during occupied operation. Value of 101 allows adjustment by potentiometer on economizer board A56 only.
5.25	Zone_Sensor_StartUp_Delay	15 2	15 2	225 30	Counts C:Min.	Start-up demand delay. Holds off all unit operation zone sensor and CAVB applications. Hold off FAH-Reheat, FAC, FAH options and all GP outputs. May be used to stagger unit start-ups. Does NOT delay demands in thermostat mode.
5.26	IAQ_Input_Source/Mode	0	0	3	Option	IAQ input source and mode. 0- DCV System IAQ. Either A55_P114-12 (TB1-15) or network IAQ 1- DCV System IAQ. Either A55_P114-12 (TB1-15) or network IAQ with no OAT limits. 2- Outdoor Air Control Sensor A24 (A133_P194-6) (TB22-6). 3- Outdoor Air Control Sensor A24 (A133_P194-6) (TB22-6) with no OAT limits.
5.27	Net_Sig_Sources	0	0	15	Option	Network Signal Sources Weight Description 1- IAQ (A63) 2- Zone Temp. (A2) 4- Outdoor Enthalpy (A7) 8- Indoor RH (A91) Option is sum of the weights for all input signals that are provided remotely over the network. Note: When network sensor is used the physical analog input is ignored. Loss of sensor alarms will not occur unless network communication is lost for 5 minutes, or has not been established within 5 minutes after reset.

ECTO

BLOCK 6 SYSTEM 1 PARAMETERS

Control Parameter		Control Value			Units	Description
No.	Name	Min	Default	Max.		
6.01	System_Mode	0	0	12	Option	System mode of operation. Control Value System Mode Backup Mode 0 Local Thermostat None 1 Zone Sensor None 2 Zone Sensor Local Thermostat 3 Zone Sensor Return Air Sensor 4 Remote Demand None 5 Remote Demand Local Thermostat 6 Remote Demand Return Air Sensor 7 Remote Demand Zone Sensor 8 Future Use None 9 Future Use Local Thermostat 10 Future Use Return Air Sensor 11 Future Use Zone Sensor 12 A138 4-Stg. Tstat Interface None
6.02	OCP_HT_BkUp_SP	20 95	120 70	240 40	Counts Z:DegF	Backup occupied heating setpoint. Used if the communications link is lost for 5 minutes between the IMC and NCP. Used only with zone sensor applications. Setpoint temperature must be < or = (6.04 - 6.15).
6.03	UnOcp_HT_BkUp_SP	20 95	160 60	240 40	Counts Z:DegF	Backup unoccupied heating setpoint. Used if the communications link is lost for 5 minutes between the IMC and NCP. Used only in zone sensor applications. Setpoint temperature must be < or = (6.05 - 6.15).
6.04	Ocp_CL_BkUp_SP	20 95	100 75	240 40	Counts Z:DegF	Backup occupied cooling setpoint. Used if the communications link is lost for 5 minutes between the IMC and NCP. Used only in zone sensor applications. Setpoint temperature must be > or = (6.02 + 6.15).
6.05	UnOcp_CL_BkUp_SP	20 95	60 85	240 40	Counts Z:DegF	Backup unoccupied cooling setpoint. Used if the communications link is lost for 5 minutes between the IMC and NCP. Used only in zone sensor applications. Setpoint temperature must be > or = (6.03 + 6.15).
6.06	Override_Timer	0 0	28 3584	225 28800	Counts E: Sec	After hours override timer. Only used on zone sensor applications without a Network Control Panel (NPC).
6.07	HT_Stg_DB	4 1	4 1	15 3.75	Counts W:DegF	Heating deadband. Used only with IMC zone sensor applications. Deadband must be < or = 6.15 - 6.08.
6.08	CL_Stg_DB	4 1	4 1	15 3.75	Counts W:DegF	Cooling deadband. Used only with zone sensor applications. Deadband must be < or = 6.15 - 6.07.
6.09	Stg_1_HT_Diff	0 0	2 0.5	12 3	Counts W:DegF	Heating stage 1 differential. Used only with zone sensor applications. Differential temperature must be < or = 6.11.
6.10	Stg_1_CL_Diff	0 0	2 0.5	12 3	Counts W:DegF	Cooling stage 1 differential. Used only with zone sensor applications. Differential temperature must be < or = 6.12.
6.11	Stg_2_HT_Diff	0 0	4 1	12 3	Counts W:DegF	Heating stage 2 differential. Used only with zone sensor applications. Differential temperature must be > or = 6.09.
6.12	Stg_2_CL_Diff	0 0	4 1	12 3	Counts W:DegF	Cooling stage 2 differential. Used only with zone sensor applications. Differential temperature must be > or = 6.10 AND < or = 6.13.
6.13	Stg_3_CL_Diff	0 0	6 1.5	12 3	Counts W:DegF	Cooling stage 3 differential. Used only with zone sensor applications. Differential temperature must be > or = 6.12 AND < or = 6.14.
6.14	Stg_4_CL_Diff	0 0	8 2	12 3	Counts W:DegF	Cooling stage 4 differential. Used only with zone sensor applications. Differential temperature must be > or = 6.13.
6.15	Zone_Sensor Autochange-over DB_Min	8 2	12 3	40 10	Counts W:DegF	Minimum autochangeover deadband temperature. Deadband must be > or = (6.07 + 6.08). Used in zone sensor applications.

ECTO

BLOCK 6 SYSTEM 1 PARAMETERS

Control Parameter		Control Value			Units	Description
No.	Name	Min	Default	Max.		
6.16	Autochange-over_Delay	15 60	75 300	225 900	Counts B: Sec	Autochangeover time delay. Delay between heating and cooling modes.
6.17	BL_Control-Zone_Sensor	0	0	1	Option	Blower control option for zone sensor applications during occupied periods. 0 = Blower cycles with demands 1 = Continuous blower
6.18	Zone_Sensor_Calibration	-20 -5	0 0	20 5	Counts W:DegF	Zone sensor calibration offset. Counts: -20 -16 -12 -8 -4 0 4 8 12 16 20 Offset -5 -4 -3 -2 -1 0 1 2 3 4 5 (Deg. F) Deg. F is an offset added to the zone sensor reading. Example: If the zone sensor is reading 2 deg. F high, it can be corrected by setting the count value to -8 (-2 deg. F offset).
6.19	Free_CL_Lockout_SP	112 60	161 Disabled	160 30	Counts Y:DegF	Free cooling lockout SP. Locks out free cooling when outdoor temperature is below this value. Default value 161 disables free cooling lockout.
6.20	FAH_SP	139 70	138 Disabled	183 40	Counts X:DegF	Fresh Air Heating setpoint. To enable FAH, set this to a value between 40F (183) and 70F(139). Minimum value (138) disables Fresh Air Heating.
6.21	FAH_Stg_DB	7 5	15 10	22 15	Counts V:DegF	Fresh Air Heating stage deadband.
6.22	FAH_Min_Cycle_Time	15 120	60 480	225 180 0	Counts C:Sec	Fresh Air heating minimum cycle time.
6.23	Free_Cooling_Supply_SP	146 65	161 55	176 45	Counts X:DegF	Economizer modulates dampers to maintain supply air temperature (RT6) at this setpoint during free cooling. DACC reset applies. See ECTO 8.01-8.07.
6.24	Stg_3_HT_Diff	0 0	6 1.5	12 3	Counts W:DegF	Heating stage 3 differential temperature. Used only with zone sensor applications. Differential temperature must >= ECTO 6.11.
6.25	Stg_4_HT_Diff	0 0	8 2	12 3	Counts W:DegF	Heating stage 4 differential temperature. Used only with zone sensor applications. Differential temperature must >= ECTO 6.24.
6.26	Economizer_Free_CL_SP	0 0 132	0 0 132	255 20 -31	Counts J:mA Y:DegF	Economizer outdoor air suitable for free cooling setpoint. A56 DIP switch selects "TEMP" or enthalpy "ODE" mode. A56 POT selects enthalpy ABCD or differential mode. Conditions for free cooling: A56 DIP SW settings POT set to A-D POT set to DIFF ECTO Counts = 0 TEMP RAT > OAT RAT > OAT ODE ODE < POT IDE > ODE ECTO Counts not =0 TEMP OAT < ECTO RAT>OAT+ECTO ODE = Outdoor enthalpy. IDE = Indoor enthalpy. OAT = Outdoor Temp. RAT=Return Temp.

ECTO

BLOCK 7 SYSTEM 2 PARAMETERS

Control Parameter		Control Value			Units	Description
No.	Name	Min	Default	Max.		
7.01	FAH_Stg_Diff	0 0	3 2	30 20	Counts V:DegF	Fresh Air Heating stage differential. 0 value for first stage heating only for Fresh Air Heating.
7.02	Reheat_FAH_OAT_SP	113 60	136 45	175 20	Counts Y:DegF	Outdoor air temperature setpoint that enables fresh air heating for reheat demand and opens damper to ECTO 7.03 when outdoor air is less than setpoint.
7.03	Reheat_FAH_%_Damper	5 5	40 40	100 100	Counts P:%	Fresh air damper position during Fresh Air Heating reheat operation.
7.04	Reheat_FAH_SP	139 70	138 Disabled	183 40	Counts X:DegF	Fresh Air Heating Reheat setpoint. Minimum value of 138 disables FAH-Reheat.
7.05	FAT_Auto-change_Delay	28 896	56 1792	225 7200	Counts D: Sec.	Fresh air Tempering (FAH or FAC) auto-changeover delay.
7.06	FAC_SP	109 90	108 Disabled	154 60	Counts X:DegF	Fresh Air Cooling setpoint. To enable FAC, set this to a value between 60F (154) and 90F(109). Minimum value of 91F (108) disables FAC.
7.07	FAC_Stg_DB	7 5	15 10	22 15	Counts V:DegF	Fresh Air Cooling stage deadband.
7.08	FAC_Min_Cycle	15 120	60 480	225 1800	Counts C: Sec.	Fresh Air Cooling minimum cycle time.
7.09	FAC_Stg_Diff	0 0	3 2	30 20	Counts V:DegF	Fresh Air Cooling stage differential between stages. Set to 0 for first stage cooling only for Fresh Air Cooling.
7.10	DACH_OCP_SP	36 140	80 110	124 80	Counts X:DegF	Discharge Air Control Heating setpoint during occupied period.
7.11	DACH_Un-OCP_SP	36 140	95 100	124 80	Counts X:DegF	Discharge Air Control Heating setpoint during unoccupied period.
7.12	DACH_Stg_DB	7 5	7 5	30 20	Counts V:DegF	Discharge Air Control Heating deadband.
7.13	DACH_&_FAH_StgUp_Delay	0 0	45 180	225 900	Counts B: Sec.	Discharge Air Control Heating and Fresh Air Heating stage-up time delay.
7.14	DACH_&_FAH_StgDn_Delay	0 0	30 120	150 600	Counts B: Sec.	Discharge Air Control Heating and Fresh Air Heating stage-down time delay.
7.15	DACH_Stg_Diff	3 2	3 2	30 20	Counts V:DegF	Discharge Air Control Heating stage differential
7.16	DACC_OCP_SP	124 80	161 55	183 40	Counts X:DegF	Discharge Air Control Cooling setpoint during occupied period.
7.17	DACC_UnOCP_SP	124 80	146 65	183 40	Counts X:DegF	Discharge Air Control Cooling setpoint during unoccupied period.
7.18	DACC_Stg_DB	7 5	7 5	30 20	Counts V:DegF	Discharge Air Control Cooling stage deadband.
7.19	DACC_&_FAC_StgUp_Delay	0 0	45 180	225 900	Counts B: Sec.	Discharge Air Control Cooling and Fresh Air Cooling stage-up delay.
7.20	DACC_&_FAC_StgDn_Delay	0 0	30 120	150 600	Counts B: Sec.	Discharge Air Control Cooling and Fresh Air Cooling stage-down time delay.
7.21	DACC_Stg_Diff	3 2	3 2	30 20	Counts V:DegF	Discharge Air Cooling stage differential.

ECTO

BLOCK 7 SYSTEM 2 PARAMETERS

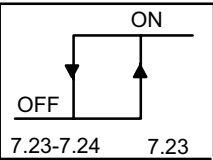
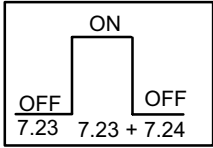
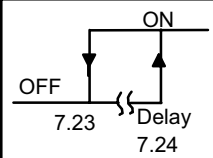
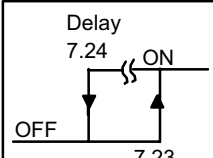
Control Parameter		Control Value			Units	Description
No.	Name	Min	Default	Max.		
7.22	Service_ Output_ Control_Mode	0	0	127	Option	<p>A55 Service Output Control Mode = $X + 32*Y + 16*Z$</p> <p>Input source = X: 0- None. Standard Service Output based on alarms. 1- Compressor 1 duty cycle. (Compressor crankcase heater function.) On when OAT \leq ECTO 7.23 and \geq ECTO 7.24 seconds have passed with compressor 1 off. Off when OAT $>$ ECTO 7.23 + 3 deg F (fixed deadband) or $<$ ECTO 7.24 seconds have passed with compressor 1 off 2- On when occupied. 3- On when blower on, 4- On when heating demand. 5- On when cooling demand. 6- On when heating or cooling demand. 7- System RH (Either A55_ P114-10 or network RH) 8- System IAQ. (Either A55_ P114-12 or network IAQ) 9- System OAT (Either A55_ P114-13/14 or network OAT)</p> <p>Algorithm Y for input sources 7-9: 0 – Hysteresis loop On when input \geq ECTO 7.23 Off when input $<$ ECTO 7.23-ECTO 7.24</p>  <p>1—Window On when input is in range; \geq ECTO 7.25 and \leq ECTO 7.23 + ECTO 7.24 (Fixed 3-count hysteresis loop on rising and falling edges of window.)</p>  <p>2 - Delayed-on. On when input is \geq ECTO 7.23 for \geq ECTO 7.24 seconds. Off when input is $<$ ECTO 7.23-3. (Fixed 3-count hysteresis loop on edge.)</p>  <p>3 - Delayed-off. On when input is \geq ECTO 7.23. Off when input is $<$ ECTO 7.23 - 3 for \geq ECTO 7.24 seconds. (Fixed 3-count hysteresis loop on edge.)</p>  <p>Inversion Z: 0 - Output not inverted. 1 - Output inverted.</p> <p align="right">Graphs indicate output not inverted. See figure 48.</p>
7.23	Service_ Output_SP	0 0 132	127 996 51	255 2000 -31	Counts I:ppm P: % Y:DegF	A55 service relay output setpoint.

ECTO

BLOCK 7 SYSTEM 2 PARAMETERS

Control Parameter		Control Value			Units	Description
No.	Name	Min	Default	Max.		
7.24	Service_ Output_ DB	2 16 2 1 64	13 102 13 8 416	255 2000 100 162 8160	Counts l:ppm P: % O:DegF D:Sec.	A55 service relay output deadband or delay.
7.25	Load_Shed_ Option	0	0	15	Option	<p>Load shedding option used to disable half of available mechanical cooling. Select the load shedding input signal source:</p> <ul style="list-style-type: none"> 0-No load shedding. 2-EM1 GLO (A56_P115-4) (A56 wDIP NOT in set to global mode). 4-DI1 (A133_P194-1, DIP set to GP) 6-DI2 (A133_P194-2, DIP set to GP) 8-DI1 (A133_P194-1, DIP set to MGV). 10-DI2 (A133_P194-2, DIP set to MGV) 12-DI1 (A133_P194-1, DIP set to VAV) 14-DI2 (A133_P194-2, DIP set to VAV) <p>These options select load shedding that will round up (fractional compressors on). 1 compressor unit – compressor is not disabled. 3 compressor unit – only compressor 3 is disabled. Add one to any option to select load shedding that will round down (fractional compressors off). 1 compressor unit – compressor is disabled. 3 compressor unit – compressors 2 and 3 are disabled.</p>

BLOCK 8 SYSTEM 3 PARAMETERS

Control Parameter		Control Value			Units	Description
No.	Name	Min	Default	Max.		
8.01	DACC_RS_ Total_LT	7 5	15 10	29 20	Counts V:DegF	Discharge Air Control Cooling total reset limit. This limits the total DACC reset allowed. Also used to reset free cooling setpoint (6.23).
8.02	DACC_RAT_ RS_SP	124 80	139 70	169 50	Counts X:DegF	Discharge Air Control Cooling return air reset setpoint. Also used to reset free cooling setpoint (6.23).
8.03	DACC_RAT_ RS_Proportional_Band.	1 1	15 10	44 30	Counts V:DegF	Discharge Air Control Cooling return air reset proportional band. Also used to reset free cooling setpoint (6.23).
8.04	DACC_RAT_ RS_Adjust_Band	0 0	0 0	44 30	Counts V:DegF	Discharge Air Control Cooling return air reset adjustment band. 0 disables return air cooling reset. Also used to reset free cooling setpoint (6.23).
8.05	DACC_OAT_ RS_SP	50 100	81 80	144 40	Counts Y:DegF	Discharge Air Control Cooling outdoor air temperature cooling reset setpoint. Also used to reset free cooling setpoint (6.23).
8.06	DACC_OAT_ RS_Proportional_Band.	1 1	31 20	94 60	Counts O:DegF	Discharge Air Control Cooling outdoor ambient temperature cooling proportional band. Also used to reset free cooling setpoint (6.23).
8.07	DACC_OAT_ RS_Adjust_Band	0 0	0 0	47 30	Counts O:DegF	Discharge Air Control Cooling outdoor temperature ambient cooling adjustment reset band. 0 disables outdoor air cooling reset. Also used to reset free cooling setpoint (6.23).
8.08	DACH_RS_ Limit	7 5	15 10	29 20	Counts V:DegF	Discharge Air Control Heating reset limit. This limits the total DACH reset allowed.
8.09	DACH_RAT_ RS_SP.	124 80	139 70	169 50	Counts X:DegF	Discharge Air Control Heating return air heating reset setpoint.
8.10	DACH_RAT_ RS_Proportional_Band	1 1	15 10	44 30	Counts V:DegF	Discharge Air Control Heating return air heating reset proportional band.
8.11	DACH_RAT_ RS_Adjust_Band	0 0	0 0	44 30	Counts V:DegF	Discharge Air Control Heating return reset adjustment band. 0 value disables return air heating reset.
8.12	DACH_OAT_ RS_SP	113 60	144 40	255 -31	Counts Y:DegF	Discharge Air Control Heating outdoor temperature reset setpoint.

ECTO

BLOCK 8 SYSTEM 3 PARAMETERS

Control Parameter		Control Value			Units	Description																																																																																													
No.	Name	Min	Default	Max.																																																																																															
8.13	DACH_OAT_RS_Proportional_Band.	1 1	31 20	94 60	Counts O:DegF	Discharge Air Control Heating temperature reset proportional band.																																																																																													
8.14	DACH_OAT_RS_Adjust_Band	0 0	0 0	47 30	Counts O:DegF	Discharge Air Control Heating outdoor temperature reset adjustment band. 0 disables outdoor temperature heating reset																																																																																													
8.15						Reserved.																																																																																													
8.16	Exh_Fan_Control	0	0	23	Option	<p align="center">Single Stage (Controlled by A56_P115-3 Output)</p> <table border="1"> <thead> <tr> <th>Mode</th> <th>Enable</th> <th>Input</th> </tr> </thead> <tbody> <tr><td>0-</td><td>Blower</td><td>D_POS</td></tr> <tr><td>1-</td><td>Always</td><td>A133_P194-1</td></tr> <tr><td>2-</td><td>OCP</td><td>A133_P194-1</td></tr> <tr><td>3-</td><td>Blower</td><td>A133_P194-1</td></tr> <tr><td>4-</td><td>Always</td><td>A133_P194-7</td></tr> <tr><td>5-</td><td>Occupied</td><td>A133_P194-7</td></tr> <tr><td>6-</td><td>Blower</td><td>A133_P194-7</td></tr> <tr><td>7-</td><td>A133_P194-1</td><td>A133_P194-7</td></tr> </tbody> </table> <p align="center">Two Stage Exhaust Fan (Controlled by A56_P115-3 and A133_P194-5 Outputs)</p> <table border="1"> <thead> <tr> <th>Mode</th> <th>Enable</th> <th>Input 1</th> <th>Input 2</th> </tr> </thead> <tbody> <tr><td>8-</td><td>Blower</td><td>D_POS</td><td>D_POS</td></tr> <tr><td>9-</td><td>Always</td><td>A133_P194-1</td><td>A133_P194-2</td></tr> <tr><td>10-</td><td>Occupied</td><td>A133_P194-1</td><td>A133_P194-2</td></tr> <tr><td>11-</td><td>Blower</td><td>A133_P194-1</td><td>A133_P194-2</td></tr> <tr><td>12-</td><td>Always</td><td>A133_P194-7</td><td>A133_P194-7</td></tr> <tr><td>13-</td><td>Occupied</td><td>A133_P194-7</td><td>A133_P194-7</td></tr> <tr><td>14-</td><td>Blower</td><td>A133_P194-7</td><td>A133_P194-7</td></tr> <tr><td>15-</td><td>A133_P194-1</td><td>A133_P194-7</td><td>A133_P194-7</td></tr> </tbody> </table> <p>For option 9-15, Stage 2 will not turn on until ECTO 8.25 seconds after stage 1. Stage 1 won't turn off until ECTO 8.22 seconds after stage 2 turns off.</p> <p>VFD (PID) controlled Exhaust Fan with on/off cycling at minimum speed (Cycled by A56_P115-3 and Speed controlled by VFD)</p> <table border="1"> <thead> <tr> <th>Mode</th> <th>Enable</th> <th>Analog Input</th> </tr> </thead> <tbody> <tr><td>16</td><td>Always</td><td>A133_P194-7</td></tr> <tr><td>17-</td><td>Occupied</td><td>A133_P194-7</td></tr> <tr><td>18-</td><td>Blower</td><td>A133_P194-7</td></tr> <tr><td>19-</td><td>A133_P194-1</td><td>A133_P194-7</td></tr> </tbody> </table> <p>Min. speed cycling: On at 10% over setpoint. Off after 30 seconds at minimum speed. Minimum 30 seconds off.</p> <p>VFD (PID) controlled Exhaust Fan (Always on when enabled) (Cycled by A56_P115-3 and Speed controlled by VFD)</p> <table border="1"> <thead> <tr> <th>Mode</th> <th>Enable</th> <th>Analog Input</th> </tr> </thead> <tbody> <tr><td>20</td><td>Always</td><td>A133_P194-7</td></tr> <tr><td>21</td><td>Occupied</td><td>A133_P194-7</td></tr> <tr><td>22</td><td>Blower</td><td>A133_P194-7</td></tr> <tr><td>23</td><td>A133_P194-1</td><td>A133_P194-7</td></tr> </tbody> </table> <p>Always on at least minimum speed when enabled.</p>	Mode	Enable	Input	0-	Blower	D_POS	1-	Always	A133_P194-1	2-	OCP	A133_P194-1	3-	Blower	A133_P194-1	4-	Always	A133_P194-7	5-	Occupied	A133_P194-7	6-	Blower	A133_P194-7	7-	A133_P194-1	A133_P194-7	Mode	Enable	Input 1	Input 2	8-	Blower	D_POS	D_POS	9-	Always	A133_P194-1	A133_P194-2	10-	Occupied	A133_P194-1	A133_P194-2	11-	Blower	A133_P194-1	A133_P194-2	12-	Always	A133_P194-7	A133_P194-7	13-	Occupied	A133_P194-7	A133_P194-7	14-	Blower	A133_P194-7	A133_P194-7	15-	A133_P194-1	A133_P194-7	A133_P194-7	Mode	Enable	Analog Input	16	Always	A133_P194-7	17-	Occupied	A133_P194-7	18-	Blower	A133_P194-7	19-	A133_P194-1	A133_P194-7	Mode	Enable	Analog Input	20	Always	A133_P194-7	21	Occupied	A133_P194-7	22	Blower	A133_P194-7	23	A133_P194-1	A133_P194-7
Mode	Enable	Input																																																																																																	
0-	Blower	D_POS																																																																																																	
1-	Always	A133_P194-1																																																																																																	
2-	OCP	A133_P194-1																																																																																																	
3-	Blower	A133_P194-1																																																																																																	
4-	Always	A133_P194-7																																																																																																	
5-	Occupied	A133_P194-7																																																																																																	
6-	Blower	A133_P194-7																																																																																																	
7-	A133_P194-1	A133_P194-7																																																																																																	
Mode	Enable	Input 1	Input 2																																																																																																
8-	Blower	D_POS	D_POS																																																																																																
9-	Always	A133_P194-1	A133_P194-2																																																																																																
10-	Occupied	A133_P194-1	A133_P194-2																																																																																																
11-	Blower	A133_P194-1	A133_P194-2																																																																																																
12-	Always	A133_P194-7	A133_P194-7																																																																																																
13-	Occupied	A133_P194-7	A133_P194-7																																																																																																
14-	Blower	A133_P194-7	A133_P194-7																																																																																																
15-	A133_P194-1	A133_P194-7	A133_P194-7																																																																																																
Mode	Enable	Analog Input																																																																																																	
16	Always	A133_P194-7																																																																																																	
17-	Occupied	A133_P194-7																																																																																																	
18-	Blower	A133_P194-7																																																																																																	
19-	A133_P194-1	A133_P194-7																																																																																																	
Mode	Enable	Analog Input																																																																																																	
20	Always	A133_P194-7																																																																																																	
21	Occupied	A133_P194-7																																																																																																	
22	Blower	A133_P194-7																																																																																																	
23	A133_P194-1	A133_P194-7																																																																																																	

ECTO

BLOCK 8 SYSTEM 3 PARAMETERS

Control Parameter		Control Value			Units	Description
No.	Name	Min	Default	Max.		
8.17	Exh_Fan_Stg_1_SP	0 0	50 50	100 100	Counts P:%	Speed setpoint for stage 1 exhaust fan when using a VFD for controlling exhaust fan in staged mode.
8.18	Exh_Fan_Stg_2_SP	0 0	100 100	100 100	Counts P:%	Speed setpoint for stage 2 exhaust fan when using a VFD for controlling exhaust fan in staged mode.
8.19	Exh_Fan_SP_for_SMK	0 0.5	50 -0.3	255 0.5	Counts M:"w.c.	Exhaust fan smoke mode setpoint for PID option control
	Staged_SMK	0	50	100	P:%	Staged setpoint for during smoke alarm. Value used depends on smoke mode (ECTO 5.01)
8.20	Exh_Fan_SP	0 -0.5	50 -0.3	255 0.5	Counts M:"w.c.	Exhaust fan setpoint for PID option control
	Stage_1_SP	0 -0.5	50 -0.3	100 0.5	P:% M:"w.c.	Stage 1 setpoint.
8.21	Exh_Fan_Min	0 0	10 10	255 100	Counts P:%	Exhaust fan minimum speed.
	Staged_1_DB	0 0	10 0.04	100 1.0	P:% L:"w.c.	Staged 1 deadband.
8.22	Exh_Fan_ManRS	0 0	50 50	100 100	Counts P: %	Exhaust fan PID loop manual reset value.
	Stg_1_Off_Delay	0	100	200	A:Sec.	Stage 1 off-delay. (Only used for 2 stage operation)
8.23	Exh_Fan_PID_P_Constant	0	20	255	Counts	Exhaust fan PID loop proportional constant. The P constant must be limited to 127. Recommended setting = 17.
	Stg_2_SP	0 0 -0.5	.78 20 -42	10.0 100 0.5	R:Volts P:% M:"w.c.	Staged 2 setpoint.
8.24	Exh_Fan_PID_I_Constant	0	64	255	Counts	Exhaust fan PID loop integral constant. The I constant must be limited to 127. Recommended setting = 12.
	Stg_2_DB	0 0	64 0.25	100 1.0	P:% L:"w.c.	Staged 2 deadband.
8.25	Exh_Fan_PID_D_Constant	0	0	127	Counts	Exhaust fan PID loop derivative constant.
	Stg_2_On_Delay	0	0	254	A: Sec.	Staged 2 on-delay.

BLOCK 9 OPTIONAL A133 BOARD IN GP MODE (DIP SWITCH SET TO GP) PARAMETERS

Control Parameter		Control Value			Units	Description																																																								
No.	Name	Min	Default	Max.																																																										
9.01	AO1_control_mode	0	0	11	Option	Analog output channel 1 control mode. 0 - No operation. Analog Output 1 off. <table border="0"> <tr> <td>Enabled When</td> <td>Control</td> </tr> <tr> <td>1- Occupied</td> <td>PID setpoint A</td> </tr> <tr> <td>Unoccupied</td> <td>PID setpoint B</td> </tr> <tr> <td>2- Occupied</td> <td>PID setpoint A</td> </tr> <tr> <td>Unoccupied</td> <td>Staged output B</td> </tr> <tr> <td>3- Occupied</td> <td>Staged output A</td> </tr> <tr> <td>Unoccupied</td> <td>PID setpoint B</td> </tr> <tr> <td>4- Occupied</td> <td>Staged output A</td> </tr> <tr> <td>Unoccupied</td> <td>Staged output B</td> </tr> <tr> <td>5- Blower On</td> <td>PID setpoint A</td> </tr> <tr> <td>Blower Off</td> <td>PID setpoint B</td> </tr> <tr> <td>6- Blower On</td> <td>PID setpoint A</td> </tr> <tr> <td>Blower Off</td> <td>Staged output B</td> </tr> <tr> <td>7- Blower On</td> <td>Staged output A</td> </tr> <tr> <td>Blower Off</td> <td>PID setpoint B</td> </tr> <tr> <td>8- Blower On</td> <td>Staged output A</td> </tr> <tr> <td>Blower Off</td> <td>Staged output B</td> </tr> <tr> <td>9 -DI2 (A133_P194-2) on</td> <td>PID setpoint B (1)</td> </tr> <tr> <td>DI1 (A133_P194-1) on</td> <td>PID setpoint A (2)</td> </tr> <tr> <td>Otherwise off</td> <td></td> </tr> <tr> <td>10-DI2 (A133_P194-2) on</td> <td>PID setpoint B (1)</td> </tr> <tr> <td>DI1 (A133_P194-1) on</td> <td>Staged output A (2)</td> </tr> <tr> <td>Otherwise off</td> <td></td> </tr> <tr> <td>11-DI2 (A133_P194-2) on</td> <td>Staged output B (1)</td> </tr> <tr> <td>DI1 (A133_P194-1) on</td> <td>Staged output A (2)</td> </tr> <tr> <td>Otherwise off</td> <td></td> </tr> <tr> <td>(1) -DI1 (A133_P194-2) doesn't matter</td> <td></td> </tr> <tr> <td>(2) -DI2 (A133_P194-1) is off</td> <td></td> </tr> </table>	Enabled When	Control	1- Occupied	PID setpoint A	Unoccupied	PID setpoint B	2- Occupied	PID setpoint A	Unoccupied	Staged output B	3- Occupied	Staged output A	Unoccupied	PID setpoint B	4- Occupied	Staged output A	Unoccupied	Staged output B	5- Blower On	PID setpoint A	Blower Off	PID setpoint B	6- Blower On	PID setpoint A	Blower Off	Staged output B	7- Blower On	Staged output A	Blower Off	PID setpoint B	8- Blower On	Staged output A	Blower Off	Staged output B	9 -DI2 (A133_P194-2) on	PID setpoint B (1)	DI1 (A133_P194-1) on	PID setpoint A (2)	Otherwise off		10-DI2 (A133_P194-2) on	PID setpoint B (1)	DI1 (A133_P194-1) on	Staged output A (2)	Otherwise off		11-DI2 (A133_P194-2) on	Staged output B (1)	DI1 (A133_P194-1) on	Staged output A (2)	Otherwise off		(1) -DI1 (A133_P194-2) doesn't matter		(2) -DI2 (A133_P194-1) is off	
Enabled When	Control																																																													
1- Occupied	PID setpoint A																																																													
Unoccupied	PID setpoint B																																																													
2- Occupied	PID setpoint A																																																													
Unoccupied	Staged output B																																																													
3- Occupied	Staged output A																																																													
Unoccupied	PID setpoint B																																																													
4- Occupied	Staged output A																																																													
Unoccupied	Staged output B																																																													
5- Blower On	PID setpoint A																																																													
Blower Off	PID setpoint B																																																													
6- Blower On	PID setpoint A																																																													
Blower Off	Staged output B																																																													
7- Blower On	Staged output A																																																													
Blower Off	PID setpoint B																																																													
8- Blower On	Staged output A																																																													
Blower Off	Staged output B																																																													
9 -DI2 (A133_P194-2) on	PID setpoint B (1)																																																													
DI1 (A133_P194-1) on	PID setpoint A (2)																																																													
Otherwise off																																																														
10-DI2 (A133_P194-2) on	PID setpoint B (1)																																																													
DI1 (A133_P194-1) on	Staged output A (2)																																																													
Otherwise off																																																														
11-DI2 (A133_P194-2) on	Staged output B (1)																																																													
DI1 (A133_P194-1) on	Staged output A (2)																																																													
Otherwise off																																																														
(1) -DI1 (A133_P194-2) doesn't matter																																																														
(2) -DI2 (A133_P194-1) is off																																																														
9.02	AO1_SP_A	0 0 -0.5 0	127 5.00 0 2.5	255 10.0 0.5 5.0	Counts R:Volts M:"w.c. N:"w.c.	Analog output channel 1 setpoint A																																																								
	Stg_Output_A	0	100	100	P:%	Staged output A																																																								
9.03	AO1_SP_B	0 0 -0.5 0	127 5.00 0 2.5	255 10.0 0.5 5.0	Counts R:Volts M:"w.c. N:"w.c.	Analog output channel 1 setpoint B																																																								
	Stg_Output_B	0	100	100	P:%	Staged output B.																																																								
9.04	AO1_Startup_Value	0 0	50 50	100 100	Counts P:%	Analog output channel 1 startup value. Value set to Analog Output during the optional startup time delay set by ECTO 9.05.																																																								
9.05	AO1_Startup_Delay	0 0	0 0	250 500	Counts A:Sec.	Analog output channel 1 startup delay. Optional time delay before PID loop starts.																																																								
9.06	AO1_Min_Output	0 0	20 20	100 100	Counts P:%	Analog output channel 1 minimum output.																																																								
9.07	AO1_Max_Output	0 0	100 100	100 100	Counts P:%	Analog output channel 1 maximum output.																																																								
9.08	AO1_PID_ManRS	0 0	50 50	100 100	Counts P:%	Analog output channel 1 PID loop manual reset value.																																																								
9.09	AO1_PID_P_Constant	0	0	127	Counts	Analog output channel 1 PID loop proportional constant.																																																								
9.10	AO1_PID_I_Constant	0	0	127	Counts	Analog output channel 1 PID loop integral constant.																																																								
9.11	AO1_PID_D_Constant	0	0	127	Counts	Analog output channel 1 PID loop derivative constant.																																																								

ECTO

BLOCK 9 OPTIONAL A133 BOARD IN GP MODE (DIP SWITCH SET TO GP) PARAMETERS

Control Parameter		Control Value			Units	Description
No.	Name	Min	Default	Max.		
9.12	AO2_Control_Mode	0	0	11	Option	Analog output channel 2 control mode. 0 - No operation. Analog Output 2 off. Enabled When 1- Occupied Unoccupied 2- Occupied Unoccupied 3- Occupied Unoccupied 4- Occupied Unoccupied 5- Blower On Blower Off 6- Blower On Blower Off 7- Blower On Blower Off 8- Blower On Blower Off 9- DI2 (A133_P194-2) on DI1 (A133_P194-1) on Otherwise off 10-DI2 (A133_P194-2) on DI1 (A133_P194-1) on Otherwise off 11-DI2 (A133_P194-2) on DI1 (A133_P194-1) on Otherwise off (1)-DI1 (A133_P194-2) doesn't matter. (2)-DI2 (A133_P194-1) is off Control PID setpoint A PID setpoint B PID setpoint A Staged output B Staged output A PID setpoint B Staged output A Staged output B PID setpoint A PID setpoint B PID setpoint A Staged output B Staged output A PID setpoint B Staged output A Staged output B PID setpoint B(1) PID setpoint A(2) PID setpoint B (1) Staged output A (2) Staged output B(1) Staged output A (2)
9.13	AO2_SP_A	0 0 -0.5 0	127 5.00 0 2.5	255 10.0 0.5 5.0	Counts R:Volts M:"w.c. N:"w.c.	Analog output channel 2 setpoint A
	Stg_Output_A	0	100	100	P:%	Staged output A.
9.14	AO2_SP_B	0 0 -0.5 0	127 5.00 0 2.5	255 10.0 0.5 5.0	Counts R:Volts M:"w.c. N:"w.c.	Analog output channel 2 setpoint B.
	Stg_Output_B	0	100	100	P:%	Staged output B.
9.15	AO2_Startup_Value	0 0	50 50	100 100	Counts P:%	Analog output channel 2 startup value. Value set to Analog Output during the optional startup time delay set by ECTO 9.16.
9.16	AO2_Startup_Delay	0 0	0 0	250 500	Counts A:Sec.	Analog output channel 2 startup delay. Optional time delay before PID loop starts.
9.17	AO2_Min_Output	0 0	20 20	100 100	Counts P:%	Analog output channel 2 minimum output.
9.18	AO2_Max_Output	0 0	100 100	100 100	Counts P:%	Analog output channel 2 maximum output.
9.19	AO2_PID_ManRS	0 0	50 50	100 100	Counts P:%	Analog output channel 2 PID loop manual reset value.
9.20	AO2_PID_P_Constant	0	0	127	Counts	Analog output channel 2 PID loop proportional constant.
9.21	AO2_PID_I_Constant	0	0	127	Counts	Analog output channel 2 PID loop integral constant.
9.22	AO2_PID_D_Constant	0	0	127	Counts	Analog output channel 2 PID loop derivative constant.

ECTO

BLOCK 9 OPTIONAL A133 BOARD IN GP MODE (DIP SWITCH SET TO GP) PARAMETERS

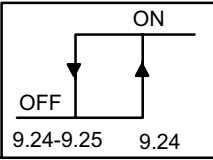
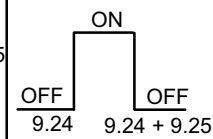
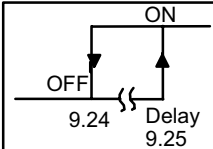
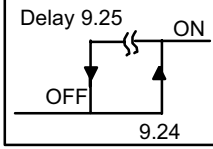
Control Parameter		Control Value			Units	Description
No.	Name	Min	Default	Max.		
9.23	DO_Control_Mode	0	0	127	Option	<p>GP1 Digital Out Control Mode = X + 32*Y + 16*Z</p> <p>Input source = X: 0- None. 1- Compressor 1 duty cycle. (Compressor crankcase heater function.) On when OAT <= ECTO 9.24 and >= ECTO 9.25 seconds have passed with compressor 1 off. Off when OAT > ECTO 9.24 + 3 deg F (fixed deadband) or < ECTO 9.25 seconds have passed with compressor 1 off. 2- On when occupied. 3- On when blower on, 4- On when heating demand. 5- On when cooling demand. 6- On when heating or cooling demand. 7- System RH (Either A55_P114-10 or network RH) 8- System IAQ. (Either A55_P114-12 or network IAQ) 9- System OAT (Either A55_P114-13/14 or network OAT) 10-On base on AI1. (A133_P194-6) 11-On based on AI2. (A133_P194-7) 12-On based on AI3. (A133_P194-8) 13-On based on AI4. (A133_P194-9) 14-On based on AO1. (A133_P194-11) 15-On based on AO2. (A133_P194-12)</p> <p>Algorithm Y for input sources 7-15: 0 – Hysteresis loop On when input >= ECTO 9.24 Off when input < ECTO 9.24-ECTO 9.25</p>  <p>1—Window On when input is in range; >= ECTO 9.24 and <= ECTO 9.24 + ECTO 9.25 (Fixed 3-count hysteresis loop on rising and falling edges of window.)</p>  <p>2 - Delayed-on. On when input is >= ECTO 9.24 for >= ECTO 9.25 seconds. Off when input is < ECTO 9.24 - 3. (Fixed 3-count hysteresis loop on edge.)</p>  <p>3 - Delayed-off. On when input is >= ECTO 9.24. Off when input is < ECTO 9.24 - 3 for >= ECTO 9.25 seconds. (Fixed 3-count hysteresis loop on edge.)</p>  <p>Inversion Z: 0 - Output not inverted. 1 - Output inverted.</p> <p align="right">Graphs indicate output not inverted. See figure 48.</p>

ECTO

BLOCK 9 OPTIONAL A133 BOARD IN GP MODE (DIP SWITCH SET TO GP) PARAMETERS						
Control Parameter		Control Value			Units	Description
No.	Name	Min	Default	Max.		
9.24	DO_SP	0	127	255	Counts	Digital output control mode setpoint
		0	5.0	10.0	R:Volts	
		16	996	2000	I:ppm	
		0	100	100	P: %	
		132	51	-31	Y:DegF	
		-0.5	0	0.5	M:"w.c.	
		0	2.5	5.0	N:"w.c.	
9.25	DO_DB	2	13	255	Counts	Digital output control mode deadband or delay.
		0	.50	10.0	R:Volts	
		0	102	2000	I:ppm	
		2	13	100	P: %	
		1	8	162	O:DegF	
		64	416	8160	D:Sec.	
		0.01	.05	1.0	L:"w.c.	
		0	.25	5.0	N:"w.c.	

**TABLE 49
ECTO PARAMETER CODE CONVERSION TABLE**

Codes A Through F									
Counts	A		B		C		D	E	F
	Sec.	Min.	Sec.	Min.	Sec.	Min.	Min.	Hrs.	Min.
0	0	0	0	0	0	0	0	0	0
10	20	0.33	40	0.67	80	1.33	5.33	0.36	2.67
20	40	0.67	80	1.33	160	2.67	10.67	0.71	5.33
30	60	1.00	120	2.00	240	4.00	16.00	1.07	8.00
40	80	1.33	160	2.67	320	5.33	21.33	1.42	10.67
50	100	1.67	200	3.33	400	6.67	26.67	1.78	13.33
60	120	2.00	240	4.00	480	8.00	32.00	2.13	16.00
70	140	2.33	280	4.67	560	9.33	37.33	2.49	18.67
80	160	2.67	320	5.33	640	10.67	42.67	2.84	21.33
90	180	3.00	360	6.00	720	12.00	48.00	3.20	24.00
100	200	3.33	400	6.67	800	13.33	53.33	3.56	26.67
110	220	3.67	440	7.33	880	14.67	58.67	3.91	29.33
120	240	4.00	480	8.00	960	16.00	64.00	4.27	32.00
130	260	4.33	520	8.67	1040	17.33	69.33	4.62	34.67
140	280	4.67	560	9.33	1120	18.67	74.67	4.98	37.33
150	300	5.00	600	10.00	1200	20.00	80.00	5.33	40.00

Codes I Through O							
Counts	I	J	L	M	N	O	
	CO2 ppm	mA	Pres. "w.c.	Pres. "w.c.	Pres. "w.c.	Differential Temp.	
						F	C
0	0	0	0	-0.5	0	0	0.00
10	78.43	0.78	0.04	-0.46	0.20	6.36	3.53
20	156.86	1.57	0.08	-0.42	0.39	12.72	7.07
30	235.29	2.35	0.12	-0.38	0.59	19.08	10.60
40	313.72	3.14	0.16	-0.34	0.78	25.44	14.13
50	392.15	3.92	0.20	-0.30	0.98	31.80	17.67
60	470.58	4.71	0.24	-0.26	1.18	38.16	21.20
70	549.01	5.49	0.27	-0.23	1.37	44.52	24.73
80	627.44	6.27	0.31	-0.19	1.57	50.88	28.27
90	705.87	7.06	0.35	-0.15	1.76	57.24	31.80
100	784.3	7.84	0.39	-0.11	1.96	63.60	35.33
110	862.73	8.63	0.43	-0.07	2.16	69.96	38.87
120	941.16	9.41	0.47	-0.03	2.35	76.32	42.40
130	1019.6	10.20	0.51	0.01	2.55	82.68	45.93
140	1098	10.98	0.55	0.05	2.75	89.04	49.47
150	1176.5	11.76	0.59	0.09	2.94	95.40	53.00
160	1254.9	12.55	0.63	0.13	3.14	101.76	56.53
170	1333.3	13.33	0.67	0.17	3.33	108.12	60.07
180	1411.7	14.12	0.71	0.21	3.53	114.48	63.60
190	1490.2	14.90	0.75	0.25	3.73	120.84	67.13
200	1568.6	15.69	0.78	0.28	3.92	127.20	70.67
210	1647	16.47	0.82	0.32	4.12	133.56	74.20
220	1725.5	17.25	0.86	0.36	4.31	139.92	77.73
230	1803.9	18.04	0.90	0.40	4.51	146.28	81.27
240	1882.3	18.82	0.94	0.44	4.71	152.64	84.80
250	1960.8	19.61	0.98	0.48	4.90	159.00	88.33
255	2000	20.00	1.00	0.50	5.00	162.18	90.10

Codes P Through Z												
Counts	P	R	V		W		X		Y		Z	
	%	VDC	Diff. Temp.		Diff. Temp.		Temp.		Temp.		Temp.	
			F	C	F	C	F	C	F	C	F	C
0	0	0	0	0	0	0	164.45	73.58	131.56	55.31	100	37.78
10	10	0.39	6.79	3.77	2.50	1.39	157.66	69.81	125.20	51.78	97.50	36.39
20	20	0.78	13.58	7.55	5.00	2.78	150.87	66.04	118.84	48.24	95.00	35.00
30	30	1.18	20.38	11.32	7.50	4.17	144.07	62.26	112.48	44.71	92.50	33.61
40	40	1.57	27.17	15.09	10.00	5.56	137.28	58.49	106.12	41.18	90.00	32.22
50	50	1.96	33.96	18.87	12.50	6.94	130.49	54.72	99.76	37.64	87.50	30.83
60	60	2.35	40.75	22.64	15.00	8.33	123.70	50.94	93.40	34.11	85.00	29.44
70	70	2.75	47.54	26.41	17.50	9.72	116.91	47.17	87.04	30.58	82.50	28.06
80	80	3.14	54.34	30.19	20.00	11.11	110.11	43.40	80.68	27.04	80.00	26.67
90	90	3.53	61.13	33.96	22.50	12.50	103.32	39.62	74.32	23.51	77.50	25.28
100	100	3.92	67.92	37.73	25.00	13.89	96.53	35.85	67.96	19.98	75.00	23.89
110	100	4.31	74.71	41.51	27.50	15.28	89.74	32.08	61.60	16.44	72.50	22.50
120	100	4.71	81.50	45.28	30.00	16.67	82.95	28.30	55.24	12.91	70.00	21.11
130	100	5.10	88.30	49.05	32.50	18.06	76.15	24.53	48.88	9.38	67.50	19.72
140	100	5.49	95.09	52.83	35.00	19.44	69.36	20.76	42.52	5.84	65.00	18.33
150	100	5.88	101.88	56.60	37.50	20.83	62.57	16.98	36.16	2.31	62.50	16.94
160	100	6.27	108.67	60.37	40.00	22.22	55.78	13.21	29.80	-1.22	60.00	15.56
170	100	6.67	115.46	64.15	42.50	23.61	48.99	9.44	23.44	-4.76	57.50	14.17
180	100	7.06	122.26	67.92	45.00	25.00	42.19	5.66	17.08	-8.29	55.00	12.78

190	100	7.45	129.05	71.69	47.50	26.39	35.40	1.89	10.72	-11.82	52.50	11.39
200	100	7.84	135.84	75.47	50.00	27.78	28.61	-1.88	4.36	-15.36	50.00	10.00
210	100	8.24	142.63	79.24	52.50	29.17	21.82	-5.66	-2.00	-18.89	47.50	8.61
220	100	8.63	149.42	83.01	55.00	30.56	15.03	-9.43	-8.36	-22.42	45.00	7.22
230	100	9.02	156.22	86.79	57.50	31.94	8.23	-13.20	-14.72	-25.96	42.50	5.83
240	100	9.41	163.01	90.56	60.00	33.33	1.44	-16.98	-21.08	-29.49	40.00	4.44
250	100	9.80	169.80	94.33	62.50	34.72	-5.35	-20.75	-27.44	-33.02	37.50	3.06
255	100	10.00	173.20	96.22	63.75	35.42	-8.75	-22.64	-30.62	-34.79	36.25	2.36

**TABLE 50
CODE CONVERSION**

Code	Type	Value	Convert Counts to Value	Convert Value to Counts
A	Timer	Seconds	2 x Counts	Seconds / 2
B	Timer	Seconds	4 x Counts	Seconds / 4
C	Timer	Seconds	8 x Counts	Seconds / 8
D	Timer	Seconds	32 x Counts	Seconds / 32
E	Timer	Seconds	128 x Counts	Seconds / 128
F	Timer	Seconds	16 x Counts	Seconds / 16
I	IAQ	ppm CO ₂	7.843 x Count	ppm / 7.843
J	0-20mA	mA	Counts / 12.75	mA x 12.75
L	"w.c. Differential For M	"w.c.	Counts / 255	"w.c. x 255
M	"w.c. (-.05 - +.05)	"w.c.	(Count - 127.5) / 255	("w.c. x 255) + 127.5
N	"w.c. Differential For N	"w.c.	Count / 51	"w.c. x 51
N	N (0.0 - 5.0)	"w.c.	Count / 51	"w.c. x 51
O	OAT Differential	Degrees °F	0.6360 x Count	Deg F / 0.6360
P	Percent	Percent	Counts (maximum = 100)	Percent
R	0-10V	Volt	Count / 25.5	Volt x 25.5
V	RAT, DAT Differential	Degrees °F	0.6792 x Counts	Deg F / 0.6792
W	ZAT Differential	Degrees °F	Counts / 4	Deg F x 4
X	RAT, DAT	Degrees °F	164.45 - (.6792 x Counts)	(164.45 - Deg F) / 0.6792
Y	OAT	Degrees °F	131.56 - (.6360 x Counts)	(131.56 - Deg F) / 0.6360
Z	ZAT	Degrees °F	100 - (Counts / 4)	(100 - Deg F) x 4

IMC Board Inputs and Outputs

When necessary, individual inputs and outputs may be read at the IMC board connectors. IMC boards are shown on wiring diagrams as dashed boxes. See shaded areas in figure 68. Parts of the IMC boards will be located in all wiring diagram sections. See figure 69 to find the jack/plug connector on the IMC board(s). Use table 51 in this section for a description of each pin number, a description of the input or output, and the type of input or output.

Example:

- To determine if 24 volts is being supplied to the K3 blower contactor:
- 1- Using the unit wiring diagram and figure 69, locate K3 and identify appropriate IMC board and jack/plug. (A55 main board and J/P113-11.)
 - 2- Find the I&O table for P113. Pin 11 shows a 24 volt output to the blower.

TYPICAL 17-1/2 & 20 TON WIRING DIAGRAM

SHADED AREAS INDICATE IMC BOARD

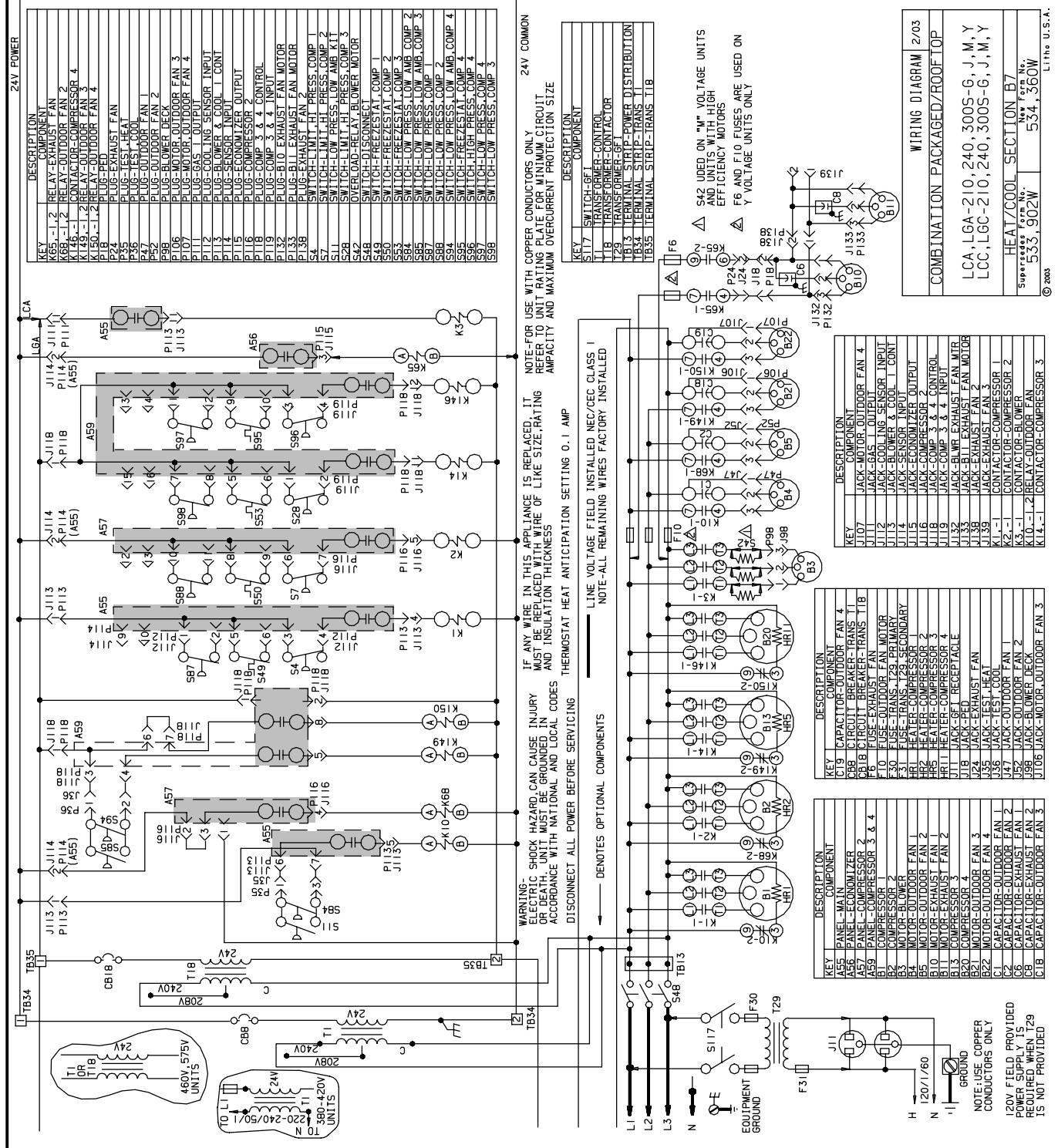

KEY	DESCRIPTION
K65-1,2	RELAY-EXHAUST FAN
K68-1,2	RELAY-OUTDOOR FAN 2
K146-1	CONTACTOR-COMPRESSOR 4
K149-1,2	RELAY-OUTDOOR FAN 3
K150-1,2	RELAY-OUTDOOR FAN 4
P24	PLUG-EXHAUST FAN
P35	PLUG-TEST HEAT
P36	PLUG-TEST COOL
P47	PLUG-OUTDOOR FAN 1
P48	PLUG-OUTDOOR FAN 2
P56	PLUG-MOTOR, OUTDOOR FAN 3
P107	PLUG-MOTOR, OUTDOOR FAN 4
P111	PLUG-GAS I OUTPUT
P112	PLUG-COOLING SENSOR INPUT
P113	PLUG-BLOWER & COOL I CONT
P114	PLUG-ECONOMIZER OUTPUT
P115	PLUG-COMPRESSOR 2
P116	PLUG-COMPRESSOR 3
P118	PLUG-COMP 3 & 4 CONTROL
P119	PLUG-COMP 3 & 4 INPUT
P132	PLUG-B10 EXHAUST FAN MOTOR
P133	PLUG-B11 EXHAUST FAN MOTOR
P136	PLUG-OUTDOOR FAN MOTOR
S7	SWITCH-OUTDOOR FAN PRESS. COMP 1
S7	SWITCH-OUTDOOR FAN PRESS. COMP 2
S11	SWITCH-LOW PRESS. LOW AMB. K11
S28	SWITCH-LIMIT, HI. PRESS. COMP 3
S42	OVERLOAD-RELAY, BLOWER MOTOR
S48	SWITCH-DISCONNECT
S49	SWITCH-FREESTAT, COMP 1
S49	SWITCH-FREESTAT, COMP 2
S53	SWITCH-FREESTAT, COMP 3
S54	SWITCH-LOW PRESS. LOW AMB. COMP 2
S55	SWITCH-LOW PRESS. LOW AMB. COMP 3
S57	SWITCH-LOW PRESS. COMP 1
S58	SWITCH-LOW PRESS. COMP 2
S59	SWITCH-FREESTAT, COMP 4
S66	SWITCH-HIGH PRESS. COMP 4
S97	SWITCH-LOW PRESS. COMP 4
S98	SWITCH-LOW PRESS. COMP 3

KEY	DESCRIPTION
S117	SWITCH-GR. CONTROL
T18	TRANSFORMER-CONTACTOR
T29	TRANSFORMER-GR. I
TB13	TERMINAL STRIP-POWER DISTRIBUTION
TB34	TERMINAL STRIP-TRANS 1
TB35	TERMINAL STRIP-TRANS 1 TIB

KEY	DESCRIPTION
J107	JACK-MOTOR, OUTDOOR FAN 4
J112	JACK-GAS I, INDOOR FAN MOTOR
J113	JACK-BLOWER & COOL I CONT
J114	JACK-SENSOR INPUT
J115	JACK-ECONOMIZER OUTPUT
J116	JACK-COMPRESSOR 2
J118	JACK-COMP 3 & 4 CONTROL
J132	JACK-TEMP. EXHAUST FAN
J133	JACK-B11 EXHAUST FAN MOTOR
J138	JACK-EXHAUST FAN 3
J139	JACK-EXHAUST FAN 4
K1-1	CONTACTOR-COMPRESSOR 1
K2-1	CONTACTOR-COMPRESSOR 2
K3-1	CONTACTOR-BLOWER
K14-1	CONTACTOR-COMPRESSOR 3

KEY	DESCRIPTION
C19	CAPACITOR-OUTDOOR FAN 4
C98	CIRCUIT BREAKER-TRANS 1
C98	CIRCUIT BREAKER-TRANS 1 TIB
F6	FUSE-EXHAUST FAN MOTOR
F10	FUSE-TRANS. T29-PRIMARY
F31	FUSE-TRANS. T29-SECONDARY
H1	HEATER-COMPRESSOR 1
H2	HEATER-COMPRESSOR 2
H5	HEATER-COMPRESSOR 3
H11	HEATER-EXHAUST FAN 1
H18	JACK-TEST RECEPTACLE
J24	JACK-EXHAUST FAN
J35	JACK-TEST HEAT
J36	JACK-TEST COOL
J47	JACK-OUTDOOR FAN 1
K8	CAPACITOR-EXHAUST FAN 2
K9	CAPACITOR-EXHAUST FAN 3
K10	CAPACITOR-OUTDOOR FAN 3

KEY	DESCRIPTION
A55	PANEL-MAIN
A56	PANEL-ECONOMIZER
A57	PANEL-COMPRESSOR 2
A59	PANEL-COMPRESSOR 3 & 4
B2	COMPRESSOR 2
B3	MOTOR-BLOWER
B4	MOTOR-OUTDOOR FAN 1
B5	MOTOR-OUTDOOR FAN 2
B10	MOTOR-EXHAUST FAN 1
B11	MOTOR-EXHAUST FAN 2
B13	COMPRESSOR 4
B20	COMPRESSOR 4
B21	MOTOR-OUTDOOR FAN 3
B22	MOTOR-OUTDOOR FAN 4
C1	CAPACITOR-OUTDOOR FAN 1
C2	CAPACITOR-OUTDOOR FAN 2
C8	CAPACITOR-EXHAUST FAN 2
C9	CAPACITOR-EXHAUST FAN 3
C10	CAPACITOR-OUTDOOR FAN 3

NOTE-FOR USE WITH COPPER CONDUCTORS ONLY
REFER TO UNIT RATING PLATE FOR MINIMUM CIRCUIT
CAPACITY AND MAXIMUM OVERCURRENT PROTECTION SIZE

IF ANY WIRE IN THIS APPLIANCE IS REPLACED, IT
MUST BE REPLACED WITH WIRE OF LIKE SIZE, RATING
AND INSULATION THICKNESS

WARNING-ELECTRIC SHOCK HAZARD, CAN CAUSE INJURY
OR DEATH. UNIT MUST BE GROUNDED IN
ACCORDANCE WITH NATIONAL AND LOCAL CODES
DISCONNECT ALL POWER BEFORE SERVICING

LINE VOLTAGE FIELD INSTALLED NEC/IEC CLASS 1
NOTE-ALL REMAINING WIRES FACTORY INSTALLED

24V COMMON

NOTE-USE COPPER
CONDUCTORS ONLY
120V FIELD PROVIDED
POWER SUPPLY IS
NOT PROVIDED

24V COMMON

NOTE-USE COPPER
CONDUCTORS ONLY
120V FIELD PROVIDED
POWER SUPPLY IS
NOT PROVIDED

24V COMMON

WIRING DIAGRAM 2/03

COMBINATION PACKAGED/ROOF TOP

LCA, LGA-210, 240, 300S-6, J, M, Y
LCC, LGC-210, 240, 300S-6, J, M, Y

HEAT/COOL SECTION B7

Supp. Catalog Form No. 533, 902W Key Form No. 534, 360W

© 2003 Litho U.S.A.

FIGURE 68

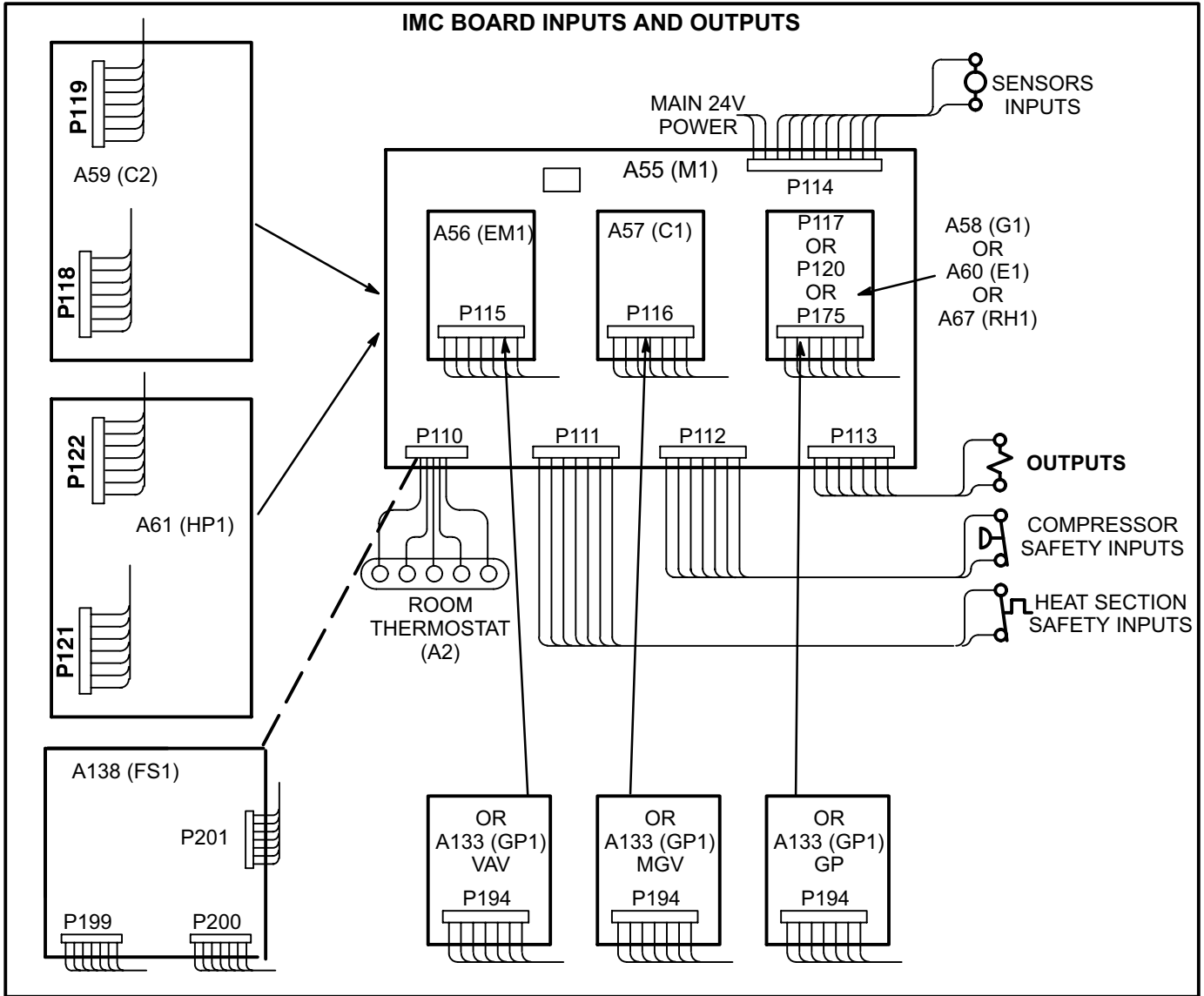

FIGURE 69

Signal Types: AI-Analog Input DI-Digital Input (on/off) RES-Resistance Temperature Sensor (NTC)
 AO-Analog Output DO-Digital Output (on/off)

TABLE 51 IMC BOARD INPUTS AND OUTPUTS			
PLUG #P110 CONTROL INPUTS			
PIN #	LABEL	DESCRIPTION	TYPE
1	COM	ROOM THERMOSTAT COMMON	24VAC COM
2	OCF	OCCUPIED (ON WHEN OCCUPIED)	24VAC DI
3	Y2	HIGH COOL DEMAND	24VAC DI
4	Y1	LOW COOL DEMAND	24VAC DI
5	W2	HIGH HEAT DEMAND	24VAC DI
6	W1	LOW HEAT DEMAND	24VAC DI
7	G	BLOWER DEMAND	24VAC DI
8	A17	SMOKE DETECTOR (NORM. OFF)	24VAC DI
9	A42	OPTION 1 (NORM. ON)	24VAC DI

I/O

**TABLE 51
IMC BOARD INPUTS AND OUTPUTS (CONTINUED)**

PLUG #P111 HEAT SAFETY			
PIN #	LABEL	DESCRIPTION	TYPE
1	S10-C	PLT1-C (PRI. LIMIT 1)	SW (24VAC)
2	S10-NC	PLT1-NC (PRI. LIMIT1)	
3	S10-NO	PLT1-NO (PRI. LIMIT1)	
4	S21-C	SLT1-C (SEC. LIMIT1)	SW (24VAC)
5	S21-NC	SLT1-NC (SEC. LIMIT1)	
6	S47	ROS1 (ROLL OUT SWITCH 1)	SW (24VAC)
7			
8	S18	CAB1(COMB. AIR PROOF 1 SWITCH)	SW (24VAC)
9			
10	GV1	GV1 (GAS VALVE 1 SENSE)	24VAC DI
11	TB35-1	24 VAC (FOR HEATING OUTPUTS & BLOWER)	24VAC POWER
12	TB35-2	RETURN (FOR TRANS. PROT.)	24VAC POWER
PLUG #P112 COOLING SAFETY			
1	S87	LP1 (LOW PRESS. 1)	SW (24VAC)
2			
3	S4	HP1 (HIGH PRESS. 1)	SW (24VAC)
4			
5	S49	FRZ1 (FREEZE STAT 1)	SW (24VAC)
6			
7	S6	DFT1 (DEF. TEMP. STAT 1)	SW (24VAC)
8			
9	S46	DFP1 (DEF. PRESS. 1)	SW (24VAC)
10			
11	S27	DFS (DIRTY FILTER SWITCH)	SW (24VAC)
12			
13	S52	AFS (AIR FLOW SWITCH)	SW (24VAC)
14			
PLUG #P113 OUTPUTS			
1	TB34-1	24VAC (FOR RELAY OUTS)	24VAC POWER
2	TB34-2	RETURN (FOR TRANS. PROT.)	24VAC POWER
3	SR	SERVICE RELAY OUTPUT (24VAC OUT)	24VAC DO
4	K1-A	COMPRESSOR 1	24VAC DO
5	K10-A	FAN 1	24VAC DO
6	S11	LOW PRESS. (LOW AMB. CONTROL FAN 1)	SW (24VAC)
7	S11		
8	L1	RV1 (REVERSING VALVE 1)	24VAC DO
9	K13-A	CAB 1 (COMBUSTION AIR BLOWER RELAY 1)	24 VAC DO
10	W2	H2/E2 (HEAT2/ELECTRIC HEAT 2)	24 VAC DO
11	K3-A	BLOWER	24 VAC DO
12	A3-1	H1/E1 (HEAT1/ ELECTRIC HEAT 1)	24 VAC DO

0/1

**TABLE 51
IMC BOARD INPUTS AND OUTPUTS (CONTINUED)**

PLUG #P114 ANALOG INPUTS			
PIN #	LABEL	DESCRIPTION	TYPE
1	TB34-2	COMMON (FOR MAIN CONTROL)	24VAC POWER
2	TB34-1	24VAC (FOR MAIN CONTROL)	24VAC POWER
3	A2 (-)	ZONE SENSOR	RES (0-5VDC)
4	A2 (+)		
5	RT16	RAT (RETURN AIR TEMP)	RES (0-5VDC)
6	RT16 (+)		
7	RT6	DAT (DISCHARGE AIR TEMP)	RES (0-5VDC)
8	RT6 (+)	DAT (DISCHARGE AIR TEMP)	RES (0-5VDC)
9	A91 (-)	RH SENSOR (0-10VDC = 0-100% RH)	0-10VDC AI
10	A91 (+)		
11	A63 (-)	IAQ (INDOOR AIR QUALITY)	0-10VDC AI
12	A63 (+)		
13	RT17 (-)	OAT (OUTDOOR AMB. TEMP)	RES (0-5VDC)
14	RT17 (+)		
PLUG #P115 A56 EM1 ECONOMIZER BOARD			
1	TB34-2	COMMON	24 VAC POWER
2	VOT	DAMPER CONTROL	2-10 VDC AO
3	K65	EXHAUST FAN	24VAC DO
4	GLO	GLOBAL CONTROL INPUT	24VAC DI
5	A62 +	INDOOR ENTHALPY SENSOR HONEYWELL C7400A	4-20mA AI
6	A62 S		
7	A7 +	OUTDOOR ENTHALPY SENSOR HONEYWELL C7400A	4-20 mA AI
8	A7 S		
9	DPOS	DAMPER POSITION FEEDBACK	2-10VDC AI
PLUG #P116 A57 C1			
1	TB34-2	RETURN (FOR TRANS. PROT.)	COM (24VAC)
2	S84	LOW PRESS (LOW AMB. CONTROL, FAN 2)	SW (24VAC)
3	S84		
4	K68	FAN 2	24VAC DO
5	K2	COMPRESSOR 2	24VAC DO
6	S7	HP2 (HIGH PRESS. 2)	SW (24VAC)
7	S7		
8	S50	FRZ2 (FREEZE STAT 2)	SW (24VAC)
9	S50		
10	S88	LP2 (LOW PRESS. 2)	SW (24VAC)
11	S88		
12	RT13	RESERVED	RES (0-5VDC)
13	RT13		

I/O

**TABLE 51
IMC BOARD INPUTS AND OUTPUTS (CONTINUED)**

PLUG #P117 A58 G1 BOARD			
PIN #	LABEL	DESCRIPTION	TYPE
1	TB35-1	24VAC IN	24VAC POWER
2	TB35-2	RETURN (FOR TRANS. PROT.)	24VAC POWER
3	K19-A	CAB2 (COMBUSTION AIR BLOWER RELAY 2)	24VAC DO
4	W2	H4 (HEAT 4)	24VAC DO
5	A12-1	H3 (HEAT 3)	24VAC DO
6	S99-C	PLT2-C (PRI. LIMIT2)	SW (24VAC)
7	S99-NC	PLT2-NC(PRI. LIMIT2)	
8	S100-C	SLT2-C (SEC. LIMIT2)	SW (24VAC)
9	S100-NC	SLT2-NC (SEC. LIMIT2)	
10	S69	ROS2 (ROLL OUT SWITCH2)	SW (24VAC)
11	S69		
12	S45	CAB2 (COMB. AIR PROOF 2 SWITCH)	SW (24VAC)
13	S45		
14	GV2	GV2 (GAS VALVE 2 SENSE)	24VAC DI
PLUG #P118 A59 C2 BOARD			
1	TB35-1	24VAC	24VAC POWER
2	TB35-2	COMMON	24VAC POWER
3	S11	LOW PRESS (LOW AMB. , FAN 3)	SW (24VAC)
4	S11		
5	K149	FAN 3	24VAC DO
6	S85	LOW PRESS (LOW AMB., FAN 4)	SW (24VAC)
7	S85		
8	K150	FAN 4	24VAC DO
9	K152	FAN 5	24VAC DO
10	K153	FAN 6	24VAC DO
11	K14	COMPRESSOR 3	24VAC DO
12	K146	COMPRESSOR 4	24VAC DO
15	RT14	RESERVED	RES (0-5 VDC)
16	RT14		

**TABLE 51
IMC BOARD INPUTS AND OUTPUTS (CONTINUED)**

PLUG #P119 COMPRESSOR SAFETY			
PIN #	LABEL	DESCRIPTION	TYPE
1	S28	HP3 (HIGH PRESS. 3)	SW (24VAC)
2	S28		
3	S96	HP4 (HIGH PRESS. 4)	SW (24VAC)
4	S96		
5	S53	FRZ3 (FREEZE STAT 3)	SW (24VAC)
6	S53		
7	S98	LP3 (LOW PRESS. 3)	SW (24VAC)
8	S98		
9	S95	FRZ4 (FREEZE STAT 4)	SW (24VAC)
10	S95		
11	S97	LP4 (LOW PRESS. 4)	SW (24VAC)
12	S97		
13	RT15	RESERVED	RES (0-5VDC)
14	RT15		
PLUG #P120 A60 E1 BOARD			
1	K9-5	24 VAC IN	24VAC POWER
2	T2	RETURN (FOR TRANS. PROT.)	24VAC POWER
3	K17	E3 (ELECTRIC HEAT 3)	24VAC DO
4	K18	E4 (ELECTRIC HEAT 4)	24VAC DO
PLUG #P121 A61 HP1 BOARD			
1	TB34-1	24VAC IN	24VAC POWER
2	TB34-2	COMMON	24VAC POWER
3	K68	FAN 2	24VAC DO
4	S84	LOW PRESS (LOW AMB. CONTROL, FAN 2)	SW (24VAC)
5	S84		
6	K149	FAN 3 (FAN 2 ON B BOX HEAT PUMP)	24VAC DO
7	K150	FAN 4	24VAC DO
8	L2	RV2 (REVERSING VALVE 2)	24VAC DO
9	K2	COMPRESSOR 2	24VAC DO
PLUG #P122 COMPRESSOR SAFETY			
1	S7	HP2 (HIGH PRESS. 2)	SW (24VAC)
2	S7		
3	S50	FRZ2 (FREEZE STAT 2)	SW (24VAC)
4	S50		
5	S88	LP2 (LOW PRESS. 2)	SW (24VAC)
6	S88		
7	S9	DFT2 (DEFROST TEMP. STAT 2)	SW (24VAC)
8	S9		
9	S104	DFP2 (DEFROST PRESS. 2)	SW (24VAC)
10	S104		
11	RT13	RESERVED	RES. (0-5VDC)
12	RT13		

I/O

PLUG #P175 A67 HUMIDITROL RH1 CONTROL BOARD			
PIN #	LABEL	DESCRIPTION	TYPE
1	TB34-C	COMMON	24VAC POWER
2	TB34-H	24VAC	24VAC POWER
3	L14	REHEAT SOLENOID #1	24VAC DO
4	L30	REHEAT SOLENOID #2	24VAC DO
5	--	DIGITAL INPUT 1 (USED FOR DIGITAL HUMIDITROL OPTION)	24VAC DI
6	--	DIGITAL INPUT 2 (Reserved for future use)	24VAC DI
PLUG #P199 A138 FOUR STAGE CONTROL BOARD - INPUTS FROM TB8 WHEN PRESENT			
1	W4	DIGITAL INPUT- THERMOSTAT DEMAND, HEATING 4TH STAGE.	24VAC DI
2	W3	DIGITAL INPUT- THERMOSTAT DEMAND, HEATING 3 RD STAGE.	24VAC DI
3	Y4	DIGITAL INPUT- THERMOSTAT DEMAND, COOLING 4 TH STAGE.	24VAC DI
4	Y3	DIGITAL INPUT- THERMOSTAT DEMAND, COOLING 3 RD STAGE.	24VAC DI
TB17 A138 FOUR STAGE CONTROL BOARD - FIELD WIRING WHEN NO TB8			
1	W4	DIGITAL INPUT- THERMOSTAT DEMAND, HEATING 4 TH STAGE.	24VAC DI
2	W3	DIGITAL INPUT- THERMOSTAT DEMAND, HEATING 3 RD STAGE.	24VAC DI
3	Y4	DIGITAL INPUT- THERMOSTAT DEMAND, COOLING 4 TH STAGE.	24VAC DI
4	Y3	DIGITAL INPUT- THERMOSTAT DEMAND, COOLING 3 RD STAGE.	24VAC DI
PLUG #P200 A138 FOUR STAGE CONTROL BOARD - INPUTS FROM TB1			
1	C	COMMON	24VAC
2	OCP	DIGITAL INPUT- THERMOSTAT DEMAND, OCCUPIED	24VAC DI
3	Y2	DIGITAL INPUT- THERMOSTAT DEMAND, COOLING 2 ND STAGE.	24VAC DI
4	Y1	DIGITAL INPUT- THERMOSTAT DEMAND, COOLING 1 ST STAGE.	24VAC DI
5	W2	DIGITAL INPUT- THERMOSTAT DEMAND, HEATING 2 ND STAGE.	24VAC DI
5	W1	DIGITAL INPUT- THERMOSTAT DEMAND, HEATING 1 ST STAGE.	24VAC DI
6	G	DIGITAL INPUT- THERMOSTAT DEMAND, BLOWER	24VAC DI
7	A17	DIGITAL INPUT- SMOKE DETECTOR TRIP	24VAC DI
8	A42	DIGITAL INPUT- OPTION 1 (SHUTDOWN) (NORMALLY ENERGIZED)	24VAC DI
PLUG #P201 A138 FOUR STAGE CONTROL BOARD - OUTPUTS TO A55 P110			
1	COM	COMMON	24VAC
2	OCP	DIGITAL OUTPUT- THERMOSTAT DEMAND, OCCUPIED	24VAC DO
3	G	DIGITAL OUTPUT- THERMOSTAT DEMAND, BLOWER	24VAC DO
4	Y1	DIGITAL OUTPUT- THERMOSTAT DEMAND, COOLING 1 ST STAGE.	24VAC DO
5	A17	DIGITAL OUTPUT- SMOKE DETECTOR TRIP	24VAC DO
5	A42	DIGITAL OUTPUT- OPTION 1 (SHUTDOWN) (NORMALLY ENERGIZED)	24VAC DO
6	CLK	DATA OUTPUT – BUS CLOCK	27VDC(1) DATA
7	DATA	DATA OUTPUT – BUS DATA	27VDC(1) DATA

(1) Output is data and difficult to measure. 27VDC is the peak voltage.

I/O

PLUG P194 A133 (DIP SET TO VAV) VAV I/O TB18			
PIN #	LABEL	DESCRIPTION	TYPE
1	D1	DIGITAL INPUT 1 (OPTIONAL BUILDING STATIC PRESSURE S37 FOR STG1 EXHAUST FAN)	24VAC DI
2	D2	DIGITAL INPUT 2 (OPTIONAL BUILDING STATIC PRESSURE S39 FOR STG 2 EXHAUST FAN)	24VAC DI
3	C	COMMON	-
4	RLY-H	24VAC	NO-RELAY
5	RLY-NO	RELAY CONTACT (OUTPUT TO K201, EXHAUST FAN STG 2)	NO-RELAY
6	A1	ANALOG INPUT 1 (SUPPLY DUCT STATIC PRESSURE SENSOR A30)	0-10VDC AI
7	A2	ANALOG INPUT 2 (OPTIONAL BUILDING STATIC PRESSURE SENSOR A34)	0-10VDC AI
8	A3	ANALOG INPUT 3	0-10VDC AI
9	A4	ANALOG INPUT 4	0-10VDC AI
10	GND	ANALOG GROUND	GND
11	AO1	ANALOG OUTPUT 1 (SUPPLY BLOWER VFD A96) OR (BYPASS DAMPER)	0-10VDC AO
12	AO2	ANALOG OUTPUT 2 (OPTIONAL EXHAUST FAN VFD A137)	0-10VDC AO
PLUG P194 A133 (DIP SET TO GP) GENERAL PURPOSE BOARD TB22			
1	D1	DIGITAL INPUT 1	24VAC DI
2	D2	DIGITAL INPUT 2	24VAC DI
3	C	COMMON	-
4	RLY-H	24VAC	NO-RELAY
5	RLY-NO	RELAY CONTACT	NO-RELAY
6	A1	ANALOG INPUT 1	0-10VDC AI
7	A2	ANALOG INPUT 2	0-10VDC AI
8	A3	ANALOG INPUT 3	0-10VDC AI
9	A4	ANALOG INPUT 4	0-10VDC AI
10	GND	ANALOG GROUND	GND
11	AO1	ANALOG OUTPUT 1	0-10VDC AO
12	AO2	ANALOG OUTPUT 2	0-10VDC AO
PLUG P194 A133 (DIP SET TO MGV) MGV I/O TB19			
1	D1	DIGITAL INPUT 1	24VAC DI
2	D2	DIGITAL INPUT 2	24VAC DI
3	C	COMMON	-
4	RLY-H	RELAY CONTACT	NO-RELAY
5	RLY-NO	RELAY CONTACT	NO-RELAY
6	A1	ANALOG INPUT 1	0-10VDC AI
7	A2	ANALOG INPUT 2	0-10VDC AI
8	A3	ANALOG INPUT 3	0-10VDC AI
9	A4	ANALOG INPUT 4	0-10VDC AI
10	GND	ANALOG GROUND	GND
11	AO1	ANALOG OUTPUT 1 (MGV DRIVER A76)	0-10VDC AO
12	AO2	ANALOG OUTPUT 2	0-10VDC AO

Abbreviations

A55	-M1 board. Main RTU control board	HP	-High Pressure
A56	-EM1 board. Economizer control add-on board	HSP	-Heating Setpoint
A57	-C1 board. First compressor add-on board	HT	-Heating
A58	-G1 board. Gas heat add-on board	IAQ	-Indoor air quality. Often synonymous with CO2 level in ppm
A59	-C2 board. Second compressor add-on board	IDE	-Indoor enthalpy. Depends on temperature and humidity
A60	-E1 board. Electric heat add-on board	IMC	-Integrated modular control. M1 with or without attached boards
A61	-HP1 board. Heat pump add-on board	"w.c.	-Inches of Water column
A67	-RH1 board. Humiditrol reheat add-on board	LED	-Light emitting diode. An indicator light. Found either as individual elements or grouped together as segments to form characters
A133	-GP1 board. General purpose add-on board DIP selects 3 functions	LP	-Low Pressure
A138	-FS1 board. Four stage thermostat interface add-on board	LT	-Limit
AI	-Analog Input	M1	-Main IMC board (A55). M1-7 contains IMC software version 5.00 or later
AO	-Analog Output	MGV	-Modulating Gas Valve
BL	-Blower	OAC	-Outdoor air control
C1	-First compressor add-on board (A57)	OAS	-Outdoor air suitable for free cooling
C2	-Second compressor add-on board (A59)	OAT	-Outdoor air temperature
C1	-First Stage cooling	OCP	-Thermostat demand, occupied mode
C2	-Second stage cooling	ODE	-Outdoor enthalpy. Depends on temperature and humidity
C3	-Third stage cooling	PID	-Proportional, Integral and Derivative based control loop
C4	-Fourth stage cooling	PPM	-Part per million (mostly used for CO2 measurements)
CAI	-Combustion Air Inducer	RAP	-Return air pressure
CAVB	-Constant Air Volume with bypass damper	RAT	-Return air temperature
COM	-Electrical Common	RH	-Relative humidity
CL	-Cooling	RH1	-Humiditrol reheat board RH1-1 (A67).
CP1	-Compressor 1	RS	-Reset
CP2	-Compressor 2	RTU	-Roof top unit
CP3	-Compressor 3	RT6	-Discharge air temp. sensor
CP4	-Compressor 4	RT16	-Return air temp. sensor
CSP	-Cooling setpoint	RT17	-Outdoor air temp. sensor
DAC	-Discharge (supply) air control	SMK	-Smoke detection mode (alarm)
DACC	-Discharge (supply) air control cooling	SP	-Setpoint
DACH	-Discharge (supply) air control heating	Stg	-Stage
DAP	-Discharge (supply) air pressure	TB	-Terminal Block
DAT	-Discharge (supply) air temperature	UnOCP	-Unoccupied
DB	-Deadband	W1	-Thermostat demand, heat stage 1
DCV	-Demand Controlled Ventilation	W2	-Thermostat demand, heat stage 2
DI	-Digital Input	W3	-Thermostat demand, heat stage 3
Diff	-Differential	W4	-Thermostat demand, heat stage 4
DIP	-DIP switch	VAC	-Alternating Current Voltage
DO	-Digital Output	VAV	-Variable air volume. Accomplished with a variable frequency drive (VFD)
ECTO	-Electronic Configure To Order. (Control Parameters)	VDC	-Direct Current Voltage
E1	-Electric heat add-on board (A60)	VFD	-Variable frequency drive. An AC inverter used to vary motor speed
EM1	-Economizer control board (A56)	VT	-Ventilation
FAC	-Fresh air cooling control	Y1	-Thermostat demand, cooling stage one
FAH	-Fresh air heating control	Y2	-Thermostat demand, cooling stage two
FAT	-Fresh air tempering control. See FAC and FAH	Y3	-Thermostat demand, cooling stage three
FC	-Free Cooling	Y4	-Thermostat demand, cooling stage four
FS1	-Four stage interface board FS1-1 (A138).	ZAT	-Zone air temperature
G	-Thermostat demand, blower		
GLO	-Global Mode or input (Economizer)		
GP1	-General purpose board GP1-1 (A133)		
H1	-First stage heating		
H2	-Second stage heating		
H3	-Third stage heating		
H4	-Fourth stage heating		
HP1	-Heat pump add-on board (A61)		

IMC M1-7 Version 5.02 Summary Sheet

Pushbutton Basics

Short press - To by-pass delays
Hold - To reset control Fig. 6

UNIT DIP Switch

HP - "ON" for Heat Pump Unit
GAS - "ON" for Gas/Electric Unit
HP & GAS - "OFF" for Electric/Electric Unit
SHIFT - "OFF" during normal unit operation.
1PH - "ON" for single phase units.
All other DIP sw. settings see IMC Components section.

Unit Diagnostic Codes

To recall stored codes:
RECALL DIP - "ON"
Last code will display
Tap button to toggle to previous codes
To erase: Hold button until "0"
RECALL DIP - "OFF" Fig. 15

Display Sensor Readings

TEMP DIP - "ON"
 Outdoor Temp. (RT17)
 Return Air Temp. (RT16)
 Discharge Air Temp. (RT6)
 Zone Temp. (A2)
 CO₂ (ppm/10) (A63)
 OAC Sensor (Volts x 10) (A24)
 Demand Ventilation Damper Position
 Free Cooling Damper Position
 Indoor Relative Humidity (A91)
 Tap button to display next reading.
TEMP DIP - "OFF" Table 38

M1 Software Version

UNIT TEST DIP - "ON"
RECALL DIP - "ON" Fig. 11

ADDRESS DIP Switch

Address DIP is used for setting the unit address when connected to the L Connection network.
Switches add for a total of 31 addresses (1 to 31).
A switch setting of "0" is not valid, even when unit is not networked.
IMC must be reset after changing an address.

Thermostat Input Tests

SHIFT DIP - "ON"
Wait 2 seconds
UNIT TEST DIP - "ON"
Two stage cooling option
c01 = Y1 demand
c10 = c11=Y2 demand
Three stage cooling option
c01 = Y1 demand
c10 = Y2 demand
c11 = Y3 demand
Heat
h01 = W1 demand
h10 = h11=W2 demand
S01 = Smoke Alarm
Tap button to toggle demand option.
Hold button to turn on and off demand.
UNIT TEST - "OFF"
SHIFT - "OFF" Fig. 55

M1-7 Display

E Indicates an incorrect combination of DIP switches.
LAL Low ambient lockout.
LS Load shedding.
dF1 1st stage defrost.
dF2 2nd stage defrost.

To Change ECTO Parameters

ECTO DIP - "ON"
Press button to desired parameter #.
Short press advances parameter #.
Long press advances block #.
SHIFT DIP - "ON" to read value.
Push button once to increase value by 1.
Push button twice to decrease value by 10.
SHIFT DIP - "OFF"
Wait until the parameter # is displayed.
ECTO DIP - "OFF"

Lights

Green blinking (HB) LED is the control "Heartbeat"; indicates normal operation.
Yellow "XMIT" LED is the "Data Transmit" indicator.
Green "BUS" LED indicates network traffic.
Other yellow LED's indicate external thermostat demands G, Y1, Y2, W1, W2, OCP.
Yellow LED on EM1-1 (economizer board - A56) indicates outdoor air is suitable for free cooling. LED blinks if control is in the DCV (IAQ) mode.

Test Control Outputs

UNIT TEST DIP - "ON"
0=Blower
1=Fan 1
2=Fan 2
3=Fan 3
4=Fan 4
5=Fan 5
6=Fan 6
7=Reversing Valve 1
8=Reversing Valve 2
9=Service Output
10=Reheat Solenoid L14
11=Reheat Solenoid L30
12=Exhaust Fan K65
13=Exhaust Fan Stg. 2
14=VAV AO1
15=VAV AO2
16=GP Relay Out
17=GP AO1
18=GP AO2
Digital Outputs:
Tap button to toggle output option.
Hold button to turn output on and off.
UNIT TEST - "OFF"
Analog Outputs:
MODE DIP SHIFT "ON"
Tap button to toggle output value.
Hold button to send value to output.
MODE DIP SHIFT - "OFF"
UNIT TEST - "OFF" Table 35

Defrost Test

UNIT TEST DIP - "ON"
RECALL DIP - "ON"
Start test - Hold pushbutton for long push (5 seconds).
Terminate Test - Press pushbutton.
Note: Defrost will occur on each stage that is operating in heating.

EM1 (Economizer Board)

MIN POS SET - Sets the damper minimum position (0-100% travel).
ENTH SET POINT - Sets the outdoor enthalpy setpoint.
At 50% outdoor RH -
A=73°F, B=70°F, C=67°F, D=63°F
To set or test damper, set both DIP switches "OFF" (DSET). Use MIN POS SET pot to adjust.
For outdoor enthalpy mode, set both DIP switches "ON" (ODE). Fig. 33