



**088 and 100 MODELS**  
**“LCA” PACKAGED COOLING & ELECTRIC HEAT**  
**“LGA” PACKAGED COOLING & GAS HEAT**  
**“LHA” PACKAGED HEAT PUMP**

**LCA/LGA/LHA**

LCA/LGA - 7.5 & 8.5 Ton  
 (26.4 & 29.9 kW)  
 LHA - 7.5 Ton  
 (26.4 kW)

\*Net Cooling Capacity - 76 000 to 84 000 Btuh (22.3 to 24.6 kW) (19 200 to 21 200 kcal)  
 Gas Input Heating Capacity - 73 000 to 160 000 Btuh (21.4 to 46.8 kW) (18 400 to 40 300 kcal)  
 \*Heat Pump Heating Capacity - 77 000 Btuh (22.6 kW) (19 400 kcal)  
 Optional Electric Heat - 5 to 35 kW (4300 to 30 100 kcal)

Bulletin #490079  
 October 1998



**LCA088**  
 (Cooling & Electric Heat)



**LGA088**  
 (Cooling & Gas Heat)



**LHA088**  
 (Heat Pump)

**Table of Contents**

Features .....	Page 2-3	Electrical Data .....	Page 11
Required Options .....	Page 3	Optional Electric Heat Accessories .....	Page 11
Factory Installed Only Options .....	Page 4	Electric Heat Data - LCA088 .....	Page 12
Field and/or Factory Installed Accessories .....	Page 4	Electric Heat Data - LCA100/LHA088 .....	Page 12
Field Installed Only Options .....	Page 5	Cooling Ratings - LCA/LGA Models .....	Page 13-14
Temperature Control Systems .....	Page 6	Cooling & Heating Ratings - LHA Models .....	Page 14
Temperature Control Selection Flowcharts .....	Page 7	Blower Data .....	Page 15-16
Model Number Identification .....	Page 7	Guide Specifications .....	Page 17
High Altitude Derate — LGA Models .....	Page 7	Dimensions - LCA Models .....	Page 18
Specifications - LCA/LGA .....	Page 8	Dimensions - LGA Models .....	Page 19
Specifications - LHA .....	Page 9	Dimensions - LHA Model .....	Page 20
Weight Data .....	Page 10	Dimensions - Accessories .....	Page 21-22
Field Wiring .....	Page 10	Installation Clearances .....	Page 22

<b>FEATURES - ALL MODELS</b>			
<b>Item</b>	<b>LCA/LGA088</b>	<b>LCA/LGA100</b>	<b>LHA088</b>
<b>Air Flow Choice</b> — Bottom (down-flow) or *horizontal (side) supply and return air	Standard	Standard	Standard
<b>Bottom Power Entry</b> — For electrical and gas lines	Standard	Standard	Standard
<b>Cabinet</b> — Heavy gauge galvanized steel, fully insulated, powdered enamel paint finish, large removeable access panels, electrical inlets in cabinet base and electric heat end panel (LCA/LHA only), easy access control area with factory installed controls, low voltage terminal strip, unit lifting holes in base rail	Standard	Standard	Standard
<b>Cabinet Access Panels (Hinged)</b> — 1 compressor/controls access panel, 1 heating area access panel, 1 blower access panel and 1 air filter/economizer access panel hinged with tool-less access handles, gaskets on all edges for tight seal, blower access panel has steel panel inner liner with insulation sandwiched in-between and air filter/economizer access panel is insulated with fiberglass insulation.	Standard	Standard	Standard
<b>Coil Construction</b> — Copper tube construction, ripple-edged enhanced aluminum fins, flared shoulder tubing connections, silver soldered construction, factory tested, evaporator coil face split with separate circuits, indoor coil drain connection extends outside of unit cabinet	Standard	Standard	Standard
<b>Compressor Crankcase Heater(s)</b> - Two on LCA/LGA models and one on LHA models	Standard	Standard	Standard
<b>Filters</b> — Disposable 2 inch (51 mm) pleated commercial grade	Standard	Standard	Standard
<b>Filter Access</b> — Hinged filter door with tool-less access handles	Standard	Standard	Standard
<b>Integrated Modular Control (IMC)</b> — Solid-state board contains all controls and control relays to operate unit <b>Built-in Functions Include:</b> <ul style="list-style-type: none"> <li>- <b>Blower On/Off Delay</b></li> <li>- <b>Built-in Control Parameter Defaults</b>, ensure proper unit operation when power is restored after power failure</li> <li>- <b>Service Relay Output</b></li> <li>- <b>Defrost Control</b></li> <li>- <b>Dirty Filter Switch Input</b></li> <li>- <b>Economizer Control</b>, four modes of operation (outdoor enthalpy, differential enthalpy, temperature and global)</li> <li>- <b>Electric Heat Staging</b>, regulates electric heat during building warm-up</li> <li>- <b>ETM Compatible</b>, various modules (see factory or field installed accessories)</li> <li>- <b>Extensive Unit Diagnostics</b>, (80 diagnostic codes)</li> <li>- <b>Permanent Diagnostic Code Storage</b></li> <li>- <b>Field Changeable Control Parameters</b>, (65 different parameters)</li> <li>- <b>Gas Valve Delay Between First and Second Stage</b></li> <li>- <b>Indoor Air Quality Input</b>, monitors CO<sub>2</sub> levels, adjusts economizer dampers as needed (four modes of operation), requires optional field installed Indoor Air Quality (CO<sub>2</sub>) Sensor</li> <li>- <b>Low Ambient Controls</b> — Allows unit cooling operation down to 0°F (-17.8°C)</li> <li>- <b>Minimum Run Time</b></li> <li>- <b>Night Setback Mode</b>, adjusts setpoint, closes outdoor air dampers and operates blower on demand, may be customized for special requirements</li> <li>- <b>Smoke Alarm Mode</b>, (four modes of operation)</li> <li>- <b>“Strike Three” Low Pressure Control</b>, protects system from low suction pressure while eliminating nuisance faults</li> <li>- <b>Thermostat Bounce Delay</b></li> <li>- <b>Three Digit Display</b>, (Displays: outdoor temperature, supply air temperature, return air temperature, economizer damper position, Indoor Air Quality, control parameters)</li> <li>- <b>Two Stage Thermostat Compatible</b></li> <li>- <b>Warm-up Mode</b>, (four modes of operation)</li> </ul>	Standard	Standard	Standard
<b>ISO 9002 Quality Standard</b> - Developed in accordance with International Standards Organization (ISO) quality standards	Standard	Standard	Standard
<b>Outdoor Coil Fan</b> — PVC coated fan guard furnished	Standard	Standard	Standard
<b>Outdoor Coil Fan Motor</b> — Overload protected, permanently lubricated, equipped with ball bearings, shaft up, wire basket mount	Standard	Standard	Standard
<b>Ratings</b> — Rated test conditions are those included in Air Conditioning and Refrigeration Institute (ARI) Standard 210/240-95 while operating at rated voltage and air volumes. Sound rating number rated at test conditions included in Air Conditioning and Refrigeration Institute (ARI) Standard 270-96.	Standard	Standard	Standard
<b>Supply Air Blower</b> — Belt drive, forward curved blades, blower wheel statically and dynamically balanced, ball bearings, adjustable pulley (allows speed change), blower assembly slides out of unit for servicing	Standard	Standard	Standard
<b>Supply Air Motor (Standard Efficiency)</b> — Overload protected, equipped with ball bearings	Standard	Standard	Standard
<b>Transformer</b> — 70VA transformer with built-in circuit breaker	Standard	Standard	Standard

\*Requires Optional Horizontal Conversion Kit.

<b>FEATURES - LCA MODELS</b>		
Item	LCA088	LCA100
<b>Compressors</b> — Reciprocating type, resiliently mounted on rubber grommets	“S” Models	Not Available
<b>Compressors</b> — Copeland® Compliant Scroll™ for high efficiency, resiliently mounted on rubber grommets	“H” Models	“S” Models
<b>Outdoor Coil Construction</b> — Formed type	Standard	Standard
<b>Refrigeration System</b> — Consists of: compressors, condenser coils and direct drive fans, evaporator coil and belt drive blowers, expansion valves, high capacity driers, high pressure switches, low pressure switches, full refrigerant charge, crankcase heaters, freezestats (prevent coil freeze-up during low ambient operation or loss of air), low ambient switches, independent refrigerant circuits (allows staging)	Standard	Standard
<b>FEATURES - LGA MODELS</b>		
Item	LGA088	LGA100
<b>Compressors</b> — Reciprocating type, resiliently mounted on rubber grommets	“S” Models	Not Available
<b>Compressors</b> — Copeland® Compliant Scroll™ for high efficiency, resiliently mounted on rubber grommets	“H” Models	“S” Models
<b>Fan and Limit Controls</b> — Factory installed, 90 second fan “on” time delay, dual limit controls (primary and secondary) with fixed temperature setting	Standard	Standard
<b>Heat Exchanger</b> — Tubular construction, aluminized steel, life cycle tested	Standard	Standard
<b>Outdoor Coil Construction</b> — Formed type	Standard	Standard
<b>Heating System</b> — Aluminized steel inshot burners, direct spark ignition, electronic flame sensor, redundant automatic dual gas valve with manual shut-off, induced draft blower, flame rollout switch	Standard	Standard
<b>Refrigeration System</b> — Consists of: compressors, condenser coil and direct drive fans, evaporator coil and belt drive blowers, expansion valves, high capacity driers, high pressure switches, low pressure switches, full refrigerant charge, crankcase heaters, freezestats (prevent coil freeze-up during low ambient operation or loss of air) independent refrigerant circuits (allows staging)	Standard	Standard
<b>FEATURES - LHA MODELS</b>		
Item	LHA088S	
<b>Compressors</b> — Copeland® Compliant Scroll™ for high efficiency, resiliently mounted on rubber grommets	Standard	
<b>Defrost Control</b> — Furnished on Integrated Modular Control, defrost control provides a defrost cycle, if needed, every 30 or 60 or 90 minutes (adjustable) of compressor “on” time at outdoor coil temperature below 32°F (0°C). Pressure switch mounted on outdoor coil vapor line terminates defrost cycle.	Standard	
<b>Outdoor Coil Construction</b> — Formed type	Standard	
<b>Refrigeration System</b> — Consists of: compressor, outdoor coil and direct drive fan, indoor coil and belt drive blower, check and expansion valves (indoor and outdoor), high capacity drier, high pressure switch, low pressure switch, reversing valve, defrost control, full refrigerant charge, crankcase heater, freezestat (prevent coil freeze-up during low ambient operation or loss of air), and accumulator.	Standard	
<b>REQUIRED OPTIONS - ITEMS MUST BE ORDERED AND FACTORY INSTALLED</b>		
<b>Air Flow Configuration</b> — specify horizontal or down-flow when ordering base unit		
<b>Supply Air Motor</b> - Standard efficiency, overload protected, equipped with ball bearings (See Blower Data Table for specifications)		
<b>Drive Kit</b> — Order one, see Drive Kit Specifications Table		
<b>Dual Gas Input (LGA Models Only) — Order one:</b>		
73 000 or 110 000 Btuh (21.4 or 32.2 kW) (18 400 or 27 700 kcal) Standard Heat Gas Input		
106 000 or 160 000 Btuh (31.0 or 46.8 kW) (26 700 or 40 300 kcal) High Heat Gas Input		

<b>OPTIONAL ACCESSORIES</b>			
<b>FACTORY INSTALLED ONLY</b>			
Item	LCA/LGA088	LCA/LGA100	LHA088
<b>Condensate Traps</b> — PVC or copper condensate trap factory installed in unit	Factory		
<b>Corrosion Protection</b> — Phenolic epoxy coating, applied to condenser coils (with painted base section) and evaporator coils (with painted evaporator base section and painted blower housings), factory applied to either section or both sections	Factory		
<b>Stainless Steel Heat Exchanger (LGA Models)</b>	Factory	N/A	
<b>Service Valves</b> — Fully serviceable brass valves installed in discharge and liquid lines	Factory	NA	
<b>FACTORY OR FIELD INSTALLED</b>			
Item	LCA/LGA088	LCA/LGA100	LHA088
<b>Electric Heat</b> — Factory or field installed, helix wound nichrome elements, time delay for element staging, individual element limit controls, wiring harness, may be two-stage controlled, requires Fuse Block and Terminal Block (LHA/LCA Models)	See Electric Heat Data Tables Page 13		
<b>Electric Heat Fuse Block</b> — Required with Electric Heat. Mounting screws furnished (LCA/LHA Models)	See Optional Electric Heat Accessories Table (LCA/LHA Models), Page 10		
<b>Electric Heat LTB2 Terminal Block</b> — Required with electric heat			
<b>Control Systems</b> — See pages 6-7 for complete listing	See pages 6-7		
<b>Economizer</b> — Opposing gear driven recirculated air and outdoor air dampers, plug-in connections to unit, nylon bearings, neoprene seals, 24 volt fully modulating spring return motor, adjustable minimum damper position, damper assembly slides in unit, outdoor air hood must be ordered separately (see below), optional down-flow gravity exhaust dampers available (see below), choice of economizer controls (see below) - Net Weight	LAREMD08/10 - 43 lbs. (20 kg)		
<b>Economizer Control Choice</b> — <b>Sensible Control</b> — Furnished on IMC board in unit, uses outdoor air sensor furnished with unit to measure outdoor air temperature and control damper position ( <b>Furnished</b> )  <b>Global Control</b> — Furnished on IMC board in unit, used with Direct Digital Control (DDC) systems, uses global air sensor to control damper position, determines when to use outdoor air for cooling or set damper at minimum position ( <b>Furnished</b> )  <b>Outdoor Enthalpy Control</b> — Adjustable enthalpy sensor, senses outdoor air enthalpy for economizer control, 0 to 100% outdoor air  <b>Differential Enthalpy Control</b> — Two solid-state enthalpy sensors allow selection between outdoor air and return air (whichever has lowest enthalpy)	(16K96) Outdoor (16K97) Differential		
<b>Down-Flow Gravity Exhaust Dampers</b> — Aluminum blade dampers prevent blow back and outdoor air infiltration during off cycle, bird screen furnished - Net Weight	LAGED08/10 - 8 lbs. (4 kg)		
<b>Hood for Down-Flow Gravity Exhaust Dampers</b>	24L15		
<b>Outdoor Air Damper Section</b> — Linked mechanical dampers, 0 to 25% (fixed) outdoor air adjustable, installs in unit for down-flow applications, outdoor air hood must be ordered separately (see below) - Net Weight	<b>Automatic</b> — fully modulating spring return damper motor with plug in connection	LAOADM08/10 - 28 lbs. (13 kg)	
	<b>Manual</b>	LAOAD10/15 - 26 lbs. (12 kg)	
<b>Outdoor Air Hood</b> — Required with LAREMD08/10 Economizer, LAOAD10/15 and LAOADM08/10 Outdoor Air Damper Sections, two cleanable aluminum mesh fresh air filters furnished - Net Weight	LAOAH08/10 - 11 lbs. (5 kg)		
<b>Power Exhaust Fan</b> — Installs in unit for down-flow applications only with economizer option, provides exhaust air pressure relief, interlocked to run when return air dampers are closed and supply air blower is operating, fan runs when outdoor air dampers are 50% open (adjustable), motor is overload protected, requires optional down-flow gravity exhaust dampers (see above)	Model Number - Net Weight	LAPEF08/10 - 28 lbs. (13 kg)	
	Diameter - in. (mm) Number of Blades	20 (508) - 5	
	Total air volume - cfm (m <sup>3</sup> /s)	3500 (1.65) @ 0 in. .wg. (0 Pa)	
	Motor Horsepower (W)	1/3 (249)	
	Total Watts Input	230	
<b>Smoke Detector</b> — Photoelectric type, installed in supply air section or return air section or both sections	70K87 - Supply 70K86 - Return		

**OPTIONAL ACCESSORIES - CONTINUED**

**FIELD INSTALLED ONLY**

Item		LCA/LGA088	LCA/LGA100	LHA088
<b>LPG/Propane Kits (LGA Models Only)</b>		<b>19K52</b>		----
<b>Diffusers</b> Aluminum grilles, large center grille, insulated diffuser box with flanges, hanging rings furnished, interior transition (even air flow), internally sealed (prevents recirculation), adapts to T-bar ceiling grids or plaster ceilings - Net Weight	<b>Step-Down -</b> double deflection louvers	RTD11-95 - 88 lbs. (40 kg)		
	<b>Flush -</b> fixed blade louvers	FD11-95 - 75 lbs. (34 kg)		
<b>Transitions (Supply and Return)</b> — Used with diffusers, installs in roof mounting frame, galvanized steel construction, flanges furnished for duct connection, fully insulated - Net Weight		LASRT08/10 - 30 lbs. (14 kg)		
<b>Horizontal Conversion Kit</b> — Two piece duct cover in kit blocks off unit down-flow supply air opening, horizontal return air opening panel (on unit) is moved to block off down-flow return air opening for horizontal applications.		<b>17L25</b>		
<sup>1</sup> <b>Horizontal Gravity Exhaust Dampers</b> — Aluminum blade dampers prevent blow back and outdoor air infiltration during off cycle, field installed in return air duct, bird screen and hood furnished - Net Weight		LAGEDH10/15 - 8 lbs. (4 kg)		
<b>Indoor Air Quality (CO<sub>2</sub>) Sensor</b> — Monitors CO <sub>2</sub> levels, reports to Integrated Modular Control (IMC) board which adjusts economizer dampers as needed		<b>93J69</b>		
<b>Aspiration box</b> — for duct mounting of Indoor Air Quality Sensor		<b>47N18</b>		
<b>Roof Mounting Frame</b> — Nailer strip furnished, mates to unit, U.S. National Roofing Contractors Approved, shipped knocked down - Net Weight	14 inch (356 mm) height	LARMF08/10-14 - 118 lbs. (54 kg)		
	24 inch (610 mm) height	LARMF08/10-24 - 162 lbs. (74 kg)		
<b>Hail Guards</b> — Constructed of heavy gauge steel, painted to match cabinet, helps protect outdoor coils from hail damage. Not used with Coil Guards		<b>24L54</b>		
<b>Coil Guards</b> — Galvanized steel wire guards to protect outdoor coil. Not used with Hail Guards.		<b>24L55</b>		
IMC Software and PC Interface Kit		<b>86K84</b>		
IMC Software and Manual Only		<b>32K22</b>		
PC Interface Kit Only		<b>28K56</b>		

<sup>1</sup> Field installs in return air duct. Two dampers furnished per order no.

**OPTIONAL DDC TEMPERATURE CONTROL SYSTEMS (FACTORY OR FIELD INSTALLED)**

<b>NOVAR ETM-2050 KIT</b>	—
<b>Electronic Thermostat Module (ETM)/Blower Proving Switch/Return Air Sensor/Discharge Air Sensor/Wiring Harness</b> — Module monitors unit operation from different sensors installed in unit, has outputs for 2 stage heat/2 stage cool, automatic or continuous blower operation, economizer damper operation and night setback, features: day/occupied mode with low enthalpy (outdoor air damper open), high enthalpy (outdoor air damper closed) or night/unoccupied mode (outdoor air damper closed), network communication (RS-485, shielded pair twisted wire), local override (1 to 255 minutes), watchdog function, fail-safe operation, ETM allows units to be “daisy chained” together (up to 31 units) to be operated from one central location with an “executive” type control processor (onsite or offsite), built-in time delays, built-in unit operating defaults, diagnostic LED’s indicate various operating functions, surge suppression protects ETM against lightning or voltage spikes, Blower Proving Switch monitors blower operation and locks out unit in case of blower failure, Return Air Sensor provides input to ETM module to determine heating or cooling operation and number of stages required, Discharge Air Sensor monitors leaving air temperature during unit operation	<b>48K87</b>
<b>Dirty Filter Switch</b> — Senses static pressure increase indicating a dirty filter condition	<b>30K48</b>
<b>Room Temperature Sensor</b> — Provides input to ETM module to determine heating or cooling operation and number of stages required (ordered separately)	<b>97H53</b>
<b>Night Setback Override Switch</b> — Allows momentary override of night setback during unoccupied mode	Field Furnished

**OPTIONAL CONVENTIONAL TEMPERATURE CONTROL SYSTEMS (FIELD INSTALLED)**

<b>System and Component Description</b>	<b>Catalog No.</b>
<b>ELECTRO-MECHANICAL THERMOSTAT</b>	—
<b>Thermostat</b> — Two stage heat & two stage cool with dual temperature levers, subbase choice	<b>13F06</b>
<b>Subbase</b> — Manual system switch (Off-Heat-Auto-Cool), fan switch (Auto-On)	<b>13F17</b>
<b>Subbase</b> — Non-switching	<b>13F16</b>
<b>Night Setback Operation</b> — Order components below	—
<b>Heating Thermostat</b> — Single stage heat	<b>13F12</b>
<b>Subbase</b> — Non-switching	<b>13F16</b>
<b>Time Clock</b> — 7 day operation, indicates day and night periods, 2 hour increments, battery back-up	<b>See Price Book for Selection</b>
<b>Time Clock</b> — 24 hour night setback operation, 15 minute increments, battery back-up	<b>See Price Book for Selection</b>
<b>Blower Proving Switch</b> — Monitors blower operation, locks out unit in case of blower failure	<b>30K49</b>
<b>Dirty Filter Switch</b> — Senses static pressure increase indicating a dirty filter condition	<b>30K48</b>
<b>HONEYWELL T7300 THERMOSTAT</b>	—
<b>Thermostat</b> — Programmable, internal or optional remote temperature sensing (sensor required), touch sensitive keyboard, automatic switching, °F or °C readout, no anticipator, droop/no droop selection, indicator LED’s, hour/day programming, override capabilities, time and operational mode readout, stage status indicators, battery back-up, subbase choice	<b>81G59</b>
<b>Subbase</b> — Selectable staging up to two stage heat & two stage cool, manual system switch (Heat-Off-Auto-Cool), fan switch (Auto-On), indicator LED’s, auxiliary relay output for economizer operation	<b>81G60</b>
<b>Sensor</b> — Room temperature	<b>58C92</b>
<b>Sensor</b> — Room temperature with 3 hour override and setpoint adjustment	<b>86G67</b>
<b>Sensor</b> — Return air temperature	<b>27C40</b>
<b>Blower Proving Switch</b> — Monitors blower operation, locks out unit in case of blower failure	<b>30K49</b>
<b>Dirty Filter Switch</b> — Senses static pressure increase indicating a dirty filter condition	<b>30K48</b>

# COMMERCIAL TEMPERATURE CONTROL SELECTION FLOWCHARTS

## NOVAR ETM-2050

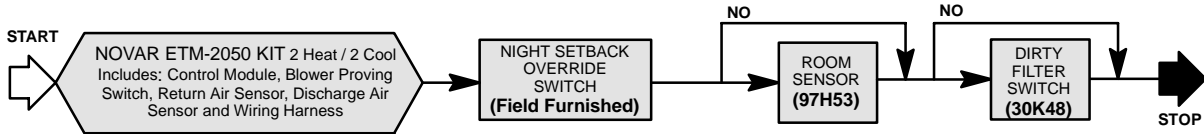

## ELECTRO-MECHANICAL THERMOSTAT

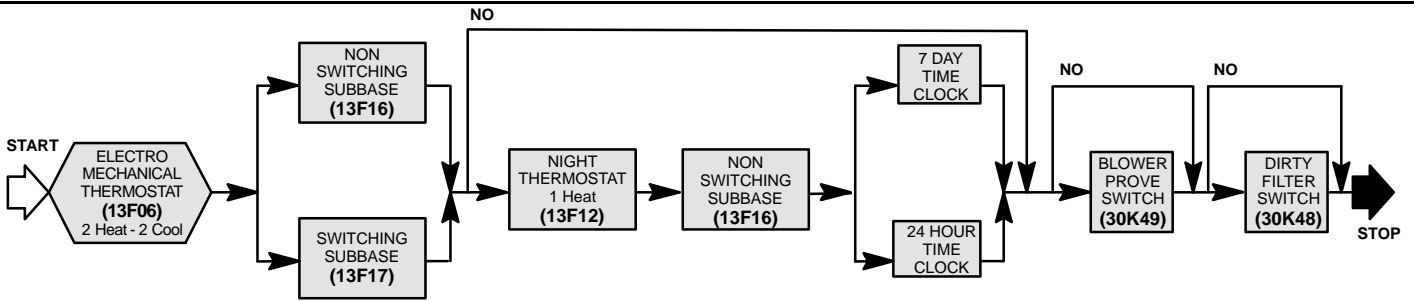

## HONEYWELL T7300 THERMOSTAT

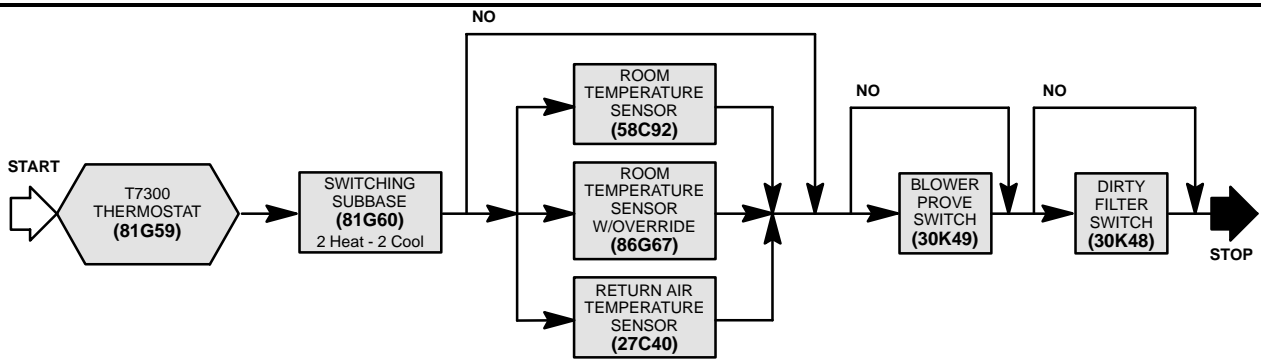

## MODEL NUMBER IDENTIFICATION

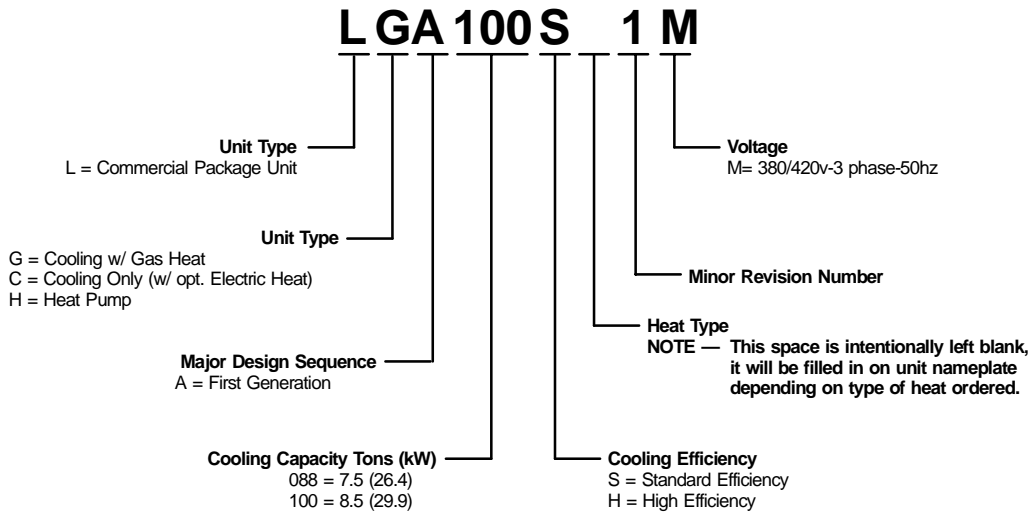

### HIGH ALTITUDE DERATE (LGA MODELS)

Units may be installed at altitudes up to 2000 feet (610 m) above sea level without any modification. At altitudes above 2000 feet (610 m), units must be derated to match gas manifold pressures shown in table below.

NOTE — This is the only permissible derate for these units.

Altitude - ft. (m)	Gas Manifold Pressure - in. w.g. (kPa)
2001 - 3000 (610 - 915)	3.6 (0.90)
3001 - 4000 (915 - 1220)	3.5 (0.87)
4001 - 5000 (1220 - 1525)	3.4 (0.85)
5001 - 6000 (1525 - 1830)	3.3 (0.82)
6001 - 7000 (1830 - 2135)	3.2 (0.80)
7001 - 8000 (2135 - 2440)	3.1 (0.77)

## SPECIFICATIONS - LCA/LGA MODELS

Model Number		LCA/LGA088		LCA/LGA100		
Cooling Ratings	Efficiency type	<b>Standard</b>	<b>High</b>	<b>Standard</b>		
	Gross Cooling Capacity — Btuh (kW) (kcal)	84 900 (24.9) (21 400)	80 500 (23.6) (20 300)	90 400 (26.5) (22 800)		
	☐ Net Cooling Capacity — Btuh (kW) (kcal)	79 000 (23.1) (19 900)	76 000 (22.3) (19 200)	84 000 (24.6) (21 200)		
	Total Unit Power Input (kW)	8.85	7.73	9.54		
	Coefficient of Performance - Output/Input	2.6	2.9	2.6		
	☐ Energy Efficiency Ratio (Btuh/Watt)	8.90	9.80	8.80		
	☑ Integrated Part Load Value (Btuh/Watt)	9.5	10.1	8.9		
☑ Sound Rating Number (db)		86				
Refrigerant Charge Furnished (HCFC-22)	Circuit 1	8 lbs. 0 oz. (3.63 kg)	8 lbs. 8 oz. (3.86 kg)	8 lbs. 8 oz. (3.86 kg)		
	Circuit 2	8 lbs. 0 oz. (3.63 kg)	8 lbs. 8 oz. (3.86 kg)	8 lbs. 8 oz. (3.86 kg)		
Two Stage Heating Capacity (Natural or LPG/Propane Gas (at Sea Level))	Heat Input Type	<b>Standard</b>	<b>High</b>	<b>Standard</b>	<b>High</b>	
	Input (low) — Btuh (kW) (kcal)	73 000 (21.4) (18 400)	106 000 (31.0) (26 700)	73 000 (21.4) (18 400)	106 000 (31.0) (26 700)	
	Output (low) — Btuh (kW) (kcal)	58 000 (17.0) (14 600)	85 000 (24.9) (21 400)	58 000 (17.0) (14 600)	85 000 (24.9) (21 400)	
	Input (High) — Btuh (kW) (kcal)	110 000 (32.2) (27 700)	160 000 (46.8) (40 300)	110 000 (32.2) (27 700)	160 000 (46.8) (40 300)	
	Output (High) — Btuh (kW) (kcal)	88 000 (25.8) (22 200)	128 000 (37.5) (32 300)	88 000 (25.8) (22 200)	128 000 (37.5) (32 300)	
	Thermal Efficiency - Natural Gas/LPG/Propane	80.0%/82.0%				
Gas Supply Connections npt — in. - Natural or LPG/Propane		3/4				
Recommended Gas Supply Pressure — wc. in. (kPa)	Natural	7 (1.7)				
	LPG/Propane	11 (2.7)				
Evaporator Blower and Drive Selection	Blower wheel nominal diameter x width — in. (mm)		(1) 12 x 12 (305 x 305)			
	2 hp (1.5 kW) Motor & Drives	Nominal motor output — hp (kW)		2 (1.5)		
		Voltage & phase		380/420v-50hz-3 phase with neutral		
		(Drive kit #) Rev/Min range		(1) 704-942, (3) 846-1083, (5) 1050-1300		
	3 hp (2.2 kW) Motor & Drives	Nominal motor horsepower (kW)		3 (2.2)		
		Voltage & phase		380/420v-50hz-3 phase with neutral		
(Drive kit #) Rev/Min range		(1) 704-942, (3) 846-1083, (6) 1065-1315				
Evaporator Coil	Net face area — sq. ft. (m <sup>2</sup> )		9.72 (0.90)			
	Tube diameter — in. (mm) & Number of rows		3/8 (9.5) — 3			
	Fins per inch (m)		14 (551)			
	Drain connection number & size — in. (mm) fpt		(1) - 1 (25.4)			
	Expansion device type		Balanced Port Thermostatic Expansion Valve, removeable power head			
Condenser Coil	Net face area — sq. ft. (m <sup>2</sup> )		23.78 (2.21)			
	Tube diameter — in. (mm) & Number of rows		3/8 (9.5) — 2			
	Fins per inch (m)		20 (787)			
Condenser Fans	Diameter — in. (mm) & Number of blades		(1) — 24 (610) - 3			
	Total air volume — cfm (m <sup>3</sup> /s)		4415 (2.08)			
	Motor horsepower (W)		1/2 (373)			
	Motor Rev/Min		895			
	Total Motor watts		420			
Filters (furnished)	Type of filter		Disposable Commercial Grade Pleated			
	Number and size — in. (mm)		(4) 18 x 20 x 2 (457 x 508 x 51)			
Electrical characteristics		380/420v-50hz-3 phase with neutral				

☐ Rated test conditions are those included in Air Conditioning and Refrigeration Institute (ARI) Standard 360-86 while operating at rated voltage and air volumes. **Cooling Ratings:** 95°F (35°C) outdoor air temperature and 80°F (27°C) db/67°F (19°C) wb entering evaporator air; minimum external duct static pressure.

☑ Integrated Part Load Value rated at 80°F (27°C) outdoor air temperature.

☑ Sound rating number rated at test conditions included in Air Conditioning and Refrigeration Institute (ARI) Standard 270-96.

NOTE — Net capacity includes evaporator blower motor heat deduction. Gross capacity does not include evaporator blower motor heat deduction.



SPECIFICATIONS - LHA MODEL			
Model Number		LHA088S	
Cooling Ratings	Efficiency Type		
	Standard		
	Gross Cooling Capacity — Btuh (kW) (kcal)		
	83 200 (24.4) (21 000)		
	Net Cooling Capacity — Btuh (kW) (kcal)		
	79 000 (23.1) (19 900)		
High Temperature Heating Ratings	Total Unit Power Input (kW)		
	8.5		
	Coefficient of Performance - Output/Input		
	2.5		
	Energy Efficiency Ratio (Btuh/Watt)		
9.30			
Low Temperature Heating Ratings	Total Heating Capacity — Btuh (kW) (kcal)		
	77 000 (22.6) (19 400)		
	Total Unit Power Input (kW)		
7.0			
Sound Rating Number (db)	Coefficient of Performance - Output/Input		
	3.2		
	2.1		
Refrigerant Charge Furnished (HCFC-22)		86	
17 lbs. 0 oz. (7.71 kg)			
Indoor Blower and Drive Selection	Blower wheel nominal diameter x width — in. (mm)		
	12 x 12 (305 x 305)		
	2 hp (1.5 kW) Motor & Drives	Nominal motor output — hp (kW)	
		2 (1.5)	
		Voltage & phase	
	380/420v-50hz-3 phase with neutral		
(Drive Kit #) rev/min range			
(1) 704-942, (3) 846-1083, (5) 1050-1300			
3 hp (2.2 kW) Motor & Drives	Nominal motor horsepower (kW)		
	3 (2.2)		
	Voltage & phase		
380/420v-50hz-3 phase with neutral			
(Drive Kit #) rev/min range			
(1) 704-942, (3) 846-1083, (6) 1065-1315			
Indoor Coil	Net face area — sq. ft. (m <sup>2</sup> )		
	9.72 (.90)		
	Tube diameter — in. (mm) & Number of rows		
	3/8 (9.5) — 3		
	Fins per inch (m)		
14 (551)			
Drain connection Number & size — in. (mm) fpt			
(1) 1 (25.4)			
Expansion device type		Balanced Port Thermostatic Expansion Valve, removeable power head	
Outdoor Coil	Net face area — sq. ft. (m <sup>2</sup> )		
	23.78 (2.21)		
	Tube diameter — in. (mm) & Number of rows		
	3/8 (9.5) — 2		
Fins per inch (m)			
20 (787)			
Expansion device type		Balanced Port Thermostatic Expansion Valve, removeable power head	
Outdoor Fans	Diameter — in. (mm) & Number of blades		
	24 (610) - 3		
	Total Air volume — cfm (m <sup>3</sup> /s)		
	4415 (2.08)		
	Motor horsepower (W)		
1/2 (373)			
Motor rev/min			
895			
Total Motor watts			
420			
Filters (furnished)	Type of filter		
	Disposable Commercial Grade Pleated		
Number and size — in. (mm)			
(4) 18 x 20 x 2 (457 x 508 x 51)			
Electrical characteristics		380/420v-50hz-3 phase with neutral	

Rated test conditions are those included in Air Conditioning and Refrigeration Institute (ARI) Standard 340-86 while operating at rated voltage and air volumes.

**Cooling Ratings**— 95°F (35°C) outdoor air temperature and 80°F (27°C) db/67°F (19°C) wb entering indoor coil air.

**High Temperature Heating Ratings**— 47°F (8°C) db/43°F (6°C) wb outdoor air temperature and 70°F (21°C) entering indoor coil air.

**Low Temperature Heating Ratings**— 17°F (-8°C) db/15°F (-9°C) wb outdoor air temperature and 70°F (21°C) entering indoor coil air.

Sound rating number rated at test conditions included in Air Conditioning and Refrigeration Institute (ARI) Standard 270-96.

NOTE — Net capacity includes evaporator blower motor heat deduction. Gross capacity does not include evaporator blower motor heat deduction.

## WEIGHT DATA - ALL MODELS

Model Number	Description	Weight	
		lbs.	kg
<b>Net Weights</b>			
LCA088S	Net weight (Base unit)	1065	483
LCA088H	Net weight (Base unit)	1065	483
LCA100S	Net weight (Base unit)	1105	502
LGA088S	Net weight (Base unit with low fire heat exchanger)	1125	510
LGA100S	Net weight (Base unit with low fire heat exchanger)	1165	528
LGA088H	Net weight (Base unit with low fire heat exchanger)	1125	510
LHA088S	Net weight (Base unit)	980	445
<b>Shipping Weights (Add Factory Installed Options Weights To Base Unit Weights For Total Shipping Weight)</b>			
LCA088S	Base unit	1140	501
LCA088H	Base unit	1140	501
LCA100S	Base unit	1180	535
LHA088S	Base unit	1055	478
LCA/LHA Models Only	Electric Heat (add to Base unit)	See Electric Heat Rating Tables	
LGA088S	Base unit with low fire heat exchanger	1200	544
LGA088H	Base unit with low fire heat exchanger	1200	544
LGA100S	Base unit with low fire heat exchanger	1240	562
LGA Models Only	High Fire Heat Exchanger (add to Base unit)	30	14
All Models	Economizer (add to Base unit)	66	30
	Outdoor Air Damper (add to Base unit)	40	18
	Power Exhaust (add to Base unit)	28	13
	LTL Packaging (less than truck load) (add to Base unit)	95	43

## FIELD WIRING

### NOVAR ETM-2050 CONTROL SYSTEM

- A — Three wire power (See Electrical Data Table)
- B — RS-485 shielded pair twisted wire
- C — Four wire low voltage
- D — Two wire low voltage

— Field wiring not furnished —

NOTE — All wiring must conform to local electrical codes.

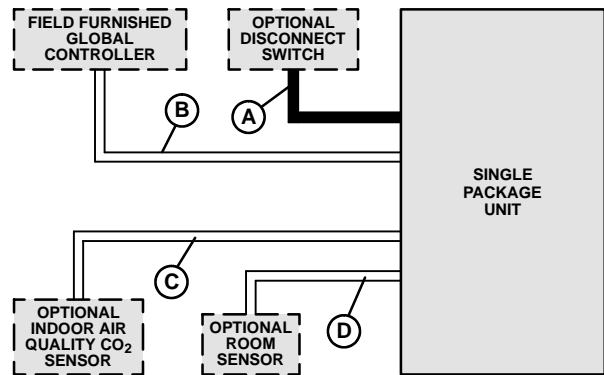

### ELECTRO-MECHANICAL, ELECTRONIC OR HONEYWELL T7300 THERMOSTAT CONTROL SYSTEM

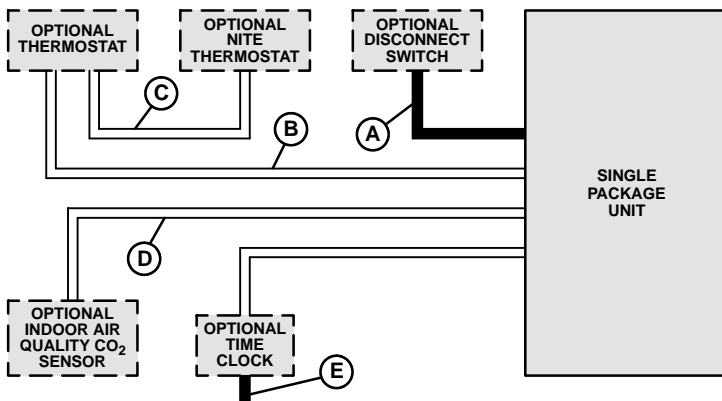

- A — Three wire power (See Electrical Data Table)
- B — Six wire low voltage (Electro-Mechanical)  
Seven wire low voltage (Electronic)  
Nine wire low voltage (Honeywell T7300)  
Ten wire low voltage (Honeywell T7300 with Service LED)
- C — Two wire low voltage (Electro-Mechanical Only)
- D — Four wire low voltage (All Systems)
- E — Two wire power

— Field wiring not furnished —

NOTE — All wiring must conform to local electrical codes.

<b>ELECTRICAL DATA - LCA/LGA088</b>						
Model Number			LCA/LGA088			
Line voltage data — 50 Hz — 3 phase with neutral			380/420v			
Efficiency type			Standard (S)		High (H)	
Compressors (2)	Rated load amps each (total)		7.1 (14.2)		6.4 (12.8)	
	Locked rotor amps each (total)		46 (92.0)		44.0 (88.0)	
Outdoor Fan Motor	Full load amps		1.5		1.5	
	Locked rotor amps		3.0		3.0	
Indoor Blower Motor	Motor Output	hp	2	3	2	3
		kW	1.5	2.2	1.5	2.2
	Full load amps		3.0	4.7	3.0	4.7
	Locked rotor amps		22.1	27.0	22.1	27.0
Optional Power Exhaust Fan	(Number) Horsepower (W)		(1) 1/3 (249)			
	Full load amps		1.3		1.3	
	Locked rotor amps		2.4		2.4	

Refer to local electrical codes to determine wire, fuse and disconnect size requirements. Use wires suitable for at least 167°F (75°).  
Service Factor = 1.15

<b>ELECTRICAL DATA - LCA/LGA100S &amp; LHA088S</b>						
Model Number			LCA/LGA100S		LHA088S	
Line voltage data — 50 Hz — 3 phase with neutral			380/420v		380/420v	
Efficiency Type			Standard (S)			
Compressors (2 - LCA/LGA) (1 - LHA)	Rated load amps each (total)		6.7 (13.4)		14.7 total	
	Locked rotor amps each (total)		47.5 (95.0)		95.0 total	
Outdoor Fan Motor	Full load amps		1.5		1.5	
	Locked rotor amps		3.0		3.0	
Indoor Blower Motor	Motor Output	hp	2	3	2	3
		kW	1.5	2.2	1.5	2.2
	Full load amps		3.0	4.7	3.0	4.7
	Locked rotor amps		22.1	27.0	22.1	27.0
Optional Power Exhaust Fan	(Number) Horsepower (W)		(1) 1/3 (249)			
	Full load amps		1.3		1.3	
	Locked rotor amps		2.4		2.4	

Refer to local electrical codes to determine wire, fuse and disconnect size requirements. Use wires suitable for at least 167°F (75°).  
Service Factor = 1.15

<b>OPTIONAL ELECTRIC HEAT ACCESSORIES - LCA/LHA MODELS</b>					
<b>UNIT FUSE BLOCKS WITH ELECTRIC HEAT</b>					
Unit Model Number		LCA088S	LCA088H	LCA100S	LHA088S
Electric Heat	Model Number	EHA (see Electric Heat Data tables for additional information)			
	kW Input Range	7.5 - 15 - 30 - 45			
Unit Fuse Block (3 phase)	Without Power Exhaust Fans	56K52	56K52	56K52	25K09
		25K08	56K52	56K52	25K09
	With Power Exhaust Fans	56K52	56K52	56K52	25K09
		56K52	56K52	56K52	25K09
<b>LTB2 ELECTRIC HEAT TERMINAL BLOCK</b>					
LTB2-175 (30K75) 175 amps (Required For Units <u>Without</u> Disconnect/Circuit Breaker But <u>With</u> Single Point Power Source)					
LTB2 Terminal Block (3 phase)		30K75	30K75	30K75	30K75

**NOTE** — Terminal Block is factory installed in units with factory installed electric heat without disconnect/circuit breaker but with single point power source.

**OPTIONAL ELECTRIC HEAT DATA (REQUIRES UNIT FUSE BLOCK AND TERMINAL BLOCK)**

kW Size	Electric Heat Model Number (see footnote) Net Weight	Number of Elements	Volts Input	Total Heating Capacity - 50hz			Total Unit & Electric Heat (With Power Exhaust) Minimum Circuit Ampacity (A)	
				kW	kcal	Btuh	2 hp (1.5 kW)	3 hp (2.2 kW)
<b>LCA088 SIZE</b>								
5	EHA100-7.5 (16L09) 31 lbs. (14 kg)	1	380	4.7	4040	16 000	22 (S) / 21 (H)	24 (S) / 22 (H)
		1	400	5.2	4480	17 800		
		1	420	5.7	4935	19 600		
12	EHA150-15 (16L12) 31 lbs. (14 kg)	1	380	9.4	8090	32 100	26 (S) / 26 (H)	28 (S) / 28 (H)
		1	400	10.4	8970	35 600		
		1	420	11.5	9880	39 200		
20	EHA100-22.5 (32L96) 38 lbs. (17 kg)	*2	380	14.1	12 100	48 100	35 (S) / 35 (H)	38 (S) / 38 (H)
		*2	400	15.6	13 400	53 200		
		*2	420	17.2	14 800	58 700		
25	EHA150-30 (16L15) 38 lbs. (17 kg)	*2	380	18.8	16 200	64 200	45 (S) / 45 (H)	47 (S) / 47 (H)
		*2	400	20.8	17 900	71 100		
		*2	420	23.0	19 800	78 400		
35	EHA150-45 (16L18) 42 lbs. (19 kg)	*2	380	28.2	24 300	96 300	65 (S) / 65 (H)	67 (S) / 67 (H)
		*2	400	31.2	26 900	106 700		
		*2	420	34.4	26 600	117 600		
<b>LCA100 SIZE</b>								
5	EHA100-7.5 (16L09) 31 lbs. (14 kg)	1	380	4.7	4040	16 000	21 (S)	23 (S)
		1	400	5.2	4480	17 800		
		1	420	5.7	4935	19 600		
12	EHA150-15 (16L12) 31 lbs. (14 kg)	1	380	9.4	8090	32 100	26 (S)	28 (S)
		1	400	10.4	8970	35 600		
		1	420	11.5	9880	39 200		
20	EHA100-22.5 (32L96) 38 lbs. (17 kg)	*2	380	14.1	12 100	48 100	35 (S)	38 (S)
		*2	400	15.6	13 400	53 200		
		*2	420	17.2	14 800	58 700		
25	EHA150-30 (16L15) 38 lbs. (17 kg)	*2	380	18.8	16 200	64 200	45 (S)	47 (S)
		*2	400	20.8	17 900	71 100		
		*2	420	23.0	19 800	78 400		
35	EHA150-45 (16L18) 42 lbs. (19 kg)	*2	380	28.2	24 300	96 300	65 (S)	67 (S)
		*2	400	31.2	26 900	106 700		
		*2	420	34.4	26 600	117 600		
<b>LHA088 SIZE</b>								
5	EHA100-7.5 (16L09) 31 lbs. (14 kg)	1	380	4.7	4040	16 000	35 (S)	36 (S)
		1	400	5.2	4480	17 800		
		1	420	5.7	4935	19 600		
12	EHA150-15 (16L12) 31 lbs. (14 kg)	1	380	9.4	8090	32 100	44 (S)	46 (S)
		1	400	10.4	8970	35 600		
		1	420	11.5	9880	39 200		
20	EHA100-22.5 (32L96) 38 lbs. (17 kg)	*2	380	14.1	12 100	48 100	54 (S)	56 (S)
		*2	400	15.6	13 400	53 200		
		*2	420	17.2	14 800	58 700		
25	EHA150-30 (16L15) 38 lbs. (17 kg)	*2	380	18.8	16 200	64 200	64 (S)	66 (S)
		*2	400	20.8	17 900	71 100		
		*2	420	23.0	19 800	78 400		
35	EHA150-45 (16L18) 42 lbs. (19 kg)	*2	380	28.2	24 300	96 300	83 (S)	86 (S)
		*2	400	31.2	26 900	106 700		
		*2	420	34.4	26 600	117 600		

NOTE - (H) indicates high efficiency units. (S) indicates standard efficiency units.

\*May be used with two stage control.

NOTE - Fuse block must be ordered extra. Factory installed heaters will have the fuse block factory installed. Fuse block must be installed in unit with field installed heaters. Also requires LTB2 Terminal Block.

# COOLING RATINGS - LCA/LGA MODELS

NOTE - For Temperatures and Capacities not shown in tables, see bulletin — Cooling Unit Rating Table Correction Factor Data in Miscellaneous Engineering Data section.

## LCA/LGA 088S - STANDARD EFFICIENCY - ONE COMPRESSOR RUNNING

Entering Wet Bulb Temperature	Total Air Volume		Outdoor Air Temperature Entering Outdoor Coil																							
			18°C (65°F)					24°C (75°F)					29°C (85°F)					35°C (95°F)								
			Total Cooling Capacity		Comp Motor kW Input	Sensible To Total Ratio (S/T)			Total Cooling Capacity		Comp Motor kW Input	Sensible To Total Ratio (S/T)			Total Cooling Capacity		Comp Motor kW Input	Sensible To Total Ratio (S/T)			Total Cooling Capacity		Comp Motor kW Input	Sensible To Total Ratio (S/T)		
						Dry Bulb						Dry Bulb						Dry Bulb						Dry Bulb		
m³/s	cfm	kW	kBtu/h	24°C 75°F	27°C 80°F	29°C 85°F	kW	kBtu/h	24°C 75°F	27°C 80°F	29°C 85°F	kW	kBtu/h	24°C 75°F	27°C 80°F	29°C 85°F	kW	kBtu/h	24°C 75°F	27°C 80°F	29°C 85°F	kW	kBtu/h	24°C 75°F	27°C 80°F	29°C 85°F
17°C (63°F)	1.13	2400	13.2	45.1	2.66	.64	.78	.93	12.6	42.9	2.94	.66	.80	.96	12.0	40.9	3.22	.67	.83	.98	11.3	38.7	3.50	.68	.86	1.00
	1.41	3000	13.8	47.1	2.67	.69	.86	1.00	13.1	44.8	2.97	.71	.89	1.00	12.5	42.6	3.26	.73	.92	1.00	11.8	40.4	3.55	.75	.95	1.00
	1.70	3600	14.2	48.6	2.68	.75	.94	1.00	13.6	46.4	2.99	.77	.97	1.00	13.0	44.2	3.30	.79	.99	1.00	12.3	42.1	3.60	.82	1.00	1.00
19°C (67°F)	1.13	2400	14.2	48.3	2.68	.51	.62	.74	13.5	46.1	2.98	.51	.63	.76	12.8	43.8	3.29	.52	.64	.78	12.2	41.5	3.58	.53	.66	.81
	1.41	3000	14.7	50.2	2.69	.53	.66	.82	14.0	47.8	3.01	.54	.68	.85	13.3	45.4	3.32	.55	.70	.88	12.6	43.0	3.63	.56	.72	.91
	1.70	3600	15.1	51.5	2.69	.56	.72	.90	14.4	49.0	3.02	.57	.74	.93	13.7	46.6	3.34	.58	.76	.96	12.9	44.0	3.66	.60	.79	.99
22°C (71°F)	1.13	2400	15.2	51.8	2.69	.39	.49	.59	14.5	49.4	3.02	.39	.50	.61	13.8	47.0	3.35	.39	.51	.62	13.1	44.6	3.67	.39	.51	.63
	1.41	3000	15.7	53.7	2.70	.40	.52	.64	15.0	51.2	3.04	.40	.53	.65	14.2	48.6	3.38	.40	.54	.67	13.5	46.0	3.71	.41	.55	.69
	1.70	3600	16.1	55.0	2.70	.40	.55	.69	15.4	52.4	3.05	.41	.56	.71	14.6	49.7	3.40	.41	.57	.74	13.8	47.0	3.74	.42	.59	.77

## LCA/LGA 088S - STANDARD EFFICIENCY - ALL COMPRESSORS RUNNING

Entering Wet Bulb Temperature	Total Air Volume		Outdoor Air Temperature Entering Outdoor Coil																							
			27°C (80°F)					35°C (95°F)					43°C (110°F)					52°C (125°F)								
			Total Cooling Capacity		Comp Motor kW Input	Sensible To Total Ratio (S/T)			Total Cooling Capacity		Comp Motor kW Input	Sensible To Total Ratio (S/T)			Total Cooling Capacity		Comp Motor kW Input	Sensible To Total Ratio (S/T)			Total Cooling Capacity		Comp Motor kW Input	Sensible To Total Ratio (S/T)		
						Dry Bulb						Dry Bulb						Dry Bulb						Dry Bulb		
m³/s	cfm	kW	kBtu/h	24°C 75°F	27°C 80°F	29°C 85°F	kW	kBtu/h	24°C 75°F	27°C 80°F	29°C 85°F	kW	kBtu/h	24°C 75°F	27°C 80°F	29°C 85°F	kW	kBtu/h	24°C 75°F	27°C 80°F	29°C 85°F	kW	kBtu/h	24°C 75°F	27°C 80°F	29°C 85°F
17°C (63°F)	1.13	2400	24.2	82.6	6.14	.69	.83	.96	22.4	76.4	6.94	.71	.86	1.00	20.6	70.2	7.72	.73	.90	1.00	18.7	63.7	8.42	.77	.96	1.00
	1.41	3000	25.3	86.2	6.22	.73	.90	1.00	23.4	79.8	7.06	.77	.95	1.00	21.5	73.4	7.86	.80	.99	1.00	19.7	67.3	8.66	.85	1.00	1.00
	1.70	3600	26.1	89.1	6.26	.79	.98	1.00	24.3	82.9	7.16	.83	1.00	1.00	22.6	77.0	8.03	.87	1.00	1.00	20.7	70.8	8.86	.93	1.00	1.00
19°C (67°F)	1.13	2400	25.9	88.5	6.26	.54	.66	.79	24.0	82.0	7.12	.55	.68	.82	22.0	75.2	7.95	.57	.71	.86	20.0	68.2	8.72	.59	.74	.92
	1.41	3000	26.9	91.9	6.32	.57	.71	.86	24.9	84.9	7.22	.58	.74	.91	22.8	77.8	8.07	.60	.78	.96	20.6	70.4	8.86	.63	.83	1.00
	1.70	3600	27.6	94.3	6.36	.60	.76	.94	25.5	87.1	7.28	.62	.80	.98	23.4	79.7	8.16	.64	.85	1.00	21.2	72.2	8.96	.67	.90	1.00
22°C (71°F)	1.13	2400	27.9	95.1	6.38	.41	.52	.63	25.8	88.1	7.31	.41	.53	.65	23.7	81.0	8.20	.41	.55	.68	21.5	73.4	9.04	.42	.57	.72
	1.41	3000	28.9	98.5	6.42	.42	.55	.69	26.7	91.1	7.40	.42	.57	.71	24.5	83.5	8.32	.43	.59	.75	22.2	75.6	9.17	.44	.61	.79
	1.70	3600	29.5	100.8	6.46	.43	.58	.74	27.3	93.1	7.45	.44	.60	.78	24.9	85.1	8.39	.45	.63	.82	22.6	77.0	9.26	.46	.66	.88

## LCA/LGA 088H - HIGH EFFICIENCY - ONE COMPRESSOR RUNNING

Entering Wet Bulb Temperature	Total Air Volume		Outdoor Air Temperature Entering Outdoor Coil																							
			18°C (65°F)					24°C (75°F)					29°C (85°F)					35°C (95°F)								
			Total Cooling Capacity		Comp Motor kW Input	Sensible To Total Ratio (S/T)			Total Cooling Capacity		Comp Motor kW Input	Sensible To Total Ratio (S/T)			Total Cooling Capacity		Comp Motor kW Input	Sensible To Total Ratio (S/T)			Total Cooling Capacity		Comp Motor kW Input	Sensible To Total Ratio (S/T)		
						Dry Bulb						Dry Bulb						Dry Bulb						Dry Bulb		
m³/s	cfm	kW	kBtu/h	24°C 75°F	27°C 80°F	29°C 85°F	kW	kBtu/h	24°C 75°F	27°C 80°F	29°C 85°F	kW	kBtu/h	24°C 75°F	27°C 80°F	29°C 85°F	kW	kBtu/h	24°C 75°F	27°C 80°F	29°C 85°F	kW	kBtu/h	24°C 75°F	27°C 80°F	29°C 85°F
17°C (63°F)	1.13	2400	11.9	40.7	2.07	.67	.83	.98	11.5	39.4	2.33	.68	.84	1.00	11.1	38.0	2.62	.69	.86	1.00	10.7	36.6	2.96	.71	.88	1.00
	1.41	3000	12.4	42.3	2.08	.73	.92	1.00	12.0	40.9	2.34	.74	.94	1.00	11.6	39.5	2.64	.76	.96	1.00	11.2	38.1	2.97	.78	.98	1.00
	1.70	3600	12.8	43.7	2.09	.80	.99	1.00	12.4	42.4	2.36	.81	1.00	1.00	12.0	41.1	2.65	.84	1.00	1.00	11.6	39.7	2.99	.85	1.00	1.00
19°C (67°F)	1.13	2400	12.7	43.4	2.09	.53	.65	.79	12.3	42.0	2.35	.53	.66	.80	11.9	40.5	2.65	.54	.67	.82	11.4	38.9	2.98	.55	.68	.84
	1.41	3000	13.1	44.8	2.11	.56	.70	.88	12.7	43.3	2.37	.56	.72	.90	12.3	41.8	2.66	.57	.73	.92	11.8	40.1	3.00	.58	.75	.95
	1.70	3600	13.4	45.8	2.12	.59	.77	.97	13.0	44.2	2.38	.60	.79	.99	12.5	42.7	2.67	.61	.81	1.00	12.0	41.0	3.01	.62	.83	1.00
22°C (71°F)	1.13	2400	13.6	46.3	2.12	.40	.51	.63	13.1	44.8	2.38	.40	.52	.64	12.7	43.2	2.68	.40	.52	.65	12.2	41.6	3.01	.40	.53	.66
	1.41	3000	14.0	47.7	2.13	.41	.55	.68	13.5	46.1	2.39	.41	.55	.70	13.0	44.5	2.69	.41	.56	.71	12.5	42.7	3.03	.42	.57	.73
	1.70	3600	14.2	48.6	2.14	.42	.58	.74	13.8	47.0	2.40	.42	.59	.76	13.3	45.3	2.70	.43	.60	.78	12.7	43.5	3.04	.43	.61	.80

## LCA/LGA 088H - HIGH EFFICIENCY - ALL COMPRESSORS RUNNING

Entering Wet Bulb Temperature	Total Air Volume		Outdoor Air Temperature Entering Outdoor Coil																							
			27°C (80°F)					35°C (95°F)					43°C (110°F)					52°C (125°F)								
			Total Cooling Capacity		Comp Motor kW Input	Sensible To Total Ratio (S/T)			Total Cooling Capacity		Comp Motor kW Input	Sensible To Total Ratio (S/T)			Total Cooling Capacity		Comp Motor kW Input	Sensible To Total Ratio (S/T)			Total Cooling Capacity		Comp Motor kW Input	Sensible To Total Ratio (S/T)		
						Dry Bulb						Dry Bulb						Dry Bulb						Dry Bulb		
m³/s	cfm	kW	kBtu/h	24°C 75°F	27°C 80°F	29°C 85°F	kW	kBtu/h	24°C 75°F	27°C 80°F	29°C 85°F	kW	kBtu/h	24°C 75°F	27°C 80°F	29°C 85°F	kW	kBtu/h	24°C 75°F	27°C 80°F	29°C 85°F	kW	kBtu/h	24°C 75°F	27°C 80°F	29°C 85°F
17°C (63°F)	1.13	2400	22.7	77.6	5.09	.74	.89	1.00	21.5	73.4	6.08	.76	.91	1.00	20.1	68.7	7.29	.78	.94	1.00	18.7	63.7	8.76	.81	.98	1.00
	1.41	3000	23.7	80.7	5.11	.80	.96	1.00	22.4	76.3	6.12	.82	.99	1.00	21.1	71.9	7.34	.85	1.00	1.00	19.7	67.2	8.80	.89	1.00	1.00
	1.70	3600	24.6	83.8	5.15	.86	1.00	1.00	23.3	79.6	6.15	.89	1.00	1.00	22.0	75.2	7.37	.92	1.00	1.00	20.5	70.1	8.84	.96	1.00	1.00
19°C (67°F)	1.13	2400	24.3	82.8	5.13	.58	.71	.85	22.9	78.1	6.14	.59	.73	.88	21.4	73.1	7.36	.60	.76	.91	19.8	67.5	8.82	.62	.79	.95
	1.41	3000	25.0	85.3	5.17	.61	.78	.93	23.6	80.5	6.17	.63	.80	.96	22.0	75.2	7.39	.64	.83	.99	20.4	69.5	8.86	.67	.87	1.00
	1.70	3600	25.6	87.2	5.19	.65	.84	1.00	24.1	82.2	6.20	.67	.87	1.00	22.5	76.9	7.41	.69	.90	1.00	20.9	71.3	8.88	.72	.94	1.00
22°C (71°F)	1.13	2400	25.8	88.2	5.19	.43	.56	.69	24.4	83.4	6.20	.43	.57	.71	22.9	78.0	7.43	.44	.59	.73	21.2	72.2	8.90	.44	.60	.76
	1.41	3000	26.6	90.8	5.23	.44	.60	.76	25.1	85.6	6.23	.45	.61	.78	23.5	80.1	7.45	.46	.63	.81	21.7	73.9	8.92	.46	.66	.85
	1.70	3600	27.1	92.6	5.23	.46	.64	.82	25.6	87.2	6.24	.46	.66	.85	23.9	81.4	7.47	.47	.68	.88	22.0	75.1	8.94	.49		

## COOLING RATINGS - LCA/LGA MODELS

NOTE - For Temperatures and Capacities not shown in tables, see bulletin — Cooling Unit Rating Table Correction Factor Data in Miscellaneous Engineering Data section.

### LCA/LGA 100S - STANDARD EFFICIENCY - ONE COMPRESSOR RUNNING

Entering Wet Bulb Temperature	Total Air Volume		Outdoor Air Temperature Entering Outdoor Coil																							
			18°C (65°F)						24°C (75°F)						29°C (85°F)						35°C (95°F)					
			Total Cooling Capacity		Comp Motor kW Input	Sensible To Total Ratio (S/T)			Total Cooling Capacity		Comp Motor kW Input	Sensible To Total Ratio (S/T)			Total Cooling Capacity		Comp Motor kW Input	Sensible To Total Ratio (S/T)			Total Cooling Capacity		Comp Motor kW Input	Sensible To Total Ratio (S/T)		
						Dry Bulb						Dry Bulb						Dry Bulb						Dry Bulb		
			m³/s	cfm	kW	kBtu/h	24°C 75°F	27°C 80°F	29°C 85°F	kW	kBtu/h	Input	24°C 75°F	27°C 80°F	29°C 85°F	kW	kBtu/h	Input	24°C 75°F	27°C 80°F	29°C 85°F	kW	kBtu/h	Input	24°C 75°F	27°C 80°F
17°C (63°F)	1.28	2720	13.7	46.6	2.63	.67	.82	.97	13.2	45.2	2.91	.68	.83	.99	12.8	43.6	3.23	.69	.85	1.00	12.3	41.9	3.60	.70	.87	1.00
	1.60	3400	14.2	48.4	2.68	.72	.91	1.00	13.7	46.9	2.96	.73	.93	1.00	13.2	45.2	3.28	.75	.95	1.00	12.7	43.5	3.65	.77	.97	1.00
	1.92	4080	14.6	49.9	2.72	.79	.98	1.00	14.2	48.4	3.00	.80	1.00	1.00	13.7	46.9	3.33	.82	1.00	1.00	13.3	45.3	3.70	.84	1.00	1.00
19°C (67°F)	1.28	2720	14.5	49.6	2.71	.53	.65	.78	14.1	48.1	2.99	.53	.65	.79	13.6	46.4	3.31	.54	.66	.81	13.0	44.5	3.68	.54	.68	.83
	1.60	3400	15.0	51.3	2.75	.55	.70	.87	14.5	49.6	3.03	.56	.71	.89	14.0	47.8	3.36	.57	.73	.91	13.5	45.9	3.73	.58	.74	.93
	1.92	4080	15.4	52.4	2.78	.59	.76	.95	14.9	50.7	3.07	.59	.78	.97	14.3	48.8	3.39	.60	.80	.99	13.7	46.9	3.76	.61	.82	1.00
22°C (71°F)	1.28	2720	15.5	52.9	2.80	.40	.51	.62	15.0	51.2	3.08	.40	.51	.63	14.5	49.4	3.41	.40	.52	.64	13.9	47.5	3.78	.40	.53	.65
	1.60	3400	16.0	54.5	2.84	.41	.54	.68	15.4	52.7	3.13	.41	.55	.69	14.9	50.8	3.46	.41	.56	.70	14.3	48.8	3.83	.42	.57	.72
	1.92	4080	16.3	55.6	2.87	.42	.58	.73	15.7	53.7	3.16	.42	.58	.75	15.2	51.7	3.49	.43	.60	.77	14.5	49.6	3.86	.43	.61	.79

### LCA/LGA 100S - STANDARD EFFICIENCY - ALL COMPRESSORS RUNNING

Entering Wet Bulb Temperature	Total Air Volume		Outdoor Air Temperature Entering Outdoor Coil																							
			27°C (80°F)						35°C (95°F)						43°C (110°F)						52°C (125°F)					
			Total Cooling Capacity		Comp Motor kW Input	Sensible To Total Ratio (S/T)			Total Cooling Capacity		Comp Motor kW Input	Sensible To Total Ratio (S/T)			Total Cooling Capacity		Comp Motor kW Input	Sensible To Total Ratio (S/T)			Total Cooling Capacity		Comp Motor kW Input	Sensible To Total Ratio (S/T)		
						Dry Bulb						Dry Bulb						Dry Bulb						Dry Bulb		
			m³/s	cfm	kW	kBtu/h	24°C 75°F	27°C 80°F	29°C 85°F	kW	kBtu/h	Input	24°C 75°F	27°C 80°F	29°C 85°F	kW	kBtu/h	Input	24°C 75°F	27°C 80°F	29°C 85°F	kW	kBtu/h	Input	24°C 75°F	27°C 80°F
17°C (63°F)	1.28	2720	25.6	87.4	6.14	.70	.85	.99	24.2	82.5	7.21	.72	.88	1.00	22.6	77.2	8.47	.74	.92	1.00	21.1	71.9	9.97	.77	.96	1.00
	1.60	3400	26.6	90.8	6.24	.76	.94	1.00	25.1	85.7	7.31	.78	.97	1.00	23.6	80.5	8.60	.81	1.00	1.00	22.2	75.7	10.11	.85	1.00	1.00
	1.92	4080	27.5	93.8	6.33	.82	1.00	1.00	26.1	89.2	7.41	.85	1.00	1.00	24.6	84.0	8.73	.89	1.00	1.00	23.1	78.8	10.27	.93	1.00	1.00
19°C (67°F)	1.28	2720	27.3	93.0	6.30	.55	.68	.81	25.7	87.6	7.37	.56	.70	.84	24.0	82.0	8.65	.57	.72	.88	22.4	76.3	10.17	.58	.74	.92
	1.60	3400	28.1	95.9	6.39	.58	.73	.91	26.5	90.4	7.47	.59	.76	.94	24.7	84.4	8.75	.61	.79	.98	23.0	78.4	10.27	.63	.83	1.00
	1.92	4080	28.7	98.0	6.45	.61	.80	.98	27.0	92.2	7.53	.63	.83	1.00	25.3	86.2	8.83	.65	.87	1.00	23.5	80.1	10.35	.68	.91	1.00
22°C (71°F)	1.28	2720	29.1	99.2	6.49	.41	.53	.65	27.4	93.4	7.57	.41	.54	.67	25.6	87.4	8.87	.42	.56	.69	23.8	81.3	10.41	.42	.57	.72
	1.60	3400	29.9	101.9	6.58	.42	.57	.71	28.1	96.0	7.67	.43	.58	.74	26.3	89.6	8.97	.43	.60	.77	24.4	83.2	10.51	.44	.62	.80
	1.92	4080	30.4	103.8	6.64	.43	.61	.78	28.6	97.7	7.73	.44	.62	.81	26.7	91.2	9.05	.45	.64	.85	24.8	84.6	10.57	.46	.67	.89

## COOLING/HEATING RATINGS - LHA MODELS

NOTE - For Temperatures and Capacities not shown in tables, see bulletin — Cooling Unit Rating Table Correction Factor Data in Miscellaneous Engineering Data section.

### LHA088S FULL LOAD COOLING CAPACITY

Entering Wet Bulb Temperature	Total Air Volume		Outdoor Air Temperature Entering Outdoor Coil																							
			27°C (80°F)						35°C (95°F)						43°C (110°F)						52°C (125°F)					
			Total Cooling Capacity		Comp Motor kW Input	Sensible To Total Ratio (S/T)			Total Cooling Capacity		Comp Motor kW Input	Sensible To Total Ratio (S/T)			Total Cooling Capacity		Comp Motor kW Input	Sensible To Total Ratio (S/T)			Total Cooling Capacity		Comp Motor kW Input	Sensible To Total Ratio (S/T)		
						Dry Bulb						Dry Bulb						Dry Bulb						Dry Bulb		
			m³/s	cfm	kW	kBtu/h	24°C 75°F	27°C 80°F	29°C 85°F	kW	kBtu/h	Input	24°C 75°F	27°C 80°F	29°C 85°F	kW	kBtu/h	Input	24°C 75°F	27°C 80°F	29°C 85°F	kW	kBtu/h	Input	24°C 75°F	27°C 80°F
17°C (63°F)	1.13	2400	23.6	80.6	5.74	.72	.87	.98	22.4	76.3	6.80	.74	.89	1.00	21.0	71.7	8.04	.76	.92	1.00	19.5	66.7	9.46	.79	.95	1.00
	1.41	3000	24.5	83.6	5.78	.78	.94	1.00	23.2	79.2	6.85	.80	.96	1.00	21.8	74.5	8.10	.83	.98	1.00	20.4	69.6	9.53	.86	1.00	1.00
	1.70	3600	25.3	86.2	5.82	.83	.99	1.00	24.0	81.8	6.91	.86	1.00	1.00	22.6	77.2	8.17	.89	1.00	1.00	21.2	72.3	9.61	.92	1.00	1.00
19°C (67°F)	1.13	2400	25.1	85.5	5.81	.57	.70	.83	23.7	80.8	6.90	.58	.72	.86	22.2	75.8	8.14	.59	.74	.88	20.6	70.3	9.57	.61	.77	.92
	1.41	3000	25.8	88.0	5.86	.60	.76	.91	24.4	83.2	6.94	.61	.78	.93	22.8	77.9	8.20	.63	.81	.96	21.2	72.2	9.62	.65	.84	.99
	1.70	3600	26.3	89.9	5.90	.63	.81	.97	24.9	84.9	6.98	.65	.84	.99	23.3	79.4	8.24	.67	.87	1.00	21.6	73.6	9.67	.69	.91	1.00
22°C (71°F)	1.13	2400	26.7	91.1	5.91	.42	.55	.68	25.2	86.1	7.00	.43	.56	.69	23.7	80.7	8.26	.43	.57	.72	22.0	74.9	9.71	.44	.59	.74
	1.41	3000	27.4	93.5	5.97	.44	.59	.73	25.9	88.3	7.04	.44	.60	.76	24.2	82.6	8.32	.45	.62	.78	22.4	76.5	9.75	.46	.64	.82
	1.70	3600	27.9	95.3	5.99	.45	.62	.79	26.3	89.7	7.09	.45	.64	.82	24.6	83.9	8.35	.46	.66	.85	22.7	77.6	9.79	.47	.69	.89

### LHA088S - HEATING CAPACITY

Indoor Coil Air Volume 21°C db (70°F db)		Air Temperature Entering Outdoor Coil														
		18°C (65°F)				7°C (45°F)		minus 4°C (25°F)		minus 15°C (5°F)		minus 28°C (minus 15°F)				
		Total Heating Capacity		Comp. Motor kW Input	Total Heating Capacity		Comp. Motor kW Input	Total Heating Capacity		Comp. Motor kW Input	Total Heating Capacity		Comp. Motor kW Input	Total Heating Capacity		Comp. Motor kW Input
kW	kBtu/h	kW	kBtu/h		kW	kBtu/h		kW	kBtu/h		kW	kBtu/h				
1.13	2400	28.1	95.9	6.20	21.3	72.7	5.69	14.3	48.9	5.15	8.9	30.4	4.64	4.5	15.2	3.48
1.41	3000	28.6	97.6	5.88	21.8	74.4	5.37	14.8	50.6	4.83	9.4	32.1	4.33	5.0	16.9	3.16
1.70	3600	29.2	99.8	5.64	22.4	76.6	5.13	15.5	52.8	4.59	10.1	34.3	4.08	5.6	19.1	2.92

## BLOWER DATA - BASE UNIT

**BLOWER TABLE INCLUDES RESISTANCE FOR LCA088 BASE UNIT ONLY WITH DRY INDOOR COIL AND AIR FILTERS IN PLACE.**

**FOR ALL UNITS ADD:**

- 1 - Wet indoor coil air resistance of selected unit.
- 2 - Any factory installed options air resistance (heat section, economizer, etc.)
- 3 - Any field installed accessories air resistance (duct resistance, diffuser, etc.)

Then determine from blower table blower motor output and drive required.

See Page 16 for wet coil and option/accessory air resistance data and blower motors and drives.

**MINIMUM AIR VOLUME REQUIRED FOR USE WITH OPTIONAL ELECTRIC HEAT**

- LCA/LHA models require 3000 cfm (1.41 m<sup>3</sup>/s) minimum air with electric heat in horizontal applications
- LCA/LHA models require 2600 cfm (1.23 m<sup>3</sup>/s) minimum air with electric heat in downflow applications

***BOLD ITALICS INDICATE FIELD FURNISHED DRIVE.***

Air Volume cfm (m <sup>3</sup> /s)	Total Static Pressure - Inches Water Gauge (Pa)																				
	0.20 (50)		0.40 (100)		0.60 (150)		0.80 (200)		1.00 (250)		1.20 (300)		1.40 (350)		1.60 (400)		1.80 (450)		2.00 (495)		
	Rev/ Min	BHP (kW)	Rev/ Min	BHP (kW)	Rev/ Min	BHP (kW)	Rev/ Min	BHP (kW)	Rev/ Min	BHP (kW)	Rev/ Min	BHP (kW)	Rev/ Min	BHP (kW)	Rev/ Min	BHP (kW)	Rev/ Min	BHP (kW)	Rev/ Min	BHP (kW)	Rev/ Min
2000 (0.95)	<b>625</b>	<b>0.40</b> <i>(.30)</i>	725	0.55 (0.41)	820	0.70 (0.52)	905	0.90 (0.67)	990	1.10 (0.82)	1065	1.30 (0.97)	1140	1.55 (1.16)	1215	1.85 (1.38)	1285	2.20 (1.64)	<b>1350</b>	<b>2.50</b> <i>(1.87)</i>	
2200 (1.05)	<b>670</b>	<b>0.50</b> <i>(.37)</i>	760	0.65 (0.48)	850	0.80 (0.60)	930	1.00 (0.75)	1010	1.20 (0.90)	1085	1.45 (1.08)	1155	1.70 (1.27)	1225	1.95 (1.45)	1290	2.25 (1.68)	<b>1355</b>	<b>2.60</b> <i>(1.94)</i>	
2400 (1.15)	715	0.65 (.48)	800	0.80 (0.60)	880	0.95 (0.71)	960	1.15 (0.86)	1030	1.35 (1.01)	1105	1.60 (1.19)	1170	1.80 (1.34)	1240	2.10 (1.57)	1305	2.40 (1.79)	<b>1365</b>	<b>2.70</b> <i>(2.01)</i>	
2600 (1.25)	760	0.80 (.60)	840	0.95 (0.71)	915	1.10 (0.82)	990	1.30 (0.97)	1060	1.50 (1.12)	1125	1.75 (1.31)	1195	2.00 (1.49)	1255	2.25 (1.68)	<b>1320</b>	<b>2.55</b> <i>(1.90)</i>	<b>1380</b>	<b>2.85</b> <i>(2.13)</i>	
2800 (1.35)	805	1.00 (.75)	880	1.15 (0.86)	955	1.30 (0.97)	1020	1.50 (1.12)	1090	1.70 (1.27)	1155	1.95 (1.45)	1215	2.20 (1.64)	1280	2.45 (1.83)	<b>1335</b>	<b>2.70</b> <i>(2.01)</i>	<b>1395</b>	<b>3.05</b> <i>(2.28)</i>	
3000 (1.40)	855	1.20 (.90)	925	1.35 (1.01)	990	1.50 (1.12)	1055	1.70 (1.27)	1120	1.95 (1.45)	1185	2.15 (1.60)	1245	2.40 (1.79)	1300	2.65 (1.98)	<b>1360</b>	<b>2.95</b> <i>(2.20)</i>	<b>1415</b>	<b>3.25</b> <i>(2.42)</i>	
3200 (1.50)	900	1.40 (1.04)	965	1.60 (1.19)	1030	1.75 (1.31)	1095	2.00 (1.49)	1155	2.20 (1.64)	1215	2.45 (1.83)	1270	2.65 (1.98)	<b>1330</b>	<b>2.95</b> <i>(2.20)</i>	<b>1385</b>	<b>3.25</b> <i>(2.42)</i>	<b>1435</b>	<b>3.50</b> <i>(2.61)</i>	
3400 (1.60)	950	1.70 (1.27)	1010	1.85 (1.38)	1075	2.05 (1.53)	1130	2.25 (1.68)	1190	2.50 (1.87)	1245	2.70 (2.01)	1300	2.95 (2.20)	<b>1355</b>	<b>3.25</b> <i>(2.42)</i>	<b>1410</b>	<b>3.50</b> <i>(2.61)</i>	<b>1460</b>	<b>3.80</b> <i>(2.83)</i>	
3600 (1.70)	995	1.95 (1.45)	1055	2.15 (1.60)	1115	2.35 (1.75)	1170	2.55 (1.90)	1225	2.80 (2.09)	1280	3.05 (2.28)	<b>1335</b>	<b>3.30</b> <i>(2.46)</i>	<b>1385</b>	<b>3.55</b> <i>(2.65)</i>	<b>1440</b>	<b>3.85</b> <i>(2.87)</i>	<b>1490</b>	<b>4.15</b> <i>(3.10)</i>	
3800 (1.80)	1045	2.30 (1.72)	1100	2.45 (1.83)	1160	2.70 (2.01)	1210	2.90 (2.16)	1265	3.15 (2.35)	<b>1320</b>	<b>3.40</b> <i>(2.54)</i>	<b>1370</b>	<b>3.65</b> <i>(2.72)</i>	<b>1420</b>	<b>3.95</b> <i>(2.95)</i>	<b>1470</b>	<b>4.25</b> <i>(3.17)</i>	<b>1515</b>	<b>4.50</b> <i>(3.36)</i>	
4000 (1.90)	1095	2.65 (1.98)	1150	2.85 (2.13)	1200	3.05 (2.28)	1255	3.30 (2.46)	<b>1305</b>	<b>3.55</b> <i>(2.65)</i>	<b>1355</b>	<b>3.80</b> <i>(2.83)</i>	<b>1405</b>	<b>4.05</b> <i>(3.02)</i>	<b>1450</b>	<b>4.30</b> <i>(3.21)</i>	<b>1500</b>	<b>4.60</b> <i>(3.43)</i>	<b>1545</b>	<b>4.90</b> <i>(3.66)</i>	

### FACTORY INSTALLED DRIVE KIT SPECIFICATIONS

Motor Outputs				Rev/Min Range			
Nominal hp	Maximum hp	Nominal kW	Maximum kW	Drive 1	Drive 3	Drive 5	Drive 6
2	2.30	1.5	1.7	704 - 942	846 - 1083	1050 - 1300	----
3	3.45	2.2	2.6	704 - 942	846 - 1083	----	1065 - 1315

## BLOWER DATA - ALL MODELS

### FACTORY INSTALLED OPTIONS/FIELD INSTALLED ACCESSORY AIR RESISTANCE

Air Volume		Total Resistance — inches water gauge (Pa)				
		Wet Indoor Coil	Gas Heat Exchanger (LGA Models)		Electric Heat (LCA/LHA Models)	Economizer
			Low Fire	High Fire		
cfm	m <sup>3</sup> /s					
2000	.90	0.06 (15)	0.05 (12)	0.08 (20)	0.13	0.03 (7)
2200	1.05	0.07 (17)	0.08 (20)	0.13 (32)	0.15	0.04 (10)
2400	1.20	0.09 (22)	0.10 (25)	0.16 (40)	0.16	0.05 (12)
2600	1.25	0.10 (25)	0.14 (35)	0.23 (57)	0.17	0.05 (12)
2800	1.30	0.11 (27)	0.15 (37)	0.25 (62)	0.18	0.06 (15)
3000	1.40	0.12 (30)	0.19 (47)	0.32 (80)	0.20	0.06 (15)
3200	1.50	0.14 (35)	0.23 (57)	0.39 (97)	0.24	0.07 (17)
3400	1.60	0.15 (37)	0.26 (65)	0.43 (107)	0.26	0.08 (20)
3600	1.70	0.17 (42)	0.30 (75)	0.50 (124)	0.30	0.09 (22)
3800	1.80	0.18 (45)	0.32 (80)	0.53 (132)	0.33	0.10 (25)
4000	1.90	0.19 (47)	0.36 (90)	0.60 (149)	0.35	0.11 (27)

### CEILING DIFFUSER AIR RESISTANCE

Unit Size	Air Volume		Total Resistance — inches water gauge (Pa)			
			RTD11 Step-Down Diffuser			FD11 Flush Diffuser
			2 Ends Open	1 Side 2 Ends Open	All Ends & Sides Open	
cfm	m <sup>3</sup> /s					
088 & 100 Models	2400	1.20	.21 (52)	.18 (.45)	.15 (37)	.14 (35)
	2600	1.25	.24 (60)	.21 (52)	.18 (45)	.17 (42)
	2800	1.30	.27 (67)	.24 (60)	.21 (52)	.20 (50)
	3000	1.40	.32 (80)	.29 (72)	.25 (62)	.25 (62)
	3200	1.50	.41 (102)	.37 (92)	.32 (80)	.31 (77)
	3400	1.60	.50 (124)	.45 (112)	.39 (97)	.37 (92)
	3600	1.70	.61 (152)	.54 (134)	.48 (119)	.44 (109)
	3800	1.80	.73 (182)	.63 (157)	.57 (142)	.51 (127)

### POWER EXHAUST FANS PERFORMANCE

Return Air System Static Pressure		Air Volume Exhausted	
in. w.g.	Pa	cfm	m <sup>3</sup> /s
0	0	4200	2.00
0.05	12	3970	1.90
0.10	25	3750	1.75
0.15	37	3520	1.65
0.20	50	3300	1.55
0.25	62	3080	1.45
0.30	75	2860	1.35
0.35	87	2640	1.25

### CEILING DIFFUSER AIR THROW DATA

Model Number	Air Volume		*Effective Throw Range			
			RTD11 Step-Down		FD11 Flush	
	cfm	m <sup>3</sup> /s	ft.	m	ft.	m
088 & 100 Models	3000	1.40	27 - 33	8 - 10	25 - 30	8 - 9
	3375	1.60	30 - 37	9 - 11	28 - 34	9 - 10
	3750	1.75	34 - 41	10 - 12	31 - 38	9 - 12

\*Throw is the horizontal or vertical distance an airstream travels on leaving the outlet or diffuser before the maximum velocity is reduced to 50 ft. (15 m) per minute. Four sides open.



## GUIDE SPECIFICATIONS - ALL MODELS

Prepared for the guidance of architects, consulting engineers and mechanical contractors.

**General** — Furnish and install a single package air to air DX mechanical cooling system, cooling and gas fired heating system or heat pump system, complete with automatic controls. The single package unit shall be a standard product of a firm regularly engaged in the manufacture of heating-cooling equipment.

The installed weight shall not be more than \_\_\_\_\_ lbs. (kg). Entire unit shall have a width of not more than \_\_\_\_\_ inches (mm), a depth of not more than \_\_\_\_\_ inches (mm) and an overall height of not more than \_\_\_\_\_ inches (mm). The equipment shall be shipped completely factory assembled, precharged, piped and wired internally ready for field connections. In addition, manufacturer shall test operate system at the factory before shipment.

**Air Distribution** — Equipment shall be capable of bottom (down-flow) or side (horizontal) handling of conditioned air. Horizontal air shall require optional horizontal conversion kit. All air distribution ducts shall be fiberglass or \_\_\_\_\_ ga. galvanized steel insulated with \_\_\_\_\_ inch (mm) thick lb./ft.<sup>3</sup> (kg/m<sup>3</sup>) density fiberglass or equivalent.

**Integrated Modular Control (IMC)** — Solid state control board shall be provided to operate unit. Built-in functions shall include: blower on/off delay, built-in control parameter defaults, service relay output, defrost control, dirty filter switch input, economizer control, electric heat staging, ETM compatible, unit diagnosis, diagnostics code storage, gas valve delay between stages, indoor air quality input, low ambient controls, minimum run time, night setback mode, smoke alarm mode, low pressure control, thermostat bounce delay, three digit display, two stage thermostat compatible and warm up mode.

**Cooling System** — The total certified cooling capacity shall not be less than \_\_\_\_\_ Btuh (kW) with an indoor coil air volume of \_\_\_\_\_ cfm (m<sup>3</sup>/s), an entering wet bulb air temperature of \_\_\_\_\_ °F (°C), an entering dry bulb air temperature of \_\_\_\_\_ °F (°C) and an outdoor coil entering temperature of \_\_\_\_\_ °F (°C). The compressor power input shall not exceed \_\_\_\_\_ kW at these conditions.

The coils shall be non-ferrous construction with aluminum fins mechanically bonded to durable copper tubes. Coils shall be pressure leak tested. Coil face area shall be not less than \_\_\_\_\_ sq. ft. (m<sup>2</sup>) (indoor coil) and \_\_\_\_\_ sq. ft. (m<sup>2</sup>) (outdoor coil). Outdoor coils shall be slab coil construction.

Compressor(s) shall be resiliently mounted, have overload protection and crankcase heater(s). The refrigeration system shall have discharge suction and liquid line gauge ports, high pressure switch(es), low pressure switch(es), drier(s), freestat, defrost control (LHA), check and expansion valve (LHA), reversing valve (LHA), accumulator (LHA) and full refrigerant charge. Optional service valves shall be available (LCA/LGA only). All models shall have low ambient operation down to 0°F (-17.7°C).

**Heating System (LGA Models)** — The heating capacity output shall be \_\_\_\_\_ Btuh (kW) with a gas input of \_\_\_\_\_ Btuh (kW).

Tubular heat exchanger and inshot type gas burners shall be constructed of aluminumized steel. Controls shall consist of direct spark ignition, electronic flame sensor controls, flame rollout switch, limit controls and automatic redundant dual gas valve with staging control and combustion air proving switch on induced draft blower. Unit shall be available for use with LPG/propane as an option. Heat exchanger shall be removable for servicing. Complete service access shall be provided for controls and wiring.

**Heating System (LHA Models)** — The total certified heating capacity shall not be less than \_\_\_\_\_ Btuh (kW) with an indoor coil air volume of \_\_\_\_\_ cfm (m<sup>3</sup>/s), an entering dry bulb temperature of \_\_\_\_\_ °F (°C) and an outdoor coil entering air temperature of \_\_\_\_\_ °F (°C). The total compressor power input shall not exceed \_\_\_\_\_ kW at the above conditions.

**Cabinet** — Shall be galvanized steel with a powdered enamel paint finish electrostatically bonded to the metal. Cabinet panels where conditioned air is handled shall be fully insulated to prevent sweating and minimize sound. Openings shall be provided for power connection entry. Indoor coil condensate drain extended outside cabinet shall be provided. Lifting holes shall be provided for rigging. Bottom power and gas (LGA) entry shall be furnished.

**Service Access** — Cabinet panels shall be hinged with tool-less access for compressor/heating/controls, blower and air filter/economizer compartments.

**Supply Air Blower** — Centrifugal supply air blower shall have ball bearings and adjustable belt drive. Blower assembly shall slide out of unit for servicing. Motor mount base shall permit ease of motor changeover and belt tension adjustment. Blower wheel shall be statically and dynamically balanced. Blower shall be capable of delivering \_\_\_\_\_ cfm (m<sup>3</sup>/s) at an external static pressure of \_\_\_\_\_ inches water gauge (Pa) requiring \_\_\_\_\_ bhp (W) and \_\_\_\_\_ Rev/Min.

**Outdoor Coil Fan** — Direct drive propeller type outdoor coil fan shall discharge vertically and be direct driven by a \_\_\_\_\_ hp (W) motor. Fan motor shall have ball bearings and be permanently lubricated and inherently protected. Fan shall have a safety guard.

**Air Filters** — Disposable 2 inch (51 mm) thick pleated filters furnished shall have not less than \_\_\_\_\_ sq. ft. (m<sup>2</sup>) of free area.

## OPTIONAL ACCESSORIES

**Additive Electric Heaters (LCA/LHA Models)** — The certified total heating capacity output shall be \_\_\_\_\_ Btuh with \_\_\_\_\_ kW input at \_\_\_\_\_ volts power supply.

Electric heaters shall be available for factory or field installation. Heating elements shall be nichrome bare wire exposed directly to the air stream. Time delays shall bring the elements on and off in sequence with a time delay between each element. Limit controls shall provide overload and short circuit protection.

**Unit Fuse Block (LCA/LHA Models)** — Shall be required for units with single point power supply and electric heat.

**Terminal Block (LCA/LHA Models)** — Shall be required for units without disconnect switch but with single point power supply and electric heat.

**Roof Mounting Frame** — Furnish and install a steel roof mounting frame for bottom discharge and return air duct connection. It shall mate to the bottom perimeter of the equipment. When flashed into the roof it shall make a unit mounting curb and provide weatherproof duct connection and entry into the conditioned area. Height of frame shall be \_\_\_\_\_ inches (mm). Flashing shall be the responsibility of the roofing contractor.

**Economizer Section** — Furnish and install economizer complete with recirculated air dampers, outside air dampers and controls. Low leakage dampers shall ride in nylon bearings. The economizer section shall provide for the introduction of outdoor air for minimum ventilation and free cooling. Integrated economizer control shall allow compressors to cycle for additional cooling, as needed. Damper actuator shall be opposing gear driven, 24 volt, fully modulating design. Plug-in control board (on unit IMC board) shall consist of adjustable minimum positioner, enthalpy setpoint and DIP switches for setting type of control logic used. Economizer control options shall consist of sensible temperature, global, outdoor enthalpy and differential enthalpy (outdoor and return air). Optional outdoor air hood (required) with filters shall be galvanized steel with a powdered enamel paint finish electrostatically bonded to the metal. Economizer shall be available for factory or field installation.

**Gravity Exhaust Dampers** — Pressure operated dampers shall be available for factory or field installation. Extruded aluminum dampers shall prevent blow-back and outdoor air infiltration during off cycle.

**Power Exhaust Fan** — Shall be available for all models with economizer (down-flow applications only). Direct drive propeller type fan shall exhaust air through optional gravity exhaust damper (required). Motor shall be overload protected. Fan shall be factory or field installed between economizer and gravity exhaust dampers.

**Horizontal Conversion Kit** — Shall be available for all models to provide duct covers to block off unit down-flow supply air opening, horizontal return air opening panel (on unit) is moved to block off down-flow return air opening for horizontal applications.

**Horizontal Gravity Exhaust Dampers** — Pressure operated dampers shall be available for field installation in the return air duct. Extruded aluminum dampers shall prevent blow-back and outdoor air infiltration during off cycle.

**Outdoor Air Damper Section** — Optional outdoor dampers shall be available to provide outdoor air requirements of up to 25%. Models shall be available for manual or automatic operation. Dampers shall be opposing gear driven design. Motorized damper section shall install internal to the unit. Optional outdoor air hood (required) with filters shall be galvanized steel with a powdered enamel paint finish electrostatically bonded to the metal. Dampers shall be available for factory or field installation.

**Ceiling Diffusers** — Furnish and install a (flush or stepdown) optional combination ceiling supply and return air diffuser. It shall be capable of not less than \_\_\_\_\_ ft. (m) radius of effective throw. Supply and return transitions shall be available, for field installation in the roof mounting frame, to provide duct connection to the diffuser.

**Control Systems** — Shall provide a selection of control systems to automatically operate the mechanical equipment through the heating or cooling and ventilating cycles as required.

**Coil Guards** — Furnish and install galvanized steel coil guards.

**Hail Guards** — Furnish and install heavy gauge, painted steel hail guards.

**Dirty Filter Switch** — Furnish and install pressure switch that indicates dirty filter, relays information to Integrated Modular Control.

**Blower Proving Switch** — Furnish and factory install air pressure switch to monitor blower operation.

**High Efficiency Blower Motor** — Furnish and factory install high efficiency blower motor.

**Indoor Air Quality Sensor** — Furnish and field install sensor to monitor CO<sub>2</sub> levels, relays information to Integrated Module Control which adjusts economizer dampers proportionately to the pollutant level.

**Service Valves (LCA/LGA)** — Furnish and factory install fully serviceable brass service valves in discharge and liquid lines. Shall allow refrigerant pump down to high side of system for servicing of low side.

**Smoke Detectors** — Furnish and factory install photoelectric type smoke detector in either or both return air section and supply air section.

**Corrosion Protection** — Furnish and factory apply phenolic epoxy coating to either or both of the following:

Outdoor coils with painted outdoor base section. Indoor coil with painted indoor base section and painted blower housings.

# LCA DIMENSIONS - INCHES (MM)

LCA088 & 100 UNITS SHOWN WITH  
 OPTIONAL ECONOMIZER DAMPERS, POWER EXHAUST FANS, CONVENIENCE OUTLET, UNIT DISCONNECT  
 CORNER WEIGHTS — lbs. (kg)

Model Number	AA		BB		CC		DD	
	lbs.	kg	lbs.	kg	lbs.	kg	lbs.	kg
LCA088 Base Unit	286	130	232	105	242	110	305	138
LCA088 Max. Unit	329	149	258	117	267	121	327	148
LCA100 Base Unit	298	135	238	108	249	113	320	145
LCA100 Max. Unit	340	154	264	120	274	124	363	165

Base Unit — The standard unit with NO OPTIONS.  
 Max. Unit — The standard unit with ALL OPTIONS Installed. (Economizer, Power Exhaust Fans, High Input Heating and Controls)

CENTER OF GRAVITY — inches (mm)

Model Number	EE		FF	
	inch	mm	inch	mm
LCA088 Base Unit	43-1/2	1105	21-1/2	546
LCA088 Max. Unit	42-1/2	1080	22	559
LCA100 Base Unit	43	1092	21	533
LCA100 Max. Unit	42	1067	21-1/2	546

Base Unit — The standard unit with NO OPTIONS.  
 Max. Unit — The standard unit with ALL OPTIONS Installed. (Economizer, Power Exhaust Fans, High Input Heating and Controls)

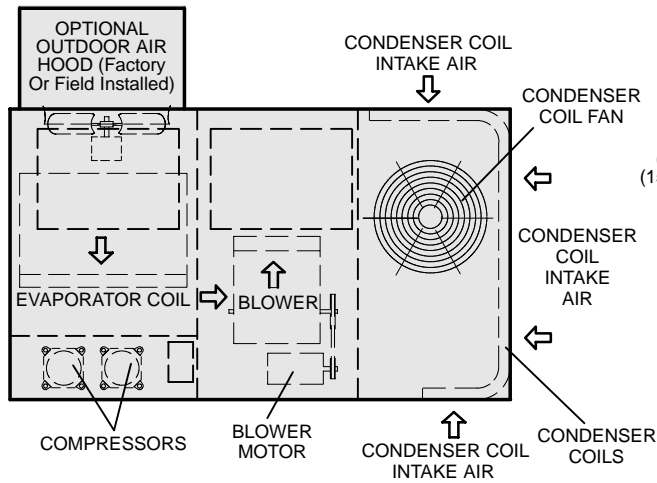

TOP VIEW

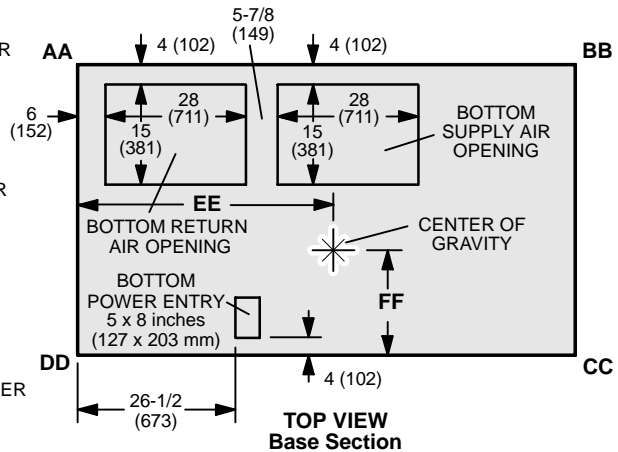

TOP VIEW  
Base Section

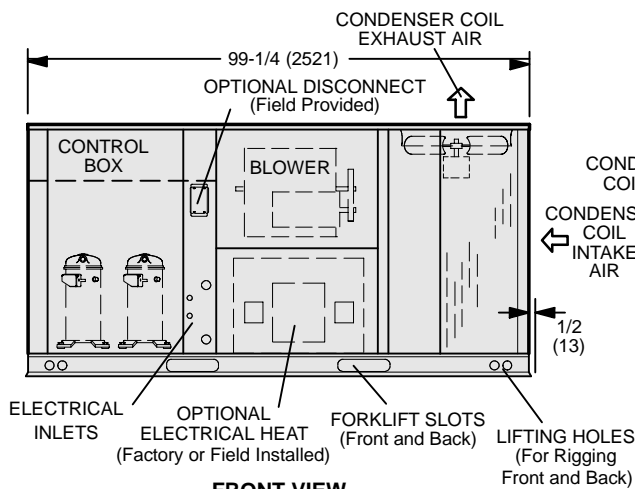

FRONT VIEW

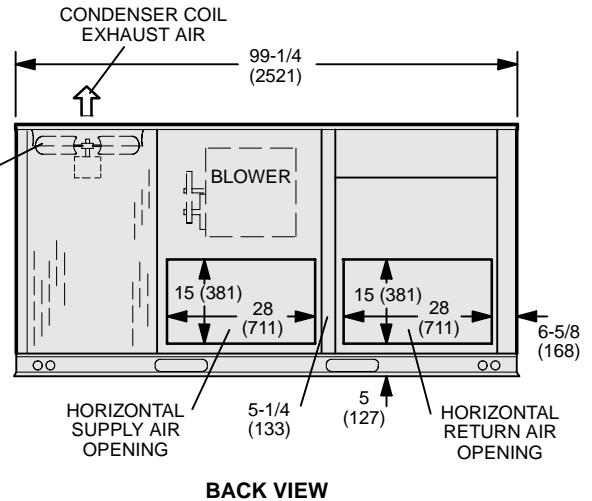

BACK VIEW

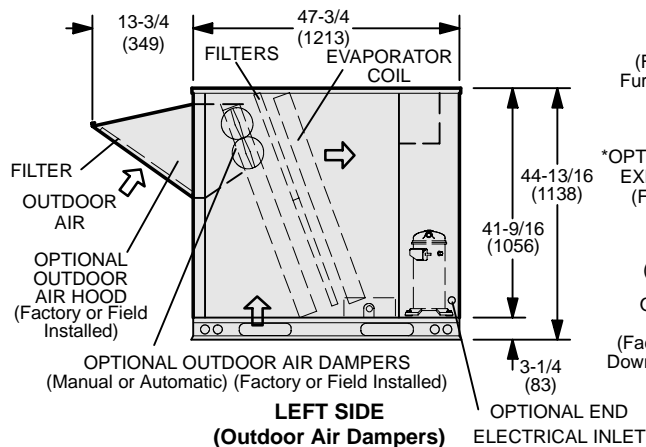

LEFT SIDE  
(Outdoor Air Dampers)

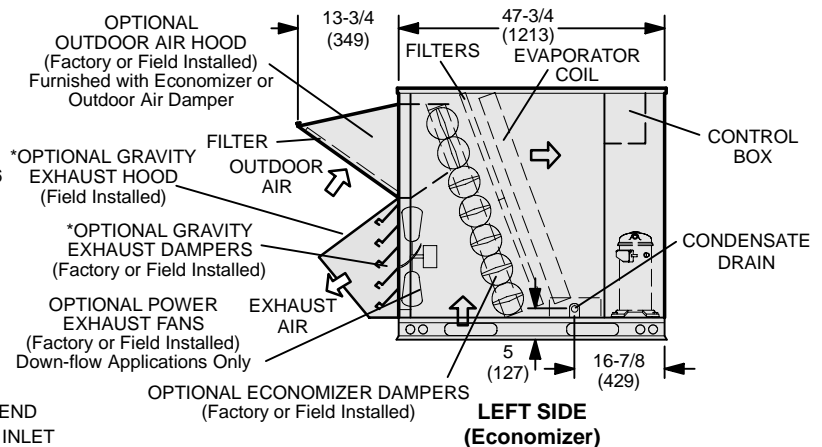

LEFT SIDE  
(Economizer)

\*NOTE - Field Installed in Return Air Duct for Horizontal Applications.

**LGA DIMENSIONS - INCHES (MM)**

**LGA088 & 100 UNITS SHOWN WITH  
OPTIONAL ECONOMIZER DAMPERS, POWER EXHAUST FANS, CONVENIENCE OUTLET, UNIT DISCONNECT  
CORNER WEIGHTS — lbs. (kg)**

Model Number	AA		BB		CC		DD	
	lbs.	kg	lbs.	kg	lbs.	kg	lbs.	kg
LGA088 Base Unit	303	137	245	111	255	116	322	146
LGA088 Max. Unit	356	161	279	127	288	131	375	170
LGA100 Base Unit	314	142	251	114	263	119	337	153
LGA100 Max. Unit	367	166	285	129	295	134	392	178

Base Unit — The standard unit with NO OPTIONS.  
Max. Unit — The standard unit with ALL OPTIONS Installed. (Economizer, Power Exhaust Fans, High Input Heating and Controls)

**CENTER OF GRAVITY — inches (mm)**

Model Number	EE		FF	
	inch	mm	inch	mm
LGA088 Base Unit	43-1/2	1105	21-1/2	546
LGA088 Max. Unit	42-1/2	1080	22	559
LGA100 Base Unit	43	1092	21	533
LGA100 Max. Unit	42	1067	21-1/2	546

Base Unit — The standard unit with NO OPTIONS.  
Max. Unit — The standard unit with ALL OPTIONS Installed. (Economizer, Power Exhaust Fans, High Input Heating and Controls)

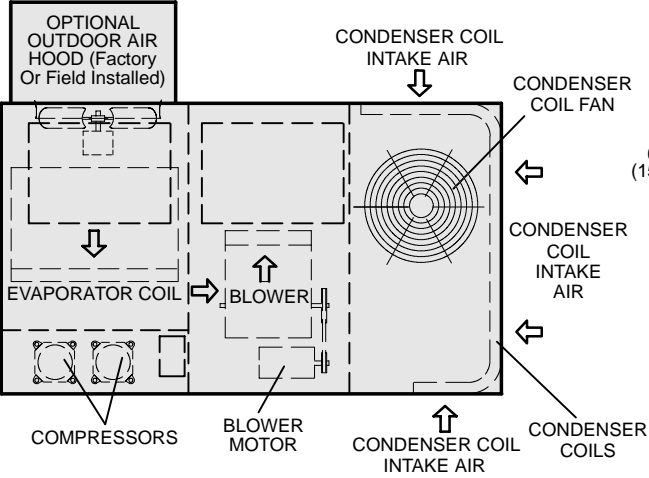

**TOP VIEW**

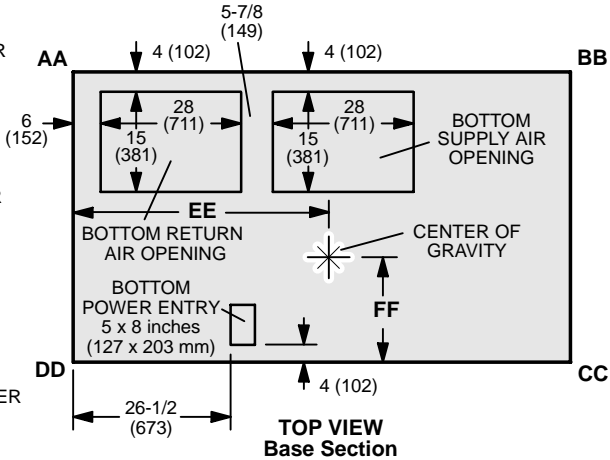

**TOP VIEW  
Base Section**

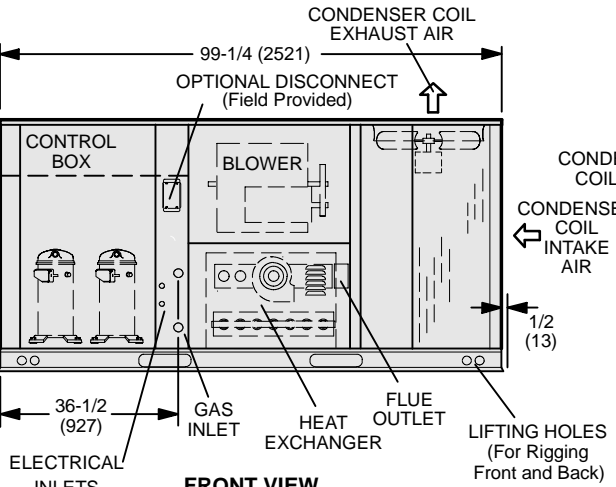

**FRONT VIEW**

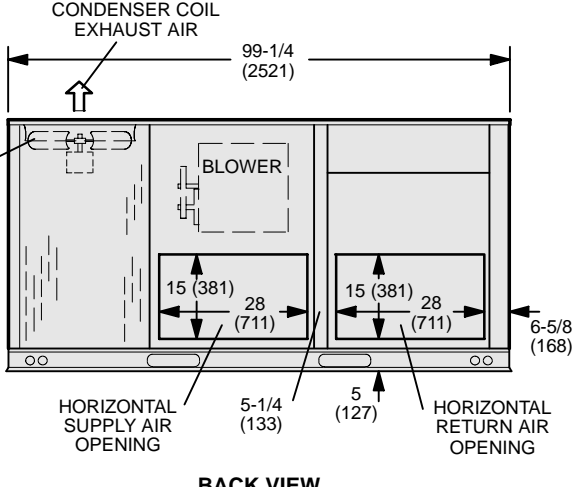

**BACK VIEW**

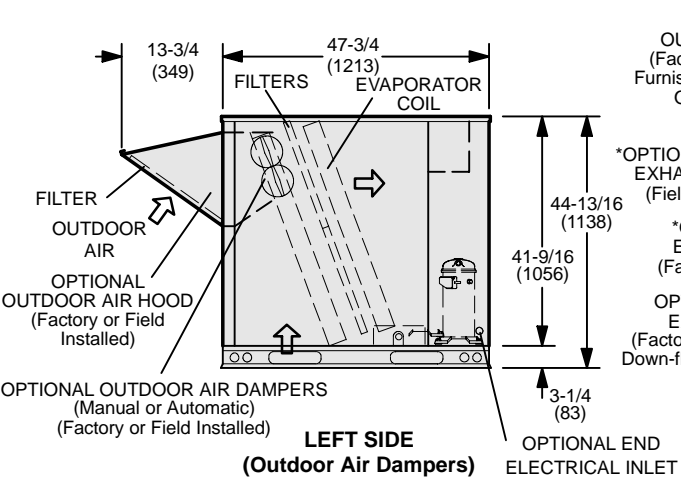

**LEFT SIDE  
(Outdoor Air Dampers)**

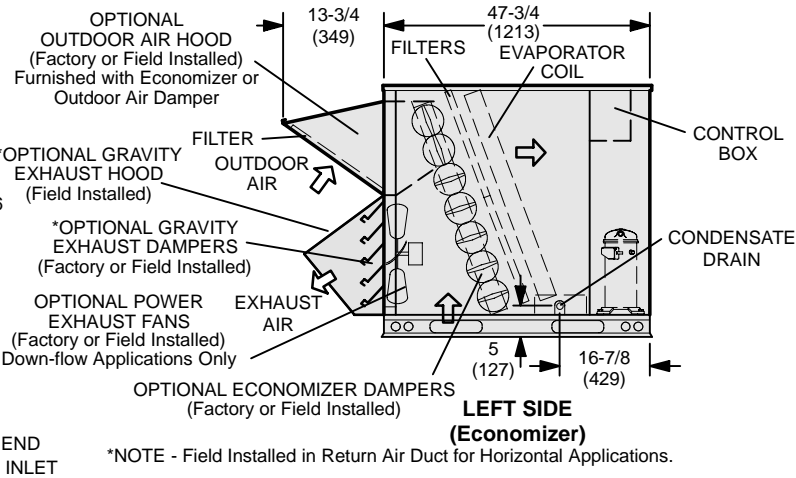

**LEFT SIDE  
(Economizer)**

\*NOTE - Field Installed in Return Air Duct for Horizontal Applications.

# LHA DIMENSIONS - INCHES (MM)

LHA088 UNIT SHOWN WITH  
 OPTIONAL ECONOMIZER DAMPERS, POWER EXHAUST FANS, CONVENIENCE OUTLET, UNIT DISCONNECT  
 CORNER WEIGHTS — lbs. (kg)

Model Number	AA		BB		CC		DD	
	lbs.	kg	lbs.	kg	lbs.	kg	lbs.	kg
LHA088 Base Unit	264	120	214	97	222	101	280	127
LHA088 Max. Unit	306	139	240	109	248	112	322	146

Base Unit — The standard unit with NO OPTIONS.  
 Max. Unit — The standard unit with ALL OPTIONS Installed. (Economizer, Power Exhaust Fans, High Input Heating and Controls)

CENTER OF GRAVITY — inches (mm)

Model Number	EE		FF	
	inch	mm	inch	mm
LHA088 Base Unit	43-1/2	1105	21-1/2	546
LHA088 Max. Unit	42-1/2	1080	22	559

Base Unit — The standard unit with NO OPTIONS.  
 Max. Unit — The standard unit with ALL OPTIONS Installed. (Economizer, Power Exhaust Fans, High Input Heating and Controls)

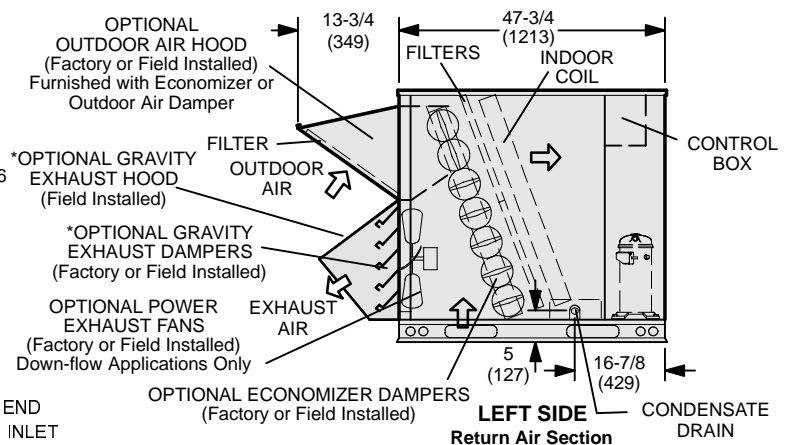
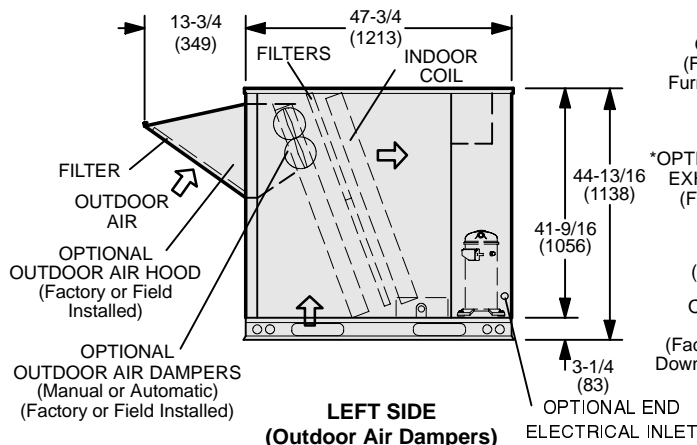
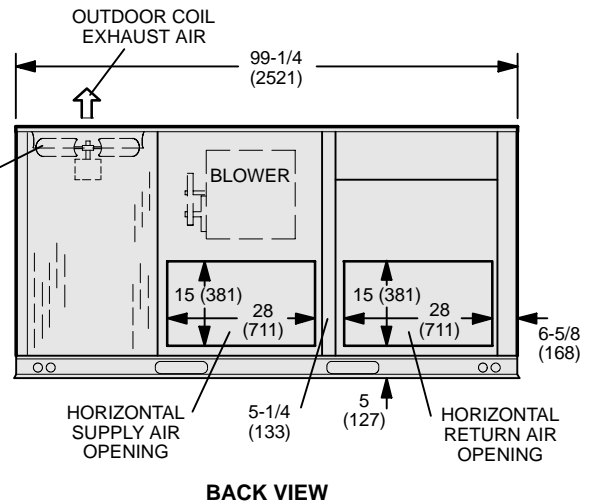
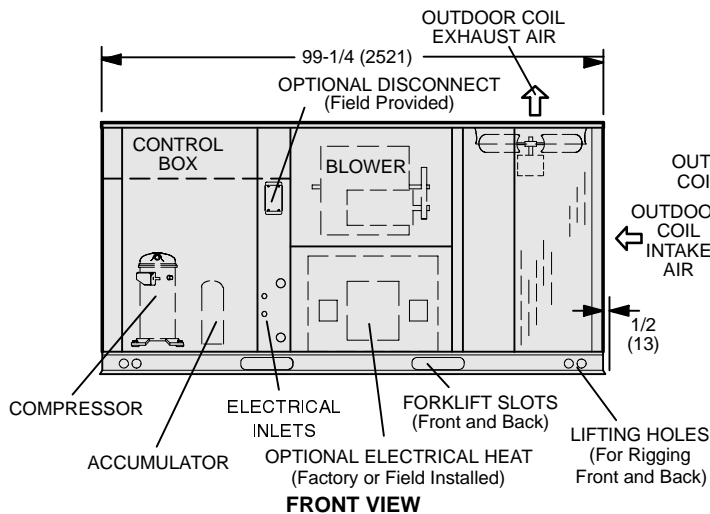
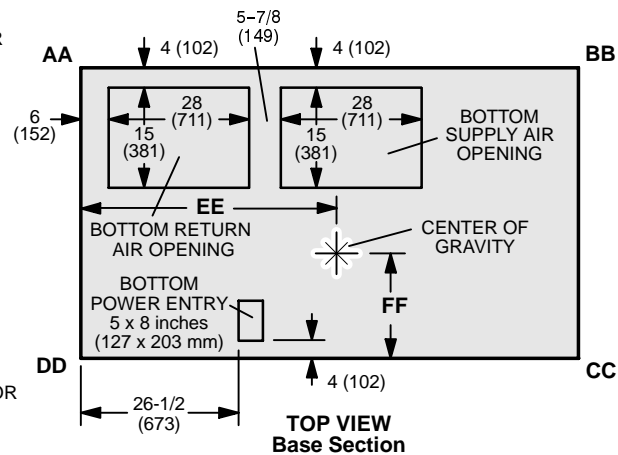
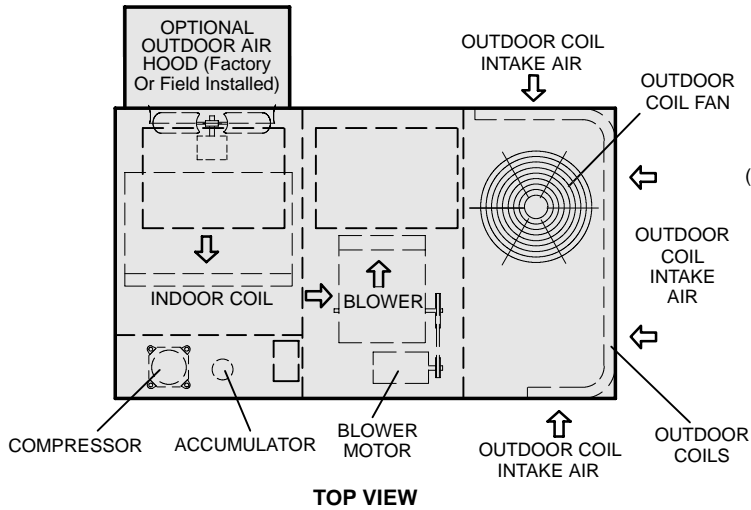

\*NOTE - Field Installed in Return Air Duct for Horizontal Applications.

**ACCESSORY DIMENSIONS - INCHES (MM)**

**LARMF08/10 — ROOF MOUNTING FRAME (Double Duct Opening)**

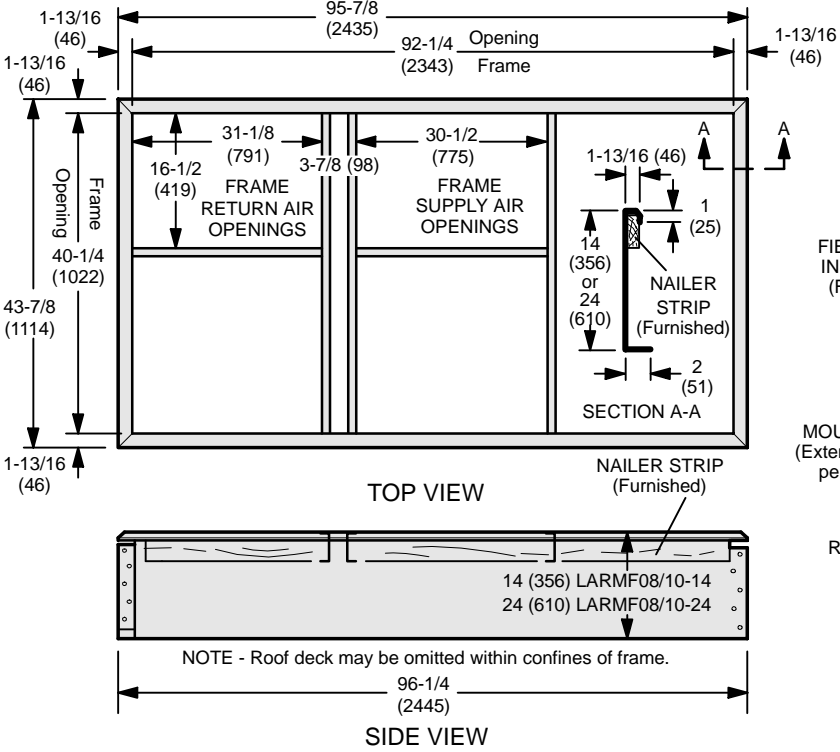

**TYPICAL FLASHING DETAIL**

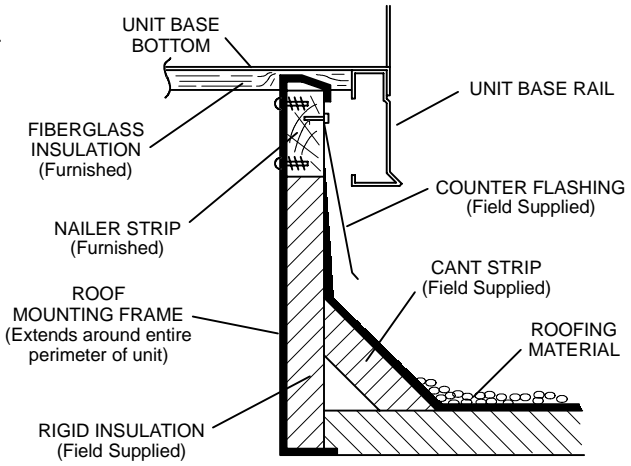

**LARMF08/10 ROOF MOUNTING FRAME WITH LASRT08/10 Transition**

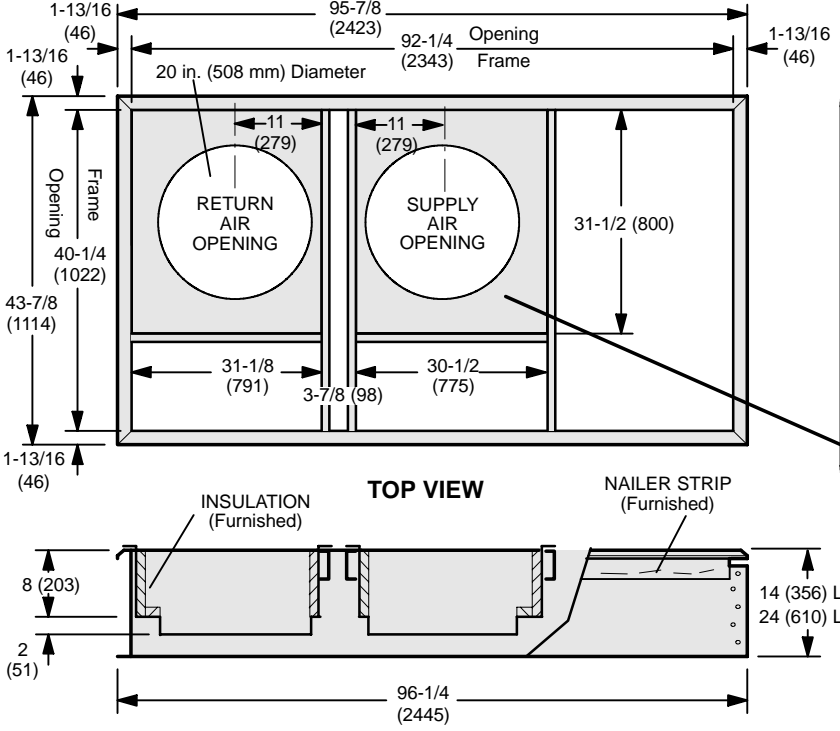

**LASRT08/10 TRANSITION DETAIL**

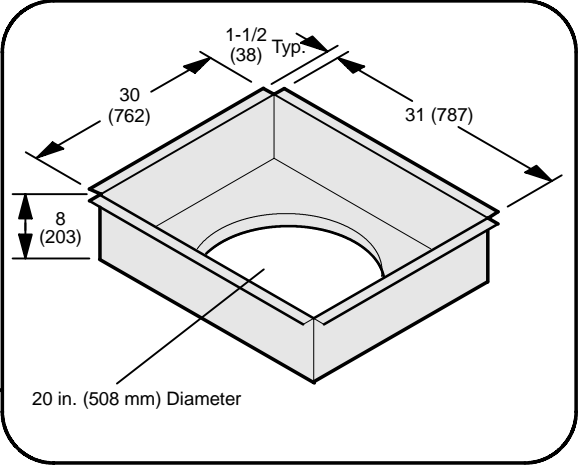

**ROOF MOUNTING FRAME SPECIFICATIONS**

Roof mounting frame is rigid enough to be spanned over its entire length or cantilevered if supported on both sides of center of gravity

Roof Mounting Frame	LARMF08/10-14	LARMF08/10-24
*Moment of Inertia (I) (in. <sup>4</sup> ) (cm <sup>4</sup> )	39 (1634)	160 (6639)
*Section modulus $\frac{I}{C}$ (in. <sup>3</sup> ) (cm <sup>3</sup> )	5.5 (90)	13.1 (512)
Frame weight (lb/ft) (kg/m) of length	5.5 (8.2)	8.5 (12.7)
Design strength (psi) (kPa)	20,000 (137,900)	

\*Includes both sides of frame.

**ACCESSORY DIMENSIONS - INCHES (MM)**

**COMBINATION CEILING SUPPLY AND RETURN DIFFUSERS**

**RTD11-95 STEP-DOWN CEILING DIFFUSER**

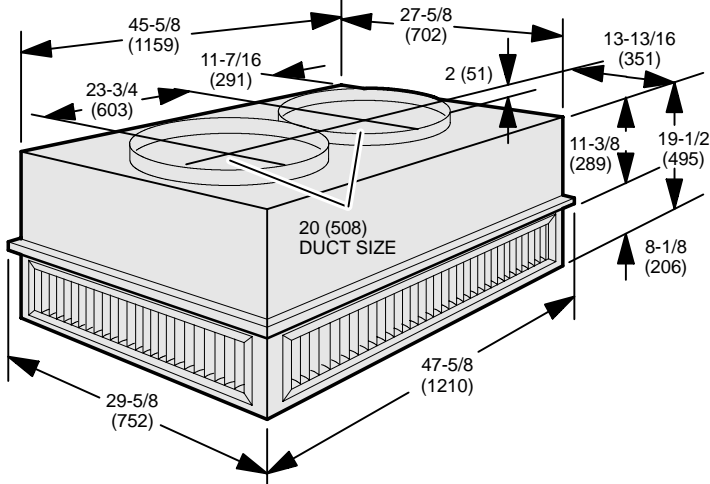

**FD11-95 FLUSH CEILING DIFFUSER**

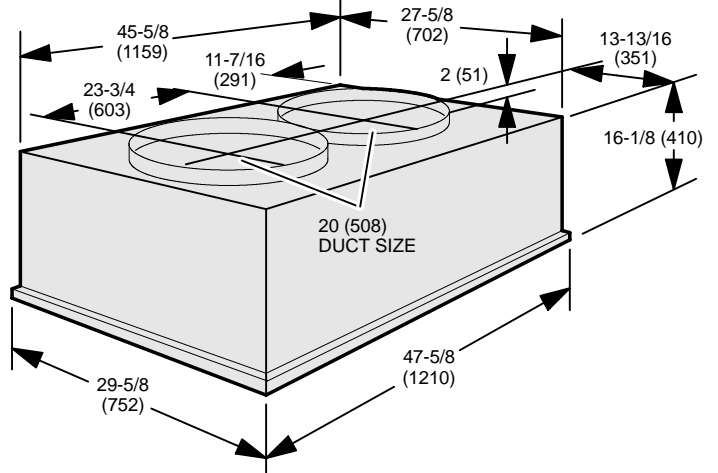

**LAGEDH08/10 HORIZONTAL GRAVITY EXHAUST DAMPERS  
(Field Installed in Return Air Duct)**

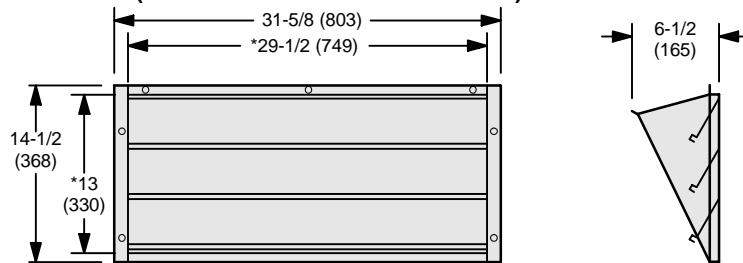

**FRONT VIEW**

**SIDE VIEW**

\*NOTE - Opening size required in return air duct.

**INSTALLATION CLEARANCES - INCHES (MM)**

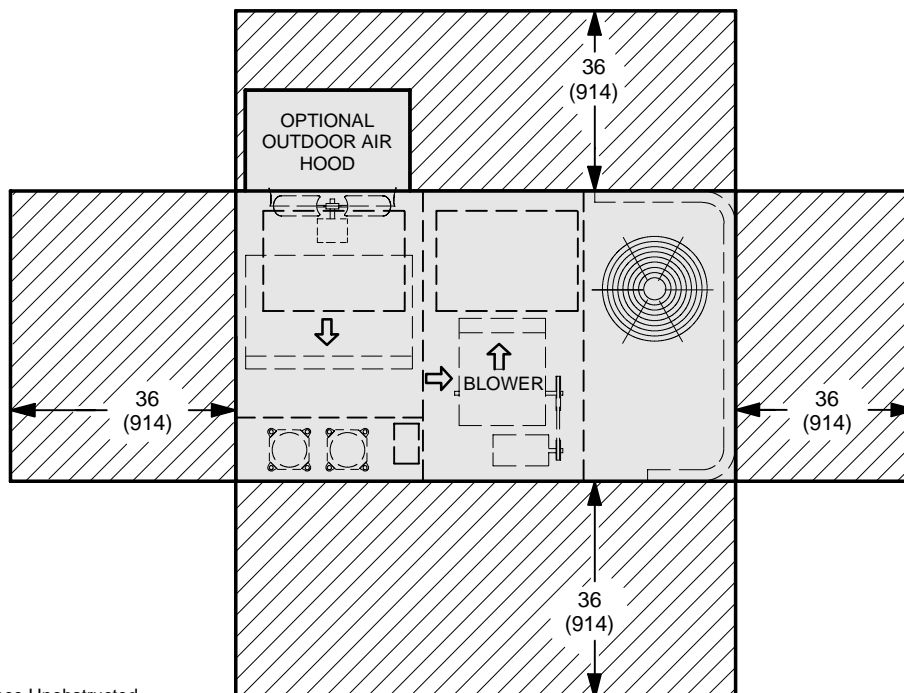

NOTE - Top Clearance Unobstructed.

NOTE - Entire perimeter of unit base require support when elevated above mounting surface. Minimum Clearance To Combustible Materials