

Input B1-B2-B3-B4

Input	1	2	3
0/1V	OFF	OFF	OFF
NTC	DN	OFF	OFF
0/20mA	OFF	DN	OFF
0/5V	OFF	OFF	DN

Input B5-B6

Input	digital input	NTC
DN	OFF	OFF

Input B1-B2-B3-B4

Input	1	2	3
0/1V	OFF	OFF	OFF
NTC	DN	OFF	OFF
0/20mA	OFF	DN	OFF
0/5V	OFF	OFF	DN

Input B5-B6

Input	digital input	NTC
DN	OFF	OFF

AVEC TCB SANS CARTE EXTENSION
WITHOUT EXTENSIONBOARD BES0

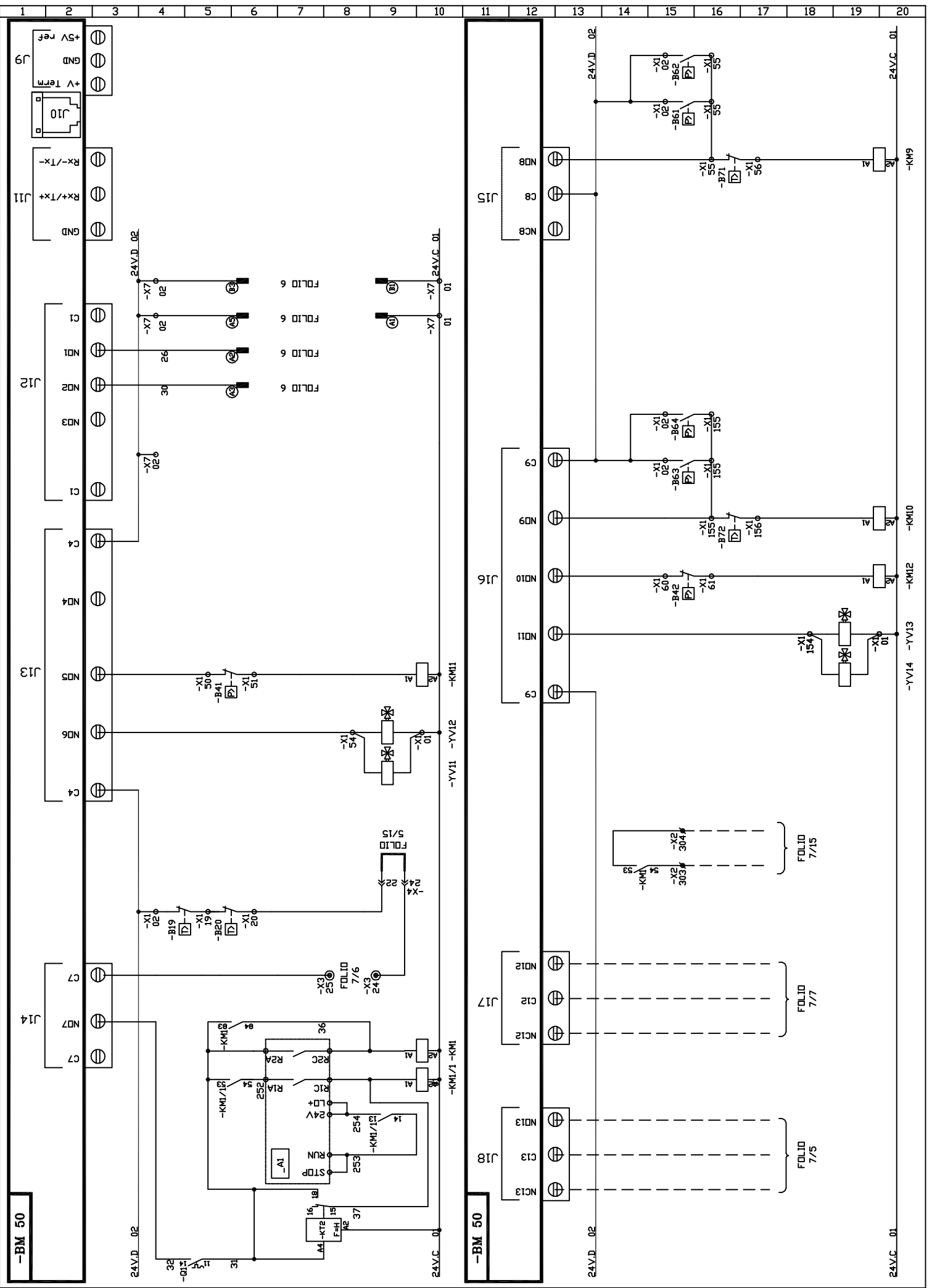

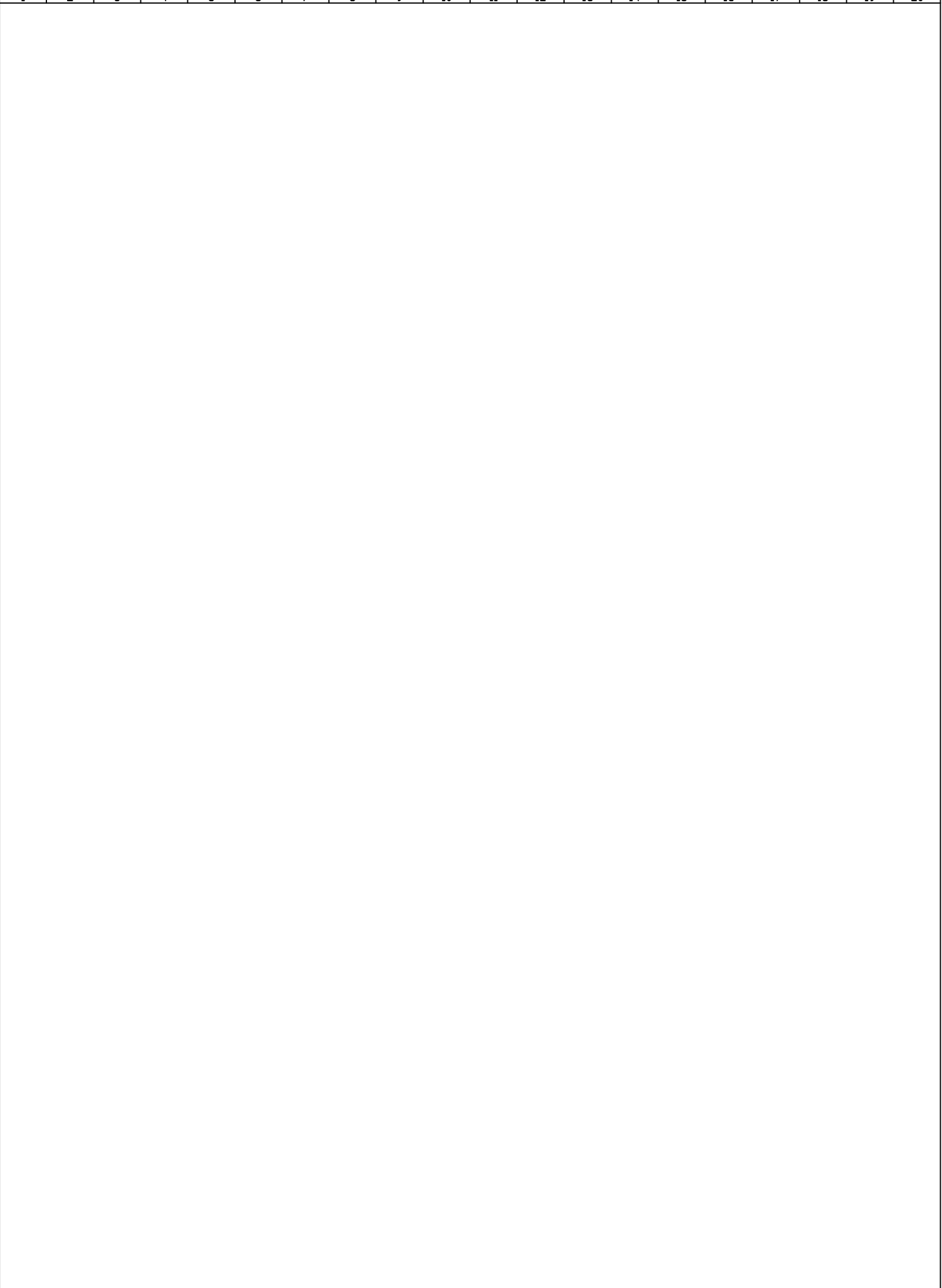

				(1) FXK 170 Kit chauffage GAS	Dessine: T/Y		<table border="1"> <tr> <td>236621</td> <td>6</td> </tr> <tr> <td></td> <td>11</td> </tr> </table>	236621	6		11
236621	6										
	11										
Indice	DATE	NOM	MODIFICATIONS		Date: 26.05.04	USINE DE LONGVIC					

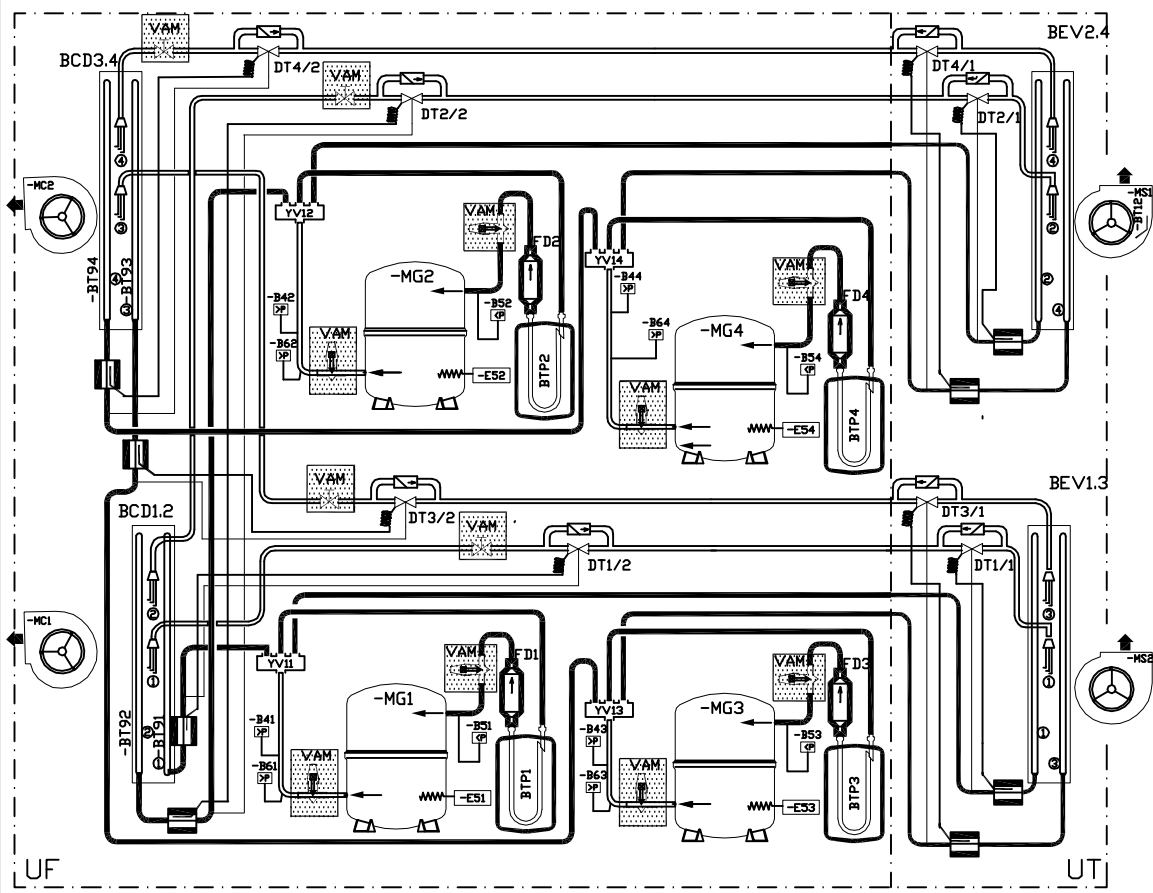

DIAMETRE TUYAUTERIES

REFOULEMENT	7/8"
ASPIRATION	1"1/8"
LIGNE LIQUIDE	5/8"

— TUYAUTERIE CALDRIFUGEE
 — TUYAUTERIE NON CALDRIFUGEE

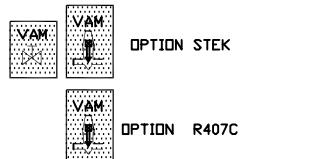

RTR	22	25	27
BEV	2*9V	2*18V	2*18V
BCD	2*9V	2*9V	2*9V

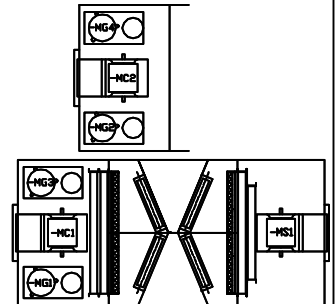

Indice	DATE	NOM	MODIFICATIONS

(1) FXK 170
 Schéma Frigorifique \ Hydraulique
 Cooling \ Hydraulic Diagram

Dessine: T/Y
 Date: 26.05.04

LENNOX
 USINE DE LONGVIC

236621 9/11

