

Indice	DATE	NOM	MODIFICATIONS		
					
<i>Renishaw</i>					
(2) FHM 150 N LENNOX UK		Dessine: CTO Date: 20.07.06	PAGE DE GARDE <table border="1" style="float: right;"> <tr> <td>249603</td> <td>0 / 11</td> </tr> </table>	249603	0 / 11
249603	0 / 11				

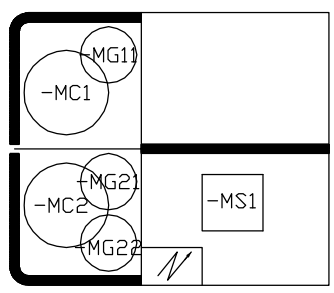

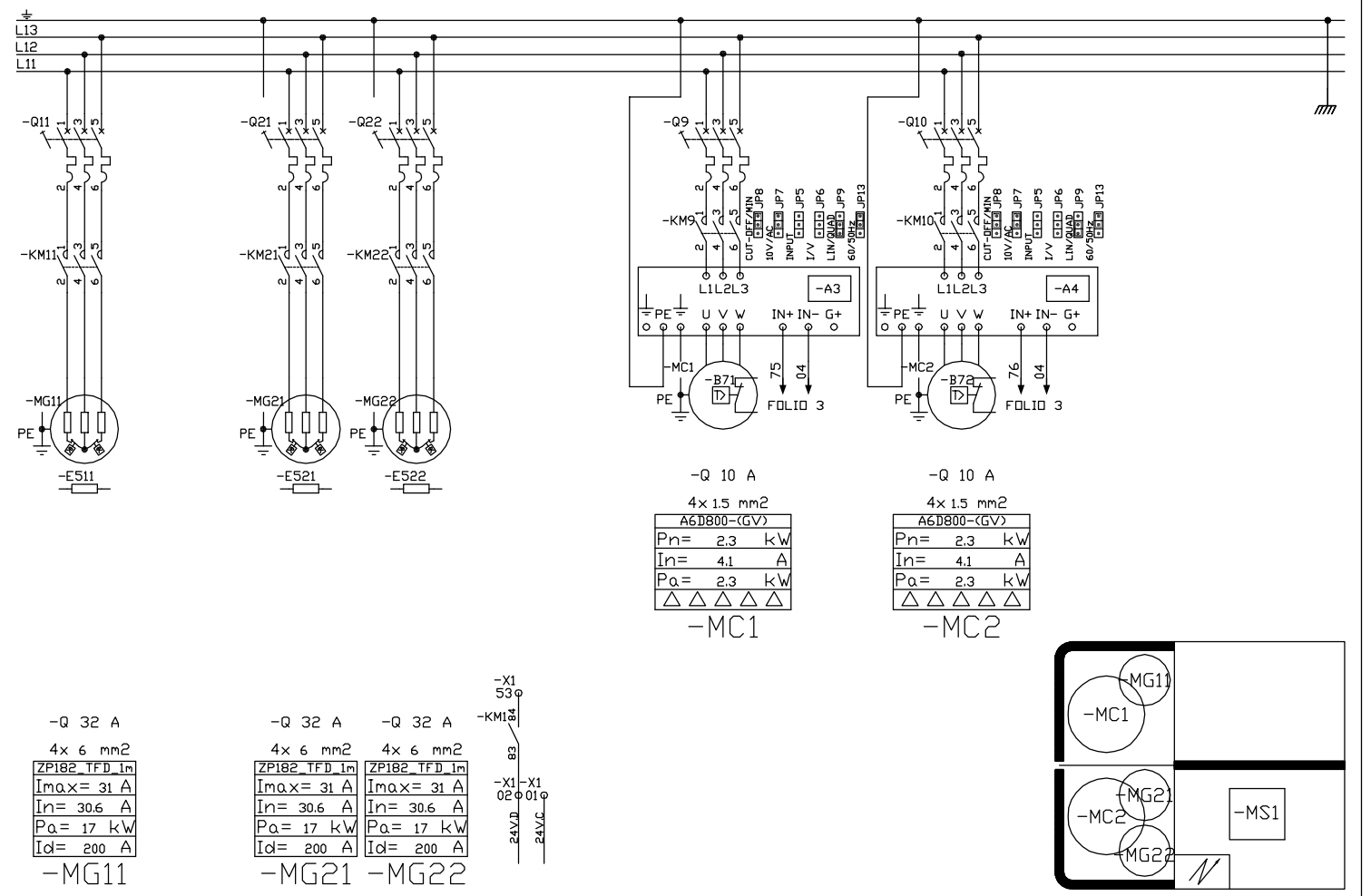
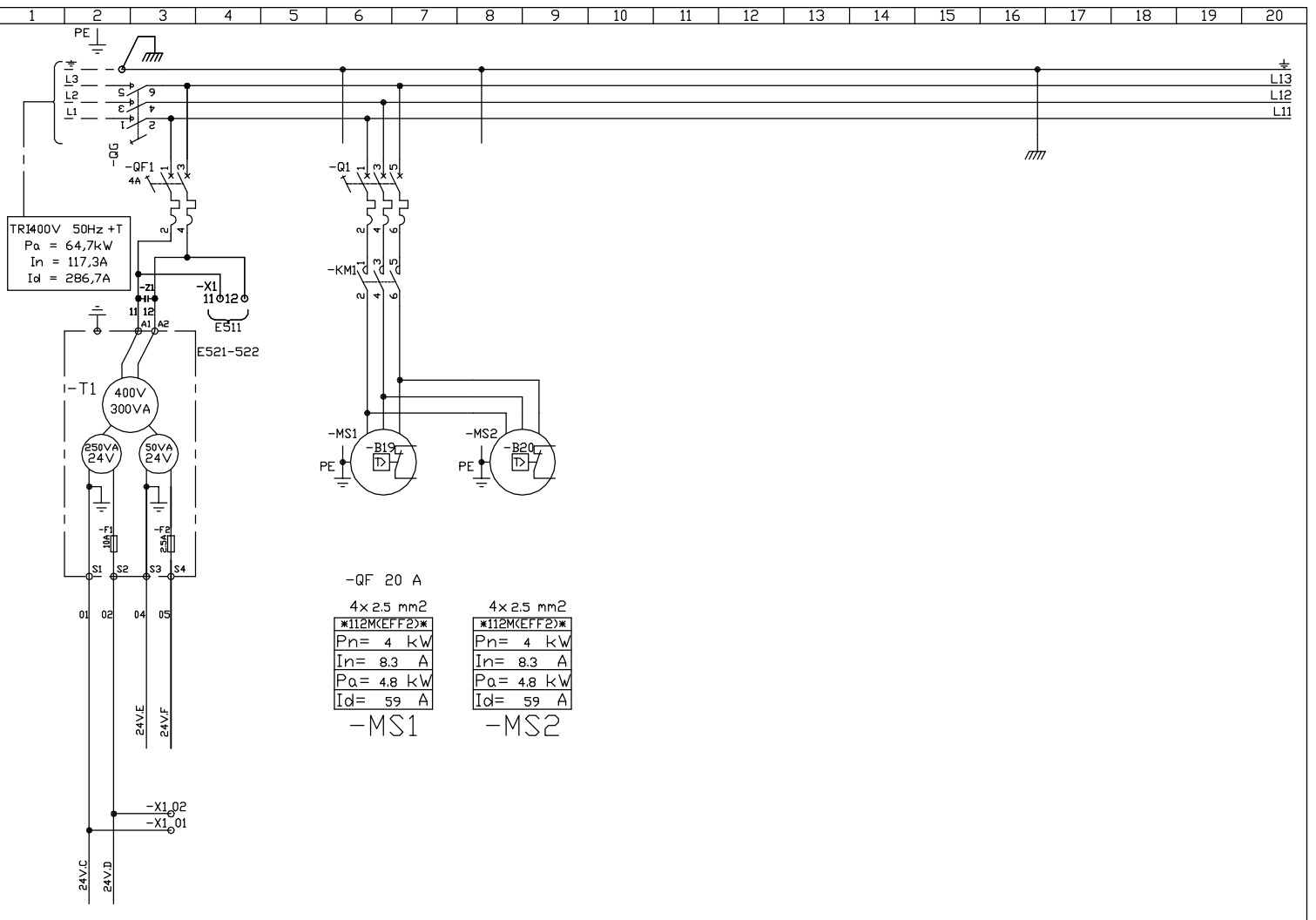
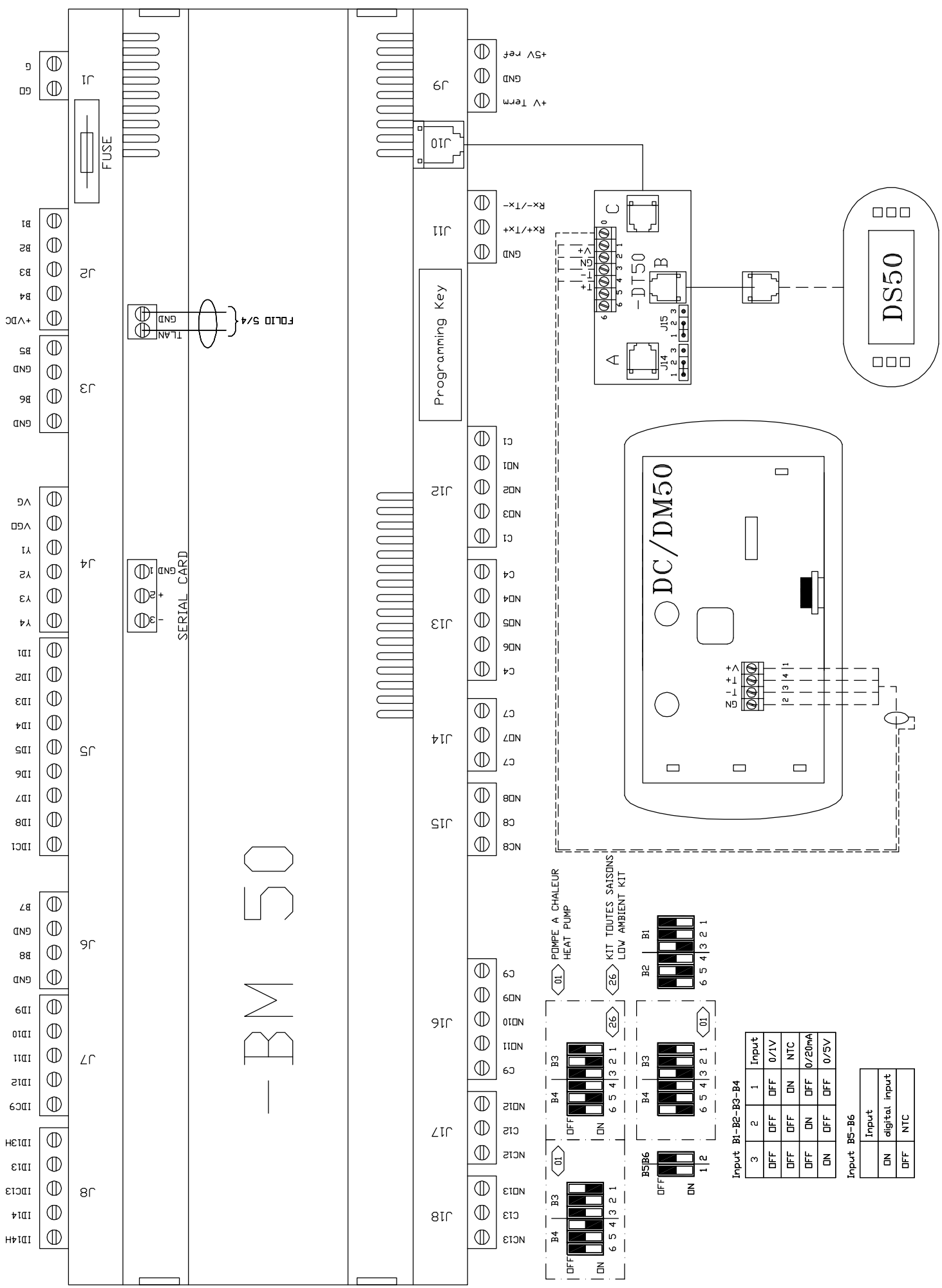

Indice	DATE	NOM	MODIFICATIONS

(2) FHM 150 N
Automate CLIMATIC 50
Climatic 50 Controller

Dessine: CTO
Date: 20.07.06



249603 2/11

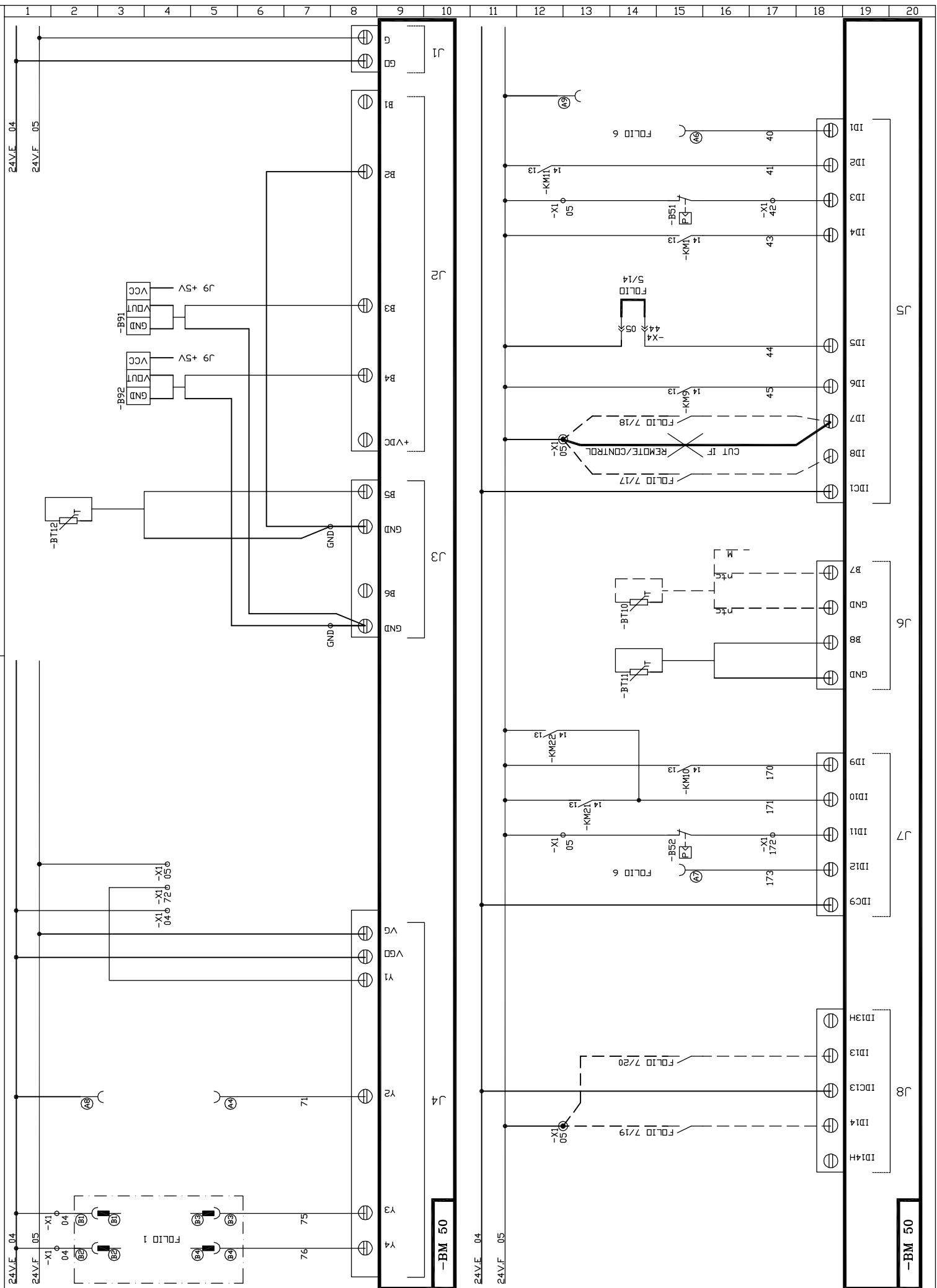

Indice	DATE	NOM	MODIFICATIONS

(2) FHM 150 N
Entrées Automate CLIMATIC 50
Climatic 50 Controller Input

Dessine: CTO
Date: 20.07.06



249603 3/11

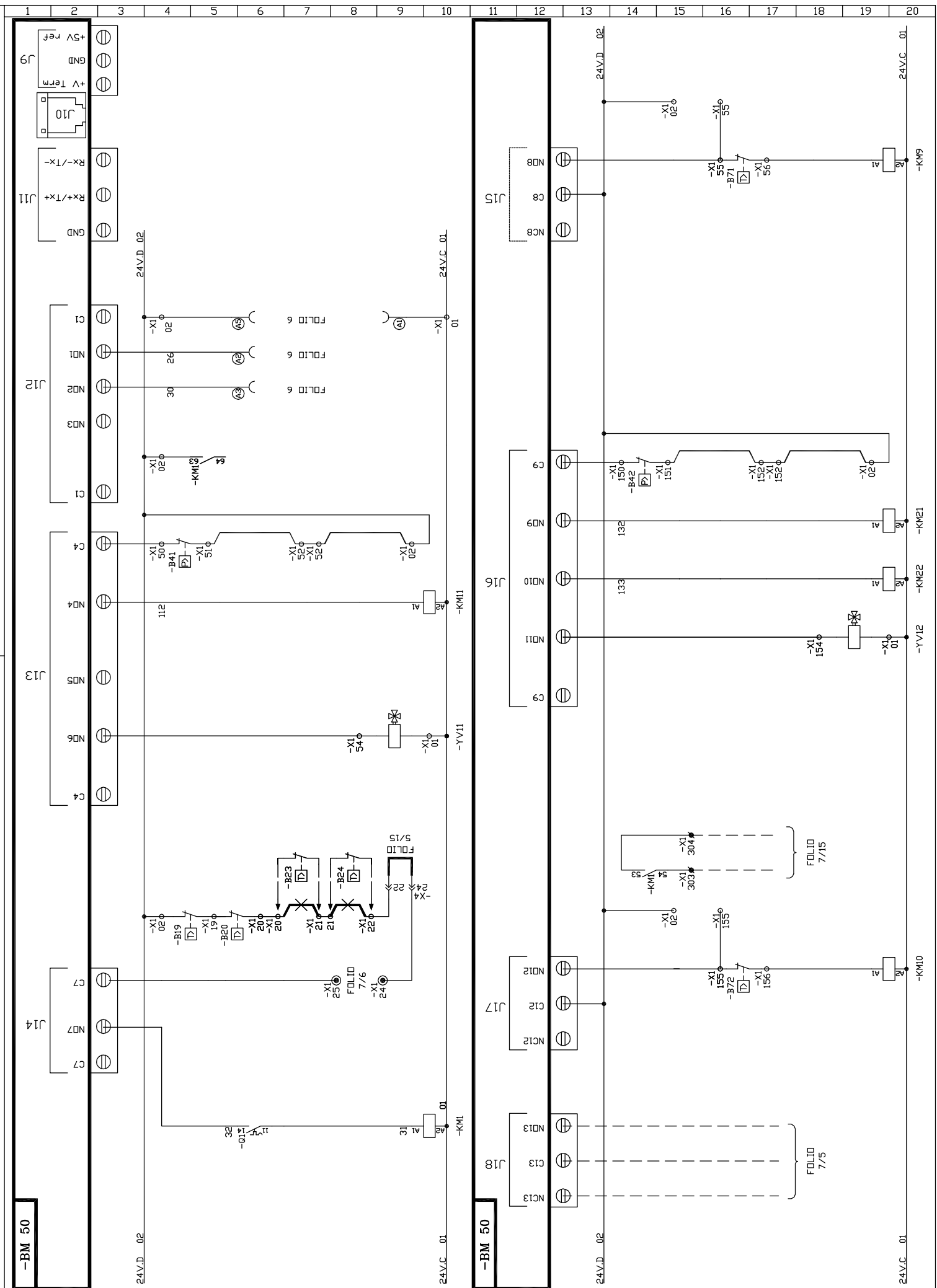

Indice	DATE	NOM	MODIFICATIONS

(2) FHM 150 N
Sorties Automate CLIMATIC 50
Climatic 50 Controller Outputs

Dessine: CTO
Date: 20.07.06



249603 4/11

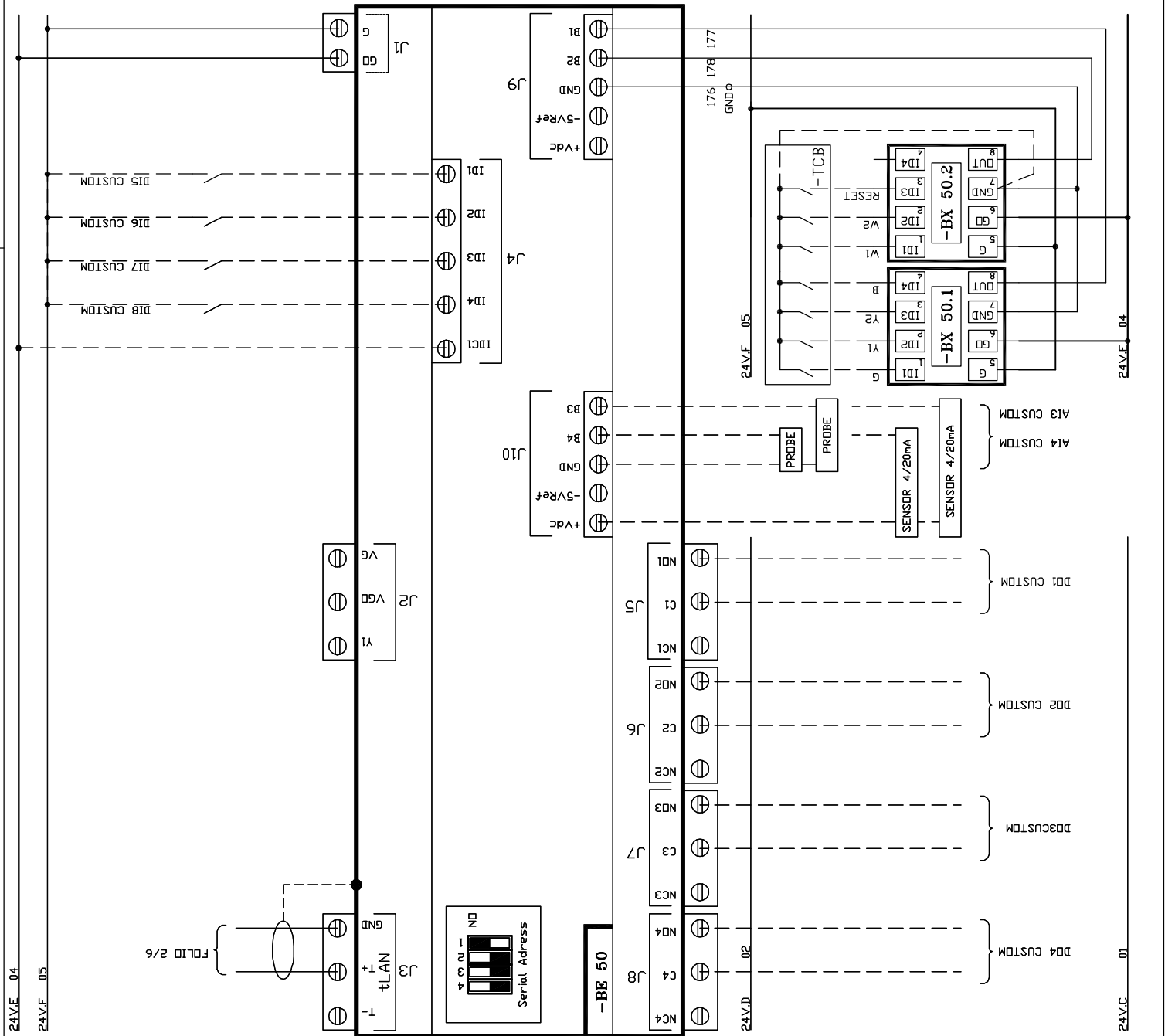
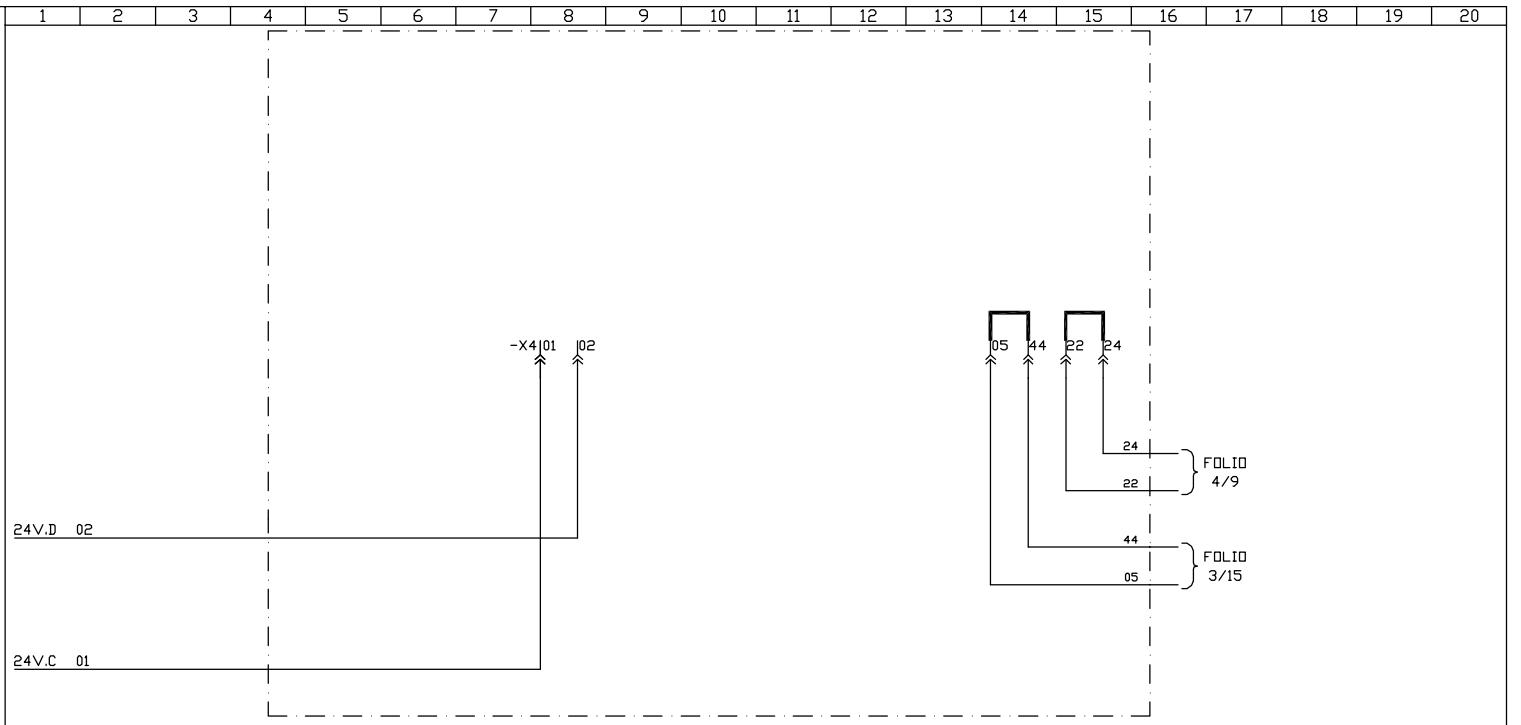

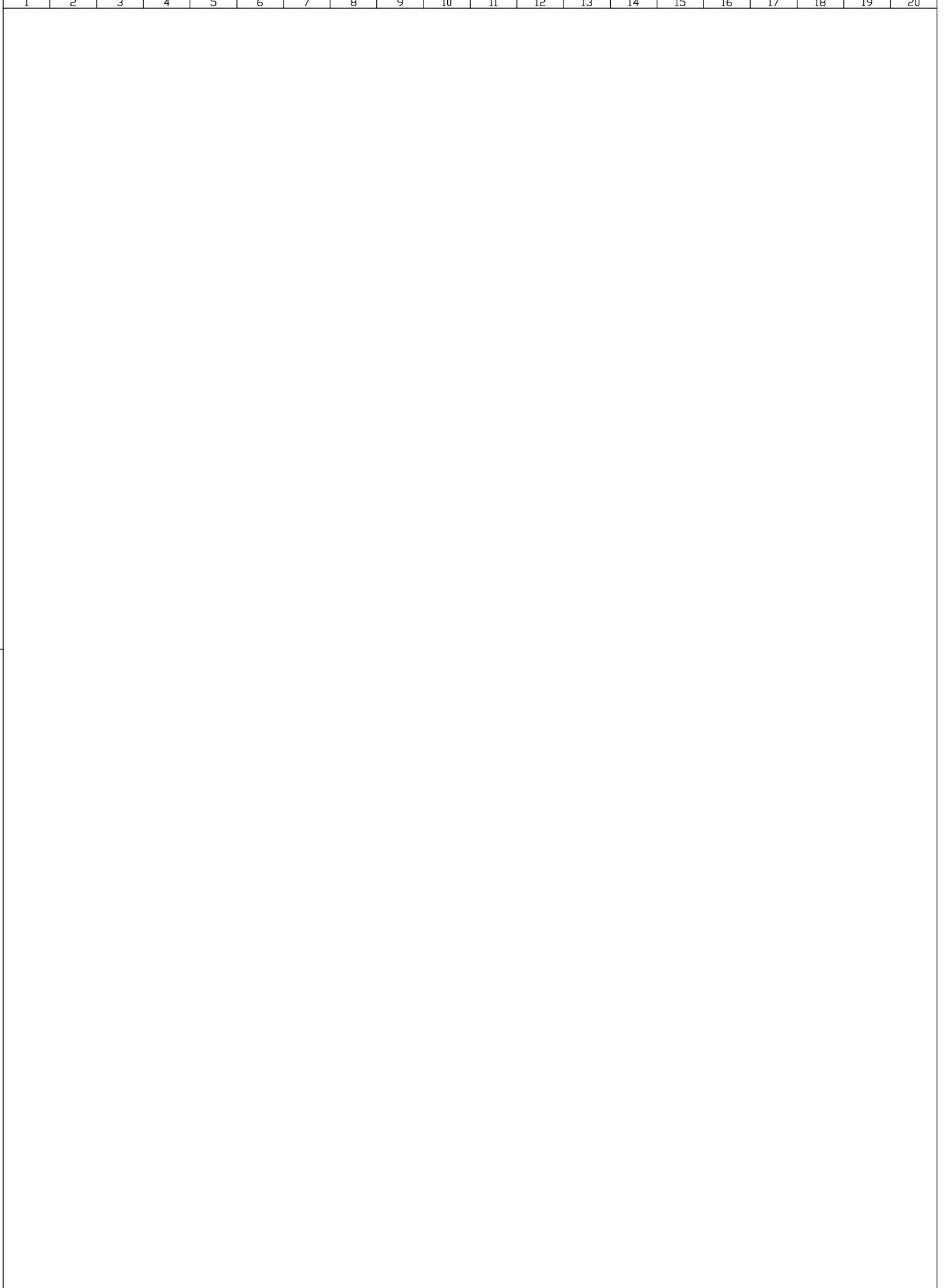

					(2) FHM 150 N Kit chauffage GAS	Dessine: CTO Date: 20.07.06	 USINE DE LONGVIC	249603 	6 /11
Indice	DATE	NOM	MODIFICATIONS						

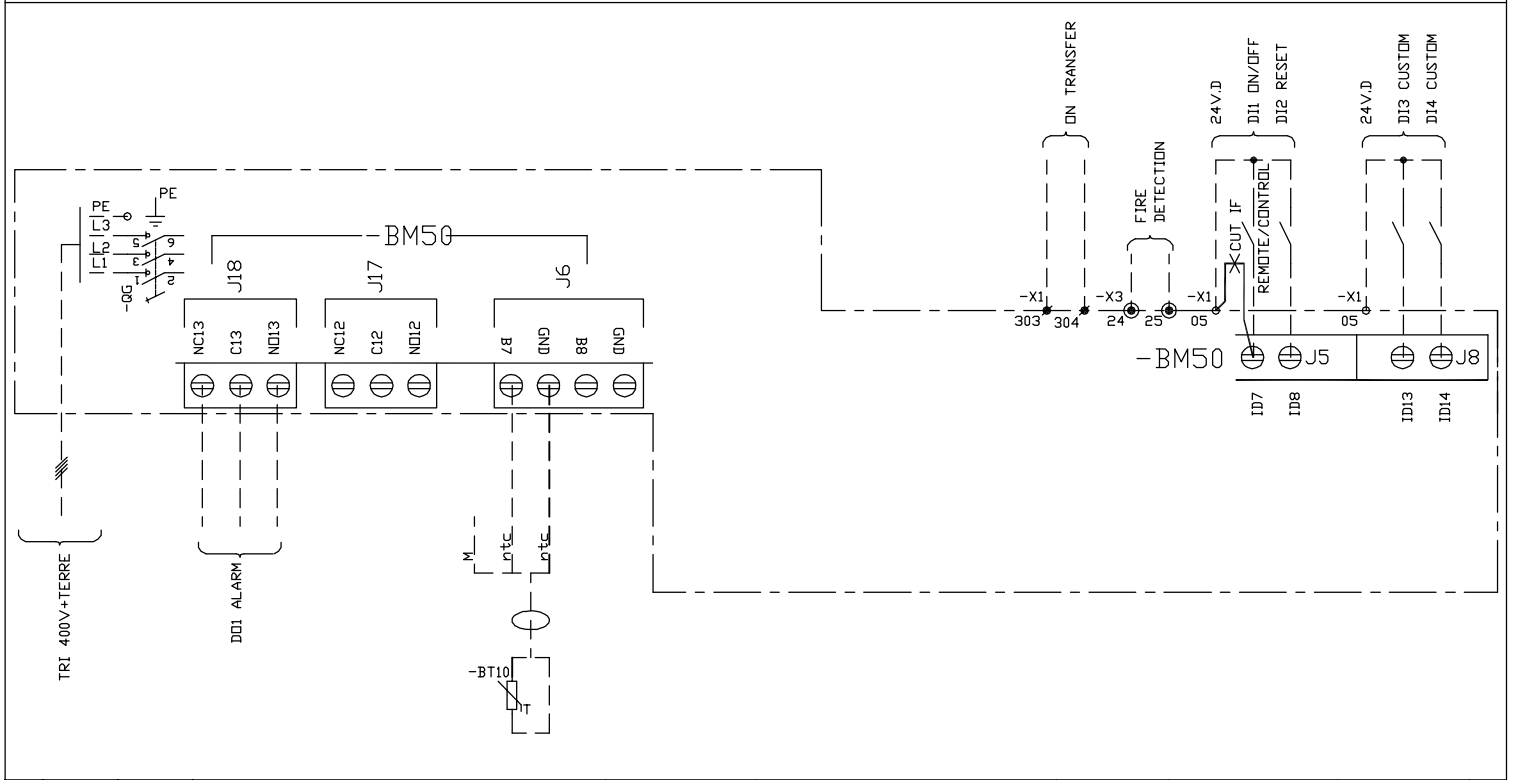
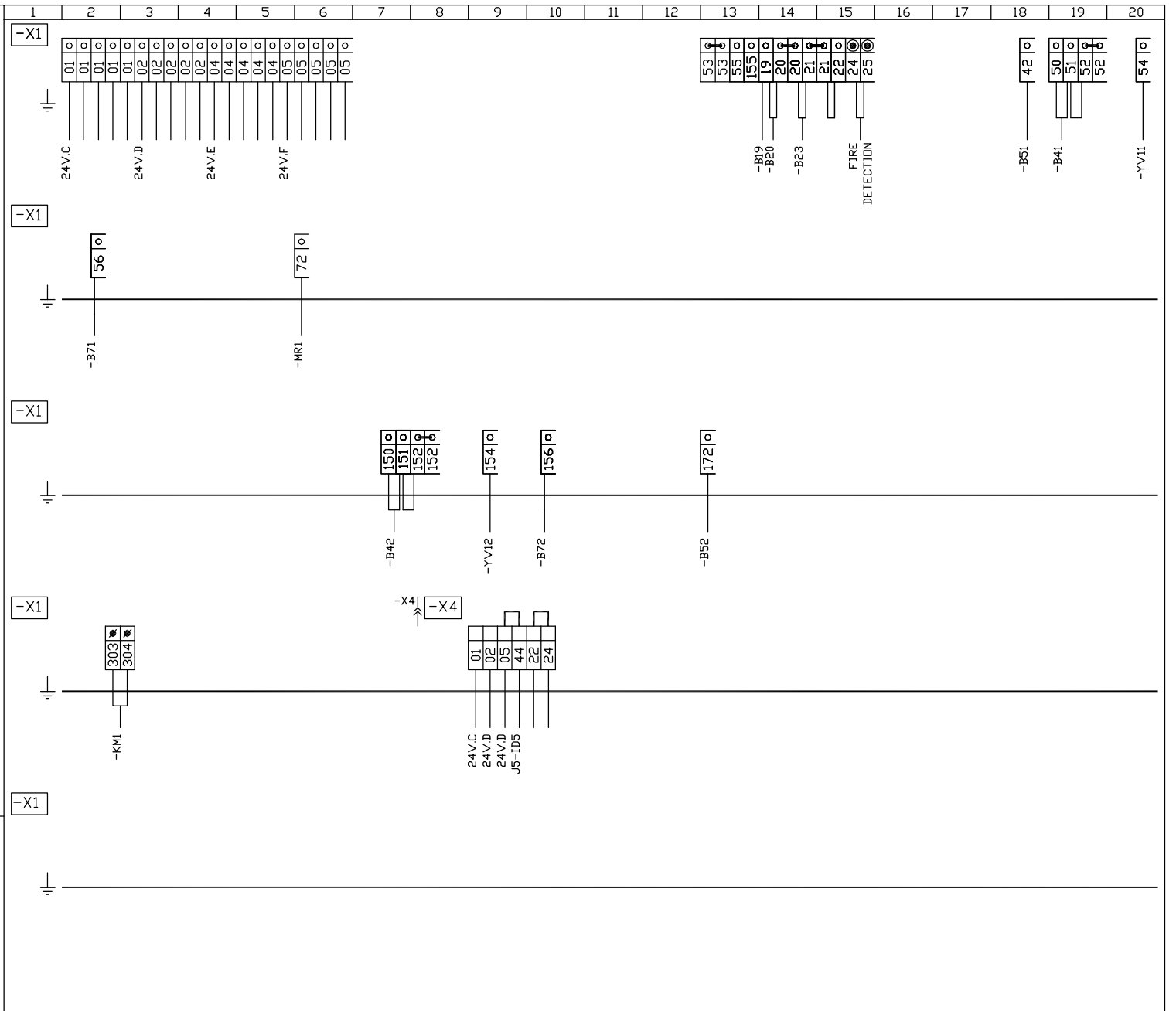

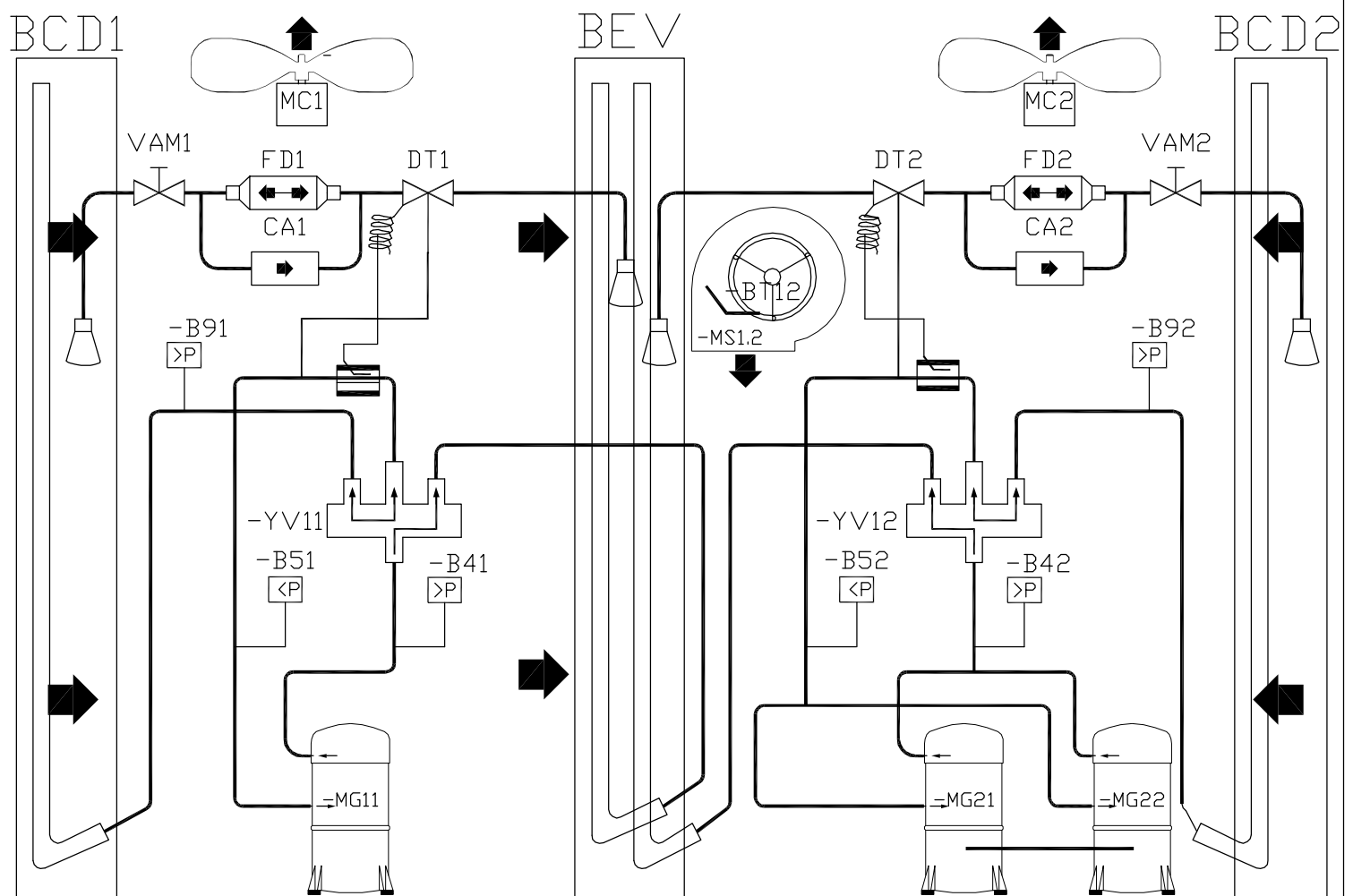

Indice	DATE	NOM	MODIFICATIONS

(2) FHM 150 N
 Schéma Frigorifique \ Hydraulique
 Cooling \ Hydraulic Diagram

Dessine: CTO
 Date: 20.07.06



249603 9/11

