

Indice	DATE	NOM	MODIFICATIONS
			
Portable Foods			
(1) FHK 190 N LENNOX UK	Dessine: T/Y	PAGE DE GARDE	249473
	Date: 18.08.06		0 / 11

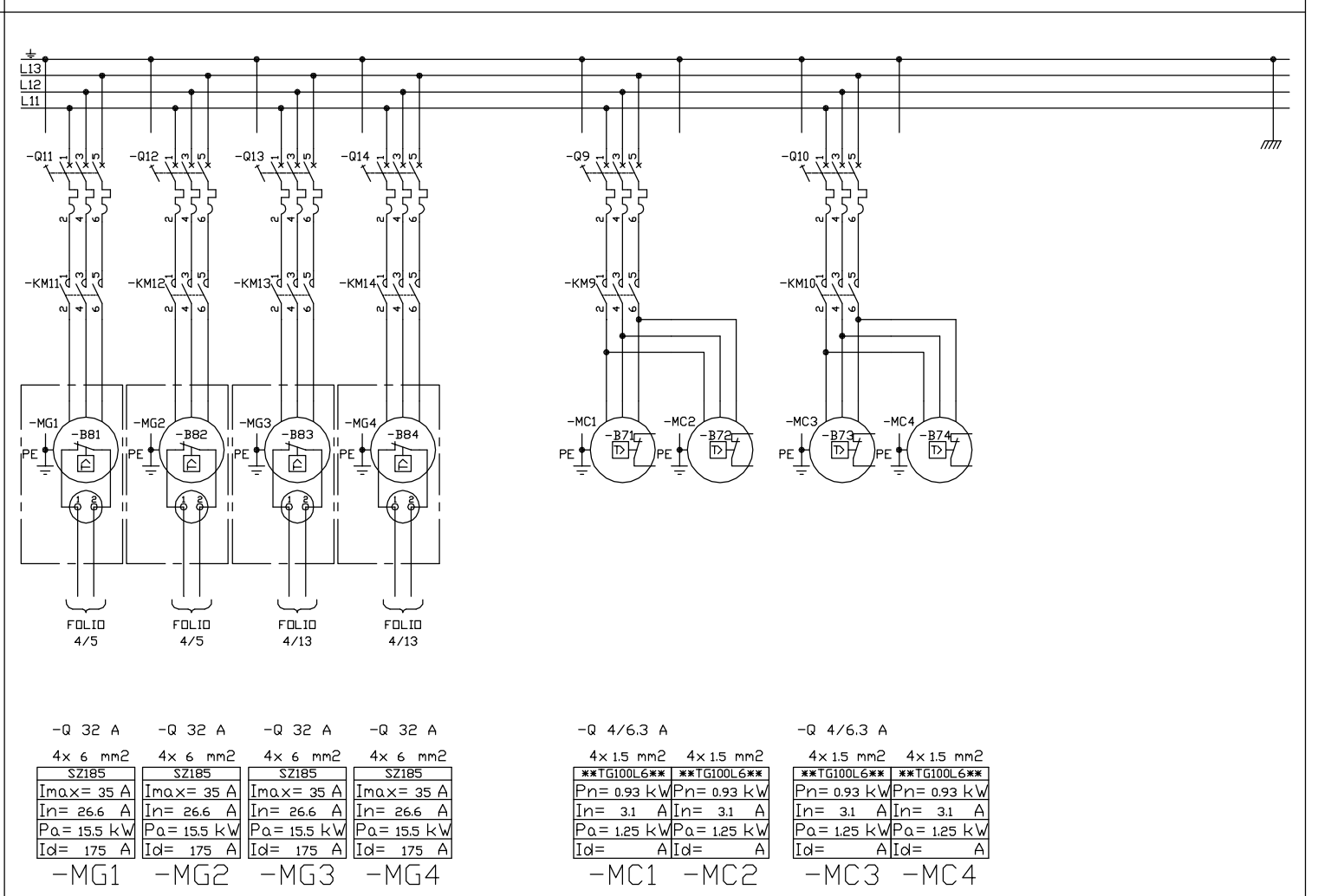

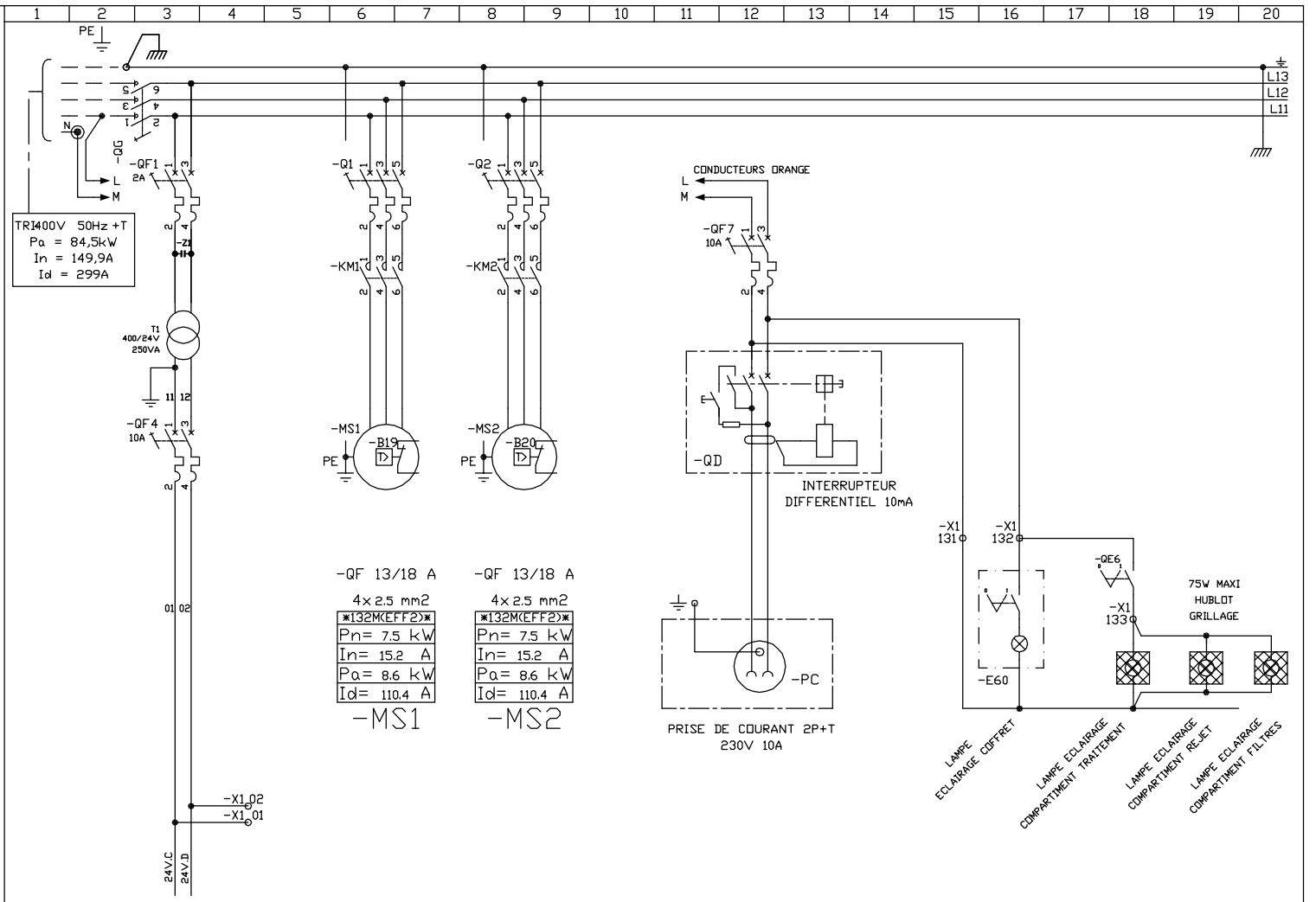
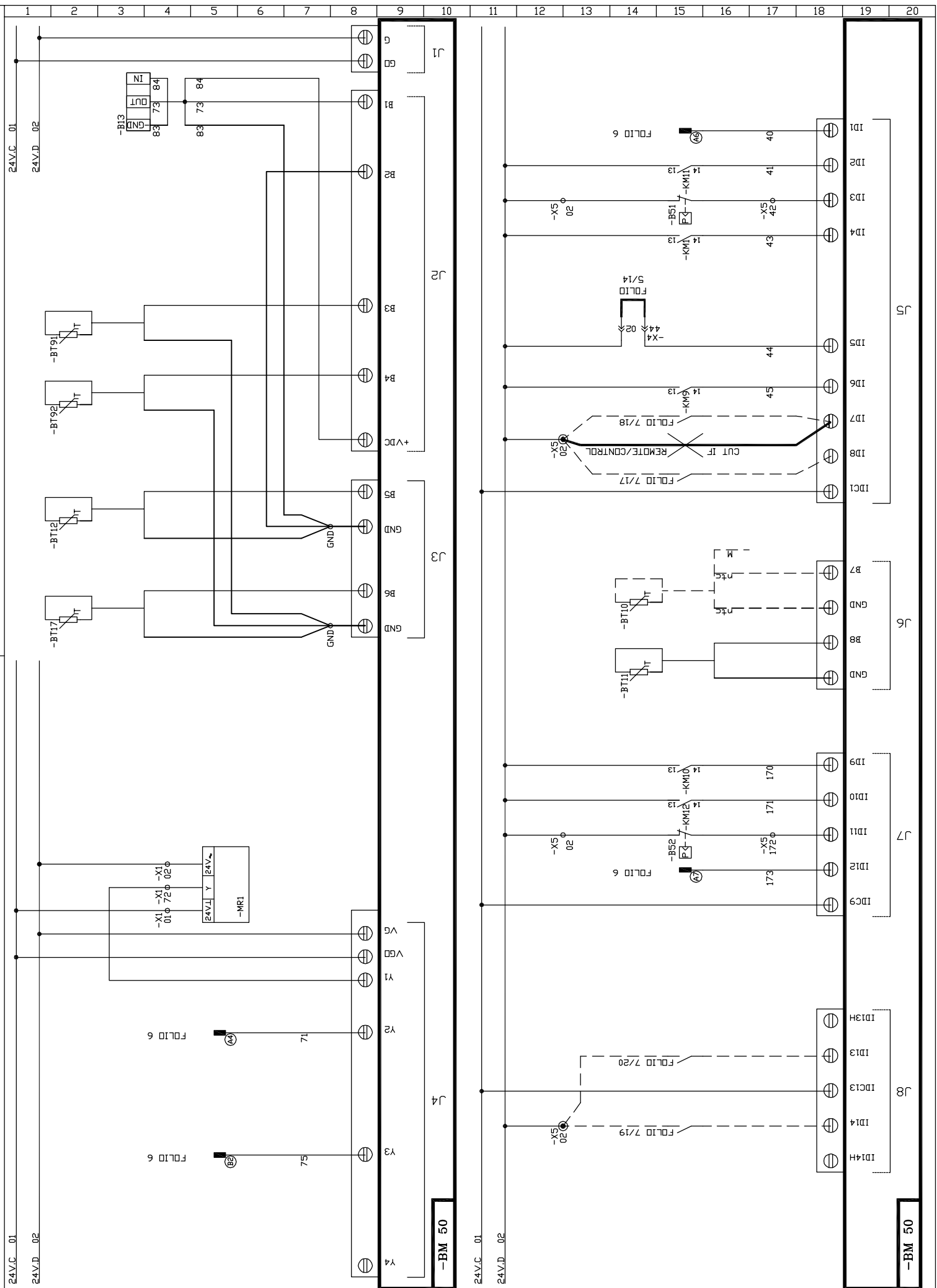

Indice	DATE	NOM	MODIFICATIONS

(1) FHK 190 N
Entrées Automate CLIMATIC 50
Climatic 50 Controller Input

Dessine: T/Y
Date: 18.08.06



249473 3/11

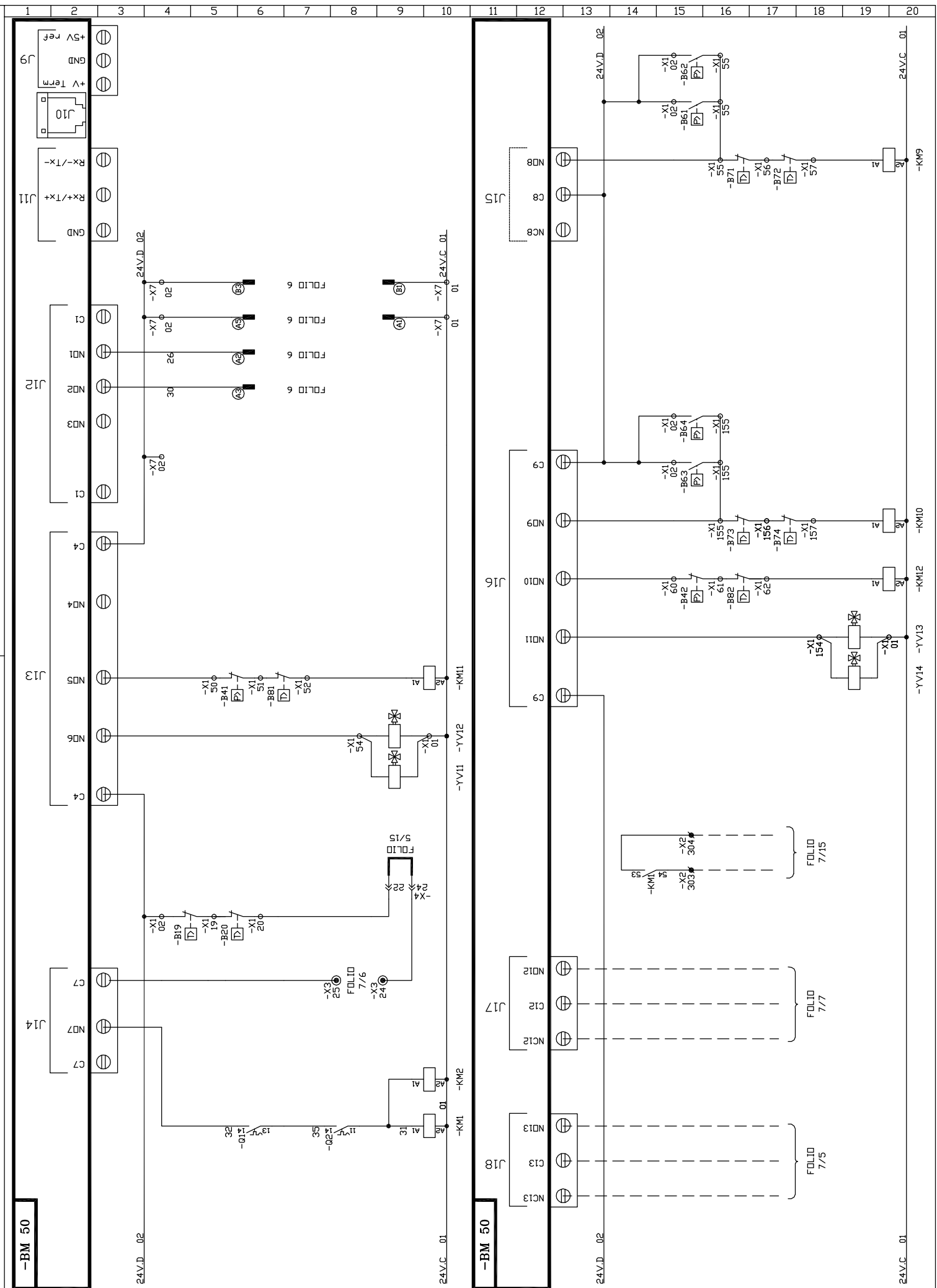

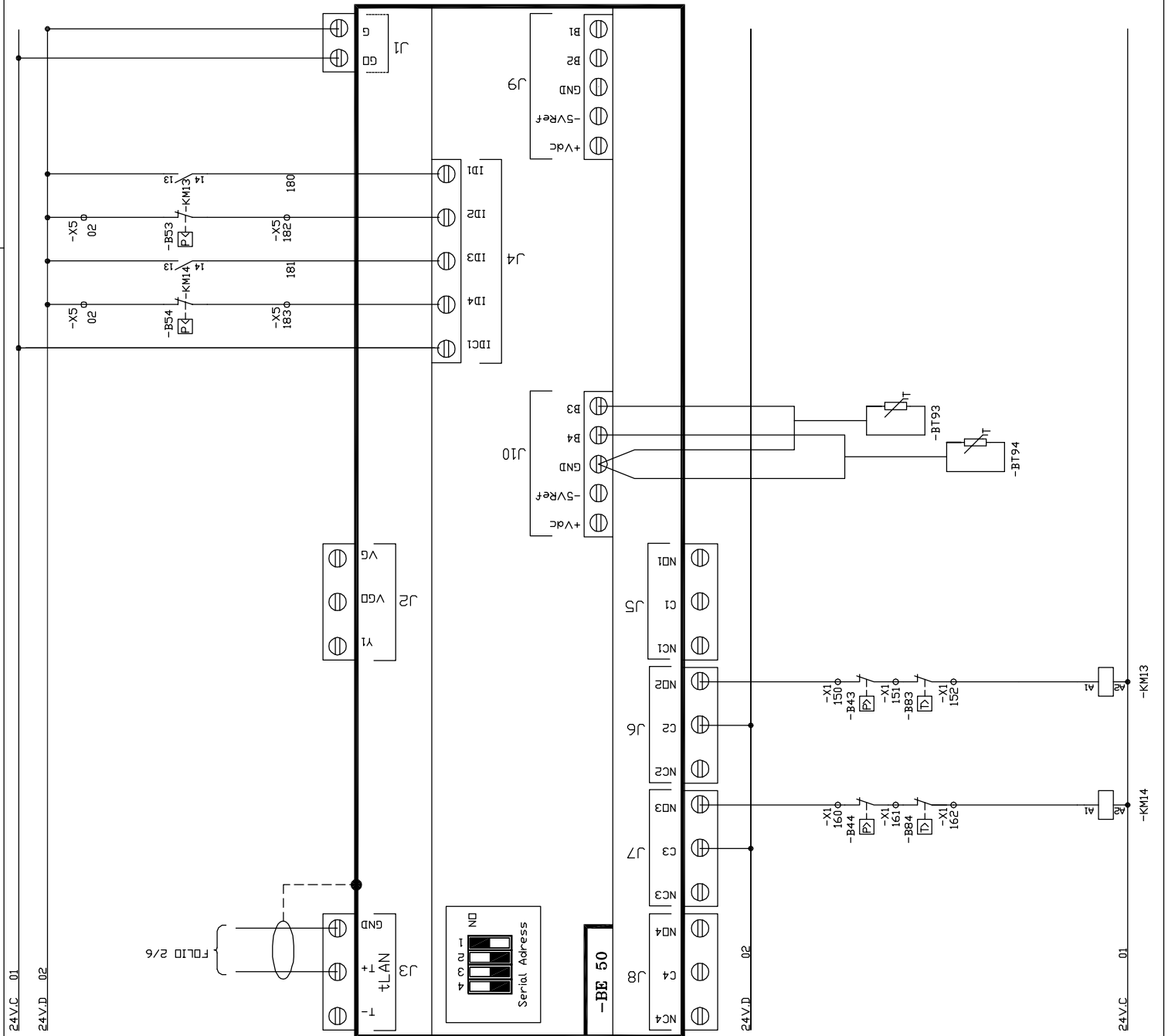
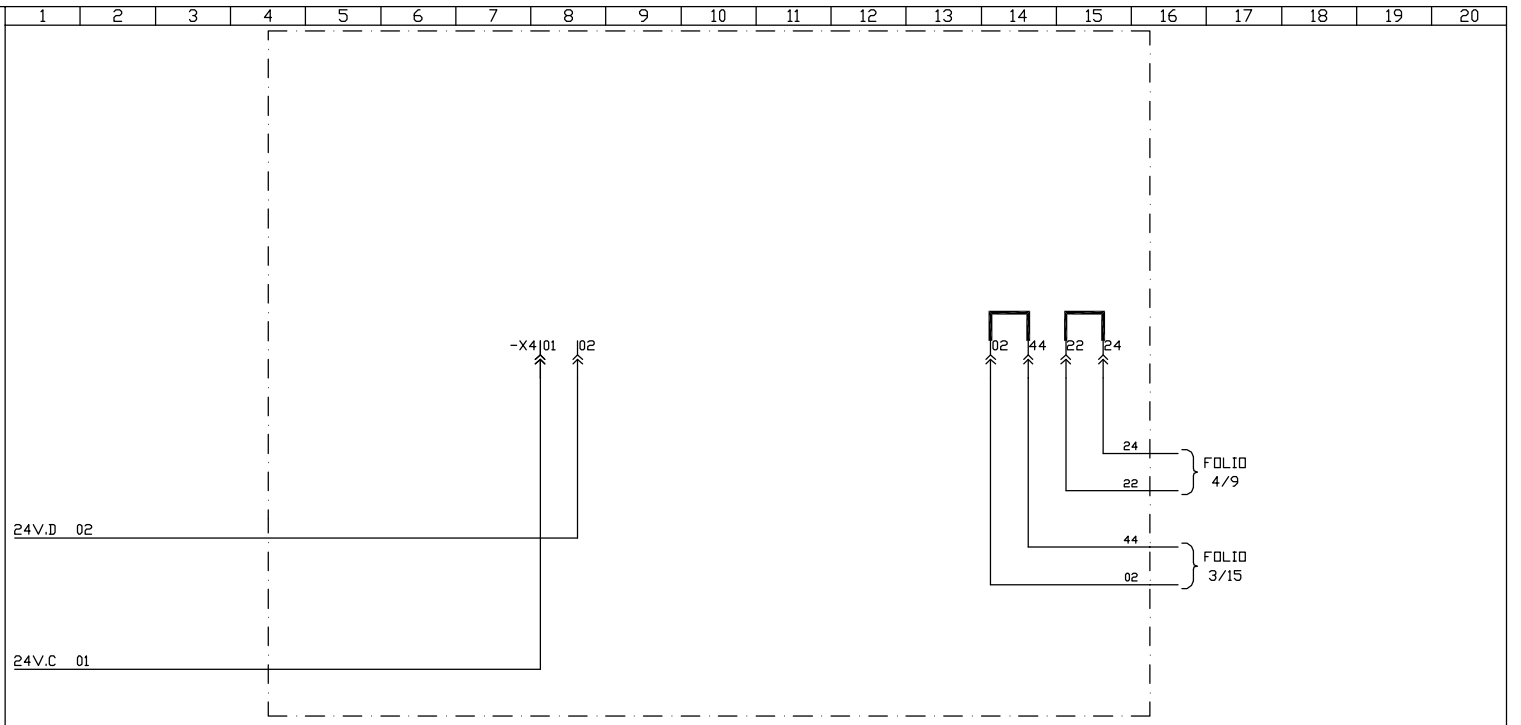

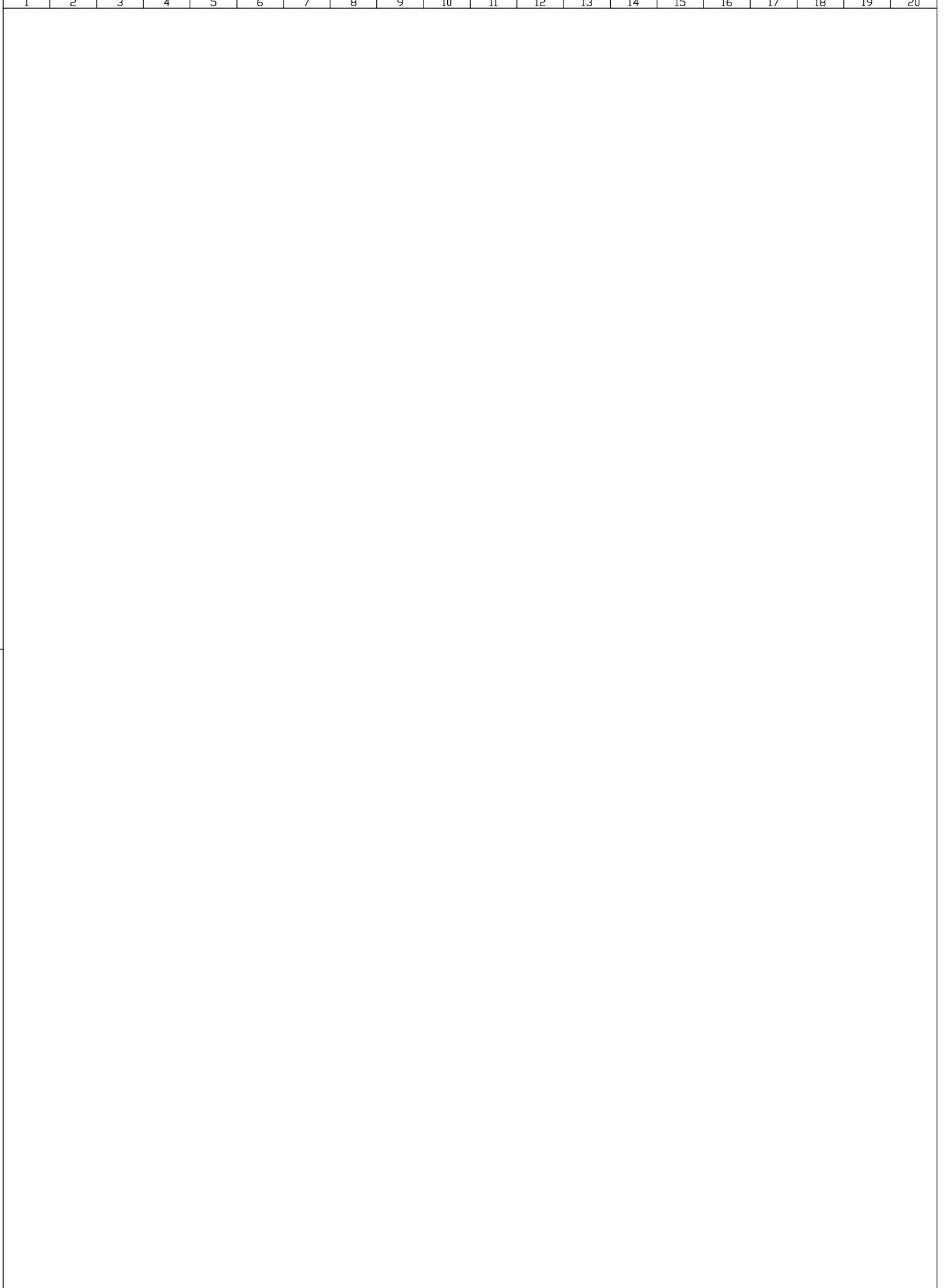

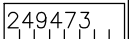
					(1) FHK 190 N Kit chauffage GAS	Dessine: T/Y	 USINE DE LONGVIC	249473	6
Indice	DATE	NOM	MODIFICATIONS			Date: 18.08.06			11

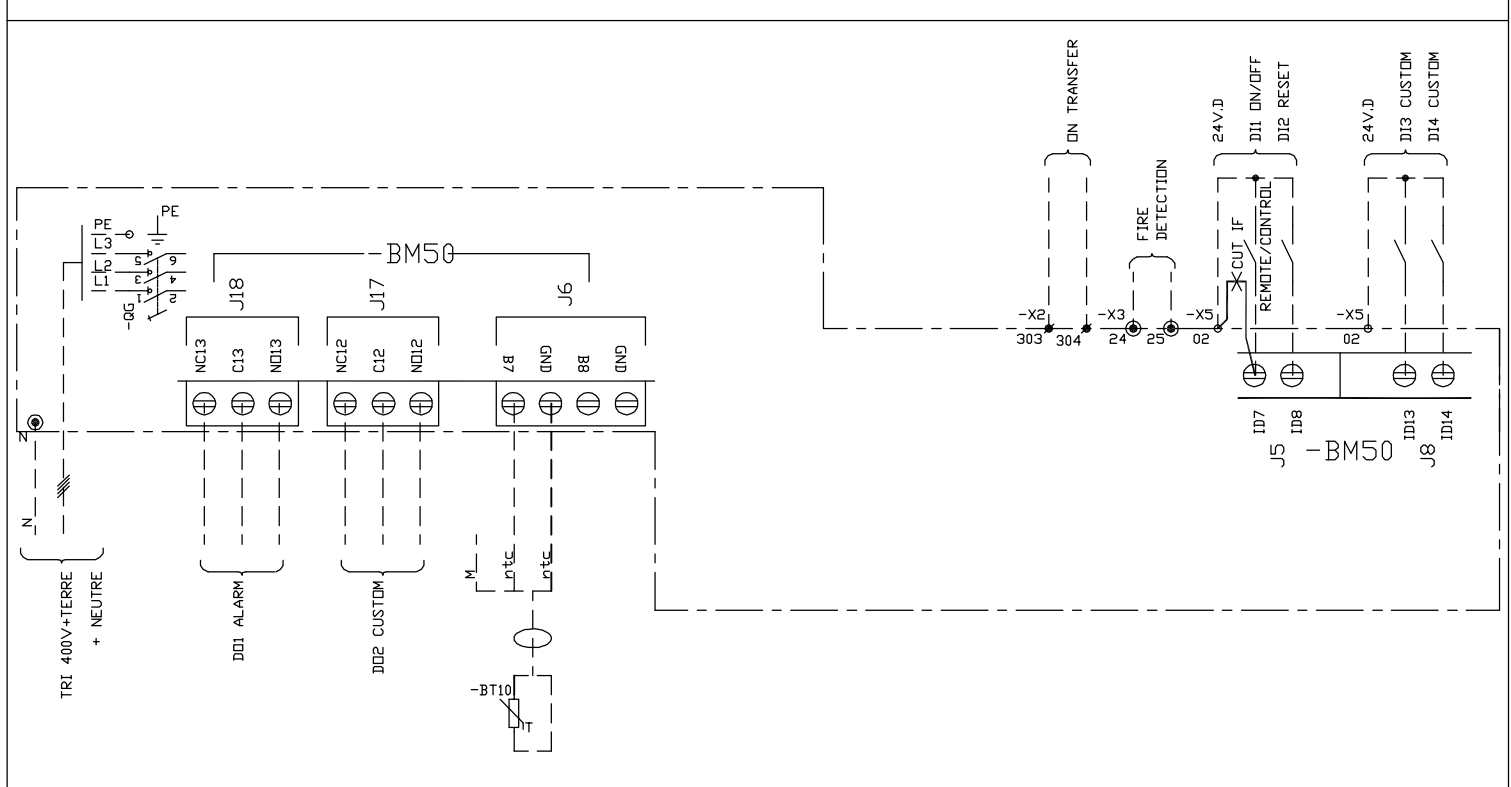
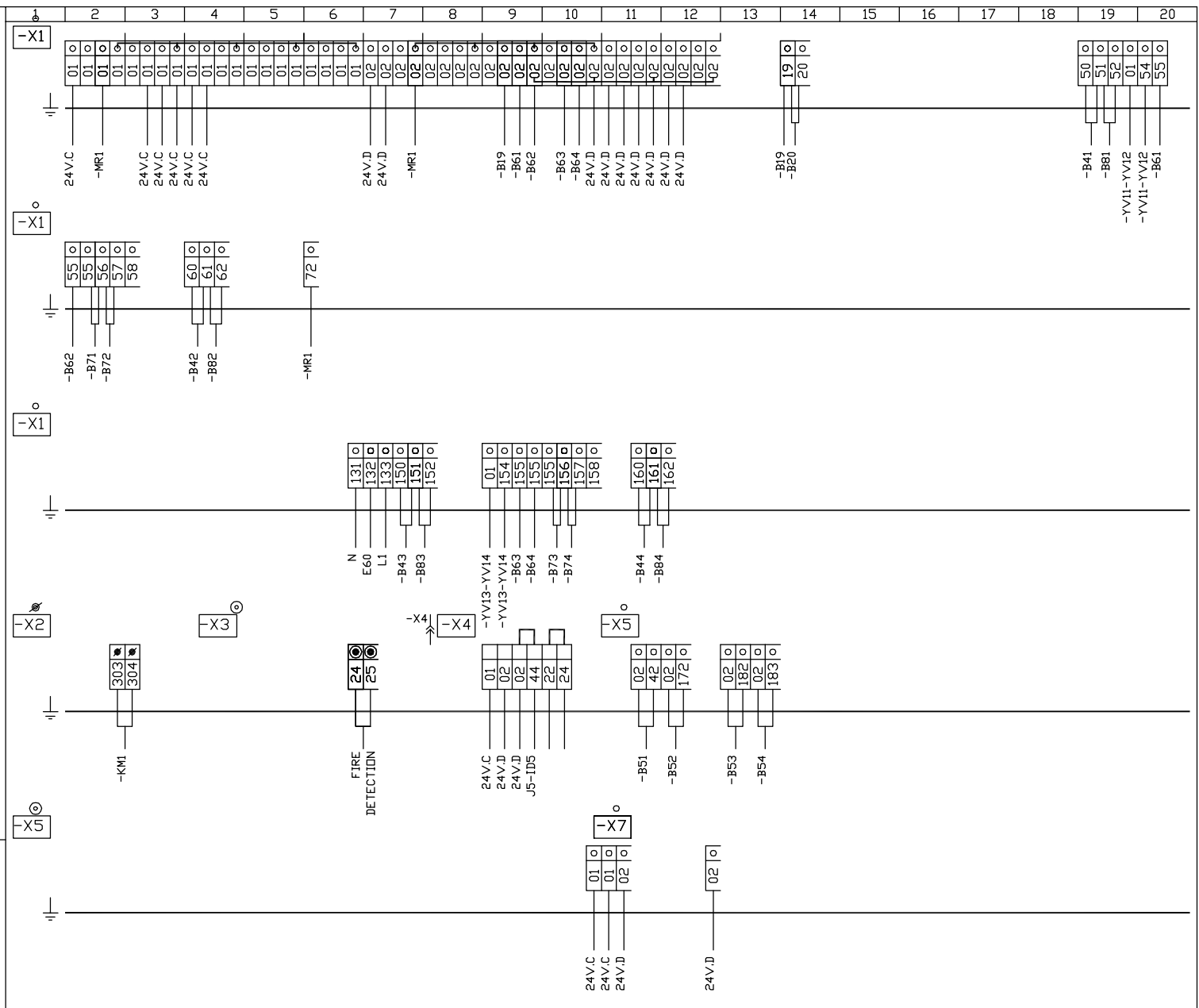

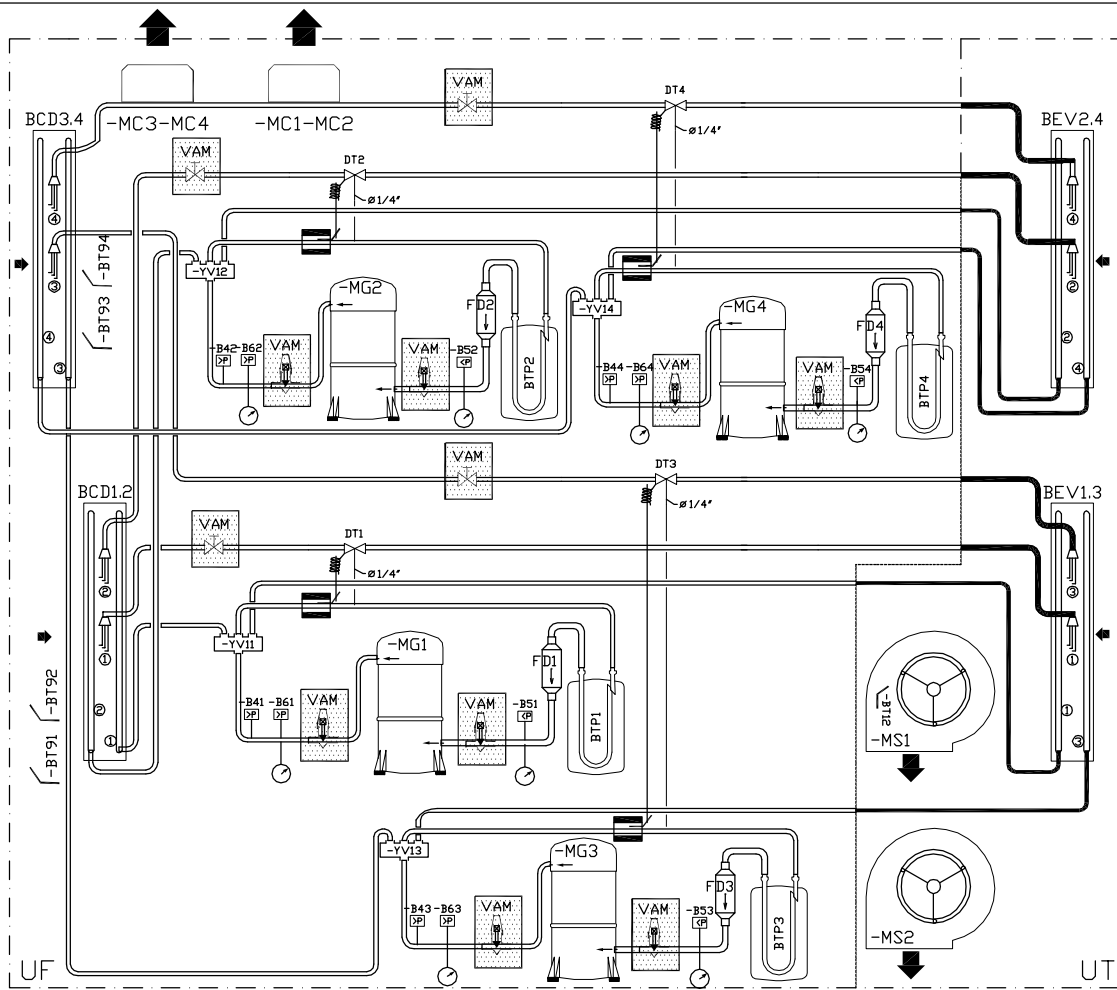

DIAMETRE TUYAUTERIES	
REFOULEMENT	7/8"
ASPIRATION	1 3/8"
LIGNE LIQUIDE	7/8"

TUYAUTERIE CALORIFUGEE
 TUYAUTERIE NON CALORIFUGEE

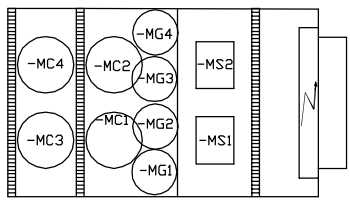
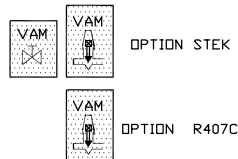

Indice	DATE	NOM	MODIFICATIONS

(1) FHK 190 N
 Schéma Frigorifique \ Hydraulique
 Cooling \ Hydraulic Diagram

Dessine: T/Y
 Date: 18.08.06



249473 9/11

