

Indice	DATE	NOM	MODIFICATIONS
			
<i>Tesco Ryde - AHU Plant</i>			
(2) FDM 150 H	Dessine: T/Y	PAGE DE GARDE	257956 0 / 11
<b>LENNOX UK</b>	Date: 16.11.07		

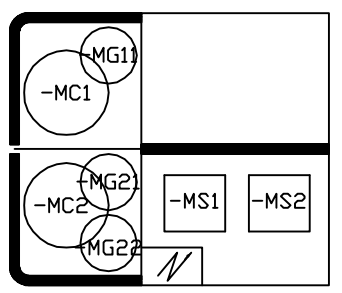

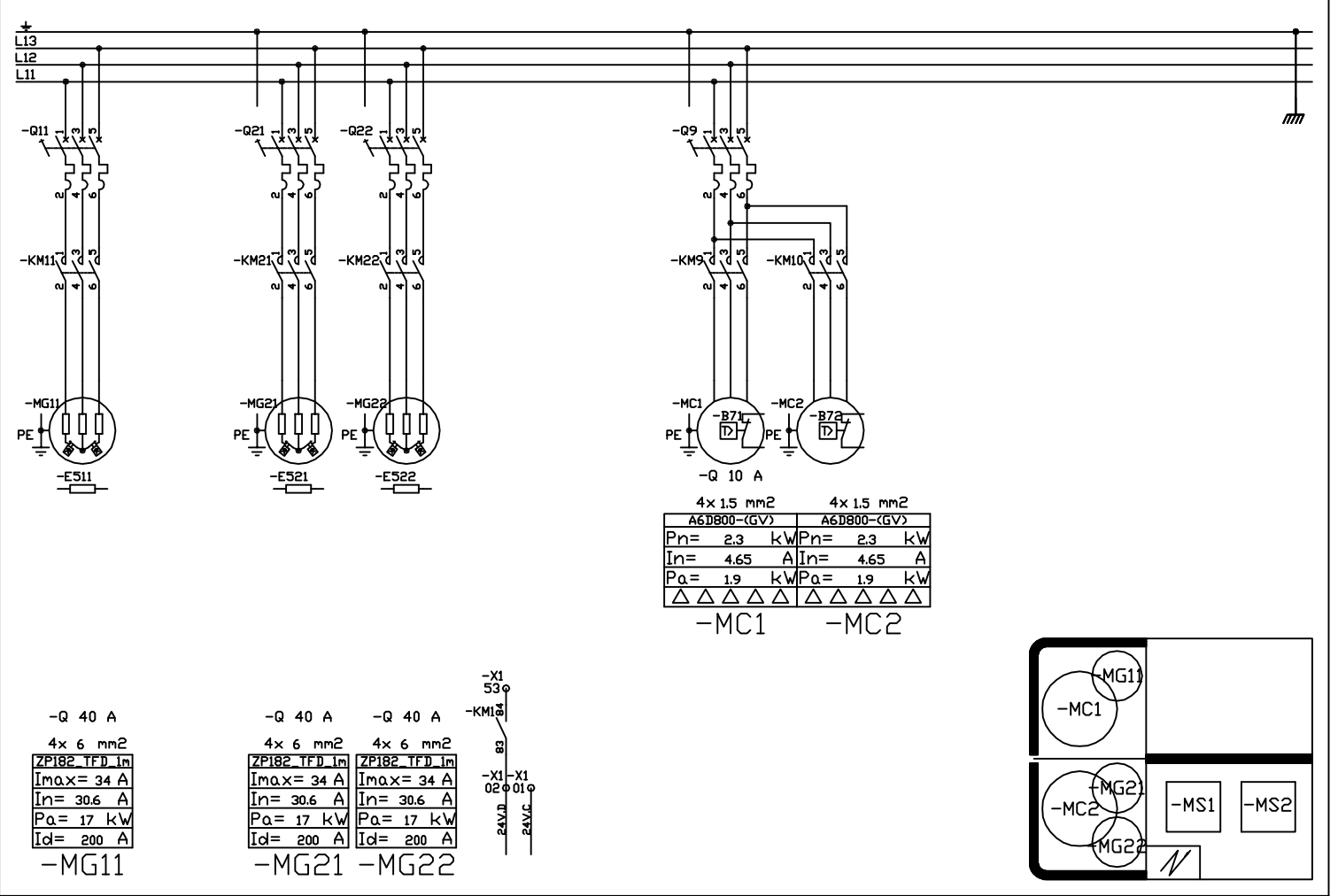

- BM 50

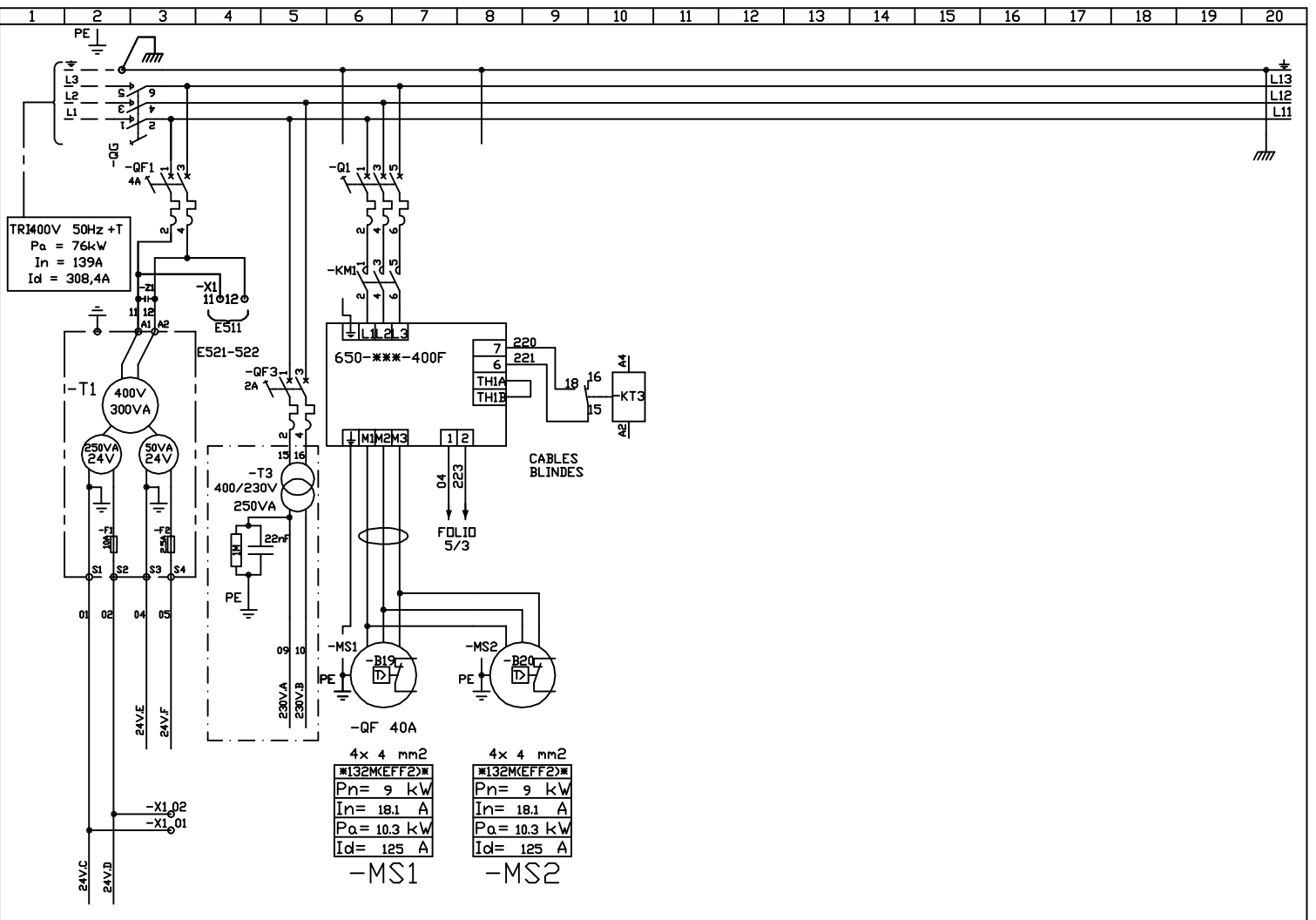
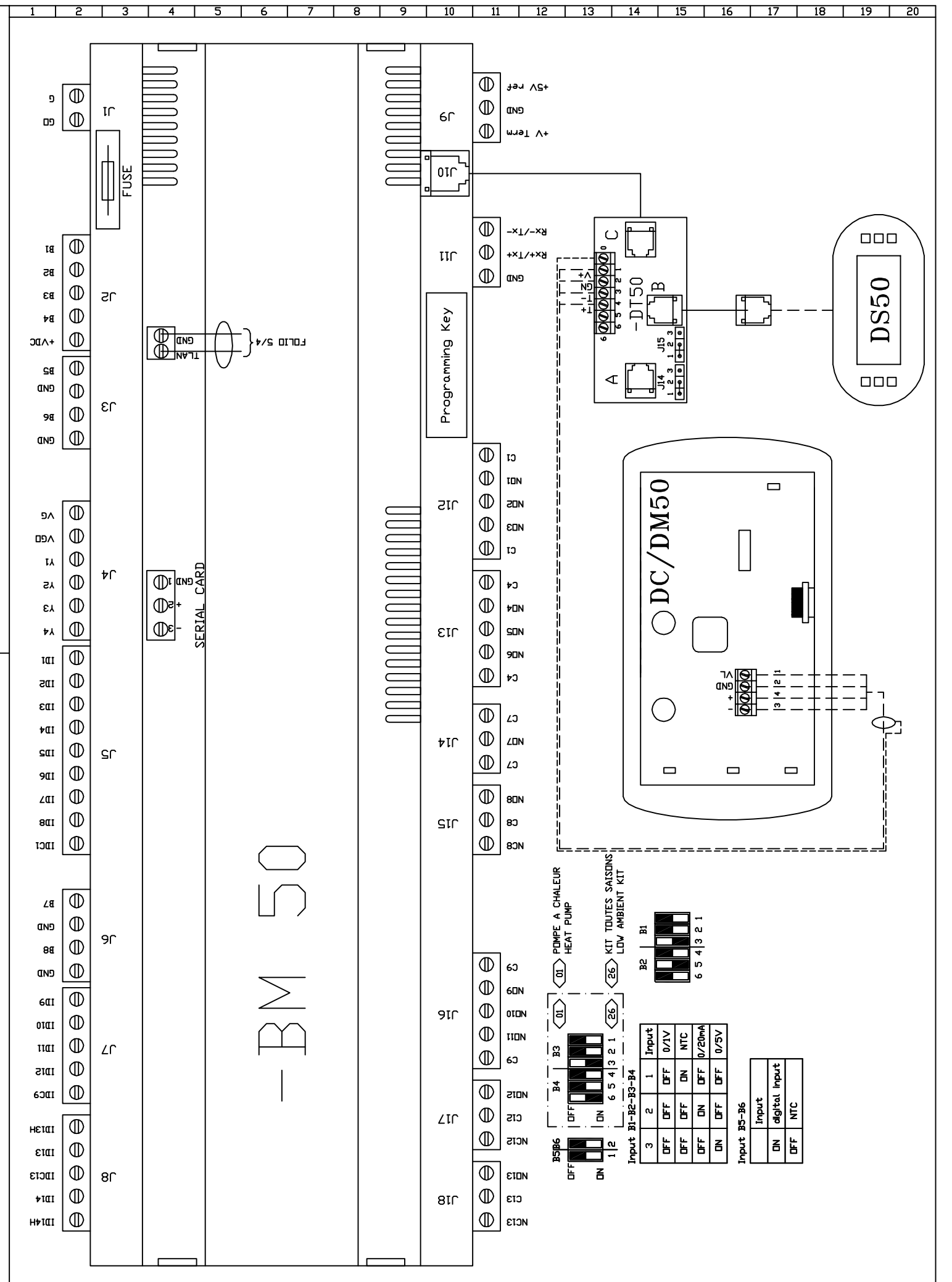
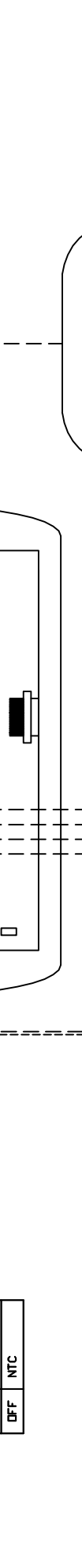
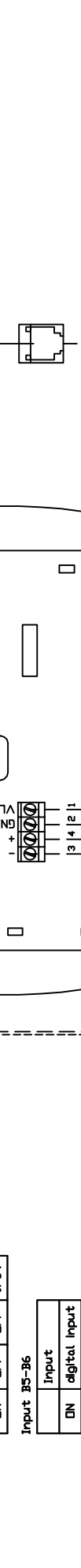
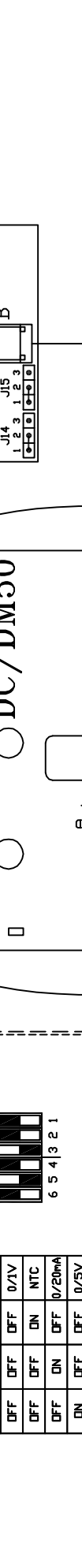
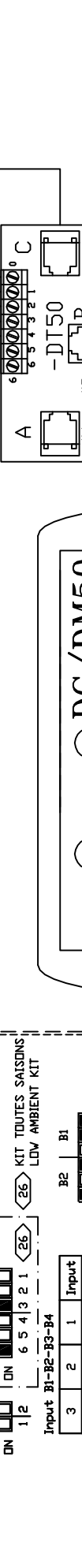
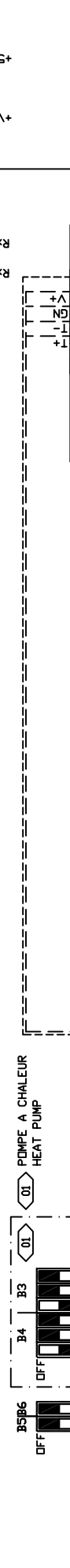
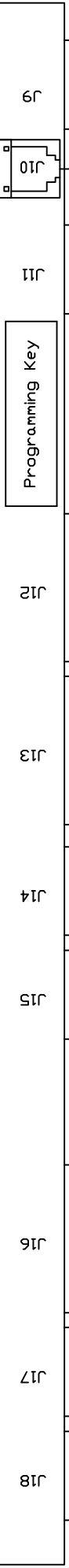
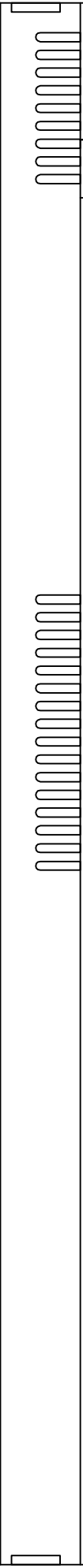
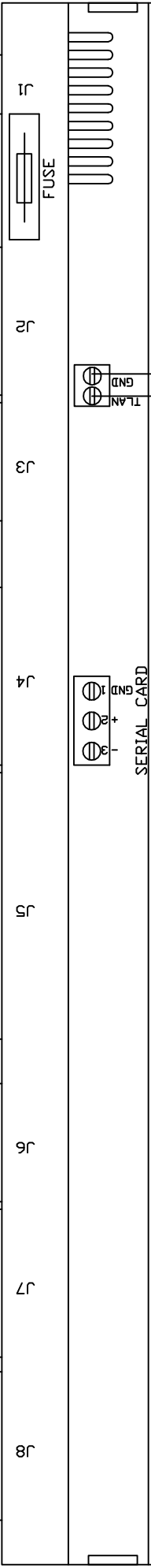
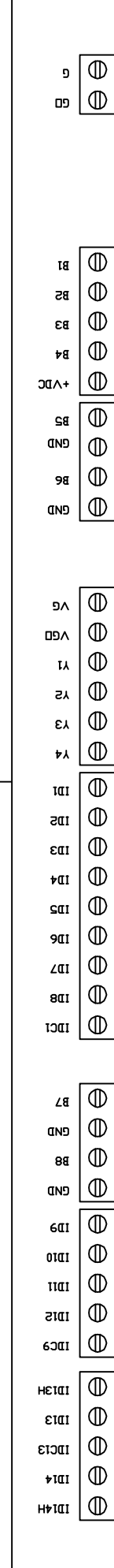

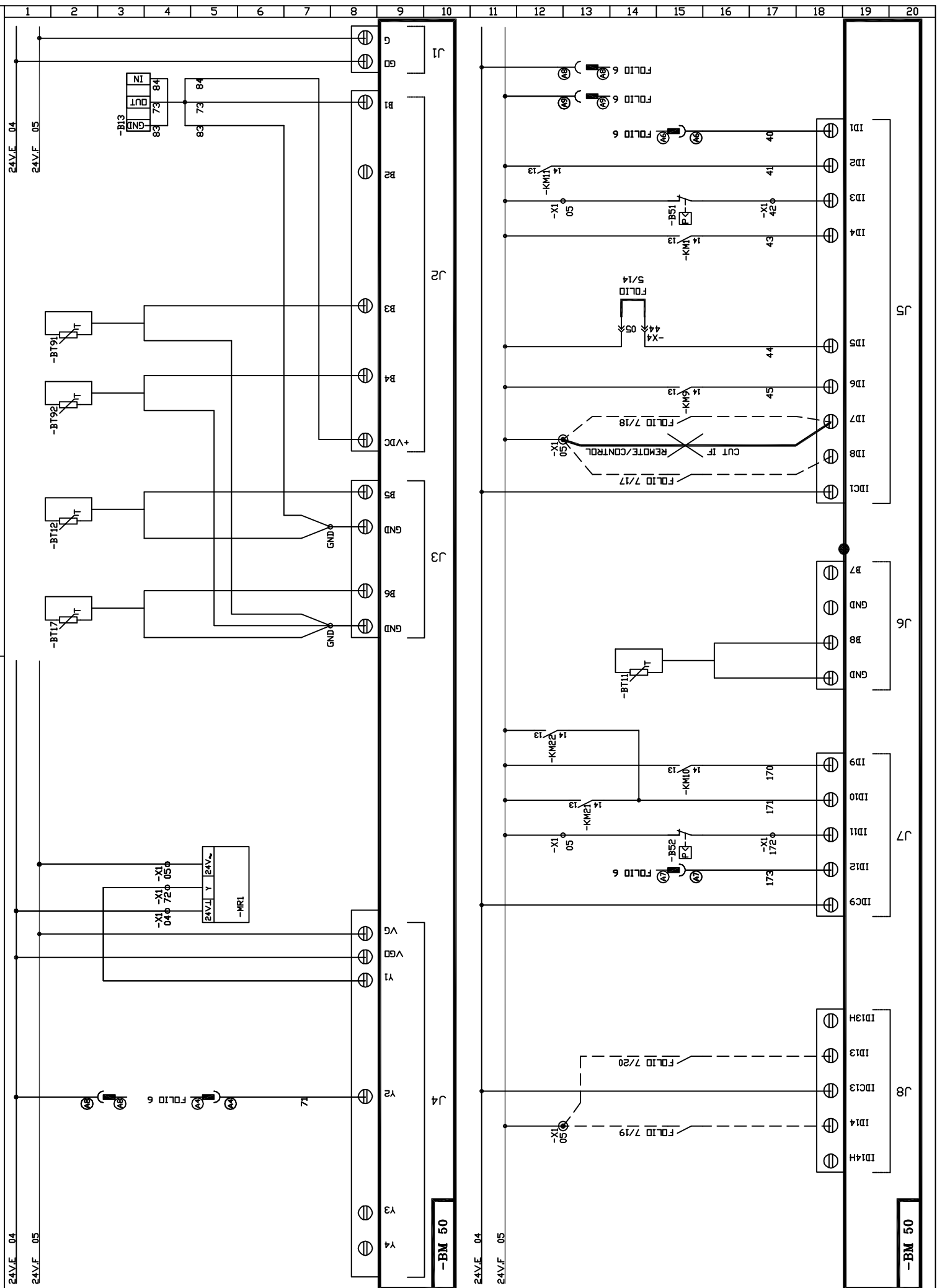

Indice	DATE	NOM	MODIFICATIONS

(2) FDM 150 H  
Entrées Automate CLIMATIC 50  
Climatic 50 Controller Input

Dessine: T/Y  
Date: 16.11.07



257956 3/11

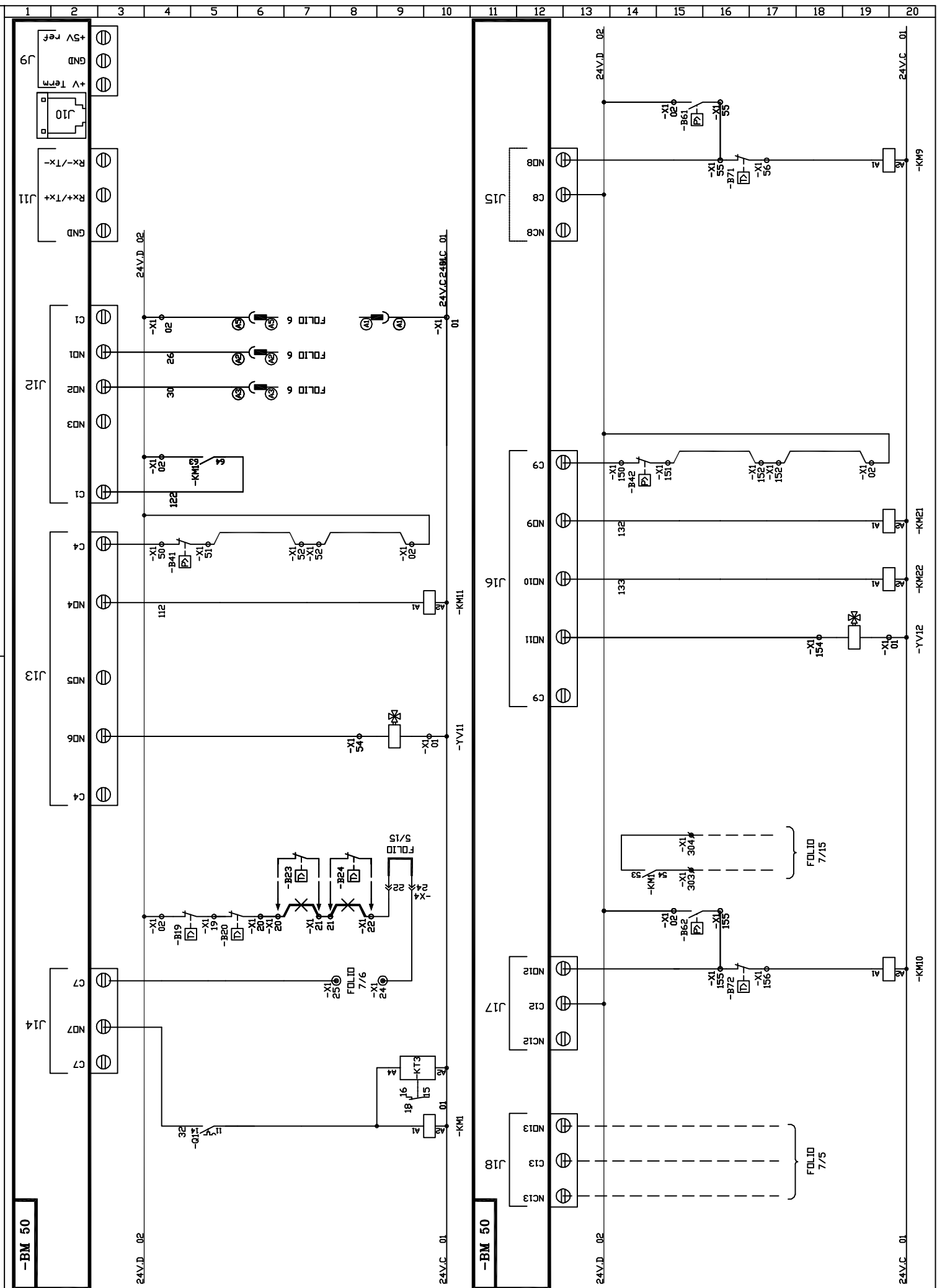

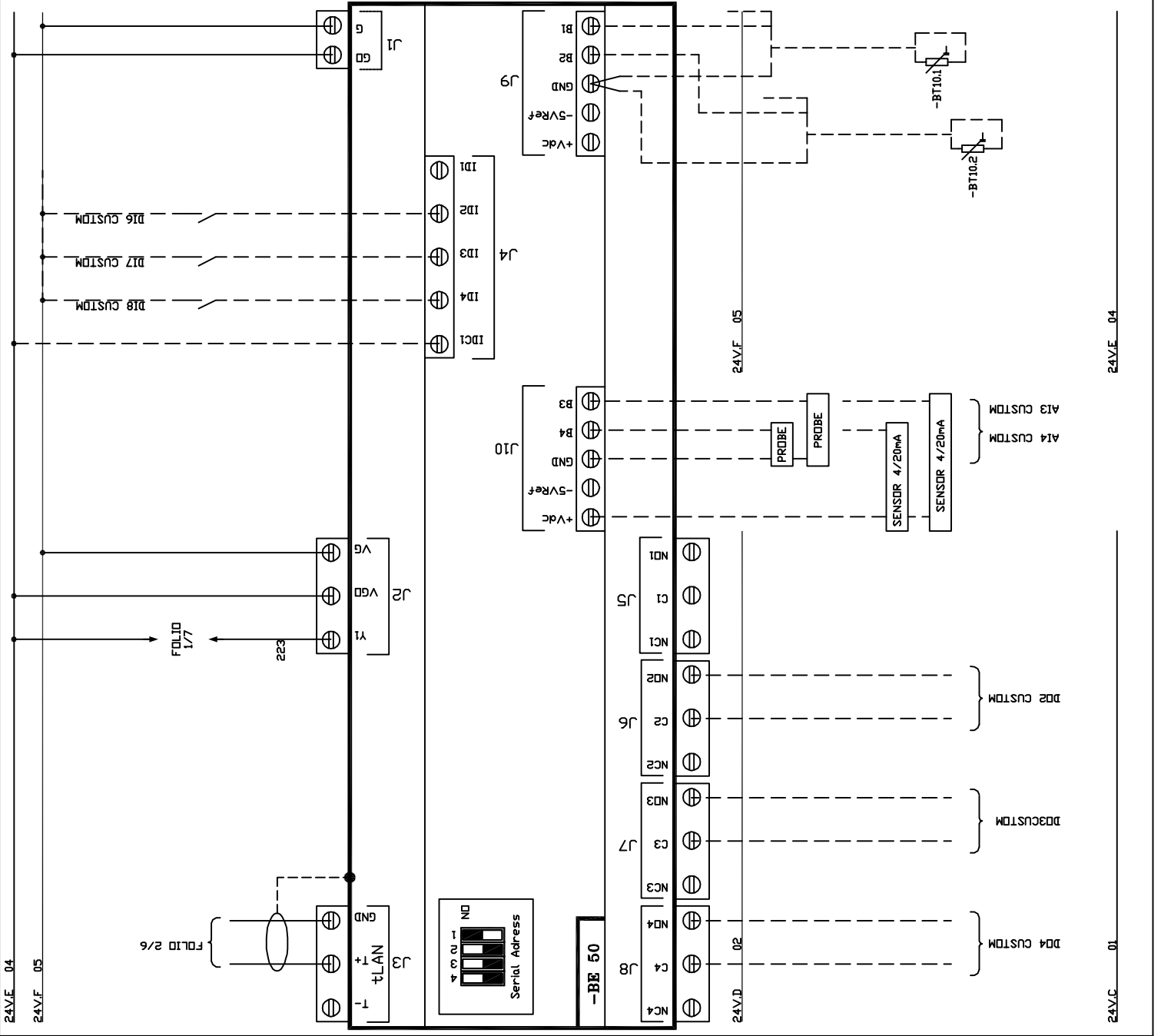
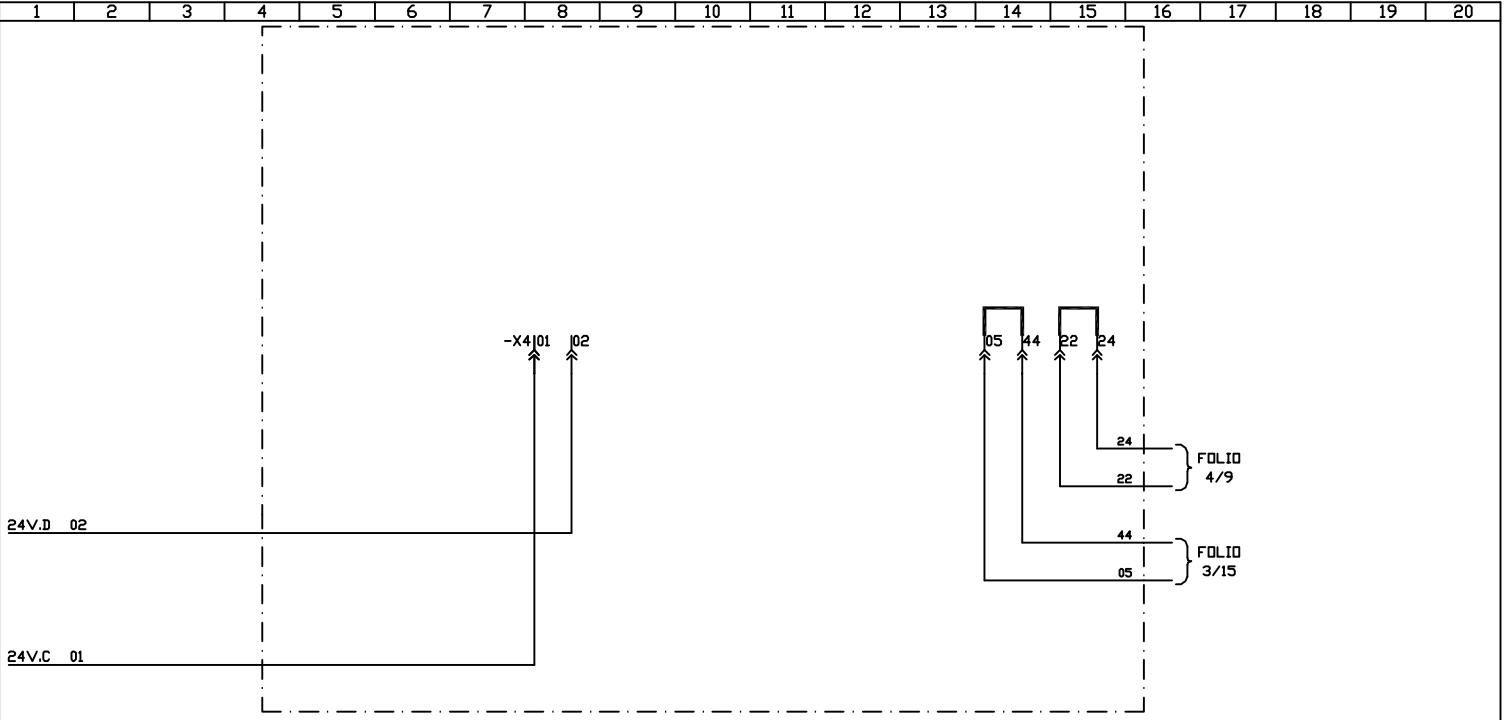

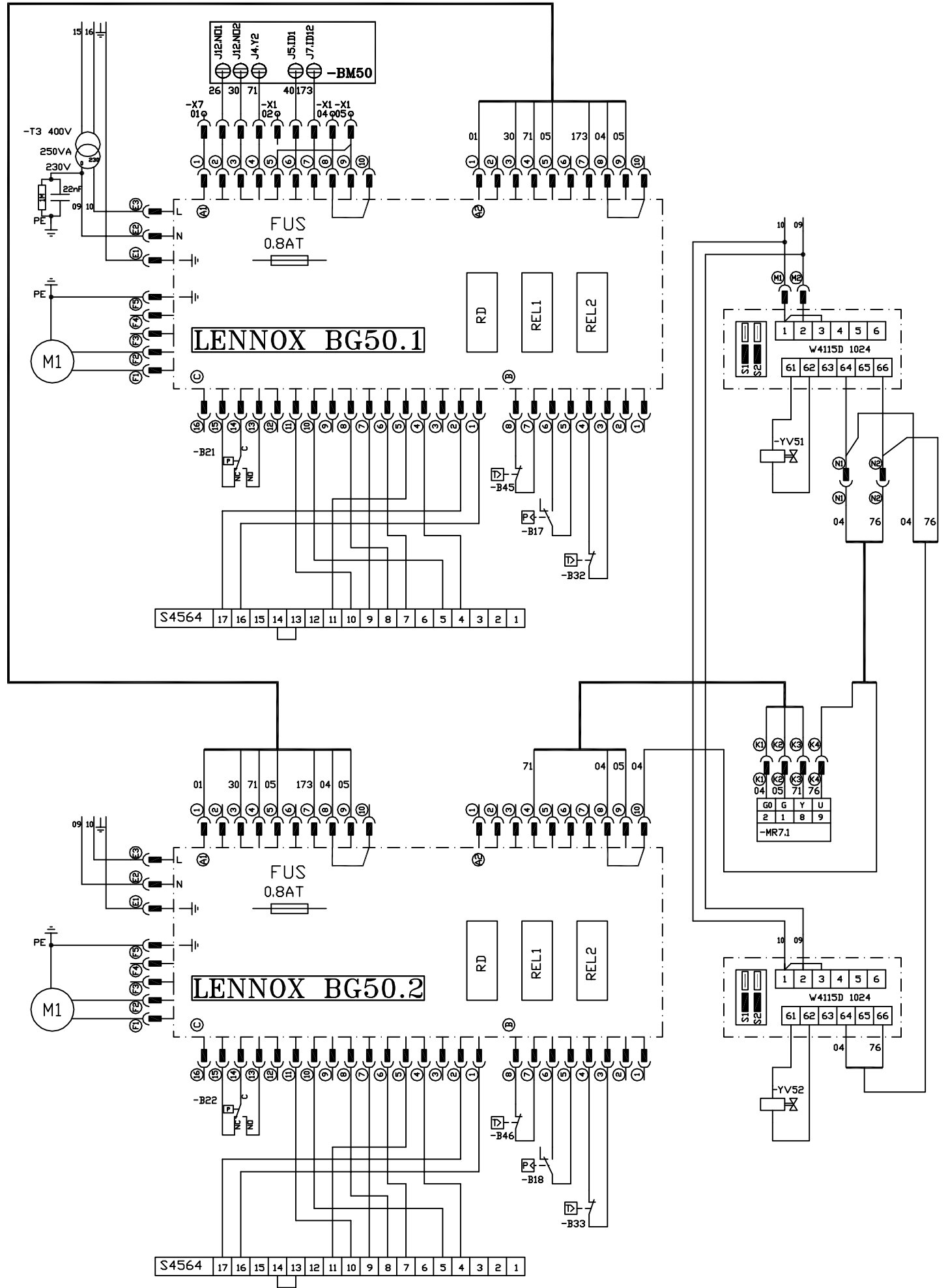

Indice	DATE	NOM	MODIFICATIONS

(2) FDM 150 H  
Kit chauffage  
GAS

Dessiné: T/Y  
Date: 16.11.07



257956 6/11

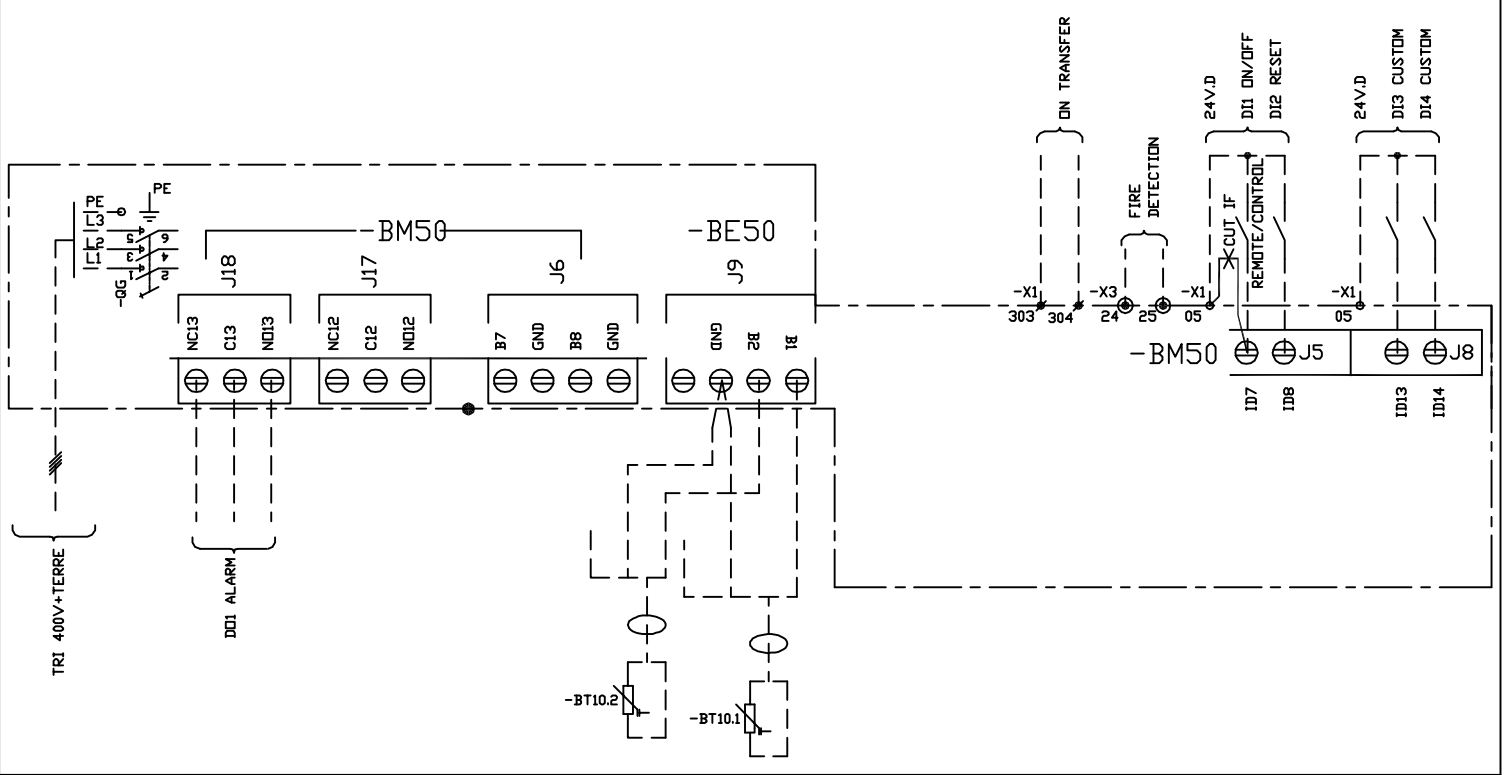
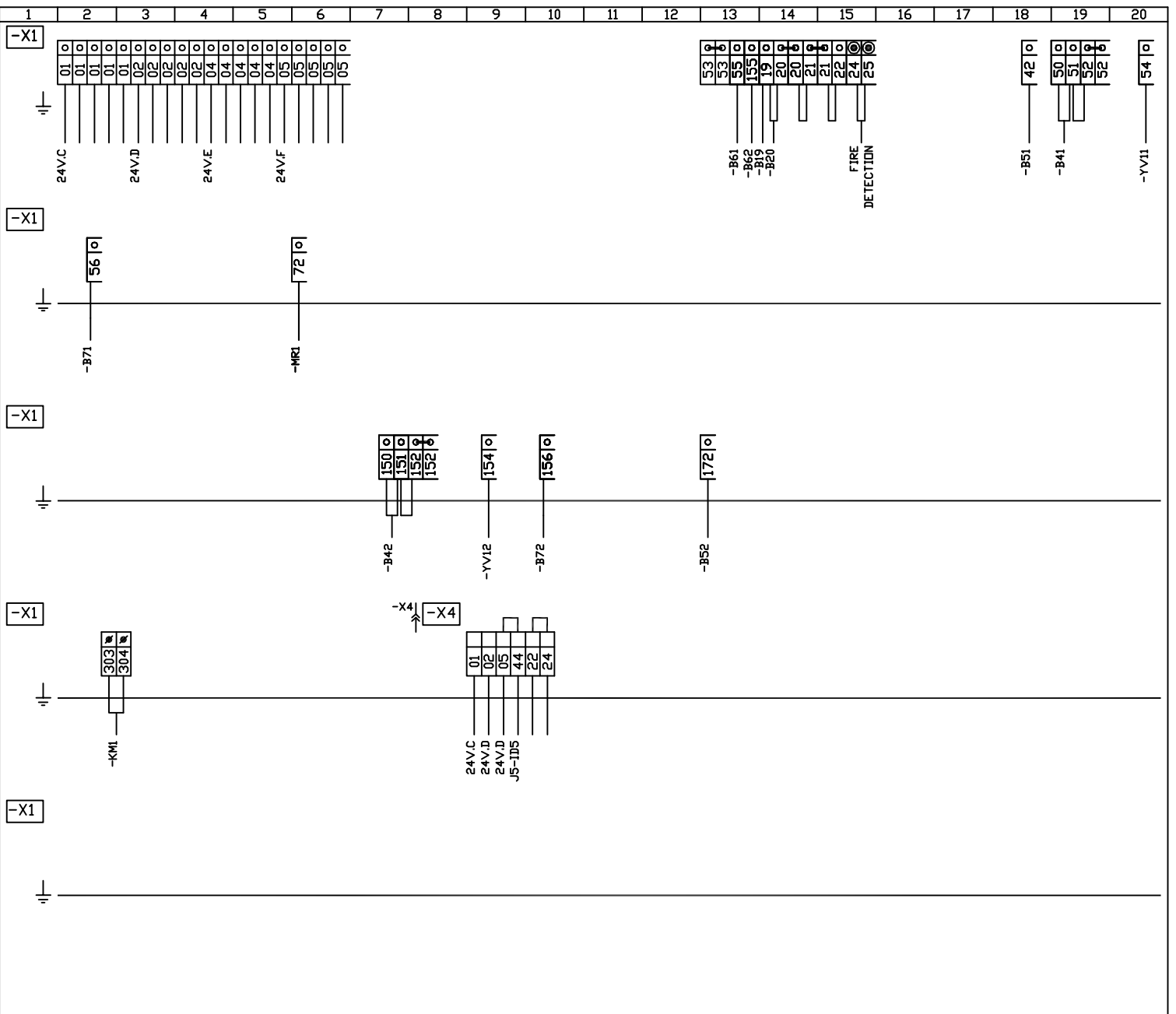



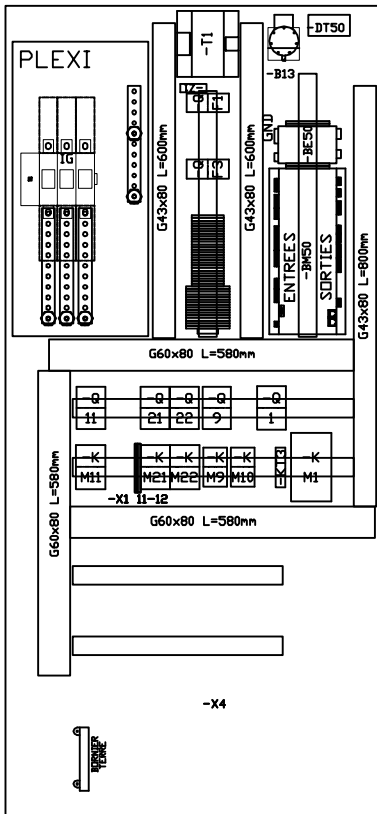

REPERE	REFERENCE	CODE	Nb
-QG	INTER DT 200 E03	4480682P	1
-QG	POIGNEE	4480668W	1
-QG	CACHE BORNES DTS 250 GIL/3	4480699P	1
-QG	AXE DXP6x210	4480686W	1
-QG	ISOLATEUR ISD 30 M6 REF:551440	5480311J	4
-QG	PLAT CU 25x5 LONG:220mm	5480307Z	1
-QG	PLAT CU 25x5 LONG:220mm	5480307Z	3
-QG	ISOLATEUR ISD 30 M6 REF:551440	5480311J	6
-QG	Plexi de protection	77570134	1
-Q1	C60N 40A TRIPOL COURBE D	4480500X	1
-Q1	CONTACT AUX 26924	5480156F	1
-KM1	LC1 D4010 B7	4410655K	1
-KM1	LA1 DN40	5410087M	1
-KT3	88 865 105	4480225T	1
-QF3	C60N 2A BIPOL COURBE D	4480474K	1
-B13	697 9500010A	4730097A	1
-B13	SUPPORT PLAN N 317211	4148197R	1
-QF1	C60N 24583 4A BIPOL COURBE D	4480591H	1
-T1	300VA 400V/24V/24V	4430136J	1
-Z1	LRC V2-0.22-220/400V	4770010X	1
-KM9	LC1 D09 B7	4410650A	1
-Q21-Q22	C60N 40A TRIPOL COURBE D	4480500X	2
-KM21-KM22	LC1 D32 B7	4410654J	2
-KM10	LC1 D09 B7	4410650A	1

REPERE	REFERENCE	CODE	Nb
	REPARTITEUR DE PHASES	4480175V	2
BARRETTE	TYPE MG 14979	5470186T	1

REPERE	REFERENCE	CODE	Nb
-BMS0	CLIMATIC 50	4770607Z	1
-BE50	Extension CLIMATIC 50	4770615M	1
-DT50	-DT50	4770623Y	1
BORNIER	D2.5/5.SNBT.2L DRANGE	5470163K	2
	PLAQUE DE FERMETURE FED5.2L	5470512X	1
	D2.5/5.2L GRISE	5470200N	**
	PLAQUE DE FERMETURE FED5.2L	5470235P	1
	D2.5/5.4L GRISE 24V.C.D	5470270R	16
	PLAQUE DE FERMETURE FED5.4L	5470273V	1
	LIAISON 4 POLES BJDLS.4	5470275Y	2
-Q11	C60N 40A TRIPOL COURBE D	4480500X	1
-KM11	LC1 D32 B7	4410654J	1
-Q9	C60N 10A TRIPOL COURBE D	4480495P	1
-KM9	LC1 D09 B7	4410650A	1
-Q21-Q22	C60N 40A TRIPOL COURBE D	4480500X	2
-KM21-KM22	LC1 D32 B7	4410654J	2
-KM10	LC1 D09 B7	4410650A	1

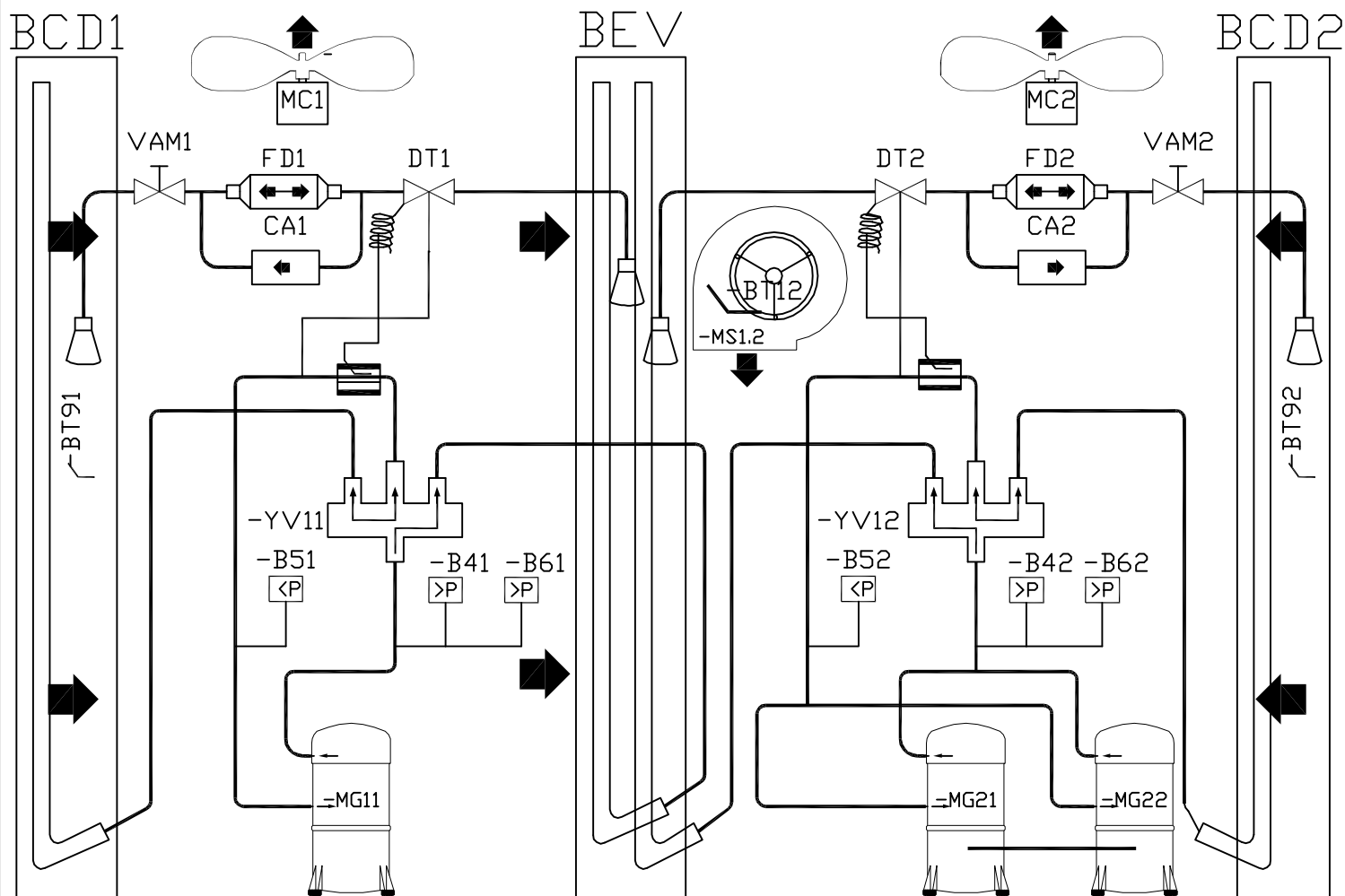

Indice	DATE	NOM	MODIFICATIONS

(2) FDM 150 H  
 Schéma Frigorifique \ Hydraulique  
 Cooling \ Hydraulic Diagram

Dessine: T/Y  
 Date: 16.11.07



257956 9/11



1	2	3	4	5	6	7	8	9	10	11	12	13	14	15	16	17	18	19	20
-A1-2-3-4	AIR SOCK CONTROL																		
-B1	EXTERNAL AIR THERMOSTAT									-KE1-2-3	HEATER	-E1-E2-E3	CONTACTER						
-B2	SMOKE DETECTION HEAD																		
-B3	RC CIRCUIT																		
-B4-B5	GAS MANIFOLD IGNISATION PROBE									-KM1-KM2	BLOWER FAN MOTOR	-MS1-MS2	CONTACTER						
-B6.B7	GAS MANIFOLD IGNITION ELECTRODE																		
-B10	AIR PRESSURE SWITCH									-KM5-KM6	EXTRACTION FAN MOTOR	-ME1-ME2	CONTACTER						
-B11	WATER FLOW RATE CONTROLLER									-KM7	EXTRACTION FAN MOTOR	LOW SPEED	CONTACTER						
-B13	CLOGGED AIR FILTER PRESSURE SWITCH / AIR FLOW RATE									-KM8	STAR COUPLING	CONTACTER							
-B14	HOT WATER BATTERY ANTIFREEZE THERMOSTAT									-KM9-KM10	CONDENSER 1 / CONDENSER 2	FAN MOTOR	CONTACTER						
-B15	HOT WATER BATTERY ANTIFREEZE THERMOSTAT									-KM11-KM12	COMPRESSOR	-MG11-MG12	CONTACTER						
-B16	FIRE THERMOSTAT									-KM21-KM22	COMPRESSOR	-MG21-MG22	CONTACTER						
-B17-B18	GAS MANIFOLD MINIMUM GAS PRESSURE SWITCH																		
-B19-B20	BLOWER FAN MOTOR -MS1-MS2 STOP THERME																		
-B21-B22	GAS MANIFOLD SMOKE EXTRACTION AIR PRESSURE SWITCH																		
-B23-B24	EXTRACTION FAN MOTOR -ME1-ME2 STOP THERME																		
-B25-B26	ELECTRIC BATTERY -E1-E2 SAFETY KLIXON																		
-B27	ELECTRIC BATTERY -E3 SAFETY KLIXON																		
-B28	CIRCULATION PUMP -MP1 MOTOR STOP THERME																		
-B29-B30	GAS MANIFOLD AIR FLOW RATE SAFETY KLIXON									-MC1.2	CONDENSER	-MC1-MC2	FAN MOTOR						
-B31	EXTRACTION FAN MOTOR -ME3 STOP THERME									-MC3.4	CONDENSER	-MC3-MC4	FAN MOTOR						
-B32-B33	GAS MANIFOLD FLASHBACK SAFETY KLIXON									-ME1-ME2	EXTRACTION FAN MOTOR	-ME1-ME2							
-B41-B42	COMPRESSOR -MG11-12/-MG21-22 HIGH PRESSURE SAFETY SWITCH									-MG11-MG12	COMPRESSOR	-MG11-MG12							
-B45-B46	GAS MANIFOLD 1 / GAS MANIFOLD 2 REGULATION KLIXON									-MG21-MG22	COMPRESSOR	-MG21-MG22							
-B51-B52	COMPRESSOR -MG11-12/-MG21-22 LOW PRESSURE SAFETY SWITCH									-MR1	ECONOMISER DAMPER MOTOR								
-B61-B62	COMPRESSOR -MG11-12/-MG21-22 HIGH PRESSURE CONTROL SWITCH									-MR2	BLOWER DAMPER MOTOR								
-B71-B72	CONDENSER -MC1-MC2 FAN MOTOR STOP THERME									-MR3	NEW AIR DAMPER MOTOR								
-B73-B74	CONDENSER -MC3-MC4 FAN MOTOR STOP THERME									-MR4	EXTRACTION DAMPER MOTOR								
-B811-B812	SCROLL COMPRESSOR -MG11-12 PROTECTION MODULE									-MR6	BY-PASS DAMPER MOTOR								
-B821-B822	SCROLL COMPRESSOR -MG21-22 PROTECTION MODULE									-MS1-MS2	BLOWER FAN MOTOR	-MS1-MS2							
-B91-B92	COMPRESSOR -MG11-12/-MG21-22 PRESSURE SWITCH 4/20mA									-Q1-Q2	BLOWER FAN MOTOR	-MS1-MS2	PROTECTION						
-B831-B832	THERMOSTAT OF COMPRESSING REPRESSION									-Q5-Q6	EXTRACTION FAN MOTOR	-ME1-ME2	PROTECTION						
-B841-B842	THERMOSTAT OF COMPRESSING REPRESSION									-Q8	HEAT RECOVERY MODULE	PROTECTION							
BCD	CONDENSER BATTERY									-Q9	CONDENSER -MC1-MC2	FAN MOTOR	PROTECTION						
BEC	HOT WATER BATTERY									-Q10	CONDENSER -MC3-MC4	FAN MOTOR	PROTECTION						
BEG	CHILLED WATER BATTERY									-Q11-Q12	COMPRESSOR	-MG11-MG12	PROTECTION						
BEV	EVAPORATOR BATTERY									-Q21-Q22	COMPRESSOR	-MG21-MG22	PROTECTION						
-BG10	HYGIENE PROBE									-QF1	PRIMARY CIRCUIT	PROTECTION	-T1						
-BH10	REGULATION HYGROMETRY PROBE									-QF2	PRIMARY CIRCUIT	PROTECTION	-T2						
-BH11	EXTERNAL HYGROMETRY PROBE									-QF3	PRIMARY CIRCUIT	PROTECTION	-T3						
-BT10	REGULATION TEMPERATURE PROBE									-QF4	PRIMARY CIRCUIT	PROTECTION	-T4						
-BT11	EXTERNAL TEMPERATURE PROBE									-QG-QG1	MAIN SWITCH								
-BT12	BLOWER TEMPERATURE PROBE																		
-BT13	COLD WATER TEMPERATURE PROBE									-QE1-2-3	HEATER	-E1-E2-E3	PROTECTION						
-BT14	CONDENSER 1 SPEED REGULATION TEMPERATURE PROBE																		
-BT15	CONDENSER 2 SPEED REGULATION TEMPERATURE PROBE																		
-BT16-BT18	HEAT EXCHANGER WATER OUTLET PROBE																		
-BT17	RETURN TEMPERATURE SENSOR									RL1-2	LIQUID RESERVOIR								
-BT91-BT92	DEFROST TEMPERATURE SENSOR COMPRESSOR -MG11-12/-MG21-22																		
CA1.2.3.4	VALVE ANTI RETURN									-T1	CONTROL CIRCUIT	TRANSFORMER	400V/24V						
DT	THERMOSTATIC HOLDER									-T2	POWER SUPPLY	TRANSFORMER	400 / 230V						
EEV	WATER HEAT EXCHANGER									-T3	BURNER POWER	SUPPLY	TRANSFORMER	400 / 230V					
-E1-E2-E3	HEATER -E1-E2-E3									-T4	BURNER POWER	SUPPLY	TRANSFORMER	400V/24V					
-E7-E8	ANTIFREEZE HEATER CORDS HOT WATER BATTERY									-TCB	CONTROL	THERMOSTAT							
-E9-E10	ANTIFREEZE HEATER CORDS									UF	COOLING UNIT								
-E4	VAPOR HUMIDIFIER									UT	AIR TREATMENT UNIT								
-E11	SMOKE DETECTOR PRINTED CIRCUIT									UV1-UV2	*****								
-E14	BURNER CONTROL BOX									UI	INTERFACE								
-BE 50	EXTENSION BOARD									VAM	MANUAL CHECK VALVE								
-BM 50	CLIMATIC 50									-V1	ELECTRIC BATTERY	STATIC CONTACTER							
-BX 50	MULTIPLEXER CLIMATIC 50									-V2	ELECTRIC BATTERY	STATIC CONTACTER							
-DT 50	CONNECTION BOARD																		
-E32	INTERFACE									-YV1	CHILLED WATER	3-WAY VALVE							
-E511-E512	COMPRESSOR -MG11-12 HOUSING RESISTANCE									-YV2	HOT WATER	3-WAY VALVE							
-E521-E522	COMPRESSOR -MG21-22 HOUSING RESISTANCE									-YV11-YV12	COMPRESSOR	-MG11-MG12/-MG21-MG22	CYCLE REVERSAL VALVE						
FD	DEHUMIDIFIER FILTER									-YV31-YV32	BURNER GAS	SOLENOID VALVE							
FDB	BOTTLE DEHUMIDIFIER FILTER									-YV41-YV42	GAS MANIFOLD	SAFETY SOLENOID VALVE							
FDW	DOUBLE FLOW DEHUMIDIFIER FILTER									-YV51-YV52	GAS MANIFOLD	MAIN SOLENOID VALVE							
-Z*	CAPACITY RESISTANCE CIRCUIT																		

 SCREENED CABLE MARK  
 -FIL 0.5mm2  
 \_\_\_\_\_ LINKS TO BE MADE BY INSTALLER  
 -X1 o MAIN TERMINAL STRIP  
 -X4 | SMOKE DETECTION TERMINAL STRIP  
 ↑