

Indice	DATE	NOM	MODIFICATIONS
			
<i>Bannatynes Cym</i>			
(1) FCK 085 N	Dessine: CTO	PAGE DE GARDE	242354
LENNOX UK	Date: 19.05.05		0 / 11

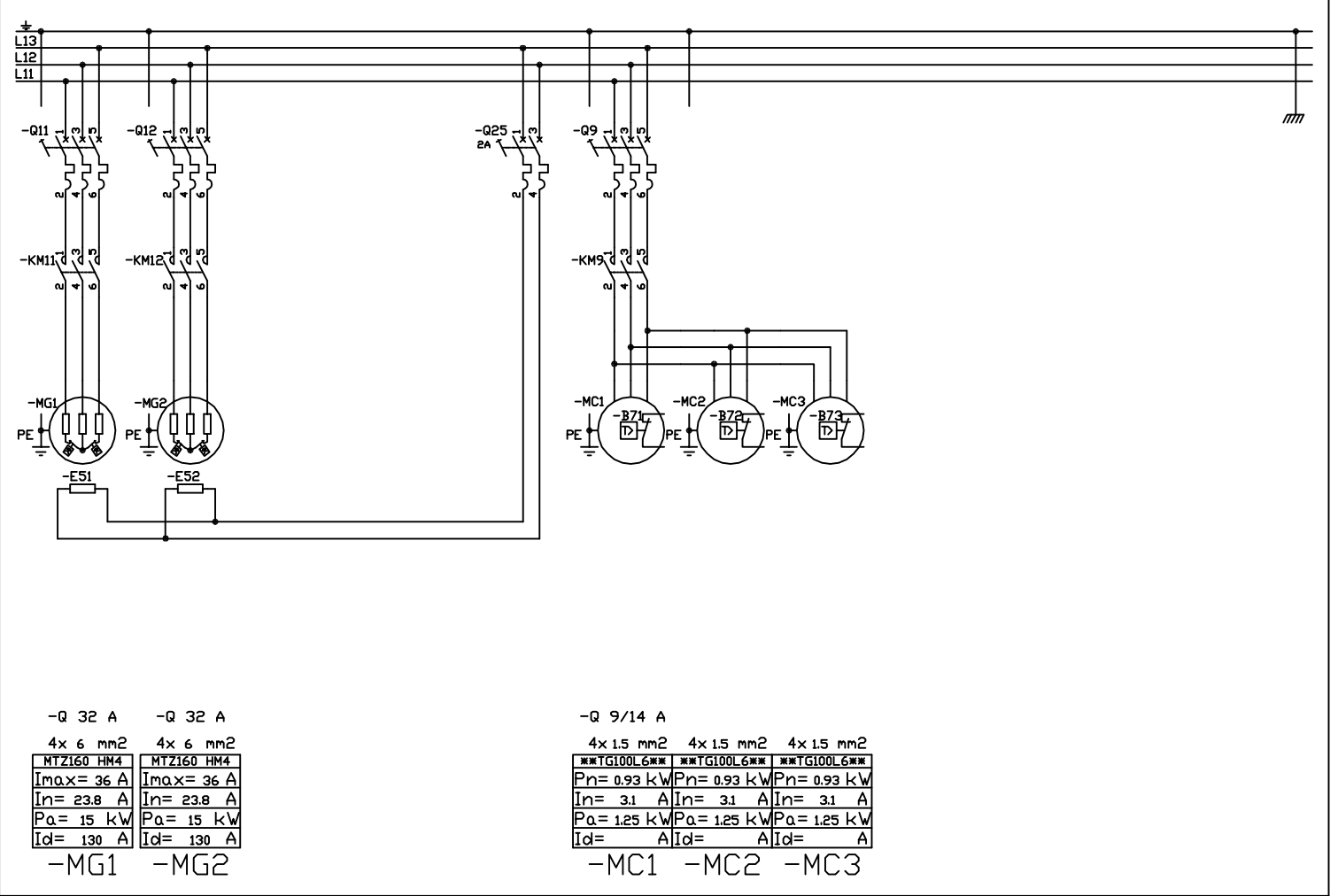

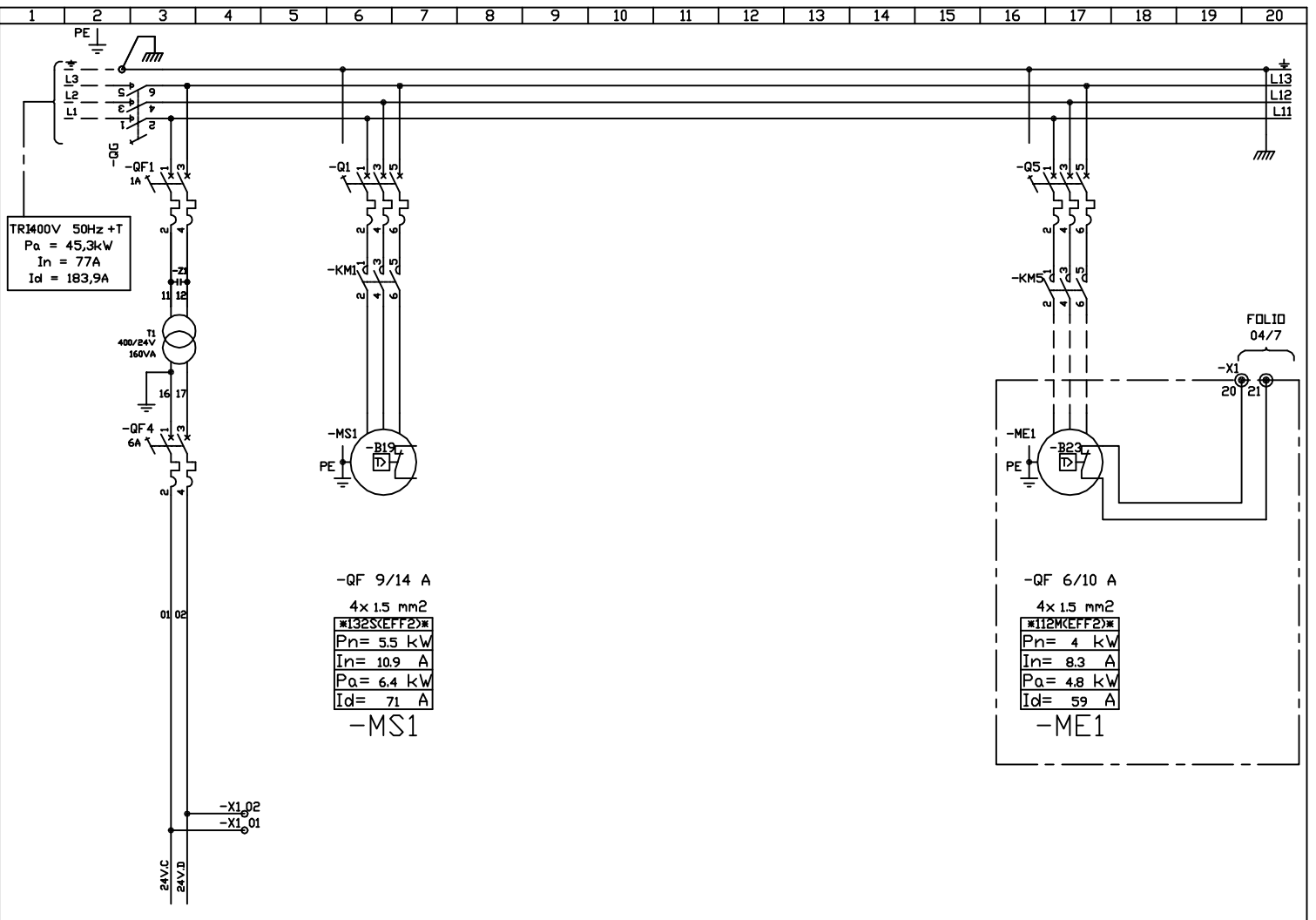

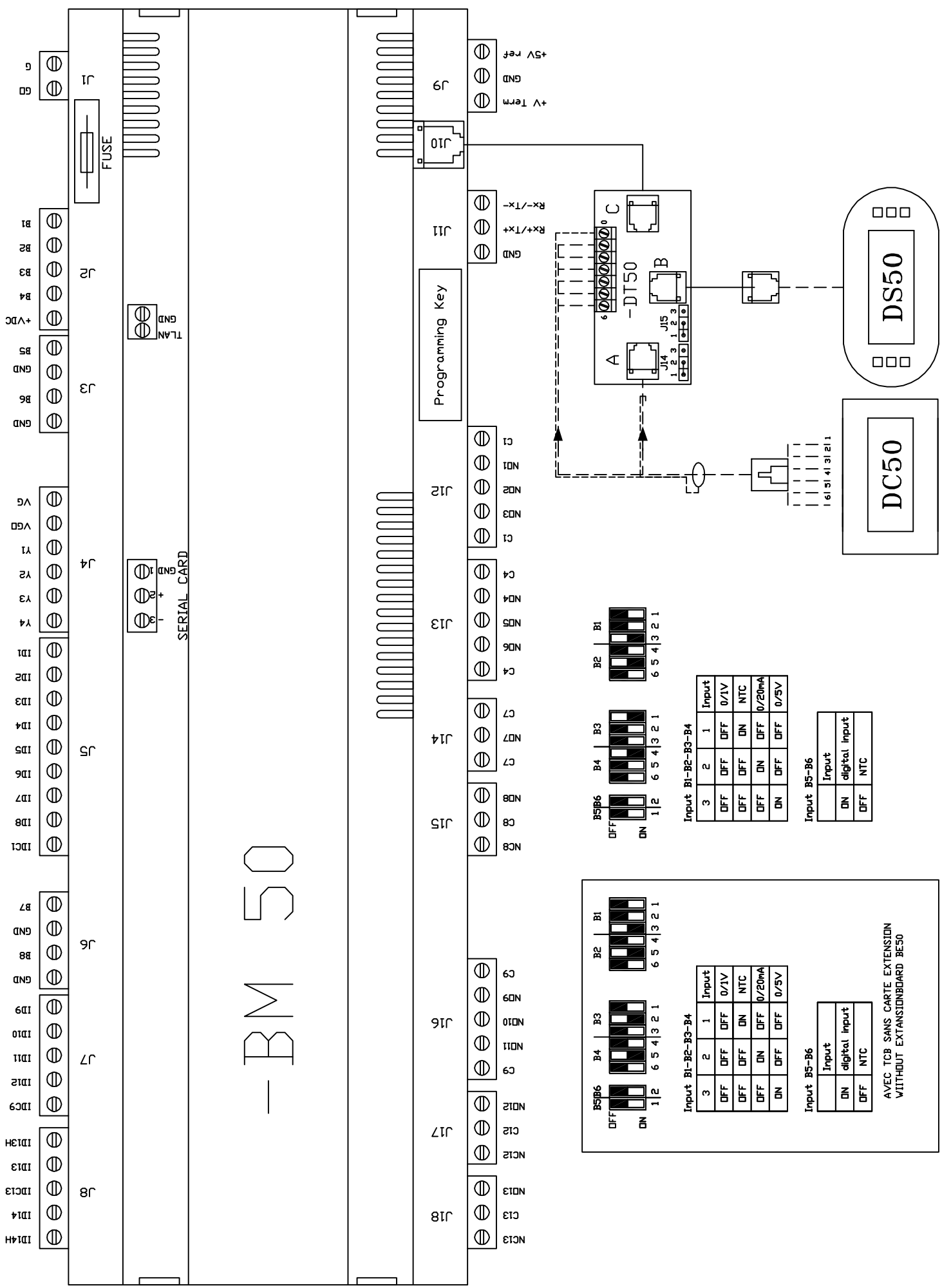
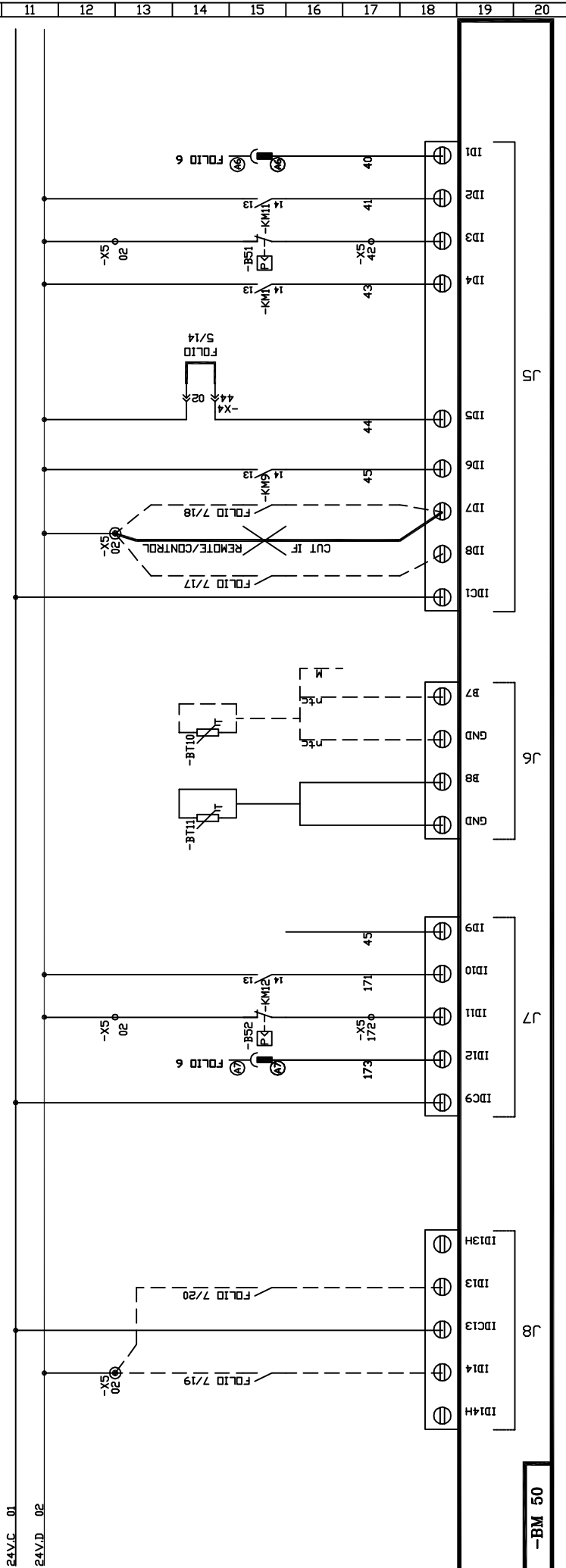
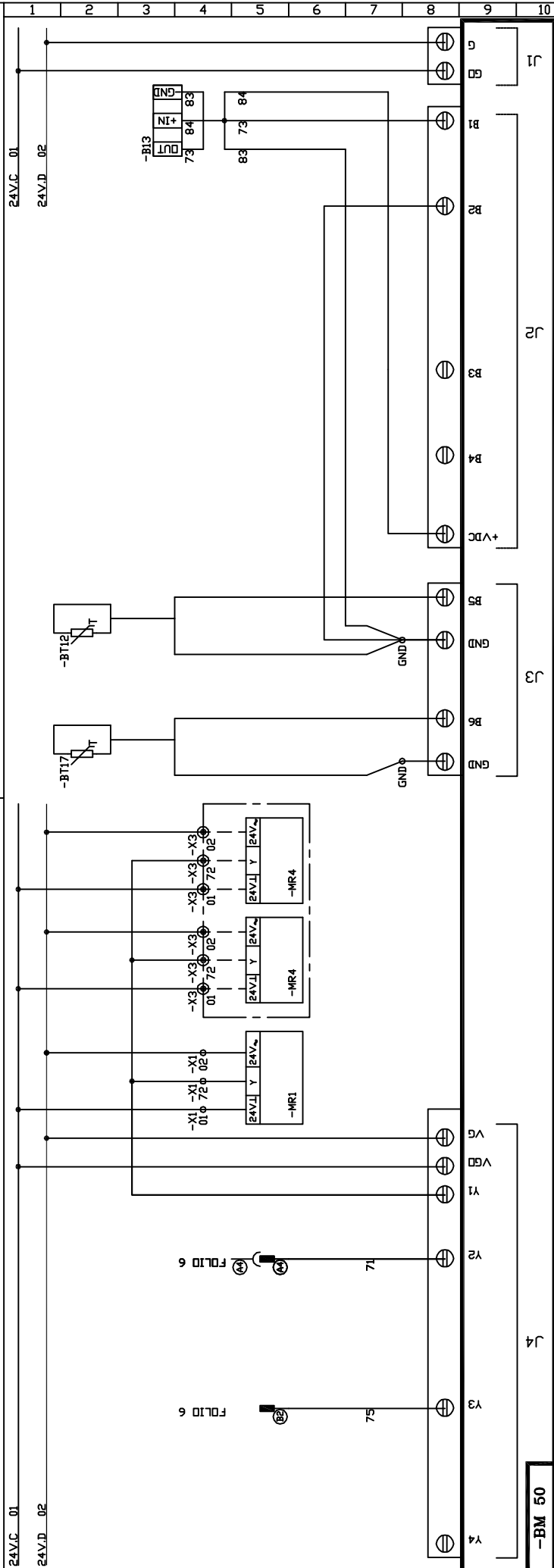

Indice	DATE	NOM	MODIFICATIONS

(1) FCK 085 N
Entrées Automate CLIMATIC 50
CLIMATIC 50 Controller Input

Dessine: CTO
Date: 19.05.05



242354 3/11

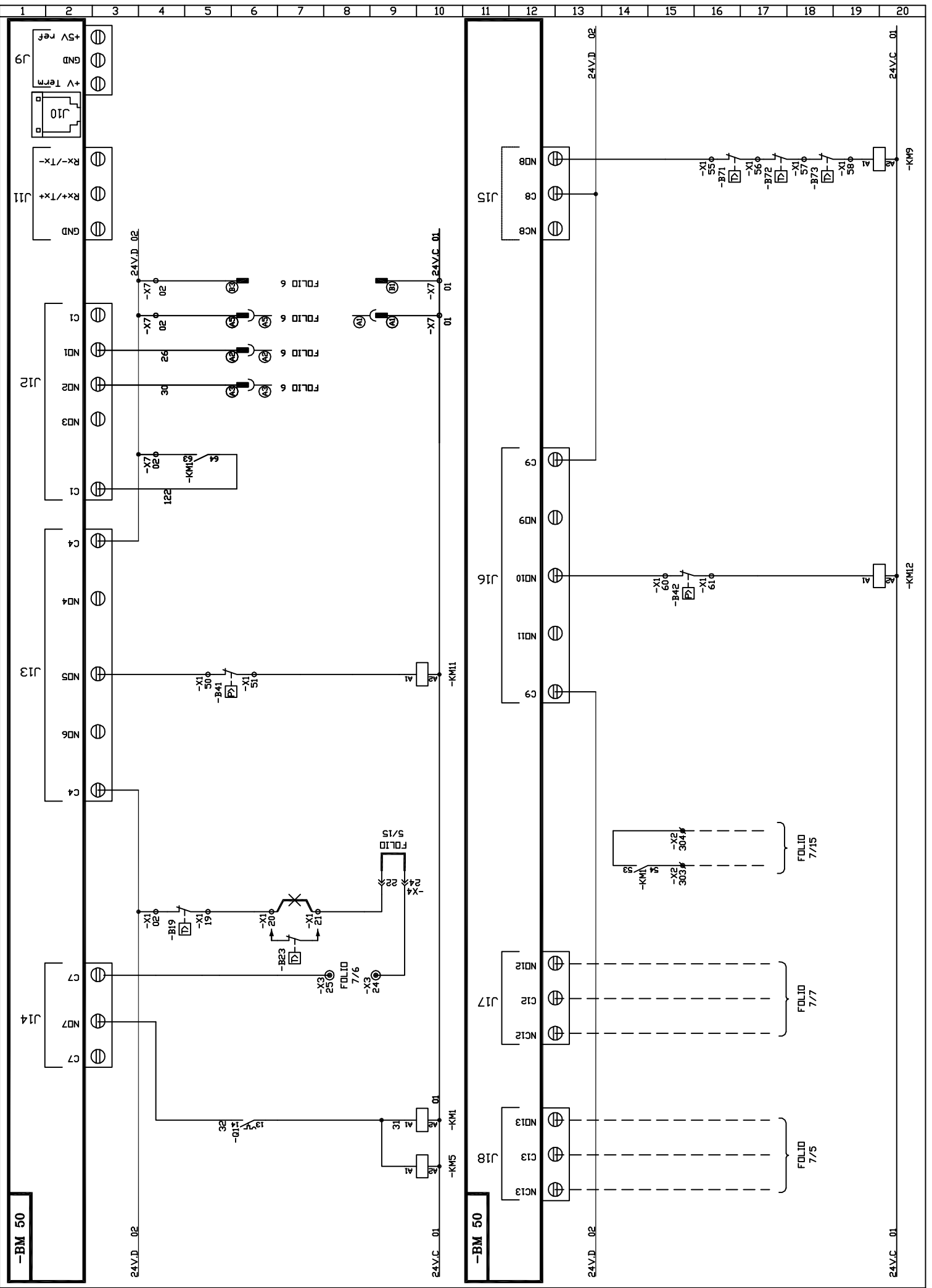

Indice	DATE	NOM	MODIFICATIONS

(1) FCK 085 N
Sorties Automate CLIMATIC 50
Climatic 50 Controller Outputs

Dessine: CTO
Date: 19.05.05



242354 4/11

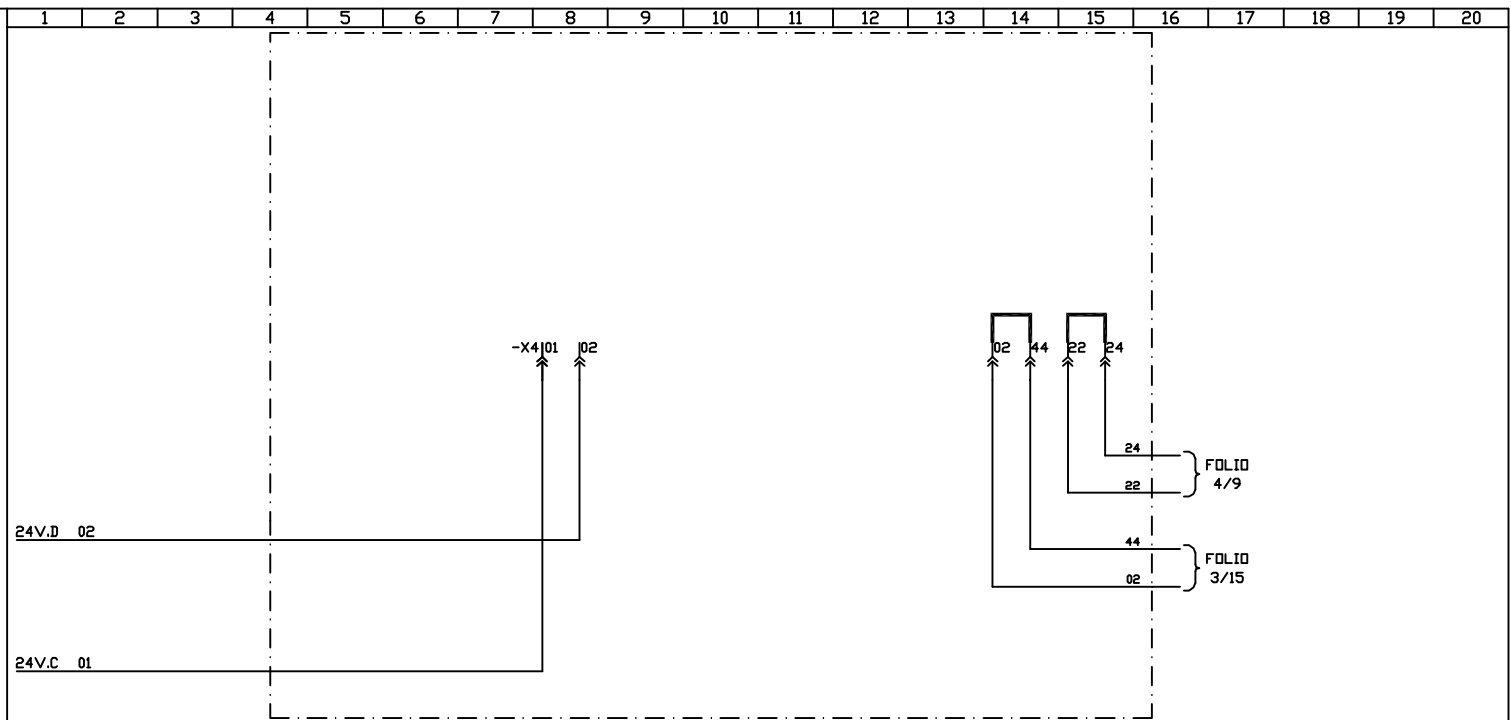

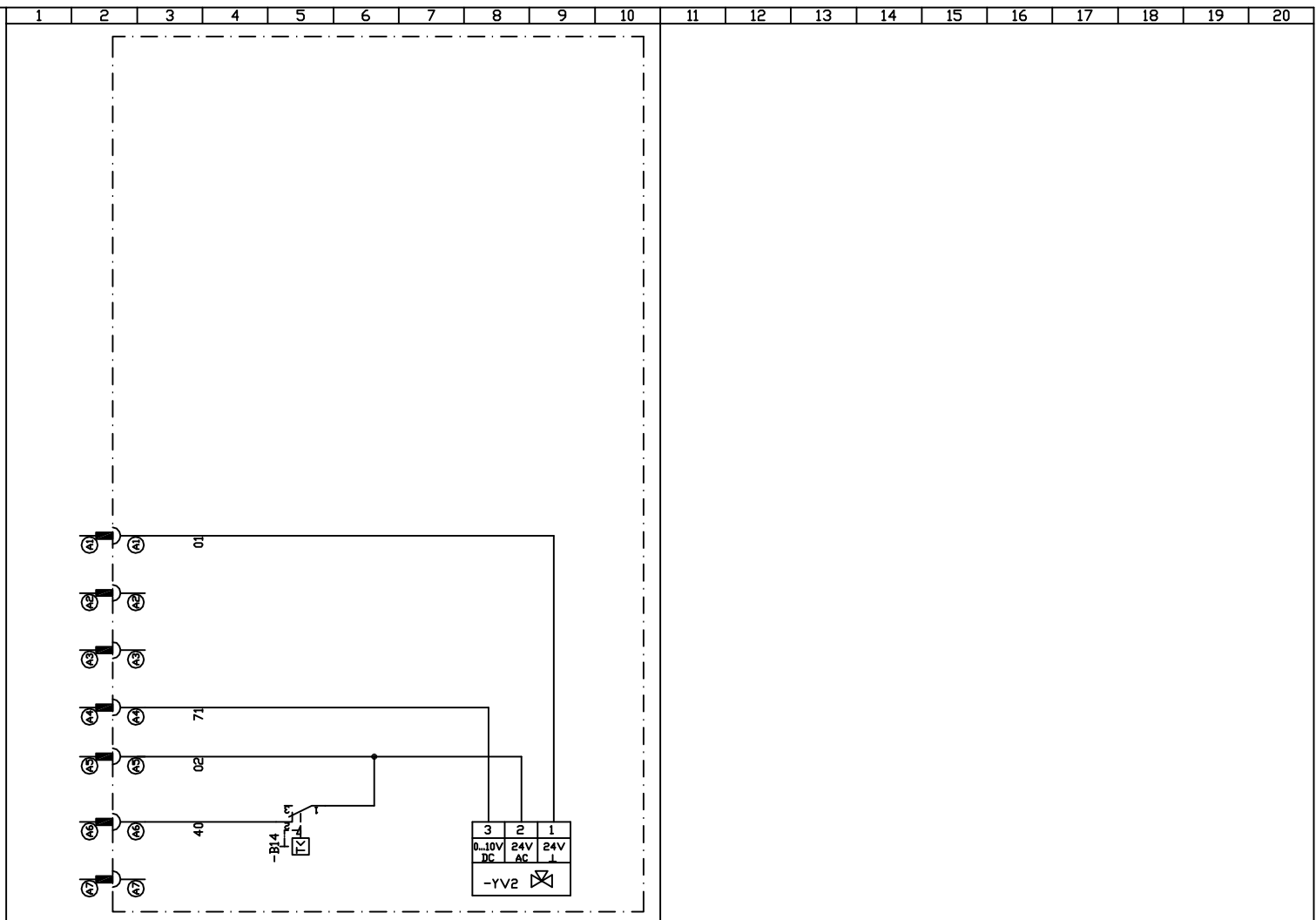

Indice	DATE	NOM	MODIFICATIONS

(1) FCK 085 N
 Kit chauffage
 GAS

Dessine:
 CTO
 Date:
 19.05.05



242354 6/11

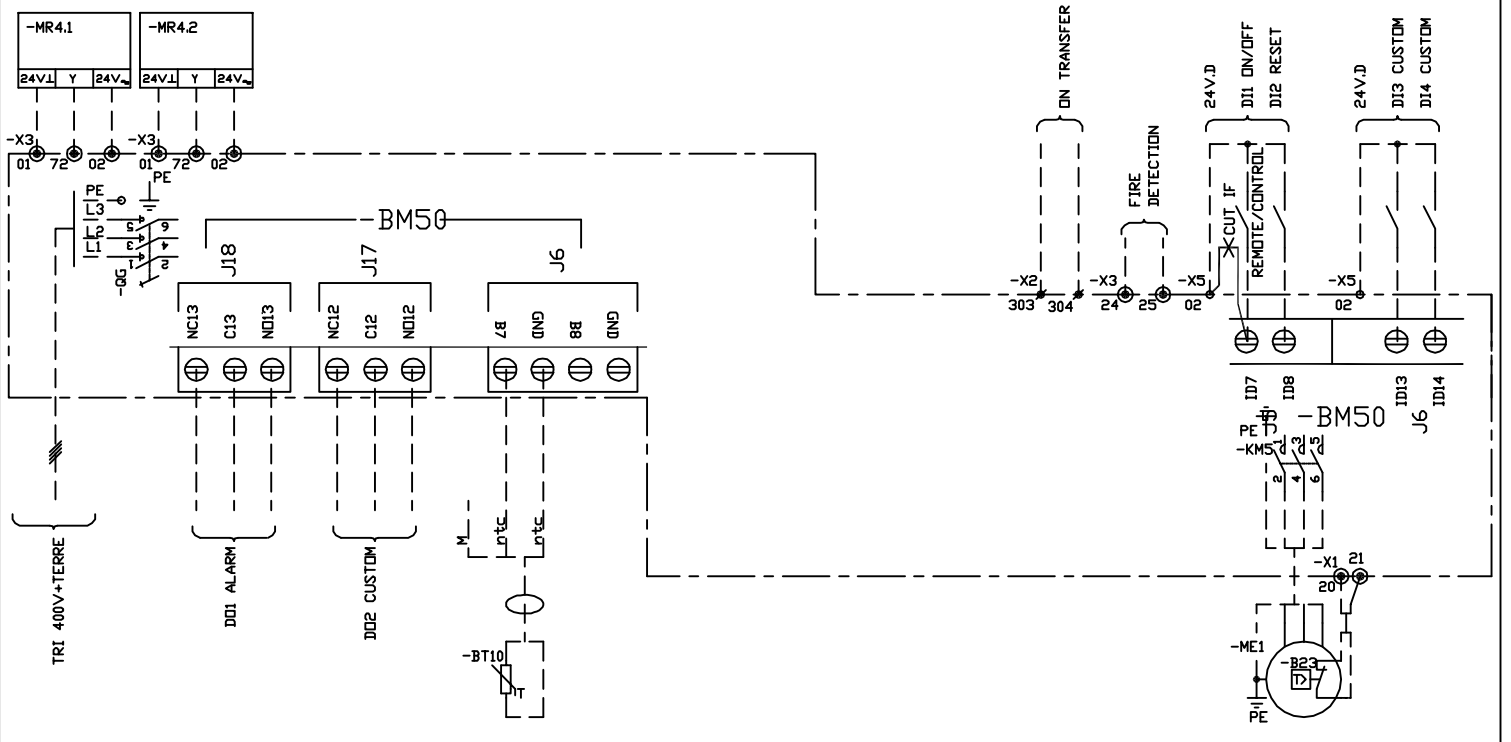
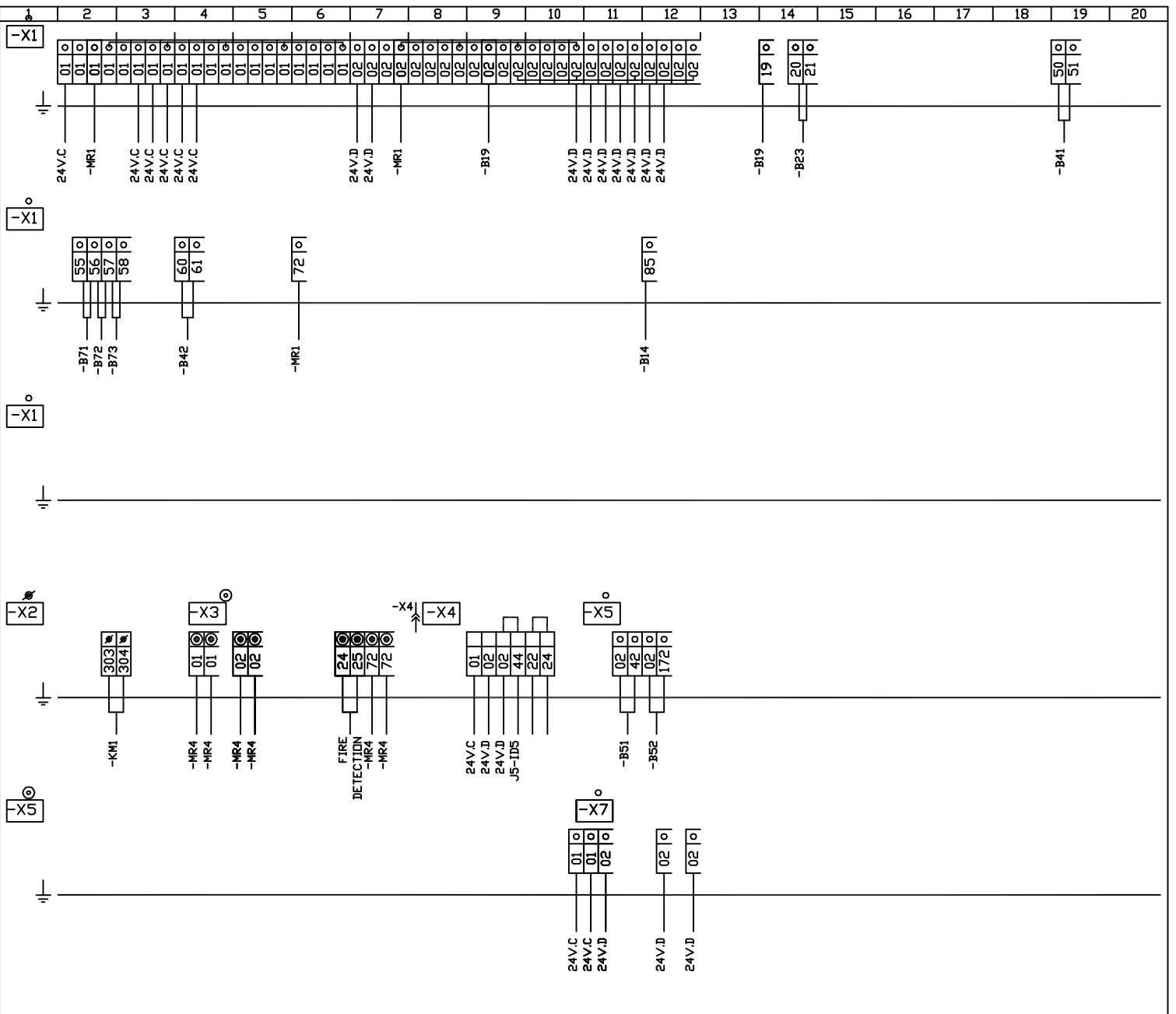

Indice	DATE	NOM	MODIFICATIONS

(1) FCK 085 N
 Borniers \ Raccordement Client
 Terminal Strip \ Customer

Dessine: CTO
 Date: 19.05.05



242354 7/11

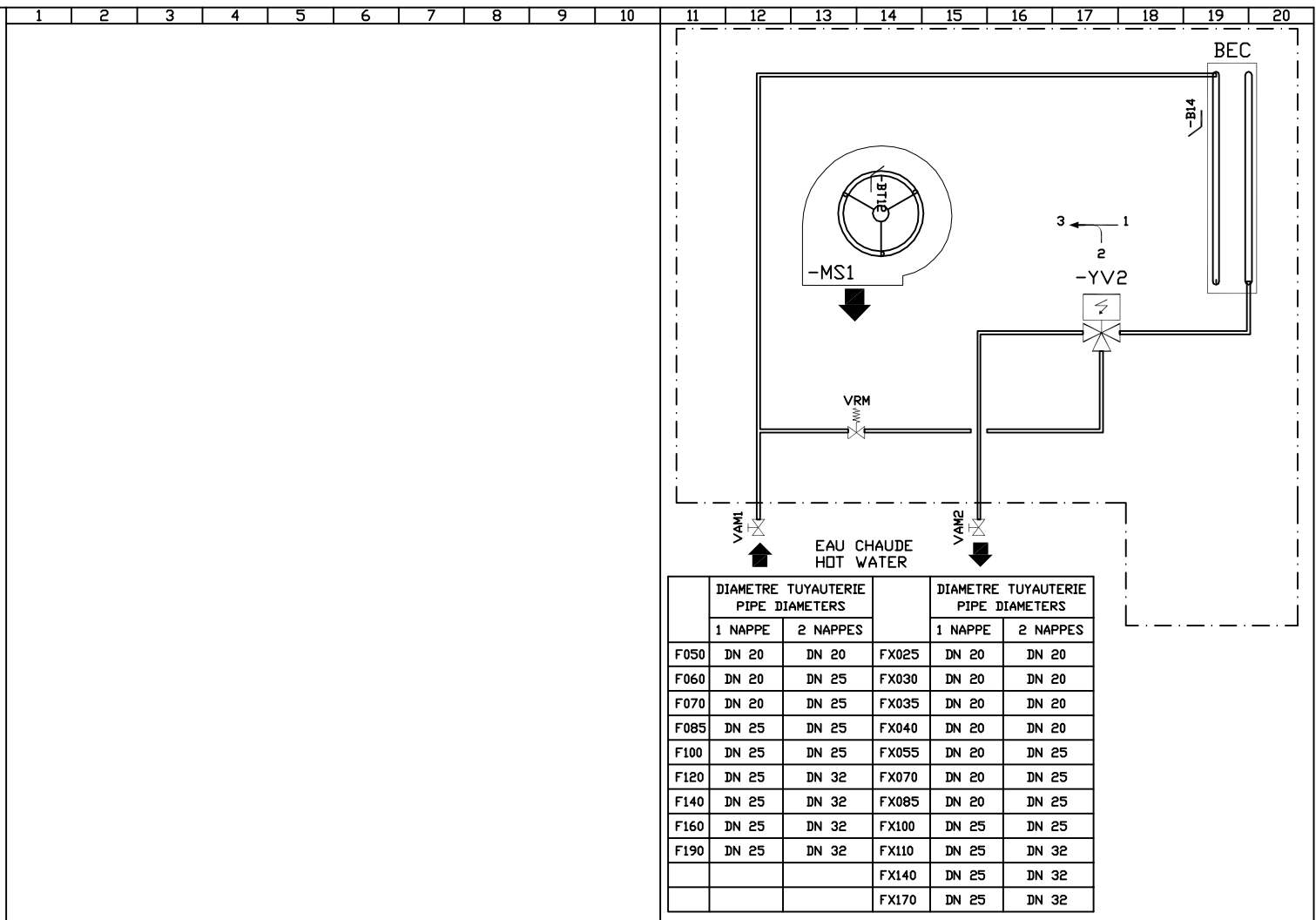

	DIAMETRE TUYAUTERIE PIPE DIAMETERS		DIAMETRE TUYAUTERIE PIPE DIAMETERS	
	1 NAPPE	2 NAPPE	1 NAPPE	2 NAPPE
F050	DN 20	DN 20	FX025	DN 20
F060	DN 20	DN 25	FX030	DN 20
F070	DN 20	DN 25	FX035	DN 20
F085	DN 25	DN 25	FX040	DN 20
F100	DN 25	DN 25	FX055	DN 20
F120	DN 25	DN 32	FX070	DN 20
F140	DN 25	DN 32	FX085	DN 20
F160	DN 25	DN 32	FX100	DN 25
F190	DN 25	DN 32	FX110	DN 25
			FX140	DN 25
			FX170	DN 25

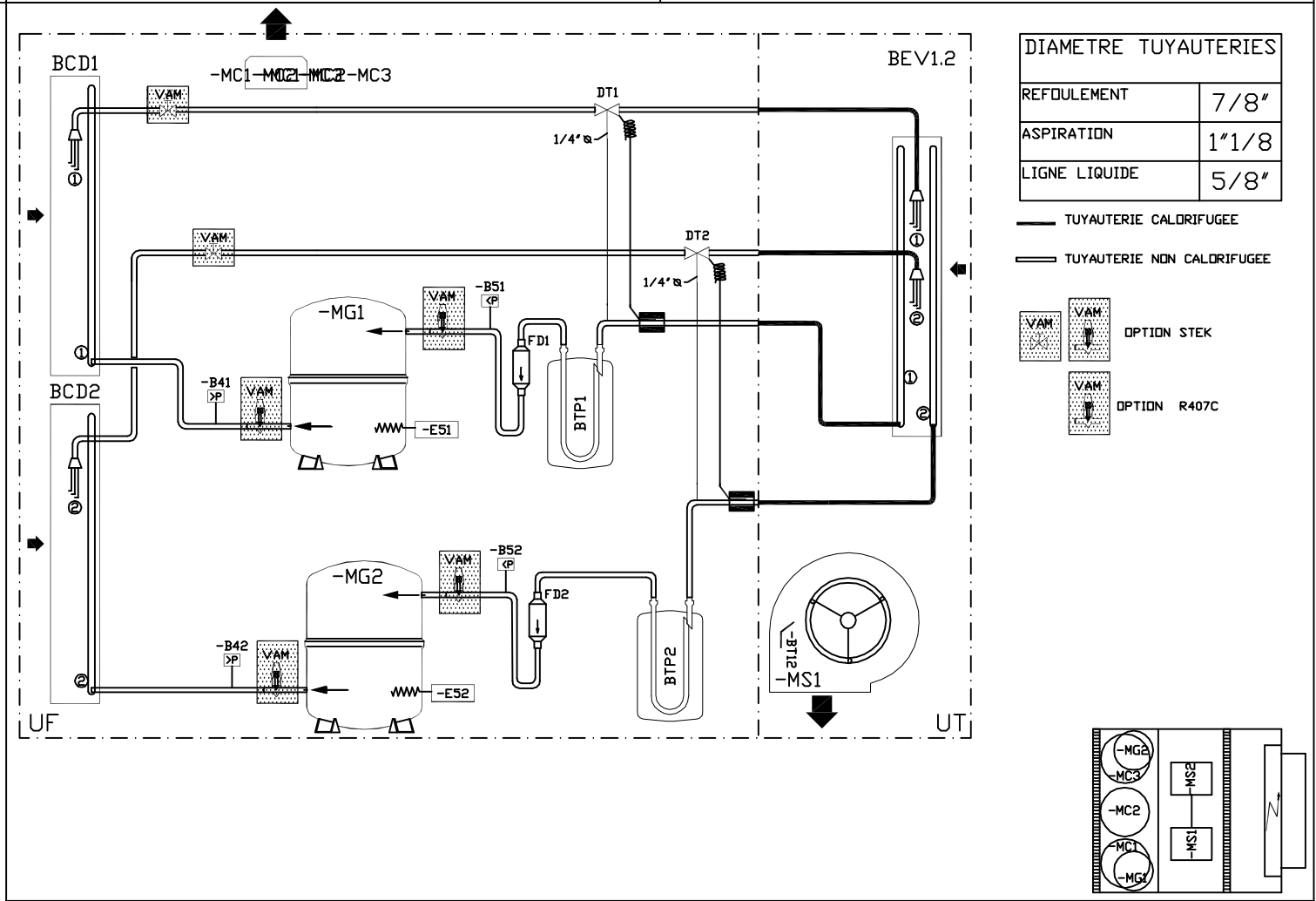

DIAMETRE TUYAUTERIES	
REFOULEMENT	7/8"
ASPIRATION	1"1/8"
LIGNE LIQUIDE	5/8"

- TUYAUTERIE CALDRIFUGEE
- TUYAUTERIE NON CALDRIFUGEE
- OPTION STEK
- OPTION R407C

