

ELEMENTOS OPCIONALES / OPTIONAL ELEMENTS

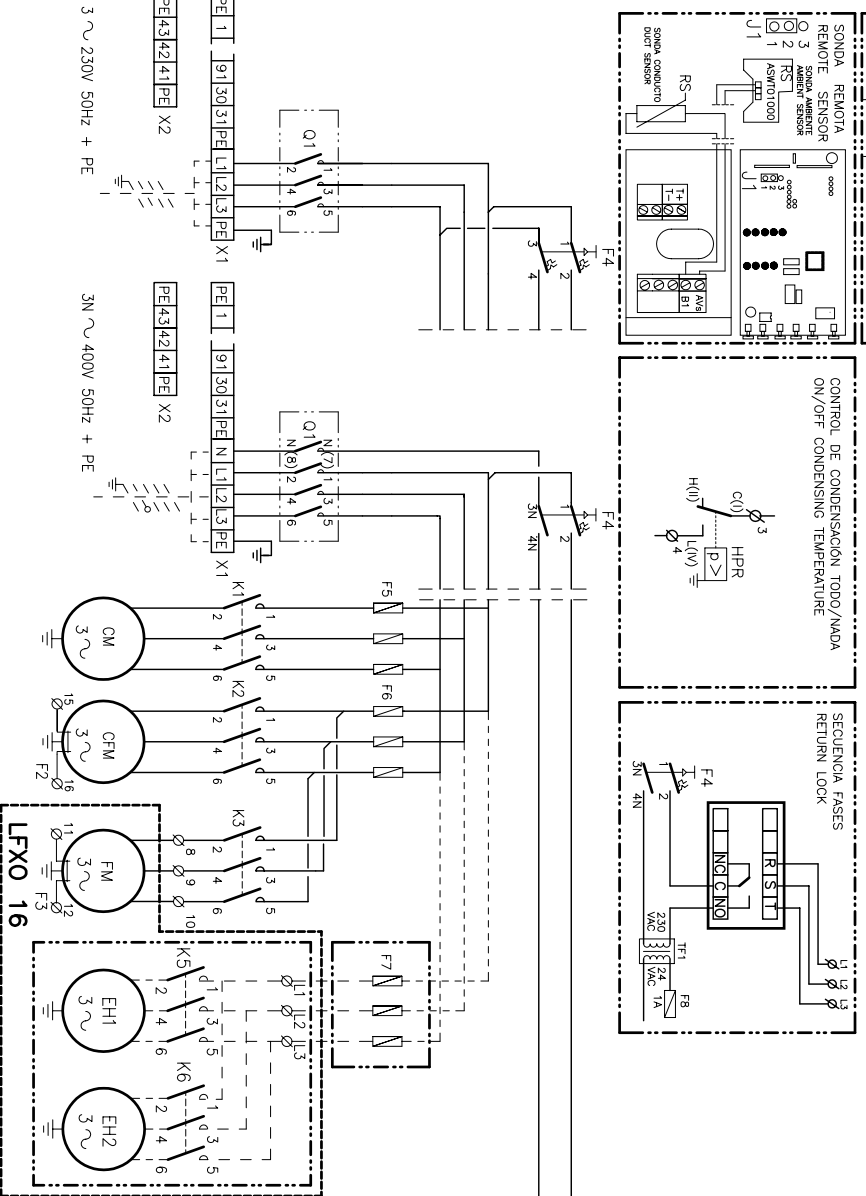

Elemento Opcional  
Optional Element  
A Realizar por el Instalador  
To Wire By the Installer

Fusibles	F5	F6
Fusibles size	3 x 25A	3 x 16A
	3 x 16A	3 x 10A

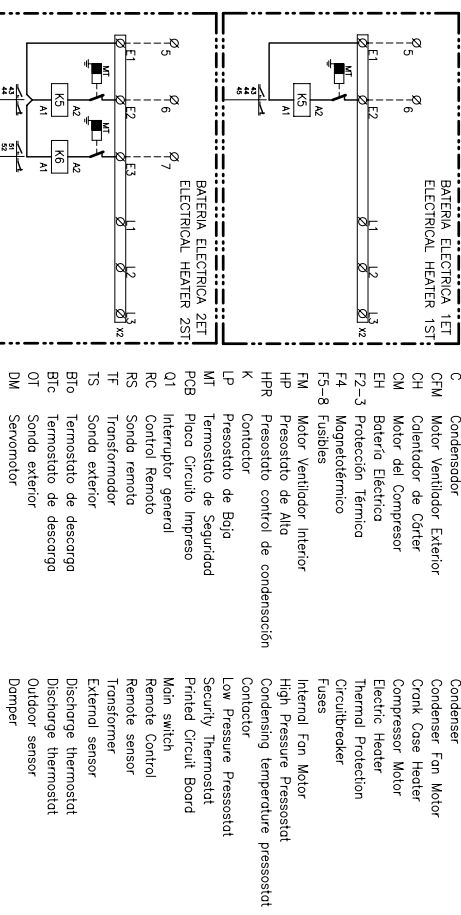
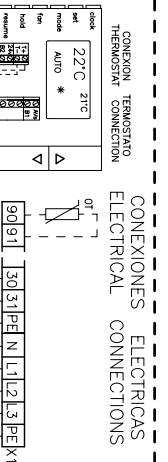
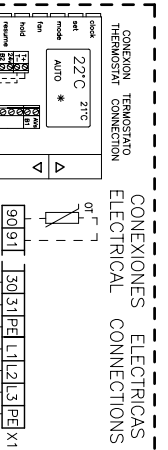
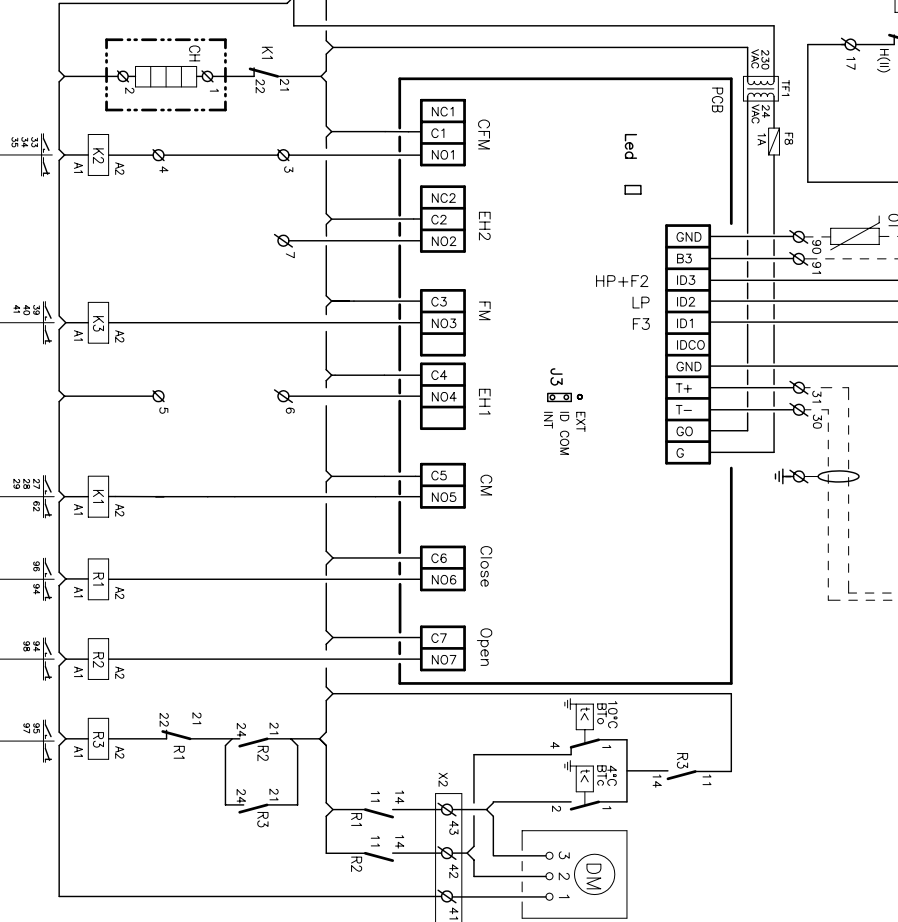
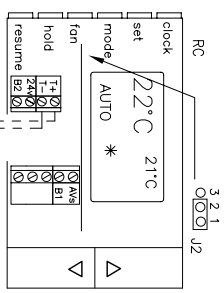

Lemox Refrco S.A. ESQUEMA ELECTRICO ELECTRICAL DIAGRAM

FLCK (LFXO+KFCK) 16

37-33-374-434 288  
3N 400V 50HZ PE  
3 ~ 230V 50Hz + PE