

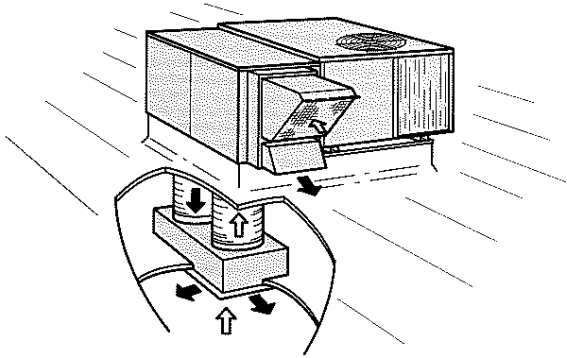

CHP16H-261/CHP16-413, -513 AND -653
PACKAGED UNITS — HEAT PUMPS
 6.6 to 15.7 kW (22 500 to 53 500 Btuh) Cooling Capacity
 5.7 to 15.0 kW (19 600 to 51 400 Btuh) Optional Electric Heat

CHP16
 7.0 to 17.6 kW
 (2 to 5 Ton)
 Bulletin #490036
 October 1994
 Supersedes October 1990



CHP16H Rooftop Installation With Combination Supply and Return Air System

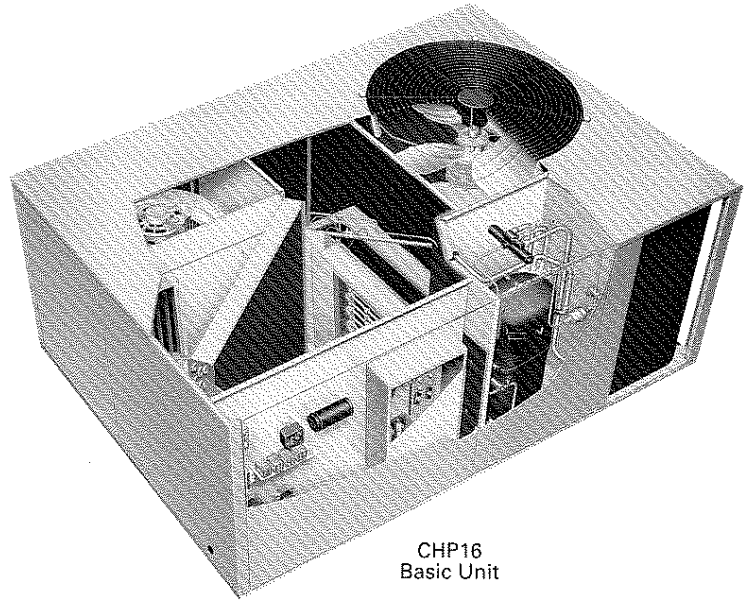

CHP16 Basic Unit

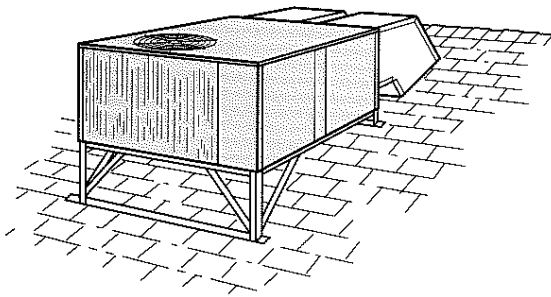

CHP16H Residential Rooftop Installation

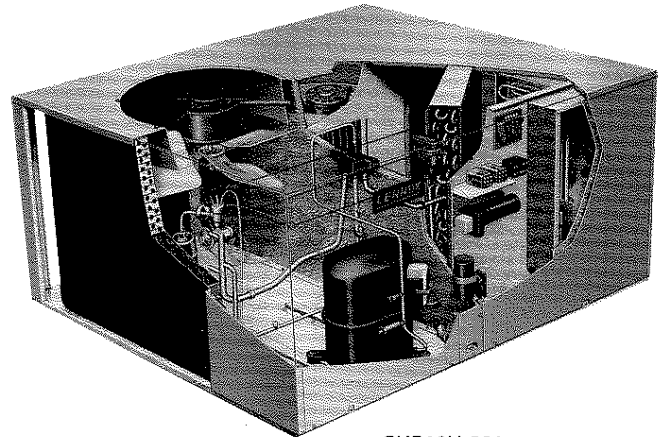

CHP16H-261 Basic Unit

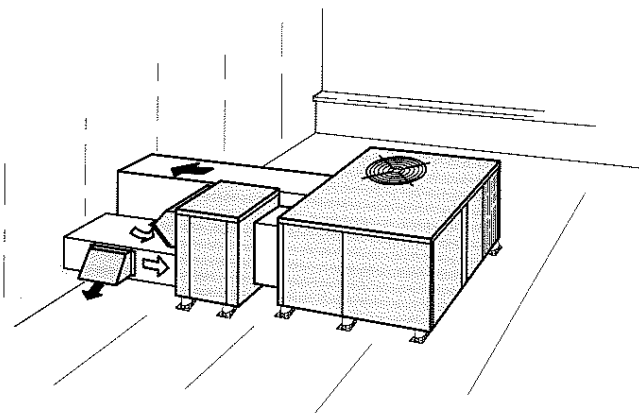

CHP16 Rooftop Installation With Horizontal Economizer

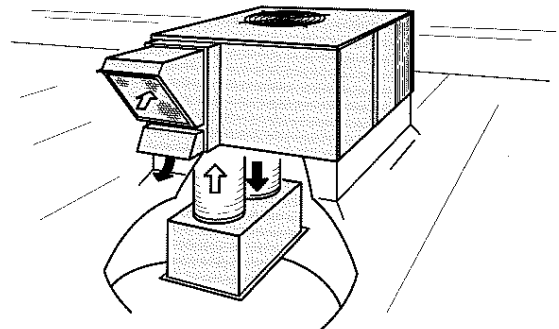

CHP16 Rooftop Installation With Combination Supply and Return Air System

FEATURES

Application — Lennox CHP16/CHP16H single package heat pumps units are designed for outdoor rooftop or ground level installations in residential or light commercial applications. Units are capable of delivering bottom (down-flo) or side (horizontal) handling of supply and return air. CHP16 models are available in three models with three phase voltage. CHP16H-261 model is available with single phase voltage.

The CHP16-413-513-653 models are available with a choice of thermostat and related controls which include; electro-mechanical, W973, T7300 and W7400. In addition a factory installed commercial controls platform consisting of; control system and economizer wiring harness is furnished as standard. The commercial controls platform and related control systems are not available on the CHP16H-261 model.

Optional accessories include; supplemental electric heaters, outdoor coil guards, roof mounting frames, stand-off mounting kit, down-flo or horizontal economizer dampers with modulating or three position damper motor, step-down or flush ceiling supply and return air diffusers, duct enclosure (CHP16H-261 model) and manual outdoor air dampers. See Optional Accessories tables.

Completely Tested — Units have been tested in the Lennox Research Laboratory Environmental Test Rooms which meet American Society of Heating, Refrigeration and Air-Conditioning Engineers (ASHRAE) Standard 37 requirements. The rating test conditions are those included in Air Conditioning and Refrigeration Institute (ARI) Standard 210/240-89 while operating at rated voltage and air volumes. In addition, units have been sound rated in the Lennox reverberant sound test room in accordance with test conditions for Air-Conditioning and Refrigeration Institute (ARI) Standard 270-84. Units and components within are bonded for grounding to meet safety standards for servicing required by Underwriter's Laboratories (U.L.) and the International Electrotechnical Commission (IEC). Blower data is from unit tests conducted in the Lennox Laboratory air test chamber.

Cabinet — Rugged cabinet is constructed of heavy gauge galvanized steel. Cabinet is subject to a five station metal wash process resulting in a perfect bonding surface for the paint finish of powder enamel, electrostatically bonded to the metal. Large removable cabinet panels allow service access. Base section and cabinet panels exposed to conditioned air are lined with thick fiberglass insulation. Supply and return air openings have flanges for ease of duct connection. Control box with factory installed controls is conveniently located for service access. A low voltage terminal strip is furnished and factory installed with CHP16-413, -513 and -653 models. Electrical inlets are furnished for entry into the cabinet. Indoor coil drain pan is constructed of corrosion resistant galvalume and is equipped with a galvanized pipe drain outlet. Lifting brackets are factory installed on CHP16-413, -513 and -653 models.

Refrigeration System — Complete factory sealed refrigeration system consists of compressor, outdoor coil and fan, indoor coil and blower, thermometer well, reversing valve, suction and discharge line service gauge ports and full operating charge of refrigerant. CHP16H-261 and CHP16-413 models have a refrigerant metering / flow control device. Bullet-shaped metering orifice moves to free flow position during reverse refrigerant flow, eliminating check valve. CHP16-513 and -653 models have a check and expansion valve. CHP16-413, -513 and -653 models have factory installed high pressure switch (manual reset) and loss of charge switch.

Compressor — Rugged and reliable compressor is hermetically sealed, suction cooled, overload protected and equipped with internal pressure relief valve. Built-in protection devices assure protection from excessive current and temperature. The entire running gear is spring mounted within the sealed housing. In addition, the compressor is installed in the unit on resilient rubber mounts assuring quiet and vibration free operation. All compressors have an immersible self-regulating type crankcase heater. Heater is temperature actuated to operate only when required and ensures proper lubrication at all times.

Suction Line Accumulator (CHP16-513-653 Models) — Factory installed and piped. Traps and prevents large amounts of liquid refrigerant from flooding directly into the compressor and causing damage on start-ups.

Copper Tube/Enhanced Fin Outdoor and Indoor Coils — Extra large surface area and circuiting of Lennox designed coils provide maximum cooling efficiency, excellent heat transfer and low air resistance. Coils are constructed of precisely spaced ripple-edged aluminum fins fitted to durable copper tubes. Fins are equipped with collars that grip tubing for maximum contact area. Lanced fins provide maximum exposure of fin surface to air stream. Flared shoulder tubing connections and silver soldering provide tight, leakproof joints. Long life copper tubing is easy to field service. Coil is thoroughly factory tested under high pressure to insure leakproof construction. Indoor coils feature rifled copper tubing for superior refrigerant flow resulting in maximum heat transfer.

Defrost Control — A solid state clock timer defrost control provides a defrost cycle, if needed every 30 or 60 or 90 minutes (adjustable) of compressor "on" time at outdoor temperatures below 7°C (45°F). A thermostat mounted on the outdoor coil determines when the defrost cycle is required and also when to terminate a cycle.

Blower — Units are equipped with direct drive centrifugal blower precisely matched to the unit for maximum efficiency and minimum noise level. Blower is statically and dynamically balanced as an assembly before being installed in the unit. Multiple speed permanent split capacitor (PSC) motor is resiliently mounted. A choice of blower speeds is available, see blower performance tables. Change in blower speed is easily accomplished by a simple field change in wiring.

Outdoor Coil Fan — Direct drive fan draws air through the outdoor coil and discharges it vertically, up and away from the building. Fan orifice design and low fan tip speed keeps operating sound level at a minimum. Uniform air movement through the coil results in high refrigerant cooling capacity. Permanently lubricated, inherently protected, PSC motor is totally enclosed for maximum protection from rain, dust and corrosion. All models are equipped with a corrosion resistant polyvinyl chloride (PVC) coated steel wire fan guard.

Commercial Controls Platform (CHP16-413, -513 and -653 Models) — A commercial controls platform is furnished and factory installed on the CHP16-413-513-653 models. This control platform consists of control system and economizer wiring harness with jack plug connections. The wiring harness facilitates installation of the control system and economizer dampers. A choice of several systems are available, see page 4. Not available for CHP16H-261 model.

Air Filters — Cleanable polyurethane filter and filter rack is furnished for field installation in CHP16 models in down-flo applications. For horizontal applications without economizer, filter must be field installed in return air duct. Filters for CHP16H-261 model in basic unit applications must be provided by installer for installation in the return air system exterior to the unit cabinet.

OPTIONAL ACCESSORIES (Must Be Ordered Extra)

Supplemental Electric Heat (Optional) — Electric heaters field install internal to the unit cabinet and are available in several kW sizes, see Electric Heat Data tables. Heaters are factory assembled with controls installed and wired. Low voltage wiring only requires plug-in field connection. Helix wound nichrome heating elements are exposed directly in the air stream resulting in instant heat transfer, low element temperatures and long service life.

ECH16R heating elements are equipped with accurately located individual limit controls with fixed temperature off setting and automatic reset. Elements also have supplemental thermal cutoff safety fuses providing positive protection in case of excessive temperatures. Cutoff fuses are mounted external to the element face plate for quick and easy replacement. Heaters are also equipped with a thermal relay sequencer to bring the elements on and off line, in sequence, with a time delay between each element. Sequencer also initiates and terminates blower operation.

ECH16 heating elements are equipped with accurately located individual limit controls with fixed temperature off setting and automatic reset. Elements also have supplemental secondary limits providing positive protection in case of excessive temperatures. Secondary limits are mounted external to the element face plate for quick and easy replacement. Fuse block is also furnished. ECH16-20 and 25 Kw (3ph) electric heaters are equipped with a thermal relay sequencer to bring the heating elements on and off line, in sequence, with a time delay between each element. Sequencer also initiates and terminates blower operation. Heating control relay(s) is furnished as standard. Heater control box and access cover are constructed of heavy gauge galvanized steel.

Unit Single Point Power Source Sub-Fuse Box (Optional) — Field installs internal to the unit cabinet. Provides sub-fusing to the unit. Used in conjunction with the ECH16 electric heat control box or the ECH16R electric heat single point power source sub-fuse box, for single point power source applications. Fuses are furnished with box. Constructed of galvanized steel with prepunched mounting holes and electrical inlet and outlet holes. Box cover is hinged for easy access. Three boxes are available, shipping weight 2 kg (5 lbs.). See Electric Heat Data tables for usage.

'R' Series Electric Heat Single Point Power Source Sub-Fuse Box (Optional) — Available for use with ECH16R electric heaters. Used in conjunction with ECH16 fuse box for single point power source applications. Field installs internal to the unit cabinet. Fuses are furnished with box. Box is constructed of galvanized steel with prepunched mounting holes and electrical inlet and outlet holes. Box cover is hinged for easy access. Three boxes are available, shipping weight 2 kg (4 lbs.). See Electric Heat Data tables for usage.

Outdoor Thermostat Kit (Optional) — An outdoor thermostat can be used to lock out some of the electric heating elements on ECH16-15 kW (1 ph) optional electric heater. Outdoor thermostat maintains the heating load on the low power input as long as possible before allowing the full power load to come on the line. Thermostat kit LB-29740BA (56A87) and mounting box M-1595 (31461) must be ordered extra.

Air Filters (Optional for CHP16H-261 Model Only) — Filter for basic unit must be provided by the installer in the return air system exterior to the unit cabinet.

OPTIONAL ACCESSORIES (Must Be Ordered Extra)

Low Ambient Kit (Optional for CHP16-513 and -653 Models Only) — Units will operate satisfactorily in the cooling mode down to 7°C (45°F) outdoor air temperature without any additional controls. For cases where operation of the unit in the cooling mode is required at low ambients, a Low Ambient Control Kit LB-57113BM (27J00) can be added in the field, enabling it to operate properly down to -1°C (30°F). Kit must be ordered extra.

Timed-Off Control (Optional) — Timed-off control LB-50709BA (32F21) is available for field installation. Prevents compressor short-cycling and also allows time for suction and discharge pressure to equalize on CHP16H-261 and CHP16-413 models, permitting the compressor to start in an unloaded condition. Automatic reset control provides a time delay between compressor shutoff and start-up.

Outdoor Coil Guards (Optional) — Polyvinyl chloride (PVC) coated steel wire coil guards are available and must be ordered extra. CHP16H-261 model requires 2 per unit, LB-82199CH (47J25). CHP16-413 model requires 2 per unit, LB-82199CF (47J23). CHP16-513-653 models require 3 per unit, LB-82199CG (47J24). Correct number of guards are furnished per order number.

Unit Stand-Off Mounting Kit (Optional) — Field installed kit (38H18) elevates horizontal application units above the mounting surface away from damaging moisture. Includes six high impact polystyrene stand-off mounts. Stand-offs are easily attached to unit and mounting surface. See dimension drawings. Kit must be ordered extra.

RDE16-31 Duct Enclosure (Optional for CHP16H-261 Only) — The duct enclosure mounts to the CHP16H-261 unit and RMF16-31 roof mounting frame. Included with duct enclosure is a unit mounting platform that mounts on top of the roof frame. Heavy gauge steel platform has support rails that elevate unit off the mounting surface. Duct enclosure is completely insulated with thick fiberglass insulation, has a baked-on enamel paint finish and is shipped factory assembled. Supply and return air openings are located in the bottom of the enclosure. Minimum outdoor air damper allows a fixed amount (0-25%) of outdoor air into the system. A 25mm (one-inch) thick frame type disposable filter is furnished in the enclosure. Filter rack will accept up to 51mm (two-inch) thick filter. Access panel allows easy access to air filter. Also furnished with the enclosure is a wiring harness for use with optional economizer. Provisions have been made in the duct enclosure for easy field installation of the optional REMD16 economizer dampers.

RMF16 Roof Mounting Frame (Optional) — Roof mounting frame mates to the unit and provides a weather sealed rooftop installation. Shipped knocked down for ease of shipping and handling, it is easily field assembled. A wood nailer strip is secured to the frame sides to facilitate flashing. Design is approved by the U.S. National Roofing Contractor's Association. RMF16-31 is used with CHP16H-261 unit. RMF16-41 may be used with all sizes of CHP16 units with slight overhang on the -513 and -653 models. RMF16-65 frame exactly matches the CHP16-513 and -653 models.

Roof Curb Power Entry Kit (Optional for CHP16-413, -513 and -653 Models Only) — Field installed kit is available for power entry to the unit through the roof mounting frame. Kit contains 1.0m (40 inch) length of armored conduit and necessary installing hardware. Knockouts in end of roof mounting frame are provided for ease of installation. See dimension drawing. Two kits are required, one for low voltage and one for high voltage. Kits must be ordered extra. Three conduit sizes are available. Order Kit No. (18H70) — 13mm (1/2 inch), (18H71) — 25mm (1 inch), (18H72) — 38mm (1-1/2 inch).

REMD16 Economizer (Optional) — Economizer field installs directly in CHP16 unit cabinets. See dimension drawings. Economizer consists of: cabinet constructed of heavy gauge steel with a baked-on enamel paint finish, outdoor air intake hood, combination outdoor air and recirculated air dampers with pressure operated gravity exhaust air damper. Formed damper blades rotate smoothly in nylon bearings and are gasketed for a tight seal. The economizer dampers and controls are shipped factory assembled, adjusted and cycled and only require plug-in connection. The positioning of the outdoor and recirculated air dampers is accomplished by a 24 volt three position spring return damper motor with adjustable minimum position switch and controlled by the room thermostat, electronic discharge air sensor and solid-state adjustable outdoor air enthalpy control. The enthalpy control allows 0 to 100% outdoor air to be used for "free cooling" when outdoor temperature and humidity are acceptable. Indoor filter is not furnished. REMD16 utilizes existing filter furnished with CHP16-413, -513, -653 units and return air filter furnished with RDE16 Duct Enclosure for CHP16H-261. Filter rack will accept up to 51mm (2 in.) thick filter. See Air Resistance table, page 15, for resistance data of 51mm (2 in.) pleated non-woven cotton fabric or 51mm (2 in.) thick fiberglass filter media. Removable exhaust air hood allows access to filter. Outdoor air intake hood is field installed. A cleanable aluminum mesh frame filter in the outdoor air hood provides extra air filtering and bird screen protection.

REMD16M Economizer (Optional) — The REMD16M economizer damper section is identical to the REMD16 model except it is equipped with a fully modulating spring return damper motor. See Optional Accessories table.

EMDH16 Horizontal Economizer (Optional for CHP16-413, -513 and -653 Models Only) — The horizontal economizer section is shipped factory assembled, adjusted and cycled. Field installs on the unit and only requires plug-in connection. The economizer section consists of: heavy gauge steel cabinet with baked-on enamel paint finish, fully insulated with thick fiberglass insulation and recirculated air and outdoor air dampers. Formed damper blades rotate smoothly in nylon bearings and are gasketed for tight seal. The positioning of the outdoor and recirculated air dampers is accomplished by a 24 volt three position spring return damper motor with adjustable minimum position switch and controlled by the room thermostat, electronic discharge air sensor and solid-state adjustable outdoor air enthalpy control. The enthalpy controls allows 0 to 100% outdoor air to be used for "free cooling" when outdoor humidity and temperature are acceptable. A 25mm (one-inch) thick disposable fiberglass filter is furnished. Filter rack will accept up to 51mm (two-inch) thick filter. Removable panel allows easy access to filter. A cleanable aluminum mesh filter in the outdoor air hood provides extra air filtering and bird screen protection.

EMD16M Economizer (Optional) — The EMD16M horizontal economizer damper section is identical to the EMD16 model except it is equipped with a fully modulating spring return damper motor. See Optional Accessories table.

GEDH16-65 Gravity Exhaust Dampers (Optional) — Available for use with EMDH16M horizontal economizer assembly. Pressure operated assembly field installs in the return air duct adjacent to the economizer assembly. Exhaust dampers also have bird screen.

Differential Enthalpy Control (Optional) — A solid-state return air enthalpy sensor is available to be used in conjunction with the outdoor air enthalpy control to determine which air has the lowest enthalpy. The air with the lowest enthalpy will be selected. Return air enthalpy sensor (54G44) field installs in the REMD16M or EMDH16M economizer damper section and must be ordered extra.

Lifting Lug Kit (Optional for CHP16H-261 Model Only) — Field installed kit LB-62125DB (44H92) facilitates handling and rigging of units. Reusable heavy gauge steel lifting lugs (4) are easily and quickly secured to units by means of a sliding steel pin. See dimension drawing for locations. Must be ordered extra.

OAD3-46/65 Manual Minimum Fresh Air Damper (Optional for CHP16H-261 Model Only) — Fresh air damper field installs in the return air duct adjacent to the unit cabinet. Equipped with manually operated damper which will allow a fixed amount of outdoor air into the system.

OAD16 Manual Minimum Fresh Air Damper (Optional for CHP16-413, -513 and -653 Models Only) — Built-in damper assembly is furnished in cabinet panel that field interchanges with existing blower access panel. Manually operated sliding damper allows entry of a fixed amount (0-25%) of outdoor air into the system. See dimension drawing. An outdoor air hood with cleanable filter media is also provided.

FD9-65 Combination Ceiling Supply and Return Diffuser Assembly (Optional) — Flush mount diffuser installs almost flush with the ceiling level and discharges conditioned air out through fixed blade louvers on all four sides. Fixed blade louvers insure that air flow will be evenly distributed. Return air enters through large center grille. Assembly also includes insulated diffuser box with connection collars for round duct connection, support hanger eyelets at the top corners for secure installation and molded fiberglass interior transition to insure low static and even air flow on all four sides. Transition is sealed internally to prevent recirculation. Diffuser assembly is completely factory assembled. Diffuser readily adapts to T-bar ceiling grids and plaster ceilings. Must be ordered extra, see Optional Accessories table.

RTD9-65 Combination Ceiling Supply and Return Diffuser (Optional) — RTD9-65 step-down mount diffuser extends slightly below ceiling level when installed and discharges conditioned air out through grilles on all four sides. Aluminum grilles are fitted with double deflection louvers for precise directional control of air flow. Return air enters through the large center grille. Assembly also includes insulated diffuser box with connection collars for round duct connection, hanging rings for suspending and molded fiberglass interior transition to insure low static and even air flow on all four sides. Transition is sealed internally to prevent recirculation. Diffuser assembly is completely factory assembled. Diffuser readily adapts to T-bar ceiling grids and plaster ceilings. Must be ordered extra. See Optional Accessory table.

SRT16 and SRT16H Supply and Return Transitions (Optional) — Transitions field install in the roof mounting frame and provide segregated and simple duct connections to supply and return diffuser. Completely insulated galvanized steel transitions have collars for round duct connection. Round duct from the transitions to the diffuser is not furnished and must be provided by the installer. Transitions are completely factory assembled and easily field install in the roof mounting frame with minimum costs and labor requirement. Must be ordered extra. See Optional Accessories table.

CONTROL SYSTEM OPTIONS (CHP16-413,-513,-653 Models Only)

Electro-Mechanical Thermostat and Control System (Optional) —

The thermostat and related controls of this system must be ordered extra. Two stage heat and two stage cool thermostat (13F06) with dual temperature selector levers. Uses subbase (13F17) with manual system switch (Off-Heat-Auto-Cool) and fan switch (Auto-On) or emergency heat subbase and relay kit (49G09) with manual system switch (Off-Emergency Heat-Heat-Auto-Cool), fan switch (Auto-On) and red emergency heat indicator LED. Also available is a non-switching subbase (13F16). SP11 Remote Status Panel (12F83) or SSP11 Remote Switching Status Panel (12F84) is available for observing and controlling unit operation from the conditioned area. A SSP11 Relay Kit (41G39) is required for switching functions of the Switching Status Panel. Kit must be ordered extra. For nite operation the following are available. Single stage heating thermostat (13F12) and non-switching subbase (13F16). For applications without the economizer a Nite Kit (39G74), containing a plug-in relay, is required to override the operation of day thermostat. Two time clocks are available for the system. Automatic 7 day time clock (43G98) programs a weekly schedule. Any day or days can be omitted. Day and nite periods are distinctly marked. When the settings have been made the clock will turn the system on and off. Spaced in 2 hour increments and equipped with battery back-up in case of power outage. 24 hour nite setback time clock (43G99) automatically programs the system to keep conditioned area at a more conservative temperature level (nite setback thermostat setting) during a period of vacancy. Spaced in 15 minute increments and equipped with battery back-up in case of power outage. Also available is a Warm Up Kit (39G77) which holds the economizer outdoor air dampers closed during nite heat operation and morning warm up. See Flow Chart on Page 5.

W973 Control System (Optional)—

Control system must be ordered extra. Logic Panel (39G76) controls the operation of the economizer dampers and the stages of cooling and heating in response to a signal from the thermostat. To maintain stable temperatures the logic panel balances the conditioned space thermostat demand against the system output. System output is measured by a discharge sensor (furnished with the logic panel) located in the discharge air duct of the unit. The combined demand and output signals from the sensor determines economizer damper position and number of cooling or heating stages energized. The logic panel field installs in the unit or in a remote panel located within the conditioned space. W973 Plug-In Relay (furnished with the logic panel) is required to adapt the control system to the unit. Two thermostats are available for the system. Dual set point room thermostat (25C52) or transmitter (25C51) with a choice of remote sensors. Both have separate heating-cooling locking set points concealed under the cover and do not have indicating thermometer. The room thermostat has integral sensor and installs in the conditioned space. The transmitter installs outside the conditioned space with a Room Temperature Sensor (58C92) in the conditioned area or a Return Air Temperature Sensor (27C40) in the return air duct of the unit. Thermostat and transmitter are furnished with a wiring wallplate. Also available is a switching subbase (58C94) with system selector switch (Cool-Auto-Heat-Emergency Heat) and fan switch (On-Auto-Off). SP11 Remote Status Panel (12F83) or SSP11 Remote Switching Status Panel (12F84) is available for observing and controlling unit operation from the conditioned area. Two time clocks are available for the system. Automatic 7 day time clock (43G98) programs a weekly schedule. Any day or days can be omitted. Day and nite periods are distinctly marked. When the settings have been made the clock will turn the system on and off. Spaced in 2 hour increments and equipped with battery back-up. 24 hour nite setback time clock (43G99) automatically programs the system to keep the conditioned area at a more conservative temperature level (nite set back thermostat setting) during a period of vacancy. Spaced in 15 minute increments and equipped with battery back-up. Also available is a Warm Up Kit (39G77) which holds economizer outdoor air dampers closed during nite heat operation and warm up. See Flow Chart on page 5.

W7400 Control System (Optional) —

Control system must be ordered extra. Control Module (74G11) controls the operation of the economizer dampers and the stages of heating and cooling. Controlling input signals are setpoint, space temperature sensor and time-of-day scheduling from the thermostat. The control module balances the space temperature signal against the number of stages operating for system output. System output is measured and updated by monitoring the actual space temperature deviation from set point, and the rate of change of the space temperature. The control module field installs in

the unit or in a remote panel located within the conditioned area. Two thermostats are available for the system. A room thermostat (43G96) with integral sensor that installs in the conditioned space or a remote thermostat (43G97) that installs outside the conditioned space with a Room Temperature Sensor (58C92) in the conditioned area or a Return Air Temperature Sensor (27C40) in the return air duct of the unit. Both thermostats are equipped with touch sensitive keyboard, automatic switching from heat to cool, no anticipator, zero droop, indicator lites, hour/day programming, override capabilities, time readout, stage status indicators, battery back-up and wiring wallplate. W7400 Plug-In Relay (furnished with the control module) provides separate set points for the economizer dampers and DX cooling. SP11 Remote Status Panel (12F83) is available for checking unit operation within the conditioned area. See Flow Chart on page 6.

T7300 Thermostat and Control System (Optional) —

The thermostat and related controls of this system must be ordered extra. T7300 programmable thermostat (81G59) has internal or optional remote temperature sensing, touch sensitive keyboard, automatic switching from heat to cool, °C or °F temperature readout, no anticipator, droop/no droop selection, indicator LED's, hour/day programming, override capabilities, time readout, stage status indicators, operational mode readout and battery back-up. T7300 thermostat has a choice of subbases. Switching subbase (81G60) has selectable output staging up to two heat and two cool, manual system switch (Heat-Off-Auto-Cool), fan switch (Auto-On) and two status LED's for monitoring various equipment operation. Switching subbase (13H76) features selectable output staging up to three heat and two cool, indicator LED's, manual system switch (Auto-Cool-Off-Heat-Emergency Heat) and fan switch (Auto-On). Both subbases also features an auxiliary relay output which controls economizer operation during occupied and unoccupied periods. Also available is a Room Temperature Sensor (58C92) or Room Temperature Sensor with 3-hour override and setpoint adjustment (86G67) for installation in the conditioned area and a Return Air Temperature Sensor (27C40) for installation in the return air duct of the unit. SP11 Status Panel (12F83) is available for checking unit operation from within the conditioned area. See Flow Chart on page 6.

SP11 Remote Status Panel (Optional) — The operation of the unit can be checked on the Remote Status Panel (12F83) located within the conditioned area. Signal lights on the panel indicate "Cool Mode," "Heat Mode," "Compressor 1," "Compressor 2," "No Heat" and "Filter." The Cool Mode signal light is green when lit and indicates cooling operation. Heat Mode light is green and reflects heating operation. Compressor 1 light is green when operating and will turn red if there is an operational malfunction. Compressor 2 (not used) light is not required and should be disregarded. The No Heat and Filter lights will show red and indicate a requirement for service. Additional controls are required for use with the Status Panel must be specified when ordering. Filter Switch Kit (97C85) is used with the Filter light. Operation of No Heat light with electric heat requires a Current Sensing Relay (29F79). Status Panel Readout Relay Kit (14F92) is required to interface status panel with unit operation.

SSP11 Remote Switching Status Panel (Optional) — The operation of the unit can be controlled and observed on the Switching Status Panel (12F84) conveniently located within the conditioned area. Signal lights on the panel indicate "Cool Mode," "Heat Mode," "Compressor 1," "Compressor 2," (not used) "No Heat" and "Filter." The Cool Mode signal light is green when lit and indicates economizer damper operation or DX cooling operation for units without the economizer. Heat Mode light is green and reflects heating operation. Compressor 1 light is green when operating and will turn red if there is an operational malfunction. Compressor 2 light is not required and should be disregarded. The No Heat and Filter lights will show red and indicates a requirement for service. Additionally, panel is equipped with a system selector switch (Off - Heat - Auto - Cool - Emergency Heat), fan switch (Auto - On) and after hours timer. Fan switch provides a choice of intermittent (Auto) or continuous (On) blower operation. Manually operated after hours timer (0 to 12 hours) overrides night setback controls providing normal operation for time period set. A momentary push button switch is used to initiate the timer period. The following field installed controls are required for use with the status panel and must be ordered extra. Filter Switch Kit (97C85) is required for operation of the filter light. Operation of No Heat light with electric heat requires a Current Sensing Relay (29F79). Status Panel Readout Relay Kit (14F92) is required to interface status panel with unit operation.

TEMPERATURE CONTROL SELECTION FLOWCHARTS

OPTIONAL ELECTRO-MECHANICAL THERMOSTAT CONTROL SYSTEM

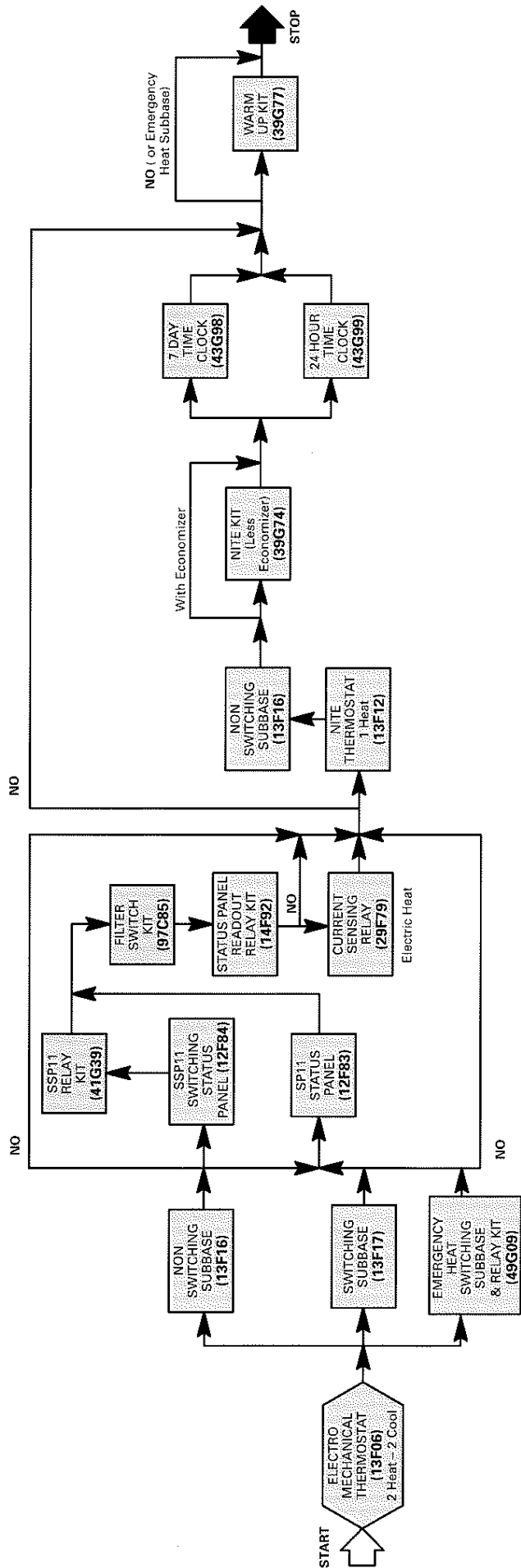

OPTIONAL W973 CONTROL SYSTEM

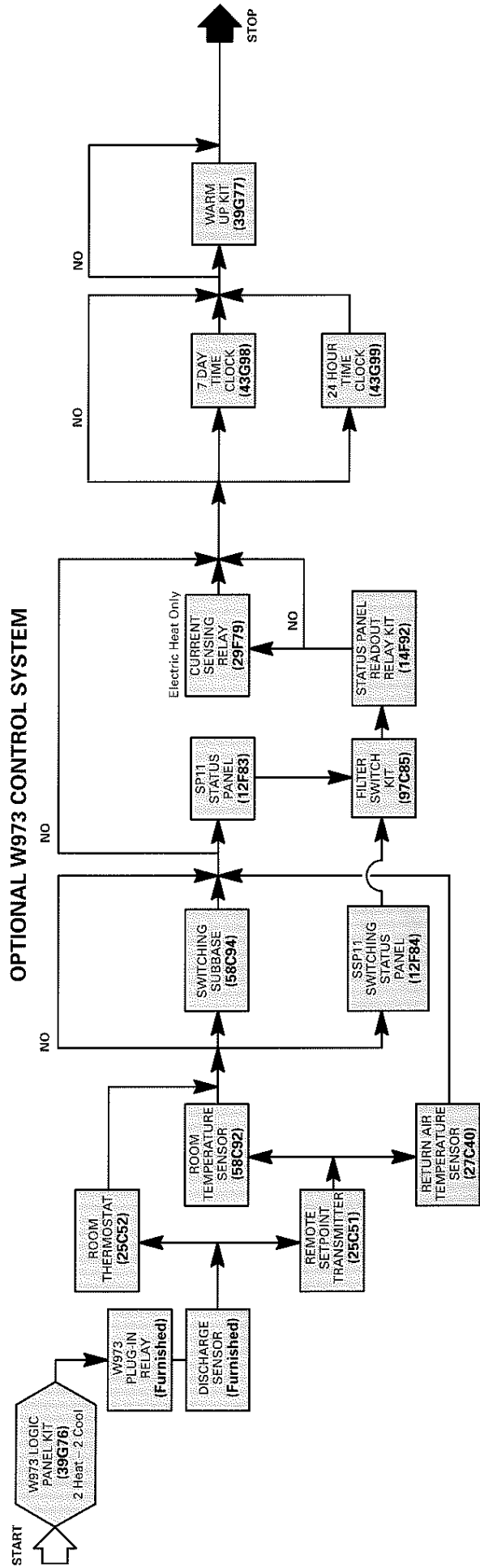

TEMPERATURE CONTROL SELECTION FLOWCHARTS

OPTIONAL W7400 CONTROL SYSTEM

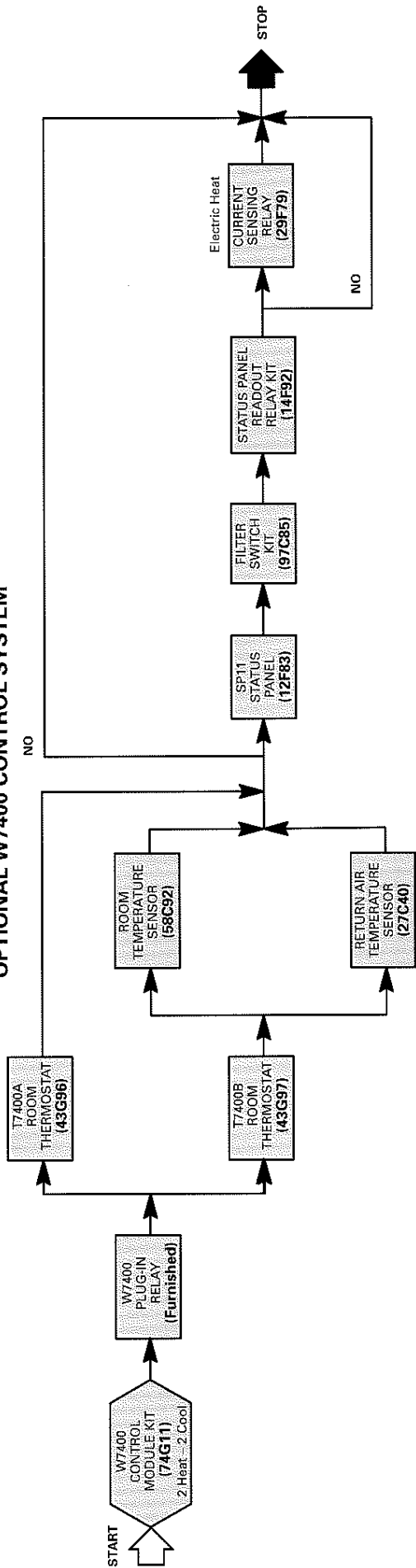

OPTIONAL T7300 CONTROL SYSTEM

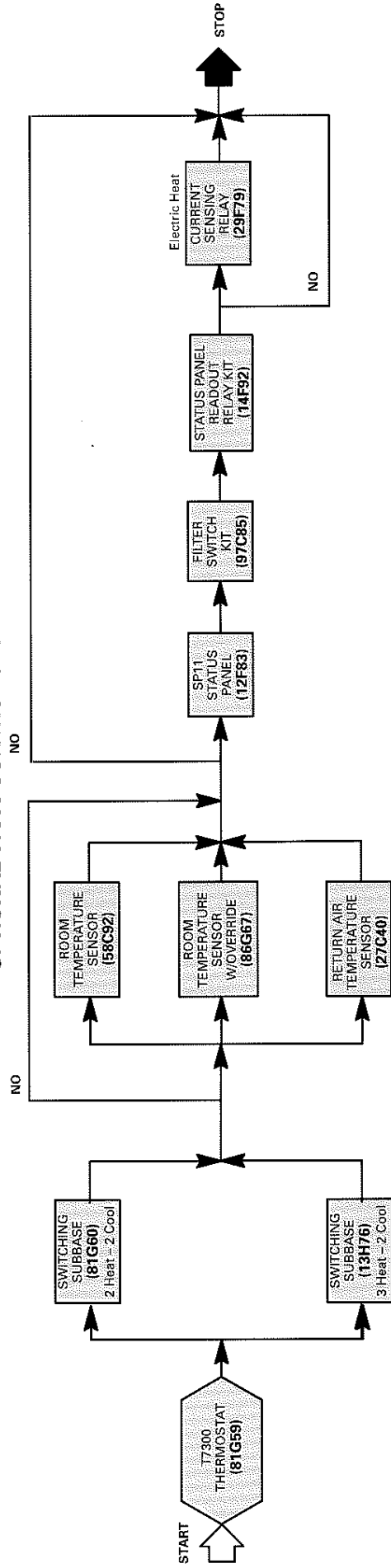

SPECIFICATIONS — CHP16H-261 AND CHP16-413

Unit Model Number		CHP16H-261	CHP16-413
*Cooling Rating	Total cooling capacity — kW (Btuh)	6.6 (22 500)	9.8 (33 300)
	Total power input — kW	2.22	3.28
	Coefficient of Performance — Output/Input	2.9	3.0
	Energy Efficiency Ratio — Btuh/Watt	10.1	10.2
*High Temperature Heating Ratings	Heating Capacity — kW (Btuh)	5.7 (19 600)	9.5 (32 400)
	Total Power Input — kW	1.8	2.8
	Coefficient of Performance — Output/Input	3.1	3.4
*Low Temperature Heating Ratings	Heating Capacity — kW (Btuh)	3.0 (10 400)	5.1 (17 500)
	Total Power Input — kW	1.5	2.3
	Coefficient of Performance — Output/Input	2.0	2.2
★Sound rating number (bels)		7.8	7.8
Refrigerant HCFC-22 charge furnished — kg (ozs.)		2.3 (82)	3.0 (107)
Indoor Blower	Blower wheel nominal diameter x width — mm (inches)	229 x 178 (9 x 7)	254 x 178 (10 x 7)
	Motor output — W (hp)	250 (1/3)	373 (1/2)
Indoor Coil	Net face area — m ² (ft. ²)	0.30 (3.2)	0.38 (4.1)
	Tube outside diameter — mm (inches) — number of rows	9.5 (3/8) — 3	9.5 (3/8) — 3
	Fins per m (fins per inch)	591 (15)	591 (15)
Outdoor Coil	Net face area — m ² (ft. ²)	Outer coil	0.63 (6.8)
		Inner coil	0.77 (8.3)
	Tube outside diameter — mm (inches) — number of rows	9.5 (3/8) — 2	9.5 (3/8) — 2
	Fins per m (fins per inch)	787 (20)	787 (20)
Outdoor Coil Fan	Diameter — mm (inches) — number of blades	457 (18) — 4	508 (20) — 4
	Air volume — L/s (cfm)	745 (1580)	875 (1850)
	Motor output — W (hp)	124 (1/6)	149 (1/5)
	Motor input — W	150	185
Condensate drain size — male pipe thread — mm (inches)		19.1 (3/4)	
†Number and size of filters — mm (inches)		----	(1) 406 x 635 x 25 (16 x 25 x 1)
Net weight of basic unit — kg (lbs.)		137 (303)	167 (368)
Shipping weight of basic unit — kg (lbs.) (1 Package)		167 (368)	196 (432)

★Sound rating number rated at test conditions for Air Conditioning and Refrigeration Institute (ARI) Standard 270.

*The rating test conditions are those included in Air Conditioning and Refrigeration Institute (ARI) Standard 210/240 while operating at rated voltage and air volumes.

Cooling Ratings: 35°C (95°F) outdoor air temperature, 26.7°C (80°F) dry bulb and 19.4°C (67°F) wet bulb entering indoor air.

High Temperature Heating Ratings: 8°C (47°F) db/6°C (43°F) wb outdoor air temperature and 21°C (70°F) entering indoor air.

Low Temperature Heating Ratings: -8°C (17°F) db/-9°C (15°F) wb outdoor air temperature and 21°C (70°F) entering indoor air.

†Filters for CHP16H-261 basic unit are not furnished and must be provided by installer.

OPTIONAL ACCESSORIES — CHP16H-261 AND CHP16-413 (Must Be Ordered Extra)

Unit Model Number		CHP16H-261	CHP16-413
Duct Enclosure — Net Weight — kg (lbs.)		RDE16-31 — 43 (94) (93G44)	----
Number and size of fiberglass filter — mm (inches)		(1) 508 x 508 x 25 (20 x 20 x 1)	----
Roof Mounting Frame — Net Weight — kg (lbs.)		RMF16-31 — 36 (80) (30H79)	RMF16-41 — 34 (75) (73H79)
†Economizer Dampers with Gravity Exhaust	Model Number	3 Position Net Weight — kg (lbs.)	REMD16-41 — 22 (48) (58H73)
		Modulating Net Weight — kg (lbs.)	REMD16M-41 — 22 (48) (58H72)
	Number and size of filters — mm (inches)	Indoor	●(1) 406 x 635 x 25 (16 x 25 x 1) (polyurethane)
		Outdoor	(1) 349 x 635 x 25 (13-3/4 x 25 x 1) (aluminum mesh)
Horizontal Economizer Dampers	Model Number	3 Position Net Weight — kg (lbs.)	EMDH16-41 — 50 (110) (14H97)
		Modulating Net Weight — kg (lbs.)	EMDH16M-41 — 50 (110) (23H03)
	Number and size of filters — mm (inches)	Indoor	(1) 508 x 635 x 25 (20 x 25 x 1) (fiberglass)
		Outdoor	(1) 203 x 610 x 25 (8 x 24 x 1) (aluminum mesh)
Gravity Exhaust Dampers — Net Weight — kg (lbs.) — (Net Face Area)		----	GEDH16-65 — 2 (4) (23H06) Use with EMDH16
Outdoor Coil Guards		47J25	47J23
Roof Curb Power Entry Kit (conduit size) — mm (inches)		(18H70) 13 (1/2) (18H71) 25 (1) (18H72) 38 (1-1/2)	----
Lifting Lug Kit		44H92	----
Differential Enthalpy Control		54G44	
Ceiling Supply and Return Air Diffusers Net Weight kg (lbs.)	Step-Down	RTD9-65 — 30 (67) (27G87)	
	Flush	FD9-65 — 17 (37) (27G86)	
	Transition	SRTH16-65 — 8 (17) (15H03)	SRT16-65 — 9 (20) (15H02)
Outdoor Air Dampers (Manual) — Net Weight — kg (lbs.)		OAD3-46/65 — 3 (7) (23591)	OAD16-41 — 5 (12) (15H00)
Number and size of filters — mm (inches)		----	(1) 127 x 432 x 25 (5 x 17 x 1)
Unit Stand-Off Mounting Kit — Net Weight — kg (lbs.)		LB-62742CA (38H18) contains six stand-offs	
Timed-Off Control		LB-50709BA (32F21)	

●Indoor filter is not furnished with economizer. REMD16 Utilizes filter furnished with CHP16 unit.

†When economizer is used with CHP16H-261, a two stage cooling thermostat is required.

SPECIFICATIONS — CHP16-513-653

Unit Model Number		CHP16-513	CHP16-653	
*Cooling Rating	Total cooling capacity — kW (Btuh)	12.6 (43 200)	15.7 (53 500)	
	Total power input — kW	4.23	5.06	
	Coefficient of Performance — Output/Input	3.0	3.1	
	Energy Efficiency Ratio — Btuh/Watt	10.2	10.6	
*High Temperature Heating Ratings	Heating Capacity — kW (Btuh)	12.5 (42 600)	15.0 (51 400)	
	Total Power Input — kW	3.4	4.4	
	Coefficient of Performance — Output/Input	3.7	3.4	
*Low Temperature Heating Ratings	Heating Capacity — kW (Btuh)	6.8 (23 300)	8.8 (30 000)	
	Total Power Input — kW	2.7	3.4	
	Coefficient of Performance — Output/Input	2.5	2.6	
★Sound rating number (bels)		8.0	8.0	
Refrigerant HCFC-22 charge furnished — kg (ozs.)		4.3 (152)	4.2 (148)	
Indoor Blower	Blower wheel nominal diameter x width — mm (inches)	254 x 203 (10 x 8)	305 x 203 (12 x 8)	
	Motor output — W (hp)	373 (1/2)	373 (1/2)	
Indoor Coil	Net face area — m ² (ft. ²)	0.54 (5.8)	0.54 (5.8)	
	Tube outside diameter — mm (inches) — number of rows	9.5 (3/8) — 3	9.5 (3/8) — 3	
	Fins per m (fins per inch)	591 (15)	591 (15)	
Outdoor Coil	Net face area — m ² (ft. ²)	Outer coil	1.33 (14.3)	1.33 (14.3)
		Inner coil	0.92 (9.9)	1.28 (13.8)
	Tube outside diameter — mm (inches) — number of rows	9.5 (3/8) — 1.7	9.5 (3/8) — 2	
	Fins per m (fins per inch)	787 (20)	787 (20)	
Outdoor Coil Fan	Diameter — mm (inches) — number of blades	610 (24) — 4	610 (24) — 4	
	Air volume — L/s (cfm)	1415 (3000)	1415 (3000)	
	Motor output — W (hp)	187 (1/4)	187 (1/4)	
	Motor input — W	285	285	
Condensate drain size — male pipe thread — mm (inches)		19.1 (3/4)		
Number and size of filters — mm (inches)		(1) 508 x 635 x 25 (20 x 25 x 1)		
Net weight of basic unit — kg (lbs.) (1 Package)		213 (470)	236 (521)	
Shipping weight of basic unit — kg (lbs.) (1 Package)		251 (553)	274 (604)	

★Sound rating number rated at test conditions for Air Conditioning and Refrigeration Institute (ARI) Standard 270.
 *The rating test conditions are those included in Air Conditioning and Refrigeration Institute (ARI) Standard 210/240 while operating at rated voltage and air volumes.
Cooling Ratings: 35°C (95°F) outdoor air temperature, 26.7°C (80°F) dry bulb and 19.4°C (67°F) wet bulb entering indoor air.
High Temperature Heating Ratings: 8°C (47°F) db/6°C (43°F) wb outdoor air temperature and 21°C (70°F) entering indoor air.
Low Temperature Heating Ratings: -8°C (17°F) db/-9°C (15°F) wb outdoor air temperature and 21°C (70°F) entering indoor air.
 †Filters for CHP16H-261 basic unit are not furnished and must be provided by installer.

OPTIONAL ACCESSORIES — CHP16-513-653 (Must Be Ordered Extra)

Unit Model Number		CHP16-513	CHP16-653
Roof Mounting Frame — Net Weight — kg (lbs.)		RMF16-41 — 34 (75) (73H79) or RMF16-65 — 39 (86) (73H81)	
Economizer Dampers with Gravity Exhaust	Model Number	3 Position Net Weight — kg (lbs.)	REMD16-65 — 30 (66) (58H75)
		Modulating Net Weight — kg (lbs.)	REMD16M-65 — 30 (66) (58H74)
	Number and size of filters — mm (inches)	Indoor	(1) 508 x 635 x 25 (20 x 25 x 1) (polyurethane)
		Outdoor	(1) 451 x 635 x 25 (17-3/4 x 25 x 1) (aluminum mesh)
Horizontal Economizer Dampers	Model Number	3 Position Net Weight — kg (lbs.)	EMDH16-65 — 59 (130) (14H98)
		Modulating Net Weight — kg (lbs.)	EMDH16M-65 — 59 (130) (23H02)
	Number and size of filters — mm (inches)	Indoor	(2) 356 x 635 x 25 (14 x 25 x 1) (fiberglass)
		Outdoor	(1) 203 x 711 x 25 (8 x 28 x 1) (aluminum mesh)
Gravity Exhaust Damper		GEDH16-65 — 2 (4) (23H06) use with EMDH16	
Differential Enthalpy Control		54G44	
Outdoor Coil Guards		47J24	
Roof Curb Power Entry Kit (conduit size) — mm (inches)		18H70 13 (1/2) 18H71 25 (1) 18H72 38 (1-1/2)	
Ceiling Supply and Return Air Diffusers Net Weight kg (lbs.)	Step-Down	RTD9-65 — 30 (67) (27G87)	
	Flush	FD9-65 — 17 (37) (27G86)	
	Transition	SRT16-65 — 9 (20) (15H02)	
Outdoor Air Dampers — Net Weight — kg (lbs.)		OAD16-65 — 5 (12) (15H01)	
Number & size of filters — mm (inches)		(1) 208 x 432 x 25 (8 x 17 x 1)	
Unit Stand-Off Mounting Kit — Net Weight — kg (lbs.)		LB-62742CA (38H18) contains six stand-offs	
Low Ambient Control Kit		LB-57113BM (27J00)	
Timed-Off Control		LB-50709BA (32F21)	

ELECTRICAL DATA — CHP16H-261 AND CHP16-413-513-653

Model Number		CHP16H-261	CHP16-413	CHP16-513	CHP16-653
Line voltage data (50 hz)		220/240V (1 phase)	380/420V (3 phase with neutral)	380/420V (3 phase with neutral)	380/420V (3 phase with neutral)
Voltage range (minimum — maximum)		198V-264V	342-462V	342-462V	342-462V
Compressor	Rated load (A)	11.6	5.8	7.7	9.4
	Locked rotor (A)	56	40	64	73
Outdoor Coil Fan Motor (1 Phase)	Full load (A) (total)	1.5	1.4	1.1	1.1
	Locked rotor (A) (total)	2.1	2.9	2.0	2.0
Indoor Blower Motor	Full load (A)	2.6	2.6	3.4	3.4
	Locked rotor (A)	4.5	6.7	7.8	7.8

*Refer to local electrical codes to determine wire, fuse and disconnect size requirements. Use wires suitable for at least 75°C (167°F).

FIELD WIRING — BASIC MODELS

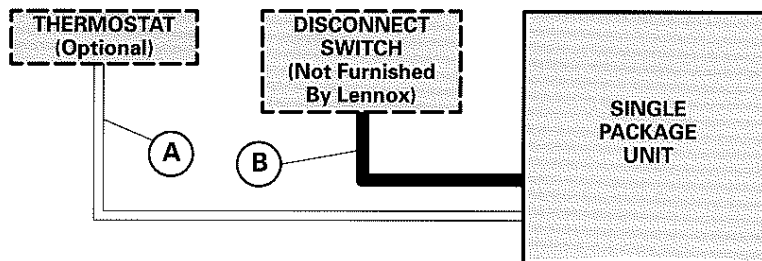

A — *Four Wire 24V (Electro-mechanical)

— *Six Wire 24V (Electronic)

*When Economizer with two stage cooling thermostat is used with
CHP16H-261, one additional wire is required.

B — Single or Three phase with neutral (See Electrical Data Table)

— Field Wiring Not Furnished —

NOTE — All wiring must conform to local electrical codes.

FIELD WIRING CHP16-413, -513 AND -653 MODELS ONLY

W973 CONTROL SYSTEM

- A — Three phase with neutral (See Electrical Data Table)
- B — Seven wire 24V — DC only
- Five wire 24V — DC only — with SSP11 Switching Status Panel
- Eight wire 24V — DC only — with switching subbase
- C — Two wire 24V — AC only — with switching subbase
- D — Two wire 24V — DC only
- E — Eleven wire 24V — AC only
- F — Two wire 24V — AC only
- G — Two wire 24V — AC only
- H — Fifteen wire 24V — AC only
- J — Two wire 24V — DC only

AC — Alternating current
DC — Direct current

NOTE — Run separate harnesses for AC and DC.
AC voltage interferes with DC signals.

— Field wiring not furnished —

NOTE — All wiring must conform to local electrical codes.

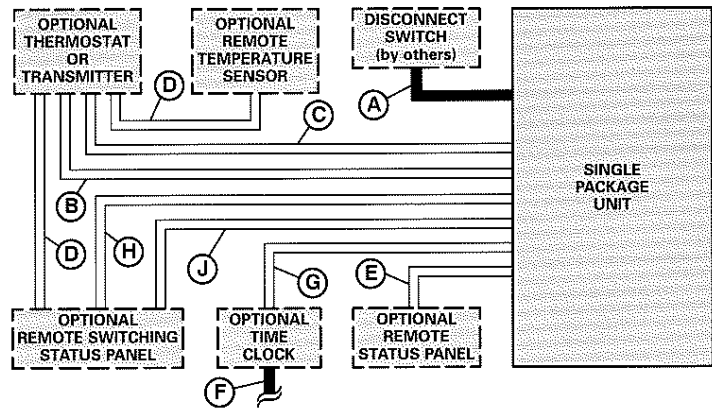

ELECTRO-MECHANICAL THERMOSTAT CONTROL SYSTEM

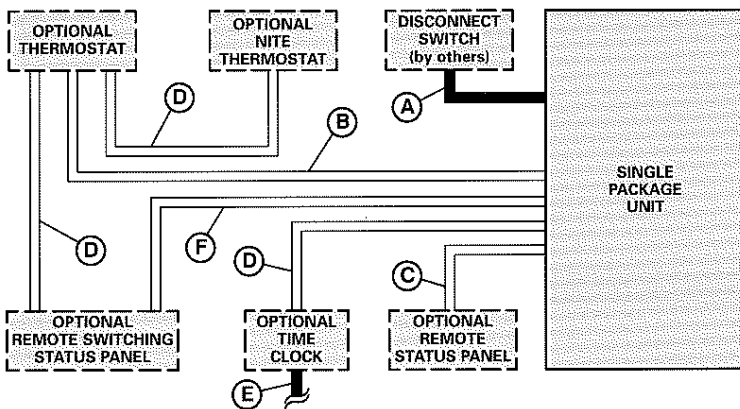

- A — Three phase with neutral (See Electrical Data Table)

- B — Six wire 24V
- Five wire 24V — with SSP11 Switching Status Panel
- Ten wire 24V — with Emergency Heat Switching Subbase

- C — Eleven wire 24V

- D — Two wire 24V

- E — Two wire 24V

- F — Eighteen wire 24V

— Field wiring not furnished —

NOTE — All wiring must conform to local electrical codes.

W7400 CONTROL SYSTEM

- A — Three phase with neutral (See Electrical Data Table)
- B — Two wire 24V
- C — Four wire 24V
- D — Eleven wire 24V

— Field wiring not furnished —

NOTE — All wiring must conform to local electrical codes.

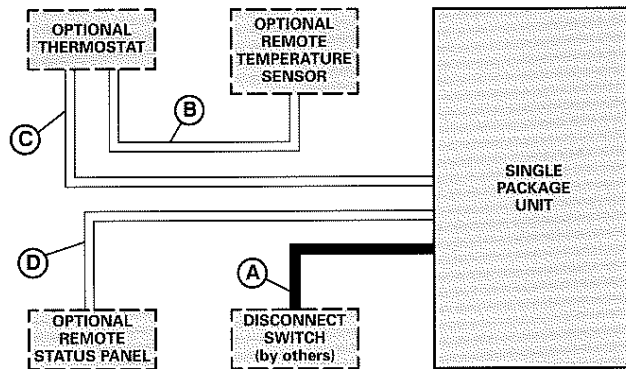

T7300 THERMOSTAT CONTROL SYSTEM

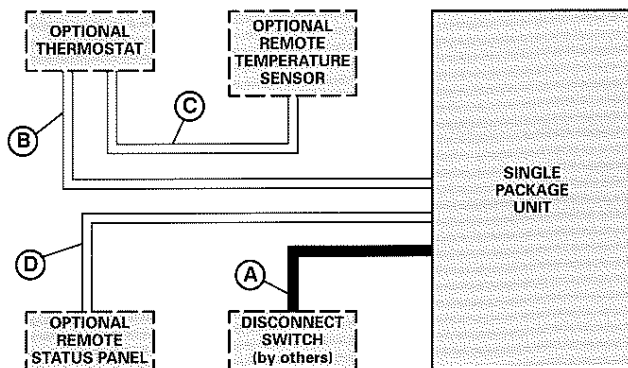

- A — Three phase with neutral (See Electrical Data Table)

- B — Nine wire 24V

- C — Two wire 24V

- Nine wire 24V (Room Sensor with Override)

- D — Eleven wire 24V

— Field wiring not furnished —

NOTE — All wiring must conform to local electrical codes.

OPTIONAL ELECTRIC HEAT DATA

Single Package Unit Model Number	Electric Heater Model Number and Net Weight	Number of Steps and Phase	Volts Input	Heating Capacity		Optional Single Point Power Source Boxes	
				kW	Btuh	Heater Sub-Fuse Box	Unit Sub-Fuse Box
CHP16H-261	ECH16R-5 (31H46) (2kg) (4 lbs.)	1 step (1 phase)	220	4.2	14 300	ECH16R-26/41-5 (31H26)	ECH16-261 (31H10)
			230	4.6	15 700		
			240	5.0	17 100		
	ECH16R-7 (31H47) (2kg) (5 lbs.)	1 step (1 phase)	220	5.9	20 100	ECH16R-26/65-7 (31H25)	
			230	6.4	21 900		
			240	7.0	23 900		
	ECH16R-10 (31H48) (2kg) (5 lbs.)	1 step (1 phase)	220	8.4	28 700	ECH16R-26/65-10 (31H24)	
			230	9.2	31 400		
			240	10.0	34 100		
	ECH16-15 (31H27) (8kg) (18 lbs.)	1 step (1 phase)	220	12.6	43 000	----	
			230	13.5	47 000		
			240	15.0	51 200		
CHP16-413	ECH16-7 (31H36) (9kg) (19 lbs.)	1 step (3 phase)	380	4.4	15 000	----	ECH16-413 (31H18)
			400	4.9	16 600		
			420	5.4	18 300		
	ECH16-10 (31H37) (9kg) (19 lbs.)	1 step (3 phase)	380	6.3	21 400	----	
			400	6.9	23 700		
			420	7.7	26 200		
	ECH16-15 (31H38) (9kg) (19 lbs.)	1 step (3 phase)	380	9.4	32 100	----	
			400	10.4	35 600		
			420	11.5	39 200		
	ECH16-20 (31H39) (9kg) (20 lbs.)	1 step (3 phase)	380	12.5	42 800	----	
			400	13.9	47 400		
			420	15.3	52 300		
CHP16-513 CHP16-653	ECH16-7 (31H36) (9kg) (19 lbs.)	1 step (3 phase)	380	4.4	15 000	----	ECH16-513/653 (31H19)
			400	4.9	16 600		
			420	5.4	18 300		
	ECH16-10 (31H37) (9kg) (19 lbs.)	1 step (3 phase)	380	6.3	21 400	----	
			400	6.9	23 700		
			420	7.7	26 200		
	ECH16-15 (31H38) (9kg) (19 lbs.)	1 step (3 phase)	380	9.4	32 100	----	
			400	10.4	35 600		
			420	11.5	39 200		
	ECH16-20 (31H39) (10kg) (22 lbs.)	1 step (3 phase)	380	12.5	42 800	----	
			400	13.9	47 400		
			420	15.3	52 300		
	ECH16-25 (31H40) (10kg) (22 lbs.)	1 step (3 phase)	380	15.6	53 400	----	
			400	17.4	59 300		
			420	19.2	65 400		

*Refer to local electrical code manual to determine wire, fuse and disconnect size requirements. Use wires suitable for at least 75°C (167°F).

RATINGS — 50hz

NOTE — For Temperatures and Capacities not shown in tables, see bulletin — Cooling Unit Rating Correction Factor Data in Miscellaneous Engineering Data section.

CHP16H-261 COOLING CAPACITY

Entering Wet Bulb Temperature	Total Air Volume		Outdoor Temperature																							
			29°C (85°F)						35°C (95°F)						41°C (105°F)						46°C (115°F)					
			Total Cooling Capacity		Compressor Motor kW	Sensible To Total Ratio (S/T) Dry Bulb			Total Cooling Capacity		Compressor Motor kW	Sensible To Total Ratio (S/T) Dry Bulb			Total Cooling Capacity		Compressor Motor kW	Sensible To Total Ratio (S/T) Dry Bulb			Total Cooling Capacity		Compressor Motor kW	Sensible To Total Ratio (S/T) Dry Bulb		
17.2°C (63°F)	330	700	6.4	21 900	1.64	.80	.96	1.00	6.1	20 700	1.74	.82	.99	1.00	5.8	19 700	1.86	.84	1.00	1.00	5.4	18 500	2.02	.87	1.00	1.00
	380	800	6.6	22 600	1.68	.83	1.00	1.00	6.3	21 400	1.76	.86	1.00	1.00	5.9	20 300	1.89	.89	1.00	1.00	5.7	19 300	2.05	.92	1.00	1.00
	425	900	6.8	23 200	1.67	.87	1.00	1.00	6.5	22 100	1.78	.90	1.00	1.00	6.2	21 000	1.92	.92	1.00	1.00	5.8	19 900	2.08	.96	1.00	1.00
19.4°C (67°F)	330	700	6.8	23 200	1.68	.62	.77	.92	6.4	21 900	1.78	.63	.79	.95	6.1	20 700	1.91	.64	.82	.98	5.7	19 500	2.06	.66	.85	1.00
	380	800	7.0	23 900	1.69	.64	.81	.97	6.6	22 500	1.80	.65	.83	.99	6.2	21 200	1.93	.67	.86	1.00	5.8	19 900	2.09	.69	.89	1.00
	425	900	7.2	24 400	1.70	.66	.84	1.00	6.7	23 000	1.81	.68	.87	1.00	6.4	21 700	1.94	.70	.90	1.00	5.9	20 300	2.11	.72	.93	1.00
21.7°C (71°F)	330	700	7.2	24 400	1.71	.46	.60	.75	6.8	23 200	1.82	.46	.62	.77	6.4	21 900	1.95	.47	.63	.79	6.0	20 600	2.12	.47	.65	.82
	380	800	7.4	25 100	1.72	.46	.63	.78	7.0	23 800	1.84	.47	.64	.80	6.6	22 400	1.98	.48	.65	.83	6.2	21 000	2.14	.48	.68	.87
	425	900	7.4	25 400	1.73	.48	.65	.82	7.1	24 200	1.85	.48	.67	.84	6.7	22 800	1.99	.49	.68	.88	6.2	21 300	2.16	.50	.71	.91

CHP16H-261 HEATING CAPACITY

Indoor Coil Air Volume 70°F db (21°C db)	*Air Temperature Entering Outdoor Coil																			
	65°F (18°C)				45°F (7°C)				25°F (-4°C)				5°F (-15°C)				-15°F (-28°C)			
	Total Heating Capacity		Comp. Motor Input	Total Heating Capacity		Comp. Motor Input	Total Heating Capacity		Comp. Motor Input	Total Heating Capacity		Comp. Motor Input	Total Heating Capacity		Comp. Motor Input	Total Heating Capacity		Comp. Motor Input		
	kW	Btuh		kW	Btuh		kW	Btuh		kW	Btuh		kW	Btuh		kW	Btuh		kW	Btuh
330	700	7.5	25 600	1.65	5.4	18 400	1.42	3.6	12 200	1.18	2.2	7 600	9.5	1.1	3 700	720				
380	800	7.6	26 000	1.62	5.5	18 900	1.39	3.7	12 600	1.15	2.3	8 000	9.2	1.2	4 100	690				
425	900	7.7	26 300	1.62	5.6	19 200	1.39	3.8	12 900	1.15	2.4	8 300	9.2	1.3	4 400	685				

*At 70% relative humidity.

NOTE — Heating capacities include the effect of defrost cycles in the temperature range where they occur.

CHP16-413 COOLING CAPACITY

Entering Wet Bulb Temperature	Total Air Volume		Outdoor Temperature																							
			29°C (85°F)						35°C (95°F)						41°C (105°F)						46°C (115°F)					
			Total Cooling Capacity		Compressor Motor kW	Sensible To Total Ratio (S/T) Dry Bulb			Total Cooling Capacity		Compressor Motor kW	Sensible To Total Ratio (S/T) Dry Bulb			Total Cooling Capacity		Compressor Motor kW	Sensible To Total Ratio (S/T) Dry Bulb			Total Cooling Capacity		Compressor Motor kW	Sensible To Total Ratio (S/T) Dry Bulb		
17.2°C (63°F)	495	1050	9.5	32 400	2.33	.76	.92	1.00	9.0	30 700	2.53	.77	.94	1.00	8.6	29 200	2.72	.79	.96	1.00	8.1	27 800	2.90	.80	.99	1.00
	565	1200	9.7	33 100	2.35	.79	.96	1.00	9.3	31 600	2.55	.80	.98	1.00	8.8	30 100	2.75	.82	1.00	1.00	8.4	28 600	2.95	.84	1.00	1.00
	635	1350	9.9	33 900	2.37	.82	1.00	1.00	9.5	32 400	2.58	.84	1.00	1.00	9.1	31 000	2.78	.85	1.00	1.00	8.6	29 500	2.99	.87	1.00	1.00
19.4°C (67°F)	495	1050	10.0	34 200	2.38	.60	.74	.89	9.6	32 600	2.58	.60	.76	.90	9.1	31 000	2.78	.61	.78	.92	8.6	29 200	2.98	.62	.80	.95
	565	1200	10.3	35 100	2.40	.61	.78	.93	9.8	33 300	2.61	.62	.80	.95	9.3	31 700	2.81	.63	.82	.97	8.8	29 900	3.01	.65	.84	1.00
	635	1350	10.5	35 700	2.42	.63	.81	.97	9.9	33 900	2.63	.64	.83	.99	9.5	32 300	2.83	.66	.86	1.00	8.9	30 500	3.03	.67	.88	1.00
21.7°C (71°F)	495	1050	10.5	35 800	2.43	.44	.59	.74	10.0	34 200	2.64	.45	.60	.76	9.6	32 600	2.85	.45	.61	.77	9.0	30 800	3.05	.465	.62	.79
	565	1200	10.8	36 800	2.45	.45	.61	.77	10.3	35 000	2.67	.46	.62	.79	9.8	33 300	2.88	.46	.63	.80	9.2	31 500	3.08	.46	.65	.82
	635	1350	11.0	37 400	2.47	.46	.63	.80	10.4	35 600	2.69	.46	.64	.82	9.9	33 800	2.90	.47	.66	.84	9.3	31 900	3.11	.47	.68	.86

CHP16-413 HEATING CAPACITY

Indoor Coil Air Volume 70°F db (21°C db)	*Air Temperature Entering Outdoor Coil																			
	65°F (18°C)				45°F (7°C)				25°F (-4°C)				5°F (-15°C)				-15°F (-28°C)			
	Total Heating Capacity		Comp. Motor Input	Total Heating Capacity		Comp. Motor Input	Total Heating Capacity		Comp. Motor Input	Total Heating Capacity		Comp. Motor Input	Total Heating Capacity		Comp. Motor Input	Total Heating Capacity		Comp. Motor Input		
	kW	Btuh		kW	Btuh		kW	Btuh		kW	Btuh		kW	Btuh		kW	Btuh		kW	Btuh
495	1050	12.9	44 200	2.69	9.0	30 600	2.08	5.6	19 100	1.77	3.7	12 600	1.43	1.8	6 120	1.08				
565	1200	13.2	45 000	2.65	9.2	31 400	2.03	5.8	19 800	1.73	3.9	13 300	1.38	2.0	6 800	1.03				
635	1350	13.3	45 300	2.61	9.3	31 700	2.00	5.8	19 900	1.70	4.0	13 600	1.35	2.1	7 110	1.00				

*At 70% relative humidity.

NOTE — Heating capacities include the effect of defrost cycles in the temperature range where they occur.

RATINGS — 50hz

NOTE — For Temperatures and Capacities not shown in tables, see bulletin — Cooling Unit Rating Correction Factor Data in Miscellaneous Engineering Data section.

CHP16-513 COOLING CAPACITY

Entering Wet Bulb Temperature	Total Air Volume		Outdoor Temperature																							
			29°C (85°F)						35°C (95°F)						41°C (105°F)						46°C (115°F)					
			Total Cooling Capacity		Compressor Motor kW	Sensible To Total Ratio (S/T)			Total Cooling Capacity		Compressor Motor kW	Sensible To Total Ratio (S/T)			Total Cooling Capacity		Compressor Motor kW	Sensible To Total Ratio (S/T)			Total Cooling Capacity		Compressor Motor kW	Sensible To Total Ratio (S/T)		
						Dry Bulb						Dry Bulb						Dry Bulb						Dry Bulb		
L/s	cfm	kW	Btuh	kW	24°C/75°F	27°C/80°F	29°C/85°F	kW	Btuh	kW	24°C/75°F	27°C/80°F	29°C/85°F	kW	Btuh	kW	24°C/75°F	27°C/80°F	29°C/85°F	kW	Btuh	kW	24°C/75°F	27°C/80°F	29°C/85°F	
17.2°C (63°F)	660	1400	12.3	42 100	3.03	.76	.91	1.00	11.7	40 000	3.21	.77	.94	1.00	11.1	37 800	3.42	.79	.97	1.00	10.4	35 500	3.64	.81	.99	1.00
	755	1600	12.7	43 200	3.09	.79	.96	1.00	12.0	40 900	3.27	.80	.98	1.00	11.3	38 700	3.47	.82	1.00	1.00	10.7	36 600	3.69	.84	1.00	1.00
	850	1800	12.9	44 100	3.14	.82	.99	1.00	12.3	42 000	3.32	.84	1.00	1.00	11.7	39 900	3.53	.85	1.00	1.00	11.0	37 700	3.74	.88	1.00	1.00
19.4°C (67°F)	660	1400	13.0	44 400	3.16	.59	.74	.88	12.4	42 200	3.33	.60	.76	.90	11.7	39 800	3.52	.61	.78	.93	11.0	37 400	3.72	.63	.80	.95
	755	1600	13.3	45 500	3.22	.61	.78	.93	12.7	43 200	3.38	.62	.80	.95	12.0	40 800	3.56	.64	.82	.97	11.2	38 100	3.76	.65	.85	1.00
	850	1800	13.6	46 400	3.26	.63	.81	.97	12.9	44 000	3.42	.64	.83	.99	12.1	41 400	3.60	.66	.86	1.00	11.4	38 800	3.78	.67	.89	1.00
21.7°C (71°F)	660	1400	13.7	46 600	3.27	.44	.58	.74	13.0	44 200	3.44	.45	.60	.76	12.3	41 800	3.62	.45	.61	.77	11.5	39 300	3.81	.46	.62	.79
	755	1600	14.0	47 600	3.32	.45	.61	.77	13.2	45 200	3.48	.46	.62	.79	12.5	42 700	3.66	.46	.63	.81	11.8	40 100	3.84	.47	.65	.83
	850	1800	14.2	48 600	3.37	.46	.63	.80	13.5	46 100	3.52	.46	.64	.82	12.7	43 500	3.69	.47	.66	.84	12.0	40 800	3.86	.48	.68	.86

CHP16-513 HEATING CAPACITY

Indoor Coil Air Volume 70°F db (21°C db)	*Air Temperature Entering Outdoor Coil																			
	65°F (18°C)				45°F (7°C)				25°F (-4°C)				5°F (-15°C)				-15°F (-28°C)			
	Total Heating Capacity		Comp. Motor Input	Total Heating Capacity		Comp. Motor Input	Total Heating Capacity		Comp. Motor Input	Total Heating Capacity		Comp. Motor Input	Total Heating Capacity		Comp. Motor Input	Total Heating Capacity		Comp. Motor Input		
	kW	Btuh		kW	Btuh		kW	Btuh		kW	Btuh		kW	Btuh		kW	Btuh			
660	1400	17.2	58 800	3.59	11.9	40 700	2.73	7.4	25 300	2.29	4.9	16 800	1.84	2.4	8200	1.39				
755	1600	17.5	59 700	3.51	12.2	41 600	2.66	7.6	26 100	2.21	5.2	17 600	1.77	2.6	9000	1.32				
850	1800	17.7	60 500	3.45	12.4	42 300	2.6	7.8	26 800	2.15	5.4	18 300	1.71	2.8	9700	1.26				

*At 70% relative humidity.

NOTE — Heating capacities include the effect of defrost cycles in the temperature range where they occur.

CHP16-653 COOLING CAPACITY

Entering Wet Bulb Temperature	Total Air Volume		Outdoor Temperature																							
			29°C (85°F)						35°C (95°F)						41°C (105°F)						46°C (115°F)					
			Total Cooling Capacity		Compressor Motor kW	Sensible To Total Ratio (S/T)			Total Cooling Capacity		Compressor Motor kW	Sensible To Total Ratio (S/T)			Total Cooling Capacity		Compressor Motor kW	Sensible To Total Ratio (S/T)			Total Cooling Capacity		Compressor Motor kW	Sensible To Total Ratio (S/T)		
						Dry Bulb						Dry Bulb						Dry Bulb						Dry Bulb		
L/s	cfm	kW	Btuh	kW	24°C/75°F	27°C/80°F	29°C/85°F	kW	Btuh	kW	24°C/75°F	27°C/80°F	29°C/85°F	kW	Btuh	kW	24°C/75°F	27°C/80°F	29°C/85°F	kW	Btuh	kW	24°C/75°F	27°C/80°F	29°C/85°F	
17.2°C (63°F)	825	1750	15.1	51 600	3.54	.76	.92	1.00	14.4	49 200	3.84	.77	.94	1.00	13.8	47 000	4.14	.79	.97	1.00	13.0	44 400	4.42	.80	.99	1.00
	945	2000	15.3	52 300	3.58	.79	.96	1.00	14.8	50 500	3.88	.81	.98	1.00	14.1	48 000	4.18	.82	1.00	1.00	13.4	45 600	4.49	.84	1.00	1.00
	1060	2250	15.7	53 500	3.62	.82	1.00	1.00	15.2	51 700	3.92	.84	1.00	1.00	14.5	49 400	4.24	.86	1.00	1.00	13.8	47 000	4.55	.87	1.00	1.00
19.4°C (67°F)	825	1750	16.1	54 800	3.62	.60	.75	.88	15.3	52 200	3.93	.61	.76	.90	14.5	49 500	4.24	.62	.78	.92	13.8	47 000	4.54	.63	.80	.94
	945	2000	16.4	56 000	3.65	.62	.78	.93	15.7	53 500	3.97	.63	.80	.94	14.9	50 800	4.28	.64	.82	.97	14.1	48 000	4.58	.65	.84	.99
	1060	2250	16.8	57 200	3.68	.64	.81	.97	16.0	54 500	4.00	.65	.83	.99	15.2	51 700	4.32	.66	.85	1.00	14.2	48 500	4.61	.67	.88	1.00
21.7°C (71°F)	825	1750	16.8	57 300	3.68	.45	.59	.74	16.0	54 700	4.01	.45	.60	.76	15.2	51 900	4.34	.46	.61	.77	14.4	49 300	4.65	.46	.62	.79
	945	2000	17.2	58 600	3.72	.46	.61	.77	16.4	55 900	4.05	.46	.62	.79	15.6	53 100	4.38	.46	.63	.80	14.7	50 300	4.69	.47	.65	.82
	1060	2250	17.5	59 700	3.75	.46	.63	.80	16.7	57 100	4.08	.47	.64	.82	15.9	54 200	4.41	.47	.66	.84	15.0	51 100	4.73	.48	.68	.86

CHP16-653 HEATING CAPACITY

Indoor Coil Air Volume 70°F db (21°C db)	*Air Temperature Entering Outdoor Coil																			
	65°F (18°C)				45°F (7°C)				25°F (-4°C)				5°F (-15°C)				-15°F (-28°C)			
	Total Heating Capacity		Comp. Motor Input	Total Heating Capacity		Comp. Motor Input	Total Heating Capacity		Comp. Motor Input	Total Heating Capacity		Comp. Motor Input	Total Heating Capacity		Comp. Motor Input	Total Heating Capacity		Comp. Motor Input		
	kW	Btuh		kW	Btuh		kW	Btuh		kW	Btuh		kW	Btuh		kW	Btuh			
825	1750	20.7	70 900	4.68	14.9	50 900	3.78	9.5	32 600	3.24	6.4	21 800	2.61	3.1	10 600	1.97				
945	2000	21.1	72 000	4.57	15.2	51 900	3.67	9.8	33 600	3.13	6.7	22 800	2.50	3.4	11 700	1.87				
1060	2250	21.3	72 900	4.48	15.5	52 800	3.6	10.0	34 400	3.06	6.9	23 700	2.42	3.6	12 400	1.78				

*At 70% relative humidity.

NOTE — Heating capacities include the effect of defrost cycles in the temperature range where they occur.

BLOWER DATA

**CHP16H-261 BLOWER PERFORMANCE — 50 hz
(With Horizontal Air Openings)**

External Static Pressure		Air Volume at Various Blower Speeds					
		High		Medium		Low	
Pa	in. w.g.	L/s	cfm	L/s	cfm	L/s	cfm
0	0	525	1110	370	780	280	590
25	0.10	500	1060	350	740	270	570
50	0.20	480	1020	340	720	250	530
75	0.30	460	980	320	680	240	510
100	0.40	430	910	300	640	220	470
125	0.50	390	830	280	590	200	420
150	0.60	360	760	250	530	180	380
175	0.70	320	680	220	470	160	340
185	0.75	280	590	200	420	130	280

NOTE — All air data is measured external to the unit without air filter.

**CHP16-413 BLOWER PERFORMANCE — 50 hz
(With Down-Flo Air Openings)**

External Static Pressure		Air Volume at Various Blower Speeds							
		High		Medium-High		Medium-Low		Low	
Pa	in. w.g.	L/s	cfm	L/s	cfm	L/s	cfm	L/s	cfm
0	0	550	1170	475	1010	445	940	360	760
25	0.10	540	1140	470	1000	430	910	350	740
50	0.20	520	1100	460	980	420	890	340	720
75	0.30	510	1080	450	950	410	870	330	700
100	0.40	480	1040	430	910	400	850	310	660
125	0.50	470	1000	420	890	380	810	300	640
150	0.60	450	950	400	850	360	760	280	590
175	0.70	420	890	380	810	350	740	270	570
185	0.75	400	850	360	760	330	700	250	530

NOTE — All air data is measured external to the unit without air filter.

**CHP16-413 BLOWER PERFORMANCE — 50 hz
(With Horizontal Air Openings)**

External Static Pressure		Air Volume at Various Blower Speeds							
		High		Medium-High		Medium-Low		Low	
Pa	in. w.g.	L/s	cfm	L/s	cfm	L/s	cfm	L/s	cfm
0	0	580	1230	505	1070	450	950	360	760
25	0.10	570	1210	500	1060	440	930	350	740
50	0.20	550	1170	480	1020	430	910	340	720
75	0.30	540	1140	470	1000	420	890	330	700
100	0.40	520	1100	450	950	400	850	320	680
125	0.50	500	1060	430	910	390	830	300	640
150	0.60	470	1000	410	870	370	780	280	590
175	0.70	450	950	390	830	350	740	270	570
185	0.75	430	910	370	780	330	700	250	530

NOTE — All air data is measured external to the unit without air filter.

**CHP16-513 BLOWER PERFORMANCE — 50 hz
(With Horizontal or Down-Flo Air Openings)**

External Static Pressure		Air Volume at Various Blower Speeds					
		High		Medium		Low	
Pa	in. w.g.	L/s	cfm	L/s	cfm	L/s	cfm
0	0	845	1790	710	1500	470	1000
25	0.10	820	1740	690	1460	470	1000
50	0.20	790	1670	680	1440	460	980
75	0.30	770	1630	660	1400	450	950
100	0.40	730	1550	640	1360	440	930
125	0.50	690	1460	620	1310	430	910
150	0.60	650	1380	590	1250	420	890
175	0.70	610	1290	560	1190	410	870
185	0.75	560	1190	530	1120	390	830

NOTE — All air data is measured external to the unit without air filter.

**CHP16-653 BLOWER PERFORMANCE — 50 hz
(With Down-Flo Air Openings)**

External Static Pressure		Air Volume at Various Blower Speeds					
		High		Medium		Low	
Pa	in. w.g.	L/s	cfm	L/s	cfm	L/s	cfm
0	0	855	1810	780	1650	695	1470
25	0.10	840	1780	760	1610	680	1440
50	0.20	820	1740	740	1570	670	1420
75	0.30	800	1700	730	1550	660	1400
100	0.40	770	1630	700	1480	640	1360
125	0.50	750	1590	680	1440	630	1340
150	0.60	710	1510	650	1380	610	1290
175	0.70	690	1460	620	1310	590	1250
185	0.75	650	1380	590	1250	570	1210

NOTE — All air data is measured external to the unit without air filter.

**CHP16-653 BLOWER PERFORMANCE — 50 hz
(With Horizontal Air Openings)**

External Static Pressure		Air Volume at Various Blower Speeds					
		High		Medium		Low	
Pa	in. w.g.	L/s	cfm	L/s	cfm	L/s	cfm
0	0	970	2060	860	1840	745	1580
25	0.10	950	2010	850	1800	730	1550
50	0.20	930	1970	830	1760	720	1530
75	0.30	910	1930	810	1720	700	1480
100	0.40	880	1870	780	1650	680	1440
125	0.50	850	1800	750	1590	660	1400
150	0.60	810	1720	720	1530	630	1340
175	0.70	770	1630	690	1460	610	1290
185	0.75	730	1550	650	1380	580	1230

NOTE — All air data is measured external to the unit without air filter.

ACCESSORY BLOWER DATA

FILTER AND ACCESSORY AIR RESISTANCE

Unit Model Number	Air Volume		Total Air Resistance — Pa (inches water gauge)							
			25mm (1in.) Filter Furnished With CHP16 Units	REMD16 Down-Flo Economizer			*RDE16-31 Duct Enclosure	EMDH16 Horizontal Economizer		
	L/s	cfm		With 25mm (1in.) Filter Not Furnished	Less Filter	Optional Pleated Polyester 51mm (2in.) Filter		Optional Fiberglass 51mm (2in.) Filter	25mm (1in.) Filter Furnished	Less Filter
CHP16H-261	380	800	----	67 (0.27)	12 (0.05)	67 (0.27)	32 (0.13)	27 (0.11)	----	----
	470	1000	----	85 (0.34)	15 (0.06)	85 (0.34)	45 (0.18)	47 (0.19)	----	----
	565	1200	----	104 (0.42)	22 (0.09)	104 (0.42)	60 (0.24)	55 (0.22)	----	----
CHP16-413	380	800	37 (0.15)	37 (0.15)	12 (0.05)	67 (0.27)	32 (0.13)	----	45 (0.18)	25 (0.10)
	470	1000	45 (0.18)	45 (0.18)	15 (0.06)	85 (0.34)	45 (0.18)	----	65 (0.26)	37 (0.15)
	565	1200	52 (0.21)	52 (0.21)	22 (0.09)	104 (0.42)	60 (0.24)	----	87 (0.35)	52 (0.21)
	660	1400	62 (0.25)	62 (0.25)	37 (0.15)	127 (0.51)	77 (0.31)	----	114 (0.46)	72 (0.29)
CHP16-513 CHP16-653	755	1600	37 (0.15)	50 (0.20)	12 (0.05)	99 (0.40)	67 (0.27)	----	75 (0.30)	42 (0.17)
	850	1800	42 (0.17)	57 (0.23)	15 (0.06)	119 (0.48)	82 (0.33)	----	87 (0.35)	47 (0.19)
	945	2000	50 (0.20)	67 (0.27)	20 (0.08)	139 (0.56)	97 (0.39)	----	99 (0.40)	55 (0.22)
	1040	2200	57 (0.23)	80 (0.32)	32 (0.13)	164 (0.66)	114 (0.46)	----	117 (0.47)	65 (0.26)

NOTE — Electric heaters have no appreciable air resistance.
*Air resistance is with filter in place.

DIFFUSER AIR RESISTANCE

Unit Model Number	Air Volume		Total Air Resistance — Pa (inches water gauge)			
			RTD9-65 Diffuser			FD9-65 Diffuser
	L/s	cfm	2 Ends Open	1 Side 2 Ends Open	All Ends & Sides Open	
CHP16H-261	380	800	37 (0.15)	32 (0.13)	27 (0.11)	27 (0.11)
	470	1000	47 (0.19)	40 (0.16)	35 (0.14)	35 (0.14)
	565	1200	62 (0.25)	50 (0.20)	42 (0.17)	42 (0.17)
CHP16-413	380	800	37 (0.15)	32 (0.13)	27 (0.11)	27 (0.11)
	470	1000	47 (0.19)	40 (0.16)	35 (0.14)	35 (0.14)
	565	1200	62 (0.25)	50 (0.20)	42 (0.17)	42 (0.17)
	660	1400	82 (0.33)	65 (0.26)	50 (0.20)	50 (0.20)
CHP16-513 CHP16-653	755	1600	107 (0.43)	80 (0.32)	60 (0.24)	60 (0.24)
	850	1800	139 (0.56)	90 (0.40)	75 (0.30)	75 (0.30)
	945	2000	182 (0.73)	124 (0.50)	90 (0.36)	90 (0.36)
	1040	2200	236 (0.95)	157 (0.63)	109 (0.44)	109 (0.44)

ACCESSORY BLOWER DATA

RTD9-65 STEP-DOWN CEILING DIFFUSER AIR THROW DATA

Grille Vanes	Air Volume		*Effective Throw — m (ft.)		
	L/s	cfm	Horizontal Vanes 180° Straight	Horizontal Vanes 22° Down	Horizontal Vanes 45° Down
2 Ends Open	285	600	6.5 (21)	6.0 (20)	4.5 (14)
	380	800	6.5 (22)	6.5 (21)	4.5 (15)
	470	1000	7.5 (24)	6.5 (22)	5.0 (16)
	565	1200	7.5 (25)	7.0 (23)	5.0 (17)
	660	1400	8.0 (27)	7.5 (25)	5.5 (18)
	755	1600	9.0 (29)	8.0 (26)	6.0 (19)
	850	1800	9.5 (31)	8.0 (27)	6.0 (20)
	945	2000	10.0 (33)	8.5 (28)	6.5 (21)
	1040	2200	10.5 (35)	9.0 (30)	6.5 (22)
	1135	2400	11.5 (38)	10.5 (34)	7.0 (23)
1 Side 2 Ends Open	285	600	4.5 (15)	4.5 (14)	2.5 (8)
	380	800	5.0 (16)	4.5 (15)	2.5 (9)
	470	1000	5.0 (17)	5.0 (16)	3.0 (10)
	565	1200	5.5 (18)	5.0 (17)	3.5 (11)
	660	1400	6.0 (19)	5.5 (18)	3.5 (12)
	755	1600	6.0 (20)	5.5 (18)	3.5 (12)
	850	1800	6.5 (21)	6.0 (19)	4.0 (13)
	945	2000	7.0 (23)	6.0 (20)	4.5 (14)
	1040	2200	7.5 (25)	6.5 (22)	5.0 (16)
	1135	2400	8.0 (27)	7.5 (24)	5.0 (17)
All Sides And Ends Open	285	600	3.5 (11)	3.0 (10)	2.0 (7)
	380	800	3.5 (12)	3.5 (11)	2.5 (8)
	470	1000	4.0 (13)	3.5 (12)	2.5 (8)
	565	1200	4.5 (14)	4.0 (13)	2.5 (9)
	660	1400	4.5 (15)	4.5 (14)	2.5 (9)
	755	1600	5.0 (16)	4.5 (14)	3.0 (10)
	850	1800	5.0 (17)	4.5 (15)	3.0 (10)
	945	2000	5.5 (18)	5.0 (16)	3.5 (11)
	1040	2200	6.0 (19)	5.0 (17)	3.5 (12)
	1135	2400	6.0 (20)	5.5 (18)	3.5 (12)

*Effective throw is determined at a point where conditioned air velocity has decreased to 15m (50 ft.) per minute.

WET INDOOR COIL AIR RESISTANCE

Model Number	Air Volume		Air Resistance Pa (inches water gauge)
	L/s	cfm	
CHP16H-261	285	600	10 (0.04)
	380	800	12 (0.05)
	470	1000	15 (0.06)
CHP16-413	380	800	17 (0.07)
	470	1000	20 (0.08)
	565	1200	22 (0.09)
	660	1400	25 (0.10)
CHP16-513	755	1600	32 (0.13)
	850	1800	35 (0.14)
	945	2000	37 (0.15)
	1040	2200	40 (0.16)
CHP16-653	755	1600	27 (0.11)
	850	1800	30 (0.12)
	945	2000	32 (0.13)
	1040	2200	35 (0.14)

FD9-65 FLUSH CEILING DIFFUSER AIR THROW DATA

Air Volume		*Effective Throw — m (ft.)
L/s	cfm	
285	600	2.0 (7)
380	800	2.5 (8)
470	1000	2.5 (8)
565	1200	2.5 (9)
660	1400	2.5 (9)
755	1600	3.0 (10)
850	1800	3.5 (11)
945	2000	3.5 (12)
1040	2200	3.5 (12)
1135	2400	4.0 (13)

*Effective throw is determined at a point where conditioned air velocity has decreased to 15m (50 ft.) per minute.

GUIDE SPECIFICATIONS

Prepared for the guidance of architects, consulting engineers and mechanical contractors.

General — Furnish and install a single package heat pump unit, complete with automatic controls. The single package unit shall be a standard product of a firm regularly engaged in the manufacture of heating-cooling equipment.

The installed weight shall not be more than kg (lbs.). Entire unit shall have a width of not more than mm (inches), a depth of not more than mm (inches), and an overall height of not more than mm (inches). The equipment shall be shipped completely factory assembled, precharged, piped and wired internally ready for field connections. In addition, manufacturer shall test operate system at the factory before shipment.

Air Distribution — Equipment shall be capable of bottom (down-flow) or side (horizontal) handling of conditioned air. All air distribution ducts shall be fiberglass or galvanized steel insulated with mm (inch) thick kg/m³ (lb./ft.³) density fiberglass or equivalent.

Cooling System — The total cooling capacity shall not be less than kW (Btuh) with an indoor air volume of (L/s) (cfm), an entering wet bulb air temperature of °C (°F), an entering dry bulb air temperature of °C (°F) and an outdoor entering temperature of °C (°F). The compressor power input shall not exceed kW at these conditions.

Heating System — The total heating capacity shall not be less than kW (Btuh) with an indoor air volume of (L/s) (cfm), an entering wet bulb air temperature of °C (°F), an entering dry bulb air temperature of °C (°F) and an outdoor coil entering air temperature of °C (°F). The compressor power input shall not exceed kW at these conditions.

The coils shall be non-ferrous construction with aluminum fins mechanically bonded to durable copper tubes. Coils shall be pressure leak tested. Coil face area shall be not less than m² (ft.²) (indoor) and m² (ft.²) (outdoor). Optional coil guard(s) shall be available.

The compressor shall be resiliently mounted, have overload protection, and internal pressure relief. All models shall have compressor crankcase heater. The refrigeration system shall have suction and liquid line service valves with gauge ports, reversing valve and full refrigerant charge. CHP16H-261 and CHP16-413 models shall have refrigerant metering/flow control device. CHP16-513 and -653 models shall have check and expansion valve, suction line accumulator and thermometer well. CHP16-413, -513 and -653 models shall have high pressure switch and loss of charge switch. Control option available shall consist of low ambient control and timed-off control.

CHP16-413, -513 and -653 Models Commercial Controls Platform — Shall be furnished and factory installed. Platform shall include control system and economizer wiring harness. Wiring harness shall be used in conjunction with thermostats, related control systems and economizer dampers.

Cabinet — Shall be galvanized steel with a powdered enamel paint finish electrostatically bonded to the metal. Cabinet panels where conditioned air is handled shall be fully insulated to prevent sweating and minimize sound. Openings shall be provided for power connection entry. Supply and return air openings shall be flanged. Indoor coil condensate drain extended outside cabinet shall be provided. CHP16-413, -513 and -653 models shall have low voltage terminal strip. Lifting brackets shall be provided for rigging on CHP16-413, -513 and -653 (optional for CHP16H-261).

Service Access — All components, wiring and inspection areas shall be completely accessible through removable panels.

Air Movers — Centrifugal conditioned air blower shall be direct driven by a multi-speed motor and be capable of delivering L/s (cfm) at an external static pressure of Pa (inches water gauge) requiring not more than kW (bhp) and rev/min. Blower wheel shall be statically and dynamically balanced.

Outdoor Coil Fan — Propeller type outdoor coil fan shall be direct driven by a W (hp) motor. Fan motor shall be permanently lubricated and inherently protected. Fan shall have a safety guard.

OPTIONAL ACCESSORIES

Supplemental Electric Heaters — The certified total heating capacity output shall be kW (Btuh) at volts power supply.

Optional electric heaters shall be field installed. Heating elements shall be nichrome bare wire exposed directly to the air stream. ECH16R safety devices shall consist of limit controls and thermal cut-off safety fuses. ECH16 safety devices shall consist of limit controls and fuse block. Optional heater sub-fuse box shall be available for ECH16R electric heaters for single point power supply applications.

Roof Mounting Frame — Furnish and install a steel roof mounting frame for bottom discharge and return air duct connection. It shall mate to the bottom perimeter of the equipment. When flashed into the roof it shall make a unit mounting curb and provide weatherproof duct connection and entry into the conditioned area. Flashing shall be the responsibility of a roofing contractor.

Duct Enclosure — Enclosure shall attach to the CHP16H-261 single package unit and mate to the roof mounting frame providing weatherproof duct connection and entry into the conditioned area. Enclosure shall be of galvanized steel with baked-on enamel paint finish and shall be completely insulated. Shall include minimum outdoor air intake damper and disposable air filter with not less than m²(ft²) of free area

Economizer Damper Section — Furnish and install complete with controls and air mixing damper assembly including outside air and recirculated air dampers. REMD16 shall include pressure operated gravity exhaust dampers. The assembly shall provide for the introduction of outside air for minimum ventilation and free cooling. Damper motor shall be 24 volt three position or fully modulating spring return. Controls shall be include electronic discharge air sensor, minimum position switch, and solid state-state adjustable enthalpy control. Control option available shall consist of differential enthalpy control (return air sensor).

Horizontal Gravity Exhaust Dampers — Pressure operated dampers shall install in return air duct for horizontal application. Damper blades shall ride in nylon bearings and be gasketed for tight seal and quiet operation.

Outdoor Air Damper Section — Optional outdoor dampers shall be available to provide outdoor air requirements of up to 25%. Damper section field installs external to the unit. Shall be equipped with filter for extra air filtering and bird screen protection.

Roof Curb Power Entry Kit — Optional kit shall provide power entry to the unit through the roof mounting frame.

Stand-Off Mounting Kit — Optional kit shall be available to elevate unit above mounting surface in horizontal applications.

Ceiling Diffusers — Furnish and install a (flush or stepdown) optional combination ceiling supply and return air diffuser. It shall be capable of not less than m (ft.) radius of effective throw. Supply and return transitions shall be available, for field installation in the roof mounting frame, to provide duct connection to the diffuser.

Single Point Power Source Unit Sub-Fuse Box — Optional box shall field install internal to the unit and provide single point power source connection and sub-fusing for unit. Shall be of galvanized steel with mounting holes, electric inlets and hinged cover.

Remote Status Panel — Shall be available for installation within the conditioned area to observe equipment operation. The panel shall include signal lights for Cool Mode, Heat Mode, Compressor 1, Compressor 2 (not required), No Heat and Filter.

Remote Switching Status Panel — Shall be available for installation within the conditioned area to control and observe equipment operation. The panel shall include signal lights for Cool Mode, Heat Mode, Compressor 1, Compressor 2 (not required), No Heat and Filter. System selector switch and fan switch shall provide operational mode and blower operation. After hours timer switch shall override night setback controls and provide normal operation for time period set.

Control Systems — Shall provide a selection of thermostats and related controls to automatically operate the mechanical equipment through the heating or cooling and ventilating cycles as required.

DIMENSIONS — inches (mm)

CHP16H-261 BASIC UNIT

CORNER WEIGHTS

Model Number	AA		BB		CC		DD	
	lbs.	kg	lbs.	kg	lbs.	kg	lbs.	kg
CHP16H-261	67	30	56	25	82	37	98	44

CENTER OF GRAVITY

Model Number	EE		FF	
	inch	mm	inch	mm
CHP16H-261	17-7/8	454	27-5/16	694

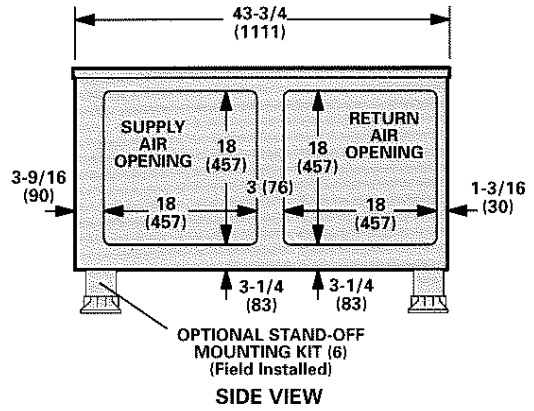
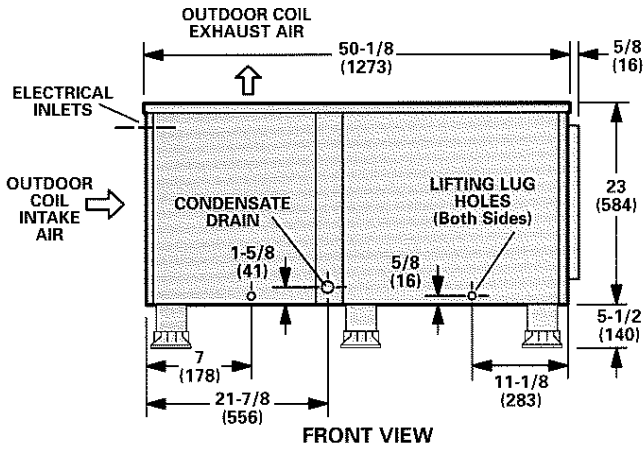
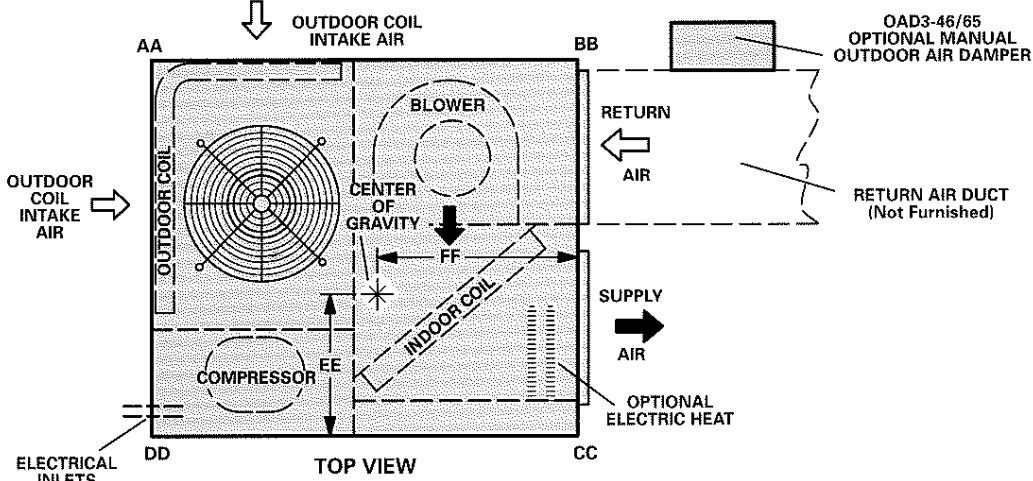

INSTALLATION CLEARANCES — inches (mm)

CHP16H-261 BASIC UNIT WITH OAD3-46/65 OUTDOOR AIR DAMPER

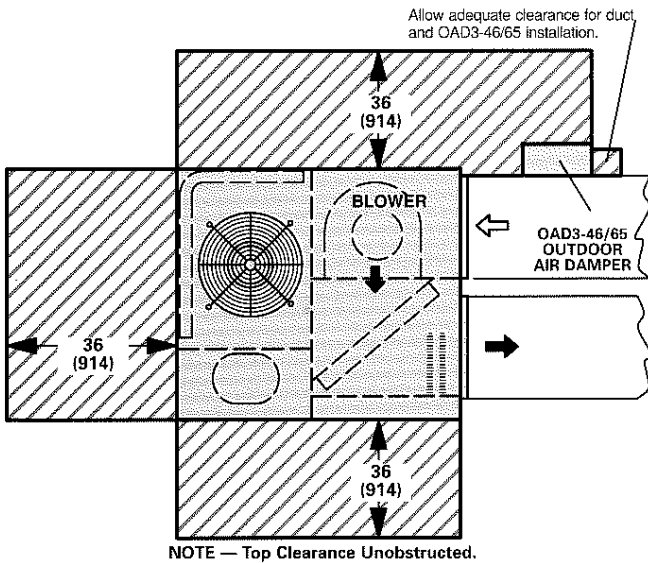

CHP16H-261 UNIT WITH RDE16-31 DUCT ENCLOSURE AND REMD16-41 ECONOMIZER DAMPER SECTION

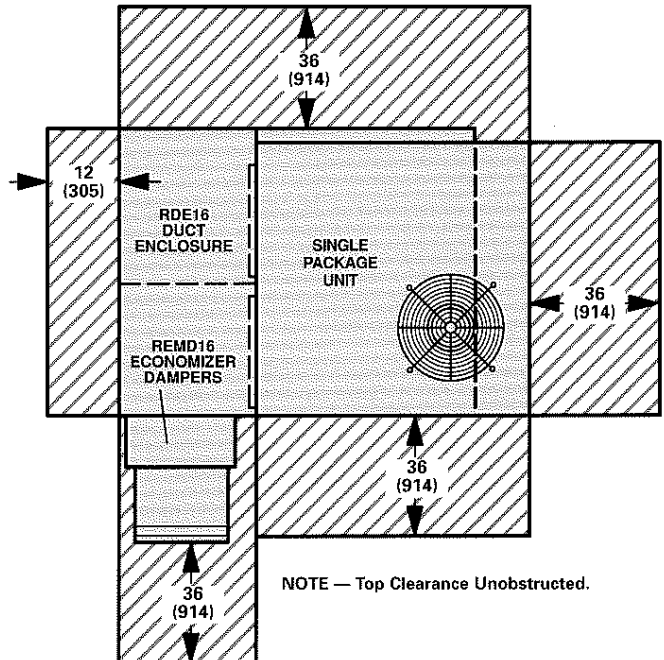

OPTIONAL ACCESSORY DIMENSIONS — inches (mm)

CHP16H-261 WITH RDE16-31 DUCT ENCLOSURE AND RMF16-31 ROOF MOUNTING FRAME

CORNER WEIGHTS

Model Number	AA		BB		CC		DD	
	lbs.	kg	lbs.	kg	lbs.	kg	lbs.	kg
CHP16H-261	116	53	143	65	120	54	98	44

CENTER OF GRAVITY

Model Number	EE		FF	
	inch	mm	inch	mm
CHP16H-261	24-3/4	629	33-7/16	824

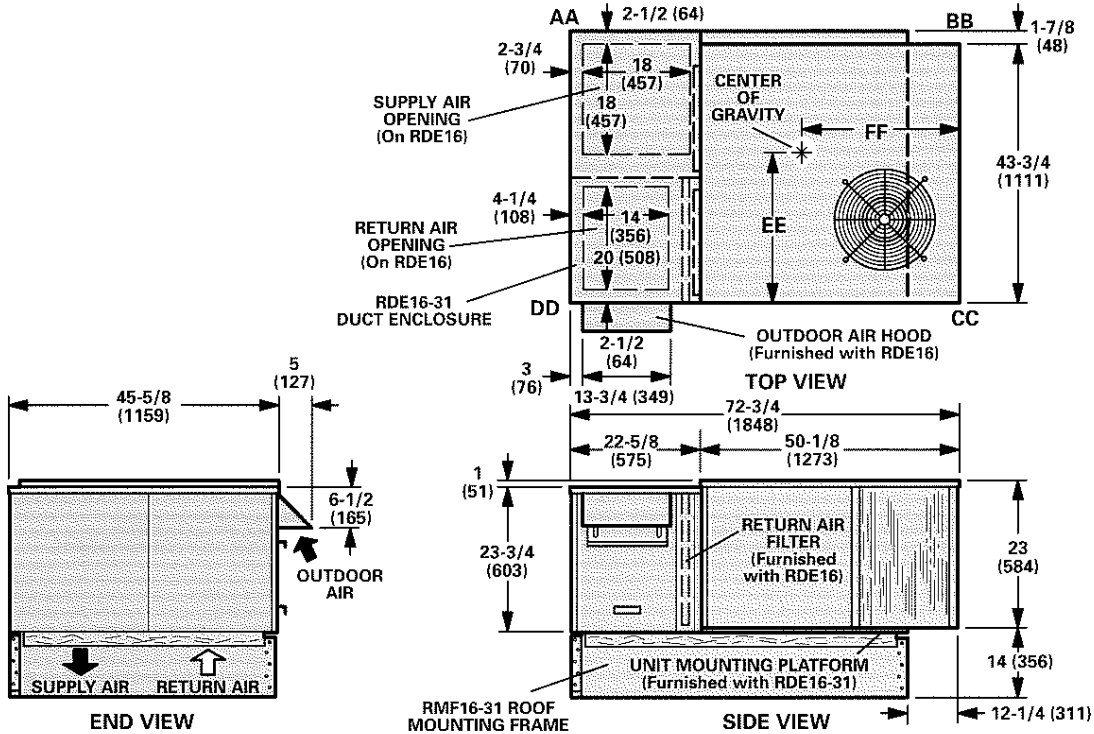

CHP16H-261 WITH REMD16-41 ECONOMIZER, RDE16-31 DUCT ENCLOSURE AND RMF16-31 ROOF MOUNTING FRAME

CORNER WEIGHTS

Model Number	AA		BB		CC		DD	
	lbs.	kg	lbs.	kg	lbs.	kg	lbs.	kg
CHP16H-261	122	55	138	63	141	64	124	56

CENTER OF GRAVITY

Model Number	EE		FF	
	inch	mm	inch	mm
CHP16H-261	22-9/16	573	34-1/16	865

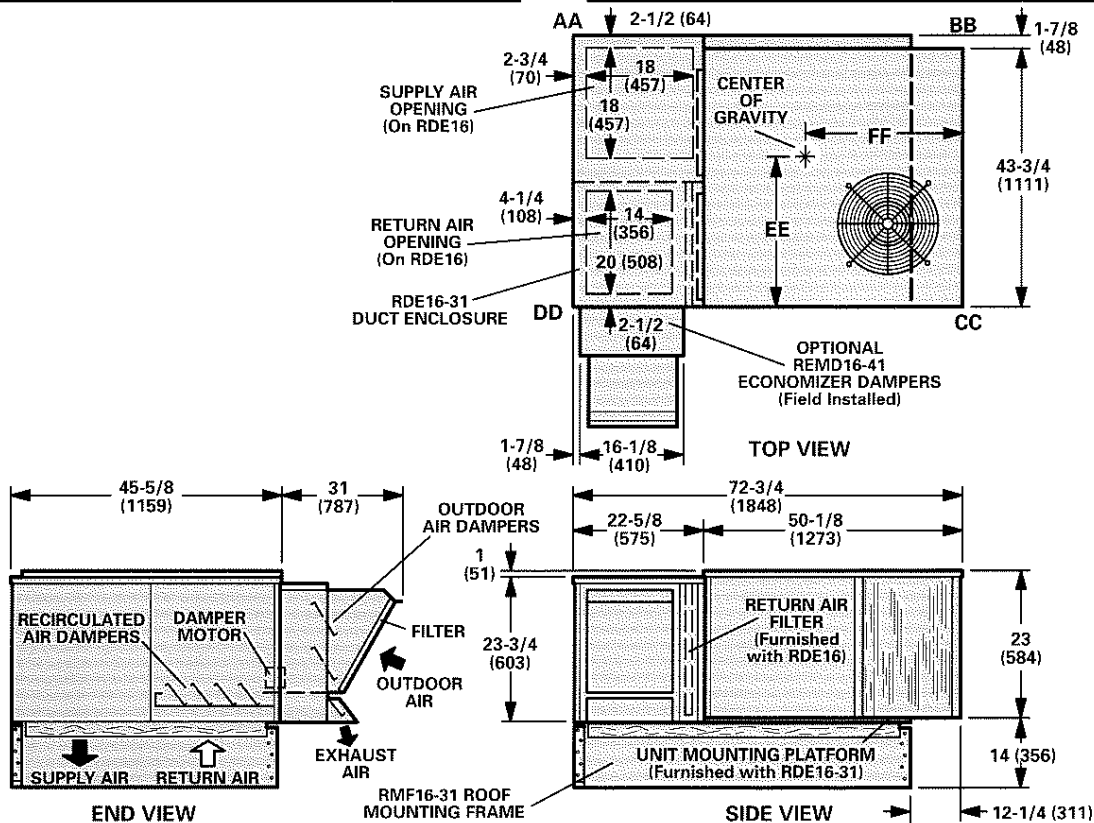

OPTIONAL ACCESSORY DIMENSIONS — inches (mm)

RMF16-31 ROOF MOUNTING FRAME FOR CHP16H-261 UNIT WITH RDE16-31 DUCT ENCLOSURE

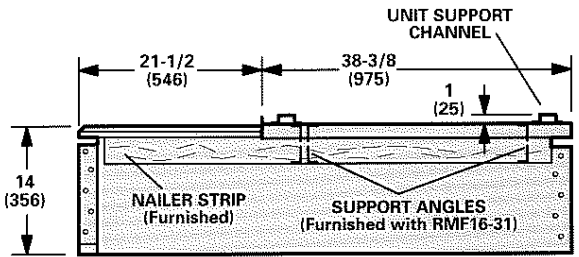
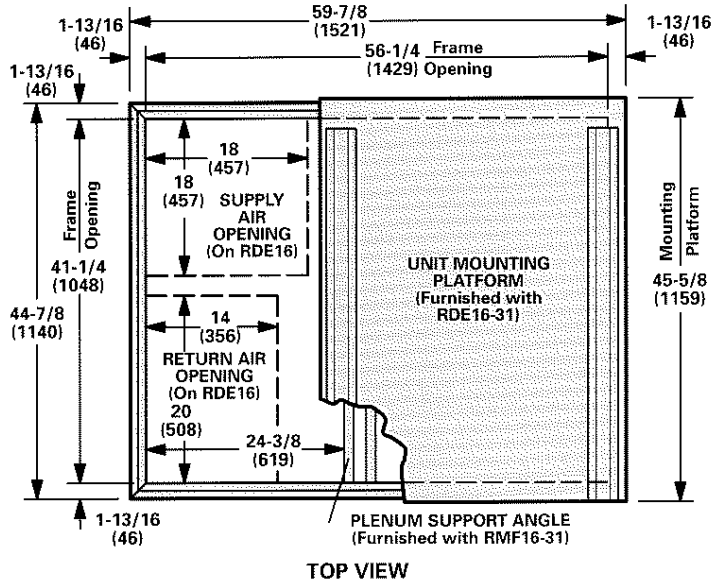

NOTE — Roof deck may be omitted within confines of frame.

SIDE VIEW

RMF16-31 ROOF MOUNTING FRAME FOR CHP16H-261 UNIT WITH SRTH16-65 SUPPLY AND RETURN AIR TRANSITIONS FOR FD9-65 AND RTD9-65 CEILING DIFFUSERS

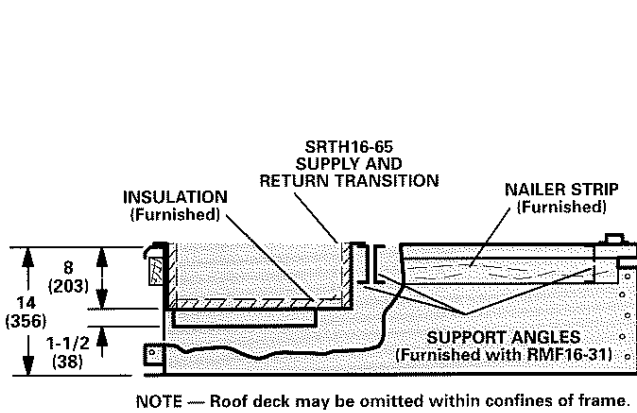

NOTE — Roof deck may be omitted within confines of frame.

SIDE VIEW

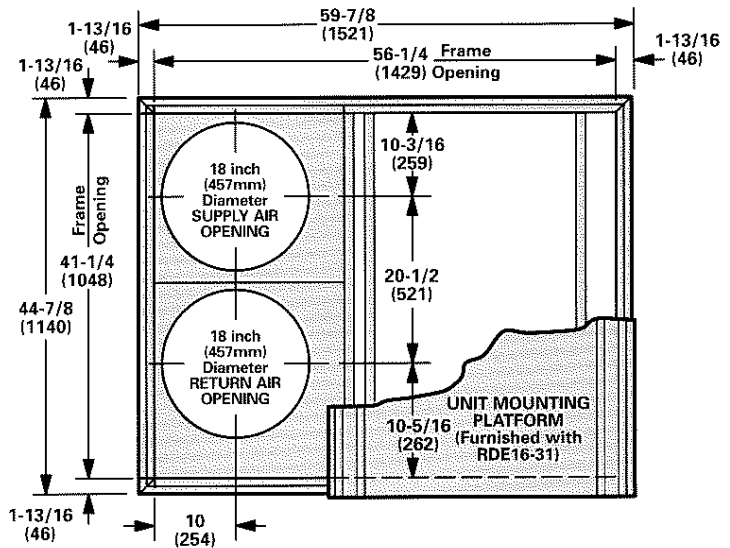

TOP VIEW

TYPICAL FLASHING DETAIL FOR RMF16-31 ROOF MOUNTING FRAME

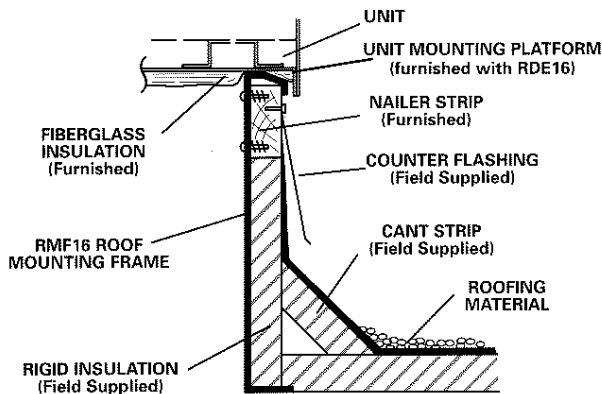

OAD3-46/65 MINIMUM OUTDOOR AIR DAMPER

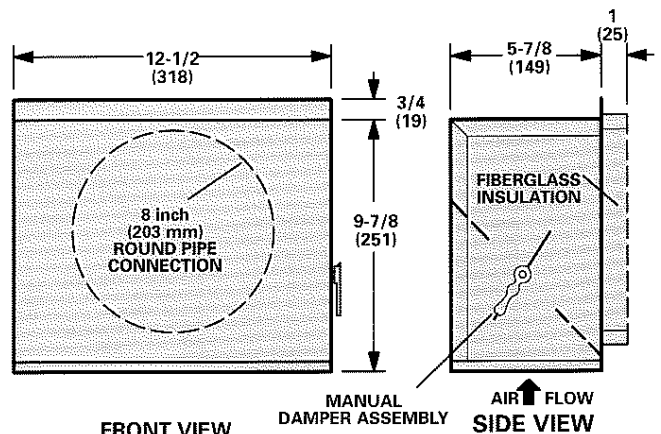

DIMENSIONS — inches (mm)

CHP16-413-513-653 BASIC UNITS

CORNER WEIGHTS

Model Number	AA		BB		CC		DD	
	lbs.	kg	lbs.	kg	lbs.	kg	lbs.	kg
CHP16-413	72	33	77	35	113	51	106	48
CHP16-513	93	42	93	42	142	64	142	64
CHP16-653	102	46	108	49	160	73	151	68

CENTER OF GRAVITY

Model Number	EE		FF	
	inch	mm	inch	mm
CHP16-413	29	737	27-3/8	695
CHP16-513	36-1/4	921	31-7/16	799
CHP16-653	35-1/4	895	31	787

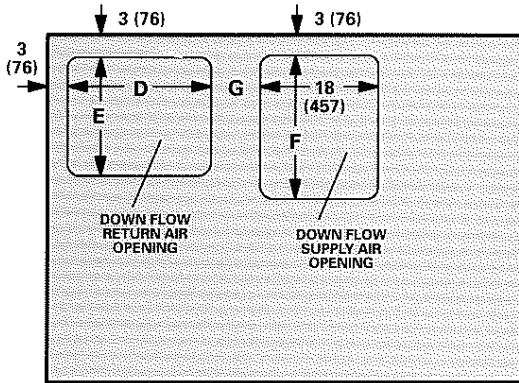

TOP VIEW BASE SECTION

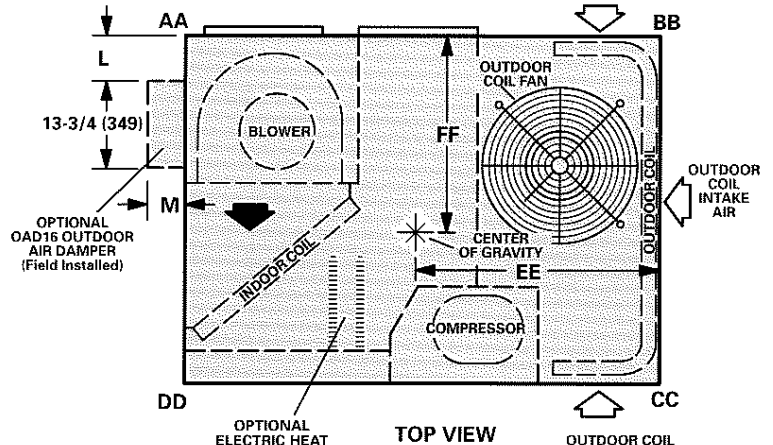

TOP VIEW

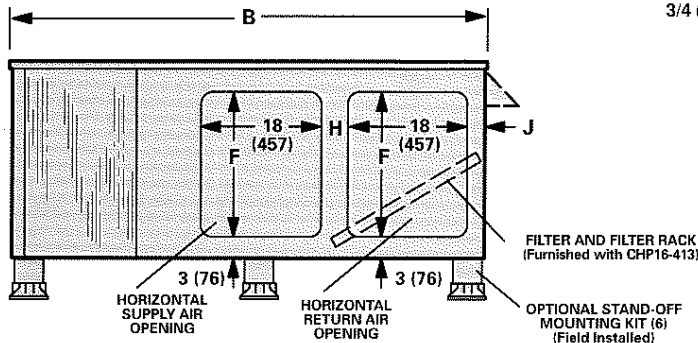

**BACK VIEW
(With Horizontal Supply & Return Air)**

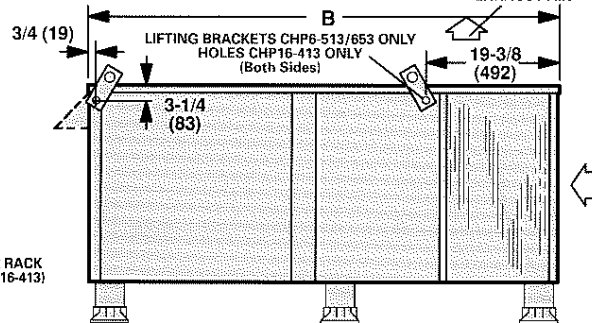

FRONT VIEW

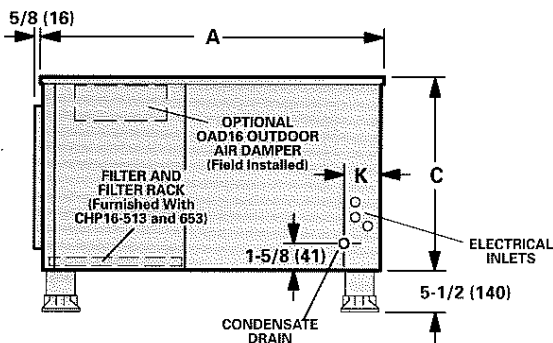

END VIEW

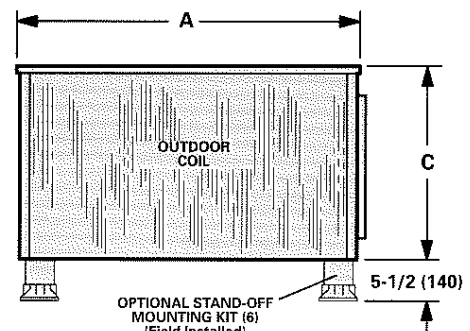

FRONT END VIEW

Model Number	A		B		C		D		E		F		G	
	inch	mm	inch	mm	inch	mm	inch	mm	inch	mm	inch	mm	inch	mm
CHP16-413	46	1168	60	1524	23	584	18	457	13	330	13	330	10	254
CHP16-513	52	1321	72-1/2	1842	29	737	22	559	18	457	22	559	7-1/2	191
CHP16-653														

Model Number	H		J		K		L		M	
	inch	mm	inch	mm	inch	mm	inch	mm	inch	mm
CHP16-413	3	76	4	102	6-1/2	165	2	51	5	127
CHP16-513	5	127	3	76	6-1/8	156	5	127	8	203
CHP16-653										

OPTIONAL ACCESSORY DIMENSIONS — inches (mm)

CHP16-413-513-653 UNITS WITH REMD16M ECONOMIZER DAMPER SECTION AND RMF16 ROOF MOUNTING FRAME

CORNER WEIGHTS

Model Number	AA		BB		CC		DD	
	lbs.	kg	lbs.	kg	lbs.	kg	lbs.	kg
CHP16-413	145	66	124	56	102	46	120	54
CHP16-513	191	87	153	69	124	56	155	70
CHP16-653	200	91	170	77	139	63	164	74

CENTER OF GRAVITY

Model Number	EE		FF	
	inch	mm	inch	mm
CHP16-413	32-5/8	829	20-13/16	529
CHP16-513	40-5/16	1024	23-5/16	592
CHP16-653	39-3/16	995	23-7/16	595

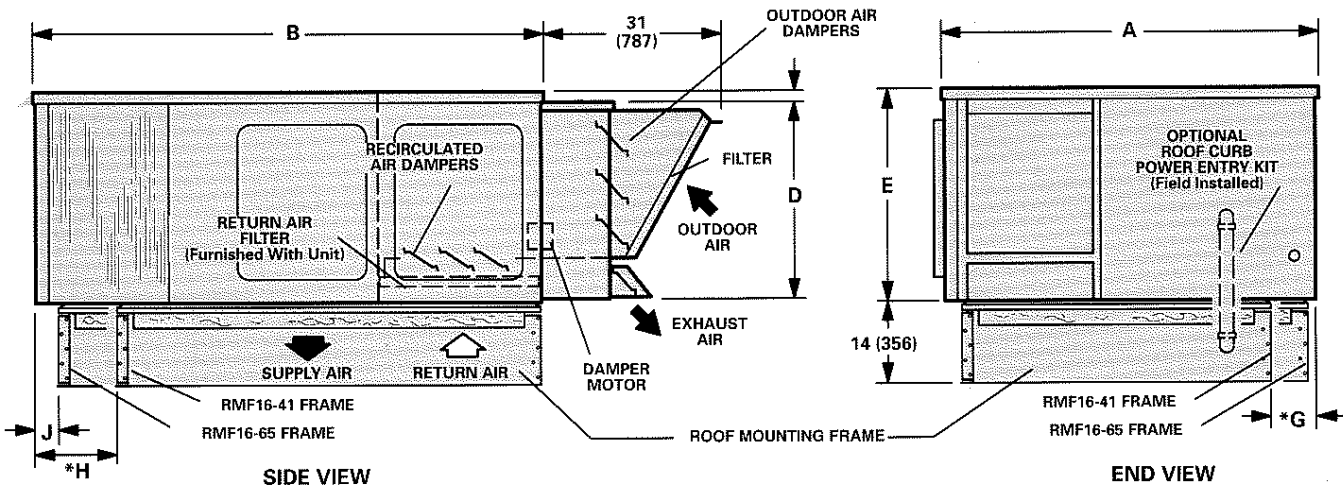
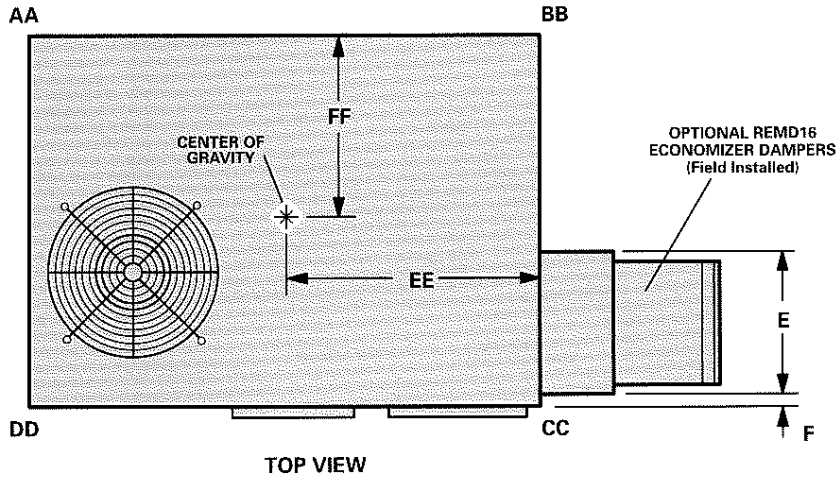

Model Number	A		B		C		D		E		F		*G		*H		J	
	inch	mm	inch	mm	inch	mm	inch	mm	inch	mm	inch	mm	inch	mm	inch	mm	inch	mm
CHP16-413	46	1168	60	1524	23	584	21-3/4	552	16-1/8	410	3/4	19	----	----	----	----	----	----
CHP16-513 CHP16-653	52	1321	72-1/2	1842	29	737	27-3/4	705	20-1/4	514	1-1/2	38	7	178	16	406	3-1/2	89

* Dimensions reflect usage with RMF16-41 mounting frame.

OPTIONAL ACCESSORY DIMENSIONS — inches (mm)

COMBINATION CEILING SUPPLY AND RETURN DIFFUSERS

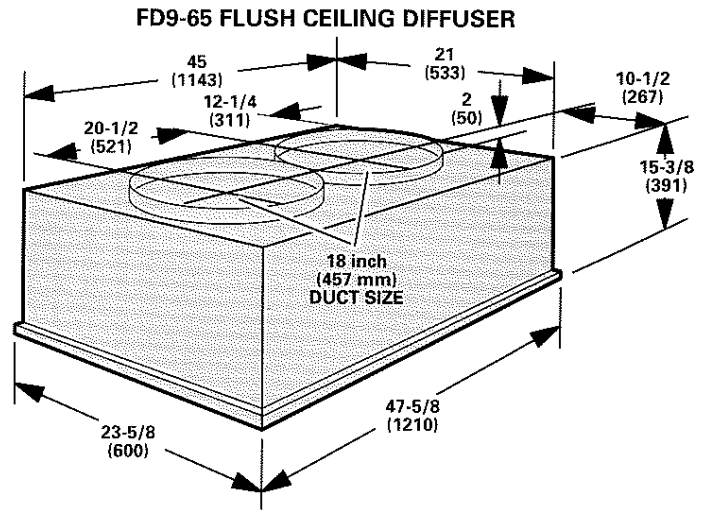
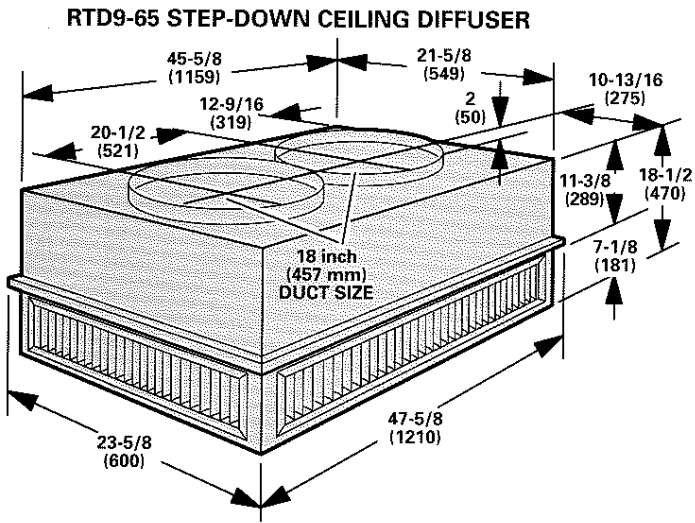

INSTALLATION CLEARANCES — inches (mm)

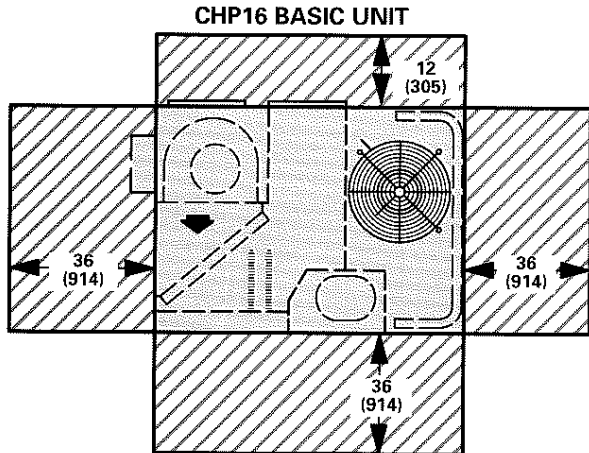

NOTE — Top Clearance Unobstructed.

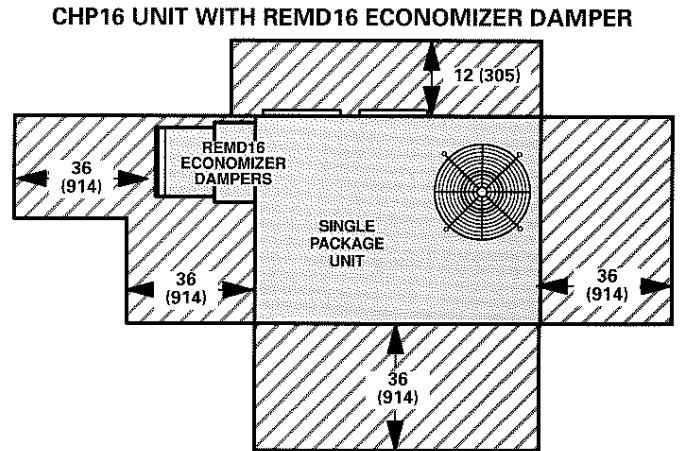

NOTE — Top Clearance Unobstructed.

CHP16 UNIT WITH EMDH16M HORIZONTAL ECONOMIZER AND GEDH16-65 GRAVITY EXHAUST DAMPER

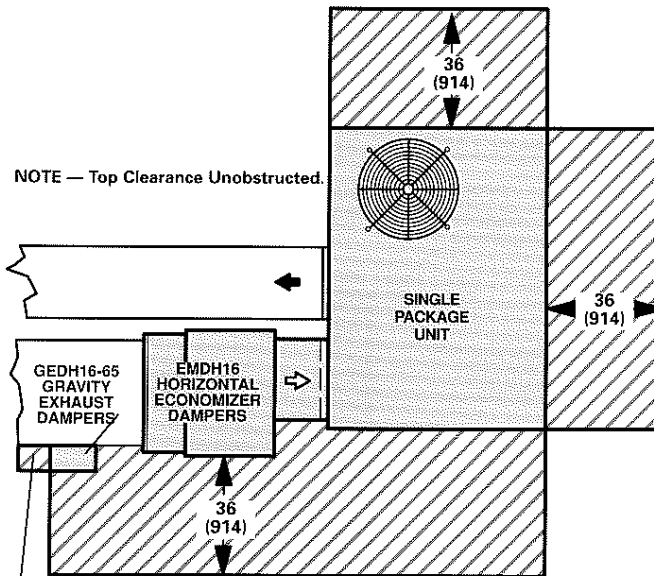

NOTE — Top Clearance Unobstructed.

Allow adequate clearance for duct & GEDH16-65 installation

