

CHP11 SERIES PACKAGED HEAT PUMPS

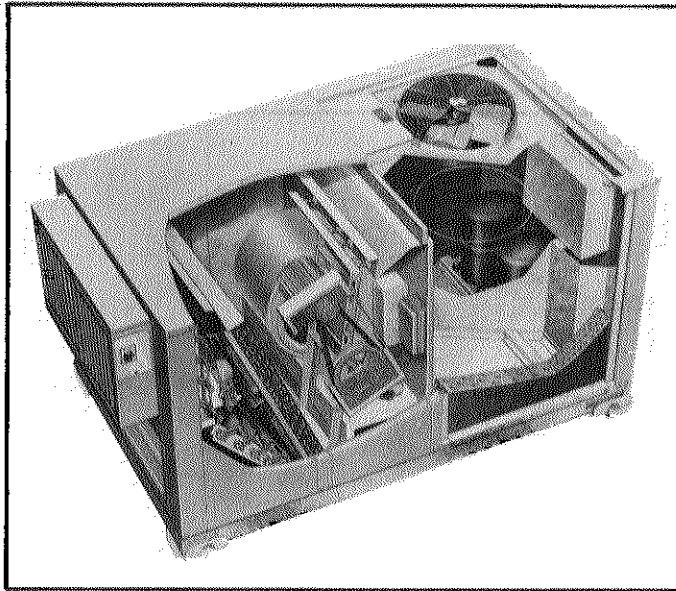

**FIGURE 1
ACCESSORIES - TABLE 1**

Option	Model No.		Availability
	CHP11-953	CHP11-1353	
Hot Water	HWC11-95 (100,000 - 250,000 Btu)	HWC11-135 (100,000 - 275,000 Btu)	Factory Installed Only
Electric Heat	ECH11-95-15 (15KW)	ECH11-135-15 (15KW)	Factory or Field Installed
	ECH11-95-30 (30KW)	ECH11-135-30 (30KW)	
	ECH11-95-45 (45KW)	ECH11-135-45 (45KW)	
	*ECH11-95-60 (60KW)	*ECH11-135-60 (60KW)	

*The ECH11-95-60 and ECH11-135-60 heaters are only used on CHA11-953/1353-W (200V) units. At 200 volts these heaters de-rate to 45 kw.

TABLE 1 (CONT.)

Power Saver	PSD11-95	PSD11-135	Factory or Field Installed
Nite Setback	LB-38134CB	LB-38134CB	Field Installed
Gravity Exhaust Dampers	GED11-95	GED11-135	Field Installed Only
Minimum Fresh Air Dampers (Manual)	OAD11-95	OAD11-135	Field Installed Only
Automatic Fresh Air Damper Kit for OAD11	34C23	34C23	Field Installed Only
Roof Mounting Frame	RMF11-95	RMF11-135	Field Installed Only
Horizontal Mounting Frame	RMFH11-95	RMFH11-135	Field Installed Only
Mounting Frame Adaptor	RMFA11-95	RMFA11-135	Field Installed Only
Ceiling Supply & Return Step-Down Diffuser	RTD11-95	RTD11-135	Field Installed Only
Ceiling Supply & Return Flush Diffuser	FD11-95	FD11-135	Field Installed Only
Ceiling Supply & Return Transitions	SRT11-95	SRT11-135	Field Installed Only
Remote Status Panel	SP11	SP11	Field Installed Only
Remote Switching Status Panel	SSP11	SSP11	Field Installed Only
Disconnect Mounting Kit	LB-38208BA	LB-38208BA	Field Installed Only

TABLE OF CONTENTS

I - INTRODUCTION	Page 2
CHP11 Control Option Chart	Page 2
II - UNIT INFORMATION	
Specifications — Electrical Data	Page 3
Dimensions — Installation Clearances	Page 4
Blower Performance Chart	Page 5
Pressure Curves	Page 6
Heating Performance Chart — RFM11 Roof Mounting Frame	Page 9
Combination Ceiling Supply & Return	Page 10
RMFH11 Horizontal Mounting Frame	Page 11
RMFA11 Adaptor Frame — Power Supply Field Wiring	Page 12
Low Voltage Field Wiring	Page 13
III - REFRIGERANT SYSTEM	Page 16
IV - CHP11 COMPONENTS	
Main Control Box — Make-up Box	Page 18
Compressor Compartment — Blower Compartment	Page 19
Component Index	Page 20
V - BLOWER OPERATION AND ADJUSTMENTS	Page 22
VI - THERMOSTAT OR TRANSMITTER OPERATION	Page 22
VII - CHP11 UNIT OPTIONS	
Power Saver	Page 23
Fresh Air Dampers — Electric Heat	Page 25
Hot Water	Page 26
Night Setback	Page 28
VIII - STATUS PANEL OPTIONS	Page 29
IX - FIRESTATS	Page 30
X - MAINTENANCE	Page 30
XI - GENERAL SCHEMATIC INFORMATION	Page 31
Unit Diagrams	Page 30
XII - OPERATING SEQUENCE	
Cooling Mode	Page 38
Heating Mode	Page 40
Defrost Cycle	Page 42
Emergency Heat	Page 43
XIII - TROUBLESHOOTING	Page 44

I - INTRODUCTION

CHP11 production is scheduled in 1980 for the 7-1/2 and 10 ton models. Figure 1 shows a cutaway of unit. Auxiliary heat (electric or hot water) is available for these rooftop heat pumps. Other options are listed in Table 1.

Units are designed for rooftop installation with either bottom or horizontal discharge. The RMF11 roof mounting frame mates to the bottom of unit. The added installation of a

RMFH11 mounting frame permits horizontal discharge. The RMFA11 mounting frame adaptor allows unit installation on an existing RMF3 roof mounting frame in retrofit applications.

The CHP11 incorporates the "Honeywell Single Zone Solid State Control System." Figure 2 illustrates the compatible control options and lists the corresponding ordering numbers.

CHP11 CONTROL OPTION CHART

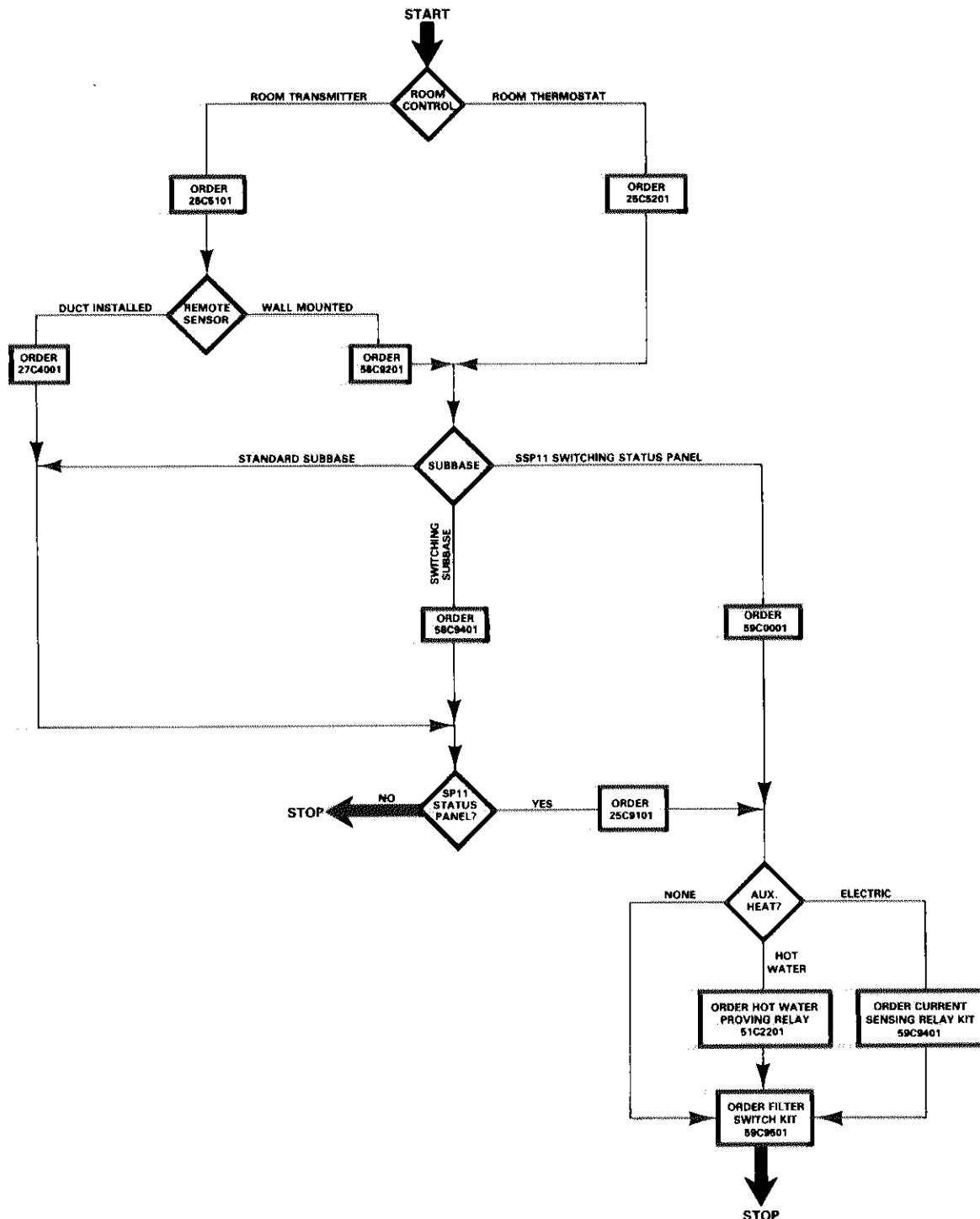

FIGURE 2

II - UNIT INFORMATION

A - Specifications

Model No.		CHP11-953	CHP11-1353
★ARI Standard 270 SRN		21	22
*ARI Certified Cooling Capacity	Cooling Capacity (Btuh)	89,000	122,000
	Total unit watts cooling	11,300	15,200
	†EER (Btuh Watts)	7.9	8.0
	Dehumidifying capacity	27%	29%
*ARI Certified High Temperature Heating Capacity	Total capacity (Btuh)	89,000	125,000
	Total unit watts	9300	12,600
	C.O.P.	2.8	2.9
*ARI Certified Low Temperature Heating Capacity	Total capacity (Btuh)	43,000	64,000
	Total unit watts	7000	10,400
	C.O.P.	1.8	1.8
Refrigerant charge (R-22)		20 lbs. 5 oz.	26 lbs.
Indoor Coil	Net face area (sq. ft.)	8.3	12.0
	Tube diameter (in.) & No. of rows	1/2 — 4	1/2 — 4
	Fins per inch	15	15
Indoor Coil Blower	Wheel nominal diam. x width (in.)	(1) 15 x 9	(1) 15 x 15
	Motor horsepower (Minimum-Maximum)	1-1/2 — 3	3 — 5
Outdoor Coil	Net face area (sq. ft.)	14.8	19.9
	Tube diameter (in.) & No. of rows	1/2 — 3	1/2 — 3
	Fins per inch	15	15
Outdoor Coil Fans	Diameter (in.) and No. of blades	(2) 20 — 4	(2) 24 — 4
	Air Volume (factory setting)	6000	8500
	Rpm (factory setting)	1075	1075
	Motor horsepower	(2) 1/3	(2) 1/2
	Motor watts (factory setting)	850	1200
Optional Hot Water Coil	Model No. & Net Weight	HWC11-95 (65 lbs.)	HWC11-135 (75 lbs.)
	**Heating capacity range (Btuh)	100,000 — 250,000	100,000 — 275,000
	Net face area (sq. ft.)	4.5	6.5
	Tube diameter (in.) — No. of rows	1/2 — 2	1/2 — 2
	Fins per inch	16	10

†Energy Efficiency Ratio in accordance with ARI Standard 240.

★Sound Rating Number in accordance with ARI Standard 270.

*Rated in accordance with ARI Standard 240: At 450 cfm (maximum) indoor air volume per ton of cooling capacity.

Cooling Ratings — 95F outdoor air temperature and 80F db 67F wb entering indoor coil air.

High Temperature Heating Ratings — 47F db 15F wb outdoor air temperature and 70F db entering indoor coil air.

Low Temperature Heating Ratings — 17F db 15F wb outdoor air temperature and 70F db entering indoor coil air.

**Capacity range shown is possible with varying supply conditions and air volumes. See Figure 23

B - Electrical Data

Model No.		CHP11-953								CHP11-1353							
Line voltage data — 60 hz — 3 phase		200V		230V		460V		575V		200V		230V		460V		575V	
Compressors (2)	Rated load amps (total)	30.6	28.2	16.0	11.2	39.0	39.0	20.0	15.0	39.0	39.0	20.0	15.0	39.0	39.0	20.0	15.0
	Locked rotor amps (total)	148.0	148.0	74.0	72.0	264.0	264.0	132.0	112.0	264.0	264.0	132.0	112.0	264.0	264.0	132.0	112.0
Outdoor Coil Fan Motors (2)	Full load amps (total)	4.6	4.2	2.2	1.6	6.0	6.0	3.0	2.4	6.0	6.0	3.0	2.4	6.0	6.0	3.0	2.4
	Locked rotor amps (total)	9.4	9.4	4.6	4.0	12.4	12.4	6.2	5.8	12.4	12.4	6.2	5.8	12.4	12.4	6.2	5.8
Indoor Coil Blower Motor	Horsepower	1-1/2	3	1-1/2	3	1-1/2	3	1-1/2	3	3	5	3	5	3	5	3	5
	Full load amps	6.0	11.0	5.2	9.6	2.6	4.8	2.1	3.9	11.0	17.5	9.6	15.2	4.8	7.6	3.9	6.1
	Locked rotor amps	39.0	65.0	34.0	56.0	17.0	28.0	15.0	25.6	65.0	100.0	56.0	90.0	28.0	45.0	25.6	35.0
Recommended maximum fuse size (amps)		50	60	50	50	30	30	20	20	70	80	70	70	40	40	30	30
Unit Power Factor		.89	.88	.89	.88	.89	.88	.89	.88	.89	.88	.89	.88	.89	.88	.89	.88
*Minimum Circuit Ampacity		45.0	50.0	41.1	45.5	22.8	25.0	16.4	18.1	60.9	67.4	59.5	65.1	30.3	33.1	23.2	25.4

*Refer to Miscellaneous Engineering Data page 9 or National Electric Code manual to determine wire, fuse and disconnect size requirements.
NOTE — Extremes of operating range are plus and minus 10% of line voltage.

C - Dimensions

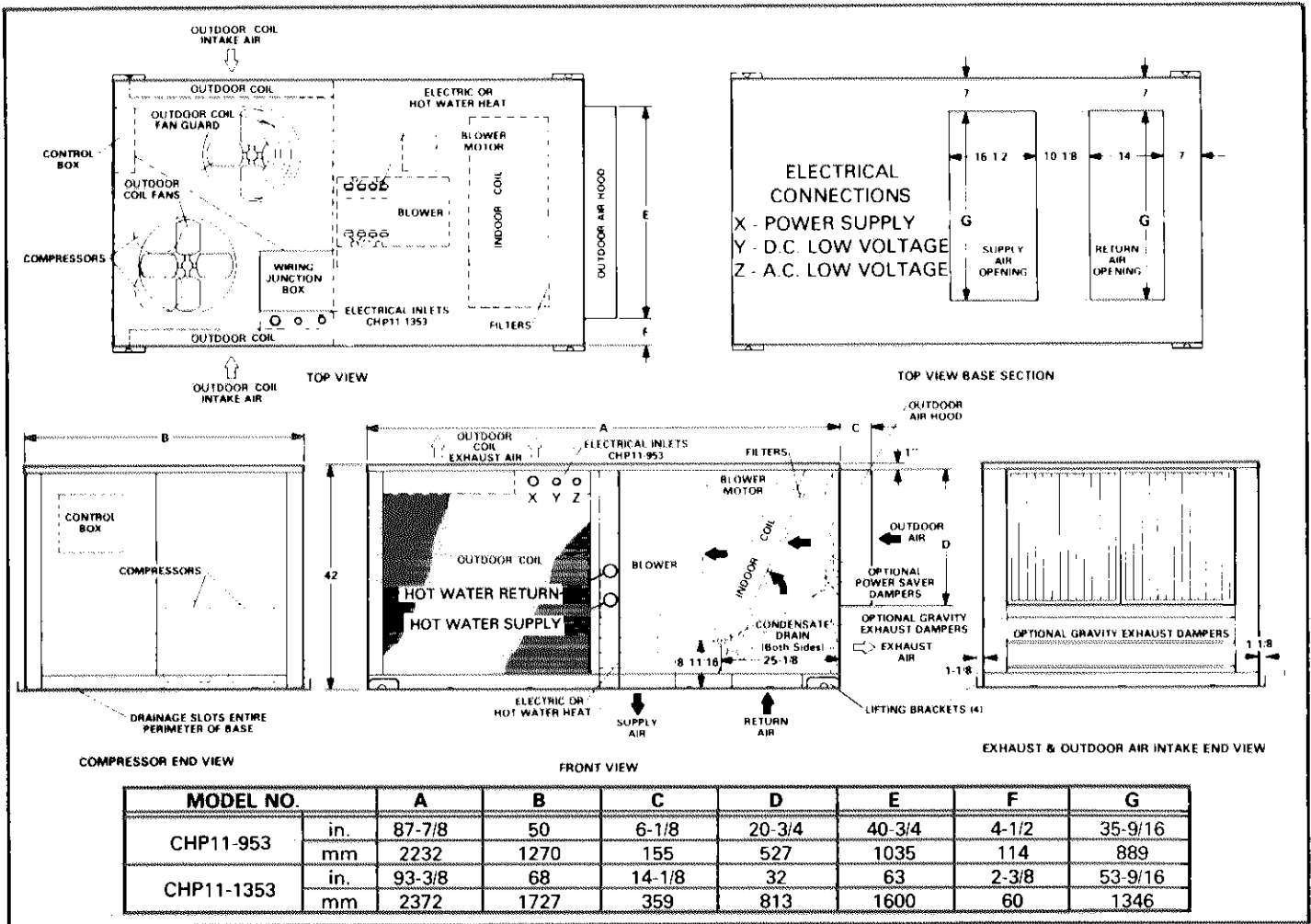

MODEL NO.		A	B	C	D	E	F	G
CHP11-953	in.	87-7/8	50	6-1/8	20-3/4	40-3/4	4-1/2	35-9/16
	mm	2232	1270	155	527	1035	114	889
CHP11-1353	in.	93-3/8	68	14-1/8	32	63	2-3/8	53-9/16
	mm	2372	1727	359	813	1600	60	1346

D - Installation Clearances

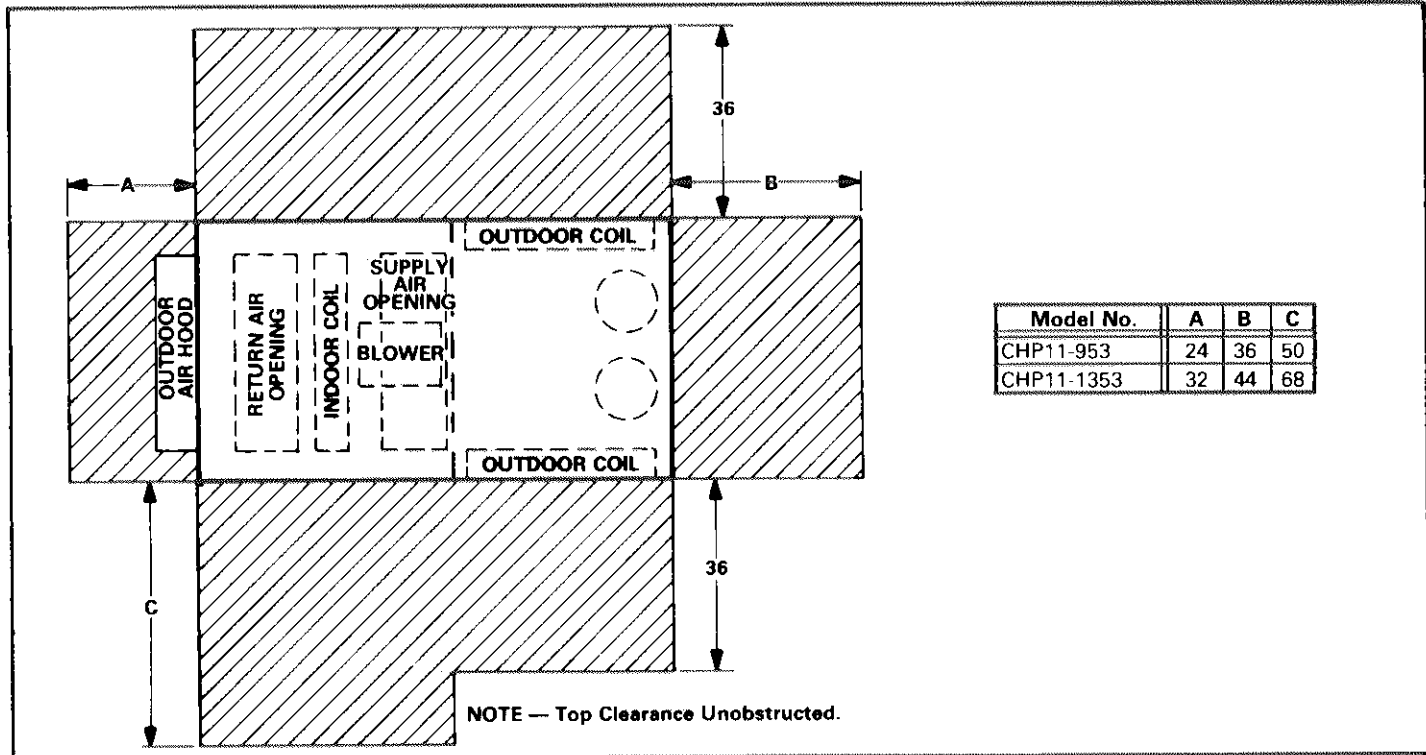

Model No.	A	B	C
CHP11-953	24	36	50
CHP11-1353	32	44	68

E - Blower Performance

LESS ELECTRIC HEAT																						
Air Volume (Cfm)	STATIC PRESSURE EXTERNAL TO UNIT (Return Air System) — (Inches Water Gauge)																					
	0		.10		.20		.30		.40		.50		.60		.70		.80		.90		1.00	
	RPM	BHP	RPM	BHP	RPM	BHP	RPM	BHP	RPM	BHP	RPM	BHP	RPM	BHP	RPM	BHP	RPM	BHP	RPM	BHP	RPM	BHP
CHP11-953																						
3000	670	1.00	705	1.15	740	1.35	775	1.50	810	1.65	840	1.8	870	1.95	905	2.1	930	2.3	950	2.4	975	2.55
3200	710	1.25	745	1.35	780	1.60	820	1.75	845	1.85	875	2.0	910	2.2	935	2.4	960	2.55	985	2.7	1012	2.9
3400	750	1.50	785	1.65	825	1.85	855	2.05	885	2.2	920	2.35	945	2.55	970	2.75	995	2.9	1020	3.1	----	----
3600	790	1.75	830	1.95	860	2.15	895	2.3	925	2.5	950	2.7	975	2.9	1010	3.1	----	----	----	----	----	----
3800	835	2.1	870	2.25	905	2.45	935	2.7	960	2.9	985	3.05	1020	3.3	----	----	----	----	----	----	----	----
CHP11-1353																						
4000	520	.75	560	.95	605	1.15	640	1.35	665	1.45	705	1.55	730	1.7	770	1.85	800	2.0	825	2.15	855	2.3
4200	545	.90	580	1.10	625	1.30	660	1.45	685	1.65	720	1.7	750	1.9	780	2.05	815	2.2	840	2.35	870	2.5
4400	575	1.1	610	1.25	645	1.50	670	1.65	700	1.75	735	1.9	770	2.1	800	2.3	825	2.4	860	2.6	885	2.8
4600	600	1.25	635	1.50	665	1.70	685	1.8	720	1.95	755	2.15	780	2.3	815	2.45	840	2.65	875	2.85	905	3.05
4800	630	1.50	655	1.70	670	1.8	705	1.95	740	2.15	770	2.35	805	2.55	830	2.75	865	2.95	890	3.15	920	3.25
5000	660	1.75	665	1.85	685	1.9	720	2.15	760	2.4	780	2.6	820	2.8	850	3.0	875	3.2	910	3.35	935	3.55
5200	665	1.90	675	2.0	710	2.2	740	2.4	775	2.6	810	2.85	840	3.1	870	3.3	895	3.45	925	3.65	955	3.85
5400	675	2.10	690	2.2	730	2.4	765	2.6	790	2.85	825	3.15	860	3.4	880	3.55	915	3.75	940	3.95	975	4.3
5600	685	2.2	715	2.35	750	2.65	780	2.85	820	3.15	845	3.45	875	3.65	905	3.85	930	4.05	965	4.3	985	4.45

WITH ELECTRIC HEAT																						
Air Volume (Cfm)	STATIC PRESSURE EXTERNAL TO UNIT (Return Air System) — (Inches Water Gauge)																					
	0		.10		.20		.30		.40		.50		.60		.70		.80		.90		1.00	
	RPM	BHP	RPM	BHP	RPM	BHP	RPM	BHP	RPM	BHP	RPM	BHP	RPM	BHP	RPM	BHP	RPM	BHP	RPM	BHP	RPM	BHP
CHP11-953																						
3000	875	1.6	910	1.8	945	1.95	975	2.1	1015	2.3	1040	2.45	1070	2.6	1100	2.8	1125	2.95	1150	3.05	1175	3.25
3200	930	2.0	970	2.2	1000	2.3	1030	2.5	1060	2.65	1090	2.85	1120	3.0	1145	3.15	1170	3.3	----	----	----	----
3400	990	2.35	1025	2.55	1055	2.75	1085	2.9	1120	3.1	1145	3.3	1170	3.45	----	----	----	----	----	----	----	----
3600	1050	2.8	1080	3.0	1115	3.15	1140	3.4	----	----	----	----	----	----	----	----	----	----	----	----	----	----
3800	1115	3.3	----	----	----	----	----	----	----	----	----	----	----	----	----	----	----	----	----	----	----	----
CHP11-1353																						
4000	740	1.75	780	1.9	820	2.15	850	2.3	875	2.4	910	2.55	940	2.7	970	2.9	990	3.0	1020	3.2	1035	3.35
4200	780	2.1	820	2.25	850	2.4	875	2.5	915	2.7	940	2.85	975	3.1	1000	3.2	1020	3.4	1040	3.55	1070	3.75
4400	820	2.35	850	2.5	880	2.65	915	2.8	950	3.05	975	3.2	1010	3.45	1025	3.6	1050	3.8	1075	3.95	----	----
4600	855	2.6	880	2.75	920	3.0	955	3.25	980	3.4	1015	3.65	1030	3.8	1060	4.05	1080	4.25	----	----	----	----
4800	885	2.9	925	3.15	960	3.4	985	3.55	1015	3.8	1035	4.0	1065	4.25	1080	4.4	----	----	----	----	----	----
5000	930	3.35	965	3.6	990	3.75	1020	4.0	1040	4.2	1070	4.45	1095	4.7	----	----	----	----	----	----	----	----
5200	970	3.75	1000	4.0	1025	4.2	1050	4.45	1075	4.65	----	----	----	----	----	----	----	----	----	----	----	----
5400	1010	4.2	1030	4.4	1060	4.7	1080	4.95	----	----	----	----	----	----	----	----	----	----	----	----	----	----
5600	1030	4.55	1065	4.9	1090	5.2	----	----	----	----	----	----	----	----	----	----	----	----	----	----	----	----

CHP11-953 CFM RANGE 3000-3800
 CHP11-1353 CFM RANGE 4000-5600

F - Pressure Curves

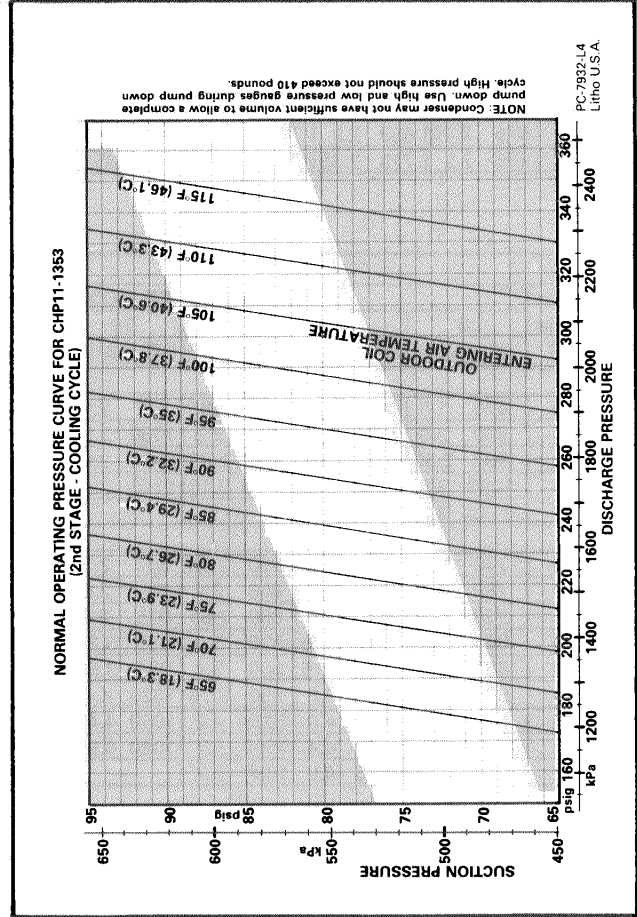
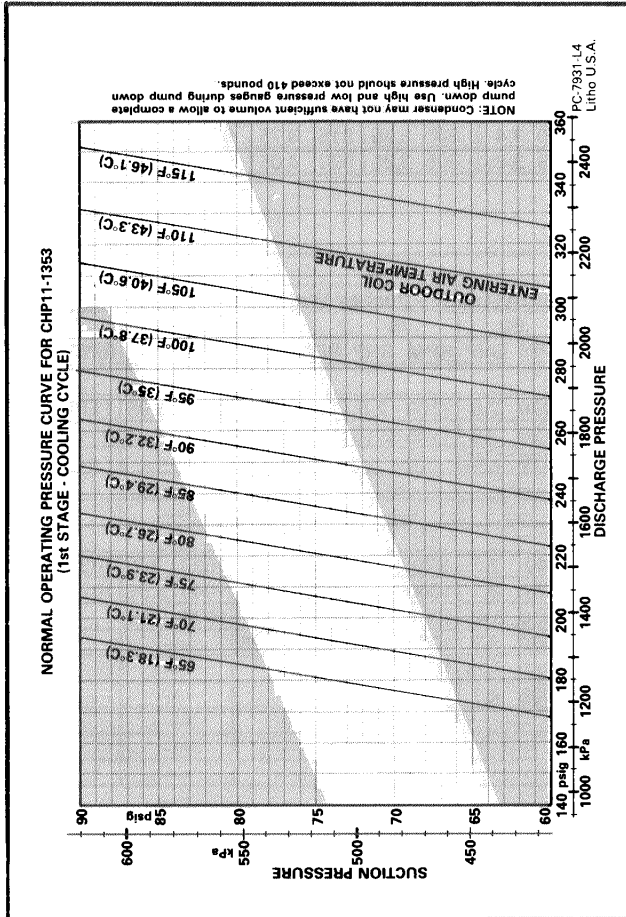
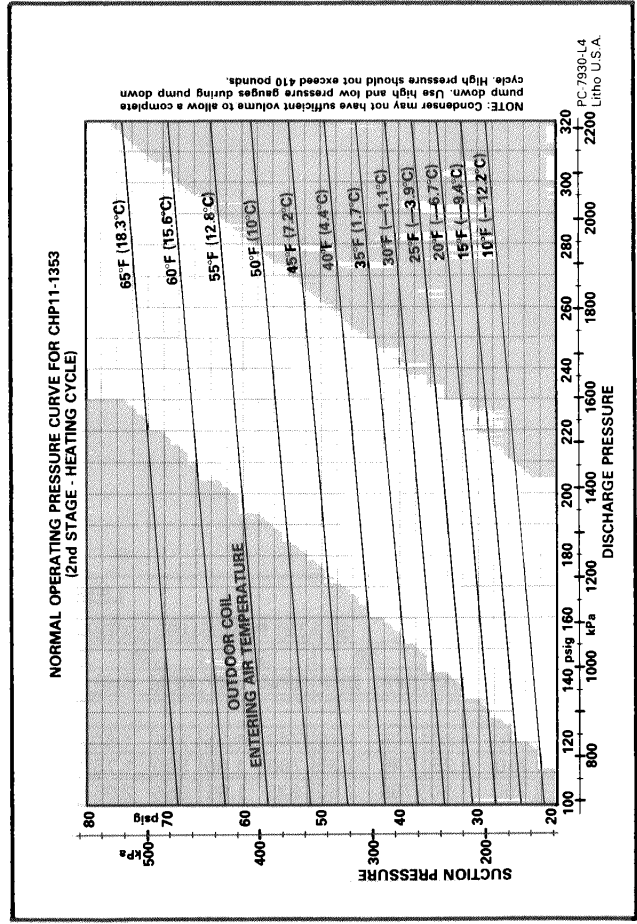
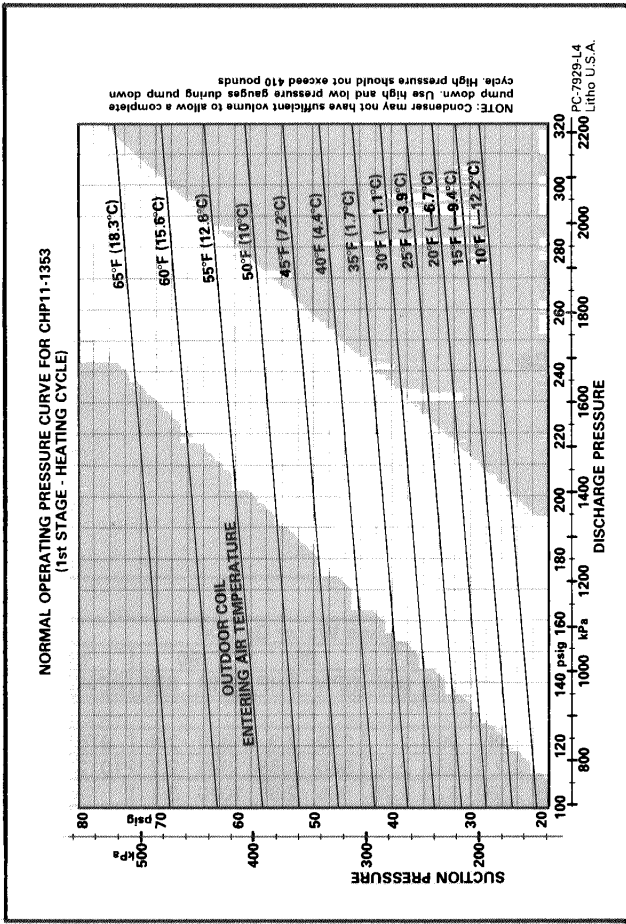

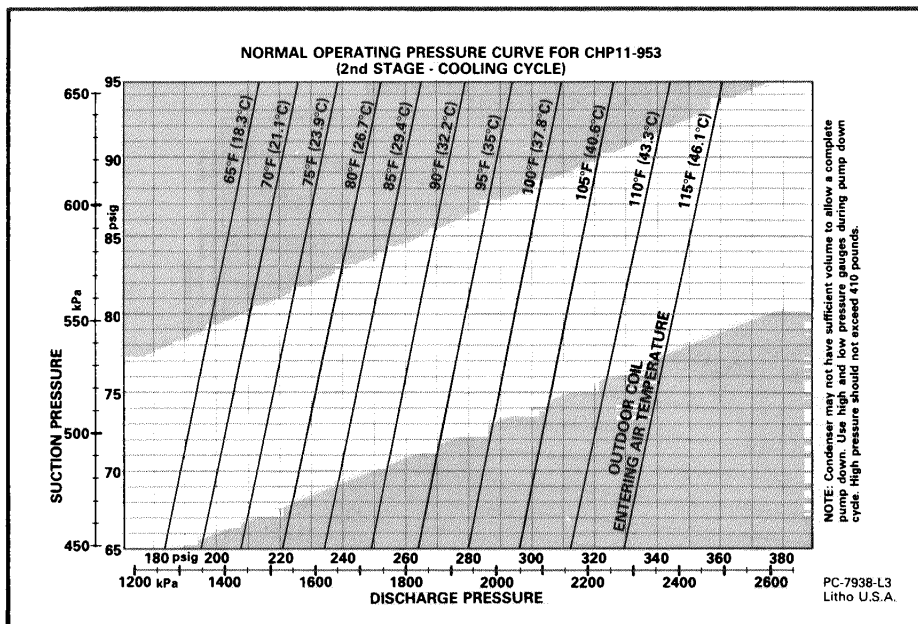
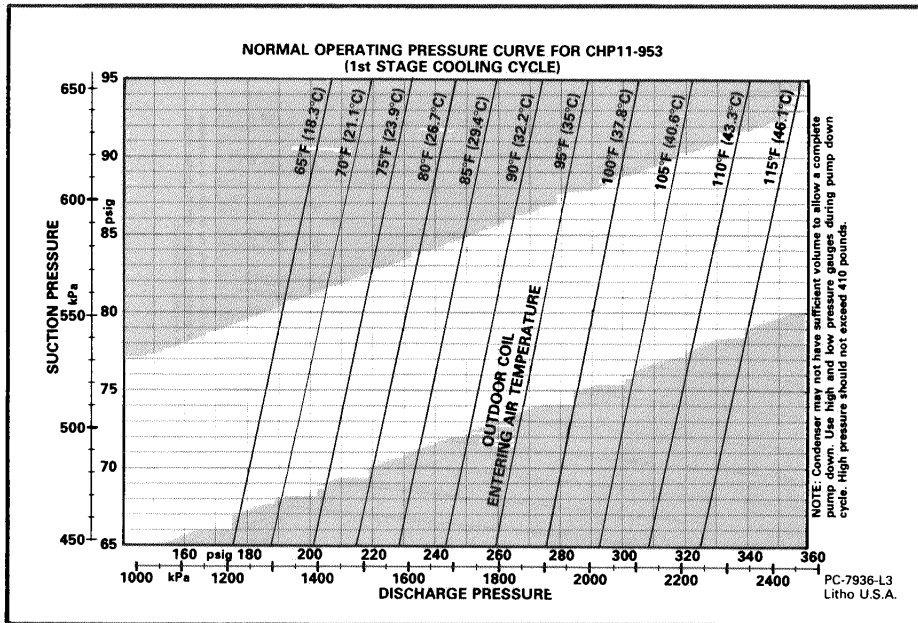

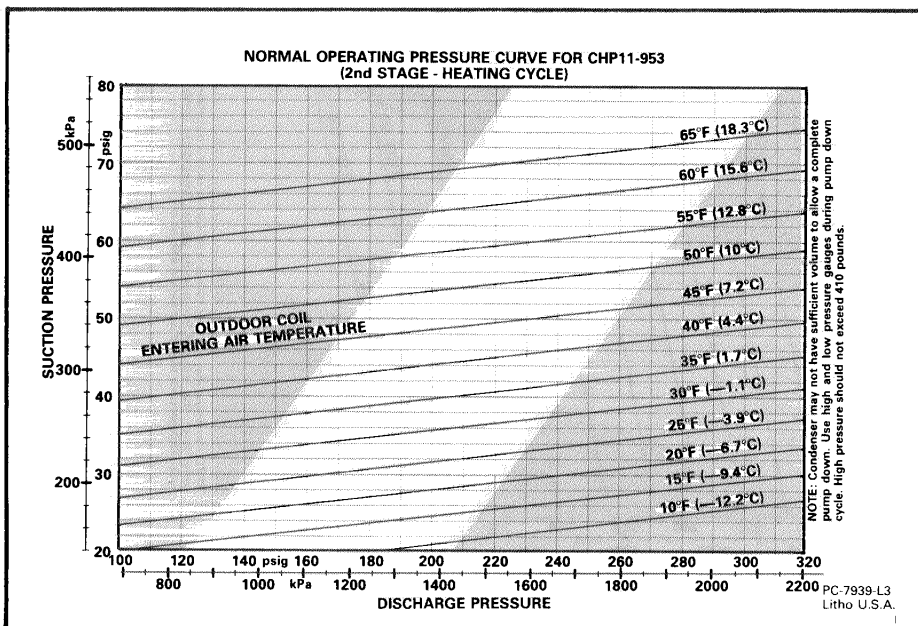
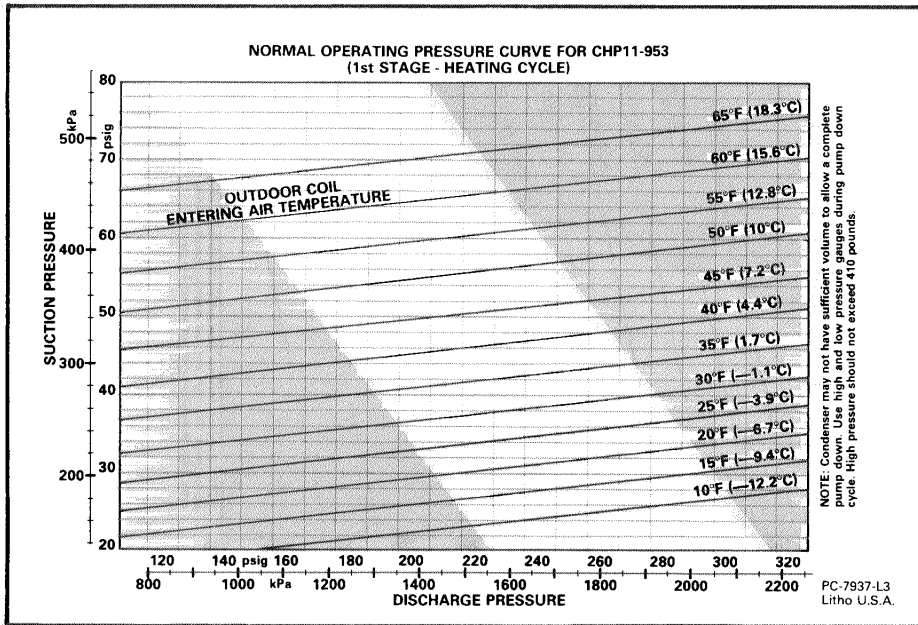

G - Heating Performance Charts

CHP11-953 HEATING PERFORMANCE
at 3375 CFM Indoor Coil Air Volume

CHP11-1353 HEATING PERFORMANCE
at 4500 CFM Indoor Coil Air Volume

*Outdoor Temperature (Degrees F)	Compressor Motor Watts Input	Total Output (Btuh)
First Stage Only		
65	4170	59,200
60	3990	55,900
55	3810	52,800
50	3630	49,600
45	3450	46,300
40	3260	38,700
35	3090	35,400
30	2900	32,000
Both Stages On		
65	8330	113,500
60	7980	107,000
55	7610	100,700
50	7250	94,300
45	6890	87,800
40	6520	72,500
35	6170	65,900
30	5800	59,200
25	5440	53,000
20	5070	47,100
15	4700	41,800
10	4410	37,700
5	4160	34,200
0	3910	31,100
-5	3710	27,400
-10	3520	25,900
-15	3320	23,500
-20	3150	21,300

*Outdoor Temperature (Degrees F)	Compressor Motor Watts Input	Total Output (Btuh)
First Stage Only		
65	5690	80,900
60	5480	76,700
55	5260	72,600
50	5050	68,500
45	4830	64,400
40	4630	54,600
35	4430	49,100
30	4250	45,000
Both Stages On		
65	11,370	156,500
60	10,950	148,200
55	10,620	139,900
50	10,100	131,700
45	9660	123,500
40	9250	101,900
35	8860	93,000
30	8600	84,800
25	8130	76,800
20	7780	69,500
15	7430	63,000
10	7100	57,600
5	6760	52,200
0	6440	47,900
-5	6120	43,900
-10	5850	39,800
-15	5580	36,300
-20	5330	32,400

*Outdoor temperature at 70% relative humidity. Indoor temperature at 70°.

*Outdoor temperature at 70% relative humidity. Indoor temperature at 70°.

H - RMF11 Roof Mounting Frame

DOUBLE DUCT APPLICATION

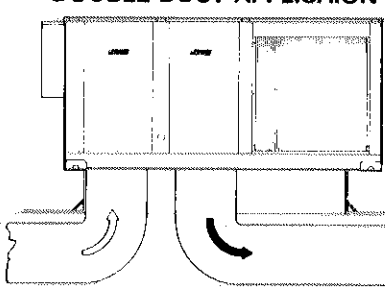

RMF11 ROOF MOUNTING FRAME WITH DOUBLE DUCT OPENING

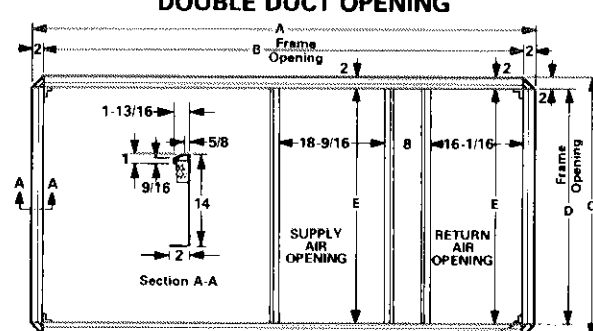

CORNER ANGLE
(4 furnished for frame assembly)

RECOMMENDED FLASHING FOR RMF11 ROOF MOUNTING FRAME

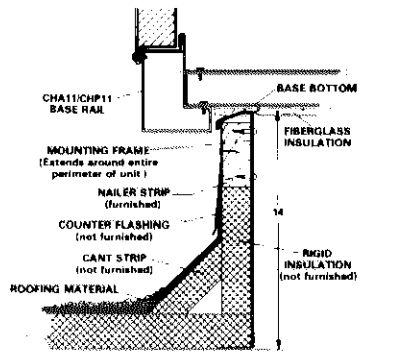

2" X 4" NAILER STRIP (furnished)

NOTE - Roof deck may be omitted within the confines of frame.

Model No.	A	B	C	D	E
RMF11-95	79 $\frac{1}{8}$ "	75 $\frac{1}{8}$ "	41 $\frac{1}{8}$ "	37 $\frac{1}{8}$ "	37 $\frac{1}{8}$ "
RMF11-135	85 $\frac{1}{8}$ "	81 $\frac{1}{8}$ "	59 $\frac{1}{8}$ "	55 $\frac{1}{8}$ "	55 $\frac{1}{8}$ "

I - RMF11 With Combination Ceiling Supply And Return

CHA11-953

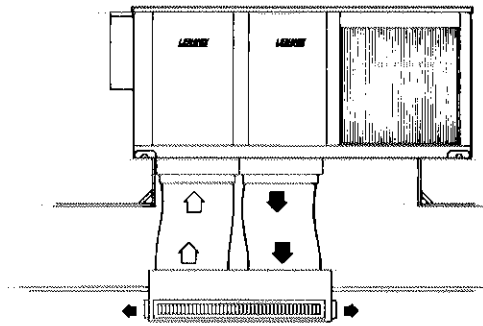

CHA11-1353

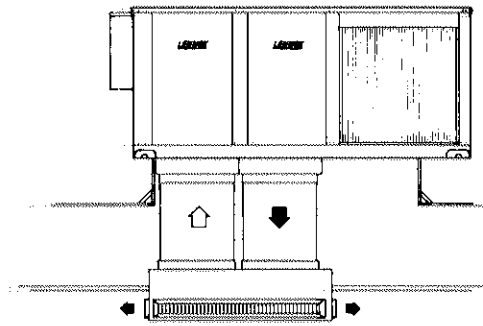

RMF11 WITH SRT11-95 TRANSITIONS

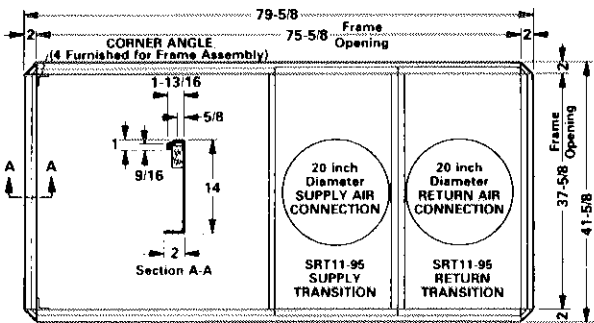

RMF11 WITH SRT11-135 TRANSITIONS

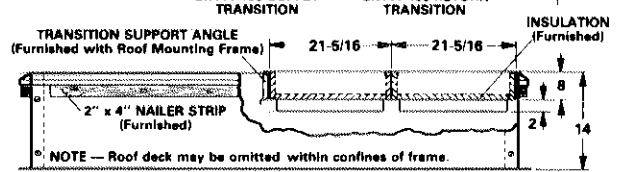
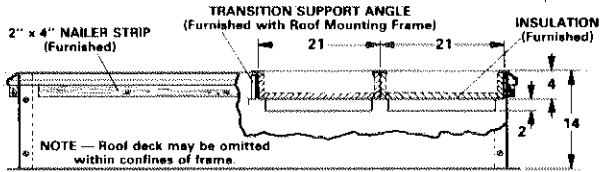
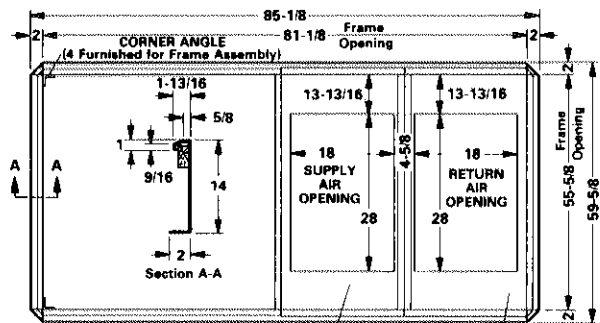

RTD11-95 STEP-DOWN DIFFUSER

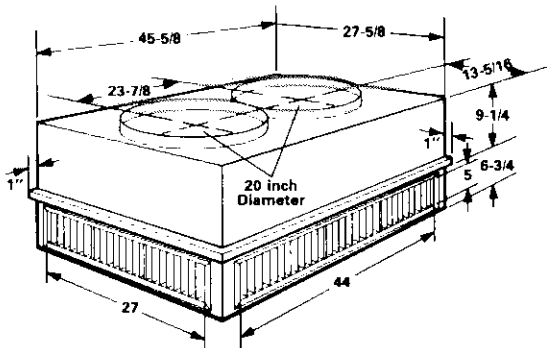

RTD11-135 STEP-DOWN DIFFUSER

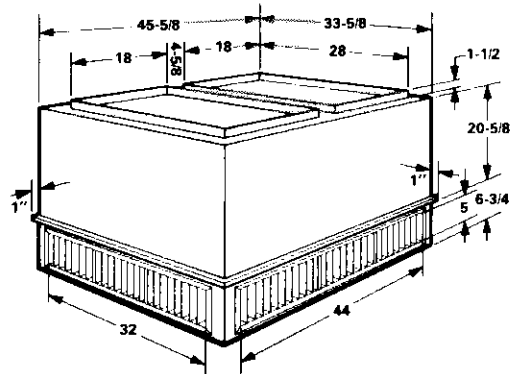

FTD11-95 FLUSH DIFFUSER

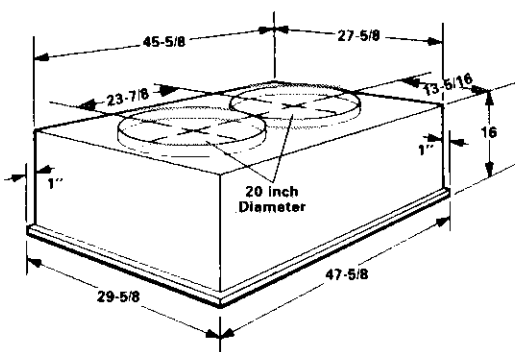

FTD11-135 FLUSH DIFFUSER

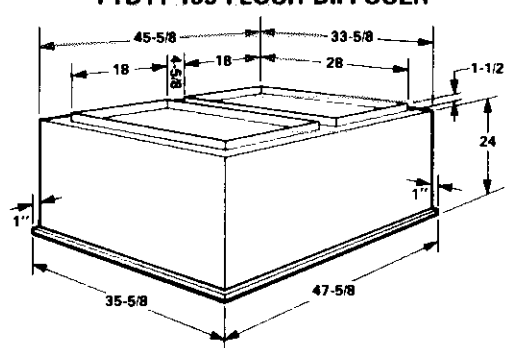

J - RMFH11 Horizontal Mounting Frame

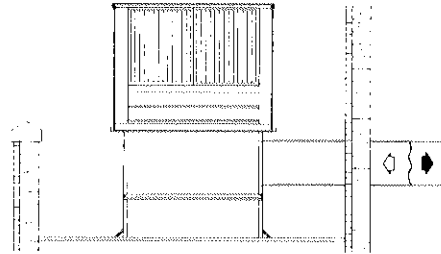

RMFH11 HORIZONTAL MOUNTING FRAME WITH RMF11

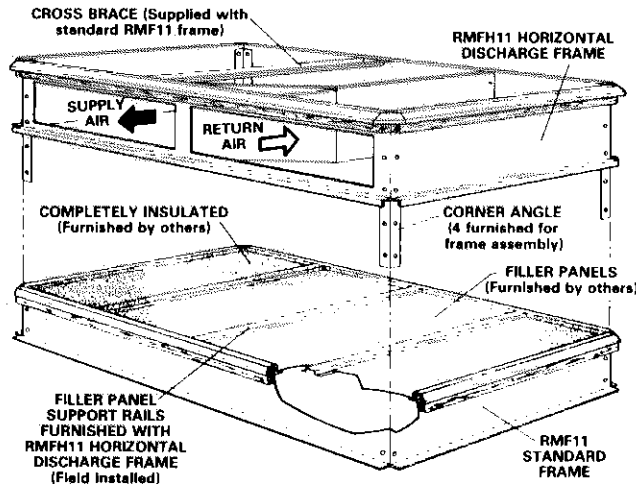

NOTE — See Installation Instruction for recommended size and location of filler panels.

RMFH11 AND RMF11 FRAME MOUNTING DETAIL

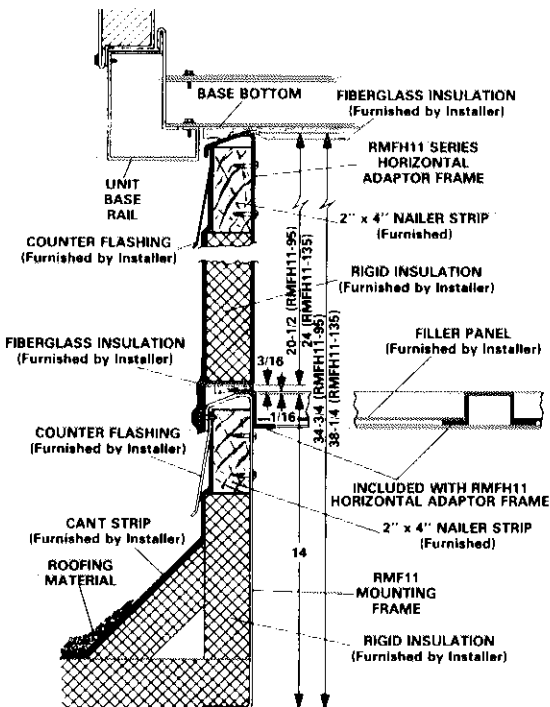

RMFH11 HORIZONTAL MOUNTING FRAME

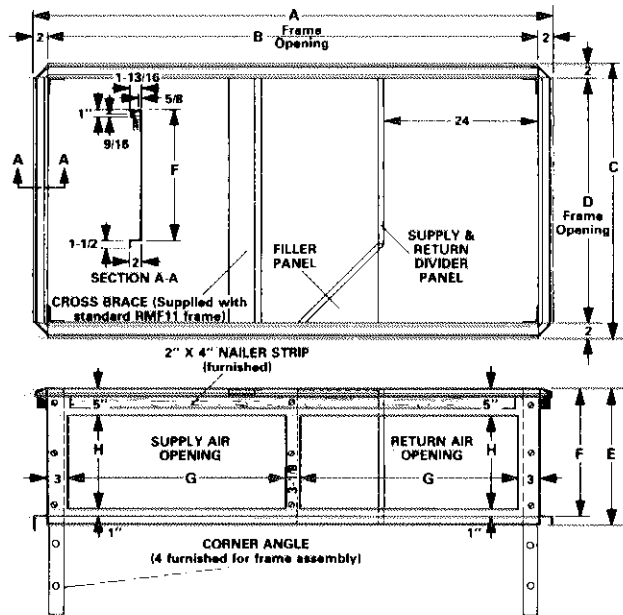

Model No.	A	B	C	D	E	F	G	H
RMFH11-95	79-5/8	75-5/8	41-5/8	37-5/8	22	20-1/2	33-1/4	14-1/2
RMFH11-135	85-5/8	81-5/8	59-5/8	55-5/8	25-1/2	24	36	18

K - RMFA11 Adaptor Mounting Frame

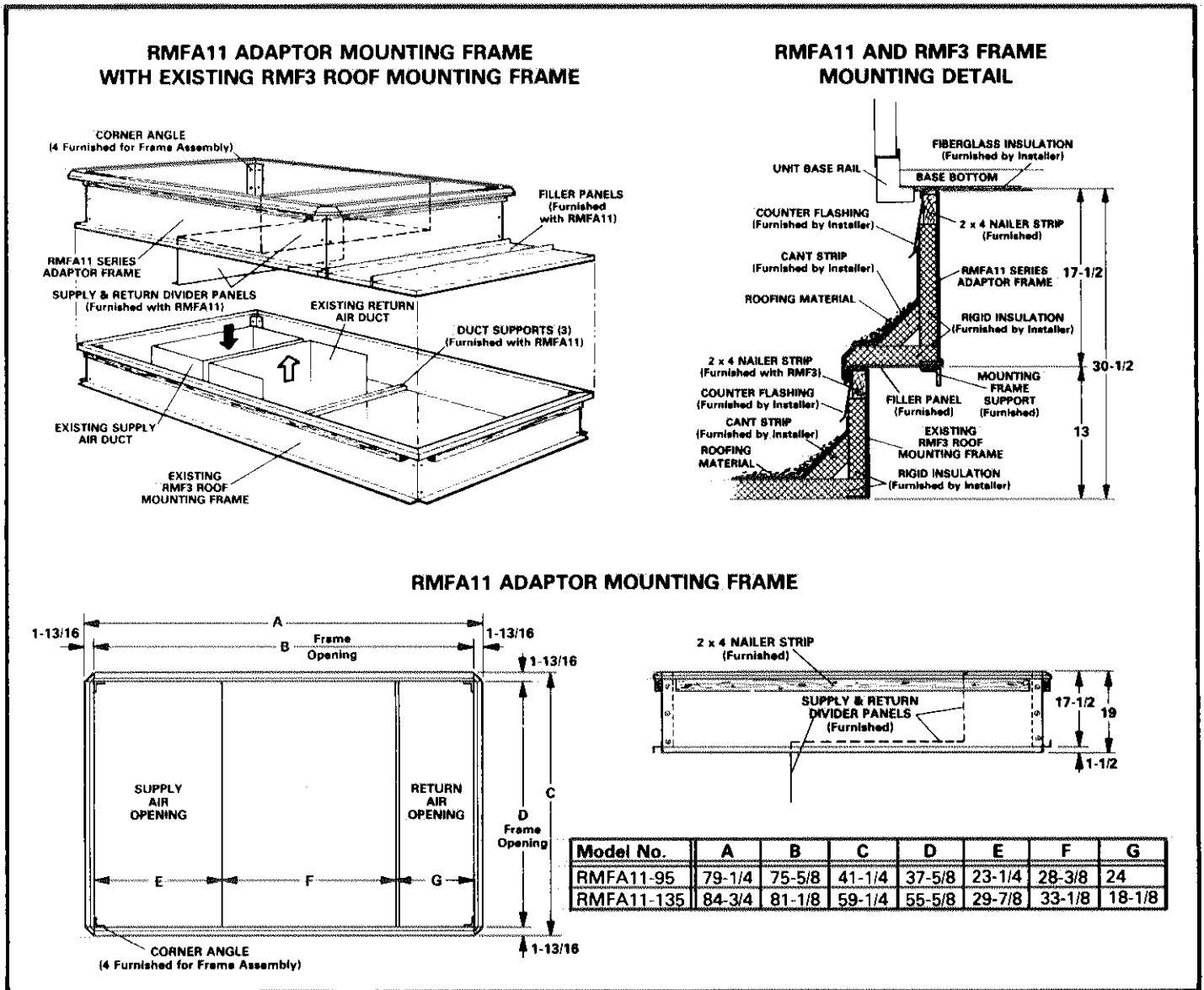

L - Power Supply Field Wiring (Figure 3)

Power Wiring Less Electric Heat

The unit rating plate lists minimum circuit ampacity and maximum fuse size. Connect power supply to high voltage leads in make-up box.

Power Wiring With Factory Installed Electric Heat

The unit rating plate lists minimum circuit ampacity and maximum fuse size. The incoming power connects to the power terminal block on hat section in high voltage junction box.

If the application includes a status panel, the "1, 1" electric heat lead must loop around a current sensing relay (K20). Loop once for "Q" voltage or twice for "G" or "J" voltage. The relay must be ordered separately.

Power Wiring With Field Installed Electric Heat

1 - The "Heater Installed" plate on unit access panel lists the

minimum circuit ampacity and maximum fuse size for the CHP11 combined with the various heaters.

- 2 - The incoming power connects to the power terminal block on hat section which installs in high voltage junction box.
- 3 - The electric heat leads also connect to this terminal block. All "1" leads to L1, "2" leads to L2, and "3" leads to L3.
- 4 - If the application includes a status panel, the "1, 1" lead must loop around a current sensing relay. Loop once for "Q" voltage or twice for "G" or "J" voltage. The relay must be ordered separately.
- 5 - Wire T5 electric heat transformer per unit voltage. Lead "14" connects to common (black). Lead "13" connects to correct voltage — red (208V) and orange (230V & 460V).

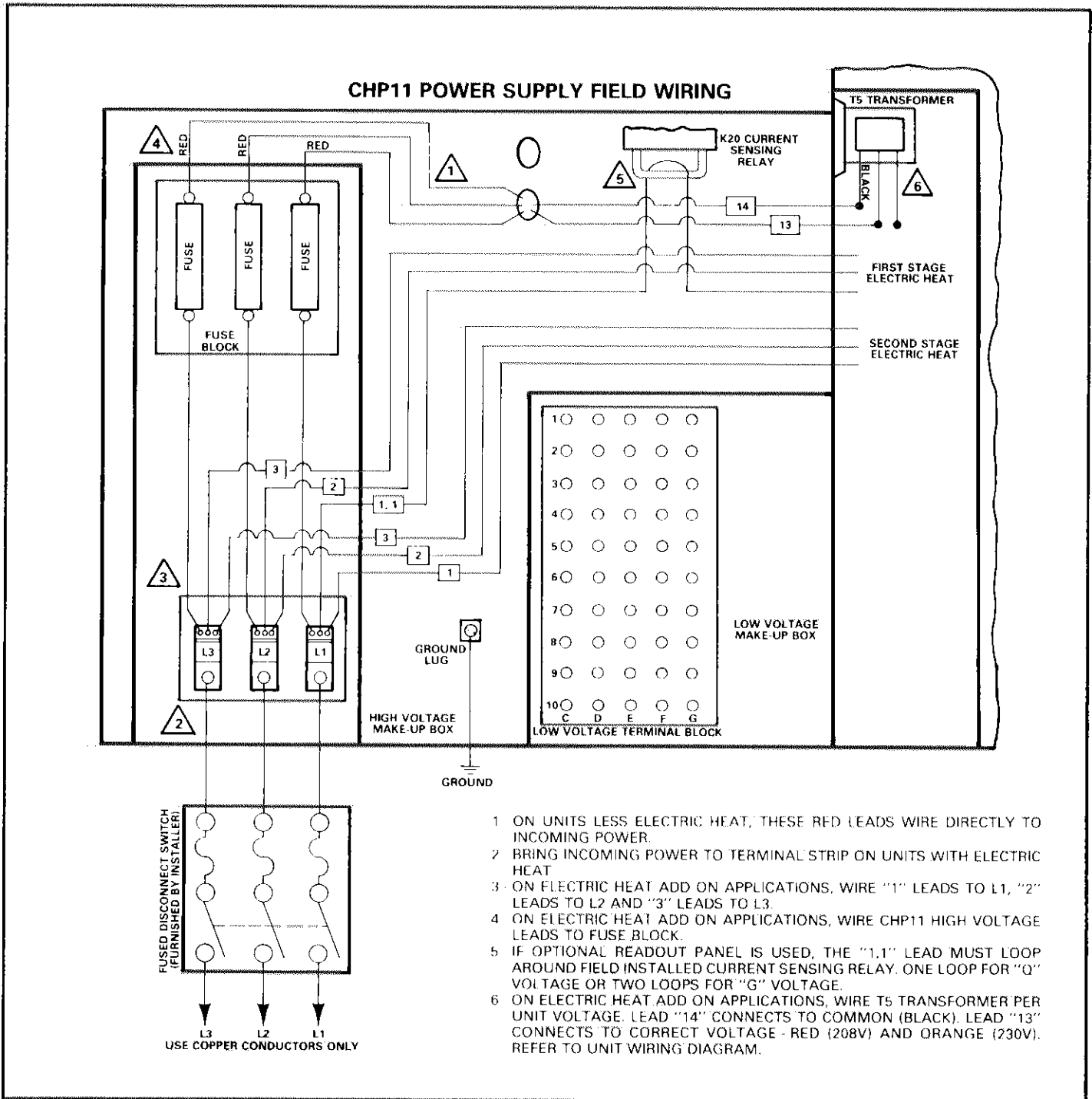

FIGURE 3

M - Low Voltage Field Wiring

- 1 - Low voltage connections are made at the terminal block located in the low voltage junction box.
- 2 - If switching subbase or switching status panel is used, remove jumper between TBC-9 & TBC-10.
- 3 - If application includes electric heat and status panel option, the K20 current sensing relay must be field installed and wired.
- 4 - If application includes hot water heat and status panel

option, the K24 electronic relay must be field installed and wired.

- 5 - Figure 4 illustrates field wiring for room thermostat or transmitter, switching subbase, status panel and electric heat. Figure 5 illustrates field wiring for room thermostat or transmitter, switching status panel and electric heat. Do not route DC wires in same conduit or raceway as AC current. AC will interfere with the DC ramp signals.

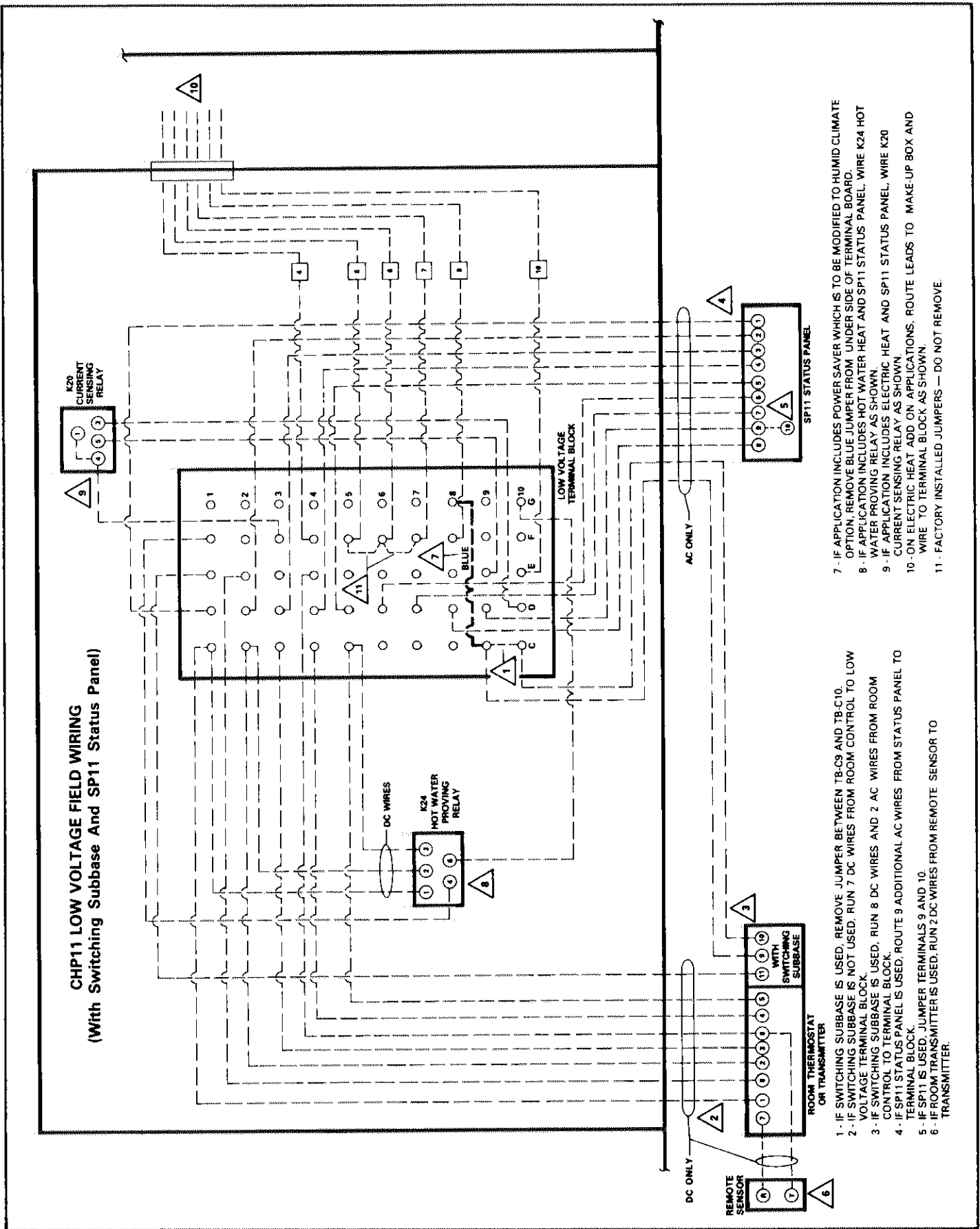

CHP11 LOW VOLTAGE FIELD WIRING
(With Switching Subbase And SP11 Status Panel)

- 1 - IF SWITCHING SUBBASE IS USED, REMOVE JUMPER BETWEEN TB-C9 AND TB-C10.
- 2 - IF SWITCHING SUBBASE IS NOT USED, RUN 7 DC WIRES FROM ROOM CONTROL TO LOW VOLTAGE TERMINAL BLOCK.
- 3 - IF SWITCHING SUBBASE IS USED, RUN 8 DC WIRES AND 2 AC WIRES FROM ROOM CONTROL TO TERMINAL BLOCK.
- 4 - IF SP11 STATUS PANEL IS USED, ROUTE 9 ADDITIONAL AC WIRES FROM STATUS PANEL TO TERMINAL BLOCK.
- 5 - IF SP11 IS USED, JUMPER TERMINALS 9 AND 10.
- 6 - IF ROOM TRANSMITTER IS USED, RUN 2 DC WIRES FROM REMOTE SENSOR TO TRANSMITTER.
- 7 - IF APPLICATION INCLUDES POWER SAVER WHICH IS TO BE MODIFIED TO HUMID CLIMATE OPTION, REMOVE BLUE JUMPER FROM UNDER SIDE OF TERMINAL BOARD.
- 8 - IF APPLICATION INCLUDES HOT WATER HEAT AND SP11 STATUS PANEL, WIRE K24 HOT WATER PROVING RELAY AS SHOWN.
- 9 - IF APPLICATION INCLUDES ELECTRIC HEAT AND SP11 STATUS PANEL, WIRE K20 CURRENT SENSING RELAY AS SHOWN.
- 10 - ON ELECTRIC HEAT ADD ON APPLICATIONS, ROUTE LEADS TO MAKE-UP BOX AND WIRE TO TERMINAL BLOCK AS SHOWN.
- 11 - FACTORY INSTALLED JUMPERS — DO NOT REMOVE.

- 1 - IF SWITCHING SUBBASE IS USED, REMOVE JUMPER BETWEEN TB-C9 AND TB-C10.
- 2 - IF SWITCHING SUBBASE IS NOT USED, RUN 7 DC WIRES FROM ROOM CONTROL TO LOW VOLTAGE TERMINAL BLOCK.
- 3 - IF SWITCHING SUBBASE IS USED, RUN 8 DC WIRES AND 2 AC WIRES FROM ROOM CONTROL TO TERMINAL BLOCK.
- 4 - IF SP11 STATUS PANEL IS USED, ROUTE 9 ADDITIONAL AC WIRES FROM STATUS PANEL TO TERMINAL BLOCK.
- 5 - IF SP11 IS USED, JUMPER TERMINALS 9 AND 10.
- 6 - IF ROOM TRANSMITTER IS USED, RUN 2 DC WIRES FROM REMOTE SENSOR TO TRANSMITTER.

FIGURE 4

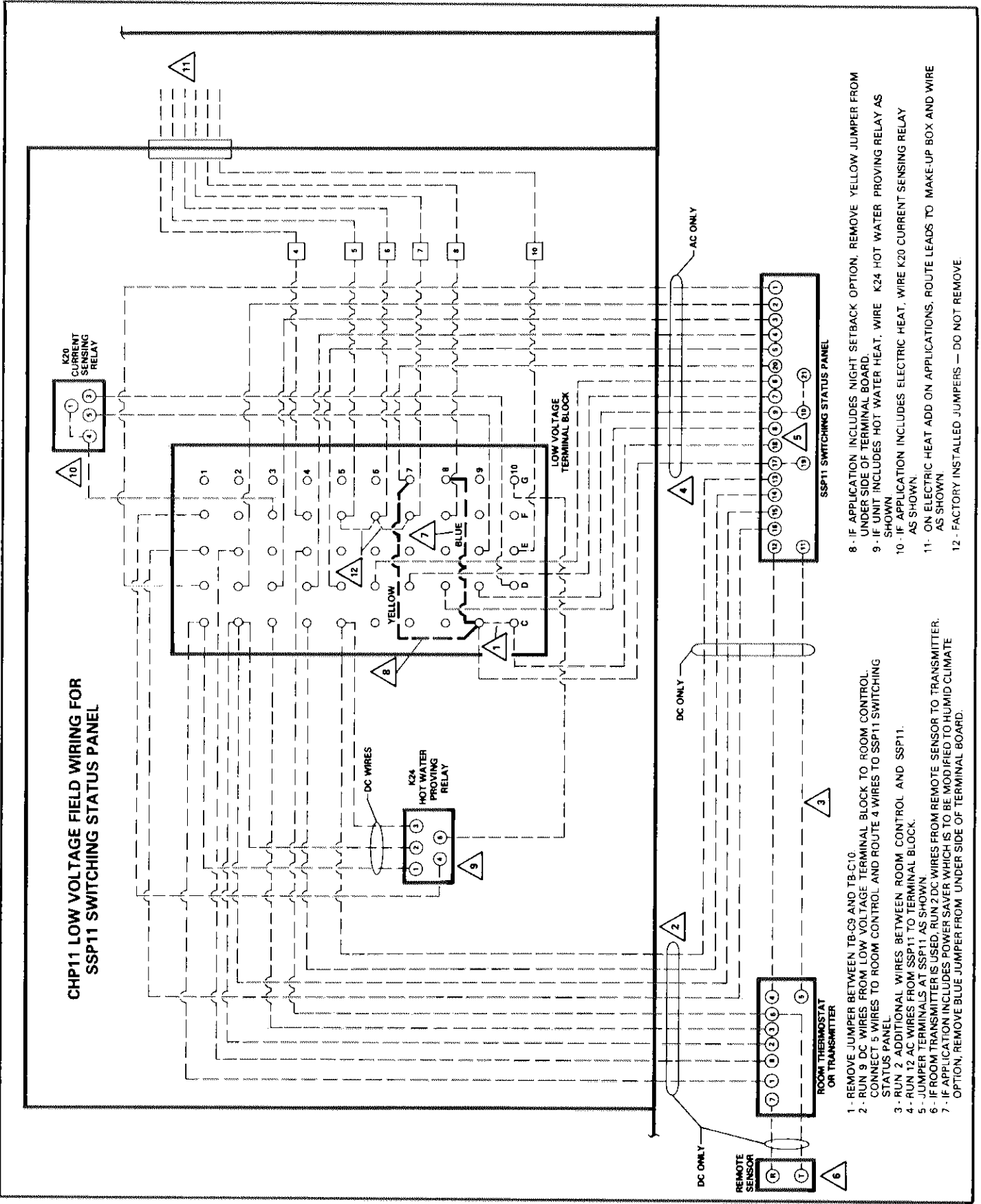

CHP11 LOW VOLTAGE FIELD WIRING FOR
SSP11 SWITCHING STATUS PANEL

- 8 - IF APPLICATION INCLUDES NIGHT SETBACK OPTION, REMOVE YELLOW JUMPER FROM UNDER SIDE OF TERMINAL BOARD.
- 9 - IF UNIT INCLUDES HOT WATER HEAT, WIRE K24 HOT WATER PROVING RELAY AS SHOWN
- 10 - IF APPLICATION INCLUDES ELECTRIC HEAT, WIRE K20 CURRENT SENSING RELAY AS SHOWN
- 11 - ON ELECTRIC HEAT ADD ON APPLICATIONS, ROUTE LEADS TO MAKE-UP BOX AND WIRE AS SHOWN
- 12 - FACTORY INSTALLED JUMPERS — DO NOT REMOVE.

- 1 - REMOVE JUMPER BETWEEN TB-C9 AND TB-C10
- 2 - RUN 9 DC WIRES FROM LOW VOLTAGE TERMINAL BLOCK TO ROOM CONTROL. CONNECT 5 WIRES TO ROOM CONTROL AND ROUTE 4 WIRES TO SSP11 SWITCHING STATUS PANEL
- 3 - RUN 2 ADDITIONAL WIRES BETWEEN ROOM CONTROL AND SSP11.
- 4 - RUN 12 AC WIRES FROM SSP11 TO TERMINAL BLOCK.
- 5 - JUMPER TERMINALS AT SSP11 AS SHOWN
- 6 - IF ROOM TRANSMITTER IS USED, RUN 2 DC WIRES FROM REMOTE SENSOR TO TRANSMITTER.
- 7 - IF APPLICATION INCLUDES POWER SAVER WHICH IS TO BE MODIFIED TO HUMID CLIMATE OPTION, REMOVE BLUE JUMPER FROM UNDER SIDE OF TERMINAL BOARD.

FIGURE 5

III - REFRIGERANT SYSTEM

CHP11 units have dual independent refrigeration circuits. Each circuit includes a suction line accumulator and two filter-drier systems. Figures 6 and 7 show the refrigerant flow for the cooling and heating cycles. They also show the gauge manifold connections.

It is very critical not to overcharge a heat pump. It is desirable to charge the system in the cooling cycle if weather conditions permit. However, if the unit must be charged in the heating cycle, the charge should be rechecked in the cooling cycle when outdoor conditions permit.

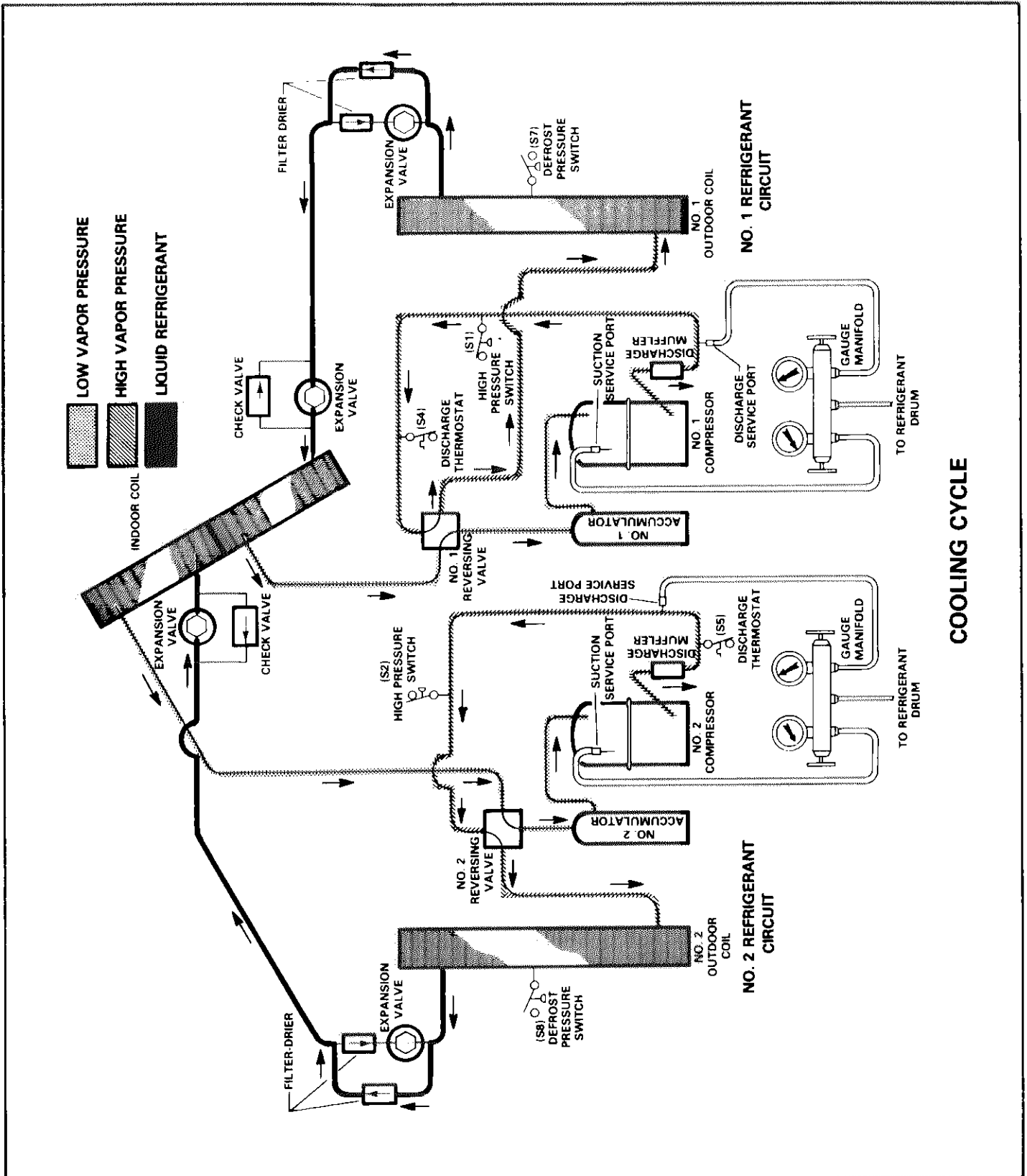

FIGURE 6

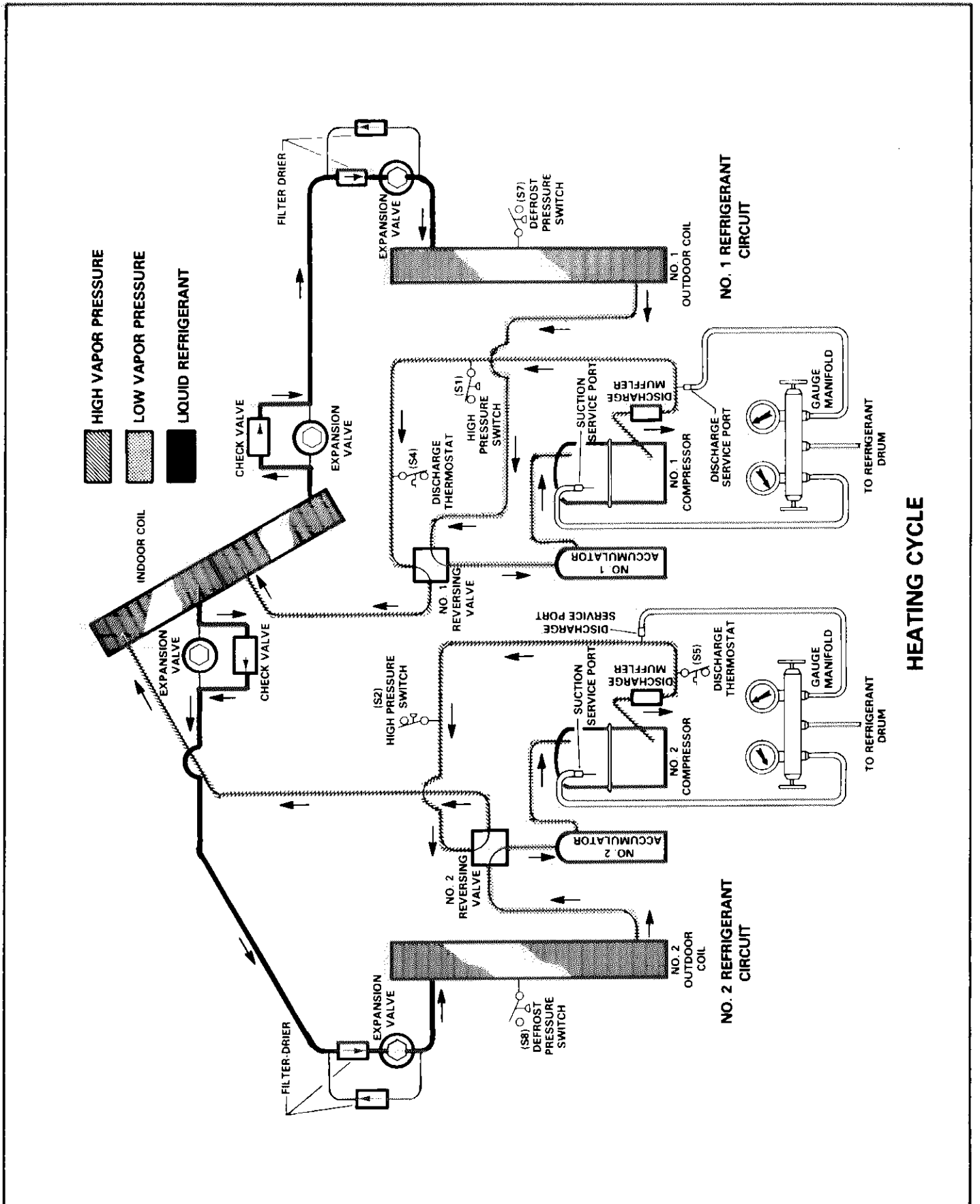

FIGURE 7

IV - CHP11 COMPONENTS

Table 2 lists the electrical components by their key numbers and then gives a brief description and location. Table 2 also lists control setpoints (if applicable). Key number labels are mounted next to each component for identification. Both the unit schematic diagram and the repair parts key the components.

A - Main Control Box

Figure 8 identifies the components in the main control box. On CHP11-953 "G" and "J" voltage units, K5 and K7 fan contactors are located in a box on the top of unit.

B - Make-up Box (Figure 9)

1 - Cooling Lockout Thermostat

The Cooling Lockout Thermostat (S6) has an adjustable range from 20°F to 80°F. It is factory set at 55°F. Both compressors are locked out during a cooling demand if the ambient temperature drops below setting.

2 - Outdoor Electric Heat Lockout Limit

The Outdoor Electric Heat Lockout Limit (S12) has an adjustable range from 20°F to 80°F. It is factory set at 55°F. Electric heat is locked out when ambient temperatures are above the setpoint. If the optional switching subbase or switching status panel is used, the limit can be by-passed by placing the system switch to emergency heat.

3 - Low Voltage Terminal Block

Low voltage field wiring connects to this terminal block. The terminals are identified by both letters and numbers.

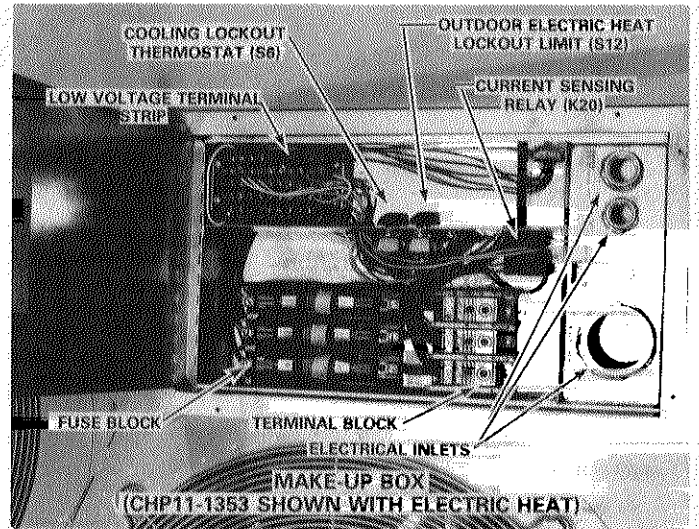

FIGURE 9

The columns are labeled "C" through "G" and the rows are numbered 1 through 10. For example to find TBD-5, locate column labeled "D" and then go to row number 5. This terminal designation is used in the unit wiring diagram.

4 - Hat Section (Electric Heat Usage)

On electric heat applications a hat section is added to the make-up box. A fuse block and high voltage terminal block are mounted on hat section. Line connections are made at terminal block.

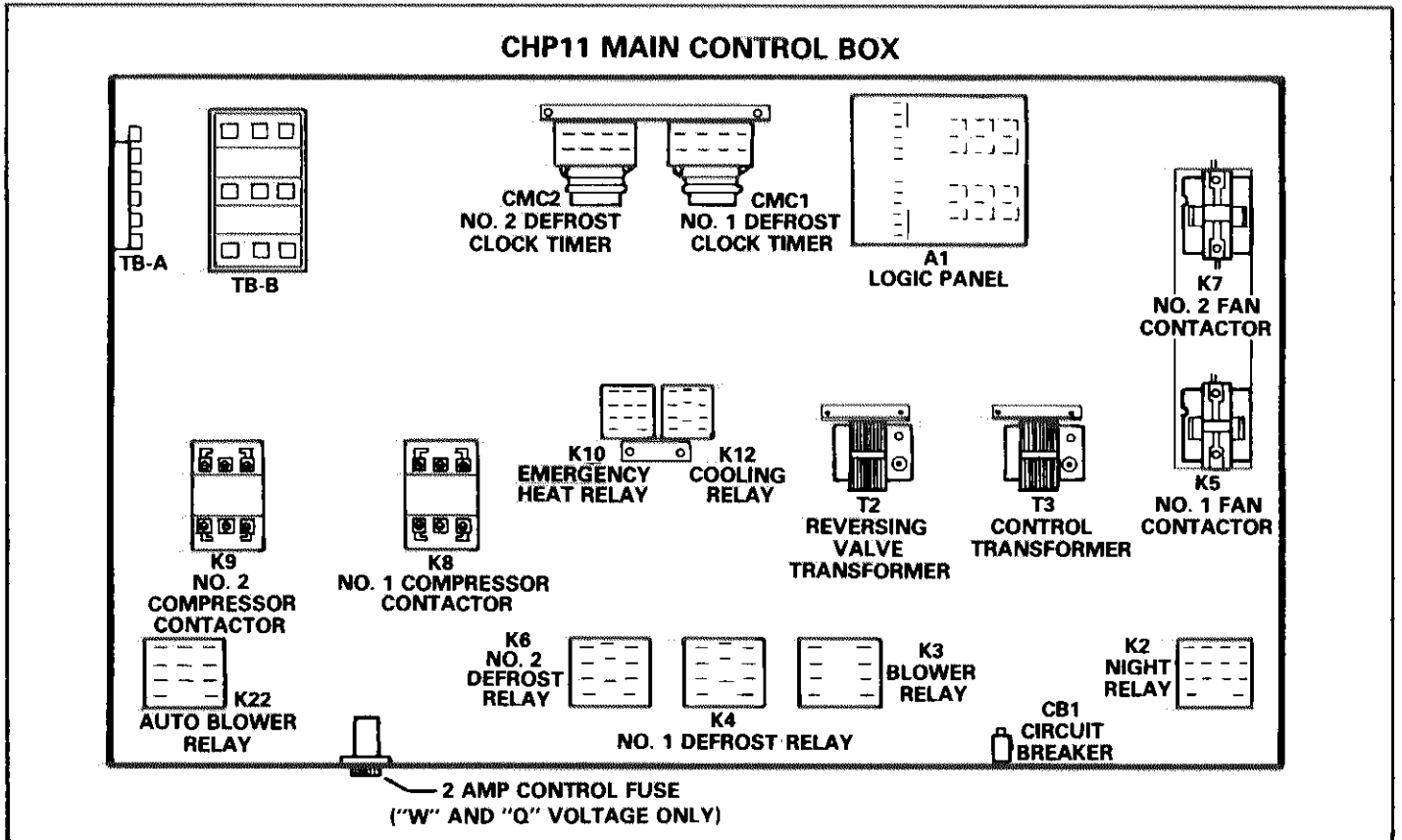

FIGURE 8

5 - Current Sensing Relay (K20)

This field installed relay is only used with a status panel on electric heat applications. It detects the absence of electric heat operation during a demand.

C - Compressor Compartment (Figure 10)

- 1 - Each compressor is protected with an internal line break overload. This device detects motor winding temperature to protect compressor from excessive heat and/or current draw. The compressors are also protected by an internal pressure relief valve which is set to open at a discharge and suction differential of 450 psig \pm 50. In addition each compressor has an insertion type self regulating crankcase heater.
- 2 - Each refrigerant circuit includes a Discharge Temperature Limit Switch and a High Pressure Switch for compressor protection. The discharge switch opens at 260°F and must be manually reset when temperature drops below 225°F. The top of discharge switch must be removed for access to reset button. Refer to Figure 11. The pressure switch opens at 410 psig and must be manually reset.
- 3 - Each refrigerant circuit also includes a Defrost Pressure Switch. This switch determines need for a defrost cycle. It makes at 45 psig and opens at 200 psig.
- 4 - The outdoor fan draws air through the outdoor coil and

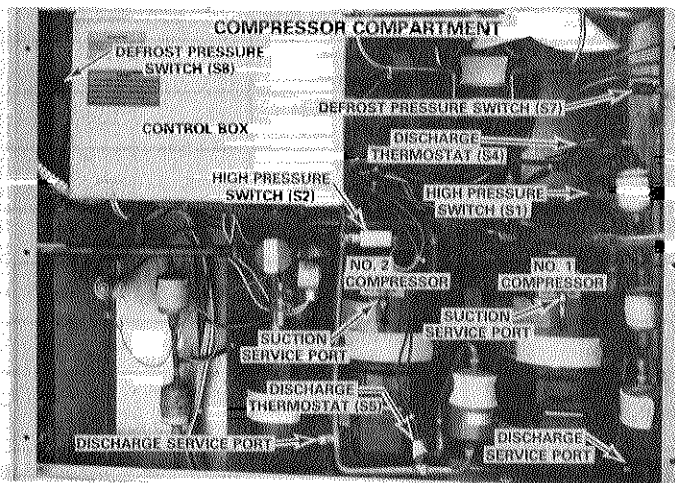

FIGURE 10

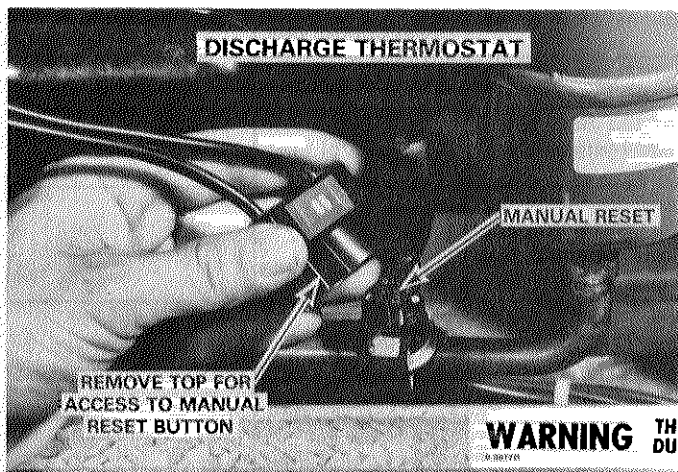

FIGURE 11

discharges it out the top of unit. For fan service access, remove the bolts securing fan assembly. Figure 12 illustrates the condenser fan and motor assemblies.

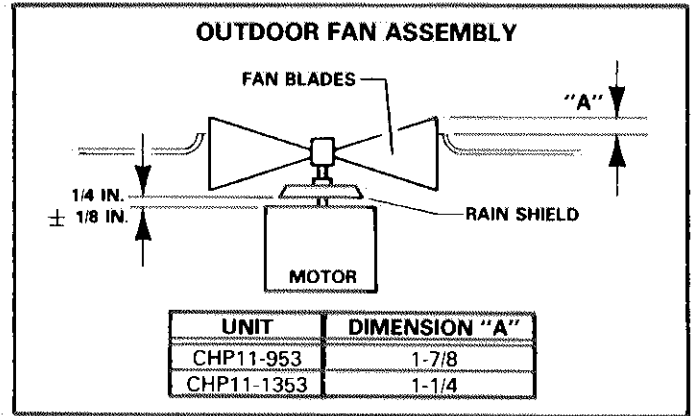

FIGURE 12

D - Blower Compartment (Figure 13)

- 1 - Table 3 lists the drive kit options.
- 2 - The blower control box sets next to blower housing.
- 3 - The indoor coil has two distinct stages. The top half is for the No. 2 refrigerant circuit while the bottom half is for the No. 1 circuit. This is a draw through coil.
- 4 - The discharge sensor is located in supply air stream.
- 5 - If optional status panel or switching status panel is used, Filter Switch (S14) mounts in blower compartment.

TABLE 3

Model No.	Nominal Motor Hp	Maximum Usuable Hp	Rpm Range Of All Available Drive Setups @ 1720 Rpm Motor Speed
CHP11-953	*1.5	1.725	805 - 1023
	3	3.45	805 - 1023
CHP11-1353	3	3.45	677 - 860
	5	5.75	896 - 1079

*NOTE - The 1-1/2 HP motor can not be used with over 15 KW of electric heat.

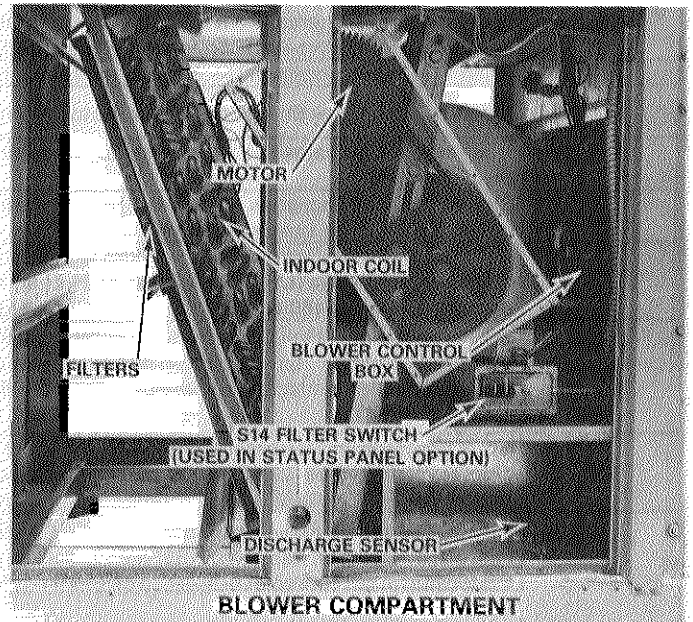

BLOWER COMPARTMENT

FIGURE 13

TABLE 2

COMPONENT	DESCRIPTION AND FUNCTION	LOCATION	SETTING
A1	Logic Panel — Receives the signal from room thermostat and balances this against the system output as determined by the discharge sensor; then initiates the heating or cooling modes as needed. Also modulates power saver closed with discharge temperatures between 62° and 50°F.	Main Control Box	----
A2	Room Thermostat or Transmitter — Generates heating and cooling ramp signals based on the temperature deviation from the dual setpoint adjustments and a thermistor. Thermistor is internal to thermostat and remote to transmitter.	Remote	Adj. 55° — 85°
B1 & B2	Compressors No. 1 & No.2 — Initiate DX cooling.	Compressor Compartment	----
B3	Indoor Blower Motor — Provides air supply through unit.	Blower Compartment	----
B4 & B5	Outdoor Fans No. 1 & No. 2 — Draws air across outdoor coil for heat transfer in the refrigeration cycle.	Compressor Compartment	----
B6	Power Saver Motor (optional) — Modulates outdoor dampers and return air dampers.	Power Saver	Minimum Position Adj. at Motor
B7	Motorized Water Valve — Initiates hot water operation.		----
C1 & C2	Capacitors — Condenser Fan.	Compressor Compartment	----
CB1	Circuit Breaker — Protects the logic panel.	Main Control Box	----
CR-1	Light Emitting Diode — Used in status panel to show operating mode and failure.	Status Panel	----
CMC1	Compressor No. 1 Defrost Clock Timer — The timer makes every 90 minutes to initiate defrost cycle if S7 has made.	Main Control Box	----
CMC2	Compressor No. 2 Defrost Clock Timer — The timer makes every 90 minutes to initiate defrost cycle if S8 has made.	Main Control Box	----
CMC3	Clock Timer (optional) — 24 Hour skip-a-day clock programs a daily schedule. Any day or days can be omitted.	Blower Compartment	----
DL2	Electric Heat Delay — Steps electric heat elements in 30 second time delay.	Electric Heat Control Box	----
DL3	Electric Heat Delay — Steps electric heat elements in 60 second time delay.	Electric Heat Control Box	----
DL6	Hot Water On Delay — This is a 180 second time delay which is used in the status panel circuit on hot water applications.	Blower Compartment	----
DL8	Electric Heat Delay — Steps electric heat elements in 180 second time delay.	Electric Heat Control Box	----
F	Fuses — Circuit protectors.	Throughout Unit	----
HR1 & HR2	No. 1 & No. 2 Compressor Crankcase Heaters — Warms the compressor to prevent liquid refrigerant from migrating to compressor during off cycles and "slugging" it on start-up. (Continuously Energized)	Compressor	----
HR3	Electric Elements (optional) — Provide resistance heat.	Heating Section	----
K1	Blower Contactor — Energizes blower motor. Is energized by K3.	Blower Control Box	----
K2	Nite Relay — Activates the night setback mode when optional clock timer contacts make.	Main Control Box	----
K3	Blower Relay — Energizes K1 to start blower motor. When de-energized it drives power saver motor B6 closed.	Main Control Box	----
K4	No. 1 Compressor Defrost Relay — With a defrost demand this relay energizes reversing valve (L1). On 200 & 230 volt units it directly de-energizes condenser fan B4. On 460 & 575 voltage units it energizes K5.	Main Control Box	----
K5	NO. 1 Outdoor Fan Contactor — On 460V & 575V units, this relay de-energizes outdoor fan motor (B4) during defrost cycle. On CHP11-953 units it is located in fan contactor box, while on CHP11-1353 units it is in main control box.	Fan Contactor Box or Main Control Box	----
K6	No. 2 Compressor Defrost Relay — With a defrost demand this relay energizes reversing valve (L2). On 200V & 230V units it directly de-energizes outdoor fan B5. On 460V & 575V voltage units, it energizes K7.	Main Control Box	----
K7	No. 2 Outdoor Fan Contactor — On 460V & 575V units, this relay de-energizes outdoor fan motor (B5) during defrost cycle. On CHP11-953 units it is located in fan contactor box, while on CHP11-1353 units it is in main control box.	Fan Contactor Box or Main Control Box	----
K8	No. 1 Compressor Contactor — Energizes compressor B1.	Main Control Box	----

TABLE 2 (Continued)

COMPONENT	DESCRIPTION AND FUNCTION	LOCATION	SETTING
K9	No. 2 Compressor Contactor — Energizes compressor B2.	Main Control Box	---
K10	Emergency Heat Relay — If switching subbase is used, this relay bypasses S12. Also locks out compressors when energized.	Main Control Box	---
K12	Cooling Relay — "C1" at logic panel (A1) energizes this relay. It energizes blower relay (K3) during periods of intermittent blower operation. It must be energized before compressors can be activated.	Main Control Box	---
K15	No. 1 Electric Heat Contactor — Energizes first stage of electric heat.	Electric heat Control Box	---
K16	No. 2 Electric Heat Contactor — Energizes second stage of electric heat.	Electric Heat Control Box	---
K17	No. 3 Electric Heat Contactor — Energizes third stage of electric heat.	Electric Heat Control Box	---
K18	No. 4 Electric Heat Contactor — Energizes fourth stage of electric heat.	Electric Heat Control Box	---
K19	Electric Heat Relay — Relay is energized through "H3" at logic panel (A1) and S12 or K10-2. Initiates electric heat if S11 is made.	Electric Heat Control Box	---
K20	Current Sensing Relay — Used only with SP11 status panel. Detects the absence of electric heat operation (during a demand) to light the no heat light at status panel.	Field Installed in Make-up Box	---
K22	Auto Blower Relay — K22 is energized on a compressor demand through either "H1" or "C2" on logic panel (A1). It energizes blower relay (K3) during periods of intermittent blower operation.	Main Control Box	---
K24	Hot Water Proving Relay — This electronic relay is used in the status panel circuit to verify a heating demand.	Field Installed	---
K25	Humid Climate Option — This field provided and field installed relay eliminates power saver operation during excessive humidity conditions.	Field Installed	---
L1 & L2	No. 1 & No. 2 Reversing Valve — Are energized on a cooling or defrost demand. They switch refrigerant cycle.	Compressor Compartment	---
R1	Night Heating Operation Resistor — Used in night setback option to determine degree of heating setback.	Make-up Box	(5°, 10° or 15°F)
R2	Night Cool Setup Resistor — Used in night setback option to determine degree of cooling setup.	Make-up Box	(5°, 7°, 9°, 10°, 13° or 15°F)
RT1	Discharge Sensor — Sends a dc current voltage to logic panel which is equivalent to the discharge temperature.	Blower Compartment	
RT2	Remote Room Sensor (optional) — This is the thermistor that is used with the room transmitter option.	Remote	---
S1	No. 1 High Pressure Switch — Shuts off compressor (B1) when refrigerant pressure rises above setting. Must be manually reset.	Compressor Compartment	410 psig out
S2	No. 2 High Pressure Switch — Shuts off compressor (B2) when refrigerant pressure rises above setting. Must be manually reset.	Compressor Compartment	410 psig out
S4	No. 1 Discharge Thermostat — Shuts off compressor (B1) when discharge temperature rises above setting. Must be manually reset with temperature below 225°F. The top of switch must be removed for access to reset button.	Compressor Compartment	260° + 6°F out 225°F in
S5	No. 2 Discharge Thermostat — Shuts off compressor (B2) when discharge temperature rises above setting. Must be manually reset with temperature below 225°F. The top of switch must be removed for access to reset button.	Compressor Compartment	260° + 6°F out 225°F in
S6	Cooling Lockout Thermostat — Shuts off all cooling compressor operation when ambient temperature drops below setting. Factory set at 55°F.	Make-up Box	Adj. 20°F to 80°F
S7	No. 1 Pressure Defrost Switch — Switch makes at 45 psig vapor pressure. When CMC1 timer makes, K4 is energized to initiate defrost. When vapor pressure rises to 200 psig, switch opens to terminate defrost cycle.	Compressor Compartment	45 psig in 200 psig out
S8	No. 2 Pressure Defrost Switch — Switch makes at 45 psig vapor pressure. When CMC2 timer makes, K6 is energized to initiate defrost. When vapor pressure rises to 200 psig, switch opens to terminate defrost cycle.	Compressor Compartment	45 psig in 200 psig out
S11	Electric Heat Limit (Used with electric heat) — Drops out all electric heat when temperature exceeds setpoint.	Heating Section	953 (160°F On/120°F Off) 1353(150°F On/(10°F Off)
S12	Outdoor Electric Heat Limit — Locks out electric heat when ambient temperature is above setpoint. Factory set at 55°F.	Make-up Box	Adj. 20° to 80°F
S13	Enthalpy Control (Used with power saver) — Senses heat content of outside air. When heat content rises above setpoint, control switches to close outdoor dampers to minimum position.	Fresh Air Intake	"A" Adj.
S14	Filter Switch — Used with optional status panel. Indicates restricted air flow through the filters.	Blower Compartment	---
S17	Freezestat (Used with hot water) - Prevents coil freezing during a no demand condition. The control opens between 32° - 41°F and then closes again between 50° - 60°F.	Blower Compartment	32° — 41°F open 50° — 60°F close

TABLE 2 (Continued)

COMPONENT	DESCRIPTION AND FUNCTION	LOCATION	SETTING
S18	System Switch — This switch, used on optional switching subbase or switching status panel, changes operating mode.	Switching Subbase	----
S19	Fan Switch — This switch, used on optional switching subbase or switching status panel, changes blower operation.	Switching Subbase	----
S20	Electric Heat Secondary Limit - This one time limit drops out the elements at excessive temperatures.	Heating Section	185°F
S21	Temperature Indicating Thermostat — Used within status panel circuit to indicate a no heat condition for hot water.	Blower Compartment	104°F
T1	Power Transformer — On 460V & 575V units, T1 drops line voltage to 220V for the control circuit voltages. (200V & 230V)	Compressor Compartment	----
T2	Reversing Valve Transformer — Provides 24V power for reversing valves (L1 & L2), K1, K2, K5 and K7.	Main Control Box	----
T3	Control Transformer — Provides 24V power to the control circuit.	Main Control Box	----
T4	Power Saver Transformer — Provides 24 volts to power saver motor (B6). Has multi-tap leads to choose between 200V & 230V input when field installing.	Power Saver	----
T5	Electric Heat Transformer — Provides 24 volts for electric heat control circuit. Has multi-tap leads to choose between 200V & 230V input when field installing.	Electric Heat Control Box	----
T6	Hot Water Transformer — Provides 24V power to hot water motor valve.	Blower Compartment	----
TB-A	High Voltage Terminal Block — 3 Phase line voltage.	Main Control Box	----
TB-B	High Voltage Terminal Block — 1 Phase 230V control voltage.	Main Control Box	----
TB-C, D, E, F & G	Low Voltage Terminal Block	Make-up Box	----

V - BLOWER OPERATION AND ADJUSTMENTS

A - Blower Operation

- Units with standard room thermostat subbase:
Blower operates continuously in normal operation. Units with optional night operation controls will have intermittent blower operation during night control period.
- Units with switching subbase or switching status panel:
Blower operation is manually set at the fan switch. In "ON" position the blower operates continuously. Intermittent blower will only occur if optional night operation controls are installed. During night operation the blowers will cycle with demand. With fan switch in "Auto", the blower cycles with demand. Blower and entire unit will be off with fan switch in "Off" position.

B - Determining Unit CFM

- The following measurements must be made with a dry indoor coil. Run blower without a heating or cooling demand. The air filters must be in place while taking measurements.
- Measure static pressure external to unit.
- Measure the indoor blower motor RPM.
- Refer to Blower Performance Chart on page 5. Use the static pressure and RPM readings to determine unit CFM.
- The CFM can be adjusted at the motor pulley on CHP11-1353 units. Loosen the allen screw. Turn adjustable sheave clockwise to increase CFM or counter-clockwise to decrease CFM. See Figure 14.

On CHP11-953 units the pulley has a fixed sheave and there is no adjustment. On 953 electric heat add on applications, a substitute pulley (provided) must be field installed.

C - Blower Belt Adjustment

Maximum life and wear can be obtained from belts only if

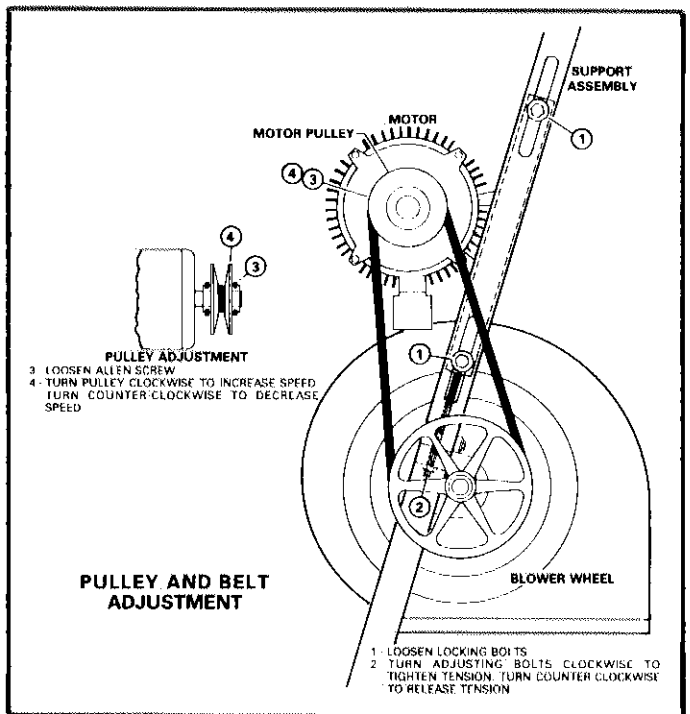

FIGURE 14

proper pulley alignment and belt tension are maintained. Initially, tension new belt(s) after a run in period of 24-48 hours. This allows belt to stretch and seat in the grooves. To adjust belt tension, loosen 4 locking bolts. Turn adjusting bolt to slide motor up or down. See Figure 14.

VI - THERMOSTAT OR TRANSMITTER OPERATION

A room control installed with a standard subbase allows only heating and cooling setpoint adjustment. The temperature gap between the setpoint levers represents the "no load"

band where no heating or cooling can occur. With levers positioned side by side, the no load band is 3°F. With levers wide apart, the no load band is 30°F.

A room control installed with an optional switching subbase or optional switching status panel will allow heating and cooling setpoint adjustment, system function selection and blower operation control. The system function switch is manually set for the desired operating mode:

- EM HT - Locks out compressors
- HEAT - Heatpump and auxiliary heat only
- AUTO - Automatic switch over to provide heating or cooling operation
- COOL - Cooling only

The fan switch controls blower and system operation:

- OFF - Blower off and entire unit (system) off.
- AUTO - Blower cycles with demand, system on
- ON - Blower continuous, system on.

The system switch should be set in "EM HT" position only when heatpump compressors are not operational. EM HT position locks out compressors so that only supplement heat can be utilized on a heating demand.

VII - CHP11 UNIT OPTIONS

A - Power Saver (Figure 15)

- 1 - The power saver motor modulates in response to the cooling ramp signal, discharge low limit feature, and enthalpy control setting. The range is 1.5 to 4VDC. The outside dampers are in minimum position at 1.5 volts and are open at 4 volts.
- 2 - The enthalpy control senses the heat content of the air. If heat content rises above control setpoint, the power saver dampers drive to minimum position. The recommended set point is "A". If power saver is allowing air which is too warm or humid to enter system, set control to a lower setpoint.

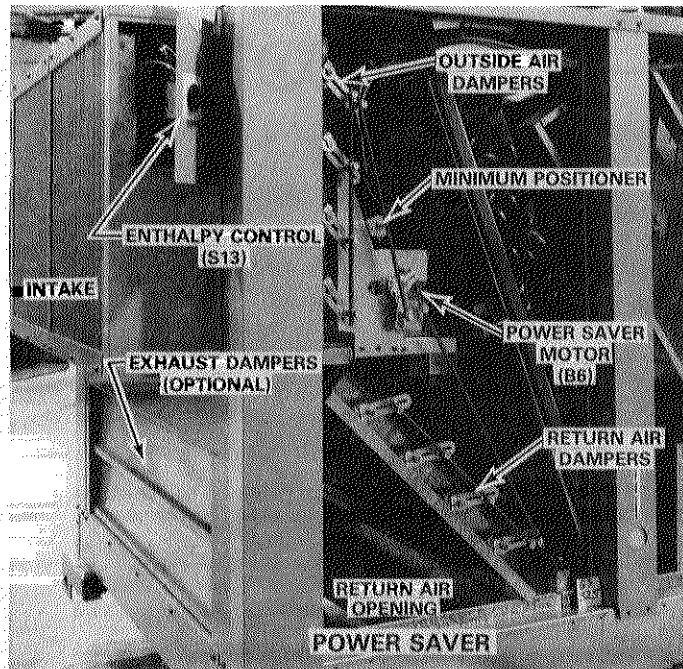

FIGURE 15

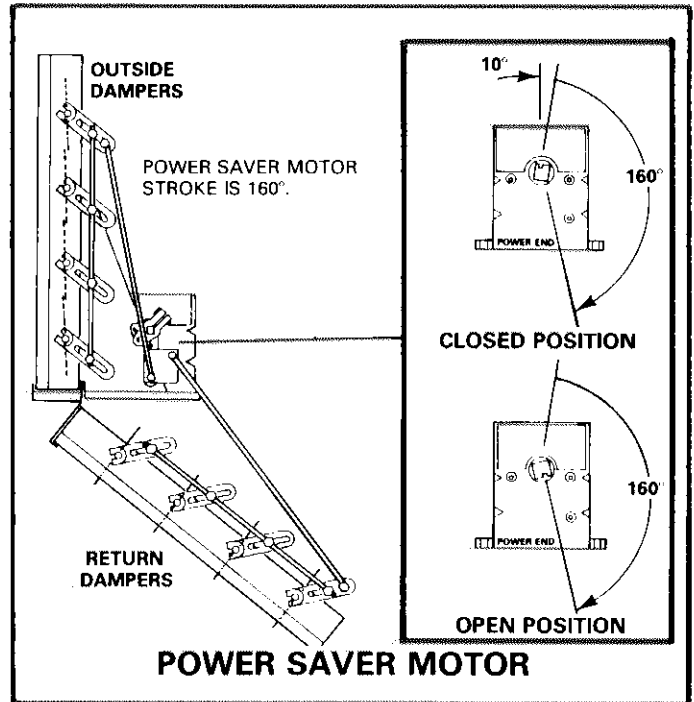

FIGURE 16

- 3 - The power saver motor includes a spring return feature which closes motor on a power failure. The motor stroke is 160 degrees as shown in Figure 16 and the timing is 40 seconds. With R-W terminals shorted or B leg open, the motor drives outside dampers closed. With R-B terminals shorted or W leg open, the motor drives outside dampers open.
- 4 - Dampers are factory adjusted. The dampers rotate 90 degrees. If adjustment is needed, drive the dampers closed and adjust each blade individually.
- 5 - Adjust minimum positioner with outside dampers at minimum position (turn enthalpy control to "D"). Rotate screw clockwise to open dampers or counterclockwise to close dampers. Table 4 lists the percentage of fresh air per damper blade opening. Return enthalpy control back to normal setting.

If desired a remote minimum positioner may be used in place of the one at motor bracket. Simply disconnect existing minimum positioner and wire the new one with "W" lead to TBC-6 and "R" lead to TBC-7. The remote minimum positioner rotates counterclockwise to open and clockwise to close.

TABLE 4

Damper Blade Angle	FRESH AIR PERCENTAGE (%)					
	Return Air Duct Static Pressure					
	0"		25"		5"	
	PSD11	OAD11	PSD11	OAD11	PSD11	OAD11
5°	13%	12%	20%	18%	30%	27%
10°	26	21	34	27	46	37
15°	37	27	46	33	57	41
20°	48	31	57	37	65	43
25°	58	34	66	38	74	44
30°	69	37	75	41	81	45
35°	79	40	84	43	88	46
40°	90	45	92	46	94	47

6 - Humid Climate Option:

In very humid climates it may be desirable to eliminate power saver operation during high humidity conditions. This would keep the outside dampers closed and blower motor stopped until there was a mechanical cooling demand. On a mechanical cooling demand, the outside dampers would open to minimum position for ventilation

and the blower would run. During favorable conditions the power saver would function normally.

This can be accomplished with the use of a switching subbase or switching status panel and the field installation of a special relay. Figure 17 shows the hook-up and explains the sequence of operation.

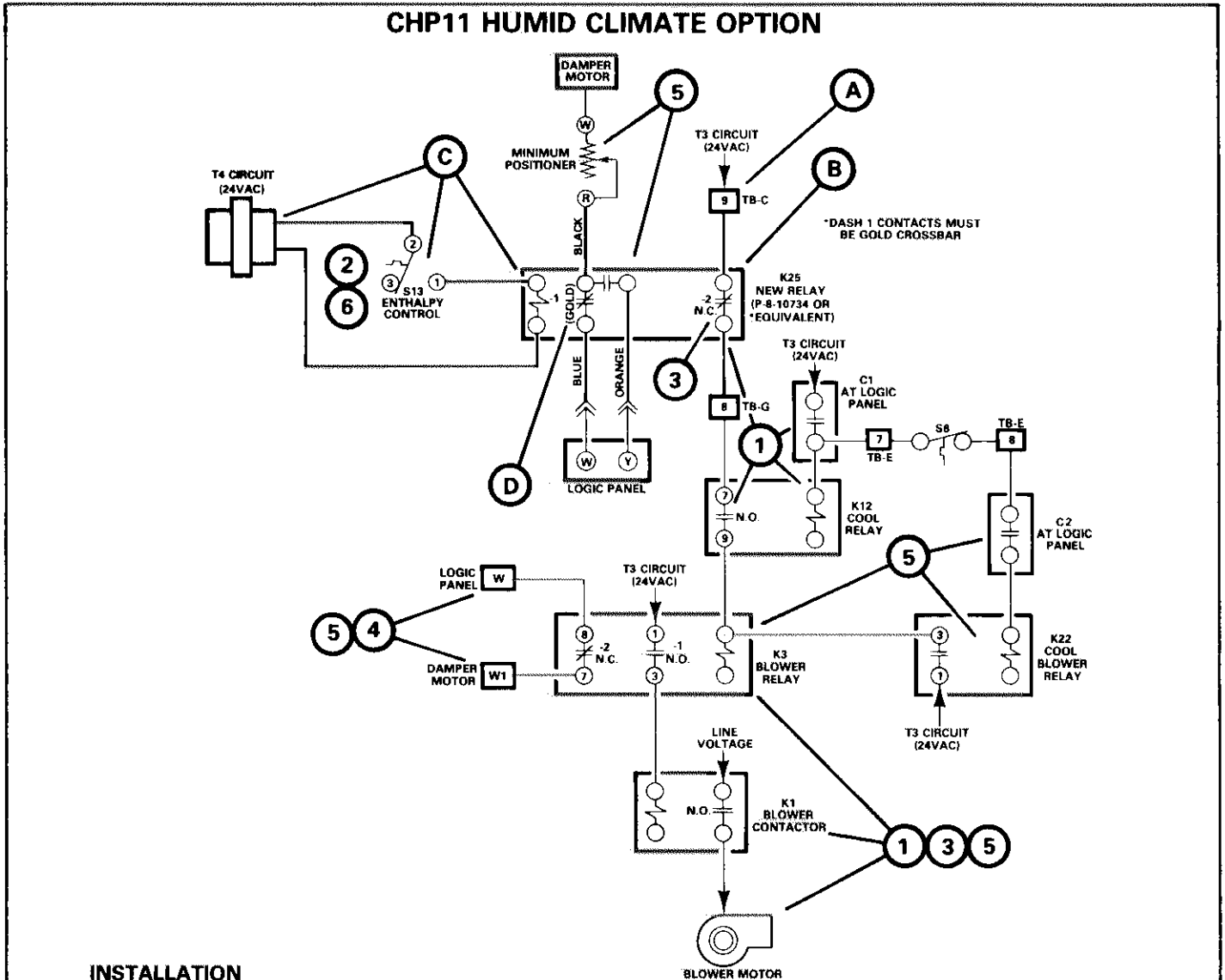

INSTALLATION

- A - Remove existing jumper from TBC-9 to TBG-8 at Low Voltage Terminal Block. This jumper is located on the under side of board.
- B - Connect K25-2 contacts to TBC-9 and TBG-8.
- C - Connect enthalpy control and K25 coil to the power saver transformer T4.
- D - Connect K25-1 contacts as follows:
 - Common — Black lead going to minimum positioner
 - N.C. — Blue lead going to "W" at logic panel
 - N.O. — Orange lead going to "Y" at logic panel
- E - Place fan switch to "Auto" on switching subbase or switching status panel.

OPERATION

- 1 - During low humidity power saver is used. "C1" makes at logic panel on demand to energize K12 Cool Relay. As K12 contacts make, K3 Blower Relay is energized through N.C. K25-2. K3 then energizes K1 Blower Contactor to start blower motor.
- 2 - Enthalpy control energizes K25 at excessive humidity.
- 3 - N.C. K25-2 contacts open to de-energize K3 Blower Relay, which in turn de-energizes K1. The blower motor stops.
- 4 - With K3 de-energized the outside dampers drive closed.
- 5 - On a compressor demand, "C2" makes at logic panel. This energizes K22 Auto Blower Relay thru C1 and S6. K22 energizes K3 to start blower motor. The outside dampers open to minimum position for ventilation.
- 6 - When outside air is again suitable for cooling, S13 de-energizes K25 to return system to power saver operation.

FIGURE 17

B - Fresh Air Dampers

In lieu of a power saver, the OAD11 outdoor air damper may be installed for minimum fresh air intake. This option is available with either manual or automatic damper control (damper motor). The damper motor has a remote minimum position control. This control rotates counterclockwise to open and clockwise to close outdoor air dampers. Table 4 lists the percentage of fresh air per damper blade opening.

C - Electric Heat (Figure 18)

1 - An ECH11-95 fits into a CHP11-953 while an ECH11-135 fits into a CHP11-1353. The ECH11 is available in four sizes, from one to four elements. In addition the ECH11 is also available in two voltages. The ECH11-W uses standard delta elements. The ECH11-G uses standard wye elements.

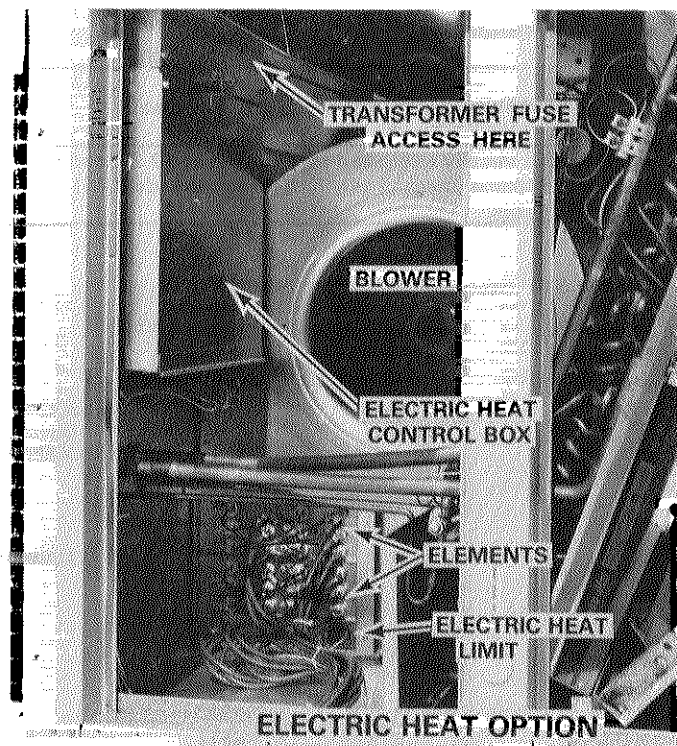

FIGURE 18

Table 5 lists the possible CHP11/ECH11 combinations and gives the corresponding KW input.

- 2 - The elements install in the heating section. The electric heat control box sets adjacent to blower housing. Figure 19 identifies components in the ECH11 control box.
- 3 - The Electric Heat Limit (S11) drops out all the elements when temperature exceeds setpoint. ECH11 heaters are protected by one time limits (S20). See Figure 20 for location of limits.
- 4 - Time delays stage the elements in 30, 60 and 180 second increments. Element staging is determined by CHP11 voltage and ECH11 heater size. Table 6 explains the operating sequence for each combination.
- 5 - Field installed ECH11-95 series heaters are packaged with a blower motor drive sheave. Replace sheave in CHP11-953 units.

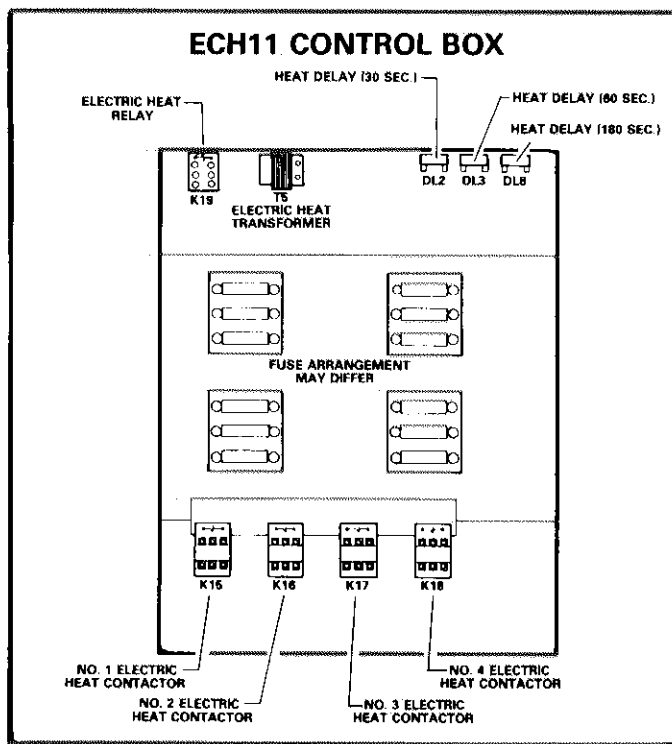

FIGURE 19

TABLE 5

CHA11 USAGE	ECH11 HEATER USAGE	NO. OF ELEMENTS	KW INPUT
CHP11-953-W CHP11-1353-W (200/60/3)	ECH11-953/1353-15-Q	1	10.4
	ECH11-953/1353-30-Q	2	20.8
	ECH11-953/1353-45-Q	3	31.3
	ECH11-953/1353-60-Q	4	41.7
CHP11-953-Q CHP11-1353-Q (230/60/3)	ECH11-953/1353-15-Q	1	13.8
	ECH11-953/1353-30-Q	2	27.5
	ECH11-953/1353-45-Q	3	41.3
CHP11-953-G CHP11-1353-G (460/60/3)	ECH11-953/1353-15-G	1	13.8
	ECH11-953/1353-30-G	2	27.5
	ECH11-953/1353-45-G	3	41.3
CHP11-953-J CHP11-1353-J (575/60/3)	ECH11-953/1353-15-G	1	13.7
	ECH11-953/1353-30-G	2	27.6
	ECH11-953/1353-45-G	3	41.3
CHP11-953-M CHP11-1353-M (380-420/50/3)	ECH11-953/1353-15-G	1	9.4 — 11.5
	ECH11-953/1353-30-G	2	18.8 — 23.0
	ECH11-953/1353-45-G	3	28.2 — 34.5

TABLE 6

CHP11 UNIT VOLTAGE	ECH11 HEATER	ELEMENT SEQUENCE
W (200/60/3) Q (230/60/3)	ECH11-953/1353-15 (1 Element)	1 element is energized by K15 when K19-2 makes.
W (200/60/3) Q (230/60/3)	ECH11-953/1353-30 (2 Elements)	The first element is energized by K15 when K19-2 makes. The second element is energized by K16 thirty seconds (DL2) after K19-2 makes.
W (200/60/3) Q (230/60/3)	ECH11-953/1353-45 (3 Elements)	The first element is energized by K15 when K19-2 makes. The second element is energized by K16 thirty seconds (DL2) after K19-2 makes. The third element is energized by K17 sixty seconds (DL3) after K19-2 makes.
W (200/60/3)	ECH11-953/1353-60 (4 Elements)	The first element is energized by K15 when K19-2 makes. The second element is energized by K16 thirty seconds (DL2) after K19-2 makes. The third element is energized by K17 sixty seconds (DL3) after K19-2 makes. The fourth element is finally energized by K18, 180 seconds (DL8) after K19-2 makes.
G (460/60/3) J (575/60/3) M (380-420/50/3)	ECH11-953/1353-15 (1 Element)	1 element is energized by K15 when K19-2 makes.
G (460/60/3) J (575/60/3) M (380-420/50/3)	ECH11-953/1353-30 (2 Elements)	2 elements are energized by K15 when K19-2 makes.
G (460/60/3) J (575/60/3) M (380-420/50/3)	ECH11-953/1353-45 (3 Elements)	2 elements are initially energized by K15 when K19-2 makes. The third element is energized by K16 thirty seconds (DL2) after K19-2 makes.

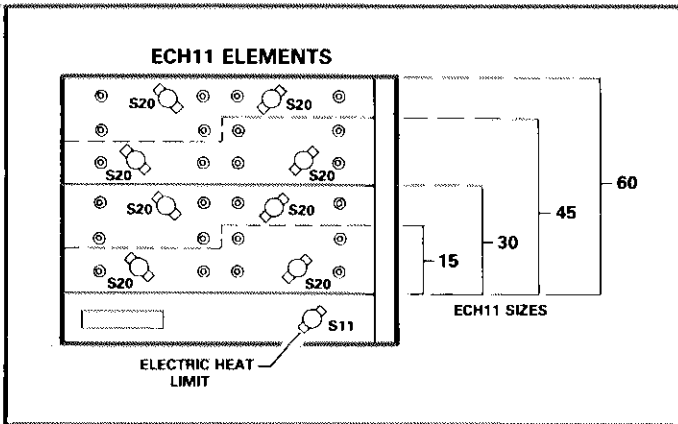

FIGURE 20

6 - Field installed ECH11 heaters (except ECH11-95-60-1Q) are also packaged with 3 additional fuses. On the units listed in Table 7, remove the existing fuses from fuse block and substitute these extra fuses.

TABLE 7

UNIT	BLOWER MOTOR	REMOVE	INSTALL
CHP11-953-1W, -2W	3 HP	50	60
CHP11-953-2Q	3 HP	50	60
CHP11-953-2G	3 HP	25	30
CHP11-1353-1W, -2W	5 HP	70	80

D - Hot Water (Figure 21)

General

1 - The factory installed hot water option fits into the heating

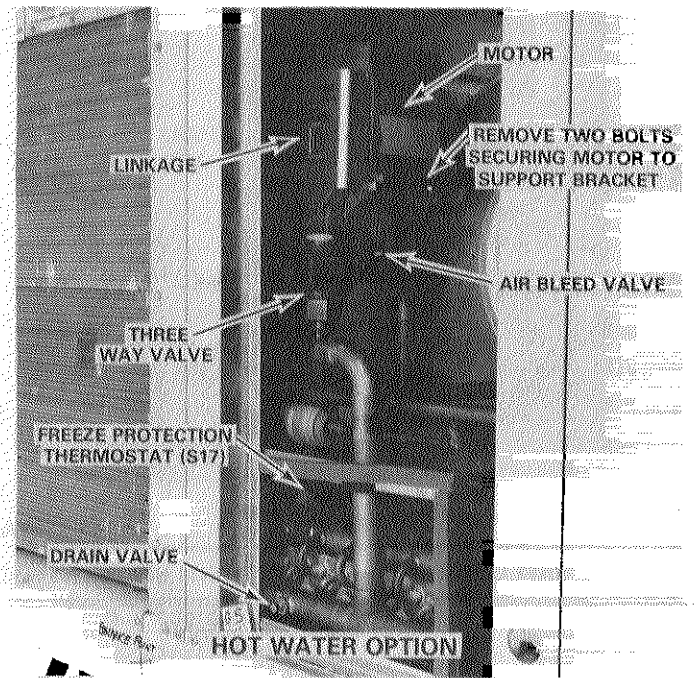

FIGURE 21

section. The coil is equipped with an air bleed valve and a drain valve. Figure 22 illustrates the system piping.

- 2 - The motorized three way valve either directs hot water through coil or by-passes coil.
- 3 - A manual balancing valve is located in the by-pass line to equalize pressure drop through coil.
- 4 - The flow rate through coil can be determined per Figure 23. A correction factor is included in illustration for the affects of glycol.

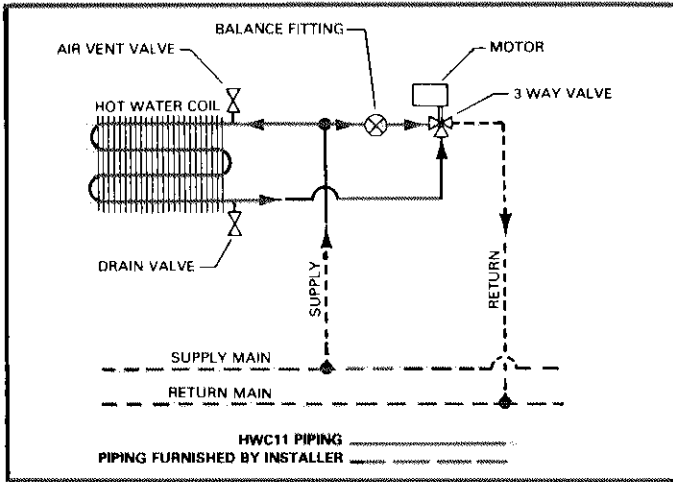

FIGURE 22

5 - Coil Btuh output can be determined by either of the following formulas. Table 8 lists the correction factors for a glycol solution. Multiply the calculated Btuh output by correction factor to obtain actual Btuh's.

$$(\text{Water Temp. Difference}) \times (500) \times (\text{gpm}) = \text{Btuh}$$

$$(\text{Air Temp. Rise}) \times (1.08) \times (\text{cfm}) = \text{Btuh}$$

TABLE 8

CAPACITY CORRECTION CHART	
% Glycol	Correction Factor
0	1.00
10	.97
20	.94
30	.91
40	.87
50	.84

Note - Multiply calculated capacity by correction factor

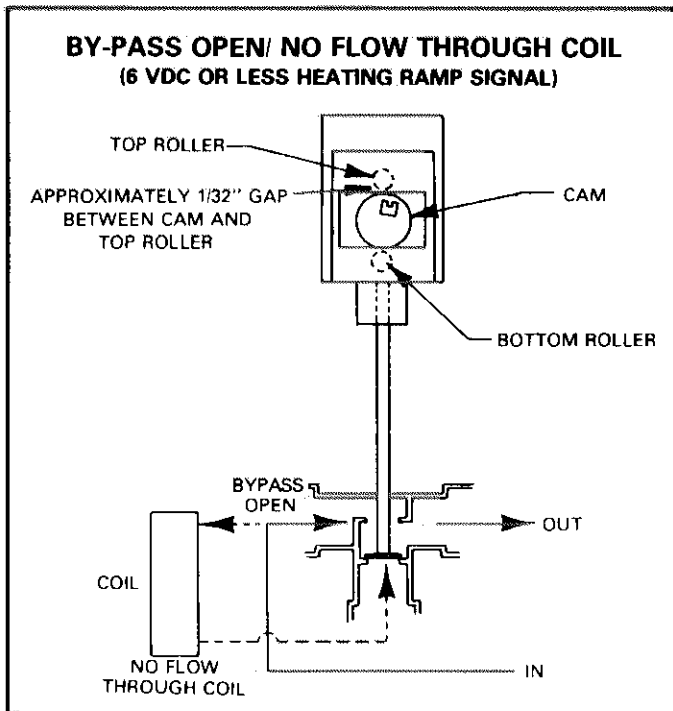

FIGURE 24

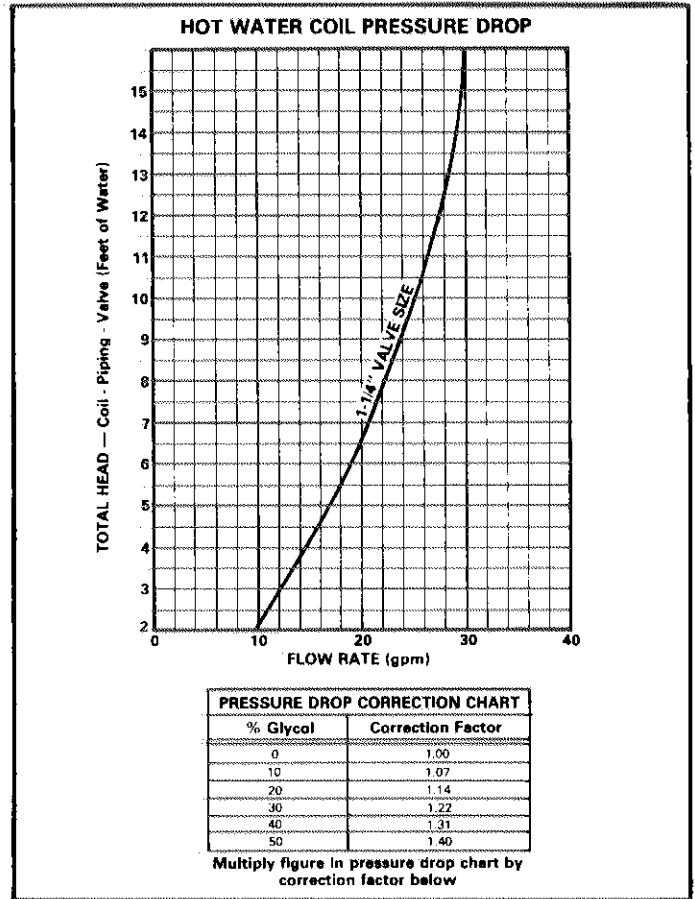

FIGURE 23

Operation

1 - The logic panel modulates the motor in response to the heating ramp signal. The range is 6 to 9 VDC. Figure 24

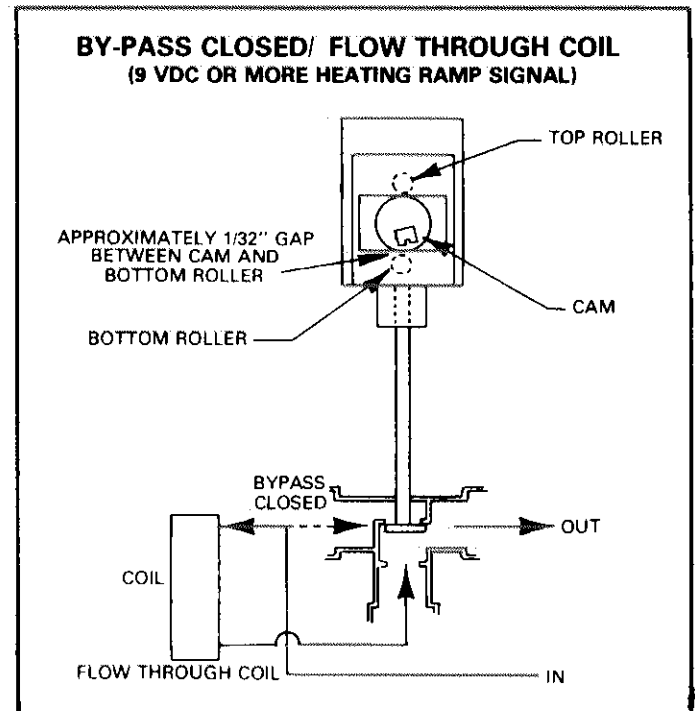

FIGURE 25

shows the motor and valve at 6 VDC or less. Figure 25 shows the motor and valve at 9 VDC or more.

- 2 - The motor includes a spring return feature. On a loss of power the motor opens the valve to coil to allow water flow, thus preventing freezing. The motor and valve are positioned as shown in Figure 24.
- 3 - A Freeze Protection Thermostat (S17) monitors manifold temperature. Thermostat closes at 32°-41°F which opens valve for water flow through coil. This prevents coil freezing during a no-demand condition. The thermostat opens on a temperature increase to 50°-60°F.
- 4 - A proving circuit, used in conjunction with the optional status panel, warns of a no heat condition. This circuit is composed of a field installed Hot Water Proving Relay (K24) a Sensing Thermostat (S21) and a Hot Water Delay (DL6). The relay makes on a heating demand as dictated by the heating ramp chart. The thermostat makes on a water temperature fall. If both devices make together, the "NO HEAT" light at status panel will light after a short delay caused by DL6. The K24 Electronic Relay makes at 10 VDC and opens at 8 VDC.

Checking Motor Operation

- 1 - Remove leads from terminal 5 at logic panel. Put a jumper across terminals "C" and "F" at motor. Valve motor shaft should rotate clockwise, raising valve stem. Refer to Figure 25.
 - a - At end of stroke notch in motor shaft should be down, at an angle 10° to right of vertical.
 - b - The motor should be free to run its complete stroke.
 - c - With the valve in this position, the by-pass line is closed and water will flow through coil.
- 2 - Remove jumper previously installed. Valve motor shaft should rotate counter-clockwise, lowering valve stem. Refer to Figure 24.
 - a - At end of stroke notch in motor shaft should be up, at an angle 10° to right of vertical.
 - b - Motor should be free to run its complete stroke.
 - c - With valve in this position, the by-pass line is open and water flow through coil is stopped.
- 3 - Remove lead from "TR" terminal at motor. Valve motor shaft should spring return clockwise, raising valve stem. See Figure 25. With the valve in this position, the by-pass line is closed and water will flow through coil.
- 4 - Reconnect leads at motor and logic panel.

E - Night Setback

A Night Setback Time Clock (16C1701) is available. The 24 hour skip-a-day clock programs a daily schedule. Any day or

days can be omitted. Wiring consists of jack plug connections in blower compartment.

The degree of heating setback or cooling setup is determined by separate resistors located at the low voltage terminal block. See Figure 26. The resistors can be substituted according to Table 9 to obtain the desired setting. Substitute resistors must be within 10% tolerance.

TABLE 9

°F	Night Setback (R1)	Cool Setup (R2)
5	7.5K	20K
7	---	18K
9	---	16K
10	3.6K*	15K
13	---	13K
15	2K	12K
Cool Lockout	---	1.2K**

*This resistor is factory installed for heating. There is a 7.5K resistor taped to side of low voltage junction box.

**This resistor is factory installed for cooling. Establishing a cooling setup value with a resistor of less than 1.2K ohm resistance will limit the maximum heat setback value to 12°F.

When an application includes night setback and switching status panel options, the "After Hour Timer" function must be field wired into the night setback circuit. Refer to Figure 5 for field hook-up.

Figure 27 explains night setback operation.

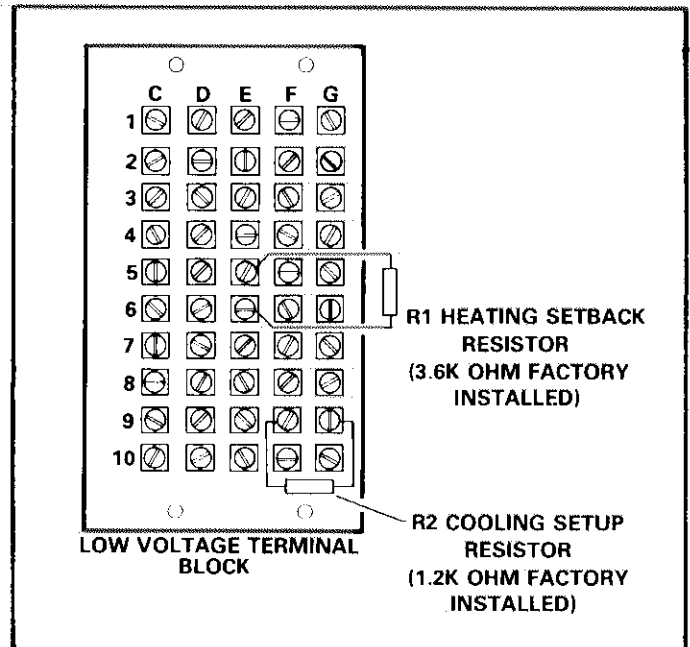

FIGURE 26

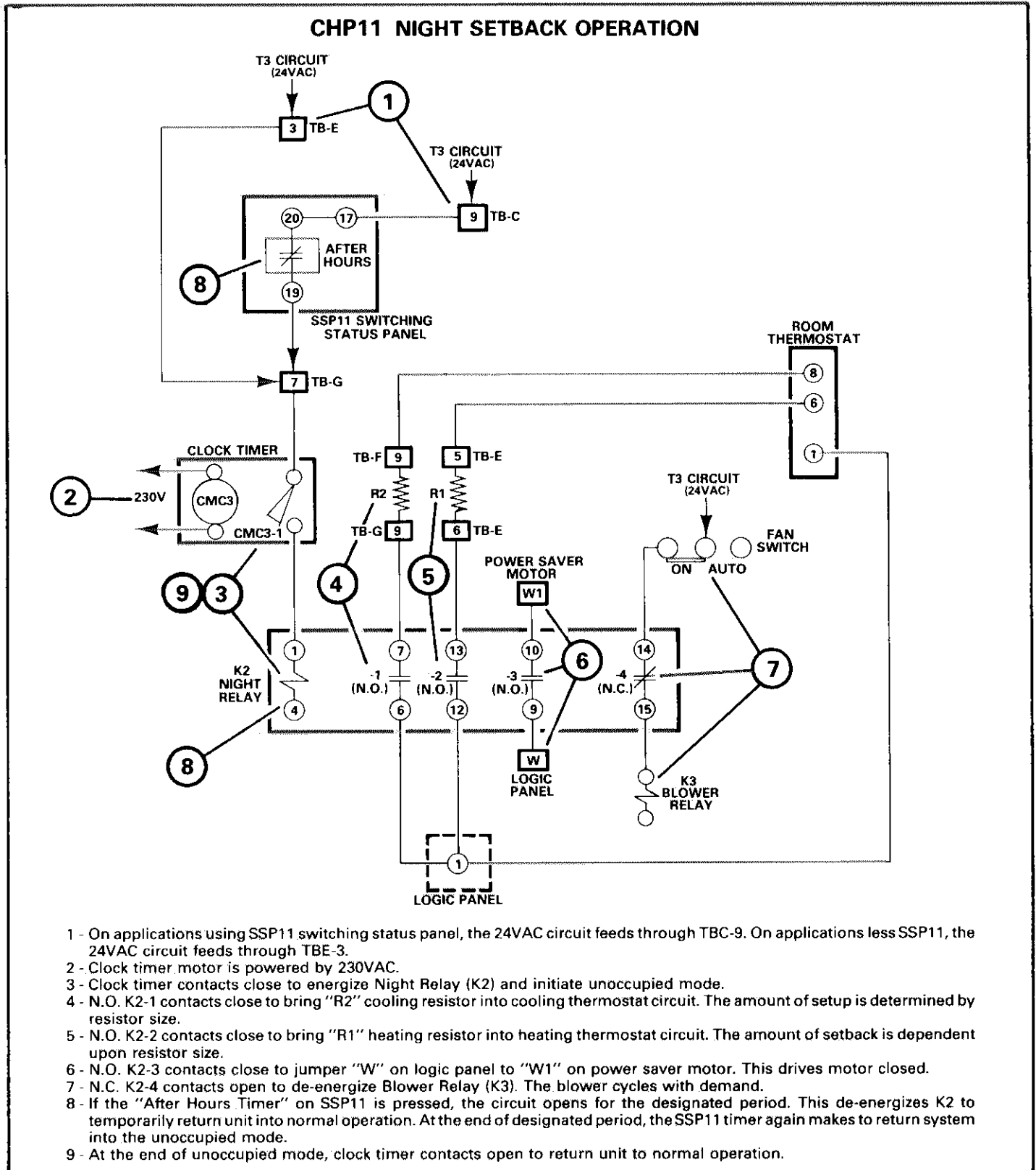

FIGURE 27

VIII - STATUS PANEL OPTIONS

The status panel allows remote monitoring of system operation. Two types of panels are available. The SP11 provides system readout only. The SSP11 switching status panel

combines the switching subbase and status panel functions together. In addition the SSP11 has a night setback override. Figures 28 and 29 show both panels.

1 - The "Cool Mode" LED is green when lit. It indicates Power

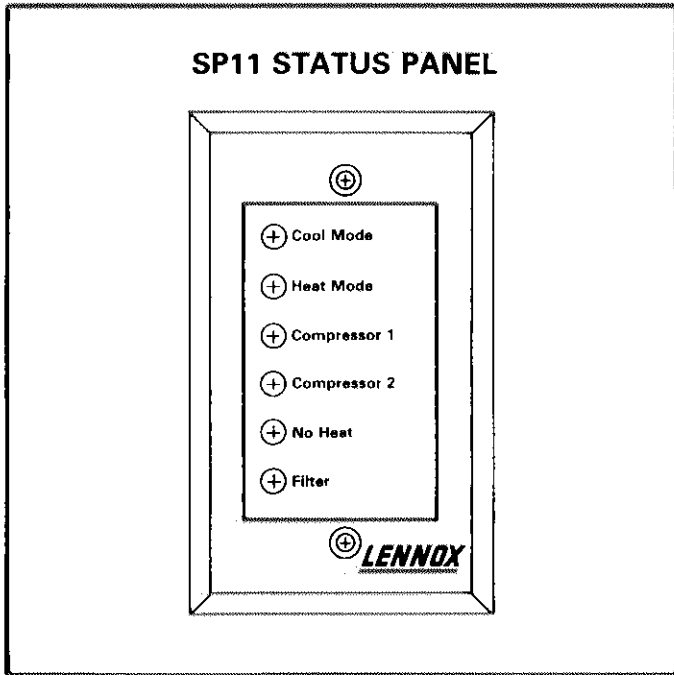

FIGURE 28

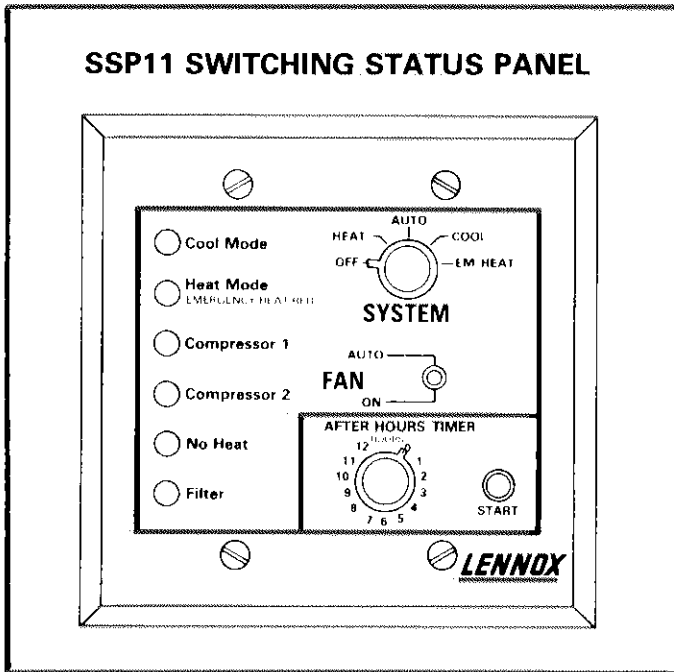

FIGURE 29

Saver operation when unit is so equipped. Otherwise the LED will indicate DX cooling operation.

- 2 - The "Heat Mode" LED lights green upon actuation of heating operation. This LED switches to red whenever the SSP11 system switch is placed into the Emergency Heat position.
- 3 - The "Compressor 1" and "Compressor 2" LED's are green when the respective compressors are running. Either light will turn red if a compressor safety switch opens during a compressor demand.
- 4 - The "No Heat" LED lights red on a loss of auxiliary heat. When applied to an ECH11 heater, a field installed current

sensing relay (K20) detects current flow to the first element. On hot water applications, a sensing circuit consisting of an electronic relay (K24), a sensing thermostat (S21) and a hot water delay (DL6) detects a no heat situation.

- 5 - The "Filter" LED will light red when the field installed filter pressure switch (S14) contacts close indicating a dirty filter.
- 6 - The "System" switch on the SSP11 has five positions to indicate the following modes:
 - OFF
 - HEAT
 - AUTO
 - COOL
 - EMERGENCY HEAT
- 7 - The "Fan" switch on the SSP11 has two positions to indicate the following modes:
 - AUTO
 - ON
- 8 - The "After Hours" timer on the SSP11 provides an override of night setback from 0 to 12 hours. A momentary push button switch initiates the time period.

IX - FIRESTATS

Some local codes may require the installation of supply air and return air firestats to automatically shut down the equipment at excessive temperatures. These field provided firestats must be mounted and wired per local codes. Manual reset type controls must be accessible. Figure 30 illustrates two suggested methods of wiring the firestats into the control circuit. When a firestat opens the control circuit is de-energized and the unit shuts down.

X - MAINTENANCE

A - Lubrication

Always relubricate motors according to manufacturer's lubrication instructions on each motor. If no instructions are provided, use the following as a guide:

- 1 - Indoor Blower Motor Bearings - Bearings are prelubricated. For extended bearing life, relubricate at least once every two years with a lithium base grease, such as Westinghouse 53701RW, Chevron BRB2 (Standard Oil) or Andok 260 (Exxon Oil). To relubricate, replace top plugs with standard grease fittings. Remove lower outlet plugs and add grease with handgun until new grease appears at bottom outlets. Run motor for a short time before replacing bottom plugs.
- 2 - Condenser Fan Motors - Bearings are prelubricated. For extended bearing life, relubricate at least once every two years with a lithium base grease, such as Alvanie 3 (Shell Oil), Chevron ABRB3 (Standard Oil) or Regal AFB 2 (Texas Oil). Use hand grease gun for relubrication. Add only enough grease to purge through the bearings so that a bead of grease appears at the seal lip contacts.

B - Filters

Inspect filters at least twice annually. Units equipped with optional status panel will indicate at the status panel when

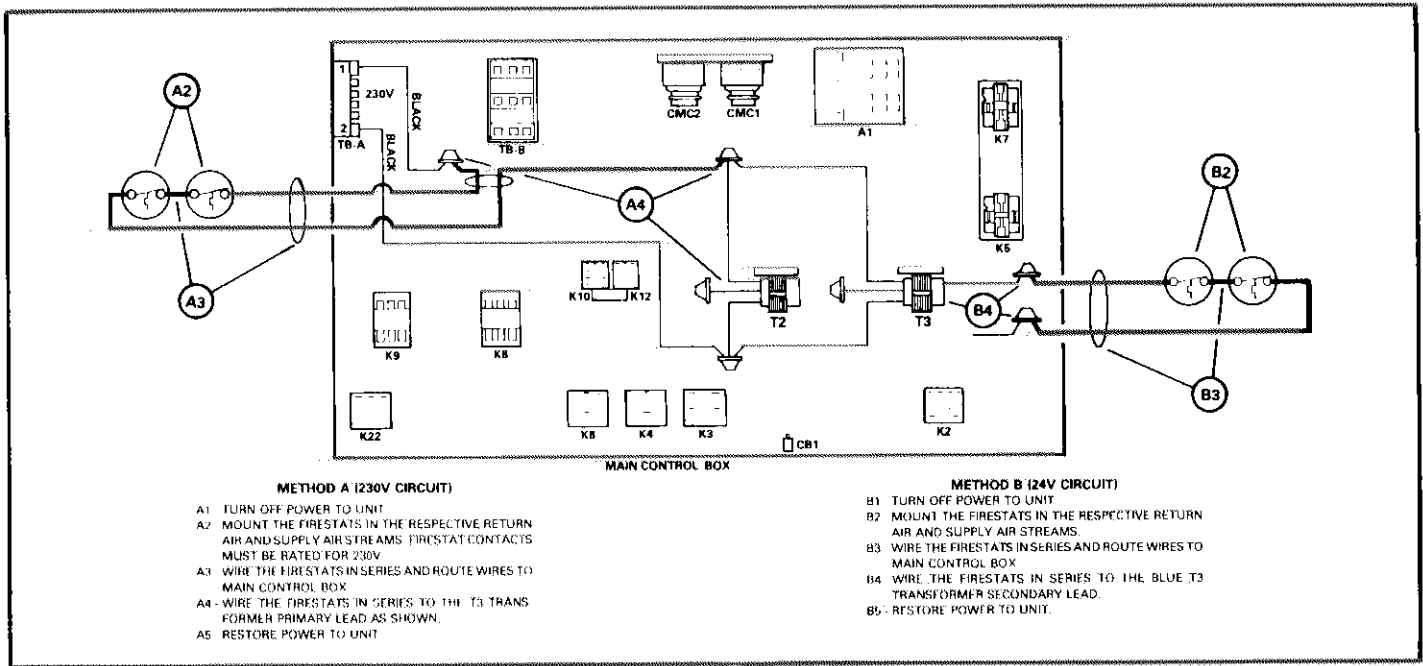

FIGURE 30

filters are dirty or plugged resulting in restricted air flow. Replace the 16 in. x 20 in. x 1 in. frame type filters with equivalent filters available from your Lennox dealer.

C - Outdoor Coil

Annually rinse the outdoor fin coil with water to remove dirt or other accumulation.

D - Compressor Oil Charge

CHP11-953 with Bristol compressors uses 65 oz. of the type Suniso 3GS per compressor.

CHP11-953 with Copeland compressors uses 60 oz. of heat pump grade mineral oil of 190 to 210 viscosity per compressor.

CHP11-1353 with Bristol compressors uses 65 oz. of the type Suniso 3GS per compressor.

CHP11-1353 with Copeland compressors uses 72 oz. of heat pump grade mineral oil of 190 to 210 viscosity per compressor.

XI - GENERAL SCHEMATIC INFORMATION

- 1 - The unit schematic wiring diagram format incorporates a horizontal power line which separates the line voltage circuit (motors-compressors-electric elements) from the controlling circuit. The motors, compressors and electric elements are located below the power line with the controlling circuit directly above the line.
- 2 - The graphic symbols for components and code lettering conforms to the "IEEE Standard and American National Standard" of graphic symbols for electrical diagrams. All symbols and code lettering used are approved by the International Electrotechnical Commission (IEC). Refer to Figure 31 for code and symbol identification.
- 3 - A component index chart is provided on each diagram

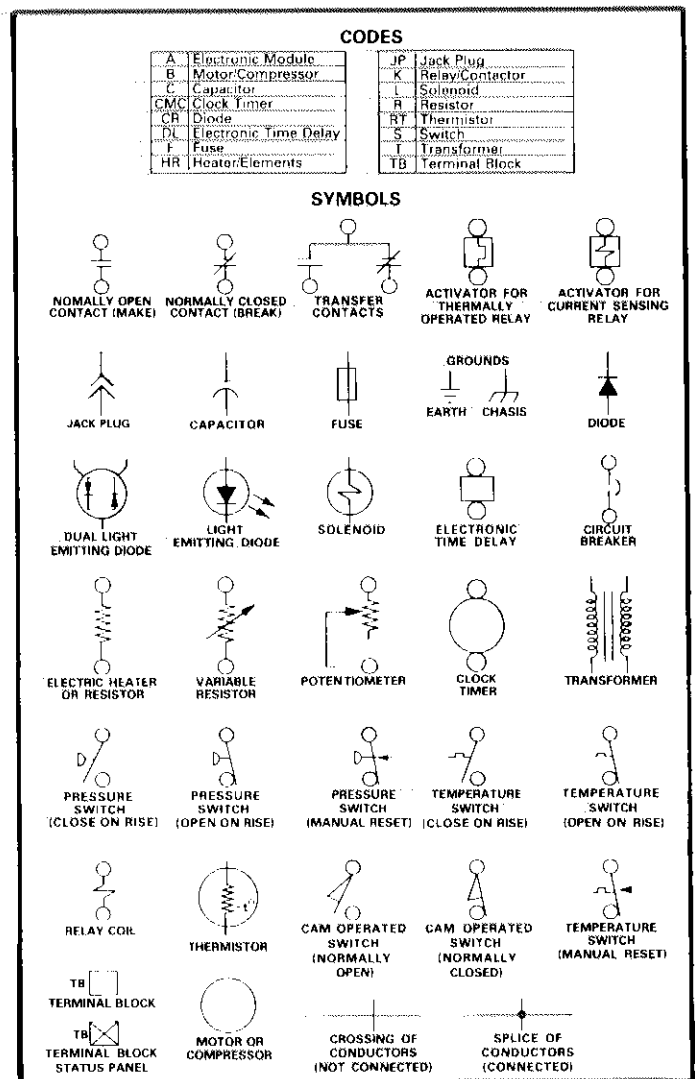

FIGURE 31

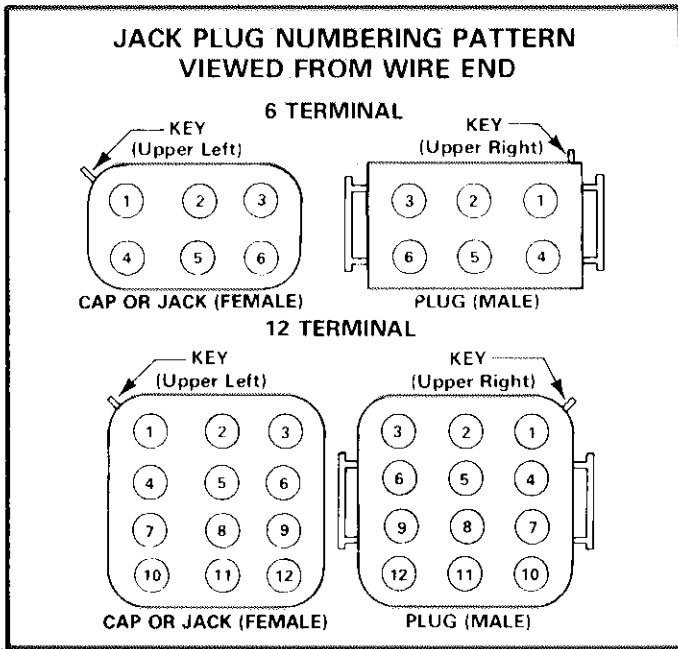

FIGURE 32

which includes -

- Code numbers (Key).
- Description of component.
- Location of component. See Example A in Figure 34.
- Cross reference to other diagram sections: See Example B in Figure 34.

- 4 - Terminal numbers on jack plugs are located by a ridge on the corner of the plug called the "Key." Refer to Figure 32 for proper numbering sequence.
- 5 - Jack plugs are shown in the schematic by both jack plug number and terminal number. In Example C of Figure 34, JP1-5 indicates jack plug number 1 and terminal number 5.
- 6 - Optional circuits are shown with arrow connections. In Example D, the remote minimum positioner (R4) is a substitute for the minimum positioner (R3) in unit.
- 7 - Solid lines around a control indicate a complete control — Example E. Dashed lines around a control indicates only a part of a control — Example F.

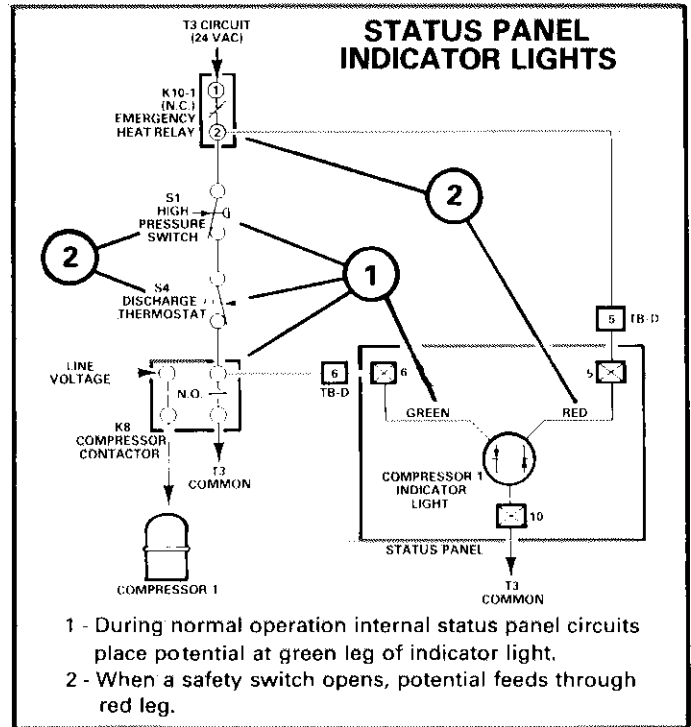

FIGURE 33

- 1 - During normal operation internal status panel circuits place potential at green leg of indicator light.
- 2 - When a safety switch opens, potential feeds through red leg.

- 8 - The "Compressor 1", "Compressor 2" and "Heat Mode" indicator lights used in the status panel options are dual color. Figure 33 illustrates "Compressor 1" light schematically. The light is green during a compressor demand but changes to red if a safety switch opens.

During normal operation internal status panel circuits place potential at the green leg of indicator light. When a compressor safety switch opens, potential feeds through the red leg.

- 9 - Pages 34 and 35 show a complete CHP11 unit schematic for an application including SSP11 switching Status Panel, Power Saver and ECH11 Electric Heat. Pages 36 and 37 show another CHP11 unit schematic with switching sub-base, SP11 Status Panel, Power Saver and ECH11 Electric Heat.

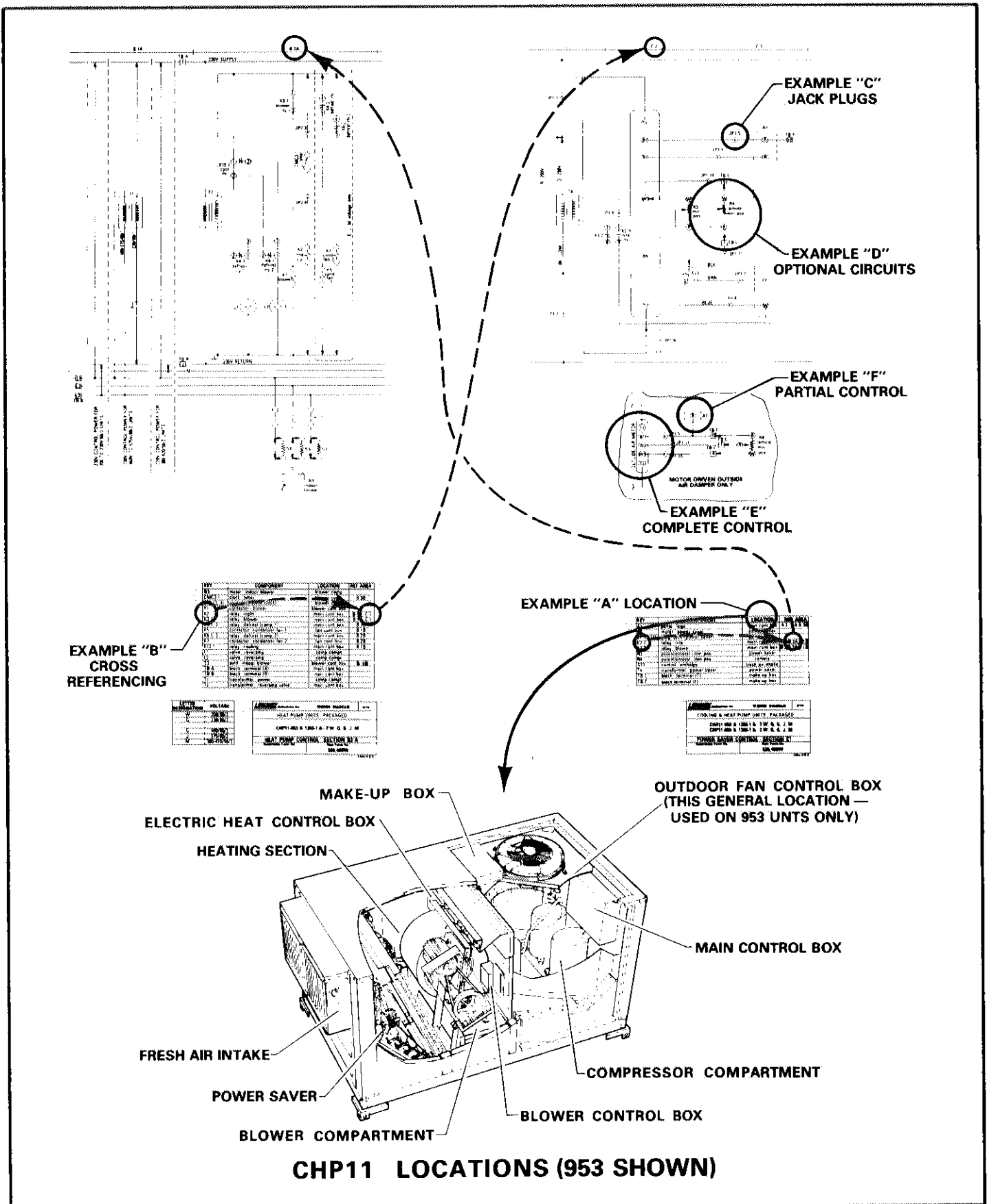
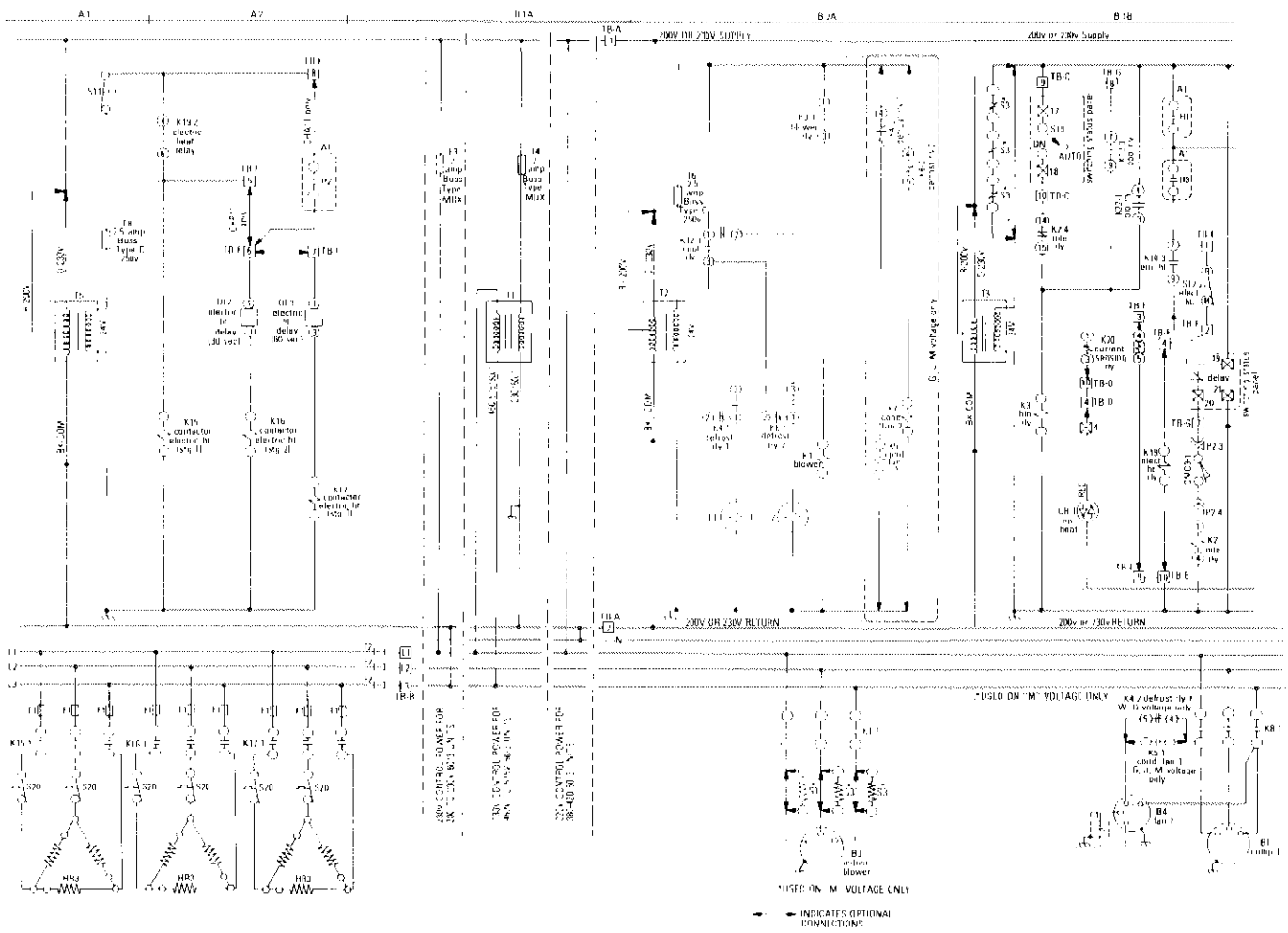

FIGURE 34



INDICATES OPTIONAL CONNECTIONS

KEY	COMPONENT	LOCATION	REF AREA
A1	panel base (HAT) only	main ctrl box	B 4 C 1
DV2	relay, electric heat (H) sec 1	electr hgt cont box	B 4 C 1
DA3	relay, electric heat (H) sec 2	electr hgt cont box	B 4 C 1
DL1	relay, electric heat	electr hgt cont box	B 4 C 1
D5	bus - copper/alum	h.v. jct box	
FB	fuse transformer	TK transformer	
HRS	electr. electric hgt	hgt sec box	
K15	contactor, electric heat 1	main hgt cont box	
K16	contactor, electric heat 2	main hgt cont box	
K17	contactor, electric heat 3	elect hgt cont box	
K18	relay, electric heat	hgt section	B 4 C 1 B
N11	unit, electric heat	hgt section	
CU0	condenser, electric heat	airman	
T5	transformer, electric heat	elect hgt cont box	
TR F	block, terminal (T)	h.v. jct box	

LETTER DESIGNATION	VOLTAGE
W	200/200
N	230/240

LENNOX WIRING DIAGRAM 790
 HEATING UNITS - ELECTRIC
 CHAFF 953 & 1353-B - 7 W. O
 CHP11 953 & 1353-B - 7 W. O
 ELECTRIC HEAT - SECTION A7 AS KW (optional)
 526 475W

KEY	COMPONENT	LOCATION	REF AREA
D1	motor, indoor blower	blower comp	
F2	fuse	main control box	
T4	transformer	T1 transformer	
FB	fuse transformer, outdoor valve	T2 transformer	
K1	contactor, blower	blower ctrl box	
K2	relay, blower	main ctrl box	B 1 B C 1
K3	relay, defrost (temp 1)	main ctrl box	B 1 B
K5	contactor, condenser fan 1	fan ctrl box	B 1 B
K6	relay, defrost (temp 2)	main ctrl box	B 1 B
K7	contactor, condenser fan 2	fan ctrl box	B 1 B
K12	relay, cooling	main ctrl box	B 1 B
T1	valve, reversing	comp control	
T2	valve, reversing	comp control	
TR	liquid outdoor blower	blower ctrl box	
TR A	block, terminal (A)	main ctrl box	B 1 B
TR B	block, terminal (B)	main ctrl box	
T3	transformer, power	comp control	
T7	transformer, reversing valve	main ctrl box	

LETTER DESIGNATION	VOLTAGE
W	200/200
N	230/240
G	400/500
S	575/600
M	360/450/560

LENNOX WIRING DIAGRAM 790
 HEAT PUMP UNITS - PARALLEL
 CHP11 953 & 1353-B - 2 W. O. G. J. M. - HW**
 **INDICATES HOT WATER HEAT UNIT
 HEAT PUMP CONTROL - SECTION B2-A
 526 408W

CHP11 WITH SSP11 SWITCHING STATUS PANEL, POWER SAVER AND ECH11 ELECTRIC HEAT

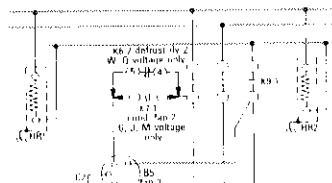
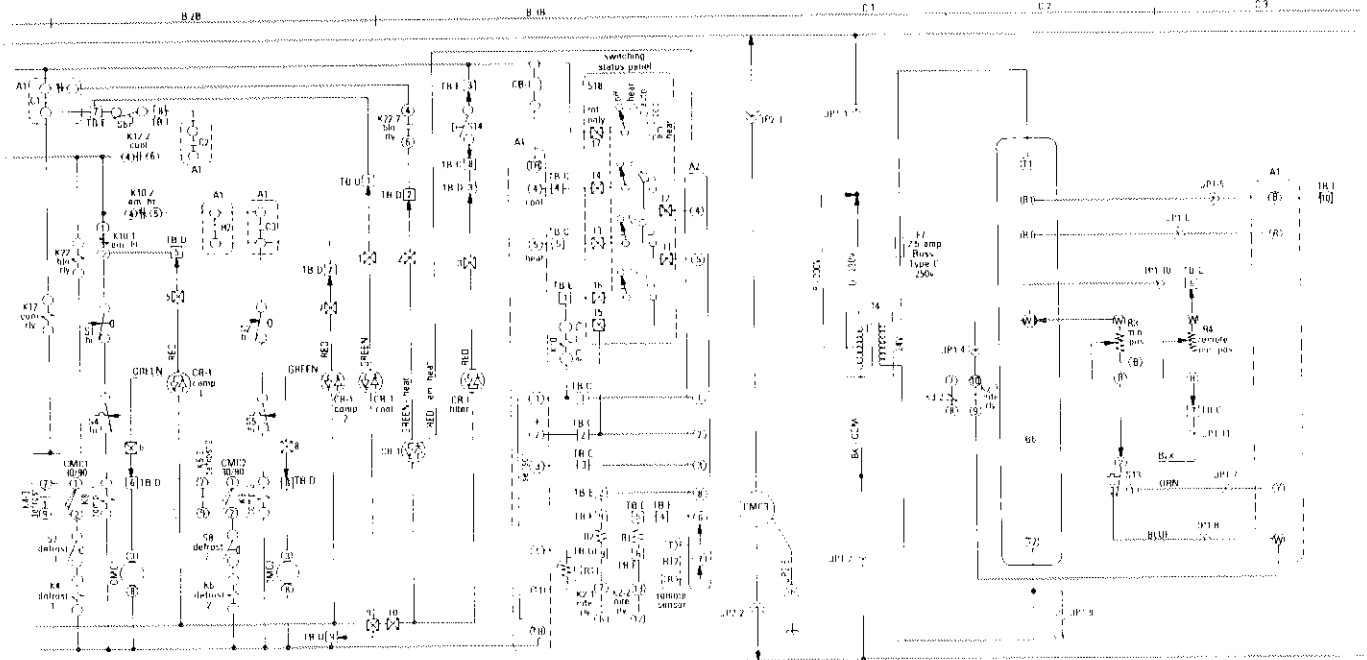

KEY	COMPONENT	LOCATION	REF. AREA
A1	panel lug	main control box	C1, B2
A2	electrical thermostat or transmitter	various	
B1, B2	compressor No. 1 & No. 2	comp. compartment	
BA, BS	motor condenser for No. 1 & No. 2	comp. compartment	
BT1, BT2	refrigerant condenser fan	comp. compartment	
CB1	breaker control	main control box	
CB2	acids high emitting	status panel	
CM1	low voltage defrost temp 11 30/30 min	main control box	
CM2	over defrost temp 21 30/30 min	main control box	
CM3	fan relay	main control box	
CR1, CR2	heater control for No. 1 & No. 2	compressor	
DP1, DP2	plug lock (lockdown)	blower compartment	
EV	relay safe	main control box	C1
F1	relay blow	main control box	H/A, C1, C2
F2	relay defrost temp 11	main control box	H/A
F3	relay defrost temp 21	main control box	H/A
F4	contactor condenser fan No. 1	fan condenser box	H/A
F5	relay defrost temp 21	main control box	H/A
F6	contactor condenser fan No. 2	fan condenser box	H/A
F7	contactor condenser fan No. 1	fan condenser box	H/A
F8	contactor compressor No. 1	main control box	
F9	contactor compressor No. 2	main control box	
F10	relay emergency heat	main control box	
F11	relay cooling	main control box	H/A
F12	relay electric heat	electrical control box	A1, A2
F13	relay fan blow	main control box	
F14	relay fan blow	main control box	
F15	relay fan blow	main control box	
F16	relay fan blow	main control box	
F17	relay fan blow	main control box	
F18	relay fan blow	main control box	
F19	relay fan blow	main control box	
F20	relay fan blow	main control box	
F21	relay fan blow	main control box	
F22	relay fan blow	main control box	
F23	relay fan blow	main control box	
F24	relay fan blow	main control box	
F25	relay fan blow	main control box	
F26	relay fan blow	main control box	
F27	relay fan blow	main control box	
F28	relay fan blow	main control box	
F29	relay fan blow	main control box	
F30	relay fan blow	main control box	
F31	relay fan blow	main control box	
F32	relay fan blow	main control box	
F33	relay fan blow	main control box	
F34	relay fan blow	main control box	
F35	relay fan blow	main control box	
F36	relay fan blow	main control box	
F37	relay fan blow	main control box	
F38	relay fan blow	main control box	
F39	relay fan blow	main control box	
F40	relay fan blow	main control box	
F41	relay fan blow	main control box	
F42	relay fan blow	main control box	
F43	relay fan blow	main control box	
F44	relay fan blow	main control box	
F45	relay fan blow	main control box	
F46	relay fan blow	main control box	
F47	relay fan blow	main control box	
F48	relay fan blow	main control box	
F49	relay fan blow	main control box	
F50	relay fan blow	main control box	
F51	relay fan blow	main control box	
F52	relay fan blow	main control box	
F53	relay fan blow	main control box	
F54	relay fan blow	main control box	
F55	relay fan blow	main control box	
F56	relay fan blow	main control box	
F57	relay fan blow	main control box	
F58	relay fan blow	main control box	
F59	relay fan blow	main control box	
F60	relay fan blow	main control box	
F61	relay fan blow	main control box	
F62	relay fan blow	main control box	
F63	relay fan blow	main control box	
F64	relay fan blow	main control box	
F65	relay fan blow	main control box	
F66	relay fan blow	main control box	
F67	relay fan blow	main control box	
F68	relay fan blow	main control box	
F69	relay fan blow	main control box	
F70	relay fan blow	main control box	
F71	relay fan blow	main control box	
F72	relay fan blow	main control box	
F73	relay fan blow	main control box	
F74	relay fan blow	main control box	
F75	relay fan blow	main control box	
F76	relay fan blow	main control box	
F77	relay fan blow	main control box	
F78	relay fan blow	main control box	
F79	relay fan blow	main control box	
F80	relay fan blow	main control box	
F81	relay fan blow	main control box	
F82	relay fan blow	main control box	
F83	relay fan blow	main control box	
F84	relay fan blow	main control box	
F85	relay fan blow	main control box	
F86	relay fan blow	main control box	
F87	relay fan blow	main control box	
F88	relay fan blow	main control box	
F89	relay fan blow	main control box	
F90	relay fan blow	main control box	
F91	relay fan blow	main control box	
F92	relay fan blow	main control box	
F93	relay fan blow	main control box	
F94	relay fan blow	main control box	
F95	relay fan blow	main control box	
F96	relay fan blow	main control box	
F97	relay fan blow	main control box	
F98	relay fan blow	main control box	
F99	relay fan blow	main control box	
F100	relay fan blow	main control box	

TERMINAL BLOCK
STATUS PANEL

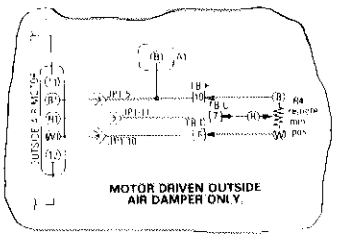

INDICATES OPTIONAL CONNECTIONS

KEY	COMPONENT	LOCATION	REF. AREA
20	control relay	main control box	A, B, C, D, E, F, G, H, I, J, K, L, M, N, O, P, Q, R, S, T, U, V, W, X, Y, Z
21	control relay	main control box	A, B, C, D, E, F, G, H, I, J, K, L, M, N, O, P, Q, R, S, T, U, V, W, X, Y, Z
22	control relay	main control box	A, B, C, D, E, F, G, H, I, J, K, L, M, N, O, P, Q, R, S, T, U, V, W, X, Y, Z
23	control relay	main control box	A, B, C, D, E, F, G, H, I, J, K, L, M, N, O, P, Q, R, S, T, U, V, W, X, Y, Z
24	control relay	main control box	A, B, C, D, E, F, G, H, I, J, K, L, M, N, O, P, Q, R, S, T, U, V, W, X, Y, Z
25	control relay	main control box	A, B, C, D, E, F, G, H, I, J, K, L, M, N, O, P, Q, R, S, T, U, V, W, X, Y, Z
26	control relay	main control box	A, B, C, D, E, F, G, H, I, J, K, L, M, N, O, P, Q, R, S, T, U, V, W, X, Y, Z
27	control relay	main control box	A, B, C, D, E, F, G, H, I, J, K, L, M, N, O, P, Q, R, S, T, U, V, W, X, Y, Z
28	control relay	main control box	A, B, C, D, E, F, G, H, I, J, K, L, M, N, O, P, Q, R, S, T, U, V, W, X, Y, Z
29	control relay	main control box	A, B, C, D, E, F, G, H, I, J, K, L, M, N, O, P, Q, R, S, T, U, V, W, X, Y, Z
30	control relay	main control box	A, B, C, D, E, F, G, H, I, J, K, L, M, N, O, P, Q, R, S, T, U, V, W, X, Y, Z
31	control relay	main control box	A, B, C, D, E, F, G, H, I, J, K, L, M, N, O, P, Q, R, S, T, U, V, W, X, Y, Z
32	control relay	main control box	A, B, C, D, E, F, G, H, I, J, K, L, M, N, O, P, Q, R, S, T, U, V, W, X, Y, Z
33	control relay	main control box	A, B, C, D, E, F, G, H, I, J, K, L, M, N, O, P, Q, R, S, T, U, V, W, X, Y, Z
34	control relay	main control box	A, B, C, D, E, F, G, H, I, J, K, L, M, N, O, P, Q, R, S, T, U, V, W, X, Y, Z
35	control relay	main control box	A, B, C, D, E, F, G, H, I, J, K, L, M, N, O, P, Q, R, S, T, U, V, W, X, Y, Z
36	control relay	main control box	A, B, C, D, E, F, G, H, I, J, K, L, M, N, O, P, Q, R, S, T, U, V, W, X, Y, Z
37	control relay	main control box	A, B, C, D, E, F, G, H, I, J, K, L, M, N, O, P, Q, R, S, T, U, V, W, X, Y, Z
38	control relay	main control box	A, B, C, D, E, F, G, H, I, J, K, L, M, N, O, P, Q, R, S, T, U, V, W, X, Y, Z
39	control relay	main control box	A, B, C, D, E, F, G, H, I, J, K, L, M, N, O, P, Q, R, S, T, U, V, W, X, Y, Z
40	control relay	main control box	A, B, C, D, E, F, G, H, I, J, K, L, M, N, O, P, Q, R, S, T, U, V, W, X, Y, Z
41	control relay	main control box	A, B, C, D, E, F, G, H, I, J, K, L, M, N, O, P, Q, R, S, T, U, V, W, X, Y, Z
42	control relay	main control box	A, B, C, D, E, F, G, H, I, J, K, L, M, N, O, P, Q, R, S, T, U, V, W, X, Y, Z
43	control relay	main control box	A, B, C, D, E, F, G, H, I, J, K, L, M, N, O, P, Q, R, S, T, U, V, W, X, Y, Z
44	control relay	main control box	A, B, C, D, E, F, G, H, I, J, K, L, M, N, O, P, Q, R, S, T, U, V, W, X, Y, Z
45	control relay	main control box	A, B, C, D, E, F, G, H, I, J, K, L, M, N, O, P, Q, R, S, T, U, V, W, X, Y, Z
46	control relay	main control box	A, B, C, D, E, F, G, H, I, J, K, L, M, N, O, P, Q, R, S, T, U, V, W, X, Y, Z
47	control relay	main control box	A, B, C, D, E, F, G, H, I, J, K, L, M, N, O, P, Q, R, S, T, U, V, W, X, Y, Z
48	control relay	main control box	A, B, C, D, E, F, G, H, I, J, K, L, M, N, O, P, Q, R, S, T, U, V, W, X, Y, Z
49	control relay	main control box	A, B, C, D, E, F, G, H, I, J, K, L, M, N, O, P, Q, R, S, T, U, V, W, X, Y, Z
50	control relay	main control box	A, B, C, D, E, F, G, H, I, J, K, L, M, N, O, P, Q, R, S, T, U, V, W, X, Y, Z

LENNDY WIRING DIAGRAM 7/80

HEAT PUMP UNIT'S PACKAGE

CHP11 953 & 1363 I & 2 W. O. G. J. M.

(WITH SWITCHING STATUS PANEL, SSP11)

HEAT PUMP CONTROL - SECTION B2-B

526.719W

LENNDY WIRING DIAGRAM 7/80

ALCO'S DIRECTS

CHP11 953 & 1363 I & 2 W. O. G. J. M. RW**

CHP11 953 & 1363 I & 2 W. O. G. J. M. RW**

** DENOTES DEL. W/TH HEAT UNIT

POWER SAVER CONTROL - SECTION C1 (optional)

326.609W

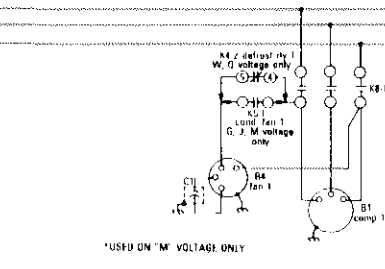
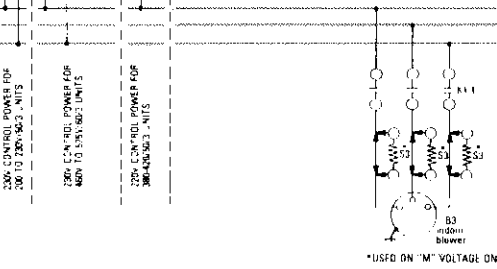
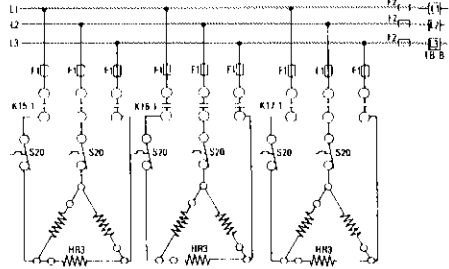
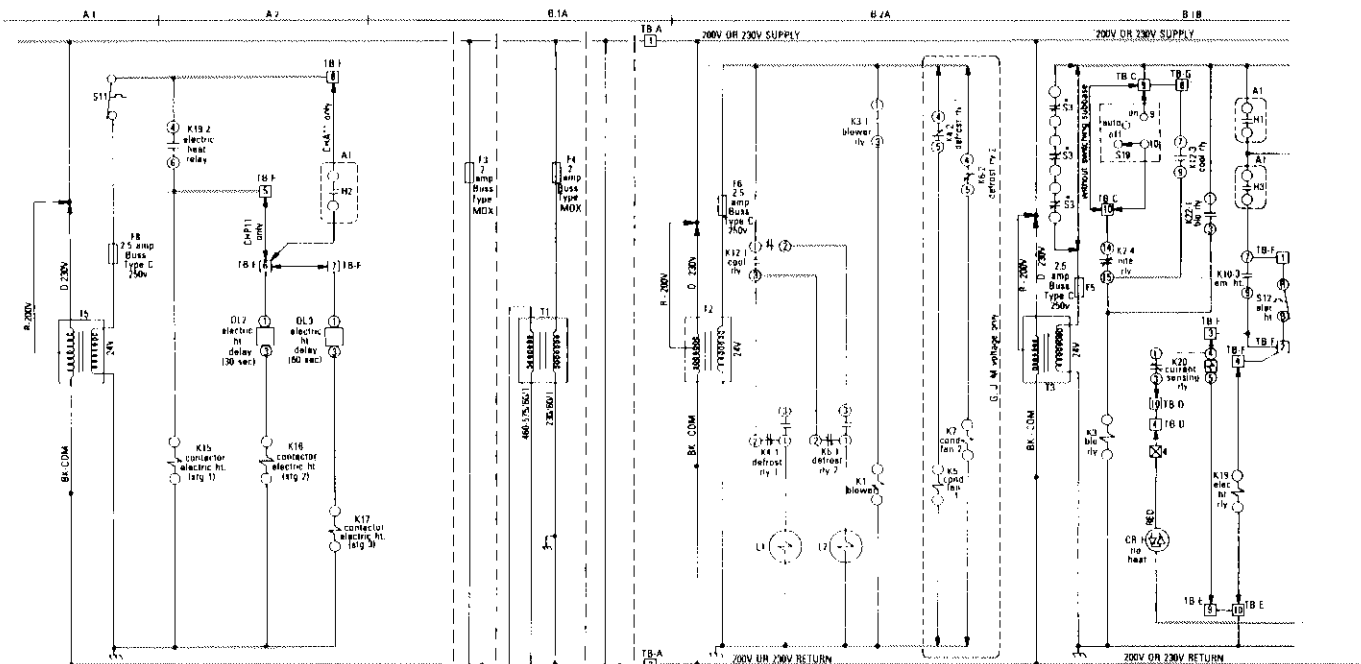

INDICATES OPTIONAL CONNECTIONS

KEY	COMPONENT	LOCATION	REF AREA
A1	panel logic (CHA11 only)	main cont box	B 4, C 3
DT2	delay electric heat (30 sec)	elec hq cont box	
DT3	delay electric heat (60 sec)	elec hq cont box	
F1	fuse electric heat	elec hq cont box	
F2	fuse compressor	n.v. jct box	
F3	fuse transformer	TS transformer	
H1	element electric hq	hig section	
K13	contactor electric heat	elec hq cont box	
K14	contactor electric heat	elec hq cont box	
K15	contactor electric heat	elec hq cont box	
K16	contactor electric heat	elec hq cont box	
K17	contactor electric heat	elec hq cont box	
K18	contactor electric heat	elec hq cont box	
K19	contactor electric heat	elec hq cont box	
K20	contactor electric heat	elec hq cont box	
K21	contactor electric heat	elec hq cont box	
K22	contactor electric heat	elec hq cont box	
K23	contactor electric heat	elec hq cont box	
K24	contactor electric heat	elec hq cont box	
K25	contactor electric heat	elec hq cont box	
K26	contactor electric heat	elec hq cont box	
K27	contactor electric heat	elec hq cont box	
K28	contactor electric heat	elec hq cont box	
K29	contactor electric heat	elec hq cont box	
K30	contactor electric heat	elec hq cont box	
K31	contactor electric heat	elec hq cont box	
K32	contactor electric heat	elec hq cont box	
K33	contactor electric heat	elec hq cont box	
K34	contactor electric heat	elec hq cont box	
K35	contactor electric heat	elec hq cont box	
K36	contactor electric heat	elec hq cont box	
K37	contactor electric heat	elec hq cont box	
K38	contactor electric heat	elec hq cont box	
K39	contactor electric heat	elec hq cont box	
K40	contactor electric heat	elec hq cont box	
K41	contactor electric heat	elec hq cont box	
K42	contactor electric heat	elec hq cont box	
K43	contactor electric heat	elec hq cont box	
K44	contactor electric heat	elec hq cont box	
K45	contactor electric heat	elec hq cont box	
K46	contactor electric heat	elec hq cont box	
K47	contactor electric heat	elec hq cont box	
K48	contactor electric heat	elec hq cont box	
K49	contactor electric heat	elec hq cont box	
K50	contactor electric heat	elec hq cont box	
K51	contactor electric heat	elec hq cont box	
K52	contactor electric heat	elec hq cont box	
K53	contactor electric heat	elec hq cont box	
K54	contactor electric heat	elec hq cont box	
K55	contactor electric heat	elec hq cont box	
K56	contactor electric heat	elec hq cont box	
K57	contactor electric heat	elec hq cont box	
K58	contactor electric heat	elec hq cont box	
K59	contactor electric heat	elec hq cont box	
K60	contactor electric heat	elec hq cont box	
K61	contactor electric heat	elec hq cont box	
K62	contactor electric heat	elec hq cont box	
K63	contactor electric heat	elec hq cont box	
K64	contactor electric heat	elec hq cont box	
K65	contactor electric heat	elec hq cont box	
K66	contactor electric heat	elec hq cont box	
K67	contactor electric heat	elec hq cont box	
K68	contactor electric heat	elec hq cont box	
K69	contactor electric heat	elec hq cont box	
K70	contactor electric heat	elec hq cont box	
K71	contactor electric heat	elec hq cont box	
K72	contactor electric heat	elec hq cont box	
K73	contactor electric heat	elec hq cont box	
K74	contactor electric heat	elec hq cont box	
K75	contactor electric heat	elec hq cont box	
K76	contactor electric heat	elec hq cont box	
K77	contactor electric heat	elec hq cont box	
K78	contactor electric heat	elec hq cont box	
K79	contactor electric heat	elec hq cont box	
K80	contactor electric heat	elec hq cont box	
K81	contactor electric heat	elec hq cont box	
K82	contactor electric heat	elec hq cont box	
K83	contactor electric heat	elec hq cont box	
K84	contactor electric heat	elec hq cont box	
K85	contactor electric heat	elec hq cont box	
K86	contactor electric heat	elec hq cont box	
K87	contactor electric heat	elec hq cont box	
K88	contactor electric heat	elec hq cont box	
K89	contactor electric heat	elec hq cont box	
K90	contactor electric heat	elec hq cont box	
K91	contactor electric heat	elec hq cont box	
K92	contactor electric heat	elec hq cont box	
K93	contactor electric heat	elec hq cont box	
K94	contactor electric heat	elec hq cont box	
K95	contactor electric heat	elec hq cont box	
K96	contactor electric heat	elec hq cont box	
K97	contactor electric heat	elec hq cont box	
K98	contactor electric heat	elec hq cont box	
K99	contactor electric heat	elec hq cont box	
K100	contactor electric heat	elec hq cont box	

LETTER DESIGNATION	VOLTAGE
W	200/230
G	230/260
C	480/500
M	575/600

LETTER DESIGNATION	VOLTAGE
W	200/230
G	230/260
C	480/500
M	575/600

LETTER DESIGNATION	VOLTAGE
W	200/230
G	230/260
C	480/500
M	575/600

LENING WIRING DIAGRAM 700

HEATING UNITS - ELECTRIC

CHA11-MS & 1353-1 & 2 W. D. C. J. M. HW**

CHP11-MS & 1353-1 & 2 W. D. C. J. M. HW**

ELECTRIC HEAT SECTION A7 45 KW (optional)

524 475W

LENING WIRING DIAGRAM 700

HEAT PUMP UNITS - PACKAGED

CHP11-MS & 1353-1 & 2 W. D. C. J. M. HW**

** INDICATES HOT WATER HEAT UNIT

HEAT PUMP CONTROL SECTION B2-A

526 400W

CHP11 WITH SWITCHING SUBBASE, SP11 STATUS PANEL, POWER SAVER AND ECH11 ELECTRIC HEAT

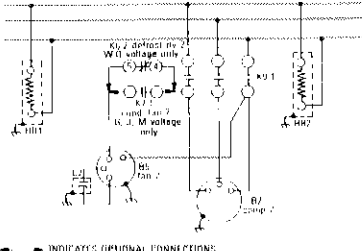
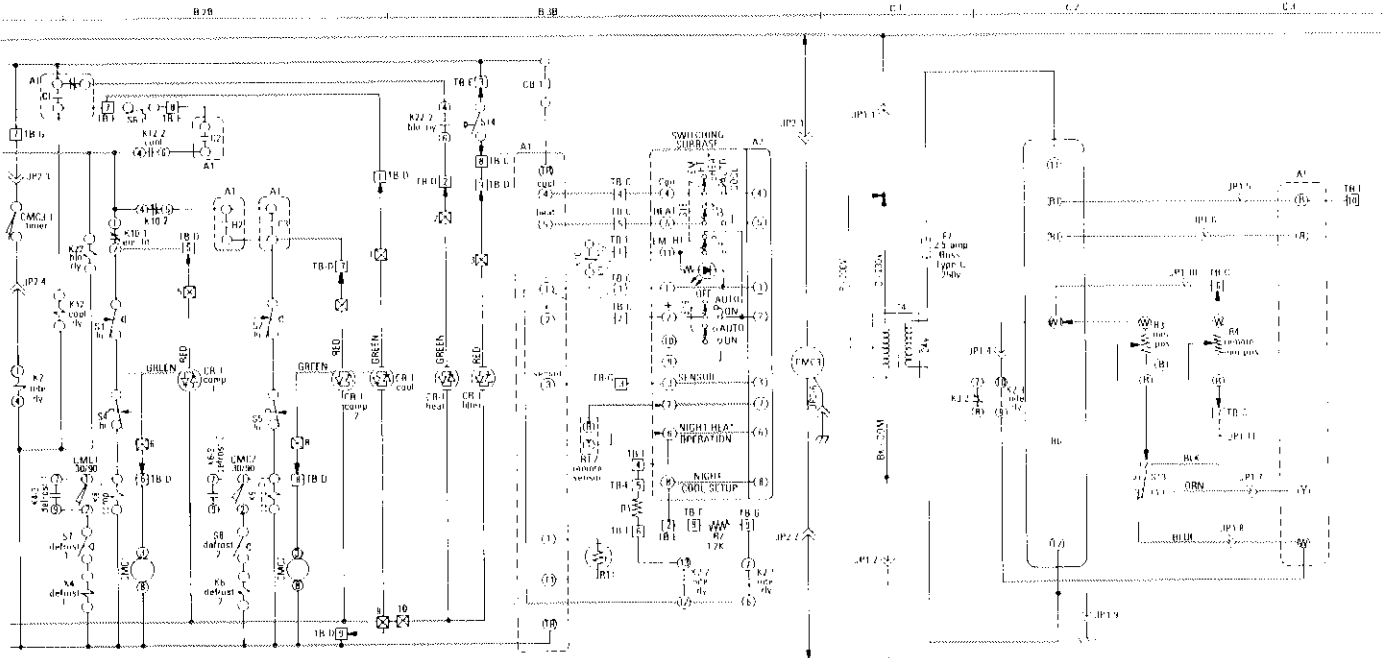

KEY	COMPONENT	LOCATION	REF AREA
A1	alarm light	main cont box	C1, D1
A2	control thermostat or transmitter	remote	
B1	compressor No. 1 & No. 2	main cont box	
B4, B5	motor condenser fan No. 1 & No. 2	comp comp	
C1, C2	capacitor condenser fan	comp comp	
CB1	breaker control	main cont box	
CR1	drobe light emitting	status panel	
CMC1	timer defrost (comp 1) 3000 min	main cont box	
CMC2	timer defrost (comp 2) 3000 min	main cont box	
CMC3	timer lock	blower cabinet	
FB	base transformer control	compressor	
H1, H2	heater, cartridge No. 1 & No. 2	compressor	
JP11, 4	blow-off (black limit)	blower cabinet	
K2	relay night	main cont box	B2, C1
K3	relay alarm	main cont box	B2, C1
K4	relay defrost (comp 1)	main cont box	B2, A
K5	contactor condenser fan No. 1	fan condenser box	B2, A
K6	relay defrost (comp 2)	main cont box	B2, A
K7	contactor condenser fan No. 2	fan condenser box	B2, A
K8	contactor compressor No. 1	main cont box	
K9	contactor compressor No. 2	main cont box	
K10	relay emergency heat	main cont box	
K12	relay outdoor	main cont box	H2, A
K13	relay electric heat	electric heat box	A1, A2
K15	relay current sensing	main cont box	
K17	relay outdoor	main cont box	
R1	resistor night/day operation	1 v jct box	
R2	resistor night coil setup	1 v jct box	
RT1	resistor discharge	blower comp	
RT2	resistor room or return air	remote	
S1	switch high pressure (comp 1)	comp comp	
S2	switch high pressure (comp 2)	comp comp	
S3	W/E indoor blower	blower cont box	B2, A
S4	thermostat high limit (comp 1)	comp comp	
S5	thermostat high limit (comp 2)	comp comp	
S6	thermostat cooling lockout	1 v jct box	
S7	switch pressure defrost (comp 1)	comp comp	
S8	switch pressure defrost (comp 2)	comp comp	
S9	switch outdoor electric heat	1 v jct box	
S14	switch lift	blower comp	
S18	switch system	switching subbase	
S19	switch fan	1 v jct box	
TB C	block terminal (C)	1 v jct box	
TB D	block terminal (D)	1 v jct box	
TB E	block terminal (E)	1 v jct box	
TB F	block terminal (F)	1 v jct box	
TB G	block terminal (G)	1 v jct box	
T9	transformer control	main cont box	

TERMINAL BLOCK STATUS PANEL

LENKOP WIRING DIAGRAM 1/80

HEAT PUMP UNIT PACKAGE

CHP11-953 & 1353-1 & 2 W. O. G. J. M.

WITH STATUS PANEL, SP11

HEAT PUMP CONTROL - SECTION B2-B

526.720W

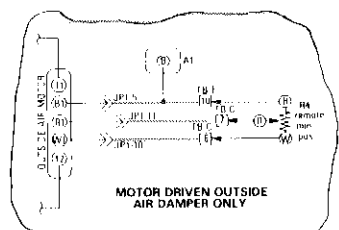

INDICATES OPTIONAL CONNECTIONS

KEY	COMPONENT	LOCATION	REF AREA
A1	alarm light	main cont box	A, 7, 8, 4, B, 3, D, 7
B1	motor condenser fan	POWER SAVER	
B2	base transformer power saver	14 transformer	
JP11, 12	plug jack power saver	POWER SAVER	
K1	relay lift	main cont box	B2, B, B
K2	relay blow-off	main cont box	B2, B, B, B, B
K3	pressure switch	POWER SAVER	
K4	control thermostat	remote	
K12	control thermostat	HEAT PUMP	
K15	control thermostat	POWER SAVER	
K16	control thermostat	1 v jct box	
T9	block terminal (F)	1 v jct box	
T9	block terminal (F)	1 v jct box	

LENKOP WIRING DIAGRAM 1/80

ACCESSORIES

CHP11-953 & 1353-1 & 2 W. O. G. J. M. HW**

CHP11-953 & 1353-1 & 2 W. O. G. J. M. HW**

DESIGNATES HOT WATER HEAT UNIT

POWER SAVER CONTROL SECTION C1 (optional)

526.400W

XII - SCHEMATIC WIRING DIAGRAM OPERATING SEQUENCE

Each of the following steps within this section are labeled in the corresponding diagram.

A - Cooling Mode (Figure 35)

- 1 - The Blower Relay K3 is energized continuously unless the optional switching subbase is set to "auto" or the Night Relay K2 is activated by the night setback option.
- 2 - The logic panel modulates power saver in response to input from the room thermostat & discharge sensor and setting of enthalpy control. K3 must be energized before power saver motor will open. See step 8.
- 3 - A cooling command signal of approximately 5V dc closes "C1" at logic panel.
- 4 - This energizes the Cooling Relay (K12) through the T3 transformer.
- 5 - As the N.O. K12-1 contact closes, both reversing valves (L1 & L2) are energized through the respective defrost relays N.C. K4-1 and N.C. K6-1. This circuit is powered by T2 transformer.
- 6 - As the N.O. K12-2 contact closes, the Blower Relay (K3) is energized through the T3 transformer.
Note - The K3 relay is only de-energized when the optional switching subbase is placed in "auto" or the night setback option is activated.
- 7 - The N.O. K3-1 contacts then energize the Indoor Blower Contactor (K1) to consequently energize the indoor blower motor.
- 8 - N.C. K3-2 contact opens to break the "W" to "W1" circuit between Logic Panel and Power Saver Motor B6 to allow normal operation of Power Saver circuit. The motor drives closed whenever this leg is closed.
- 9 - "C1" also energizes another circuit to "C2" through Cooling Lockout Thermostat (S6). This switch opens at a temperature drop below setting and automatically resets. S6 is factory set at 55°F.
- 10 - A cooling command signal of approximately 6.75V dc closes "C2" at logic panel.
- 11 - This energizes the No. 1 Compressor Contactor (K8) through:
 - N.O. K12-2 (energized in step 3)
 - N.C. K10-1 Emergency Heat Relay
 - S1-Hi Pressure Switch (manual reset)
 - S4 - Discharge Temperature Limit (manual reset)
- 12 - K8-1 contacts close to energize both the No. 1 compressor and condenser fan.
- 13 - "C2" also energizes a circuit to "C3" through K12-2 and K10-2.
- 14 - A cooling command signal of approximately 8.5V dc closes "C3" at logic panel.
- 15 - This energizes the No. 2 Compressor Contactor (K9) through:
 - S2 - Hi Pressure Switch (manual reset)
 - S5 - Discharge Temperature Limit (manual reset)
- 16 - K9-1 contacts close to energize both the No. 2 compressor and condenser fan.
- 17 - The logic panel opens the "C" switches in reverse order according to cooling command signal:
 - C3 opens at approximately 7.5V dc
 - C2 opens at approximately 5.75V dc
 - C1 opens at approximately 4V dc

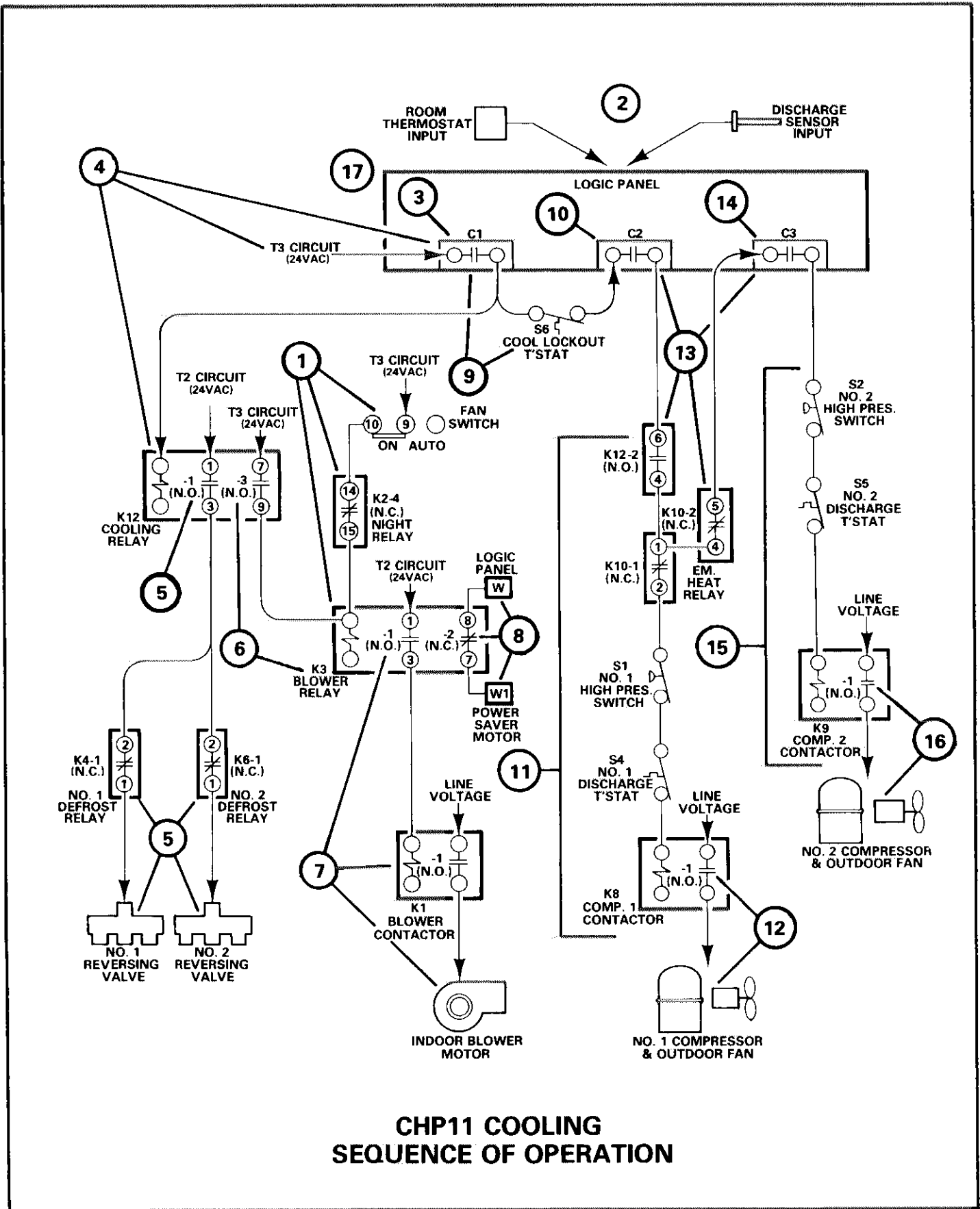

**CHP11 COOLING
SEQUENCE OF OPERATION**

FIGURE 35

B - Heating Mode (Figure 36)

- 1 - The Blower Relay K3 is energized continuously unless the optional switching subbase is set to "auto" or the Night Relay K2 is activated by the night setback option.
- 2 - The logic panel switches its contacts in response to the input of both the room thermostat and discharge sensor.
- 3 - A heating command signal of approximately 5V dc closes "H1" at logic panel.
- 4 - This energizes the Auto Blower Relay (K22) through the T3 transformer.
- 5 - As the N.O. K22-1 contact closes, the Blower Relay (K3) is energized through the T3 transformer.
Note - The K3 relay is only de-energized when the optional switching subbase is placed in "auto" or the night setback option is activated.
- 6 - The N.O. K3-1 contacts then energize the Indoor Blower Contactor (K1) to consequently energize the indoor blower motor.
- 7 - "H1" also energizes the No. 1 Compressor Contactor (K8) through:
N.C. K10-1 Emergency Heat Relay
S1 - Hi Pressure Switch (manual reset)
S4 - Discharge Temperature Limit (manual reset)
- 8 - K8-1 contacts close to energize both the No. 1 compressor and condenser fan.
- 9 - "H1" energizes another circuit to "H2" through N.C. K10-2.
- 10 - A heating command signal of approximately 6.75V dc closes "H2" at logic panel.
- 11 - This energizes the No. 2 Compressor Contactor (K9) through:
S2 - Hi Pressure Switch (manual reset)
S5 - Discharge Temperature Limit (manual reset)
- 12 - K9-1 contacts close to power both the No. 2 compressor and condenser fan.
Note - The following steps are for units incorporating electric heat. On hot water applications, the logic panel directly modulates hot water valve in response to heating signal.
- 13 - "H1" also powers another circuit to "H3". A heating command signal of 8.5V dc closes "H3".
- 14 - This energizes the Electric Heat Relay (K19) through the Outdoor Electric Heat Limit (S12). This switch is adjustable and locks out all electric heat with ambient temperatures above setting.
- 15 - N.O. K19-1 contacts power the No. 1 Electric Heat Contactor (K15) through the T5 transformer and the Electric Heat Limit (S11). S11 opens at a discharge temperature above setpoint.
- 16 - N.O. K15-1 contacts close to energize the first stage of elements.
- 17 - K19-1 also powers the additional stages of electric heat through time delays.
- 18 - The logic panel opens the "H" switches in reverse order according to heating command signal:
H3 opens at approximately 7.5Vdc
H2 opens at approximately 5.75V dc
H1 opens at approximately 4V dc

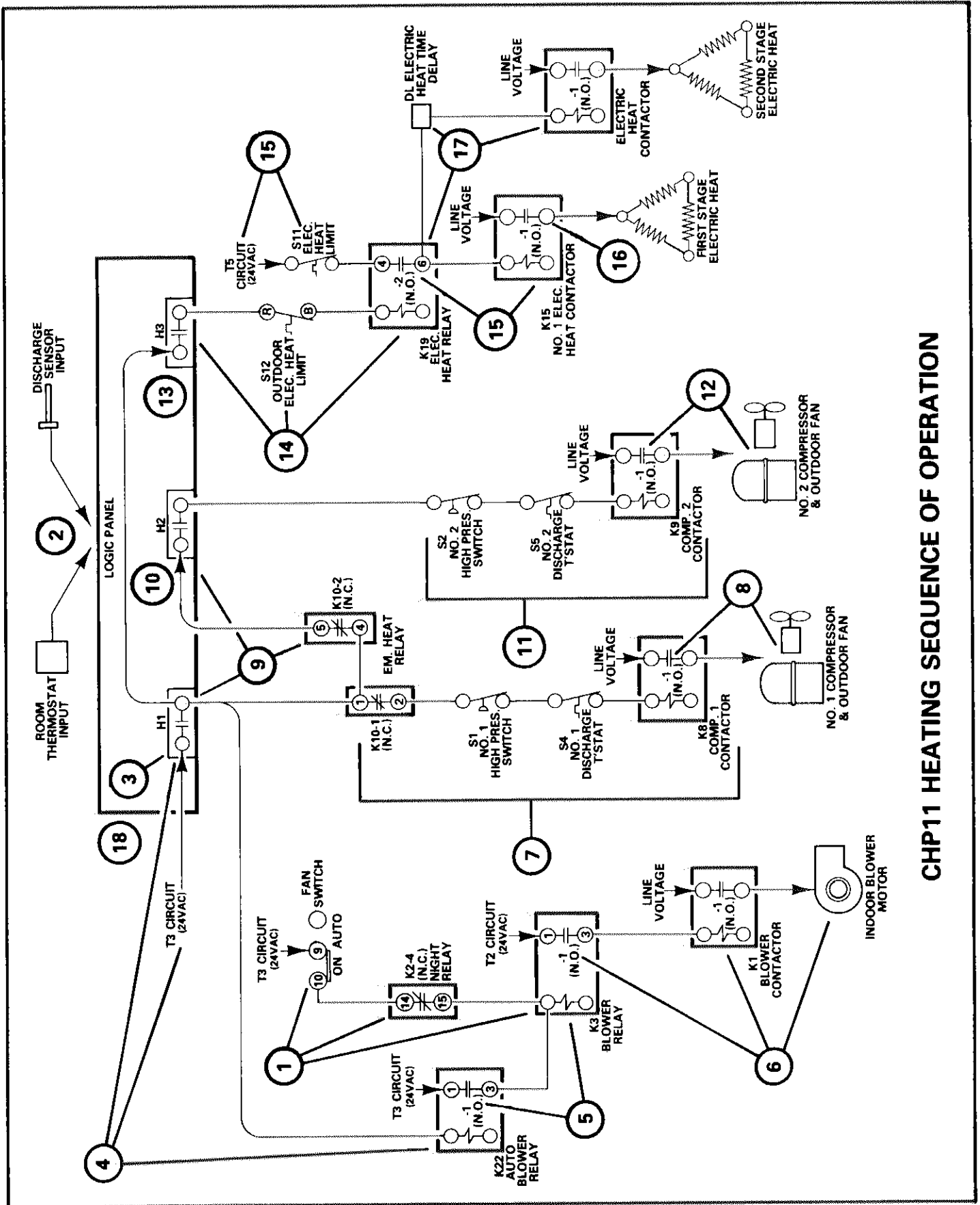

CHP11 HEATING SEQUENCE OF OPERATION

FIGURE 36

C - Defrost Cycle (Figure 37)

- 1 - The No. 1 Compressor Contactor (K8) is powered per Figure 36.
- 2 - A parallel circuit goes to the Defrost Clock Timer contacts (CMC1). These contacts make every 90 minutes for approximately 20 seconds.
- 3 - When the outdoor coil pressure drops to 45 psig the Defrost Pressure Switch (S7) makes.
- 4 - If CMC1 contacts and S7 make together, the Defrost Relay (K4) is energized.
- 5 - The N.O. K4-3 contacts close to latch in the circuit. This assures that the defrost cycle will continue until S7 opens.
- 6 - The N.O. K4-1 contacts make to energize the No. 1 Reversing Valve (L1) through the N.C. K12-1 contacts and T2 transformer. L1 switches the refrigerant flow from bottom

to top of outdoor coil during a defrost cycle. This provides more positive defrost and better condensate run-off.

- 7 - On 200V & 230V units, the N.C. K4-2 contact opens to de-energize the outdoor fan motor.
- 8 - On 460V & 575V units, the N.C. K4-2 contact opens to de-energize the No. 1 Condenser Fan Contactor (K5). N.O. K5-1 contact then opens to de-energize outdoor fan motor.
- 9 - When outdoor coil pressure rises to 225 psig, S7 opens to de-energize K4 and return unit into normal operation.

Note - The defrost cycle functions the same for the No. 2 refrigerant circuit.

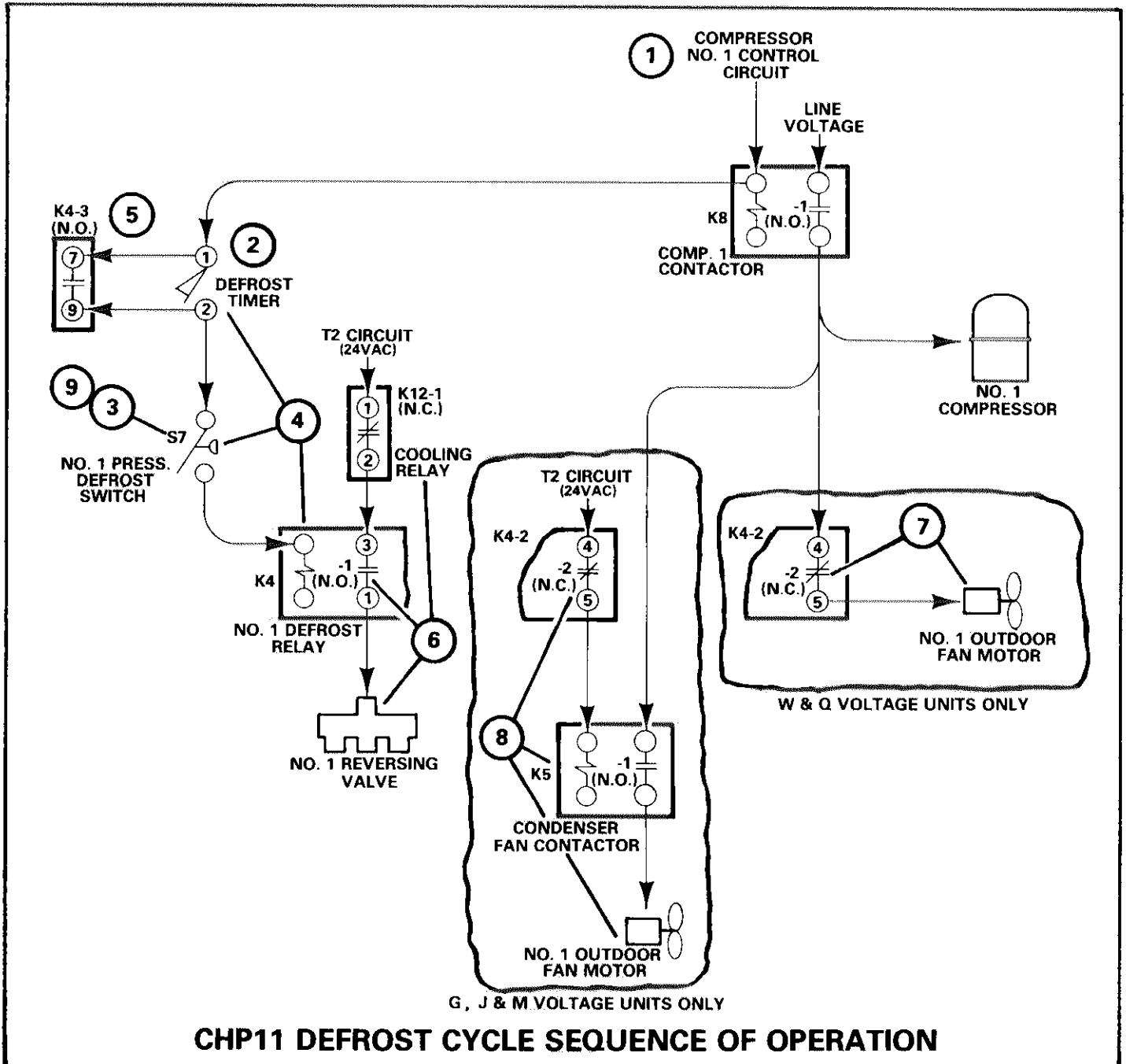

FIGURE 37

D - Emergency Heat (Figure 38)

This function is only available with use of a switching sub-base or switching status panel.

- 1 - By placing the system switch to emergency heat, the red LED indicator light comes on.
- 2 - At the same time the 20VDC circuit energizes K10 Emergency Heat Relay.
- 3 - N.C. K10-1 and N.C. K10-2 open to lock out the compressor control circuits. Auxilliary heat must satisfy any heating demand. The hot water valve motor still responds directly to the heating ramp signal.

Electric Heat Only

- 4 - N.O. K10-3 closes to by-pass the Outdoor Electric Heat Limit (S12).

- 5 - When the heating demand closes "H3" at the logic panel, K19 Electric Heat Relay is energized regardless of ambient temperature.
- 6 - N.O. K19-2 contacts close to power K15 No. 1 Electric Heat Contactor through T5 transformer and the Electric Heat Limit (S11). S11 opens at discharge temperatures above setpoint.
- 7 - N.O. K15-1 contacts close to energize the first stage of elements.
- 8 - K19-2 also powers the additional stages of electric heat through time delays.
- 9 - To return unit to normal heating operation, move the system switch to "heat".

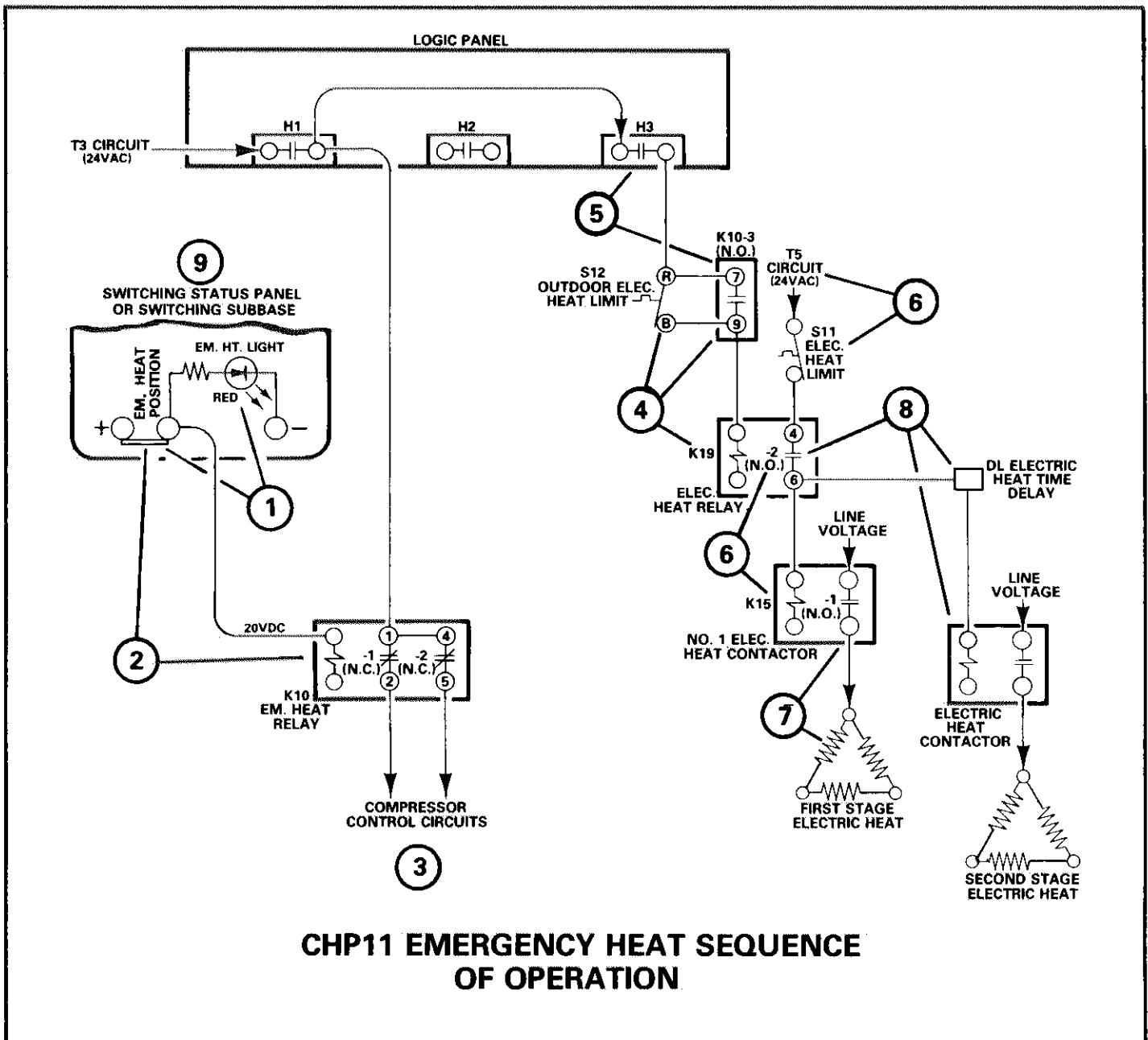

FIGURE 38

XIII - TROUBLE SHOOTING

The CHP11 is engineered for troubleshooting convenience. Many problems can be isolated at the unit make-up box before opening unit access panels. All that is needed is an ohmmeter and an AC/DC voltmeter. Perform the checks outlined in the following flow charts.

Each check shows the terminal block, meter test points and voltage.

Additional information is available for troubleshooting the Honeywell solid-state control system. Refer to the "Miscellaneous" section within this manual. Before condemning any components, be sure all terminal connections are tight in the circuit. This is particularly important on DC voltages, especially at the thermostat.

CHP11 NO HEATING OR INSUFFICIENT HEATING

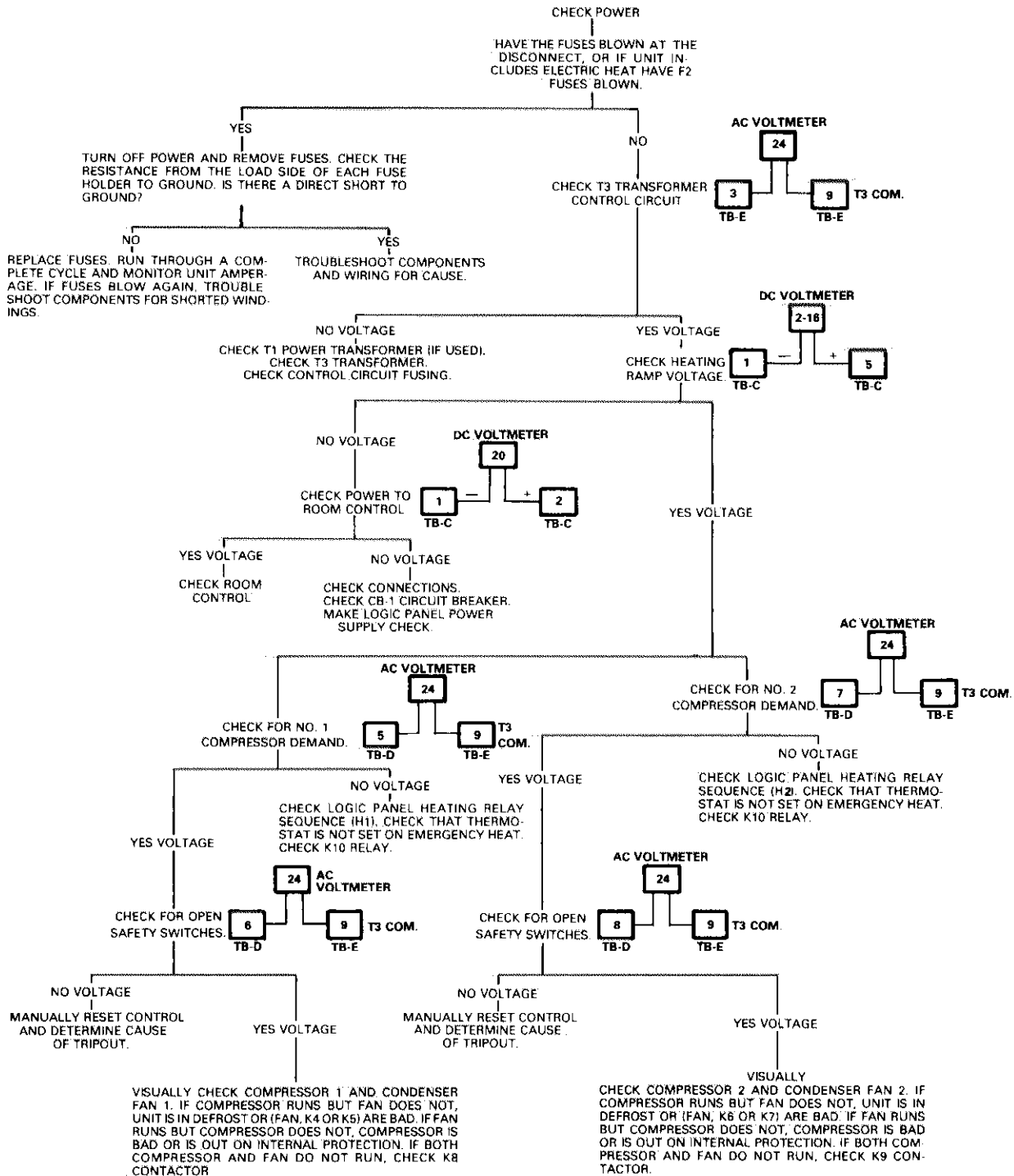

CHP11 NO COOLING OR INSUFFICIENT COOLING

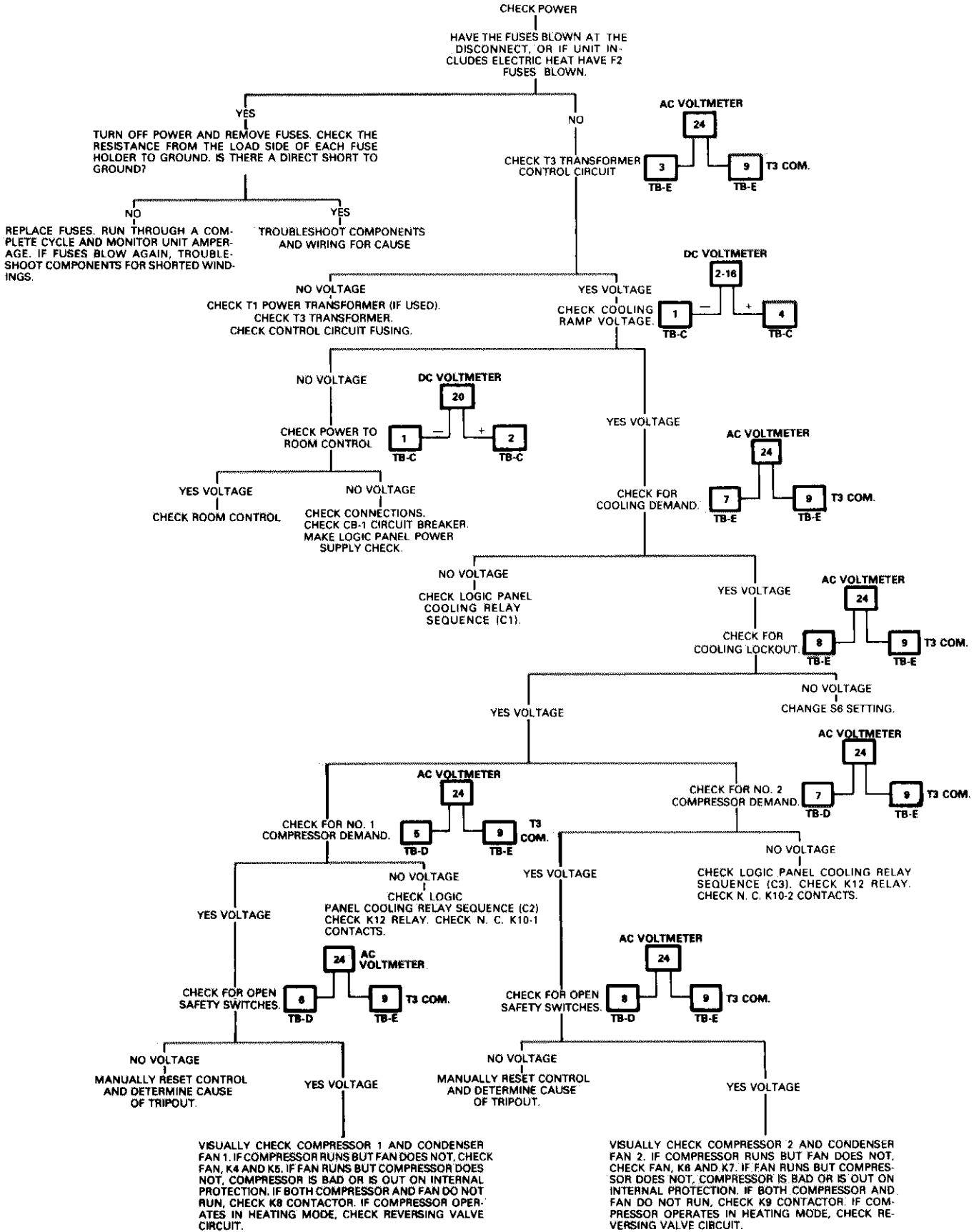

ELECTRIC HEAT TROUBLESHOOTING CHART

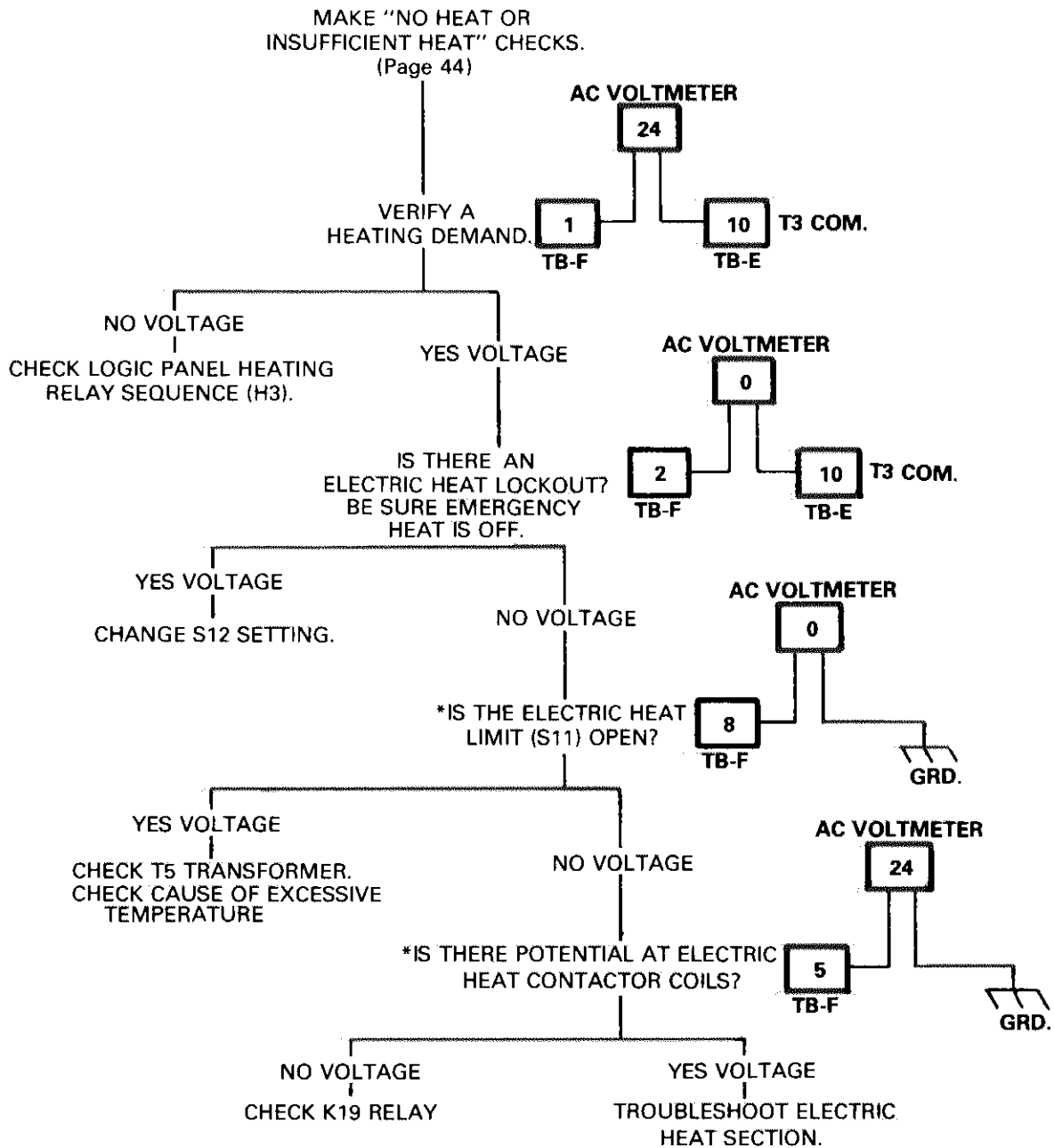

*THESE CHECKS CANNOT BE MADE ON ECH11 "W, Q" VOLTAGE UNITS WITH 15 KW OR ECH11 "G, J, M" VOLTAGE UNITS WITH 15/30 KW.