



# CHP11-953-1353-1853 AND 2753 — 50 Hz SINGLE PACKAGE HEAT PUMPS

\*24.0 to 64.5 kW (82 000 to 220 000 Btuh) Cooling Capacity  
\*23.0 to 61.5 kW (78 500 to 210 000 Btuh) Heating Capacity  
9.4 to 56.1 kW (32 100 to 191 400 Btuh) Optional Electric Heat  
56.6 to 130.0 kW (193 000 to 445 000 Btuh) Optional Hot Water Heat

\*At ARI Standard Test Conditions

## High Efficiency Rooftop Units Feature Energy Saving Operation, Low Operating Cost and Application Flexibility

Lennox single package CHP11 heat pump units are designed for rooftop installation with bottom or end handling of supply and return air. A separate roof mounting frame (optional) mates to the bottom of the unit and when flashed into the roof permits weatherproof duct connection and entry into the structure. No additional roof curbing or flashing is required. The roof mounting frame is shipped knocked down and must be field assembled. Units are available with supplemental electric or hot water heat.

Energy and operational cost saving features include: Demand oriented solid-state electronic control system. Dual refrigerant circuits to control system capacity and reduce energy usage. POWER SAVER® option will provide "free cooling" by using outdoor air in lieu of mechanical refrigeration. POWER SAVER enthalpy control provides maximum use of the outdoor air for "free" cooling.

The insulated single cabinet houses highly efficient air cooled direct expansion cooling, powerful belt drive blower, air filters and optional POWER SAVER dampers or minimum fresh air dampers and exhaust dampers. The energy conserving POWER SAVER dampers are available factory or field installed. The exhaust dampers and minimum fresh air dampers (manual or automatic) require field installation.

The complete factory sealed direct expansion cooling consists of two independent refrigeration systems including separate compressors and their independent outdoor coil and fan with a separate circuit in the single indoor coil. Lennox augments its reliable operating components with a full complement of standard comfort and safety controls for both the cooling system and the heating options. Dual set point room thermostat is furnished as standard. Separate supply and return air double duct, combination ceiling supply and return air duct, or horizontal (end) duct systems are applicable to the units. A choice of stepdown of flush model diffusers are available for ceiling supply and return air distribution systems.

CHP11-953 and CHP11-1353 units have been tested in the Lennox Laboratory environmental test room at Air-Conditioning and Refrigeration Institute (ARI) Standard 240 test conditions. Additionally, units have been tested and rated in the Lennox sound test room according to Air-Conditioning and Refrigeration Institute (ARI) Standard 270. CHP11-1853 and CHP11-2753 models have been tested and rated at Air-Conditioning and Refrigeration Institute (ARI) Standard 340 test conditions. Blower data is from unit tests in the Lennox air test chamber. Units and components within are bonded for grounding to meet safety standards for servicing required by Underwriter's Laboratory (U.L.) and the International Electrotechnical Commission (IEC). Units are shipped completely factory assembled, piped, and wired. In addition, each unit is test operated at the factory insuring proper operation and unit dependability in the field.

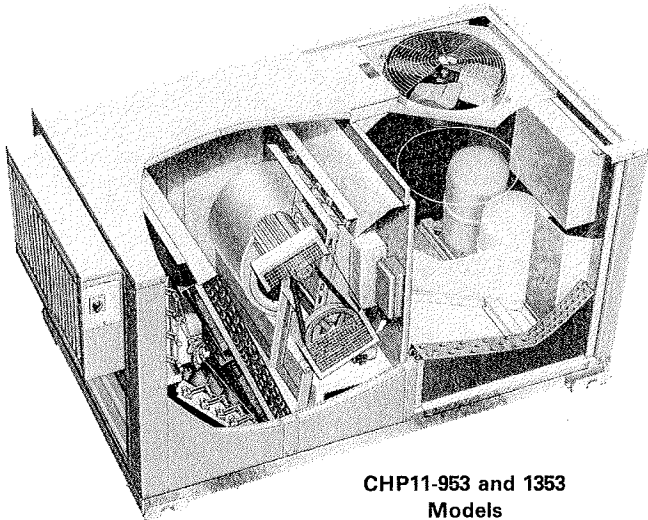

CHP11-953 and 1353 Models

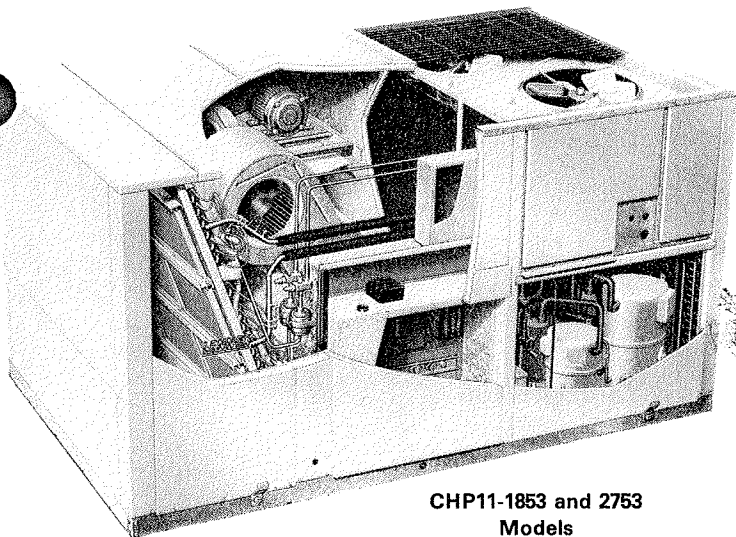

CHP11-1853 and 2753 Models

### Typical Applications

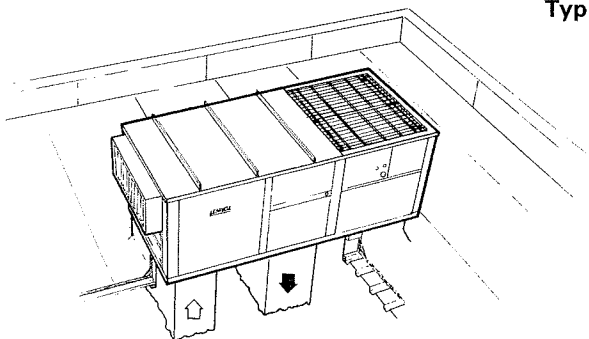

Rooftop Installation with Double Duct Air Distribution System

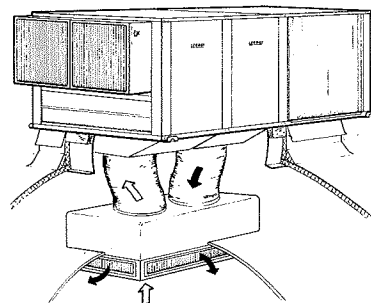

Rooftop Installation with Combination Ceiling Supply and Return Air System

NOTE — Specifications, Ratings and Dimensions subject to change without notice.

## FEATURES

**Lennox Solid-State Control System** — Energy saving electronic control system measures the deviation between room temperature and set point and then controls the supply air temperature to meet the load requirements. The control system consists of a dual set point room thermostat located in the conditioned space or a dual set point transmitter with a remote temperature sensor in the conditioned space, a discharge temperature sensor located in the supply air duct of the unit, Logic Panel installed in the unit and a modulating damper actuator for the POWER SAVER dampers. This solid-state control system will operate the unit to automatically match its output to the load with minimum space temperature variation. To accomplish this the room thermostat or transmitter, in the conditioned space, is continuously comparing space temperature with the setpoint and sending a varying load signal to the logic panel. The heat-cool relays in the logic panel respond to the signal and cycle the stages of heating or cooling and POWER SAVER position to match the output to the load condition. To maintain stable space temperatures the Logic Panel balances the space thermostat demand signal against the system output. System output is measured by the discharge temperature sensor in the supply air duct. The combined demand and output signals determine POWER SAVER position and number of heating or cooling stages energized. The discharge sensor also provides a positive modulating low limit signal to the Logic Panel ensuring that the POWER SAVER will modulate closed if the discharge air gets too cold. Additionally, on power failure, system recycles all stages to off. When power is restored, system sequences stages back on with a time delay between stages.

**Durable Cabinet** — Rugged leaktight cabinet is constructed of heavy gauge galvanized steel. Cabinet is subject to a five station zinc phosphate metal wash process resulting in a perfect bonding surface for a paint finish of baked-on outdoor enamel. Long lasting enamel finish provides maximum protection from the weather. Large removable panels allow complete service access. Electrical inlets are provided in the cabinet for wiring entry. Wiring junction box and control boxes with all controls factory installed are conveniently located for service access. Lifting brackets are furnished on each corner of the base for ease of handling and rigging. Drainage holes in base rails provide moisture removal.

**Cabinet Insulation** — Base section and cabinet panels exposed to conditioned air are lined with thick fiberglass insulation. This results in quiet and efficient operation due to the excellent acoustical and insulating qualities of fiberglass. The cabinet panels have 76mm (3 inch) thick 8 kg/m<sup>3</sup> (1/2 lb./ft.<sup>3</sup>) density fiberglass insulation and the base 13mm (1/2 inch) thick 96 kg/m<sup>3</sup> (6 lb./ft.<sup>3</sup>) density. Insulation is sandwiched between the cabinet panel and a galvanized steel panel inner liner protecting the insulation indefinitely. It will never erode or tear away from a panel to clog or impair unit operation.

**Refrigeration System** — Factory sealed refrigerant system consists of compressors, outdoor coils and direct drive fans, indoor (dual circuits) coil and blower, check and expansion valves, high capacity driers, high pressure switches (manual reset), discharge temperature thermostat, reversing valves, suction line accumulators, refrigerant lines connected and a full operating charge of refrigerant. Dual independent refrigerant circuits provide staging control to fit varying cooling loads.

**Lennox Indoor and Outdoor Coils** — Extra large surface area and circulating of Lennox designed coils provide maximum cooling efficiency, excellent heat transfer and low air resistance. Lennox fabricated coils are constructed of precisely spaced ripple-edged aluminum fins fitted to durable copper tubes. Fins are equipped with collars that grip tubing for maximum contact area. Flared shoulder tubing connections and silver soldering provide tight, leakproof joints. Long life copper tubing is easy to field service. Coil is thoroughly factory tested under high pressure to insure leakproof construction. The indoor coil is face split with two separate circuits. Each circuit has its check and expansion valve, reversing valve, accumulator, outdoor coil, fan, compressor and refrigerant charge.

**Drain Pan** — Deep, corrosion resistant evaporator coil drain pan is constructed of heavy gauge galvanized steel. Drain pipes extend outside of cabinet on both sides for convenient and easy connections.

**Defrost Control** — A clock timer defrost control gives a defrost cycle every 1 hour and 48 minutes of compressor 'on' time at temperatures below 7°C (45°F). A pressure switch mounted on the outdoor coil determines when the defrost cycle is required and also when to terminate a cycle. During the defrost cycle, the supplemental electric or hot water heat will operate as dictated by the logic panel in response to the combined thermostat and discharge sensor signal.

**Dependable Lennox Compressors** — Lennox compressors give staging control to fit varying cooling load requirements. CHP11-953 and CHP11-1353 models are equipped with two Lennox series "A" single speed compressors. CHP11-1853 model consists of a series "A" and series "D" single speed compressor. The CHP11-2753 has two single speed series "D" compressors. Reliable Lennox compressor is hermetically sealed with built-in protection from excessive current and temperatures. Suction cooled and overload protected. Large housing, spring loaded discharge valve, high intake ports and crankcase heater result in effective slugging protection. In addition, the large volume housing provides abundant oil reserve. Oil pump is designed to assure complete lubrication. Special blended oil (natural and synthetic) withstands high temperatures without breakdown. Vertical crankshaft is statically and dynamically computer balanced. Low clearance volume piston and cylinder yields increased volumetric efficiency. Strategically located high efficiency discharge muffler reduces pulsation in discharge line and allows quiet operation. Immersible self-regulating type crankcase heater is temperature actuated to operate only when required and ensures proper lubrication at all times. Motor is located within refrigerant flow pattern resulting in low motor winding temperatures. Solid-state temperature sensors imbedded in motor windings provides protection from excessive temperatures. Conveniently located control box allows one spot servicing. Entire running gear assembly is spring mounted within the sealed housing. In addition, the compressor is installed in the unit on resilient rubber mounts.

**Efficient Outdoor Coil Fans** — Two direct drive fans draw large air volumes uniformly through dual outdoor coils and discharge it vertically, up and away from the building. Fan orifice design and low fan tip speed keeps operating sound level at a minimum. Uniform air flow through the coils result in high capacity. Ball bearing fan motor is permanently lubricated and overload protected. A rain shield on the motor provides additional protection from moisture. Corrosion resistant coated steel wire fan guards are furnished.

**Powerful Supply Air Blower** — Belt drive centrifugal blower delivers large air volume efficiently and with minimum power consumption. Blower assembly is mounted to rugged angle iron frame with the entire blower and frame assembly vibration isolated on rubber mounts. Ball bearings are permanently sealed and lubricated. Blower wheel is statically and dynamically balanced. Design of motor mounting base permits quick and simple motor changeover, belt tension adjustment or belt changing. A choice of motor outputs and drives is available. Adjustable motor pulley allows for variable speed adjustments. Motor is overload protected. Drives are covered with a protective guard on CHP11-953-1353 models.

**Air Filters** — 25mm (1 inch) thick frame type throwaway filters are furnished as standard. Fiberglass media is oil impregnated for increased efficiency. Filters are easily accessible for quick and simple replacement. Filter rack will accept 51mm (2 inch) thick filters.

**Optional Electric Heat** — Available factory or field installed. Helix wound nichrome heating elements are exposed directly in the air stream resulting in instant heat transfer, lower coil temperatures and long service life. Elements are accurately located and insulated from the heavy gauge steel support frame by high quality insulators. Time delays bring the elements on and off the line in sequence in response to demand with a time delay between elements. Elements are equipped with discharge air limit control and back-up replaceable limits providing positive protection in case of overheating.

**Optional Hot Water Heat** — A factory installed hot water coil is equipped with a three-way modulating valve. Factory installed freeze stat activates valve to circulate water during freezing conditions. A glycol solution may also be used in the system to provide freeze protection. Lennox designed and built coil has large face area, excellent heat transfer and low air resistance. Constructed of precisely spaced ripple-edged aluminum fins fitted to durable copper tubes. Durable copper tubing assures long service life and easy servicing. Each joint is silver soldered and coil is factory tested under pressure to insure leakproof construction.

## FEATURES

**Thermostat (Furnished)** — Dual set point room Thermostat (25C52) has separate heating-cooling locking set points concealed under the cover and does not have indicating thermometer. The room thermostat has integral sensor and installs in the conditioned space. For remote temperature control an optional transmitter (25C51) installs outside the conditioned space with a Remote Sensor (58C92) in the conditioned area or a Return Air Sensor (27C40) in the return air duct of the unit. Transmitter and sensor must be ordered extra. If desired in multiple unit applications, that serve a common space, up to six units can be controlled from a single thermostat. Thermostat and transmitter are furnished with a wiring wallplate and may be installed horizontally or vertically. In addition, an optional Switching Subbase (58C94) is available and must be ordered extra. It is equipped with system selector switch (HEAT — AUTO — COOL — EMERGENCY HEAT) and fan switch (AUTO — ON — SYSTEM OFF). Fan switch provides a choice of intermittent (AUTO) or continuous (ON) blower operation.

**Optional SP11 Remote Status Panel** — The operation of the unit can be checked at a glance on the Remote Status Panel (12F83) conveniently located within the conditioned area. Signal lights on the panel indicate "Cool Mode", "Heat Mode", "Compressor 1", "Compressor 2", "No Heat" and "Filter". The cool mode signal light is green when lit and indicates Power Saver or cooling operation. Heat Mode light is green and reflects heating operation. Compressor 1 and Compressor 2 lights are green when operating and will turn red if there is an operational malfunction. The No Heat and Filter lights will show red and indicate a requirement for service. Additional controls are required for use with the Status Panel and must be specified when ordering. Filter Switch Kit (97C85) is used in conjunction with the Filter light. CHP11-953-1353 units with electric heat require a Current Sensing Relay (59C94) and with hot water heat a Proving Relay (51C22) for operation of No Heat light. CHP11-1853-2753 models with electric heat or hot water heat require a Proving Relay (14F57) for operation of the No Heat light.

**Optional SSP11 Remote Switching Status Panel** — The operation of the unit can be controlled and observed on the Switching Status Panel (12F84) conveniently located within the conditioned area. Signal lights on the panel indicate "Cool Mode", "Heat Mode", "Compressor 1", "Compressor 2", "No Heat" and "Filter". The Cool Mode signal light is green when lit and indicates Power Saver or cooling operation. Heat Mode light is green and reflects heating operation and will light red when switched to emergency heat mode. Compressor 1 and Compressor 2 lights are green when operating and will turn red if there is an operational malfunction. The No Heat and Filter lights will show red and indicate a requirement for service. Additionally panel is equipped with a system selector switch (OFF — HEAT — AUTO — COOL — EMERGENCY HEAT), fan switch (AUTO — ON) and after hours timer. Fan switch provides a choice of intermittent (AUTO) or continuous (ON) blower operation. Manually operated after hours timer (0 to 12 hours) overrides night setback controls providing normal operation for time period set. A momentary push button switch is used to initiate the time period. Additional controls are required for use with the Status Panel and must be specified when ordering. Filter Switch Kit (97C85) is used in conjunction with the Filter light. CHP11-953-1353 units with electric heat require a Current Sensing Relay (59C94) and with hot water heat a Proving Relay (51C22) for operation of No Heat light. CHP11-1853-2753 models with electric heat or hot water heat require a Proving Relay (14F57) for operation of the No Heat light.

**Optional RMF11 Roof Mounting Frame** — Sturdy mounting frame mates to the single package unit and provides an automatic weather sealed rooftop installation. Shipped knocked down for ease of shipping and handling it is easily field assembled. A nailer strip is secured to the frame sides to facilitate flashing. Approved by the U.S. National Roofing Contractors Association.

**Optional RMFH11 Roof Mounting Frame** — Frame mates to CHP11 unit and provides horizontal end supply and return air (over/under) duct connection. Supply air connection is in end of frame. Return air connection is made at indoor section end of unit. Shipped knocked down for ease of shipping and handling; it is easily field assembled. See dimension drawing and installation detail sketch.

**Optional RMFA11 Roof Mounting Frame (CHP11-953-1353 only)** — Retrofit adapter frame is available for CHP11-953-1353 model replacement of existing CHP8-953-1353 unit installations. The RMFA11 frame adapts to the existing RMF3 frame and provides a weather sealed connection with minimum installation cost. RMFA11 frame is shipped knocked down for ease of shipping and handling, it is easily field assembled. A nailer strip is secured to the frame sides to facilitate flashing. See dimensions drawing and installation detail sketch.

**Optional PSD11 Power Saver** — Available factory or field installed. Lennox Power Saver system consists of: mechanically linked outdoor air and recirculated air dampers. Damper blades are gasketed for tight seal and quiet operation. Formed damper blades rotate smoothly in nylon bearings. The positioning of these dampers is accomplished by a 24 volt modulating spring return damper actuator and controlled by the room thermostat or transmitter, discharge sensor and enthalpy control. The enthalpy control allows (0 to 100%) outdoor air to be used for "free" cooling when outdoor air humidity and temperature is acceptable. An outdoor air intake with rain eliminator vanes is furnished and field installs over the outdoor air dampers external to the unit. For field installation the two damper sections slide in cavities provided in the unit cabinet. Power Saver is shipped factory wired and only requires plug-in field connections.

**Optional OADM11 Minimum Fresh Air Damper Section (CHP11-953-1353 only)** — Field installs external to the unit cabinet. Available for manual or automatic operation. Manually operated damper may be adjusted and locked in place to provide outdoor air quantities of up to 25%. Automatic damper operation is available with the addition of a spring return 3 position damper actuator. Order Automatic Fresh Air Damper Kit 27F89.

**Optional OAD11 Minimum Fresh Air Dampers (CHP11-1853-2753 only)** — Damper section complete with cleanable polyurethane air filter field installs external to the unit cabinet. Available for manual or automatic operation. Damper assembly allows a fixed amount of outdoor air into the system and can be adjusted for air quantities up to 25%. Automatic damper operation is available with the addition of a spring return 3 position damper actuator. Actuator only requires plug-in connection for operation. Order Automatic Fresh Air Damper Kit 99C94.

**Optional GED11 Gravity Exhaust Air Dampers** — Dampers field install in space provided in the unit. Pressure operated extruded aluminum dampers operate smoothly in nylon bearings. Damper blades are equipped with seal gaskets for tight seal and quiet operation.

**Optional PED11 Power Exhaust Dampers (CHP11-1853-2753 only)** — Field installs in space provided in the unit cabinet. Fans provide system pressure relief and are interlocked to run when return air dampers are closed and supply air blowers are operating. Motors are overload protected. Pressure operated extruded aluminum dampers ride in nylon bearings and are equipped with seal gaskets resulting in tight seal and quiet operation. Dampers prevent blow-back and outdoor air infiltration during off cycle.

**Optional Night Setback Controls** — Field installed 7 Day Time Clock with Reserve (91C73) automatically programs the unit for night setback operation. System room thermostat or transmitter controls both day and night operation.

**Optional Disconnect Mounting Kit (CHP11-953-1353 only)** — Disconnect kit (LB-38208BA) provides a convenient mounting location for field furnished remote disconnect switch. Kit field installs to outside of unit cabinet adjacent to electrical inlets.

## SPECIFICATIONS

Model Number		CHP11-953	CHP11-1353
★ ARI Standard 270 Sound Rating Number (Bels)		8.2	8.4
*Cooling Capacity at ARI Standard 240 Test Conditions	Cooling Capacity — kW (Btuh)	24.0 (82 000)	32.2 (110 000)
	Total power input — kW	9.75	13.1
	Coefficient of Performance (Output/Input)	2.45	2.45
	Energy Efficiency Ratio (Btuh/watts)	8.4	8.4
	Dehumidifying capacity	20%	20%
*High Temperature Heating Capacity	Total Capacity — kW (Btuh)	23.0 (78 500)	32.0 (109 200)
	Total power input — kW	8.0	10.7
	Coefficient of Performance (Output/Input)	2.9	3.0
*Low Temperature Heating Capacity	Total capacity — kW (Btuh)	12.3 (41 900)	16.4 (56 000)
	Total power input — kW	6.45	8.2
	Coefficient of Performance (Output/Input)	1.9	2.0
Refrigerant charge (R-22)		9.6 kg (21 lbs. 6 oz.)	13.6 (30 lbs. 0 oz.)
Indoor Coil	Net face area — m <sup>2</sup> (sq. ft.)	0.77 (8.3)	1.1 (12.0)
	Tube outside diameter — mm (in.) — Rows	12.7 (1/2) — 4	12.7 (1/2) — 4
	Fins per m (fins per inch)	591 (15)	591 (15)
Indoor Coil Blower	Wheel nominal diameter x width — mm (in.)	(1) 381 x 229 (15 x 9)	(1) 381 x 381 (15 x 15)
	Motor output — kW (hp) (Minimum — Maximum)	1.1 — 2.2 (1-1/2 — 3)	2.2 — 3.7 (3 — 5)
Outdoor Coil	Net face area — m <sup>2</sup> (sq. ft.)	1.4 (14.8)	1.8 (19.9)
	Tube outside diameter — mm (in.) — Rows	12.7 (1/2) — 3	12.7 (1/2) — 3
	Fins per m (fins per inch)	591 (15)	591 (15)
Outdoor Coil Fans	Diameter — mm (in) — Blades	(2) 508 (20) — 4	(2) 610 (24) — 4
	Air Volume — m <sup>3</sup> /s (cfm)	2.4 (5000)	3.35 (7100)
	Motor output — watts (hp)	(2) 249 (1/3)	(2) 373 (1/2)
	Total motor input — watts	710	1000
Condensate drain connections — female pipe thread — mm (in.)		(2) 19 (3/4)	(2) 19 (3/4)
Number and size of filters — mm (in.)		(4) 406 x 508 x 25 (16 x 20 x 1)	(6) 406 x 508 x 25 (16 x 20 x 1)
Net weight of basic unit — kg (lbs.) (1 Package)		547 (1205)	719 (1585)
Optional Hot Water Coil	Model Number	HWC11-95 (29 kg) (65 lbs.)	HWC11-135 (34 kg) (75 lbs.)
	**Heating capacity — kW (Btuh)	56.6 (193 000)	61.8 (211 000)
	Net face area — m <sup>2</sup> (sq. ft)	0.42 (4.5)	0.60 (6.5)
	Tube outside diameter — mm (in.) — Rows	12.7 (1/2) — 2	12.7 (1/2) — 2
	Fins per m (fins per inch)	630 (16)	394 (10)
Connections — outside diameter — mm (in.)		34.9 (1-3/8) sweat	34.9 (1-3/8) sweat
Optional Electric Heat Model Number		ECH11-95	ECH11-135
Optional Roof Mounting Frame — (Net weight)	Standard Frame	RMF11-95 (68 kg) (150 lbs.)	RMF11-135 (82 kg) (180 lbs.)
	Horizontal Frame	RMFH11-95 (93 kg) (205 lbs.)	RMFH11-135 (111 kg) (245 lbs.)
	Adapter Frame	RMFA11-95 (116 kg) (255 lbs.)	RMFA11-135 (132 kg) (290 lbs.)
Optional Power Saver and Controls — (Net weight)		PSD11-95 (44 kg) (97 lbs.)	PSD11-135 (74 kg) (163 lbs.)
Optional Gravity Exhaust Dampers — (Net weight)		GED11-95 (6 kg) (13 lbs.)	GED11-135 (8 kg) (18 lbs.)
Optional Ceiling Supply and Return Step-Down Diffuser — (Net weight)		RTD11-95 (38 kg) (84 lbs.)	RTD11-135 (43 kg) (95 lbs.)
Optional Ceiling Supply and Return Flush Diffuser — (Net weight)		FD11-95 (38 kg) (84 lbs.)	FD11-135 (43 kg) (95 lbs.)
Optional Ceiling Supply and Return Transitions — (Net weight)		SRT11-95 (13 kg) (28 lbs.)	SRT11-135 (15 kg) (32 lbs.)
Optional Minimum Fresh Air Dampers (Manual) — (Net weight)		OADM11-95 (26 kg) (57 lbs.)	OADM11-135 (52 kg) (114 lbs.)
Optional Automatic Fresh Air Damper Kit — (Net weight)		27F89 (7 kg) (15 lbs.)	27F89 (7 kg) (15 lbs.)
Optional Remote Status Panel		SP11 (12F83)	SP11 (12F83)
Optional Remote Switching Status Panel		SSP11 (12F84)	SSP11 (12F84)
Optional Disconnect Mounting Kit		LB-38208BA (5 kg) (10 lbs.)	LB-38208BA (5 kg) (10 lbs.)

★ Sound Rating Number in accordance with Air-Conditioning and Refrigeration Institute (ARI) Standard 270.

\*Rated at Air-Conditioning and Refrigeration Institute (ARI) Standard 240 conditions; 60 L/s indoor air volume per kW of cooling capacity (450 cfm per ton).

**Cooling Ratings** — 35°C (95°F) outdoor air temperature, 27°C(80°F) dry bulb and 19.4°C (67°F) wet bulb entering indoor coil air.

**High Temperature Heating Ratings** — 8°C (47°F) dry bulb and 6.1°C (43°F) wet bulb outdoor air temperature and 21°C (70°F) entering indoor coil air.

**Low Temperature Heating Ratings** — minus 8°C (17°F) dry bulb and minus 9.4°C (15°F) wet bulb outdoor air temperature and 21°C (70°F) entering indoor coil air.

\*\*Rated at 82°C (180°F) supply water temperature, 21°C (70°F) entering air temperature, 11°C (20°F) water temperature drop and 60 L/s air volume per kW of cooling capacity (450 cfm per ton). See hot water capacity curves for heating capacities at other conditions.

## SPECIFICATIONS

Model Number			CHP11-1853	CHP11-2753	
*At ARI Standard 340 Test Conditions	Cooling Capacity	Cooling Capacity — kW (Btuh)	48.0 (164 000)	64.5 (220 000)	
		Total power input — kW	19.5	25.9	
		Coefficient of Performance (Output/Input)	2.45	2.5	
		Energy Efficiency Ratio (Btuh/Watts)	8.4	8.5	
		Dehumidifying capacity	22%	20%	
	High Temperature Heating Capacity	Total capacity — kW (Btuh)	47.4 (161 800)	61.5 (210 000)	
		Total power input — kW	16.3	21.2	
		Coefficient of Performance (Output/Input)	2.9	2.9	
	Low Temperature Heating Capacity	Total capacity — kW (Btuh)	28.1 (96 000)	38.1 (130 000)	
		Total power input — kW	13.4	18.1	
Coefficient of Performance (Output/Input)		2.1	2.1		
Refrigerant (22) charge			21.9 kg (48 lbs. — 8 oz.)	29.5 kg (65 lbs. — 0 oz.)	
Indoor Coil Blower	Blower Wheel nominal diameter x width — mm (in.)		(1) 381 x 229 (15 x 9)	(1) 381 x 381 (15 x 15)	
	Motor output — kW (hp) (minimum-maximum)		3.7 (5)	3.7 — 5.6 (5 — 7-1/2)	
Indoor Coil	Net face area — m <sup>2</sup> (sq. ft.)		1.60 (17.2)	2.18 (23.5)	
	Tube outside diameter — mm (in.) — Rows		12.7 (1/2) — 4	127 (1/2) — 4	
	Fins per m (fins per inch)		512 (13)	591 (15)	
Outdoor Coil	Net face area — m <sup>2</sup> (sq. ft.)		2.96 (31.9)	3.61 (38.9)	
	Tube outside diameter — mm (in.) — Rows		(1) 12.7(1/2) — 3 and (1) 12.7(1/2) — 4	12.7 (1/2) — 4	
	Fins per m (fins per inch)		591 (15)	591 (15)	
Outdoor Coil Fans	Diameter — mm (in.) — Blades		(1) 610(24) — 4 and (1) 660(26) — 5	(2) 660 (26) — 5	
	Air volume — m <sup>3</sup> /s (cfm)		4.37 (9250)	5.27 (11 200)	
	Motor output — watts (hp)		(1) 373 (1/2) and (1) 560 (3/4)	(2) 560 (3/4)	
	Total motor input — watts		1100	1225	
Condensate drain connections — female pipe thread — mm (in.)			(2) 32 (1-1/4)	(2) 32 (1-1/4)	
Number and size of filters — mm (in.)			(9) 406 x 508 x 25 (16 x 20 x 1)	(11) 406 x 508 x 25 (16 x 20 x 1)	
Net weight of basic unit — kg (lbs.) (1 Package)			1043 (2300)	1315 (2900)	
Optional Electric Heat Model Number			ECH11-185	ECH11-275	
Optional Hot Water Coil	Model Number and net weight		HWC11-185 (54 kg) (120 lbs.)	HWC11-275 (59 kg) (130 lbs.)	
	**Heating capacity — kW (Btuh)		104.0 (335 000)	130 (445 000)	
	Net face area — m <sup>2</sup> (sq. ft.)		0.92 (9.9)	1.04 (11.2)	
	Tube outside diameter — mm (in.) — Rows		12.7 (1/2) — 2	12.7 (1/2) — 2	
	Fins per m (fins per inch)		630 (16)	630 (16)	
	Connections — outside diameter — mm (in.)		41.3 (1-5/8) sweat	41.3 (1-5/8) sweat	
Optional Roof Mounting Frames — (Net weight)			Standard Frame	RMF11-185 (120 kg) (265 lbs.)	RMF11-275 (143 kg) (315 lbs.)
			Horizontal Frame	RMFH11-185 (170 kg) (375 lbs.)	RMFH11-275 (200 kg) (440 lbs.)
Optional Power Saver & Controls — (Net weight)			PSD11-185 (107 kg) (235 lbs.)	PSD11-275 (132 kg) (290 lbs.)	
Optional Gravity Exhaust Dampers — (Net weight)			GED11-185 (11 kg) (25 lbs.)	GED11-275 (14 kg) (30 lbs.)	
Optional Power Exhaust Dampers	Model Number — (Net weight)		PED11-185 (50 kg) (110 lbs.)	PED11-275 (68 kg) (150 lbs.)	
	Exhaust Fans	Diameter — mm (in.) — Blades	(2) 457 (18) — 5	(3) 457 (18) — 5	
		Total air volume — m <sup>3</sup> /s (cfm)	2.0 (4200)	2.8 (5900)	
		Motor output — watts (hp)	(2) 187 (1/4)	(3) 187 (1/4)	
		Total motor input — watts	610	915	
Optional Ceiling and Return Step-Down Diffuser — (Net weight)			RTD11-185 (54 kg.) (120 lbs.)	RTD11-275 (77 kg) (170 lbs.)	
Optional Ceiling Supply and Return Flush Diffuser — (Net weight)			FD11-185 (54 kg) (120 lbs.)	FD11-275 (77 kg) (170 lbs.)	
Optional Ceiling Supply and Return Transitions — (Net weight)			SRT11-185 (32 kg) (70 lbs.)	SRT11-275 (36 kg) (80 lbs.)	
Optional Fresh Air Damper and Filter Size — mm (in.) — (Net weight)			OAD11-185 (41 kg) (90 lbs.) 1 — 635 x 686 x 25 (25 x 27 x 1)	OAD11-275 (52 kg) (115 lbs.) 1 — 660 x 787 x 25 (26 x 31 x 1)	
Optional Automatic Fresh Air Damper Kit — (Net weight)			99C94 (7 kg) (15 lbs.)	99C94 (7 kg) (15 lbs.)	
Optional Remote Status Panel			SP11 (12F83)	SP11 (12F83)	
Optional Remote Switching Status Panel			SSP11 (12F84)	SSP11 (12F84)	

\*Rated at Air-Conditioning and Refrigeration Institute (ARI) Standard 340 conditions; 60 L/s indoor air volume per kW of cooling capacity (450 cfm per ton).

**Cooling Ratings** — 35°C (95°F) outdoor air temperature, 27°C (80°F) dry bulb and 19.4°C (67°F) wet bulb entering indoor coil air.

**High Temperature Heating Ratings** — 8°C (47°F) dry bulb, 6.1°C (43°F) wet bulb outdoor air temperature and 21°C (70°F) entering indoor coil air.

**Low Temperature Heating Ratings** — minus 8°C (17°F) dry bulb, minus 9.4°C (15°F) wet bulb outdoor air temperature and 21°C (70°F) entering indoor coil air.

\*\*Rated at 82°C (180°F) supply water temperature, 21°C (70°F) entering air temperature, 11°C (20°F) water temperature drop and 60 L/s air volume per kW of cooling capacity (450 cfm per ton). See hot water capacity curves for heating capacities at other conditions.

## FIELD WIRING

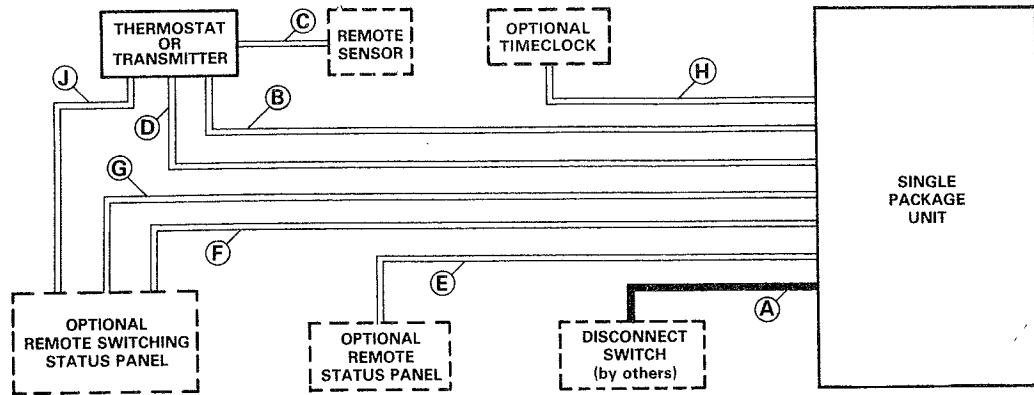

- |   |   |
|---|---|
| <p>A — Three phase power (See Electrical Data Table)</p> <p>B — Eight wire 24 volt — DC<br/>Five wire 24 volt — DC (with Remote Switching Status Panel Only)</p> <p>C — Two wire 24 volt — DC (with transmitter)</p> <p>D — Two wire 24 volt — AC (with switching subbase)<br/>One wire 24 volt — DC (with switching subbase)</p> | <p>E — Nine wire 24 volt — AC</p> <p>F — Twelve wire 24 volt — AC</p> <p>G — Four wire 24 volt — DC</p> <p>H — Three wire 24 volt — AC</p> <p>J — Two wire 24 volt — DC</p> |
|---|---|

AC — Alternating current  
DC — Direct current

— Note — Field wiring not furnished —

NOTE — All wiring must conform to local electrical codes. Run separate harnesses for AC and DC. AC voltage interferes with DC signals.

### CHP11-953 AND CHP11-1353 ELECTRICAL DATA — 50 Hz

Model Number		CHP11-953		CHP11-1353	
Line voltage (50 Hz — 3 phase with neutral)		380/420V		380/420V	
Voltage range (minimum — maximum)		342-462V		342-462V	
Compressor 1	Rated load (A)	8.2		12.3	
	Locked rotor (A)	37.0		66.0	
Compressor 2	Rated load (A)	8.2		11.7	
	Locked rotor (A)	45.0		66.0	
Outdoor Coil Fan Motors (1 Phase)	Full load (A)	(2) 1.1		(2) 1.5	
	Locked rotor (A)	(2) 2.3		(2) 3.1	
Indoor Coil Blower Motor	Output — kW (hp)	1.1 (1-1/2)	2.2 (3)	2.2 (3)	3.7 (5)
	Full load (A)	2.7	5.0	5.0	7.8
	Locked rotor (A)	17.0	28.0	28.0	50.0
Electric Heat — Per Element (A)		15.7		15.7	

NOTE — Refer to local electrical codes to determine wire, fuse and disconnect size requirements. Use wires suitable for at least 75°C (167°F).

### CHP11-1853 AND CHP11-2753 ELECTRICAL DATA — 50 Hz

Model Number		CHP11-1853		CHP11-2753	
Line voltage (50 Hz — 3 phase)		380/420V		380/420V	
Voltage range (minimum — maximum)		342-462V		342-462V	
Compressor 1	Rated load (A)	10.0		20.4	
	Locked rotor (A)	63.0		111.0	
Compressor 2	Rated load (A)	20.4		20.4	
	Locked rotor (A)	111.0		111.0	
Outdoor Coil Fan Motors (1 Phase)	Full load (A)	(1) 1.4 and (1) 1.9		(2) 1.9	
	Locked rotor (A)	(1) 3.1 and (1) 3.7		(2) 3.7	
Indoor Coil Blower Motor	Output — kW (hp)	3.7 (5)		3.7 (5)	5.6 (7-1/2)
	Full load (A)	7.8		7.8	11.8
	Locked rotor (A)	50.0		50.0	79.5
Optional Exhaust Fan Motors (1 phase)	Full load (A)	(2) 0.7		(3) 0.7	
	Locked rotor (A)	(2) 1.3		(3) 1.3	
Electric Heat Per Element (A)	ECH11-185-20	10.5		----	
	All others	15.7		15.7	

NOTE — Refer to local electrical codes to determine wire, fuse and disconnect size requirements. Use wires suitable for at least 75°C (167°F).

**CHP11-953 AND CHP11-1353 OPTIONAL ELECTRIC HEAT DATA**

Unit Model Number	Electric Heat Model Number and Shipping Weight	Number of Elements	Number of Steps	Volts Input	Heating Capacity	
					kW	Btuh
*CHP11-953	ECH11-95-15 24 kg (52 lbs.)	1	1	380	9.4	32 100
				400	10.4	35 500
				415	11.2	38 200
	ECH11-95-30 25 kg (56 lbs.)	2	1	380	18.8	64 100
				400	20.8	71 000
				415	22.4	76 400
	ECH11-95-45 27 kg (59 lbs.)	3	2	380	28.2	96 200
				400	31.3	106 800
				415	33.6	114 600
CHP11-1353	ECH11-135-15 24 kg (52 lbs.)	1	1	380	9.4	32 100
				400	10.4	35 500
				415	11.2	38 200
	ECH11-135-30 25 kg (56 lbs.)	2	1	380	18.8	64 100
				400	20.8	71 000
				415	22.4	76 400
	ECH11-135-45 27 kg (59 lbs.)	3	2	380	28.2	96 200
				400	31.3	106 800
				415	33.6	114 600

\*Electric heat not available with 1.1 kW (1-1/2 hp) motor.

**CHP11-1853 AND CHP11-2753 OPTIONAL ELECTRIC HEAT DATA**

Unit Model Number	Electric Heat Model Number and Shipping Weight	Number of Elements	Number of Steps	Volts Input	Heating Capacity	
					kW	Btuh
CHP11-1853	ECH11-185-20 61 kg (135 lbs.)	2	1	380	12.5	42 700
				400	13.9	47 400
				415	15.0	51 200
	ECH11-185-30 61 kg (135 lbs.)	2	1	380	18.8	64 200
				400	20.8	71 000
				415	22.4	76 400
	ECH11-185-45 66 kg (145 lbs.)	3	2	380	28.2	96 200
				400	31.3	106 800
				415	33.6	114 600
	ECH11-185-60 66 kg (145 lbs.)	4	2	380	37.6	128 300
				400	41.7	142 300
				415	45.0	153 500
CHP11-2753	ECH11-275-30 61 kg (135 lbs.)	2	1	380	18.8	64 200
				400	20.8	71 000
				415	22.4	76 400
	ECH11-275-45 66 kg (145 lbs.)	3	2	380	28.2	96 200
				400	31.3	106 800
				415	33.6	114 600
	ECH11-275-60 66 kg (145 lbs.)	4	2	380	37.6	128 300
				400	41.7	142 300
				415	45.0	153 500
	ECH11-275-75 70 kg (155 lbs.)	5	3	380	47.0	160 400
				400	52.1	177 800
				415	56.1	191 400

## RATINGS

NOTE — To determine sensible capacity, leaving wet bulb and dry bulb temperatures not shown in the tables, see Miscellaneous Engineering Data section, page 1

### CHP11-953 COOLING CAPACITY — 50 Hz (With One Compressor Only Operating)

Entering Wet Bulb Temperature	Total Air Volume		Outdoor Temperature																							
			18°C (65°F)						24°C (75°F)						29°C (85°F)						35°C (95°F)					
			Total Cooling Capacity		Compressor Motor Input	Sensible To Total Ratio (S/T)			Total Cooling Capacity		Compressor Motor Input	Sensible To Total Ratio (S/T)			Total Cooling Capacity		Compressor Motor Input	Sensible To Total Ratio (S/T)			Total Cooling Capacity		Compressor Motor Input	Sensible To Total Ratio (S/T)		
						Dry Bulb						Dry Bulb						Dry Bulb						Dry Bulb		
m <sup>3</sup> /s	cfm	kW	Btuh	kW	24°C 76°F	27°C 80°F	29°C 84°F	kW	Btuh	kW	24°C 76°F	27°C 80°F	29°C 84°F	kW	Btuh	kW	24°C 76°F	27°C 80°F	29°C 84°F	kW	Btuh	kW	24°C 76°F	27°C 80°F	29°C 84°F	
17.2°C (63°F)	1.30	2750	12.7	43 200	3.14	.76	.88	1.00	12.1	41 200	3.42	.78	.91	1.00	11.5	39 200	3.68	.80	.93	1.00	10.9	37 200	3.94	.83	1.00	1.00
	1.45	3100	12.9	44 100	3.17	.80	.93	1.00	12.3	42 000	3.45	.82	1.00	1.00	11.8	40 200	3.73	.84	1.00	1.00	11.3	38 400	4.00	.87	1.00	1.00
	1.65	3450	13.2	44 900	3.21	.83	1.00	1.00	12.6	43 100	3.50	.86	1.00	1.00	12.1	41 200	3.78	.88	1.00	1.00	11.5	39 400	4.06	.91	1.00	1.00
19.4°C (67°F)	1.30	2750	13.4	45 800	3.23	.59	.71	.82	12.8	43 700	3.52	.60	.73	.85	12.1	41 400	3.79	.62	.75	.87	11.5	39 300	4.05	.63	.77	.90
	1.45	3100	13.6	46 500	3.26	.61	.74	.87	13.0	44 300	3.54	.63	.76	.89	12.3	42 100	3.82	.64	.78	.92	11.7	39 800	4.08	.66	.81	1.00
	1.65	3450	13.8	47 100	3.28	.64	.78	.91	13.1	44 800	3.57	.65	.80	.93	12.5	42 600	3.85	.67	.82	1.00	11.8	40 300	4.11	.69	.85	1.00
21.7°C (71°F)	1.30	2750	14.3	48 800	3.34	.44	.55	.66	13.6	46 500	3.63	.44	.58	.67	13.0	44 200	3.92	.45	.57	.69	12.3	41 900	4.19	.46	.58	.71
	1.45	3100	14.5	49 400	3.36	.45	.57	.69	13.8	47 100	3.66	.45	.58	.71	13.1	44 800	3.94	.46	.57	.73	12.4	42 400	4.21	.47	.61	.75
	1.65	3450	14.7	50 000	3.38	.46	.59	.72	14.0	47 600	3.67	.47	.61	.74	13.2	45 200	3.96	.47	.62	.77	12.5	42 800	4.23	.48	.64	.79

### CHP11-953 HEATING PERFORMANCE (With One Compressor Only Operating) — 50 Hz

Indoor Coil Air Volume at 21°C (70°F)	*Outdoor Temperature															
	18°C (65°F)				13°C (55°F)				7°C (45°F)				2°C (35°F)			
	Total Heating Capacity		Compressor Motor Input		Total Heating Capacity		Compressor Motor Input		Total Heating Capacity		Compressor Motor Input		Total Heating Capacity		Compressor Motor Input	
	m <sup>3</sup> /s	cfm	kW	Btuh	kW	kW	Btuh	kW	Btuh	kW	Btuh	kW	Btuh	kW	Btuh	kW
1.30	2750	14.6	49 700	3.48	13.0	44 400	3.18	11.4	39 000	2.88	8.7	29 800	2.57			
1.45	3100	14.9	50 900	3.44	13.3	45 400	3.14	11.7	39 800	2.85	8.9	30 400	2.55			
1.65	3450	15.2	51 900	3.40	13.6	46 300	3.12	11.9	40 600	2.82	9.1	31 000	2.52			

\*At 70% relative humidity.

NOTE — Heating performance includes the effect of defrost cycles in the temperature range where they occur.

### CHP11-953 COOLING CAPACITY — 50 Hz (With Both Compressors Operating)

Entering Wet Bulb Temperature	Total Air Volume		Outdoor Temperature																							
			29°C (85°F)						35°C (95°F)						41°C (105°F)						46°C (115°F)					
			Total Cooling Capacity		Compressor Motor Input	Sensible To Total Ratio (S/T)			Total Cooling Capacity		Compressor Motor Input	Sensible To Total Ratio (S/T)			Total Cooling Capacity		Compressor Motor Input	Sensible To Total Ratio (S/T)			Total Cooling Capacity		Compressor Motor Input	Sensible To Total Ratio (S/T)		
						Dry Bulb						Dry Bulb						Dry Bulb						Dry Bulb		
m <sup>3</sup> /s	cfm	kW	Btuh	kW	24°C 76°F	27°C 80°F	29°C 84°F	kW	Btuh	kW	24°C 76°F	27°C 80°F	29°C 84°F	kW	Btuh	kW	24°C 76°F	27°C 80°F	29°C 84°F	kW	Btuh	kW	24°C 76°F	27°C 80°F	29°C 84°F	
17.2°C (63°F)	1.30	2750	23.5	80 100	6.84	.81	.94	1.00	22.0	75 200	7.31	.83	1.00	1.00	21.1	71 900	7.76	.86	1.00	1.00	20.0	68 300	8.18	.89	1.00	1.00
	1.45	3100	23.9	81 700	6.91	.84	1.00	1.00	22.8	77 900	7.41	.87	1.00	1.00	21.7	74 100	7.88	.90	1.00	1.00	20.6	70 300	8.30	.93	1.00	1.00
	1.65	3450	24.6	83 800	7.01	.88	1.00	1.00	23.4	80 000	7.51	.91	1.00	1.00	22.3	76 000	7.99	.94	1.00	1.00	21.1	72 100	8.41	1.00	1.00	1.00
19.4°C (67°F)	1.30	2750	25.0	85 200	7.06	.62	.75	.87	23.6	80 600	7.54	.64	.77	.90	22.3	76 000	7.99	.65	.79	.93	21.0	71 500	8.37	.67	.82	.96
	1.45	3100	25.3	86 400	7.12	.65	.78	.92	24.0	82 000	7.60	.66	.80	.95	22.6	77 100	8.04	.68	.83	1.00	21.2	72 500	8.44	.70	.87	1.00
	1.65	3450	25.6	87 500	7.16	.67	.82	.96	24.3	82 800	7.65	.69	.85	1.00	22.9	78 100	8.10	.71	.88	1.00	21.5	73 500	8.49	.73	.91	1.00
21.7°C (71°F)	1.30	2750	26.7	91 200	7.31	.46	.58	.70	25.3	86 400	7.81	.46	.59	.71	23.9	81 500	8.27	.47	.60	.74	22.4	76 600	8.68	.48	.62	.76
	1.45	3100	27.1	92 300	7.36	.47	.60	.73	25.6	87 400	7.86	.48	.61	.75	24.2	82 500	8.32	.48	.63	.78	22.7	77 500	8.73	.49	.65	.80
	1.65	3450	27.3	93 300	7.40	.48	.62	.76	25.9	88 300	7.90	.49	.64	.79	24.4	83 300	8.37	.50	.66	.81	22.9	78 200	8.77	.51	.68	.85

### CHP11-953 HEATING PERFORMANCE (With Both Compressors Operating) — 50 Hz

Indoor Coil Air Volume at 21°C (70°F)	*Outdoor Temperature																			
	18°C (65°F)				7°C (45°F)				minus 4°C (25°F)				minus 15°C (5°F)				minus 26°C (minus 15°F)			
	Total Heating Capacity		Compressor Motor Input		Total Heating Capacity		Compressor Motor Input		Total Heating Capacity		Compressor Motor Input		Total Heating Capacity		Compressor Motor Input		Total Heating Capacity		Compressor Motor Input	
	m <sup>3</sup> /s	cfm	kW	Btuh	kW	kW	Btuh	kW	Btuh	kW	Btuh	kW	Btuh	kW	Btuh	kW	Btuh	kW	Btuh	kW
1.30	2750	28.4	96 800	7.50	22.1	75 300	6.20	14.0	47 900	5.16	9.0	30 800	3.93	6.2	21 200	3.13				
1.45	3100	28.9	98 700	7.41	22.4	76 400	6.13	14.3	48 800	5.13	9.2	31 500	3.92	6.3	21 600	3.13				
1.65	3450	29.4	100 400	7.33	22.7	77 600	6.06	14.5	49 500	5.07	9.4	32 100	3.91	6.4	22 000	3.12				

\*At 70% relative humidity.

NOTE — Heating performance includes the effect of defrost cycles in the temperature range where they occur.



## RATINGS

NOTE — To determine sensible capacity, leaving wet bulb and dry bulb temperatures not shown in the tables, see Miscellaneous Engineering Data section, page 1

### CHP11-1353 COOLING CAPACITY — 50 Hz (With One Compressor Only Operating)

Entering Wet Bulb Temperature	Total Air Volume		Outdoor Temperature																							
			18°C (65°F)						24°C (75°F)						29°C (85°F)						35°C (95°F)					
			Total Cooling Capacity		Compressor Motor Input	Sensible To Total Ratio (S/T)			Total Cooling Capacity		Compressor Motor Input	Sensible To Total Ratio (S/T)			Total Cooling Capacity		Compressor Motor Input	Sensible To Total Ratio (S/T)			Total Cooling Capacity		Compressor Motor Input	Sensible To Total Ratio (S/T)		
						Dry Bulb						Dry Bulb						Dry Bulb						Dry Bulb		
m <sup>3</sup> /s	cfm	kW	Btuh	kW	24°C 76°F	27°C 80°F	29°C 84°F	kW	Btuh	kW	24°C 76°F	27°C 80°F	29°C 84°F	kW	Btuh	kW	24°C 76°F	27°C 80°F	29°C 84°F	kW	Btuh	kW	24°C 76°F	27°C 80°F	29°C 84°F	
17.2°C (63°F)	1.75	3700	17.7	60 400	4.18	.78	.91	1.00	16.9	57 500	4.51	.80	.93	1.00	16.0	54 600	4.85	.82	.96	1.00	15.2	51 700	5.17	.85	1.00	1.00
	1.95	4150	18.0	61 500	4.23	.82	.95	1.00	17.2	58 800	4.56	.84	.97	1.00	16.3	55 700	4.90	.86	1.00	1.00	15.6	53 200	5.25	.89	1.00	1.00
	2.15	4600	18.3	62 400	4.26	.85	1.00	1.00	17.5	59 800	4.61	.87	1.00	1.00	16.7	57 100	4.97	.90	1.00	1.00	16.0	54 500	5.31	.93	1.00	1.00
19.4°C (67°F)	1.75	3700	18.8	64 100	4.32	.61	.73	.84	17.8	60 900	4.66	.62	.75	.87	16.9	57 800	5.00	.63	.77	.89	16.1	54 800	5.33	.65	.79	.92
	1.95	4150	19.0	64 900	4.36	.63	.76	.89	18.1	61 700	4.69	.65	.78	.91	17.1	58 500	5.03	.66	.80	.94	16.3	55 500	5.37	.68	.83	.97
	2.15	4600	19.3	65 700	4.39	.65	.79	.93	18.3	62 400	4.73	.67	.82	.96	17.3	59 200	5.07	.69	.84	1.00	16.5	56 200	5.40	.70	.87	1.00
21.7°C (71°F)	1.75	3700	20.0	68 100	4.47	.45	.57	.68	19.0	64 800	4.82	.46	.58	.69	18.1	61 600	5.17	.47	.59	.71	17.1	58 400	5.51	.47	.60	.73
	1.95	4150	20.2	68 900	4.50	.46	.59	.71	19.2	65 500	4.85	.47	.60	.73	18.2	62 200	5.20	.48	.61	.75	17.3	59 000	5.54	.48	.63	.77
	2.15	4600	20.4	69 600	4.53	.47	.61	.74	19.4	66 200	4.88	.48	.62	.76	18.4	62 800	5.23	.49	.64	.78	17.4	59 500	5.57	.50	.65	.81

### CHP11-1353 HEATING PERFORMANCE (With One Compressor Only Operating) — 50 Hz

Indoor Coil Air Volume at 21°C (70°F)	*Outdoor Temperature															
	18°C (65°F)				13°C (55°F)				7°C (45°F)				2°C (35°F)			
	Total Heating Capacity		Compressor Motor Input	Total Heating Capacity		Compressor Motor Input	Total Heating Capacity		Compressor Motor Input	Total Heating Capacity		Compressor Motor Input	Total Heating Capacity		Compressor Motor Input	
																kW
m <sup>3</sup> /s	cfm	kW	Btuh	kW	Btuh	kW	Btuh	kW	Btuh	kW	Btuh	kW	Btuh	kW		
1.75	3700	20.0	68 200	4.95	17.9	61 100	4.58	15.9	54 200	4.17	12.1	41 200	3.83			
1.95	4150	20.4	69 600	4.83	18.3	62 400	4.47	16.2	55 400	4.11	12.4	42 200	3.78			
2.15	4600	20.8	70 900	4.73	18.6	63 600	4.38	16.5	56 400	4.07	12.6	43 100	3.74			

\*At 70% relative humidity.

NOTE — Heating performance includes the effect of defrost cycles in the temperature range where they occur.

### CHP11-1353 COOLING CAPACITY — 50 Hz (With Both Compressors Operating)

Entering Wet Bulb Temperature	Total Air Volume		Outdoor Temperature																							
			29°C (85°F)						35°C (95°F)						41°C (105°F)						46°C (115°F)					
			Total Cooling Capacity		Compressor Motor Input	Sensible To Total Ratio (S/T)			Total Cooling Capacity		Compressor Motor Input	Sensible To Total Ratio (S/T)			Total Cooling Capacity		Compressor Motor Input	Sensible To Total Ratio (S/T)			Total Cooling Capacity		Compressor Motor Input	Sensible To Total Ratio (S/T)		
						Dry Bulb						Dry Bulb						Dry Bulb						Dry Bulb		
m <sup>3</sup> /s	cfm	kW	Btuh	kW	24°C 76°F	27°C 80°F	29°C 84°F	kW	Btuh	kW	24°C 76°F	27°C 80°F	29°C 84°F	kW	Btuh	kW	24°C 76°F	27°C 80°F	29°C 84°F	kW	Btuh	kW	24°C 76°F	27°C 80°F	29°C 84°F	
17.2°C (63°F)	1.75	3700	31.6	107 800	9.63	.82	.95	1.00	29.7	101 300	10.28	.84	1.00	1.00	28.5	97 200	10.95	.86	1.00	1.00	27.2	92 700	11.59	.89	1.00	1.00
	1.95	4150	32.1	109 600	9.72	.85	1.00	1.00	30.7	104 800	10.42	.88	1.00	1.00	29.3	99 900	11.10	.90	1.00	1.00	27.9	95 200	11.74	.93	1.00	1.00
	2.15	4600	32.9	112 400	9.85	.89	1.00	1.00	31.5	107 400	10.55	.91	1.00	1.00	30.0	102 300	11.24	.94	1.00	1.00	28.5	97 300	11.89	1.00	1.00	1.00
19.4°C (67°F)	1.75	3700	33.6	114 500	9.95	.63	.76	.88	31.8	108 400	10.61	.64	.78	.91	30.1	102 600	11.26	.66	.80	.94	28.4	97 000	11.85	.68	.83	.97
	1.95	4150	34.0	116 000	10.01	.65	.79	.93	32.2	110 000	10.68	.67	.80	.96	30.4	103 800	11.33	.69	.84	1.00	28.8	98 200	11.92	.71	.87	1.00
	2.15	4600	34.3	117 200	10.08	.68	.83	.97	32.6	111 100	10.75	.69	.85	1.00	30.8	105 100	11.40	.71	.88	1.00	29.1	99 300	12.00	.73	.91	1.00
21.7°C (71°F)	1.75	3700	35.8	122 100	10.30	.46	.58	.70	33.9	115 800	10.98	.47	.60	.72	32.1	109 700	11.64	.48	.61	.75	30.4	103 600	12.25	.48	.63	.77
	1.95	4150	36.2	123 500	10.36	.47	.61	.74	34.3	117 100	11.04	.48	.62	.76	32.5	110 800	11.70	.49	.64	.78	30.7	104 600	12.31	.50	.65	.81
	2.15	4600	36.5	124 700	10.42	.48	.63	.77	34.6	118 200	11.10	.49	.64	.79	32.8	111 800	11.75	.50	.66	.82	30.9	105 500	12.36	.51	.68	.85

### CHP11-1353 HEATING PERFORMANCE (With Both Compressors Operating) — 50 Hz

Indoor Coil Air Volume at 21°C (70°F)	*Outdoor Temperature																			
	18°C (65°F)				7°C (45°F)				minus 4°C (25°F)				minus 15°C (5°F)				minus 26°C (minus 15°F)			
	Total Heating Capacity		Compressor Motor Input	Total Heating Capacity		Compressor Motor Input	Total Heating Capacity		Compressor Motor Input	Total Heating Capacity		Compressor Motor Input	Total Heating Capacity		Compressor Motor Input	Total Heating Capacity		Compressor Motor Input		
																			kW	Btuh
m <sup>3</sup> /s	cfm	kW	Btuh	kW	Btuh	kW	Btuh	kW	Btuh	kW	Btuh	kW	Btuh	kW	Btuh	kW	Btuh	kW		
1.75	3700	38.8	132 400	9.72	30.6	104 400	8.25	19.0	64 800	6.97	12.9	43 900	5.52	8.9	30 400	4.55				
1.95	4150	39.4	134 600	9.48	31.1	106 200	8.22	19.3	66 000	6.88	13.2	44 900	5.50	9.1	31 200	4.53				
2.15	4600	40.0	136 800	9.28	31.6	107 700	8.13	19.7	67 200	6.83	13.4	45 800	5.48	9.3	31 900	4.52				

\*At 70% relative humidity.

NOTE — Heating performance includes the effect of defrost cycles in the temperature range where they occur.

## RATINGS

NOTE — To determine sensible capacity, leaving wet bulb and dry bulb temperatures not shown in the tables, see Miscellaneous Engineering Data section, page 1

### CHP11-1853 COOLING CAPACITY — 50 Hz (With First Compressor Only Operating)

Entering Wet Bulb Temperature	Total Air Volume		Outdoor Temperature																							
			18°C (65°F)						24°C (75°F)						29°C (85°F)						35°C (95°F)					
			Total Cooling Capacity		Compressor Motor Input	Sensible To Total Ratio (S/T)			Total Cooling Capacity		Compressor Motor Input	Sensible To Total Ratio (S/T)			Total Cooling Capacity		Compressor Motor Input	Sensible To Total Ratio (S/T)			Total Cooling Capacity		Compressor Motor Input	Sensible To Total Ratio (S/T)		
						Dry Bulb						Dry Bulb						Dry Bulb						Dry Bulb		
			m <sup>3</sup> /s	cfm	kW	Btuh	kW	24°C 76°F	27°C 80°F	29°C 84°F	kW	Btuh	kW	24°C 76°F	27°C 80°F	29°C 84°F	kW	Btuh	kW	24°C 76°F	27°C 80°F	29°C 84°F	kW	Btuh	kW	24°C 76°F
17.2°C (63°F)	2.60	5500	17.2	58 700	4.02	.77	.89	1.00	16.4	55 800	4.34	.79	.91	1.00	15.5	53 000	4.66	.81	.94	1.00	14.8	50 400	4.98	.83	.96	1.00
	2.95	6200	17.5	59 700	4.06	.80	.92	1.00	16.6	56 800	4.38	.82	.95	1.00	15.9	54 100	4.71	.84	.98	1.00	15.0	51 300	5.03	.86	1.00	1.00
	3.25	6900	17.8	60 800	4.10	.83	.96	1.00	16.8	57 400	4.42	.85	1.00	1.00	16.1	55 100	4.76	.87	1.00	1.00	15.4	52 700	5.10	.90	1.00	1.00
19.4°C (67°F)	2.60	5500	18.3	62 600	4.16	.60	.71	.83	17.4	59 500	4.49	.61	.73	.85	16.6	56 500	4.82	.62	.75	.87	15.7	53 600	5.15	.64	.77	.90
	2.95	6200	18.6	63 400	4.20	.62	.74	.86	17.7	60 300	4.53	.63	.76	.89	16.8	57 300	4.86	.65	.78	.91	15.9	54 400	5.19	.66	.80	.94
	3.25	6900	18.8	64 200	4.23	.64	.77	.90	17.9	61 100	4.56	.65	.79	.93	17.0	58 000	4.89	.67	.81	.95	16.1	55 000	5.22	.68	.84	.98
21.7°C (71°F)	2.60	5500	19.5	66 700	4.32	.45	.56	.66	18.6	63 500	4.66	.46	.57	.68	17.7	60 400	5.00	.46	.58	.69	16.8	57 400	5.34	.47	.59	.71
	2.95	6200	19.8	67 500	4.35	.46	.58	.69	18.8	64 300	4.69	.47	.59	.71	17.9	61 100	5.03	.47	.60	.73	17.0	58 100	5.37	.48	.61	.75
	3.25	6900	20.0	68 300	4.37	.47	.59	.72	19.0	65 000	4.72	.48	.61	.74	18.1	61 800	5.06	.48	.62	.76	17.2	58 700	5.40	.49	.63	.78

### CHP11-1853 HEATING PERFORMANCE (With First Compressor Only Operating) — 50 Hz

Indoor Coil Air Volume at 21°C (70°F)	*Outdoor Temperature																					
	18°C (65°F)				13°C (55°F)				7°C (45°F)				2°C (35°F)									
	Total Heating Capacity		Compressor Motor Input		Total Heating Capacity		Compressor Motor Input		Total Heating Capacity		Compressor Motor Input		Total Heating Capacity		Compressor Motor Input							
	m <sup>3</sup> /s	cfm	kW	Btuh	kW	Btuh	kW	Btuh	kW	Btuh	kW	Btuh	kW	Btuh	kW	Btuh						
2.60	5500	20.8	71 000	4.67	18.9	64 500	4.30	16.7	57 000	3.97	13.1	44 700	3.63	13.2	45 200	3.60	13.3	45 500	3.56	13.3	45 500	3.56
2.95	6200	21.0	71 600	4.62	19.0	65 000	4.26	16.9	57 500	3.93	13.2	45 200	3.60	13.2	45 200	3.60	13.2	45 200	3.60	13.2	45 200	3.60
3.25	6900	21.2	72 200	4.58	19.2	65 600	4.23	17.0	58 100	3.89	13.3	45 500	3.56	13.3	45 500	3.56	13.3	45 500	3.56	13.3	45 500	3.56

\*At 70% relative humidity.

NOTE — Heating performance includes the effect of defrost cycles in the temperature range where they occur.

### CHP11-1853 COOLING CAPACITY — 50 Hz (With Second Compressor Only Operating)

Entering Wet Bulb Temperature	Total Air Volume		Outdoor Temperature																							
			18°C (65°F)						24°C (75°F)						29°C (85°F)						35°C (95°F)					
			Total Cooling Capacity		Compressor Motor Input	Sensible To Total Ratio (S/T)			Total Cooling Capacity		Compressor Motor Input	Sensible To Total Ratio (S/T)			Total Cooling Capacity		Compressor Motor Input	Sensible To Total Ratio (S/T)			Total Cooling Capacity		Compressor Motor Input	Sensible To Total Ratio (S/T)		
						Dry Bulb						Dry Bulb						Dry Bulb						Dry Bulb		
			m <sup>3</sup> /s	cfm	kW	Btuh	kW	24°C 76°F	27°C 80°F	29°C 84°F	kW	Btuh	kW	24°C 76°F	27°C 80°F	29°C 84°F	kW	Btuh	kW	24°C 76°F	27°C 80°F	29°C 84°F	kW	Btuh	kW	24°C 76°F
17.2°C (63°F)	2.60	5500	34.2	116 800	7.89	.77	.89	1.00	32.7	111 700	8.59	.79	.91	1.00	31.2	106 500	9.24	.80	.93	1.00	29.6	101 100	9.84	.83	.96	1.00
	2.95	6200	34.9	119 200	7.98	.80	.93	1.00	33.4	114 100	8.68	.82	.95	1.00	31.9	108 800	9.33	.84	.97	1.00	30.2	103 000	9.93	.86	1.00	1.00
	3.25	6900	35.7	121 700	8.07	.83	.96	1.00	33.8	115 400	8.75	.85	1.00	1.00	32.5	110 900	9.43	.87	1.00	1.00	31.0	105 800	10.06	.90	1.00	1.00
19.4°C (67°F)	2.60	5500	36.8	125 700	8.21	.60	.71	.82	35.1	119 900	8.91	.61	.73	.84	33.4	113 900	9.56	.62	.75	.87	31.6	107 800	10.15	.64	.77	.89
	2.95	6200	37.5	127 800	8.28	.62	.74	.86	35.7	121 800	8.98	.63	.76	.88	33.9	115 600	9.63	.64	.78	.91	32.1	109 400	10.22	.66	.80	.94
	3.25	6900	38.0	129 700	8.35	.64	.77	.90	36.2	123 500	9.04	.65	.79	.92	34.3	117 200	9.69	.66	.81	.95	32.5	110 800	10.28	.68	.83	.98
21.7°C (71°F)	2.60	5500	39.6	135 100	8.53	.45	.55	.66	37.8	128 900	9.24	.46	.56	.67	35.8	122 200	9.90	.46	.58	.69	33.8	115 500	10.49	.47	.59	.71
	2.95	6200	40.2	137 300	8.60	.46	.57	.68	38.3	130 700	9.31	.46	.58	.70	36.3	123 900	9.96	.47	.60	.72	34.3	116 900	10.55	.48	.61	.74
	3.25	6900	40.7	139 000	8.66	.47	.59	.71	38.8	132 400	9.37	.47	.60	.73	36.7	125 300	10.02	.48	.62	.75	34.6	118 200	10.60	.49	.63	.78

### CHP11-1853 HEATING PERFORMANCE (With Second Compressor Only Operating) — 50 Hz

Indoor Coil Air Volume at 21°C (70°F)	*Outdoor Temperature																					
	18°C (65°F)				13°C (55°F)				7°C (45°F)				2°C (35°F)									
	Total Heating Capacity		Compressor Motor Input		Total Heating Capacity		Compressor Motor Input		Total Heating Capacity		Compressor Motor Input		Total Heating Capacity		Compressor Motor Input							
	m <sup>3</sup> /s	cfm	kW	Btuh	kW	Btuh	kW	Btuh	kW	Btuh	kW	Btuh	kW	Btuh	kW	Btuh						
2.60	5500	42.3	144 500	9.58	36.0	123 000	8.92	30.5	104 100	8.17	25.5	86 900	7.46	25.7	87 700	7.38	26.0	88 600	7.29	26.0	88 600	7.29
2.95	6200	42.7	145 800	9.50	36.4	124 200	8.83	30.8	105 100	8.08	25.7	87 700	7.38	26.0	88 600	7.29	26.0	88 600	7.29	26.0	88 600	7.29
3.25	6900	43.2	147 500	9.42	36.8	125 500	8.75	31.1	106 100	8.00	26.0	88 600	7.29	26.0	88 600	7.29	26.0	88 600	7.29	26.0	88 600	7.29

\*At 70% relative humidity.

NOTE — Heating performance includes the effect of defrost cycles in the temperature range where they occur.

## RATINGS

NOTE — To determine Sensible Capacity, Leaving Wet Bulb and Dry Bulb temperatures not shown in the cooling table see Miscellaneous Engineering Data section, Page 1

### CHP11-1853 COOLING CAPACITY — 50 Hz (With Both Compressors Operating)

Entering Wet Bulb Temperature	Total Air Volume		Outdoor Temperature																							
			29°C (85°F)						35°C (95°F)						41°C (105°F)						46°C (115°F)					
			Total Cooling Capacity		Compressor Motor Input	Sensible To Total Ratio (S/T)			Total Cooling Capacity		Compressor Motor Input	Sensible To Total Ratio (S/T)			Total Cooling Capacity		Compressor Motor Input	Sensible To Total Ratio (S/T)			Total Cooling Capacity		Compressor Motor Input	Sensible To Total Ratio (S/T)		
						Dry Bulb						Dry Bulb						Dry Bulb						Dry Bulb		
m <sup>3</sup> /s	cfm	kW	Btuh	kW	24°C 76°F	27°C 80°F	29°C 84°F	kW	Btuh	kW	24°C 76°F	27°C 80°F	29°C 84°F	kW	Btuh	kW	24°C 76°F	27°C 80°F	29°C 84°F	kW	Btuh	kW	24°C 76°F	27°C 80°F	29°C 84°F	
17.2°C (63°F)	2.60	5500	46.8	159 700	13.86	.78	.90	1.00	44.5	151 700	14.76	.80	.93	1.00	41.8	142 600	15.56	.83	1.00	1.00	39.6	135 100	16.31	.86	1.00	1.00
	2.95	6200	47.8	163 100	14.00	.81	.95	1.00	45.2	154 300	14.91	.84	1.00	1.00	43.0	146 700	15.77	.86	1.00	1.00	40.7	138 900	16.51	.90	1.00	1.00
	3.25	6900	48.7	166 300	14.14	.85	1.00	1.00	46.5	158 600	15.10	.87	1.00	1.00	44.1	150 500	15.96	.90	1.00	1.00	41.7	142 300	16.68	.94	1.00	1.00
19.4°C (67°F)	2.60	5500	50.1	170 900	14.34	.60	.72	.84	47.4	161 600	15.24	.62	.74	.87	44.5	152 000	16.03	.63	.77	.90	41.7	142 300	16.68	.65	.79	.93
	2.95	6200	50.8	173 400	14.44	.62	.75	.88	48.0	164 000	15.34	.64	.78	.91	45.1	154 000	16.13	.66	.80	.94	42.2	144 100	16.78	.68	.83	1.00
	3.25	6900	51.5	175 700	14.54	.64	.78	.92	48.6	165 900	15.43	.66	.81	.95	45.7	155 900	16.22	.68	.84	1.00	42.7	145 800	16.87	.71	.87	1.00
21.7°C (71°F)	2.60	5500	53.8	183 500	14.84	.45	.56	.67	50.8	173 200	15.74	.45	.57	.69	47.7	162 700	16.53	.46	.59	.71	44.5	151 900	17.17	.47	.60	.74
	2.95	6200	54.5	185 900	14.94	.46	.58	.70	51.4	175 300	15.83	.46	.59	.72	48.2	164 600	16.61	.47	.61	.75	45.0	153 500	17.25	.48	.63	.78
	3.25	6900	55.1	188 000	15.03	.47	.60	.73	51.9	177 200	15.91	.47	.61	.75	48.7	166 200	16.69	.48	.63	.78	45.4	155 000	17.32	.50	.66	.81

### CHP11-1853 HEATING PERFORMANCE (With Both Compressors Operating) — 50 Hz

Indoor Coil Air Volume at 21°C (70°F)	*Outdoor Temperature																			
	18°C (65°F)				7°C (45°F)				minus 4°C (25°F)				minus 15°C (5°F)				minus 26°C (minus 15°F)			
	Total Heating Capacity		Compressor Motor Input		Total Heating Capacity		Compressor Motor Input		Total Heating Capacity		Compressor Motor Input		Total Heating Capacity		Compressor Motor Input		Total Heating Capacity		Compressor Motor Input	
	m <sup>3</sup> /s	cfm	kW	Btuh	kW	kW	Btuh	kW	Btuh	kW	Btuh	kW	Btuh	kW	Btuh	kW	Btuh	kW	Btuh	kW
2.60	5500	61.4	209 400	14.25	45.4	154 800	12.13	31.0	105 800	9.67	26.2	89 300	9.25	15.6	53 200	6.91	15.9	54 300	6.78	
2.95	6200	61.9	211 100	14.12	45.8	156 400	12.01	31.3	106 800	9.58	26.4	90 100	9.17	15.8	53 800	6.84	15.9	54 300	6.78	
3.25	6900	62.6	213 700	13.99	46.3	158 000	11.89	31.6	107 800	9.50	26.7	91 000	9.08	15.9	54 300	6.78	15.9	54 300	6.78	

\*At 70% relative humidity.

NOTE — Heating performance includes the effect of defrost cycles in the temperature range where they occur.

### CHP11-2753 COOLING CAPACITY — 50 Hz (With One Compressor Only Operating)

Entering Wet Bulb Temperature	Total Air Volume		Outdoor Temperature																							
			18°C (65°F)						24°C (75°F)						29°C (85°F)						35°C (95°F)					
			Total Cooling Capacity		Compressor Motor Input	Sensible To Total Ratio (S/T)			Total Cooling Capacity		Compressor Motor Input	Sensible To Total Ratio (S/T)			Total Cooling Capacity		Compressor Motor Input	Sensible To Total Ratio (S/T)			Total Cooling Capacity		Compressor Motor Input	Sensible To Total Ratio (S/T)		
						Dry Bulb						Dry Bulb						Dry Bulb						Dry Bulb		
m <sup>3</sup> /s	cfm	kW	Btuh	kW	24°C 76°F	27°C 80°F	29°C 84°F	kW	Btuh	kW	24°C 76°F	27°C 80°F	29°C 84°F	kW	Btuh	kW	24°C 76°F	27°C 80°F	29°C 84°F	kW	Btuh	kW	24°C 76°F	27°C 80°F	29°C 84°F	
17.2°C (63°F)	3.40	7200	34.6	118 200	7.86	.76	.88	1.00	33.2	113 200	8.55	.78	.90	1.00	31.6	107 800	9.20	.80	.92	1.00	30.0	102 400	9.81	.82	.95	1.00
	3.85	8200	35.5	121 000	7.96	.79	.92	1.00	34.0	115 900	8.64	.81	.94	1.00	32.2	109 800	9.28	.83	1.00	1.00	30.7	104 900	9.92	.86	1.00	1.00
	4.35	9200	36.3	123 900	8.04	.83	.96	1.00	34.6	118 200	8.74	.85	1.00	1.00	33.2	113 200	9.43	.87	1.00	1.00	31.7	108 000	10.06	.90	1.00	1.00
19.4°C (67°F)	3.40	7200	37.2	127 000	8.16	.59	.70	.81	35.5	121 300	8.86	.60	.72	.83	33.7	115 100	9.51	.61	.74	.86	31.9	109 000	10.10	.63	.76	.89
	3.85	8200	37.9	129 400	8.24	.61	.74	.86	36.1	123 300	8.94	.62	.75	.88	34.3	117 000	9.59	.64	.77	.90	32.4	110 700	10.18	.65	.80	.93
	4.35	9200	38.5	131 500	8.31	.63	.77	.90	36.7	125 200	9.00	.65	.79	.92	34.8	118 700	9.65	.66	.81	.95	32.9	112 100	10.25	.68	.84	1.00
21.7°C (71°F)	3.40	7200	40.1	136 700	8.48	.44	.55	.65	38.2	130 200	9.19	.45	.56	.67	36.2	123 600	9.84	.45	.57	.68	34.2	116 700	10.44	.46	.58	.70
	3.85	8200	40.7	139 000	8.56	.45	.57	.68	38.7	132 200	9.26	.46	.58	.70	36.7	125 300	9.91	.46	.59	.72	34.6	118 200	10.50	.47	.61	.74
	4.35	9200	41.3	140 900	8.62	.46	.59	.71	39.3	134 000	9.32	.47	.60	.73	37.2	126 900	9.97	.48	.62	.75	35.1	119 600	10.56	.49	.63	.78

### CHP11-2753 HEATING PERFORMANCE (With One Compressor Only Operating) — 50 Hz

Indoor Coil Air Volume at 21°C (70°F)	*Outdoor Temperature															
	18°C (65°F)				13°C (55°F)				7°C (45°F)				2°C (35°F)			
	Total Heating Capacity		Compressor Motor Input		Total Heating Capacity		Compressor Motor Input		Total Heating Capacity		Compressor Motor Input		Total Heating Capacity		Compressor Motor Input	
	m <sup>3</sup> /s	cfm	kW	Btuh	kW	kW	Btuh	kW	Btuh	kW	Btuh	kW	Btuh	kW	Btuh	kW
3.40	7200	42.3	144 300	9.42	36.0	123 000	8.71	30.5	104 100	8.04	25.5	86 900	7.38			
3.85	8200	42.7	145 800	9.33	36.4	124 200	8.63	30.8	105 100	7.96	25.7	87 700	7.30			
4.35	9200	43.1	147 100	9.25	36.8	125 400	8.54	31.1	106 100	7.88	26.0	88 600	7.23			

\*At 70% relative humidity.

NOTE — Heating performance includes the effect of defrost cycles in the temperature range where they occur.

## RATINGS

NOTE — To determine Sensible Capacity, Leaving Wet Bulb and Dry Bulb temperatures not shown in the cooling table see Miscellaneous Engineering Data section, Page 1

### CHP11-2753 COOLING CAPACITY — 50 Hz (With Both Compressors Operating)

Entering Wet Bulb Temperature	Total Air Volume		Outdoor Temperature																							
			29°C (85°F)						35°C (95°F)						41°C (105°F)						46°C (115°F)					
			Total Cooling Capacity		Compressor Motor Input	Sensible To Total Ratio (S/T)			Total Cooling Capacity		Compressor Motor Input	Sensible To Total Ratio (S/T)			Total Cooling Capacity		Compressor Motor Input	Sensible To Total Ratio (S/T)			Total Cooling Capacity		Compressor Motor Input	Sensible To Total Ratio (S/T)		
						Dry Bulb						Dry Bulb						Dry Bulb						Dry Bulb		
m <sup>3</sup> /s	cfm	kW	Btuh	kW	24°C 76°F	27°C 80°F	29°C 84°F	kW	Btuh	kW	24°C 76°F	27°C 80°F	29°C 84°F	kW	Btuh	kW	24°C 76°F	27°C 80°F	29°C 84°F	kW	Btuh	kW	24°C 76°F	27°C 80°F	29°C 84°F	
17.2°C (63°F)	3.40	7200	62.6	213 500	18.41	.80	.93	1.00	59.4	202 700	19.61	.83	.96	1.00	56.0	191 000	20.71	.85	1.00	1.00	53.0	180 900	21.71	.88	1.00	1.00
	3.85	8200	63.7	217 400	18.57	.84	1.00	1.00	60.8	207 500	19.86	.87	1.00	1.00	57.8	197 100	21.02	.90	1.00	1.00	54.6	186 400	22.00	.93	1.00	1.00
	4.35	9200	64.9	221 300	18.73	.87	1.00	1.00	62.2	212 300	20.11	.92	1.00	1.00	59.6	203 200	21.33	.92	1.00	1.00	56.2	191 900	22.29	1.00	1.00	1.00
19.4°C (67°F)	3.40	7200	66.8	228 000	19.02	.62	.75	.87	63.2	215 500	20.22	.64	.77	.89	59.4	202 700	21.29	.65	.79	.93	55.6	189 700	22.16	.67	.82	.96
	3.85	8200	67.9	231 700	19.17	.65	.78	.91	64.5	220 000	20.37	.66	.80	.94	60.3	205 700	21.43	.68	.83	1.00	56.4	192 600	22.30	.70	.87	1.00
	4.35	9200	68.9	235 100	19.31	.67	.82	.96	65.0	221 900	20.50	.69	.85	1.00	61.1	208 400	21.56	.71	.88	1.00	57.1	194 900	22.44	.74	.91	1.00
21.7°C (71°F)	3.40	7200	71.7	244 600	19.69	.46	.57	.69	67.7	230 900	20.89	.46	.59	.71	63.6	216 900	21.94	.47	.60	.73	59.3	202 400	22.81	.48	.62	.76
	3.85	8200	72.7	248 200	19.83	.47	.60	.73	68.6	234 000	21.02	.48	.61	.75	64.4	219 600	22.06	.49	.63	.78	60.0	204 700	22.92	.50	.65	.81
	4.35	9200	73.6	251 300	19.94	.48	.62	.76	69.3	236 600	21.13	.49	.64	.79	65.0	221 800	22.16	.50	.66	.82	60.6	206 800	23.01	.51	.68	.85

### CHP11-2753 HEATING PERFORMANCE (With Both Compressors Operating) — 50 Hz

Indoor Coil Air Volume at 21°C (70°F)	*Outdoor Temperature															
	18°C (65°F)		7°C (45°F)		minus 4°C (25°F)		minus 15°C (5°F)		minus 26°C (minus 15°F)							
	Total Heating Capacity		Compressor Motor Input		Total Heating Capacity		Compressor Motor Input		Total Heating Capacity		Compressor Motor Input					
	kW	Btuh	kW	Btuh	kW	Btuh	kW	Btuh	kW	Btuh	kW	Btuh				
3.40	7200	82.1	280 400	18.83	58.4	199 400	16.08	41.8	142 600	13.58	30.2	103 000	11.39	21.1	72 000	9.25
3.85	8200	82.9	282 900	18.67	59.0	201 400	15.92	42.2	144 100	13.46	30.5	104 100	11.28	21.3	72 800	9.15
4.35	9200	83.7	285 500	18.50	59.6	203 400	15.75	42.6	145 400	13.33	30.8	105 100	11.17	21.5	73 400	9.06

\*At 70% relative humidity.

NOTE — Heating performance includes the effect of defrost cycles in the temperature range where they occur.

### INSTALLATION CLEARANCES — mm (inches)

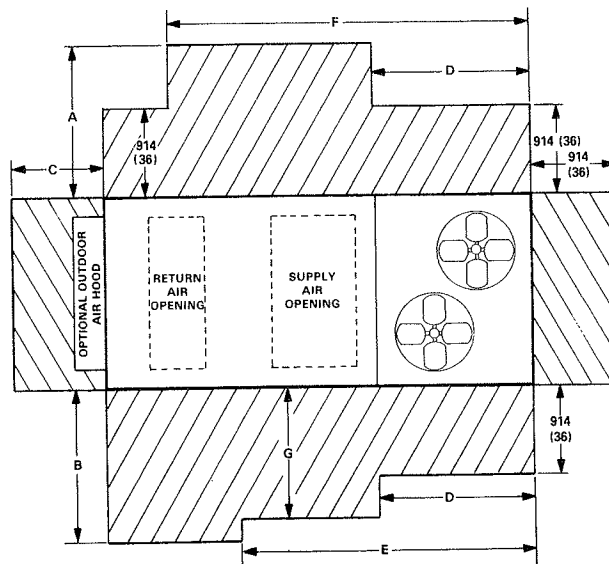

NOTE — Top Clearance Unobstructed.

Model Number	A	B	C	D	E	F	G
CHP11-953	mm	914	1168	610	1016	1626	914
	in.	36	46	24	40	64	36
CHP11-1353	mm	914	1626	813	1168	1778	914
	in.	36	64	32	46	70	36
CHP11-1853	mm	1118	1626	1118	1118	2032	*1219
	in.	44	64	44	44	80	*48
CHP11-2753	mm	1270	1880	1118	1575	2540	*1219
	in.	50	74	44	62	100	*48

# TYPICAL FLASHING DETAIL FOR RMF11 ROOF MOUNTING FRAME

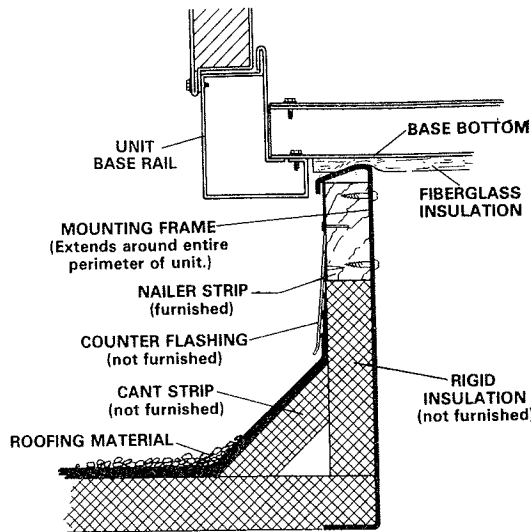

## DIMENSIONS — mm (inches) CHP11-953 AND CHP11-1353

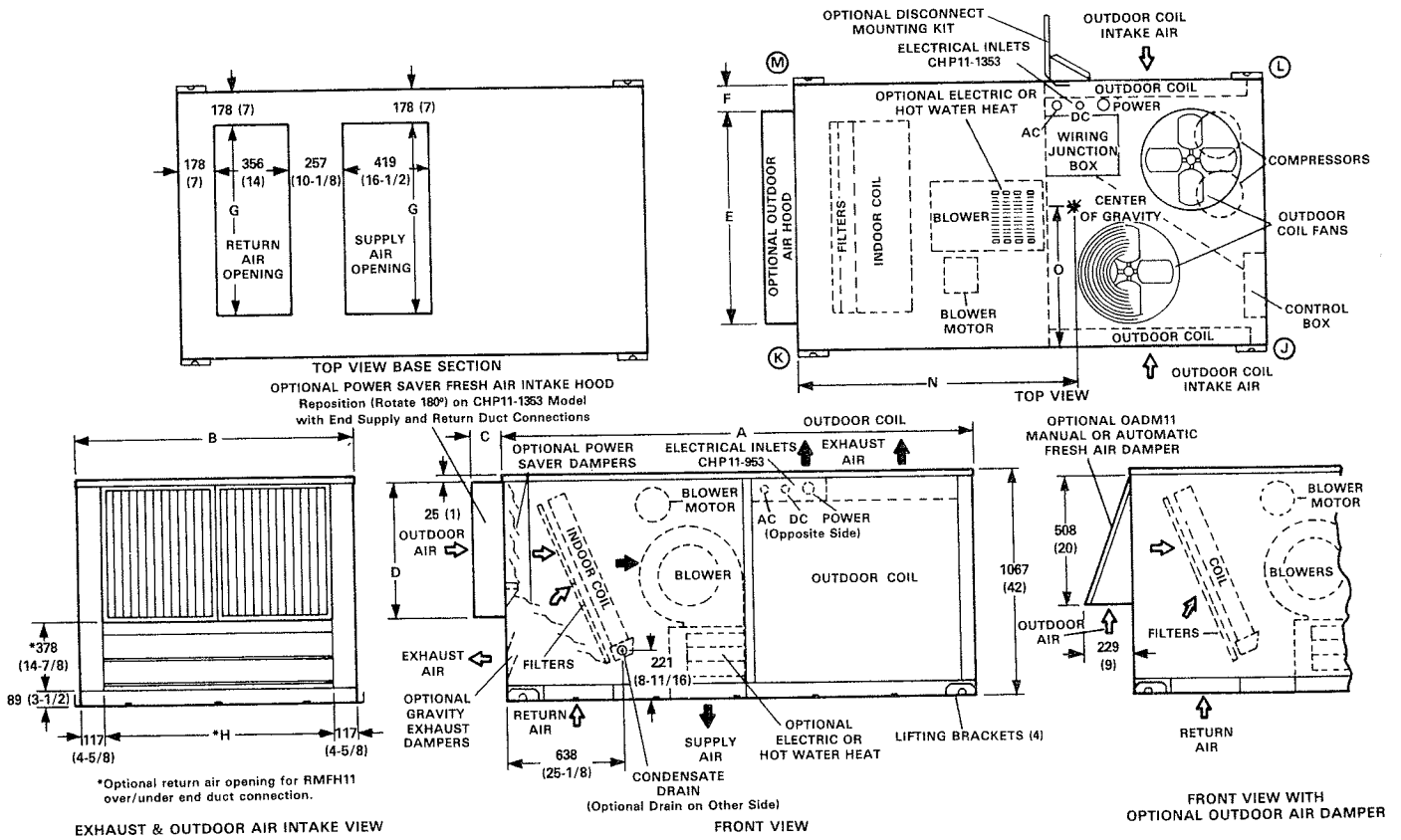

Model Number		A	B	C	D	E	F	G	H
CHP11-953	mm	2232	1270	156	527	1035	114	903	1035
	in.	87-7/8	50	6-1/8	20-3/4	40-3/4	4-1/2	35-9/16	40-3/4
CHP11-1353	mm	2372	1727	359	813	1600	60	1360	1492
	in.	93-3/8	68	14-1/8	32	63	2-3/8	53-9/16	58-3/4

### CORNER WEIGHTS

Model Number		J	K	L	M	
CHP11-953	With Power Saver	kg	152	140	159	146
		lbs.	335	309	350	321
	Without Power Saver	kg	151	116	158	121
		lbs.	334	256	348	267
CHP11-1353	With Power Saver	kg	190	205	195	211
		lbs.	419	451	431	465
	Without Power Saver	kg	190	164	195	169
		lbs.	419	362	431	373

### CENTER OF GRAVITY

Model Number		N	O	
CHP11-953	With Power Saver	mm	1162	648
		in.	45-3/4	25-1/2
	Without Power Saver	mm	1257	648
		in.	49-1/2	25-1/2
CHP11-1353	With Power Saver	mm	1143	876
		in.	45	34-1/2
	Without Power Saver	mm	1270	876
		in.	50	34-1/2

## DIMENSIONS – mm (inches) CHP11-1853 AND CHP11-2753

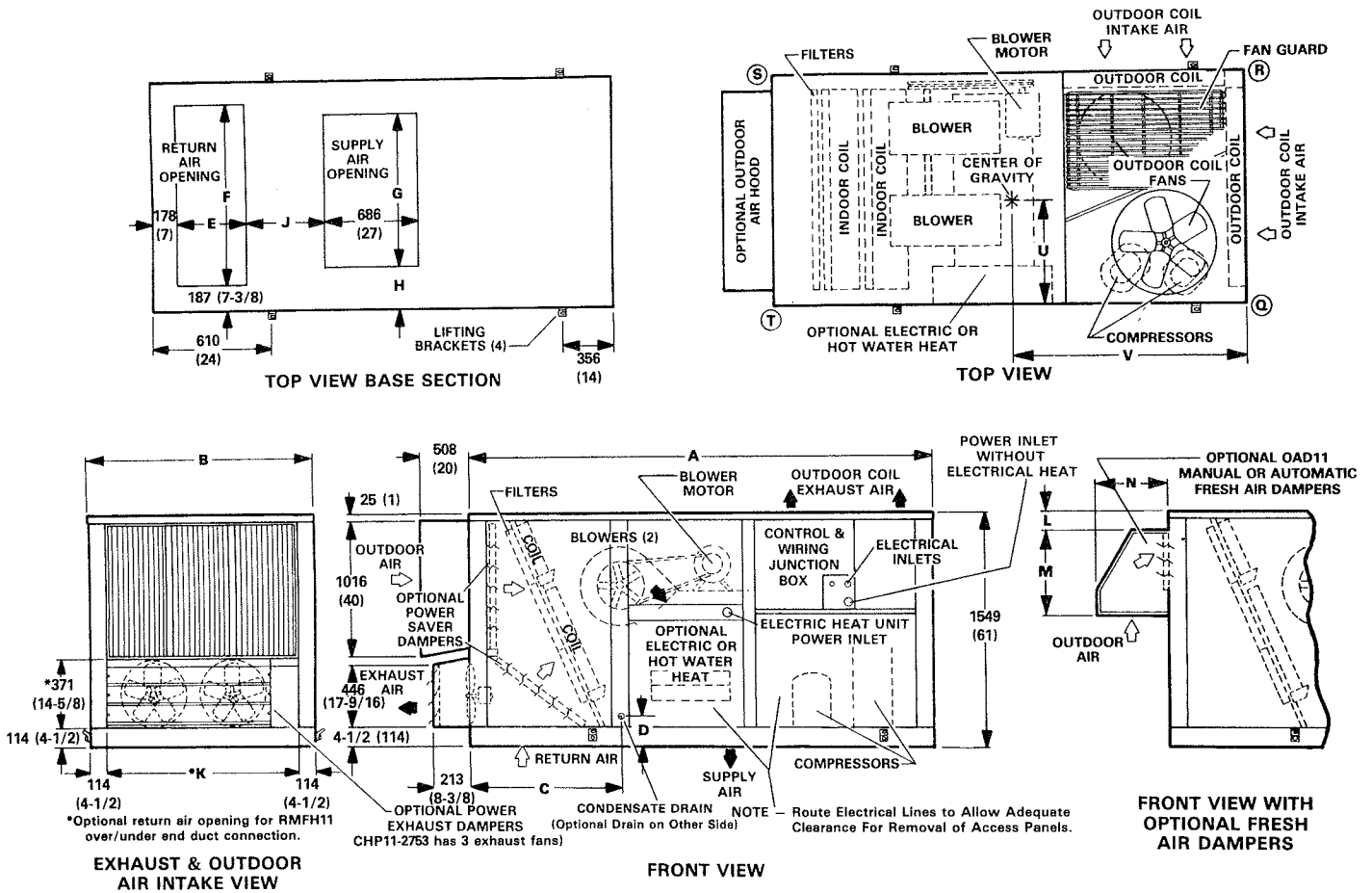

Model Number	A	B	C	D	E	F	G	H	J	K	L	M	N	
CHP11-1853	mm	2959	1727	835	211	457	1362	1194	267	489	1365	41	699	565
	in.	116-1/2	68	32-7/8	8-5/16	18	53-5/8	47	10-1/2	19-1/4	58-3/4	1-5/8	27-1/2	22-1/4
CHP11-2753	mm	3607	1981	1041	70	572	1616	1346	318	527	1746	187	845	616
	in.	142	78	41	2-3/4	22-1/2	63-5/8	53	12-1/2	20-3/4	68-3/4	7-3/8	33-1/4	24-1/4

### CORNER WEIGHTS

Model Number			Q	R	S	T
CHP11-1853	Basic Unit	kg	303	261	222	257
		lbs.	668	576	489	567
	With Power Saver	kg	337	274	241	297
		lbs.	744	605	532	654
With Power Saver/Exhaust Fans	kg	347	282	256	315	
	lbs.	764	621	565	695	
CHP11-2753	Basic Unit	kg	357	331	302	326
		lbs.	787	729	665	719
	With Power Saver	kg	397	349	328	372
		lbs.	875	770	723	821
With Power Saver/Exhaust Fans	kg	410	361	348	396	
	lbs.	904	795	768	873	

### CENTER OF GRAVITY

Model Number			U	V
CHP11-1853	Basic Unit	mm	800	1359
		in.	31-1/2	53-1/2
	With Power Saver	mm	775	1384
		in.	30-1/2	54-1/2
With Power Saver/Exhaust Fans	mm	775	1410	
	in.	30-1/2	55-1/2	
CHP11-2753	Basic Unit	mm	953	1721
		in.	37-1/2	67-3/4
	With Power Saver	mm	927	1746
		in.	36-1/2	68-3/4
With Power Saver/Exhaust Fans	mm	927	1772	
	in.	36-1/2	69-3/4	

## ROOF MOUNTING FRAME SPECIFICATIONS

Roof Mounting Frame is rigid enough to be spanned over its entire length or cantilevered if supported on either side of the center of gravity.

Model Number		CHP11-953		CHP11-1353		CHP11-853		CHP11-2753	
		RMF11	RMFH11	RMF11	RMFH11	RMF11	RMFH11	RMF11	RMFH11
*Frame moment of inertia (I)	mm <sup>4</sup>	2.83 x 10 <sup>7</sup>	10.49 x 10 <sup>7</sup>	2.83 x 10 <sup>7</sup>	10.49 x 10 <sup>7</sup>	2.83 x 10 <sup>7</sup>	21.52 x 10 <sup>7</sup>	2.83 x 10 <sup>7</sup>	21.52 x 10 <sup>7</sup>
	in. <sup>4</sup>	68	252	68	252	68	517	68	517
*Frame section modulus I/C	mm <sup>3</sup>	1.64 x 10 <sup>5</sup>	3.61 x 10 <sup>5</sup>	1.64 x 10 <sup>5</sup>	3.61 x 10 <sup>5</sup>	1.64 x 10 <sup>5</sup>	6.03 x 10 <sup>5</sup>	1.64 x 10 <sup>5</sup>	6.03 x 10 <sup>5</sup>
	in. <sup>3</sup>	10.0	22.0	10.0	22.0	10.0	36.8	10.0	36.8
Mounting frame weight	kg/m	9.4	13.1	9.4	14.9	14.6	20.1	14.6	20.1
	lb./ft.	6.3	8.8	6.3	10.0	9.8	13.5	9.8	13.5
Mounting frame design strength	MPa	138	138	138	138	138	138	138	138
	psi	20 000	20 000	20 000	20 000	20 000	20 000	20 000	20 000

\*Includes both sides of frame.

**DIMENSIONS — mm (inches)**

**RMF11 ROOF MOUNTING FRAME WITH DOUBLE DUCT OPENING**

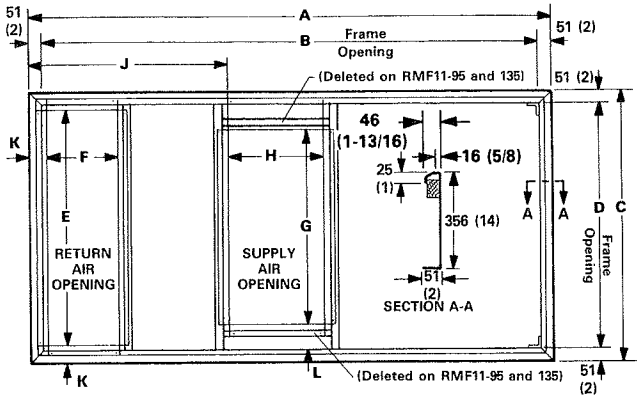

**PLENUM SUPPORT ANGLE DETAIL**

NOTE — Plenum support angles (furnished) must be field installed around perimeter of both supply and return air openings.

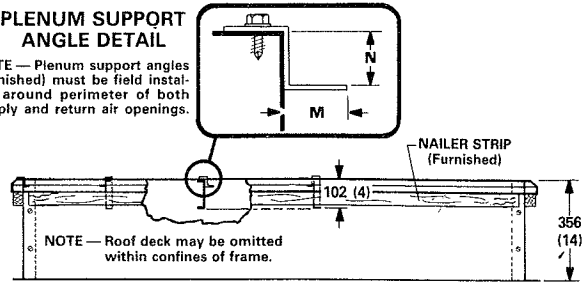

Model Number		A	B	C	D	E	F	G	H	J	K	L	M	N
RMF11-95	mm	2022	1921	1057	956	911	364	911	427	684	73	---	19	22
	in.	79-5/8	75-5/8	41-5/8	37-5/8	35-7/8	14-5/16	35-7/8	16-13/16	26-15/16	2-7/8	---	3/4	7/8
RMF11-135	mm	2162	2061	1514	1413	1368	364	1368	427	684	73	---	19	22
	in.	85-1/8	81-1/8	59-5/8	55-5/8	53-7/8	14-5/16	53-7/8	16-13/16	26-15/16	2-7/8	---	3/4	7/8
RMF11-185	mm	2746	2645	1514	1413	1378	473	1210	702	1030	68	102	16	17
	in.	108-1/8	104-1/8	59-5/8	55-5/8	54-1/4	18-5/8	47-5/8	27-5/8	40-9/16	2-11/16	4	5/8	11/16
RMF11-275	mm	3396	3294	1768	1667	1632	587	1362	702	1167	68	152	16	17
	in.	133-11/16	129-11/16	69-5/8	65-5/8	64-1/4	23-1/8	53-5/8	27-5/8	45-15/16	2-11/16	6	5/8	11/16

**RMF11-95 ROOF MOUNTING FRAME WITH SUPPLY AND RETURN TRANSITIONS FOR FD11-95 AND RTD11-95 DIFFUSERS**

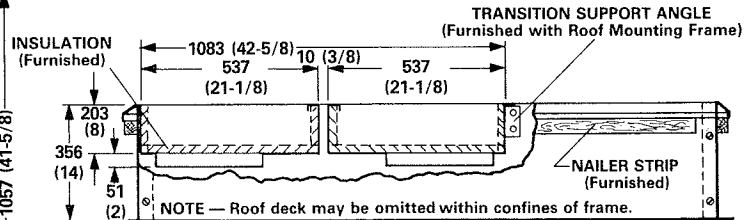
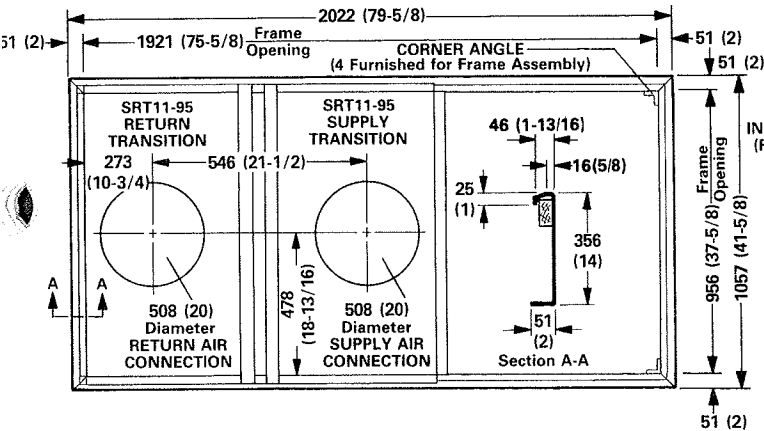

**RMF11-135, 185 AND 275 ROOF MOUNTING FRAME WITH SUPPLY AND RETURN TRANSITIONS FOR FD11 AND RTD11-135, 185 AND 275 DIFFUSERS**

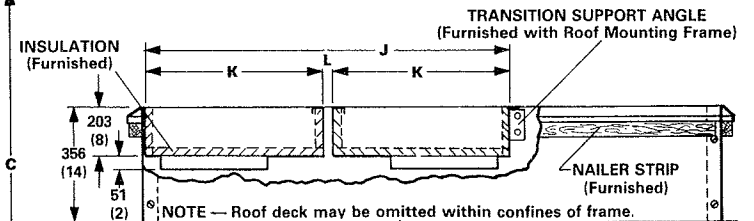
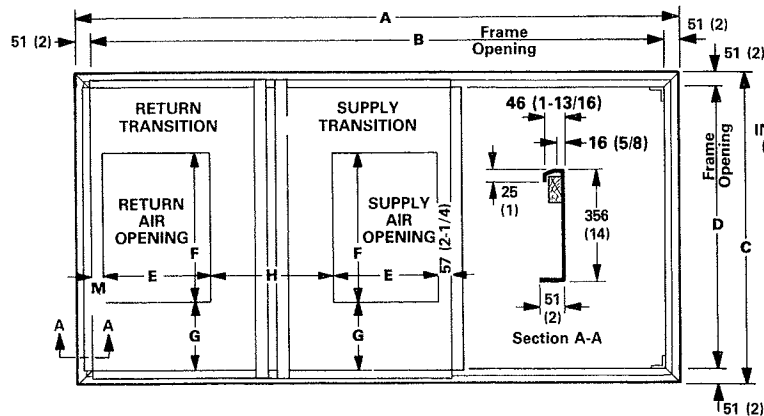

Model Number		A	B	C	D	E	F	G	H	J	K	L	M
RMF11-135	mm	2162	2061	1514	1413	457	711	351	117	1083	537	10	25
	in.	85-1/8	81-1/8	59-5/8	55-5/8	18	28	13-13/16	4-5/8	42-5/8	21-1/8	3/8	1
RMF11-185	mm	2746	2645	1514	1413	457	914	249	654	1683	835	13	57
	in.	108-1/8	104-1/8	59-5/8	55-5/8	18	36	9-13/16	25-3/4	66-1/4	32-7/8	1/2	2-1/4
RMF11-275	mm	3396	3294	1768	1667	610	1219	224	502	1835	911	13	57
	in.	133-11/16	129-11/16	69-5/8	65-5/8	24	48	8-13/16	19-3/4	72-1/4	35-7/8	1/2	2-1/4

**DIMENSIONS – mm (inches)**

**RMFH11 HORIZONTAL MOUNTING FRAME**

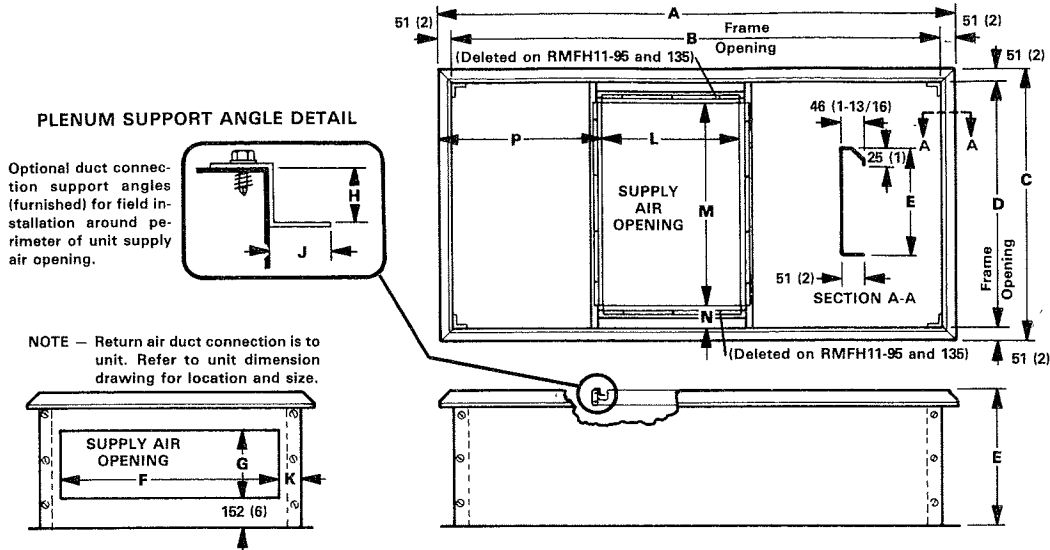

Model Number		A	B	C	D	E	F	G	H	J	K	L	M	N	P
RMFH11-95	mm	2022	1921	1057	956	584	787	305	19	22	97	427	911	----	684
	in.	79-5/8	75-5/8	41-5/8	37-5/8	23	31	12	3/4	7/8	3-13/16	16-13/16	35-7/8	----	26-15/16
RMFH11-135	mm	2162	2061	1514	1413	584	1219	305	19	22	97	427	1368	----	684
	in.	85-1/8	81-1/8	59-5/8	55-5/8	23	48	12	3/4	7/8	3-13/16	16-13/16	53-7/8	----	26-15/16
RMFH11-185	mm	2746	2645	1514	1413	762	1219	432	16	17	97	702	1210	102	1030
	in.	108-1/8	104-1/8	59-5/8	55-5/8	30	48	17	5/8	11/16	3-13/16	27-5/8	47-5/8	4	40-9/16
RMFH11-275	mm	3396	3294	1768	1667	762	1473	432	16	17	97	702	1362	152	1167
	in.	133-11/16	129-11/16	69-5/8	65-5/8	30	58	17	5/8	11/16	3-13/16	27-5/8	53-5/8	6	45-15/16

**TYPICAL FLASHING DETAIL FOR RMFA11 AND RMF3 ROOF MOUNTING FRAME**

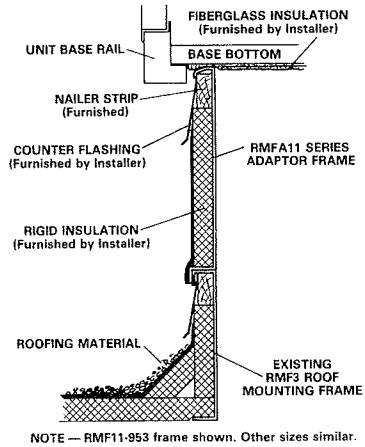

NOTE — RMF11-953 frame shown. Other sizes similar.

**RMFA11 ROOF MOUNTING FRAME WITH RMF3 ROOF MOUNTING FRAME**

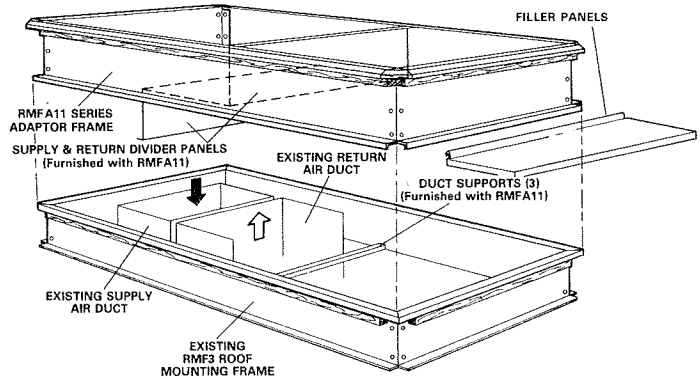

**RMFA11 ADAPTER MOUNTING FRAME**

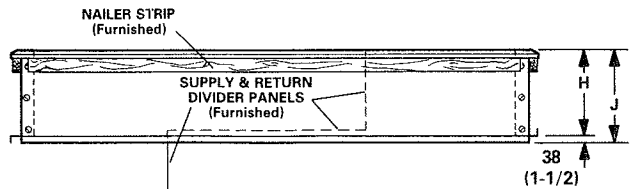
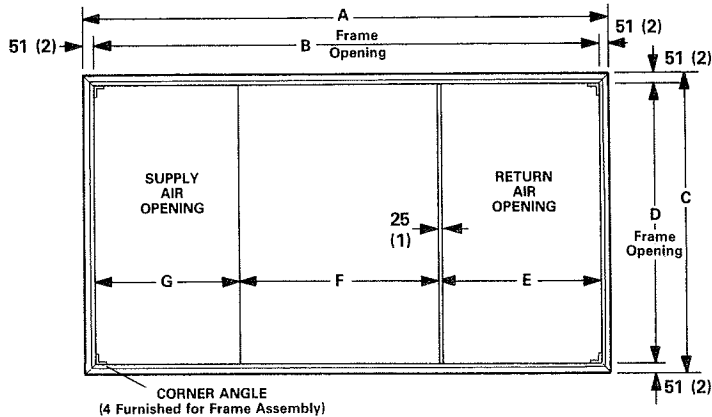

Model Number		A	B	C	D	E	F	G	H	J
RMFA11-95	mm	2022	1921	1057	956	591	594	584	445	483
	in.	79-5/8	75-5/8	41-5/8	37-5/8	23-1/4	28-3/8	23	17-1/2	19
RMFA11-135	mm	2162	2061	1514	1413	435	841	759	445	483
	in.	85-1/8	81-1/8	59-5/8	55-5/8	17-1/8	33-1/8	29-7/8	17-1/2	19



## AIR PATTERN

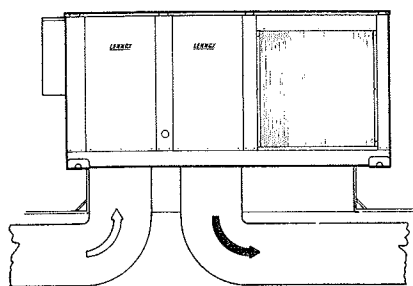

Separate Supply and Return (Double) Duct

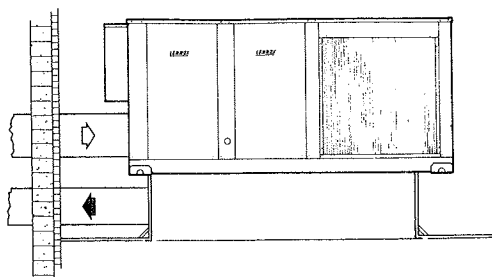

End Supply and Return Air  
(over and under) Duct Application

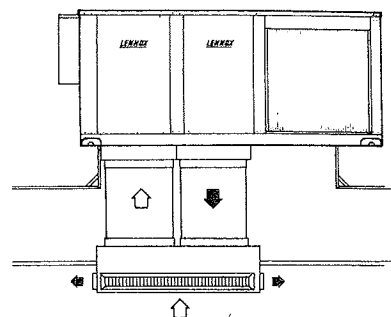

Combination Supply and Return Air Ceiling Diffuser  
Step-down or Flush Grille

## COMBINATION CEILING SUPPLY AND RETURN AIR DIFFUSERS

### STEP-DOWN CEILING DIFFUSER (RTD11-95 Model Shown)

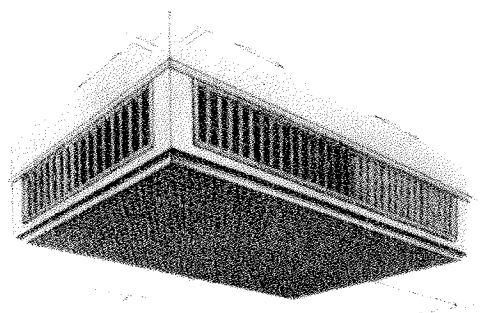

### FLUSH CEILING DIFFUSER (FD11-95 Model Shown)

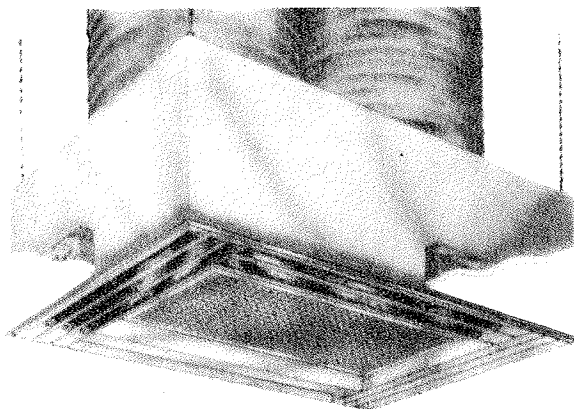

**Optional RTD11 Combination Ceiling Supply and Return Diffuser Assembly** — Step-down mount diffuser extends slightly below ceiling level and discharges conditioned air out through grilles on all four sides. Aluminum grilles are fitted with double deflection louvers for precise directional control of air flow. Return air enters through the large center grille. Assembly also includes insulated diffuser box with flanges for ease of duct connection, hanging rings for suspending and interior transition to insure low static and even air flow on all four sides. Transition is sealed internally to prevent recirculation. Diffuser assembly is completely factory assembled. Diffuser readily adapts to T-bar ceiling grids and plaster ceilings. RTD11-95 model diffuser is used with the CHP11-953 unit, RTD11-135 with the CHP11-1353, RTD11-185 with the CHP11-1853 and RTD11-275 with the CHP11-2753.

**Optional FD11 Combination Ceiling Supply and Return Diffuser Assembly** — Flush mount diffuser installs almost flush with the ceiling level and discharges conditioned air out through fixed blade louvers on all four sides. Fixed blade louvers insure that air flow will be evenly distributed. Return air enters through large center grille. Assembly also includes insulated diffuser box with flanges for ease of duct connections, support hanger eyelets at the top corners for secure installation and interior transition to insure low static and even air flow on all four sides. Transition is sealed internally to prevent recirculation. Diffuser assembly is completely factory assembled. Diffuser readily adapts to T-bar ceiling grids and plaster ceilings. FD11-95 model diffuser is used with the CHP11-953 unit, FD11-135 with the CHP11-1353, FD11-185 with the CHP11-1853 and FD11-275 with the CHP11-2753.

**Optional Supply and Return Transitions** — Transitions field install in the roof mounting frame and provide segregated and simple duct connections to supply and return diffuser. Completely insulated galvanized steel transitions have flanges for ease of duct connection. Duct from the transitions to the diffuser is not furnished and must be provided by installer. Transitions are completely factory assembled and easily field installed in the roof mounting frame with the minimum costs and labor requirements. SRT11-95 transitions are used with the RMF11-95 roof mounting frame, SRT11-135 with the RMF11-135 frame, SRT11-185 with the RMF11-185 frame and SRT11-275 with the RMF11-275 frame.

**DIMENSIONS – mm (inches)**

**RTD11-95 STEP-DOWN CEILING DIFFUSER**

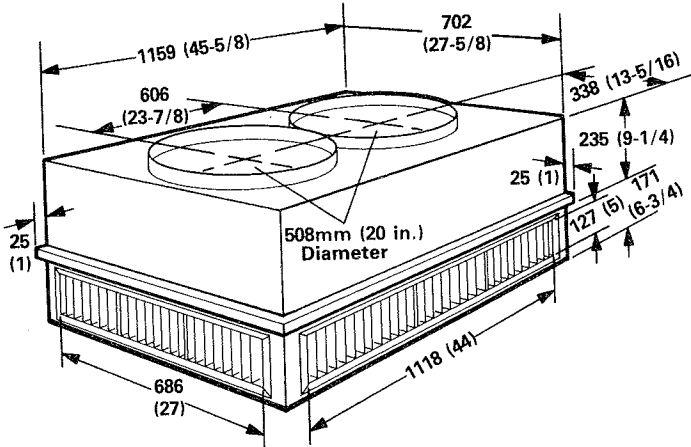

0.457m<sup>2</sup> (4.925 sq. ft.) Free Supply Area Provided  
0.733m<sup>2</sup> (7.89 sq. ft.) Free Return Area Provided

**FD11-95 FLUSH CEILING DIFFUSER**

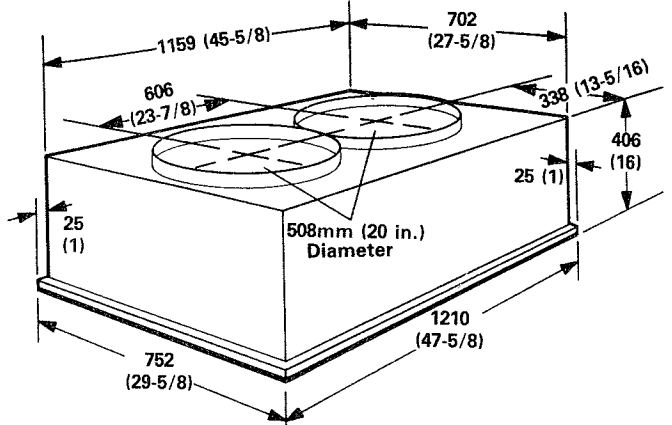

0.319m<sup>2</sup> (3.44 sq. ft.) Free Supply Area Provided  
0.323m<sup>2</sup> (3.48 sq. ft.) Free Return Area Provided

**RTD11-135, RTD11-185 AND RTD11-275 STEP-DOWN CEILING DIFFUSER**

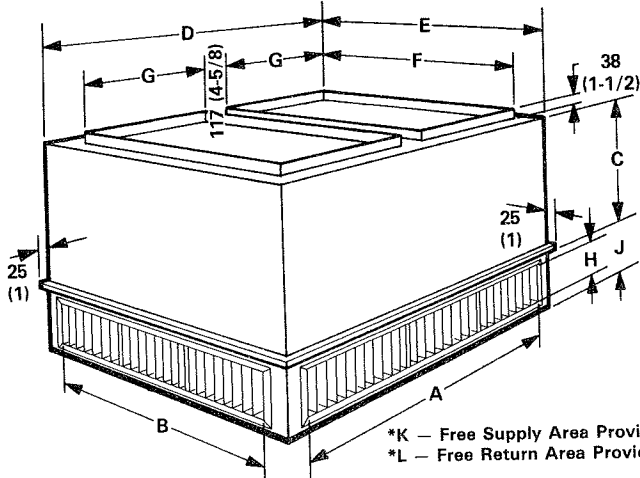

\*K – Free Supply Area Provided m<sup>2</sup> (sq. ft.)  
\*L – Free Return Area Provided m<sup>2</sup> (sq. ft.)

**FD11-135, FD11-185 AND FD11-275 FLUSH CEILING DIFFUSER**

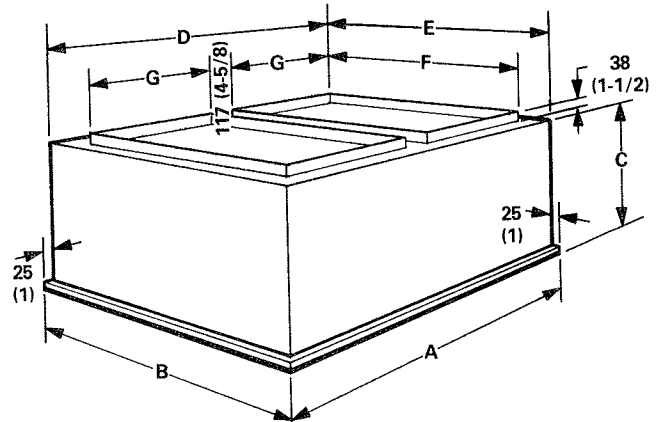

\*H – Free Supply Area Provided m<sup>2</sup> (sq. ft.)  
\*J – Free Return Area Provided m<sup>2</sup> (sq. ft.)

Model Number	A	B	C	D	E	F	G	H	J	*K	*L	
RTD11-135	in.	44	32	20-5/8	45-5/8	33-5/8	28	18	5	6-3/4	5.27	9.78
	mm	1118	813	524	1159	854	711	457	127	171	0.490	0.909
RTD11-185	in.	44	44	26-1/8	45-5/8	45-5/8	36	18	6	7-3/4	6.01	12.35
	mm	1118	1118	664	1159	1159	914	457	152	197	0.558	1.147
RTD11-275	in.	55	55	31-1/2	57-5/8	57-5/8	48	24	7	8-7/8	8.77	19.04
	mm	1397	1397	800	1464	1464	1219	610	178	225	0.815	1.769

Model Number	A	B	C	D	E	F	G	*H	*J	
FD11-135	in.	47-5/8	35-5/8	24	45-5/8	33-5/8	28	18	3.73	4.57
	mm	1210	905	610	1159	854	711	457	0.347	0.425
FD11-185	in.	47-5/8	47-5/8	30	45-5/8	45-5/8	36	18	4.35	6.63
	mm	1210	1210	762	1159	1159	914	457	0.404	0.616
FD11-275	in.	59-5/8	59-5/8	36	57-5/8	57-5/8	48	24	5.45	12.57
	mm	1514	1514	914	1464	1464	1219	610	0.506	0.168

**DIFFUSER AIR PATTERN**

**FLUSH DIFFUSER (FD11-95 Model Shown)**

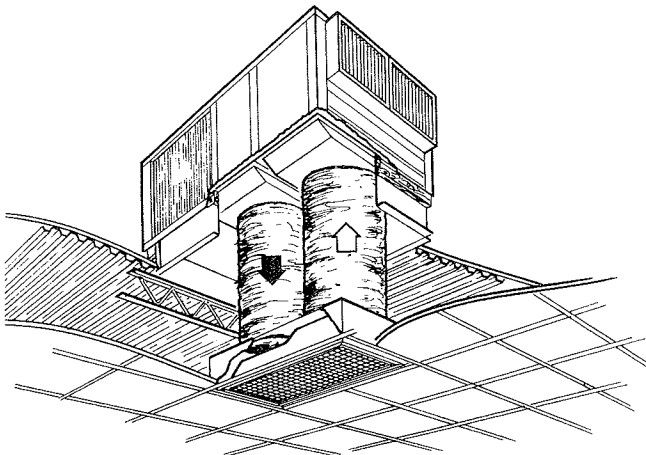

**FLUSH DIFFUSER (FD11-135 Model Shown)**

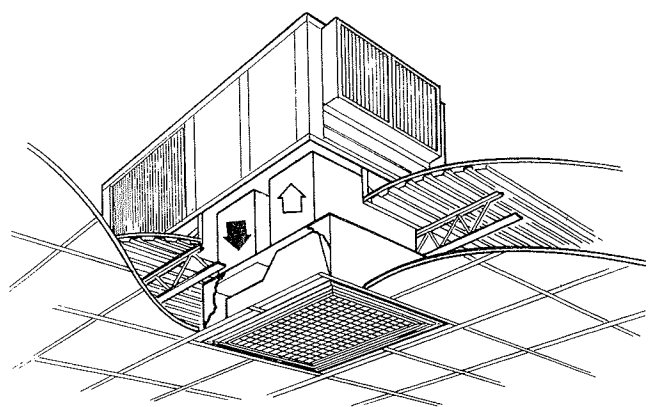

## BLOWER DATA

### CHP11-953 BLOWER PERFORMANCE

Air Volume m <sup>3</sup> /s (cfm)	STATIC PRESSURE EXTERNAL TO UNIT — Pa (Inches Water Gauge)										
	50 (.20)	75 (.30)	100 (.40)	125 (.50)	150 (.60)	175 (.70)	200 (.80)	225 (.90)	250 (1.0)	325 (1.30)	375 (1.50)
	Rev/ kW min. (hp)	Rev/ kW min. (hp)	Rev/ kW min. (hp)	Rev/ kW min. (hp)	Rev/ kW min. (hp)	Rev/ kW min. (hp)	Rev/ kW min. (hp)	Rev/ kW min. (hp)	Rev/ kW min. (hp)	Rev/ kW min. (hp)	Rev/ kW min. (hp)
1.25 (2600)	.67 670 (.90)	.78 700 (1.05)	.90 730 (1.20)	1.01 770 (1.35)	1.08 800 (1.45)	1.19 830 (1.60)	1.27 855 (1.70)	1.38 890 (1.85)	1.45 915 (1.95)	1.79 990 (2.40)	2.09 1045 (2.80)
1.30 (2800)	.82 705 (1.10)	.93 735 (1.25)	1.04 775 (1.40)	1.16 810 (1.55)	1.27 835 (1.70)	1.34 860 (1.80)	1.45 895 (1.95)	1.57 920 (2.10)	1.64 945 (2.20)	2.01 1015 (2.70)	2.31 1065 (3.10)
1.40 (3000)	1.01 740 (1.35)	1.12 775 (1.50)	1.23 810 (1.65)	1.34 840 (1.80)	1.45 870 (1.95)	1.57 905 (2.10)	1.72 930 (2.30)	1.79 950 (2.40)	1.90 975 (2.55)	2.28 1040 (3.05)	2.54 1080 (3.40)
1.50 (3200)	1.19 780 (1.60)	1.31 820 (1.75)	1.38 845 (1.85)	1.49 875 (2.00)	1.64 910 (2.20)	1.79 935 (2.40)	1.90 960 (2.55)	2.01 985 (2.70)	2.16 1010 (2.90)	2.54 1070 (3.40)	----
1.60 (3400)	1.38 825 (1.85)	1.53 855 (2.05)	1.64 885 (2.20)	1.75 920 (2.35)	1.90 945 (2.55)	2.05 970 (2.75)	2.16 995 (2.90)	2.31 1020 (3.10)	2.42 1050 (3.25)	----	----
1.70 (3600)	1.60 860 (2.15)	1.72 895 (2.30)	1.87 925 (2.50)	2.01 950 (2.70)	2.16 975 (2.90)	2.42 1010 (3.25)	2.42 1020 (3.25)	2.54 1050 (3.40)	----	----	----

NOTE — Data is measured external to the unit cabinet with the air filter in place. See Page 70 for Accessory Air Resistance data.  
 Legend — Rev/min. = Blower speed required. kW (hp) = Motor output required.

### CHP11-1353 BLOWER PERFORMANCE

Air Volume m <sup>3</sup> /s (cfm)	STATIC PRESSURE EXTERNAL TO UNIT — Pa (Inches Water Gauge)										
	50 (.20)	75 (.30)	100 (.40)	125 (.50)	150 (.60)	175 (.70)	200 (.80)	225 (.90)	250 (1.0)	325 (1.30)	375 (1.50)
	Rev/ kW min. (hp)	Rev/ kW min. (hp)	Rev/ kW min. (hp)	Rev/ kW min. (hp)	Rev/ kW min. (hp)	Rev/ kW min. (hp)	Rev/ kW min. (hp)	Rev/ kW min. (hp)	Rev/ kW min. (hp)	Rev/ kW min. (hp)	Rev/ kW min. (hp)
1.65 (3500)	.56 550 (.75)	.67 595 (.90)	.82 630 (1.10)	.93 665 (1.25)	1.01 700 (1.35)	1.04 730 (1.40)	1.12 760 (1.50)	1.23 790 (1.65)	1.31 820 (1.75)	1.49 895 (2.00)	1.72 945 (2.30)
1.70 (3600)	.63 560 (.85)	.75 605 (1.00)	.86 640 (1.15)	1.01 670 (1.35)	1.04 710 (1.40)	1.12 735 (1.50)	1.23 770 (1.65)	1.31 800 (1.75)	1.38 825 (1.85)	1.72 910 (2.30)	1.94 960 (2.60)
1.80 (3800)	.71 575 (.95)	.86 625 (1.15)	.97 655 (1.30)	1.04 685 (1.40)	1.16 720 (1.55)	1.27 755 (1.70)	1.38 780 (1.85)	1.45 810 (1.95)	1.57 840 (2.10)	1.94 925 (2.60)	2.16 975 (2.90)
1.90 (4000)	.86 605 (1.15)	1.01 640 (1.35)	1.08 665 (1.45)	1.16 705 (1.55)	1.27 730 (1.70)	1.38 770 (1.85)	1.49 800 (2.00)	1.60 825 (2.15)	1.72 855 (2.30)	2.13 940 (2.85)	2.39 990 (3.20)
2.00 (4200)	.97 625 (1.30)	1.08 660 (1.45)	1.23 685 (1.65)	1.27 720 (1.70)	1.42 750 (1.90)	1.53 780 (2.05)	1.64 815 (2.20)	1.76 840 (2.35)	1.87 870 (2.50)	2.35 960 (3.15)	2.54 1010 (3.40)
2.1 (4400)	1.12 645 (1.50)	1.23 670 (1.65)	1.31 700 (1.75)	1.42 735 (1.90)	1.57 770 (2.10)	1.72 800 (2.30)	1.79 825 (2.40)	1.94 860 (2.60)	2.09 885 (2.80)	2.54 975 (3.40)	2.76 1025 (3.70)
2.15 (4600)	1.27 670 (1.70)	1.34 685 (1.80)	1.45 720 (1.95)	1.60 755 (2.15)	1.72 780 (2.30)	1.83 815 (2.45)	1.98 840 (2.65)	2.13 875 (2.85)	2.28 905 (3.05)	2.72 990 (3.65)	2.98 1040 (4.00)
2.25 (4800)	1.34 680 (1.80)	1.45 705 (1.95)	1.60 740 (2.15)	1.75 770 (2.35)	1.90 805 (2.55)	2.05 830 (2.75)	2.20 865 (2.95)	2.35 890 (3.15)	2.42 920 (3.25)	2.91 1005 (3.90)	3.13 1055 (4.20)

NOTE — Data is measured external to the unit cabinet with the air filter in place. See Page 70 for Accessory Air Resistance data.  
 Legend — Rev/min. = Blower speed required. kW (hp) = Motor output required.

## BLOWER DATA

### CHP11-1853 BLOWER PERFORMANCE

Air Volume m <sup>3</sup> /s (cfm)	STATIC PRESSURE EXTERNAL TO UNIT — Pa (Inches Water Gauge)																					
	50 (.20)		75 (.30)		100 (.40)		125 (.50)		150 (.60)		175 (.70)		200 (.80)		225 (.90)		250 (1.0)		325 (1.30)		375 (1.50)	
	Rev/ min.	kW (hp)	Rev/ min.	kW (hp)	Rev/ min.	kW (hp)	Rev/ min.	kW (hp)	Rev/ min.	kW (hp)	Rev/ min.	kW (hp)	Rev/ min.	kW (hp)	Rev/ min.	kW (hp)	Rev/ min.	kW (hp)	Rev/ min.	kW (hp)	Rev/ min.	kW (hp)
2.45 (5200)	580	1.12 (1.50)	625	1.30 (1.75)	665	1.45 (1.95)	700	1.64 (2.20)	730	1.78 (2.38)	760	1.90 (2.55)	785	2.05 (2.75)	815	2.16 (2.90)	845	2.35 (3.15)	930	2.83 (3.80)	1000	3.43 (4.60)
2.55 (5400)	590	1.19 (1.60)	640	1.42 (1.90)	675	1.60 (2.15)	715	1.75 (2.35)	740	1.86 (2.50)	770	2.00 (2.70)	800	2.16 (2.90)	825	2.31 (3.10)	855	2.54 (3.40)	940	3.10 (4.15)	1010	3.50 (4.70)
2.65 (5600)	605	1.30 (1.75)	650	1.50 (2.00)	685	1.70 (2.30)	725	1.86 (2.50)	750	2.05 (2.75)	785	2.16 (2.90)	810	2.31 (3.10)	840	2.50 (3.35)	865	2.68 (3.60)	950	3.28 (4.40)	1020	3.65 (4.90)
2.75 (5800)	620	1.45 (1.95)	660	1.60 (2.15)	695	1.83 (2.45)	730	1.94 (2.60)	760	2.13 (2.85)	795	2.31 (3.10)	820	2.46 (3.30)	850	2.65 (3.55)	875	2.83 (3.80)	965	3.47 (4.65)	1035	3.80 (5.10)
2.85 (6000)	635	1.57 (2.10)	675	1.75 (2.35)	710	1.98 (2.65)	745	2.09 (2.80)	775	2.28 (3.05)	805	2.46 (3.30)	835	2.65 (3.55)	865	2.83 (3.80)	890	3.02 (4.05)	975	3.66 (4.90)	1045	4.03 (5.40)
2.95 (6200)	650	1.72 (2.30)	690	1.90 (2.55)	725	2.13 (2.85)	760	2.24 (3.00)	790	2.46 (3.30)	815	2.65 (3.55)	850	2.83 (3.80)	875	3.02 (4.05)	900	3.21 (4.30)	990	3.84 (5.15)	1060	4.25 (5.70)
3.00 (6400)	665	1.87 (2.50)	705	2.05 (2.75)	735	2.28 (3.05)	770	2.42 (3.25)	800	2.61 (3.50)	830	2.80 (3.75)	860	3.02 (4.05)	890	3.21 (4.30)	915	3.39 (4.55)	1000	4.03 (5.40)	----	----
3.10 (6600)	680	1.98 (2.65)	720	2.16 (2.90)	750	2.39 (3.20)	785	2.57 (3.45)	815	2.80 (3.75)	840	2.98 (4.00)	875	3.21 (4.30)	900	3.39 (4.55)	925	3.58 (4.80)	1015	4.21 (5.65)	----	----
3.20 (6800)	695	2.09 (2.80)	730	2.31 (3.10)	760	2.54 (3.40)	800	2.76 (3.70)	830	2.98 (4.00)	855	3.13 (4.20)	885	3.39 (4.55)	915	3.58 (4.80)	940	3.77 (5.05)	----	----	----	----
3.30 (7000)	710	2.24 (3.00)	745	2.46 (3.30)	775	2.69 (3.60)	810	2.91 (3.90)	840	3.13 (4.20)	865	3.32 (4.45)	900	3.58 (4.80)	925	3.77 (5.05)	950	3.95 (5.30)	----	----	----	----
3.40 (7200)	720	2.42 (3.25)	760	2.61 (3.50)	790	2.87 (3.85)	820	3.10 (4.15)	850	3.32 (4.45)	880	3.54 (4.75)	910	3.77 (5.05)	935	3.95 (5.30)	960	4.17 (5.60)	----	----	----	----

NOTE — Data is measured external to the unit cabinet with the air filter in place. See Page 70 for Accessory Air Resistance data.  
 Legend — Rev/min. = Blower speed required. kW (hp) = Motor output required.

### CHP11-2753 BLOWER PERFORMANCE

Air Volume m <sup>3</sup> /s (cfm)	STATIC PRESSURE EXTERNAL TO UNIT — Pa (Inches Water Gauge)																					
	50 (.20)		75 (.30)		100 (.40)		125 (.50)		150 (.60)		175 (.70)		200 (.80)		225 (.90)		250 (1.0)		325 (1.30)		375 (1.50)	
	Rev/ min.	kW (hp)	Rev/ min.	kW (hp)	Rev/ min.	kW (hp)	Rev/ min.	kW (hp)	Rev/ min.	kW (hp)	Rev/ min.	kW (hp)	Rev/ min.	kW (hp)	Rev/ min.	kW (hp)	Rev/ min.	kW (hp)	Rev/ min.	kW (hp)	Rev/ min.	kW (hp)
3.30 (7000)	575	1.38 (1.85)	610	1.64 (2.20)	640	1.79 (2.40)	680	2.09 (2.80)	720	2.31 (3.10)	760	2.54 (3.40)	800	2.80 (3.75)	830	2.87 (3.85)	870	3.21 (4.30)	960	3.88 (5.20)	1015	4.44 (5.95)
3.40 (7200)	580	1.50 (2.00)	620	1.75 (2.35)	655	1.98 (2.65)	690	2.20 (2.95)	730	2.39 (3.20)	770	2.65 (3.55)	810	2.83 (3.80)	840	2.98 (4.00)	875	3.28 (4.40)	965	4.00 (5.35)	1020	4.60 (6.15)
3.50 (7400)	590	1.64 (2.20)	630	1.86 (2.50)	670	2.10 (2.80)	700	2.31 (3.10)	740	2.54 (3.40)	780	2.75 (3.70)	815	2.95 (3.95)	845	3.10 (4.15)	880	3.35 (4.50)	970	4.10 (5.50)	1025	4.65 (6.25)
3.60 (7600)	595	1.75 (2.35)	640	1.94 (2.60)	680	2.20 (2.95)	715	2.42 (3.25)	750	2.65 (3.55)	785	2.83 (3.80)	820	3.06 (4.10)	855	3.25 (4.35)	890	3.47 (4.65)	975	4.21 (5.65)	1030	4.81 (6.45)
3.70 (7800)	610	1.90 (2.55)	650	2.09 (2.80)	690	2.31 (3.10)	725	2.57 (3.45)	760	2.76 (3.70)	790	2.95 (3.95)	825	3.13 (4.20)	860	3.36 (4.50)	895	3.58 (4.80)	980	4.33 (5.80)	1035	4.96 (6.65)
3.80 (8000)	620	2.01 (2.70)	660	2.20 (2.95)	700	2.46 (3.30)	735	2.69 (3.60)	770	2.87 (3.85)	800	3.06 (4.10)	830	3.25 (4.35)	870	3.47 (4.65)	900	3.69 (4.95)	985	4.48 (6.00)	1040	5.07 (6.80)
3.85 (8200)	630	2.13 (2.85)	670	2.31 (3.10)	710	2.61 (3.50)	745	2.80 (3.75)	780	2.98 (4.00)	810	3.17 (4.25)	840	3.36 (4.50)	880	3.62 (4.85)	910	3.84 (5.15)	990	4.63 (6.20)	1045	5.22 (7.00)
3.95 (8400)	645	2.28 (3.05)	680	2.46 (3.30)	720	2.72 (3.65)	755	2.95 (3.95)	790	3.10 (4.15)	815	3.28 (4.40)	850	3.51 (4.70)	885	3.77 (5.05)	915	3.95 (5.30)	995	4.74 (6.35)	1050	5.33 (7.15)
4.05 (8600)	655	2.39 (3.20)	695	2.57 (3.45)	730	2.87 (3.85)	765	3.06 (4.10)	800	3.25 (4.35)	825	3.43 (4.60)	860	3.62 (4.85)	895	3.92 (5.25)	920	4.10 (5.50)	1000	4.89 (6.55)	1055	5.48 (7.35)
4.15 (8800)	670	2.54 (3.40)	705	2.72 (3.65)	740	2.98 (4.00)	775	3.21 (4.30)	805	3.36 (4.50)	830	3.54 (4.75)	865	3.77 (5.05)	900	4.03 (5.40)	930	4.21 (5.65)	1010	5.00 (6.70)	1060	5.60 (7.50)
4.25 (9000)	680	2.65 (3.55)	715	2.83 (3.80)	750	3.13 (4.20)	785	3.32 (4.45)	815	3.47 (4.65)	840	3.66 (4.90)	875	3.88 (5.20)	910	4.18 (5.60)	935	4.36 (5.85)	1015	5.15 (6.90)	1065	5.74 (7.70)
4.35 (9200)	690	2.80 (3.75)	725	3.02 (4.05)	760	3.28 (4.40)	795	3.47 (4.65)	825	3.62 (4.85)	850	3.84 (5.15)	885	4.07 (5.45)	920	4.33 (5.80)	945	4.51 (6.05)	1020	5.33 (7.15)	1070	5.93 (7.95)
4.45 (9400)	700	2.95 (3.95)	735	3.17 (4.25)	770	3.43 (4.60)	800	3.62 (4.85)	830	3.78 (5.05)	860	3.99 (5.35)	895	4.21 (5.65)	925	4.48 (6.00)	950	4.70 (6.30)	1030	5.52 (7.40)	1075	6.12 (8.20)

NOTE — Data is measured external to the unit cabinet with the air filter in place. See Page 70 for Accessory Air Resistance data.  
 Legend — Rev/min. = Blower speed required. kW (hp) = Motor output required.

# BLOWER DATA

## BLOWER DRIVE SELECTION

Using total air volume and system Static Pressure External to Unit requirements, determine from Blower Performance Chart rev/min and blower motor output required for job. Specify blower motor output, rev/min

and electrical characteristics required when ordering. The correct motor and pulleys will be factory installed. The following table lists blower motor output and blower speed range of drives available with each motor.

CHP11-953 AND CHP11-1353

Model Number	*Nominal Motor Output		Blower Speed (rev/min) at 1440 rev/min Motor Speed
	kW	hp	
CHP11-953	1.1	1.5	785 - 965
	2.2	3	785 - 965 895 - 1075 (Electric Heat)
CHP11-1353	2.2	3	750 - 905
	3.7	5	890 - 1070

\*Service Factor = 1.15

CHP11-1853 AND CHP11-2753

Model Number	*Nominal Motor Output		Blower Speed (rev/min) at 1440 rev/min Motor Speed
	kW	hp	
CHP11-1853	3.7	5	845 - 995
CHP11-2753	3.7	5	750 - 905
	5.6	7-1/2	890 - 1070

\*Service Factor = 1.15

## CEILING DIFFUSER AIR THROW DATA

CHP11-953 AND CHP11-1353

Model Number	Air Volume		Effective Throw Range			
			RTD11 Step Down		FD11 Flush	
	m <sup>3</sup> /s	cfm	meters	feet	meters	feet
CHP11-953	1.25	2600	7.3 - 9.1	24 - 30	6.7 - 7.9	22 - 26
	1.40	3000	8.2 - 10.1	27 - 33	7.6 - 9.1	25 - 30
	1.60	3400	9.1 - 11.3	30 - 37	8.5 - 10.4	28 - 34
CHP11-1353	1.80	3800	9.1 - 11.3	30 - 37	8.5 - 10.4	28 - 34
	2.10	4400	10.4 - 12.8	34 - 42	9.8 - 12.2	32 - 40
	2.35	5000	11.6 - 14.3	38 - 47	11.0 - 13.7	36 - 45

\*Four sides open and terminating at a point where conditioned air velocity has decreased to 0.25 m/s (50 feet per minute).

CHP11-1853 AND CHP11-2753

Model Number	Air Volume		Effective Throw Range			
			RTD11 Step Down		FD11 Flush	
	m <sup>3</sup> /s	cfm	meters	feet	meters	feet
CHP11-1853	2.45	5200	13.1 - 15.8	43 - 52	14.0 - 15.8	46 - 52
	2.85	6000	13.7 - 16.5	45 - 54	14.6 - 16.8	48 - 55
	3.20	6000	14.3 - 17.1	47 - 56	15.2 - 17.7	50 - 58
CHP11-2753	3.30	7000	13.1 - 15.8	43 - 52	15.5 - 18.3	51 - 60
	3.80	8000	13.7 - 16.5	45 - 54	16.2 - 18.9	53 - 62
	4.25	9000	14.3 - 17.1	47 - 56	16.8 - 19.5	55 - 64

\*Four sides open and terminating at a point where conditioned air velocity has decreased to 0.25 m/s (50 feet per minute).

## POWER EXHAUST FANS PERFORMANCE

CHP11-1853

Air Volume Exhausted		Return Air System Static Pressure	
m <sup>3</sup> /s	cfm	Pa	inches water gauge
200	4200	0	0
1.80	3800	12	.05
1.60	3400	25	.10
1.40	3000	37	.15
1.25	2600	50	.20
0.80	1700	62	.25

CHP11-2753

Air Volume Exhausted		Return Air System Static Pressure	
m <sup>3</sup> /s	cfm	Pa	inches water gauge
280	5900	0	0
2.50	5300	12	.05
2.20	4700	25	.10
1.95	4100	37	.15
1.60	3400	50	.20
1.20	2500	62	.25

**BLOWER DATA**  
**CHP11-953 AND CHP11-1353 ACCESSORY AIR RESISTANCE**

Model Number	Air Volume		*Total Air Resistance – Pa (inches water gauge)								
			Power Saver	RTD Combination Supply and Return			FD Ceiling Supply and Return	2 Row Hot Water Coil	Electric Heater		
	m <sup>2</sup> /s	cfm		2 Ends Open	2 Ends 1 Side Open	All Ends Sides Open			One Element	Two Elements	Three Elements
CHP11-953	1.25	2600	6 (0.023)	60 (0.24)	52 (0.21)	45 (0.18)	42 (0.17)	90 (0.36)	20 (0.08)	57 (0.23)	97 (0.39)
	1.30	2800	6 (0.025)	67 (0.27)	60 (0.24)	52 (0.21)	50 (0.20)	99 (0.40)	22 (0.09)	65 (0.26)	109 (0.44)
	1.40	3000	9 (0.035)	80 (0.32)	72 (0.29)	62 (0.25)	62 (0.25)	109 (0.44)	25 (0.10)	70 (0.28)	122 (0.49)
	1.50	3200	11 (0.045)	102 (0.41)	92 (0.37)	80 (0.32)	77 (0.31)	119 (0.48)	27 (0.11)	77 (0.31)	132 (0.53)
	1.60	3400	14 (0.055)	124 (0.50)	112 (0.45)	97 (0.39)	92 (0.37)	129 (0.52)	30 (0.12)	82 (0.33)	144 (0.58)
	1.70	3600	16 (0.065)	152 (0.61)	134 (0.54)	119 (0.48)	109 (0.44)	139 (0.56)	32 (0.13)	90 (0.36)	157 (0.63)
	1.80	3800	19 (0.075)	182 (0.73)	157 (0.63)	142 (0.57)	127 (0.51)	149 (0.60)	35 (0.14)	94 (0.38)	167 (0.67)
CHP11-1353	1.70	3600	5 (0.02)	85 (0.34)	70 (0.28)	55 (0.22)	35 (0.14)	85 (0.34)	30 (0.12)	57 (0.23)	99 (0.40)
	1.80	3800	7 (0.029)	99 (0.40)	80 (0.32)	65 (0.26)	45 (0.18)	92 (0.37)	32 (0.13)	62 (0.25)	111 (0.45)
	1.90	4000	9 (0.037)	109 (0.44)	90 (0.36)	72 (0.29)	52 (0.21)	97 (0.39)	37 (0.15)	70 (0.28)	124 (0.50)
	2.00	4200	11 (0.044)	122 (0.49)	99 (0.40)	82 (0.33)	60 (0.24)	102 (0.41)	40 (0.16)	77 (0.31)	134 (0.54)
	2.10	4400	13 (0.052)	134 (0.54)	109 (0.44)	92 (0.37)	67 (0.27)	112 (0.45)	45 (0.18)	82 (0.33)	147 (0.59)
	2.15	4600	15 (0.059)	149 (0.60)	122 (0.49)	104 (0.42)	77 (0.31)	119 (0.48)	47 (0.19)	90 (0.36)	159 (0.64)
	2.25	4800	17 (0.067)	162 (0.65)	132 (0.53)	114 (0.46)	87 (0.35)	127 (0.51)	52 (0.21)	97 (0.39)	169 (0.68)
	2.35	5000	18 (0.074)	172 (0.69)	144 (0.58)	124 (0.50)	97 (0.39)	134 (0.54)	57 (0.23)	104 (0.42)	182 (0.73)

\* Air Resistance shown must be added to system static pressure when selecting blower speed and motor output requirements.  
 NOTE – Diffuser Air Resistance includes grille and 90 cm (3 ft.) of duct work.

**CHP11-1853 AND CHP11-2753 ACCESSORY AIR RESISTANCE**

Model Number	Air Volume		*Total Air Resistance – Pa (inches water gauge)						
			Power Saver	RTD Combination Ceiling Supply and Return			FD Ceiling Supply and Return	2 Row Hot Water Coil	Electric Heater All Models
	m <sup>2</sup> /s	cfm		2 Sides Open	3 Sides Open	4 Sides Open			
CHP11-1853	2.45	5200	10 (0.041)	144 (0.058)	117 (0.47)	104 (0.42)	75 (0.30)	32 (0.13)	10 (0.04)
	2.55	5400	10 (0.042)	154 (0.62)	127 (0.51)	112 (0.45)	82 (0.33)	35 (0.14)	10 (0.04)
	2.65	5600	10 (0.043)	164 (0.66)	137 (0.55)	119 (0.48)	90 (0.36)	37 (0.15)	10 (0.04)
	2.75	5800	11 (0.044)	174 (0.70)	147 (0.59)	127 (0.51)	97 (0.39)	40 (0.16)	12 (0.05)
	2.85	6000	11 (0.045)	189 (0.76)	157 (0.63)	137 (0.55)	104 (0.42)	42 (0.17)	12 (0.05)
	2.95	6200	12 (0.047)	199 (0.80)	169 (0.68)	147 (0.59)	114 (0.46)	45 (0.18)	12 (0.05)
	3.00	6400	12 (0.048)	214 (0.86)	179 (0.72)	157 (0.63)	124 (0.50)	47 (0.19)	12 (0.05)
	3.10	6600	12 (0.050)	229 (0.92)	191 (0.77)	167 (0.67)	134 (0.54)	50 (0.20)	15 (0.06)
	3.20	6800	13 (0.052)	246 (0.99)	206 (0.83)	179 (0.72)	144 (0.58)	52 (0.21)	15 (0.06)
	3.30	7000	13 (0.054)	259 (1.04)	216 (0.98)	189 (0.76)	154 (0.62)	55 (0.22)	15 (0.06)
CHP11-2753	3.40	7200	14 (0.056)	271 (1.09)	229 (0.92)	199 (0.80)	164 (0.66)	57 (0.23)	15 (0.06)
	3.30	7000	9 (0.035)	104 (0.42)	82 (0.33)	77 (0.31)	92 (0.37)	70 (0.28)	17 (0.07)
	3.40	7200	9 (0.036)	112 (0.45)	90 (0.36)	82 (0.33)	97 (0.39)	72 (0.29)	17 (0.07)
	3.50	7400	9 (0.037)	119 (0.48)	97 (0.39)	87 (0.35)	102 (0.41)	75 (0.30)	17 (0.07)
	3.60	7600	9 (0.038)	127 (0.51)	104 (0.42)	92 (0.37)	107 (0.43)	77 (0.31)	17 (0.07)
	3.70	7800	10 (0.039)	137 (0.55)	114 (0.46)	99 (0.40)	117 (0.47)	80 (0.32)	20 (0.08)
	3.80	8000	10 (0.041)	147 (0.59)	122 (0.49)	107 (0.43)	124 (0.50)	82 (0.33)	20 (0.08)
	3.85	8200	11 (0.043)	157 (0.63)	132 (0.53)	114 (0.46)	132 (0.53)	87 (0.38)	20 (0.08)
	3.95	8400	11 (0.045)	167 (0.67)	139 (0.56)	122 (0.49)	139 (0.56)	90 (0.36)	22 (0.09)
	4.05	8600	12 (0.047)	177 (0.71)	149 (0.60)	129 (0.52)	147 (0.59)	92 (0.37)	22 (0.09)
	4.15	8800	12 (0.048)	189 (0.76)	157 (0.63)	137 (0.55)	157 (0.63)	97 (0.39)	25 (0.11)
	4.25	9000	12 (0.050)	196 (0.79)	167 (0.67)	144 (0.58)	164 (0.66)	102 (0.41)	25 (0.11)
4.35	9200	13 (0.052)	209 (0.84)	174 (0.70)	152 (0.61)	172 (0.69)	104 (0.42)	27 (0.11)	
4.45	9400	13 (0.054)	216 (0.87)	182 (0.73)	159 (0.64)	179 (0.72)	109 (0.44)	27 (0.11)	

\* Air Resistance shown must be added to system static pressure when selecting blower speed and motor output requirements.  
 NOTE – Diffuser Air Resistance includes grille and 90 cm (3 ft.) of duct work.

# CHP11-953-1353-1853-2753 HOT WATER COIL PRESSURE DROP

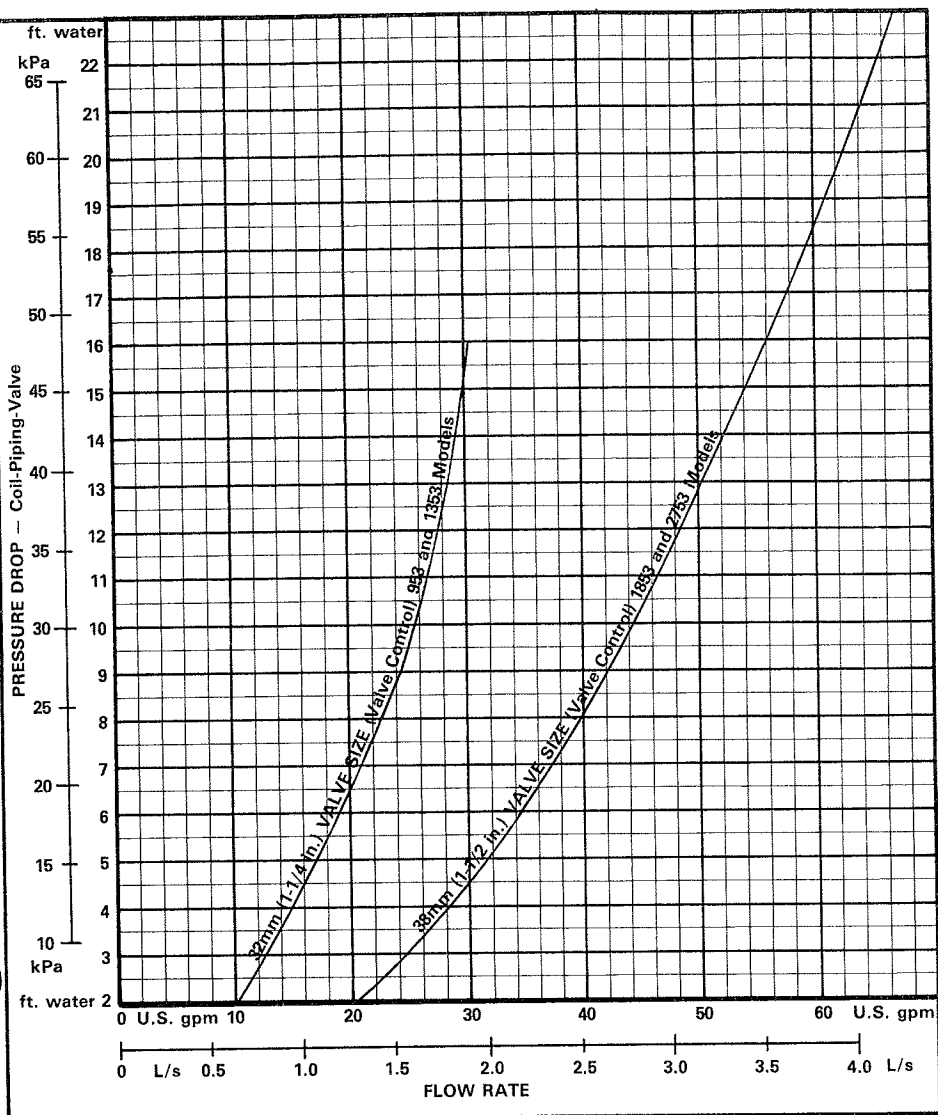

**HOT WATER WITH GLYCOL SOLUTION  
PRESSURE DROP CORRECTION FACTOR CHART**  
Multiply figure in pressure drop chart by  
correction factor below.

% Glycol	Correction Factor
0	1.00
10	1.07
20	1.14
30	1.22
40	1.31
50	1.40

## MODULATING VALVE CONTROL SYSTEM PIPING

CHP11-953 AND 1353

CHP11-1853 AND 2753

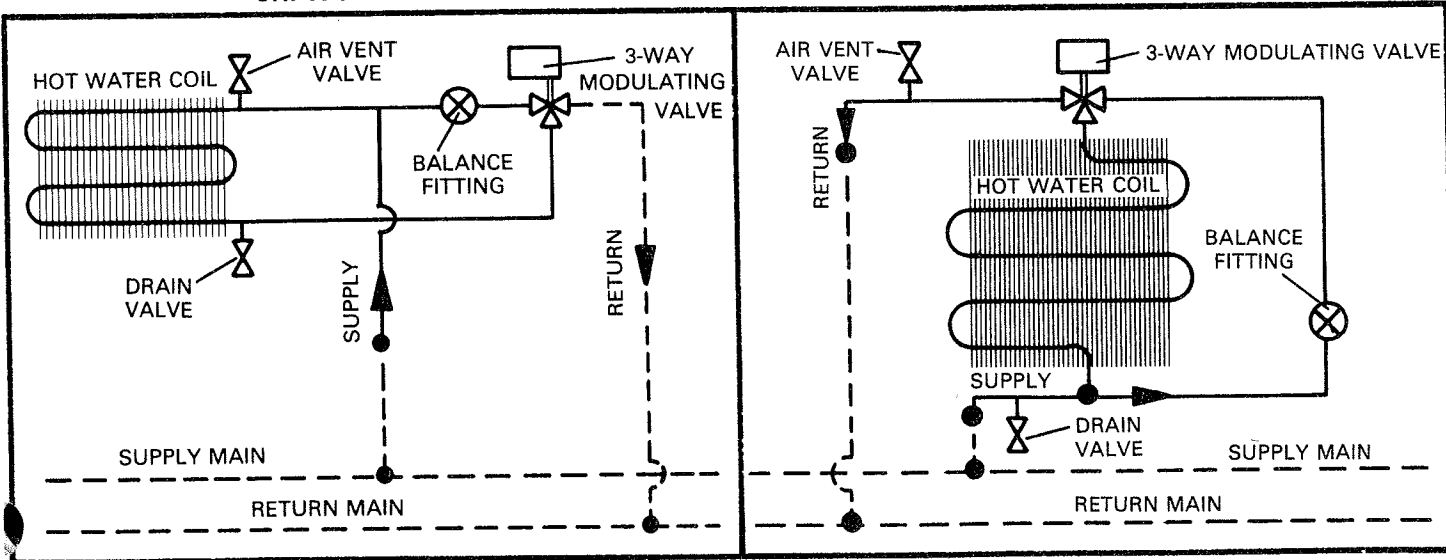

———— PIPING AND CONTROLS FURNISHED AND FACTORY INSTALLED

- - - - PIPING FURNISHED BY INSTALLER

### CHP11-953 (HWC11-95) HOT WATER HEATING CAPACITY

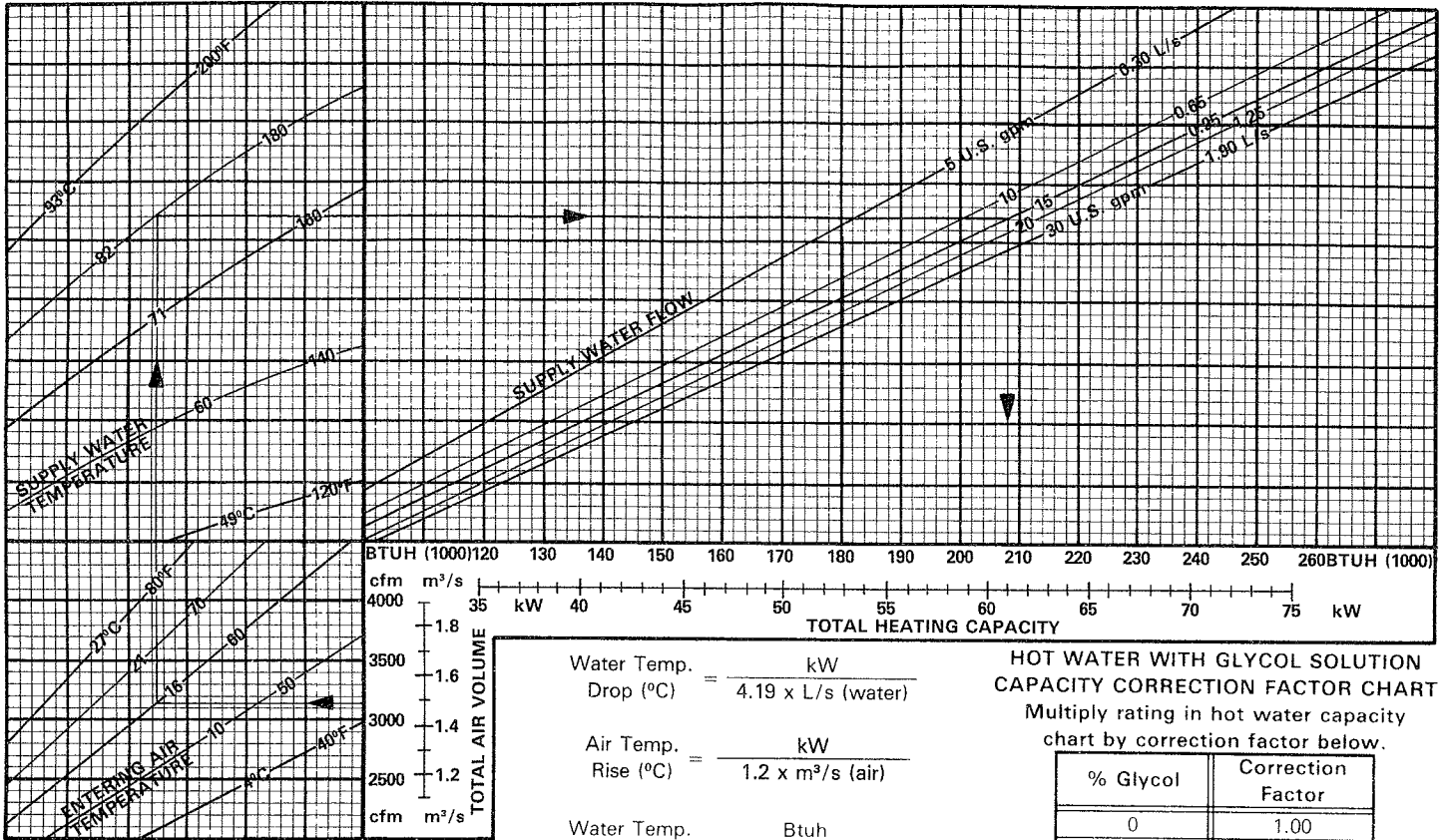

### CHP11-1353 (HWC11-135) HOT WATER HEATING CAPACITY

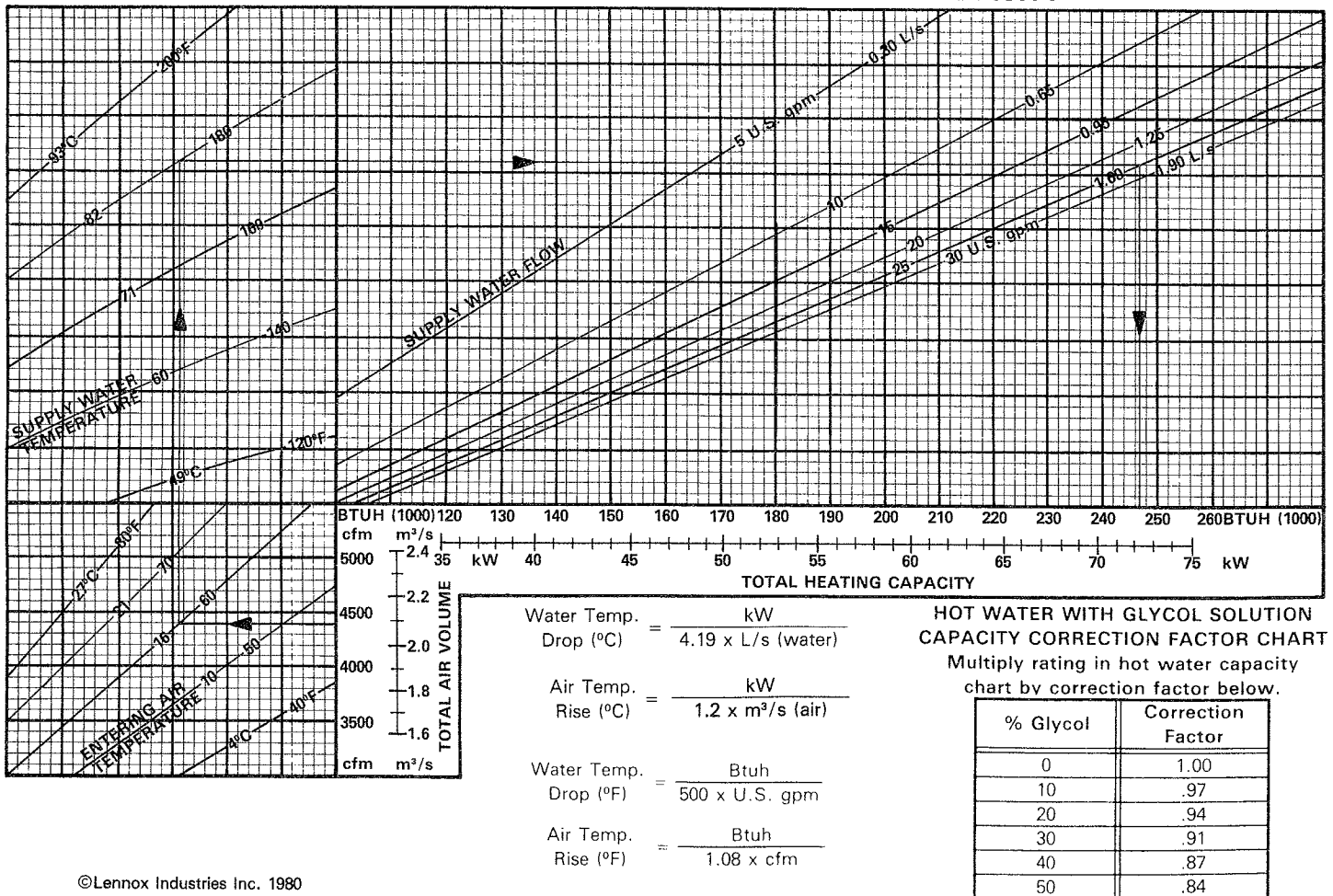



## CHP11-1853 (HWC11-185) HOT WATER HEATING CAPACITY

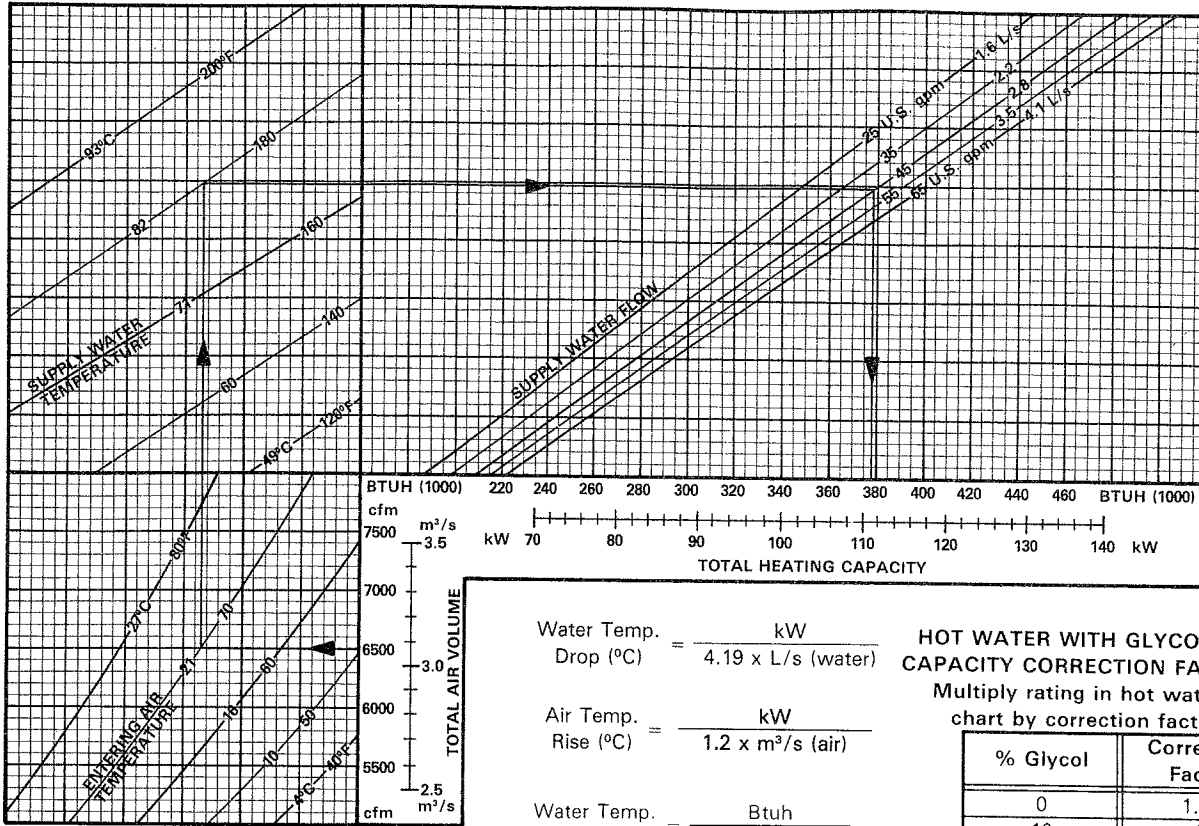

## CHP11-2753 (HWC11-275) HOT WATER HEATING CAPACITY

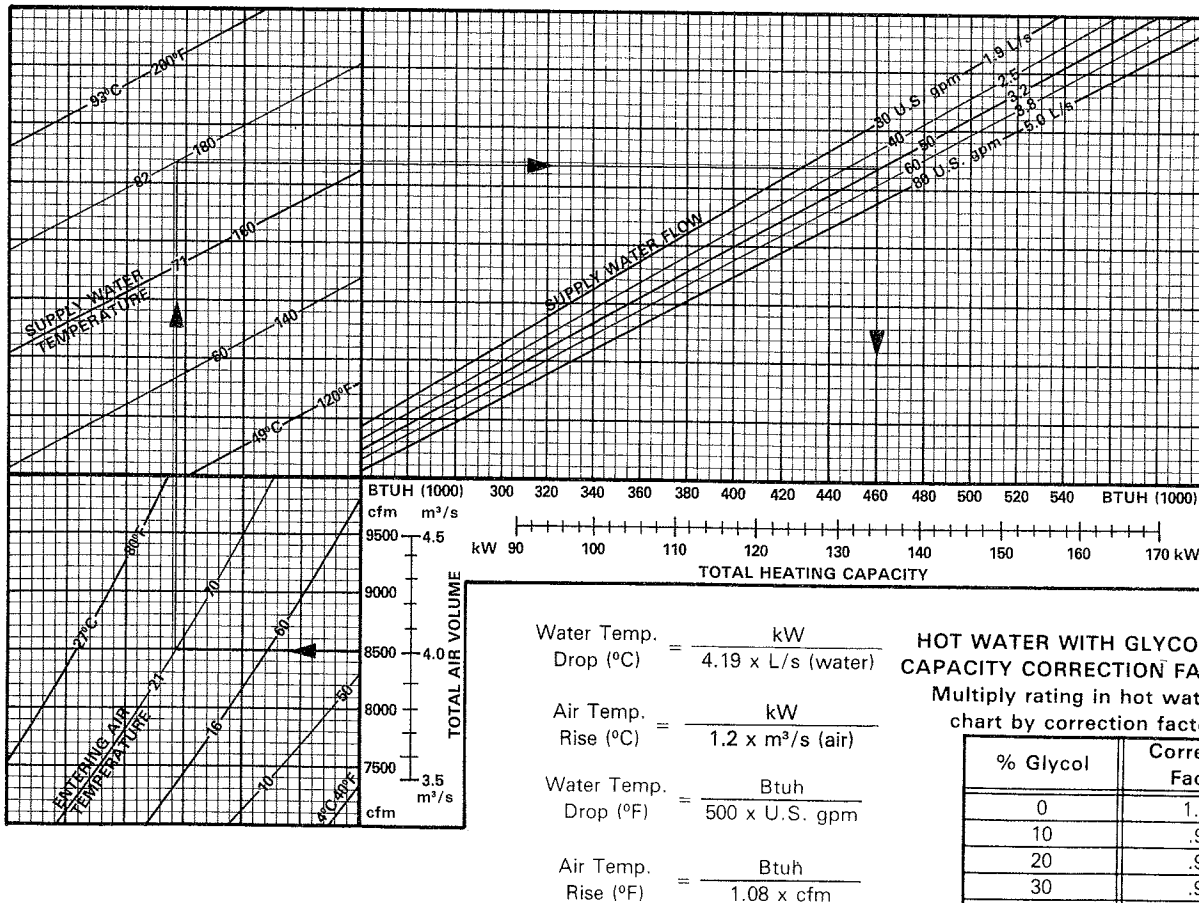

# CONTROL SELECTION FLOW CHART

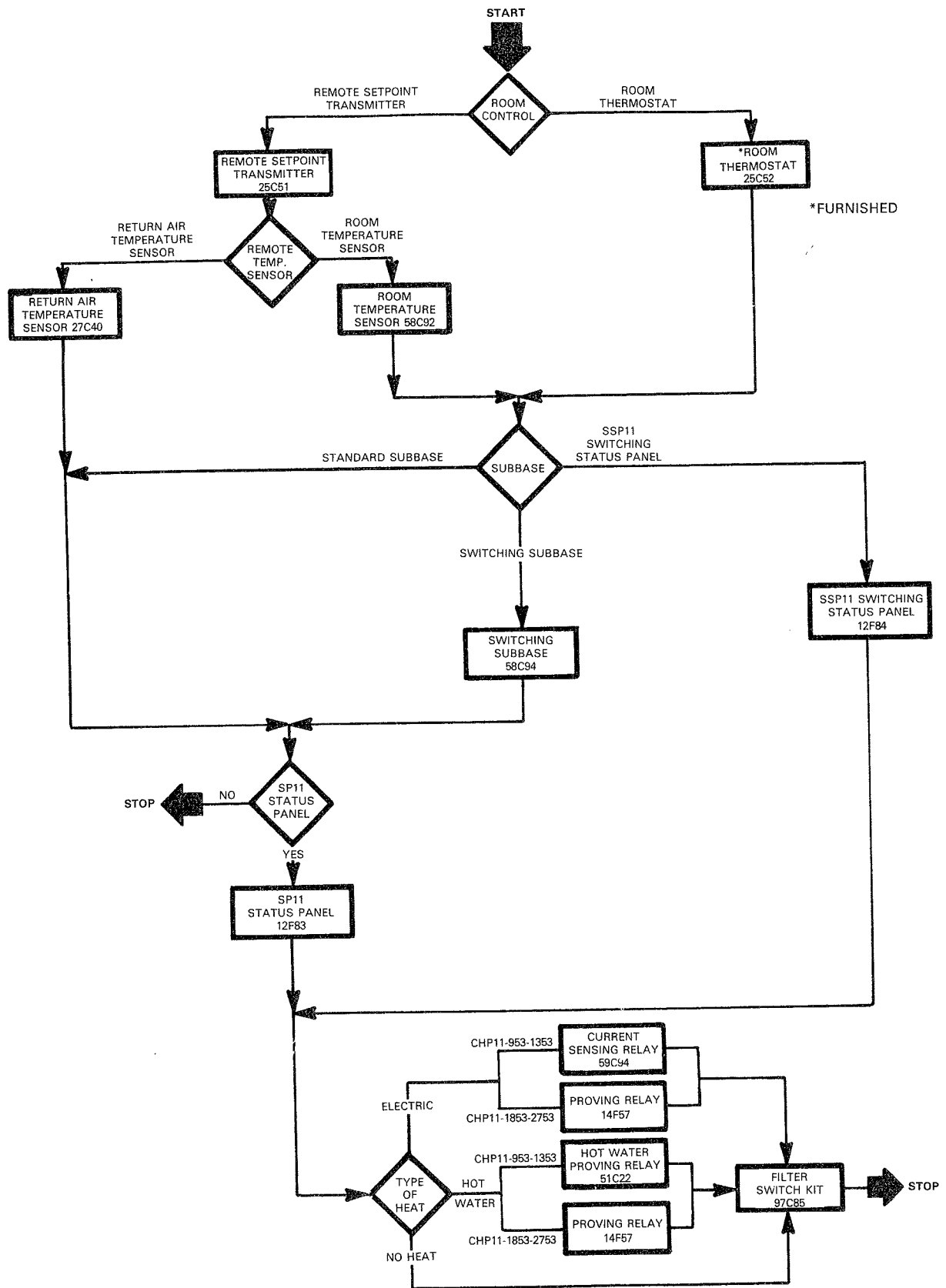

\*FURNISHED

**LEGEND**



DECISION POINT



ORDERING NUMBER

## GUIDE SPECIFICATIONS

Prepared for the guidance of architects, consulting engineers and mechanical contractors.

**General** — Furnish and install a single package air to air direct expansion mechanical heat pump system complete with automatic controls. The single package unit shall be a standard product of a firm regularly engaged in the manufacture of heating-cooling equipment.

The installed weight shall not be more than . . . . . kg (lbs.). Entire unit shall have a width of not more than . . . . . mm (inches), a depth of not more than . . . . . mm (inches) and an overall height of not more than . . . . . mm (inches). The equipment shall be shipped completely factory assembled, precharged, piped and wired internally ready for field connections. In addition, manufacturer shall test operate system at the factory before shipment.

**Roof Mounting Frame** — Furnish and install a steel roof mounting frame for bottom or end discharge and return air duct connection. It shall mate to the bottom perimeter of the equipment. When flashed into the roof it shall make a unit mounting curb and provide weatherproof duct connection and entry into the conditioned area. Flashing shall be the responsibility of a roofing contractor.

**Air Distribution** — Equipment shall be capable of bottom or end handling of conditioned air. All air distribution ducts shall be fiberglass or galvanized steel insulated with . . . . . mm (inch) thick . . . . . kg/m<sup>3</sup> (lb./ft.<sup>3</sup>) density fiberglass or equivalent.

Furnish and install a (flush or stepdown) optional combination ceiling supply and return air grille. It shall be capable of not less than . . . . . m (ft.) radius of effective throw.

**Cooling System** — The total certified cooling capacity shall not be less than . . . . . kW (Btuh) with an indoor coil air volume of . . . . . m<sup>3</sup>/s (cfm), an entering wet bulb air temperature of . . . . . °C (°F), an entering dry bulb air temperature of . . . . . °C (°F) and an outdoor coil entering air temperature of . . . . . °C (°F). The compressor power input shall not exceed . . . . . kW at these conditions.

**Heating System** — The total certified heating capacity shall not be less than . . . . . kW (Btuh) with an indoor coil air volume of . . . . . m<sup>3</sup>/s (cfm), an entering dry bulb air temperature of . . . . . °C (°F) and an outdoor coil entering air temperature of . . . . . °C (°F). The total compressor power input shall not exceed . . . . . kW at the above conditions.

The coils shall be non-ferrous construction with aluminum fins mechanically bonded to durable copper tubes. Coils shall be pressure leak tested. Coil face area shall be not less than . . . . . m<sup>2</sup> (sq. ft.) (indoor coil) and . . . . . m<sup>2</sup> (sq. ft.) (outdoor coil).

The dual compressors shall be internally spring mounted and have positive crankshaft lubrication, discharge muffler, internal solid-state temperature sensors, immersible crankcase heater and overload protection. The refrigeration system shall have suction and discharge line service gauge ports, high pressure switch, discharge temperature thermostat, check and expansion valves, reversing valves, accumulator, drier and full refrigerant charge.

**Additive Electric Heaters** — The certified total heating capacity output shall be . . . . . kW (Btuh) at . . . . . volts power supply.

Optional electric heaters shall be available. Heating elements shall be nichrome bare wire exposed directly to the air stream. Time delays shall bring the elements on and off in sequence with a time delay between elements. Limit controls shall provide overload and short circuit protection.

**Hot Water Heat** — The certified total heating capacity shall be . . . . . kW (Btuh) with a heating coil air volume of . . . . . m<sup>3</sup>/s (cfm), at water entering temperature of . . . . . °C (°F), a water flow rate of . . . . . L/s (U.S. gpm) and an entering air temperature of . . . . . °C (°F). A three way modulating water valve shall be furnished. The coils shall be non-ferrous construction with aluminum fins mechanically bonded to copper tubes. Factory installed freeze-stat shall provide freeze-up protection. Coils shall be factory pressure leak tested.

**Electronic Control System** — Shall provide room thermostat, discharge air temperature sensor, logic panel, modulating damper actuator and related accessories to automatically operate the mechanical equipment through the heating or cooling and ventilating cycles as required.

**Cabinet** — Shall be galvanized steel with a baked-on outdoor enamel paint finish. Cabinet panels where conditioned air is handled shall be fully insulated to prevent sweating and minimize sound. Openings shall be provided for power connection entry. Base shall have drainage holes. Lifting lugs shall be provided for rigging.

**Service Access** — All components, wiring and inspection areas shall be completely accessible through removable panels.

**Supply Air Blower** — Centrifugal supply air blower shall have permanently lubricated ball bearings, adjustable belt drive and motor mount where belt tension can be easily adjusted. The entire assembly shall be floated on resilient rubber mounts. Blower wheel shall be statically and dynamically balanced. Blower shall be capable of delivering . . . . . m<sup>3</sup>/s (cfm) at an external static pressure of . . . . . Pa (inches water gauge) requiring . . . . . kW (hp) motor output and . . . . . rev./min.

**Outdoor Coils Fans** — Twin propeller type outdoor coil fans shall discharge vertically and be direct driven by a . . . . . kW (hp) output motor. Fan motor shall be equipped with ball bearings, permanently lubricated, inherently protected and equipped with rain shield. Fan shall have a safety guard.

**Air Filters** — 25mm (1 in.) thick disposable frame type fiberglass media filters shall have not less than . . . . . m<sup>2</sup> (sq. ft.) of free area.

**POWER SAVER** — Furnish and install complete with controls an optional mechanically linked air mixing damper assembly including outdoor air and recirculated air dampers. The assembly shall mount within the confines of the unit cabinet and provide for the introduction of outside air for minimum ventilation and free cooling. Outdoor air intake shall mount external to the unit cabinet. Damper motor shall be 24 volt, modulating spring return. Controls shall include discharge air temperature sensor and adjustable enthalpy control.

**Power Exhaust Air Dampers** — Shall be available on CHP11-1853 and CHP11-2753 models. Direct drive propeller type fans shall exhaust air through pressure relief dampers. Motors shall be overload protected. Pressure operated dampers shall install within the unit and prevent blow back and outdoor air infiltration during the fan off cycle. Damper blades shall ride in nylon bearings and be gasketed for tight seal and quiet operation.

**Gravity Exhaust Dampers** — Pressure operated dampers shall install within the unit. Damper blades shall ride in nylon bearings and be gasketed for tight seal and quiet operation.

**Fresh Air Dampers** — Outdoor air damper section shall control outdoor air requirements and be available for manual or automatic operation. Dampers shall be adjustable for air quantities up to 25%. OAD11 models shall include cleanable air filter.

**Remote Status Panel** — Shall be available for installation within the conditioned area to observe equipment operation. The panel shall include signal lights for Cool Mode, Compressor 1, Compressor 2, No Heat and Filter.

**Remote Switching Status Panel** — Shall be available for installation within the conditioned area to control and observe equipment operation. The panel shall include signal lights for Cool Mode, Heat Mode, Compressor 1, Compressor 2, No Heat and Filter. System selector switch and fan switch shall provide operational mode and blower operation. After hours timer switch shall override night setback controls and provide normal operation for time period set.

**Night Setback Controls** — Complete controls shall be available to program the equipment for day-night operation.