

Indice	DATE	NOM	MODIFICATIONS
LENNOX[®]			
<i>Littlewoods Torquay</i>			
(1) BGK 050 HD LENNOX UK	Dessine: CTO Date: 03.05.04	PAGE DE GARDE	236328 0/11

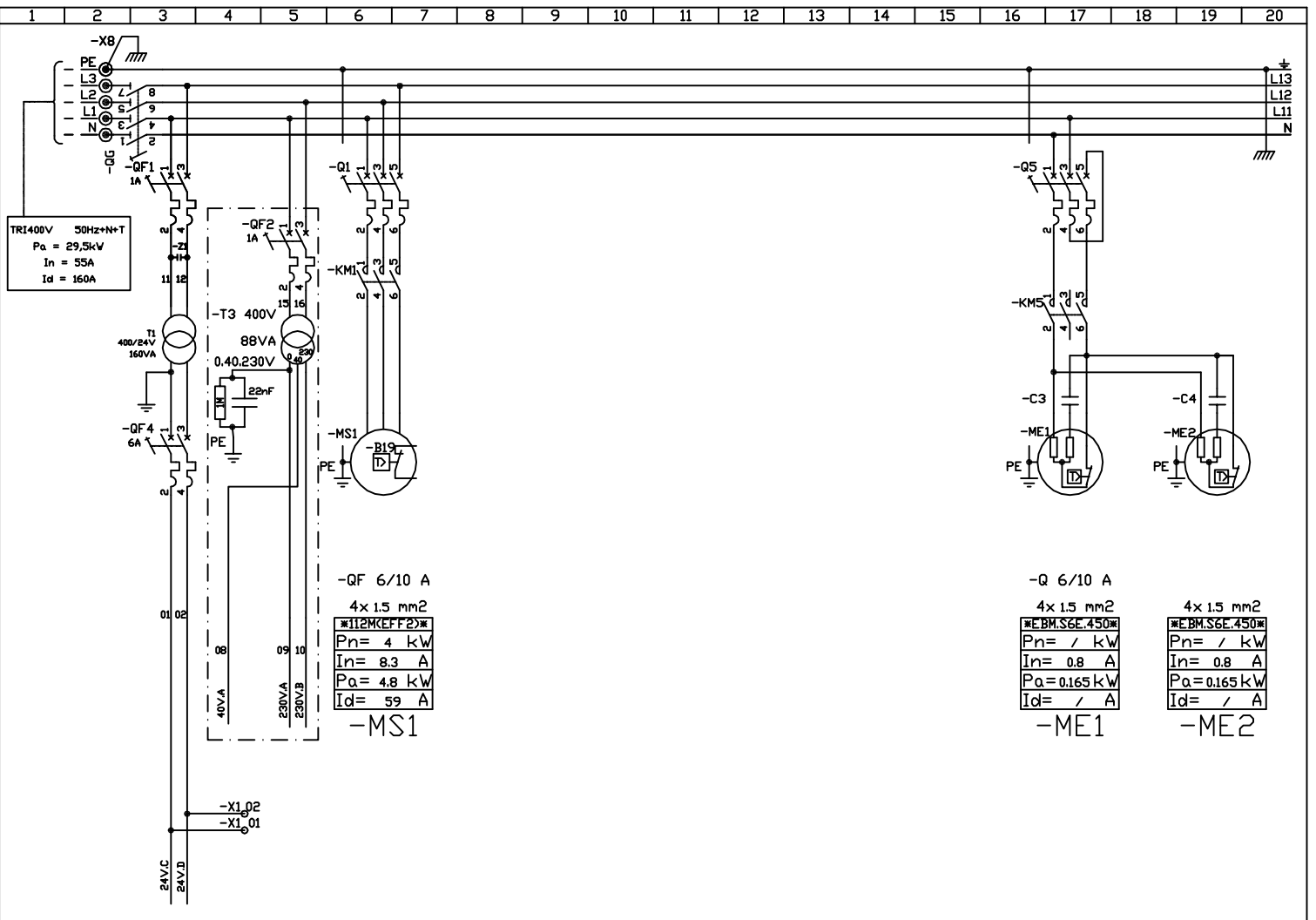

-QF 6/10 A
4x 1.5 mm²
I12M(CFF2)
Pn= 4 kW
In= 8.3 A
Pa= 4.8 kW
Id= 59 A
-MS1

-Q 6/10 A
4x 1.5 mm²
E.BM.S6E.450
Pn= / kW
In= 0.8 A
Pa= 0.165 kW
Id= / A
-ME1
-ME2

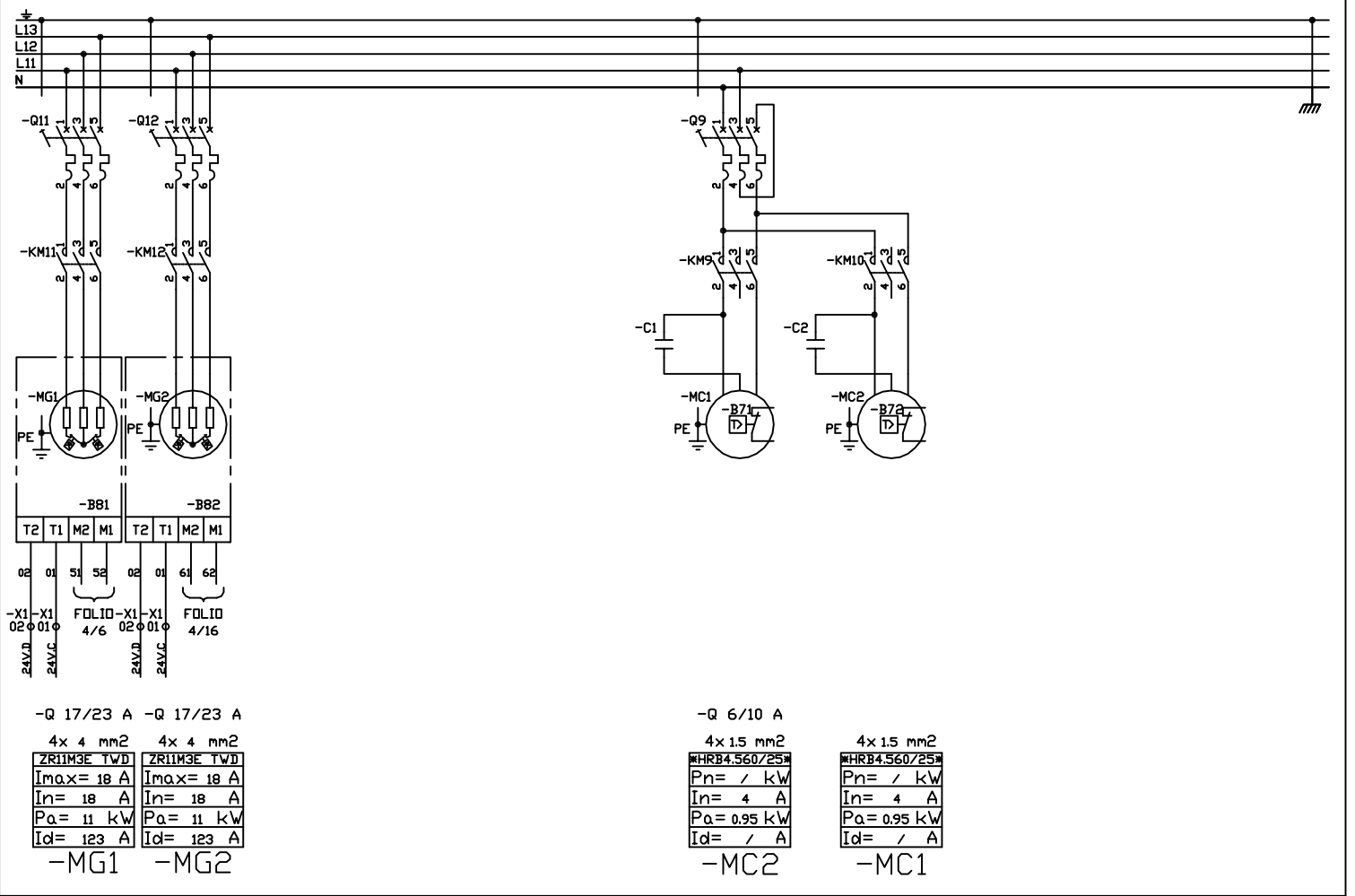

-Q 17/23 A -Q 17/23 A
4x 4 mm² 4x 4 mm²
ZR11M3E TWD *ZR11M3E TWD*
Imax= 18 A Imax= 18 A
In= 18 A In= 18 A
Pa= 11 kW Pa= 11 kW
Id= 123 A Id= 123 A
-MG1 -MG2

-Q 6/10 A
4x 1.5 mm² 4x 1.5 mm²
HRB4.560/25 *HRB4.560/25*
Pn= / kW Pn= / kW
In= 4 A In= 4 A
Pa= 0.95 kW Pa= 0.95 kW
Id= / A Id= / A
-MC2 -MC1

- BM 50

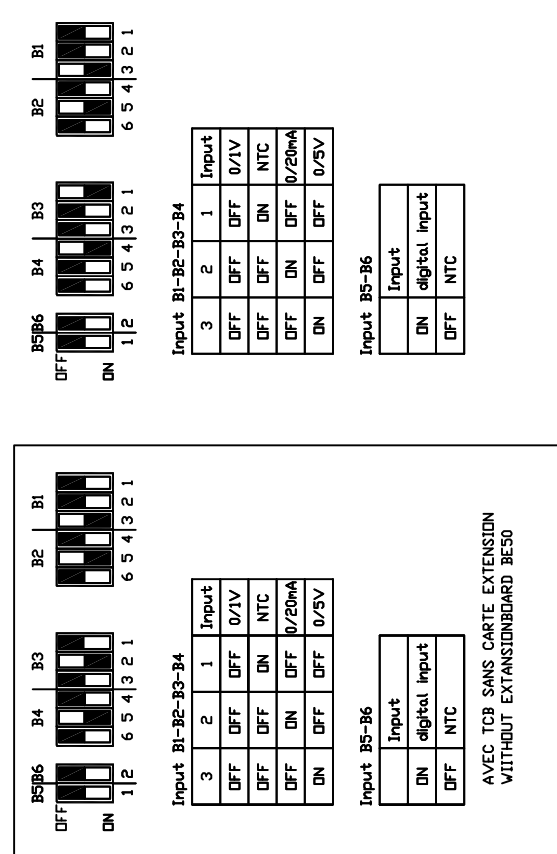
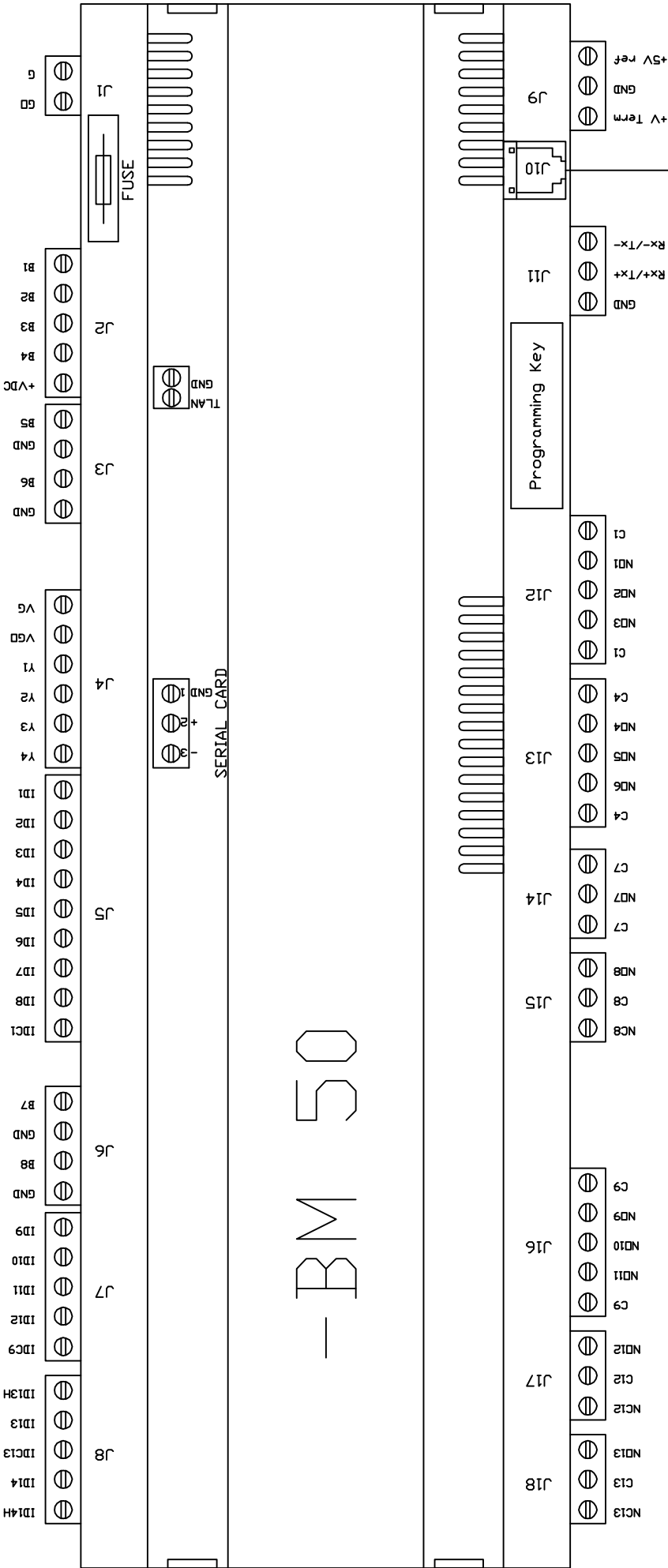

AVEC TCB SANS CARTE EXTENSION
WITHOUT EXTENSIONBOARD BE50

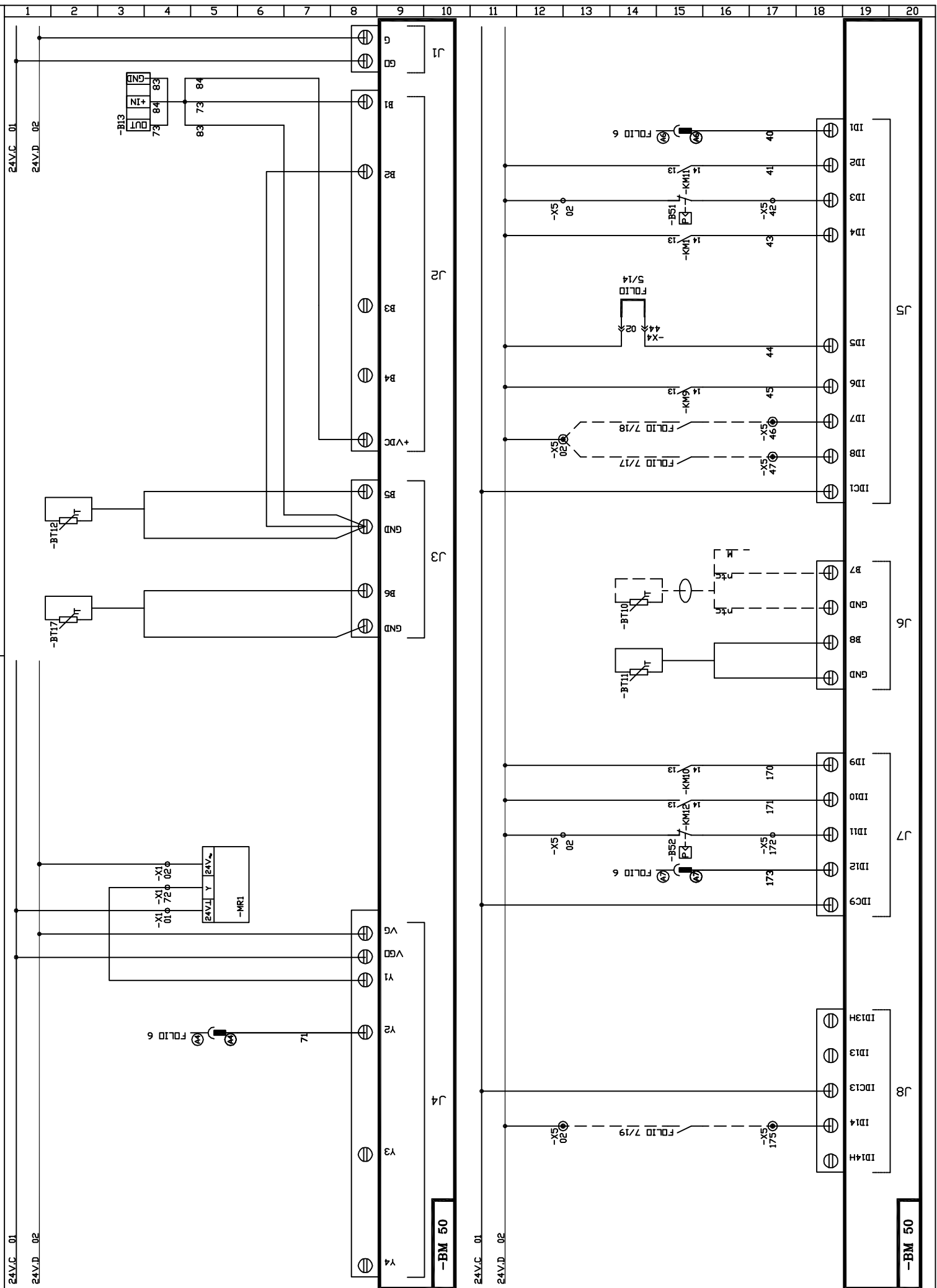

Indice	DATE	NOM	MODIFICATIONS

(1) BCK 050 HD
Entrées Automate CLIMATIC 50
Climatic 50 Controller Input

Dessine: CTO
Date: 03.05.04



236328 3/11

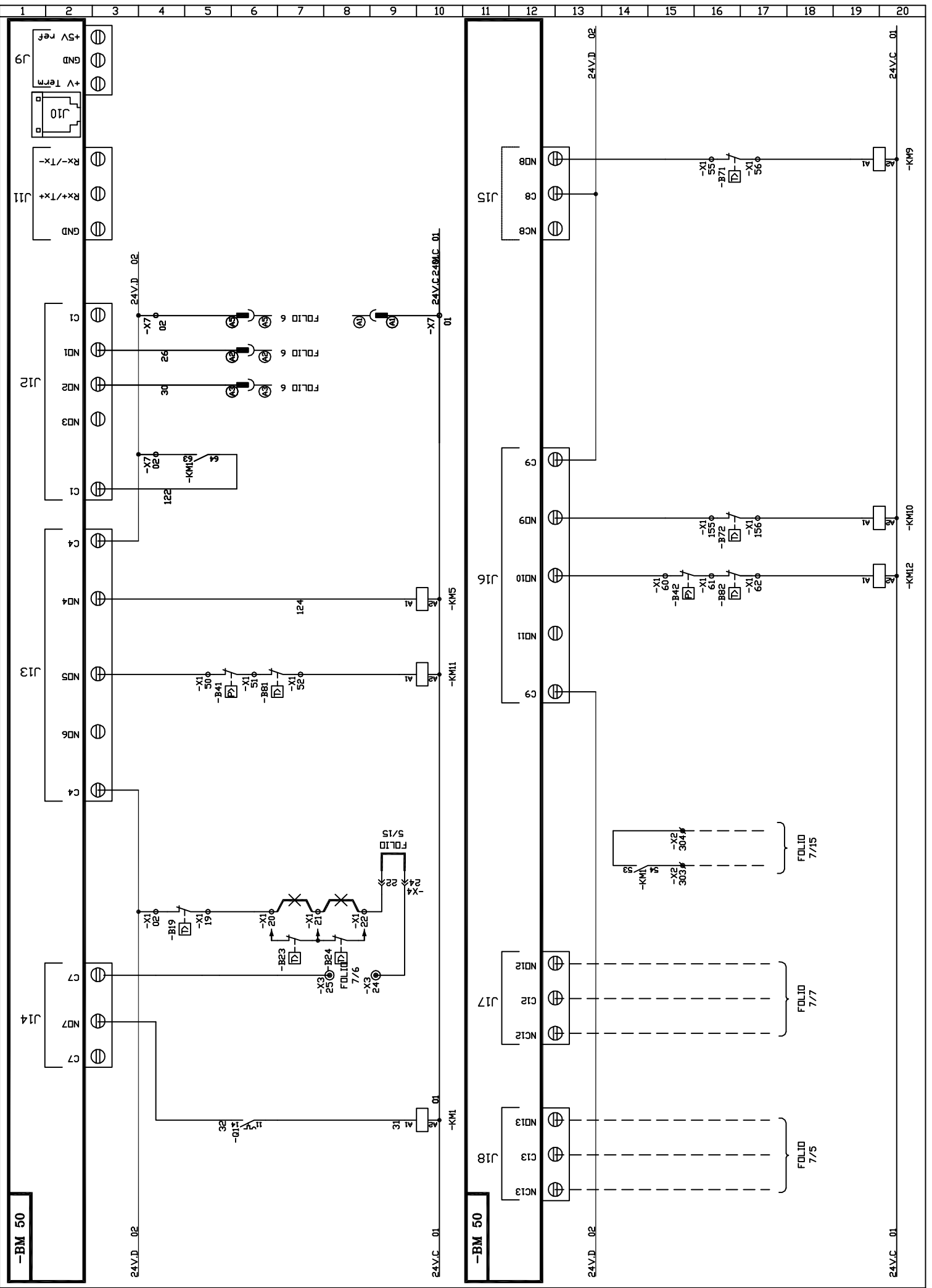

-BM 50

-BM 50

(1) BCK 050 HD
Sorties Automate CLIMATIC 50
Climatic 50 Controller Outputs

Dessine: CTO
Date: 03.05.04

LENNOX
USINE DE LONGVIC

236328 4/11

Indice	DATE	NOM	MODIFICATIONS

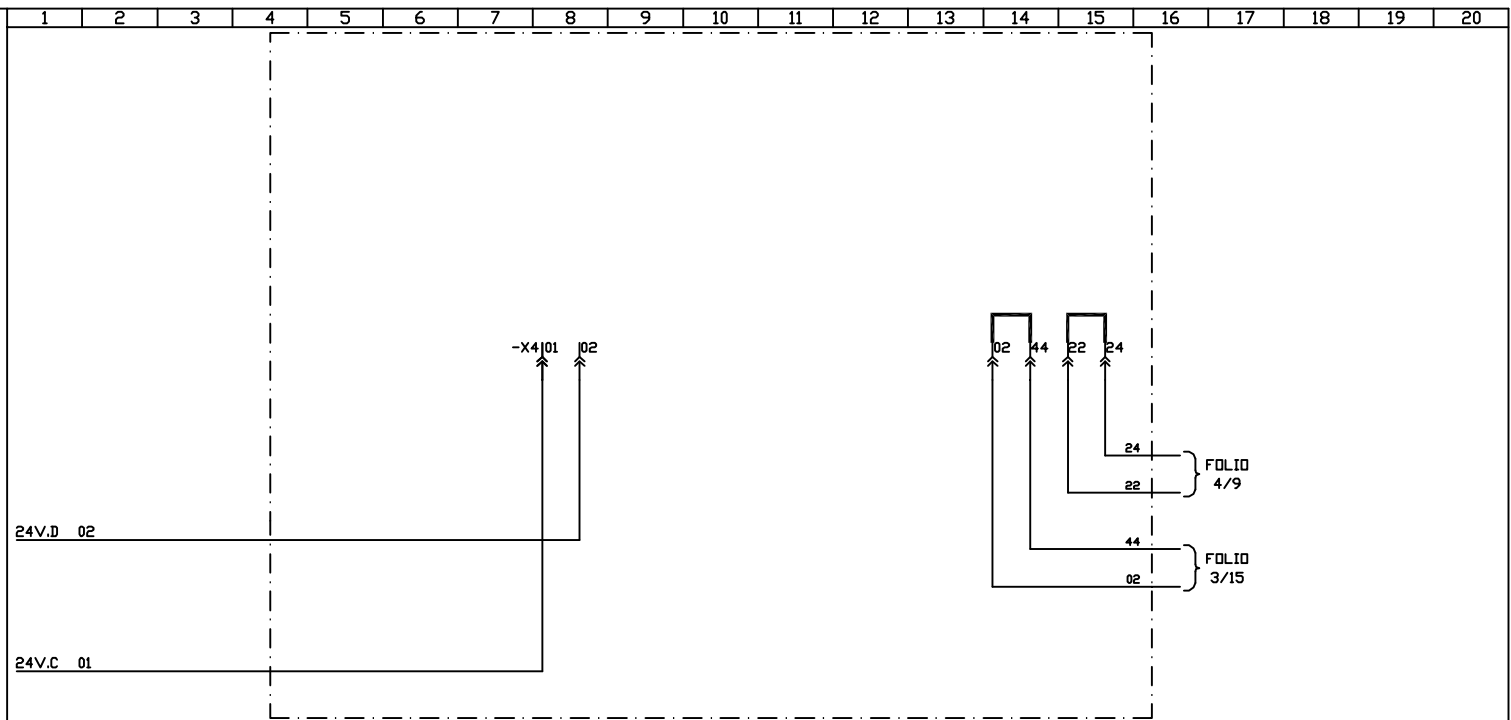

REPERE	REFERENCE	CODE	Nb
-QF2	C60N 1A BIPOL COURBE D	4480589E	1
-T3	88VA 400V/40V/230V	4430131Z	1
-RC	CIRCUIT RC 1MEGOMH - 22nF	4770012Z	1
-EF48	-EF48	4770624Z	1

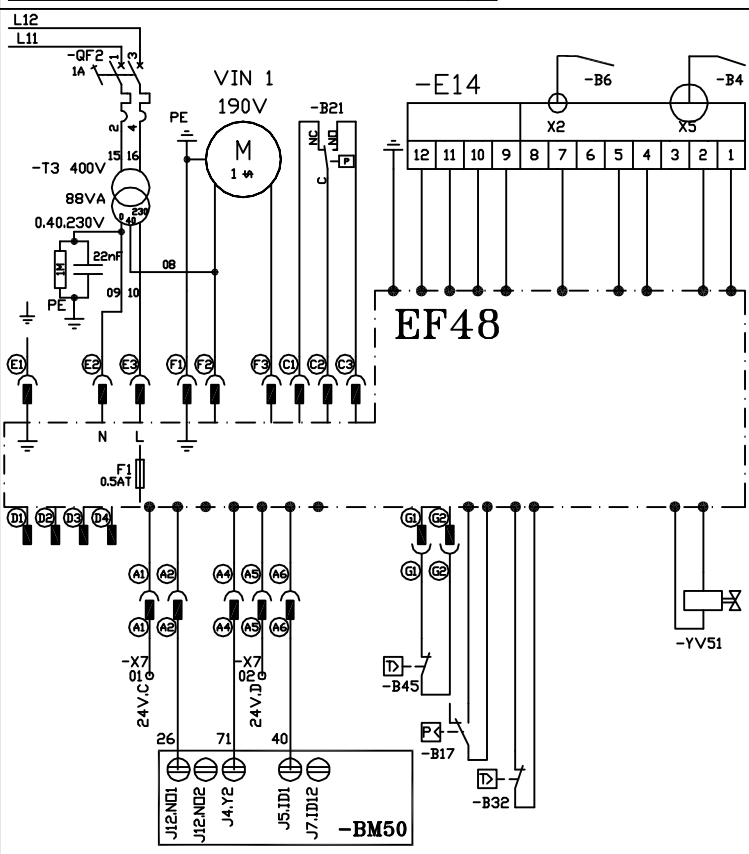

Indice	DATE	NOM	MODIFICATIONS

(1) BCK 050 HD
Kit chauffage
GAS

Dessine: CTO
Date: 03.05.04



236328 6/11
USINE DE LONGVIC

