Congratulations you have made a wise choice and we feel sure that it will meet your expectations

CONTENTS	PAGE
• GENERAL DESCRIPTION	2-5
• DENOMINATION	6
• PRODUCT RANGE	7-8
• PHYSICAL DATA	9-11
• ELECTRICAL DATA	12-14
• FAN PERFORMANCES	15-16
• SOUND PRESSURE / SOUND POWER LEVELS	17
• CAPACITY TABLES	18-21
• UNIT DIMENSIONS	22-25
• TRANSFORMATION OF AIR DISCHARGE	26-27
• UNIT INSTALLATION	28-29
• REFRIGERANT CONNECTIONS	30-32
• ELECTRICAL CONNECTIONS	33-37
• OPERATING LIMITS	38
• OPTIONS	39-53

GENERAL DESCRIPTION

The vertical air conditioning units, range AIRCOOLAIR cooling only or heat pump are air conditioning units, of the air to air type, designed for small and medium shopping center and housing.

The unit consists on an outdoor section and an indoor one and they may be supplied either as a compact unit or as a remote split and multi-split systems.

It is also possible supply the outdoor section alone, to match with other type of indoor unit that customer needs. They are designed for installation indoors or outdoors, and adequate to work in air ducts both sections. A wide range of optionals, completed-factory assembled are also available.

FURNITURE

Made of galvanized steel sheeting with epoxy painted finish, weather proofed with high resistant to corrosion. The units are provided with metal profiles, capable of withstanding the unit and able as well of installing the unit mounted on the floor.

Both sections are thermoacoustic insulated. An insulation with a mesh protection is used for indoor units with an M1 and F1 classification, certifying that the material is auto-extinguishable and avoiding smoke formed, which may get inside the room to be conditioned.

For outdoor units, the insulation is auto-extinguishable and has a M1 classification.

COMPRESSORS

All units are provided with hermetically sealed compressors, scroll type, cooled by exhaust gas, with internal thermal insulation inside the engine, so no other additional protection is required. The compressor is fitted on vibration mountings both inside and outside.

The compressors have a screwed connection into the pipe thus they can be more easily to assembled. In heat pump units the compressors are provided, as standard, with a crankcase heater (optional for cooling only units), to assist evaporation of the coolant retained by the oil in the compressor so that a suitable lubrication can take place.

AIR FILTER

Washable air filter; auto extinguishable material with M1 classification.

FANS

Inner sections are supplied with one or two "E" or "D" centrifugal fans respectively, fans are fitted with a common axle activated through an adjustable and variable pulley belt pulley with one activating motor. The outer one and two fans are axial type.

HEAT EXCHANGERS

Made of copper tubing with aluminum corrugated swirl fins, they are designed and specially dimensioned to obtain the maximum output so as to prevent ice forming in the outer heater, extending the operating cycles to a maximum obtaining maximum output and exchange on reducing the frequency of defrosting.

COOLING CIRCUIT

Made of welded dehumidifying copper tube with plugged valves in the suction and liquid lines on both indoor and outdoor sections.

The units are supplied with high and low pressostat, with automatic reset.

Silencer fitted on the compressor discharge, and expansion system through a reducing valves. The heat pump units are equipped with dehumidifying filter to avoid liquid getting on the compressor, four way valve for reversing cycle, and one way valves.

SWITCHBOARD

Designed according to EN 60204-1 normative. With protective fuses for compressors and fans, except for the ones adjustable and variable activating motor which are supplied with an external thermic relay.

The units have a built printed circuit board which controls the unit.

CONTROL

These units range are available in two different versions, depending on the digital thermostat supplied with the unit: These versions are:

1- **Standard unit version, supplied with two wires connection digital thermostat.**

2- **VFC unit version, None thermostat included but, with possibility to install a BMS "building management systems"**

1- Standard unit version, with two wires connection.

Control made up with a printed control board and with a walled terminal thermostat to be placed in the room to be conditioned; with ambient sensor inside the terminal for the regulation of the system.

With LCD display with **alarm visualization, exclusive connection with two wires between terminal thermostat and electrical box** at the unit, possibility to adjust internal parameters, automatic restarting and intelligent defrosting control adapted to ambient conditions and room demand at each moment (for heat pump units)

Digital thermostat corresponding to the standard unit version, with two wires connection.

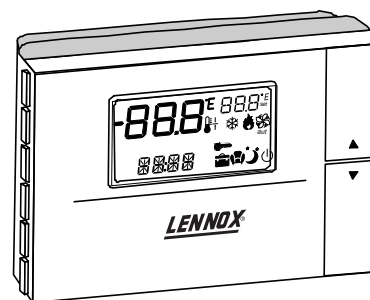

2- VFC unit version, with possibility to install a BMS "building management systems"

Control made up with a printed control board, automatically restarting and intelligent defrosting control adapted to ambient conditions and room demand at each moment (for heat pump units).

In both unit versions through the voltage free contacts supplied on, lets you to obtain the following functions:

- To obtain the alarm signal of the units such as, fan OFF, compressor OFF...
- To know the unit function MODE; Unit running on fan, cooling or heating mode, compressor ON...

Also the VFC unit version, lets you make the connection from the printed control board at the electrical box of the unit, to manage the signals functioning of the unit, fan, cooling, heating, step 1, step 2 etc... to a BMS system "building management systems", and the connections will be the digital outputs of BMS system.

GENERAL DESCRIPTION

The following outlines shows what we explain before, and corresponding of a double circuit units "D". For more details see electrical connections on this manual.

Outline of the Voltage free contact available for the standard unit version

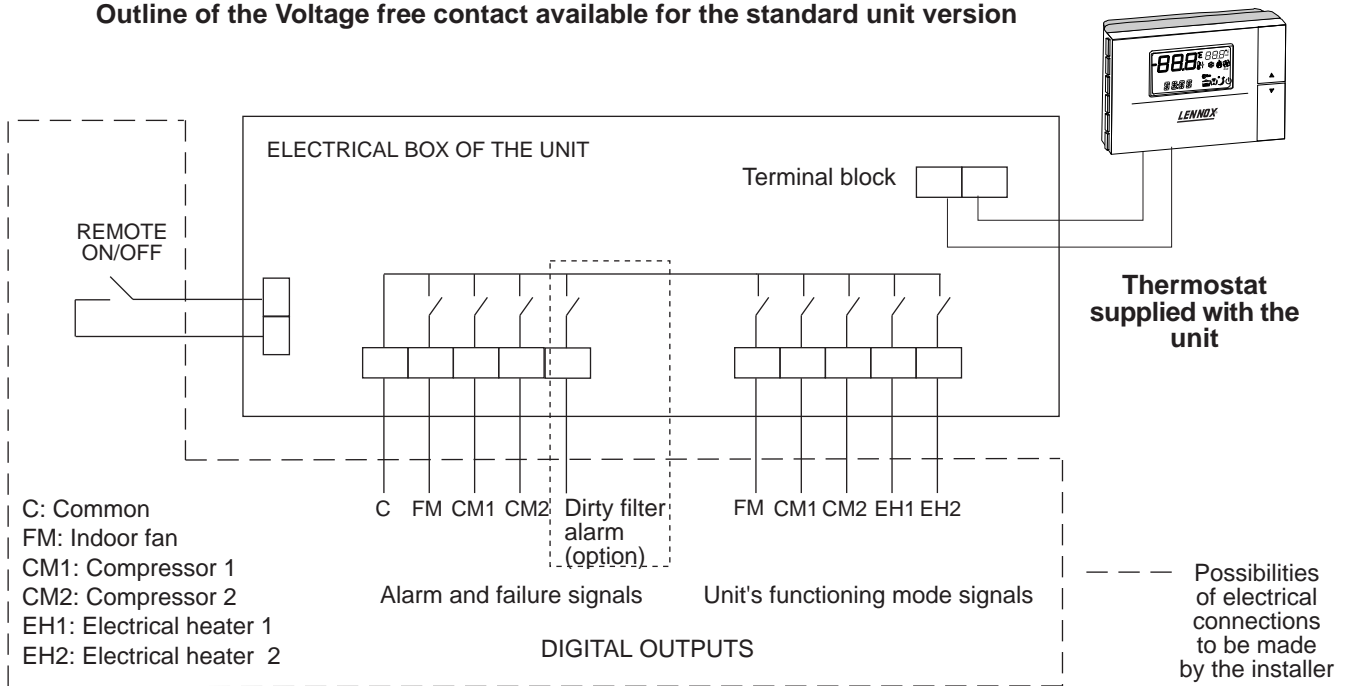

Outline of the Voltage free contact available for the VFC unit version

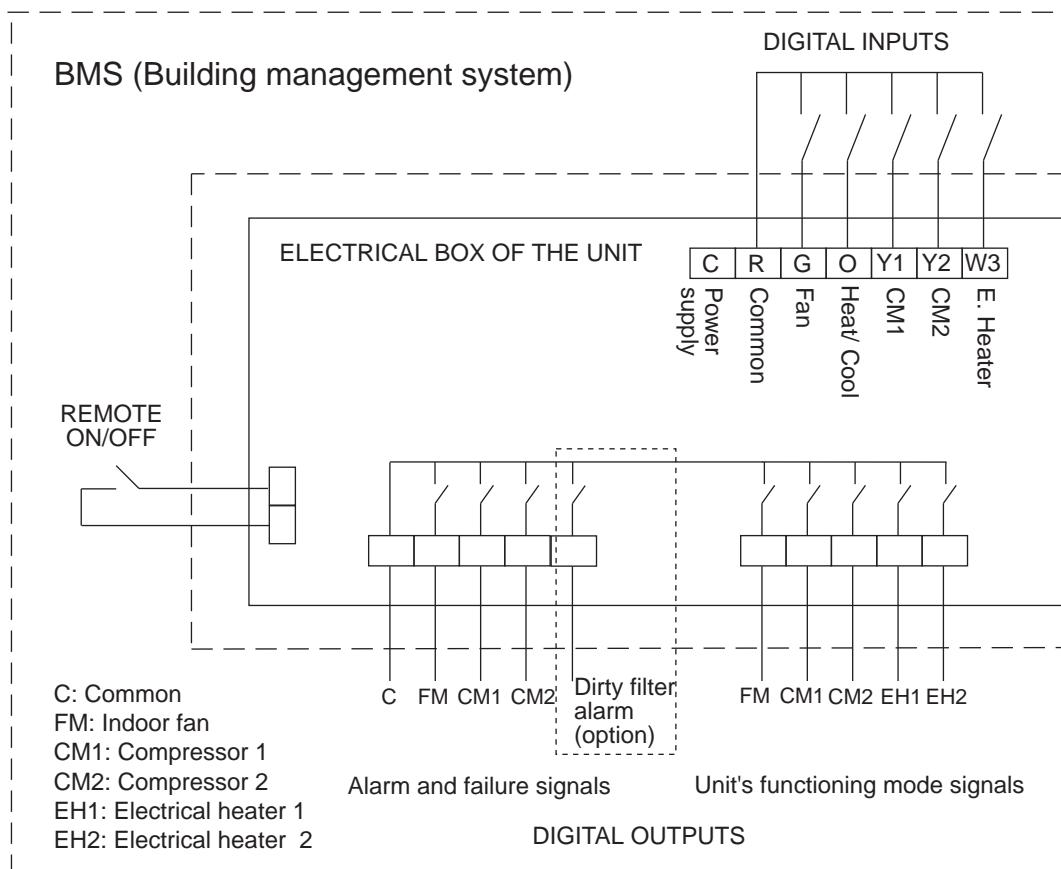

GENERAL DESCRIPTION

OPTIONS

OPTIONS	STANDARD VERSION	VFC VERSION	Remarks
Condensing pressure control ON/OFF	X	X	Crank case heater included in cooling only units
Proportional condensing pressure control	X	X	Crank case heater included in cooling only units.
Main switch only for 400V-III	X	X	
Return lock three phases	X	X	
"Soft starter" 400V-III	X	X	only for 400V-III units.
Hot gas bypass	X	X	Not available for 86D models.
Condenser coil guard	X	X	
Precoated coil	X	X	
Rubber dampers	X	X	
Kit low noise	X	X	Proportional CPC and compressor acoustic jacket included.
Service valves	X	X	
Refrigerant factory precharged	X	X	Service valves included.
Programmable thermostat	X	X	
Non-Programmable thermostat	STD	X	
Ambient remote sensor kit	X	X	
Duct remote sensor kit	X	X	
Electrical heater	X	X	Electrical heater is not available for heat pump double circuit units ("D") with thermostatic freecooling.
Hot water coil	X	X	Not available for 86D models.
Kit freecooling thermostatic without extract fan supplied with sensor incorporated in the thermostat	X	NO	Thermostatic freecooling supplied with sensor incorporated inside the thermostat. Double circuit heat pump units "D", can not include electrical heater.
Kit freecooling thermostatic with extract fan supplied with sensor incorporated in the thermostat	X	NO	Thermostatic freecooling supplied with sensor incorporated inside the thermostat. Double circuit heat pump units "D", can not include electrical heater.
Kit freecooling enthalpic without extract fan supplied with duct sensor	NO	X	Enthalpic freecooling supplies with duct sensor.
Kit freecooling enthalpic with extract fan supplied with duct sensor	NO	X	Enthalpic freecooling supplies with duct sensor.
Kit sensor incorporated at thermostat for freecooling	STD	X	Option for freecooling
Kit duct sensor for freecooling	X	STD	Option for freecooling
Kit ambient sensor for freecooling	X	X	Option for freecooling
Kit high static pressure indoor unit to 400 Pa	X	X	
Dirt filter indication	X	X	
Smoke detector	X	X	

STD: as standard
X: available optional
NO: not available

DENOMINATION

SET

INDOOR UNIT + OUTDOOR UNIT

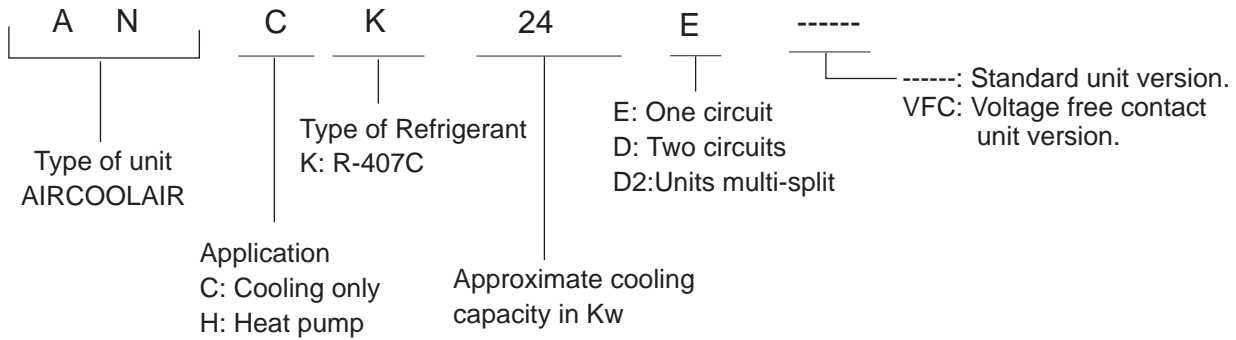

INDOOR UNIT

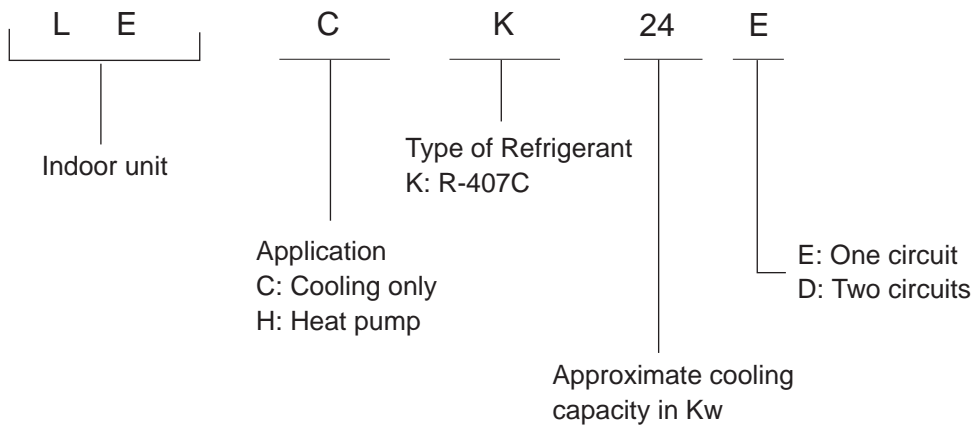

OUTDOOR UNIT

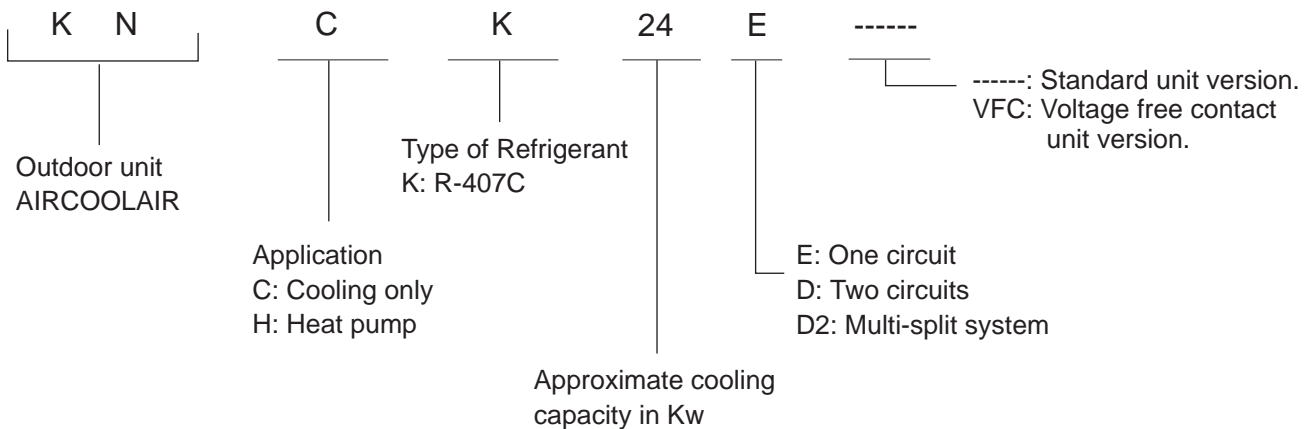

RANGE PRODUCT UNITS COOLING ONLY WITH REFRIGERANT R-407C

SET AND SPLIT SYSTEM

MODEL	OUTDOOR UNIT	INDOOR UNIT	V / Ph / 50 Hz	NOMINAL CAPACITY KW	NOMINAL CONSUMPTION KW
				COOLING	COOLING
ANCK 24E	KNCK 24E	LECK 24E	230V-400V+N/3Ph	21,30	8,70
ANCK 32E	KNCK 32E	LECK 32E	230V-400V+N/3Ph	27,50	11,70
ANCK 38E	KNCK 38E	LECK 38E	230V-400V+N/3Ph	35,50	14,50
ANCK 43E	KNCK 43E	LECK 43E	230V-400V+N/3Ph	40,00	17,10
ANCK 48D	KNCK 48D	LECK 48D	230V-400V+N/3Ph	42,20	17,60
ANCK 64D	KNCK 64D	LECK 64D	230V-400V+N/3Ph	55,00	23,40
ANCK 76D	KNCK 76D	LECK 76D	230V-400V+N/3Ph	71,00	29,00
ANCK 86D	KNCK 86D	LECK 86D	230V-400V+N/3Ph	80,00	34,20

INDOOR UNIT
LECK-E

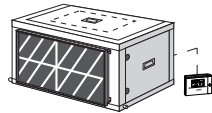

INDOOR UNIT
LECK-D

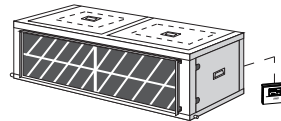

OUTDOOR UNIT
KNCK-E

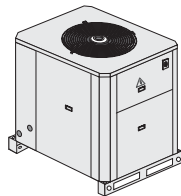

OUTDOOR UNIT
KNCK-D

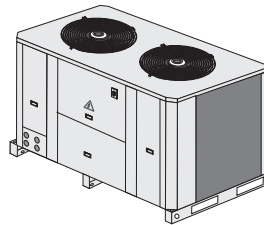

MULTI-SPLIT SYSTEM

MODEL	OUTDOOR UNIT	INDOOR UNIT	V / Ph / 50 Hz	NOMINAL CAPACITY KW	NOMINAL CONSUMPTION KW
				COOLING	COOLING
ANCK 48D2	KNCK 48D2	2 x LECK 24E	230V-400V+N/3Ph	42,20	17,60
ANCK 64D2	KNCK 64D2	2 x LECK 32E	230V-400V+N/3Ph	55,00	23,40
ANCK 76D2	KNCK 76D2	2 x LECK 38E	230V-400V+N/3Ph	71,00	29,00
ANCK 86D2	KNCK 86D2	2 x LECK 43E	230V-400V+N/3Ph	80,00	34,20

INDOOR UNIT LECK-E

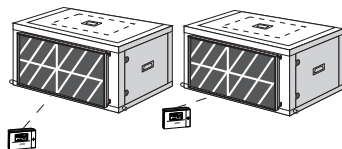

OUTDOOR UNIT
KNCK-D2

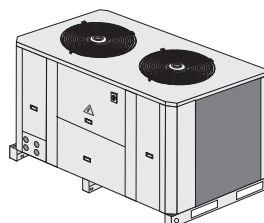

NOTE: The units at 230V-3Ph power supply are special. Ask for availability.

RANGE PRODUCT UNITS HEAT PUMP WITH REFRIGERANT R-407C

SET AND SPLIT SYSTEM

MODEL	OUTDOOR UNIT	INDOOR UNIT	V / Ph / 50 Hz	NOMINAL CAPACITY KW		NOMINAL CONSUMPTION KW	
				COOLING	H.PUMP	COOLING	H.PUMP
ANHK 24E	KNHK 24E	LEHK 24E	230V-400V+N/3Ph	21,30	22,30	8,70	7,70
ANHK 32E	KNHK 32E	LEHK 32E	230V-400V+N/3Ph	27,50	30,00	11,70	10,70
ANHK 38E	KNHK 38E	LEHK 38E	230V-400V+N/3Ph	35,50	37,00	14,50	12,70
ANHK 43E	KNHK 43E	LEHK 43E	230V-400V+N/3Ph	40,00	43,00	17,10	15,40
ANHK 48D	KNHK 48D	LEHK 48D	230V-400V+N/3Ph	42,20	44,60	17,60	15,90
ANHK 64D	KNHK 64D	LEHK 64D	230V-400V+N/3Ph	55,00	60,00	23,40	21,40
ANHK 76D	KNHK 76D	LEHK 76D	230V-400V+N/3Ph	71,00	74,00	29,00	25,40
ANHK 86D	KNHK 86D	LEHK 86D	230V-400V+N/3Ph	80,00	86,00	34,20	30,80

INDOOR UNIT
LEHK-E

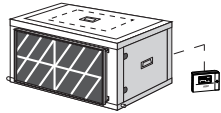

INDOOR UNIT
LEHK-D

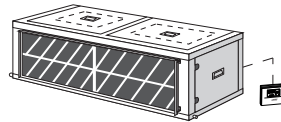

OUTDOOR UNIT
KNHK-E

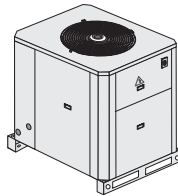

OUTDOOR UNIT
KNHK-D

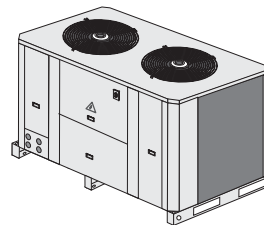

MULTI-SPLIT SYSTEM

MODEL	OUTDOOR UNIT	INDOOR UNIT	V / Ph / 50 Hz	NOMINAL CAPACITY KW		NOMINAL CONSUMPTION KW	
				COOLING	H.PUMP	COOLING	H.PUMP
ANHK 48D2	KNHK 48D2	2 x LEHK 24E	230V-400V+N/3Ph	42,20	44,60	17,60	15,90
ANHK 64D2	KNHK 64D2	2 x LEHK 32E	230V-400V+N/3Ph	55,00	60,00	23,40	21,40
ANHK 76D2	KNHK 76D2	2 x LEHK 38E	230V-400V+N/3Ph	71,00	74,00	29,00	25,40
ANHK 86D2	KNHK 86D2	2 x LEHK 43E	230V-400V+N/3Ph	80,00	86,00	34,20	30,80

INDOOR UNIT LEHK-E

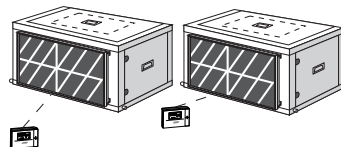

OUTDOOR UNIT
KNHK-D2

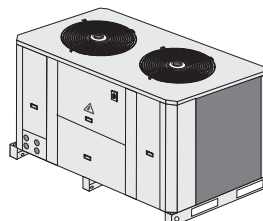

NOTE: The units at 230V-3Ph power supply are special. Ask for availability.

PHYSICAL DATA

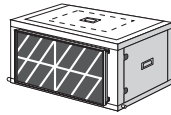

INDOOR UNIT

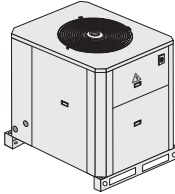

OUTDOOR UNIT

SET			ANCK/ANHK 24E	ANCK/ANHK 32E	ANCK/ANHK 38E	ANCK/ANHK 43E	
Cooling capacity	(*)	ANCK/ANHK Kw	21,30	27,50	35,50	40,00	
Heating capacity	(**)	ANHK Kw	22,30	30,00	37,00	43,00	
OUTDOOR UNIT			KNCK/KNHK 24E	KNCK/KNHK 32E	KNCK/KNHK 38E	KNCK/KNHK 43E	
COMPRESSOR	Nr / Type		1 / Scroll	1 / Scroll	1 / Scroll	1 / Scroll	
FAN	Air flow		m ³ /h.	6300	11500	11000	10500
NET WEIGHT	KNCK		Kg	225	250	270	300
	KNHK		Kg	230	255	275	305
DIMENSIONS							
	Height		mm.	1375	1375	1375	1375
	Width		mm.	1195	980	980	980
	Depth		mm.	660	1195	1195	1195
REFRIGERANT CONNECTION							
	Liquid			5/8"	5/8"	3/4"	7/8"
	Gas			1-1/8"	1-1/8"	1-3/8"	1-5/8"
INDOOR UNIT			LECK/LEHK 24E	LECK/LEHK 32E	LECK/LEHK 38E	LECK/LEHK 43E	
FAN	Max air flow		m ³ /h.	5100	6000	7300	8750
	Min air flow		m ³ /h.	3900	4750	5800	6500
	Max available pressure		(1) Pa	195	220	240	290
NET WEIGHT			Kg	105	110	145	150
DIMENSIONS							
	Height		mm.	665	665	665	665
	Width		mm.	1285	1285	1410	1570
	Depth		mm.	803	803	803	803
REFRIGERANT CONNECTION							
	Liquid			5/8"	5/8"	3/4"	7/8"
	Gas			1-1/8"	1-1/8"	1-3/8"	1-5/8"

(1) With minimum air flow admissible.

DB.- Dry bulb temperature
WB.- Wet bulb temperature

(*) Air intake temperature in the indoor exchanger: 27°C DB/19 °C WB

(*) Air intake temperature in the outdoor exchanger: 35 °C DB

(**) Air intake temperature in the indoor exchanger: 20°C DB

(**) Air intake temperature in the outdoor exchanger: 7°C DB / 6 °C WB

PHYSICAL DATA

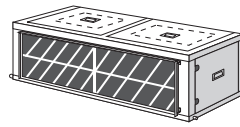

INDOOR UNIT

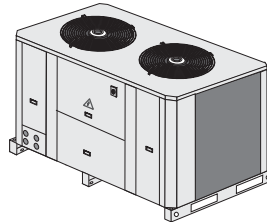

OUTDOOR UNIT

SET			ANCK/ANHK 48D	ANCK/ANHK 64D	ANCK/ANHK 76D	ANCK/ANHK 86D
Cooling capacity	(*)	ANCK/ANHK Kw	42,20	55,00	71,00	80,00
Heating capacity	(**)	ANHK Kw	44,60	60,00	74,00	86,00
OUTDOOR UNIT			KNCK/KNHK 48D	KNCK/KNHK 64D	KNCK/KNHK 76D	KNCK/KNHK 86D
COMPRESSOR	Nr / Type		2 / Scroll	2 / Scroll	2 / Scroll	2 / Scroll
FAN						
Air flow		m ³ /h.	19000	23000	22000	21000
NET WEIGHT						
	KNCK	Kg	485	490	530	590
	KNHK	Kg	495	500	545	605
DIMENSIONS						
Height		mm.	1375	1375	1375	1375
Width		mm.	1960	1960	1960	1960
Depth		mm.	1195	1195	1195	1195
REFRIGERANT CONNECTION						
Liquid			2 x 5/8"	2 x 5/8"	2 x 3/4"	2 x 7/8"
Gas			2 x 1-1/8"	2 x 1-1/8"	2 x 1-3/8"	2 x 1-5/8"
INDOOR UNIT			LECK/LEHK 48D	LECK/LEHK 64D	LECK/LEHK 76D	LECK/LEHK 86D
FAN						
Max air flow		m ³ /h.	10200	12000	14600	17500
Min air flow		m ³ /h.	7800	9500	11600	13000
Max available pressure	(1)	Pa	195	220	240	270
NET WEIGHT		Kg	220	240	265	270
DIMENSIONS						
Height		mm.	665	665	665	665
Width		mm.	2340	2340	2590	3140
Depth		mm.	803	803	803	803
REFRIGERANT CONNECTION						
Liquid			2 x 5/8"	2 x 5/8"	2 x 3/4"	2 x 7/8"
Gas			2 x 1-1/8"	2 x 1-1/8"	2 x 1-3/8"	2 x 1-5/8"

(1) With minimum air flow admissible.

DB.- Dry bulb temperature
WB.- Wet bulb temperature

(*) Air intake temperature in the indoor exchanger: 27°C DB/19 °C WB

(*) Air intake temperature in the outdoor exchanger: 35 °C DB

(**) Air intake temperature in the indoor exchanger: 20°C DB

(**) Air intake temperature in the outdoor exchanger: 7°C DB / 6 °C WB

PHYSICAL DATA

MULTI-SPLIT SYSTEM

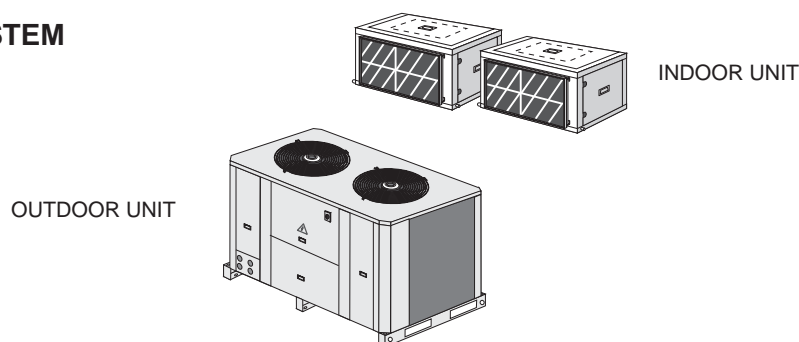

SET			ANCK/ANHK 48D2	ANCK/ANHK 64D2	ANCK/ANHK 76D2	ANCK/ANHK 86D2
Cooling capacity	(*) ANCK/ANHK	Kw	42,20	55,00	71,00	80,00
Heating capacity	(**) ANHK	Kw	44,60	60,00	74,00	86,00
OUTDOOR UNIT			KNCK/KNHK 48D2	KNCK/KNHK 64D2	KNCK/KNHK 76D2	KNCK/KNHK 86D2
COMPRESSOR	Nr / Type		2 / Scroll	2 / Scroll	2 / Scroll	2 / Scroll
FAN	Air flow	m ³ /h.	19000	23000	22000	21000
NET WEIGHT	KNCK	Kg	485	490	530	590
	KNHK	Kg	495	500	545	605
DIMENSIONS						
	Height	mm.	1375	1375	1375	1375
	Width	mm.	1960	1960	1960	1960
	Depth	mm.	1195	1195	1195	1195
REFRIGERANT CONNECTION						
	Liquid		2 x 5/8"	2 x 5/8"	2 x 3/4"	2 x 7/8"
	Gas		2 x 1-1/8"	2 x 1-1/8"	2 x 1-3/8"	2 x 1-5/8"
INDOOR UNIT			2 x LECK 2 x LEHK 24E	2 x LECK 2 x LEHK 32E	2 x LECK 2 x LEHK 38E	2 x LECK 2 x LEHK 43E
FAN	Max air flow	m ³ /h.	2 x 5100	2 x 6000	2 x 7300	2 x 8750
	Min air flow	m ³ /h.	2 x 3900	2 x 4750	2 x 5800	2 x 6500
	Max available pressure	(1) Pa	2 x 195	2 x 220	2 x 240	2 x 290
NET WEIGHT		Kg	2 x 105	2 x 110	2 x 145	2x 280
DIMENSIONS						
	Height	mm.	2 x 665	2 x 665	2 x 665	2 x 665
	Width	mm.	2 x 1285	2 x 1285	2 x 1410	2 x 1570
	Depth	mm.	2 x 803	2 x 803	2 x 803	2 x 803
REFRIGERANT CONNECTION						
	Liquid		2 x 5/8"	2 x 5/8"	2 x 3/4"	2 x 7/8"
	Gas		2 x 1-1/8"	2 x 1-1/8"	2 x 1-3/8"	2 x 1-5/8"

(1) With minimum air flow admissible.

DB.- Dry bulb temperature
WB.- Wet bulb temperature

(*) Air intake temperature in the indoor exchanger: 27°C DB/19 °C WB

(*) Air intake temperature in the outdoor exchanger: 35 °C DB

(**) Air intake temperature in the indoor exchanger: 20°C DB

(**) Air intake temperature in the outdoor exchanger: 7°C DB / 6 °C WB

ELECTRICAL DATA

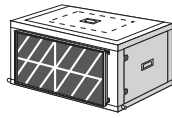

INDOOR UNIT

R-407C

OUTDOOR UNIT

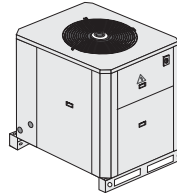

UNIT MODELS		ANCK 24E ANHK 24E	ANCK 32E ANHK 32E	ANCK 38E ANHK 38E	ANCK 43E ANHK 43E
Voltage	V/f (50 Hz)	230V-400V+N/ 3Ph			
Maximum absorbed power	Kw	10,3	15,6	18,4	22,4
Maximum current	A	30,2/18,1	46,2/28,1	55,8/32,7	67,1/39,5
Start up current	A	171,9/103,1	233,7/134,1	288,7/165,1	343,8/198,5

UNIT MODELS		KNCK 24E KNHK 24E	KNCK 32E KNHK 32E	KNCK 38E KNHK 38E	KNCK 43E KNHK 43E
Voltage	V/f (50 Hz)	230V-400V+N/ 3Ph			
Maximum absorbed power	Kw	8,9	13,8	16,4	19,9
Maximum current	A	25,9/15,6	40,0/24,5	49,6/29,1	56,8/33,5
Start up current	A	167,6/100,6	227,5/130,5	282,5/161,5	333,5/192,5

UNIT MODELS		LECK 24E LEHK 24E	LECK 32E LEHK 32E	LECK 38E LEHK 38E	LECK 43E LEHK 43E
Voltage	V/f (50 Hz)	230V-400V/ 3Ph			
Maximum absorbed power	Kw	1,4	1,8	2	2,5
Maximum current	A	4,3/2,5	6,2/3,6	6,2/3,6	10,3/6,0
Start up current	A	20,4/11,8	32,5/18,8	32,5/18,8	65,5/38

ELECTRICAL DATA

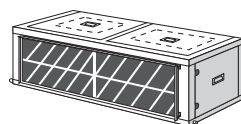

INDOOR UNIT

R-407C

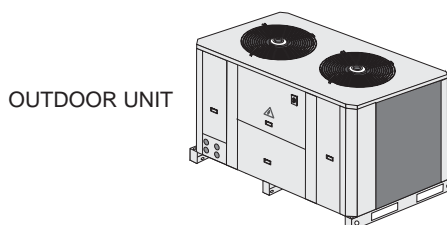

OUTDOOR UNIT

UNIT MODELS		ANCK 48D ANHK 48D	ANCK 64D ANHK 64D	ANCK 76D ANHK 76D	ANCK 86D ANHK 86D
Voltage	V/f (50 Hz)	230V-400V+N/ 3Ph			
Maximum absorbed power	Kw	21,5	31,2	36,8	44,8
Maximum current	A	63,4/39,1	92,5/56,2	111,7/65,4	134,2/78,9
Start up current	A	205,1	280,0	344,6	410,6
		124,1	162,2	197,8	237,9

UNIT MODELS		KNCK 48D KNHK 48D	KNCK 64D KNHK 64D	KNCK 76D KNHK 76D	KNCK 86D KNHK 86D
Voltage	V/f (50 Hz)	230V-400V+N/ 3Ph			
Maximum absorbed power	Kw	18,7	27,6	32,8	39,8
Maximum current	A	54,6/34,0	80,0/49,0	99,2/58,2	113,6/67,0
Start up current	A	196,3	267,5	332,1	390,0
		119,0	155,0	190,6	226,0

UNIT MODELS		LECK 48D LEHK 48D	LECK 64D LEHK 64D	LECK 76D LEHK 76D	LECK 86D LEHK 86D
Voltage	V/f (50 Hz)	230V-400V+N/ 3Ph			
Maximum absorbed power	Kw	2,8	3,6	4	5
Maximum current	A	8,8/5,1	12,5/7,2	12,5/7,2	20,6/11,9
Start up current	A	46,7/27	64,7/37,4	64,7/37,4	131/76

ELECTRICAL DATA

MULTI-SPLIT SYSTEM

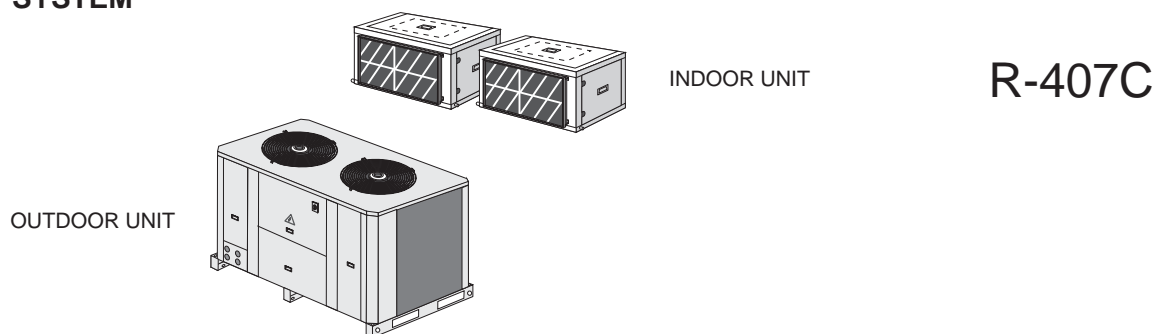

UNIT MODELS		ANCK 48D2 ANHK 48D2	ANCK 64D2 ANHK 64D2	ANCK 76D2 ANHK 76D2	ANCK 86D2 ANHK 86D2
Voltage	V/f (50 Hz)	230V-400V+N/ 3Ph			
Maximum absorbed power	Kw	21,5	31,2	36,8	44,8
Maximum current	A	63,4/39,1	92,5/56,2	111,7/65,4	134,2/78,9
Start up current	A	205,1	280,0	344,6	410,6
		124,1	162,2	197,8	237,9

UNIT MODELS		KNCK 48D2 KNHK 48D2	KNCK 64D2 KNHK 64D2	KNCK 76D2 KNHK 76D2	KNCK 86D2 KNHK 86D2
Voltage	V/f (50 Hz)	230V-400V+N/ 3Ph			
Maximum absorbed power	Kw	18,7	27,6	32,8	39,8
Maximum current	A	54,6/34,0	80,0/49,0	99,2/58,2	113,6/67,0
Start up current	A	196,3	267,5	332,1	390,0
		119,0	155,0	190,6	226,0

UNIT MODELS		2 x LECK 2 x LEHK 24E	2 x LECK 2 x LEHK 32E	2 x LECK 2 x LEHK 38E	2 x LECK 2 x LEHK 43E
Voltage	V/f (50 Hz)	230V-400V/ 3Ph			
Maximum absorbed power	Kw	2,8	3,6	4	5
Maximum current	A	8,8/5,1	12,5/7,2	12,5/7,2	20,6/11,9
Start up current	A	46,7/27	64,7/37,4	64,7/37,4	131/76

FAN PERFORMANCES

STANDARD INDOOR FAN PERFORMANCES

		24E					32E						
AIR FLOW		R.P.M.	M ³ /H	3900	4300	4700	5100	R.P.M.	M ³ /H	4750	5250	5750	6000
PULLEY POSITION	PULLEY CLOSED	890	195*	165*	130*	85*		1010	220*	175*	115*	70*	
	1 TURN	840	150*	125*	90*	50*		955	165*	115*	50*	0*	
	2 TURNS	790	115*	90*	55*	15*		900	125*	65*	0*	—	
	3 TURNS	740	80*	60*	20*	—		845	80*	25*	—	—	

		38E					43E						
AIR FLOW		R.P.M.	M ³ /H	5800	6400	7000	7300	R.P.M.	M ³ /H	6500	7250	8000	8750
PULLEY POSITION	PULLEY CLOSED	1010	240*	200*	●	●		1075	290*	245*	185*	135*	
	1 TURN	955	190*	150*	100*	●		1010	235*	185*	125*	95*	
	2 TURNS	900	150*	110*	65*	40*		940	180*	125*	60*	0*	
	3 TURNS	845	105*	60*	15*	0*		870	140*	85*	20*	—	

		48D					64D						
AIR FLOW		R.P.M.	M ³ /H	7800	8600	9400	10200	R.P.M.	M ³ /H	9500	10500	11500	12000
PULLEY POSITION	PULLEY CLOSED	890	195*	165*	130*	85*		1010	220*	175*	115*	70*	
	1 TURN	840	150*	125*	90*	50*		955	165*	115*	50*	0*	
	2 TURNS	790	115*	90*	55*	15*		900	125*	65*	0*	—	
	3 TURNS	740	80*	60*	20*	—		845	80*	25*	—	—	

		76D					86D						
AIR FLOW		R.P.M.	M ³ /H	11600	12800	14000	14600	R.P.M.	M ³ /H	13000	14500	16000	17500
PULLEY POSITION	PULLEY CLOSED	1010	240*	200*	●	●		1055	270*	225*	165*	115*	
	1 TURN	955	190*	150*	100*	●		1010	235*	185*	125*	95*	
	2 TURNS	900	150*	110*	65*	40*		965	195*	145*	85*	35*	
	3 TURNS	845	105*	60*	15*	0*		920	160*	110*	45*	—	

- (*) AVAILABLE STATIC PRESSURE Pa
 (●) WRONG STATUS ON ACCOUNT OF MOTOR POWER LIMIT.

NOTE: The unit leaves factory with pulley two turns opened.

FAN PERFORMANCES

INDOOR FAN PERFORMANCES WITH KIT HIGH STATIC PRESSURE TO 400 Pa (OPTION)

		24E					32E						
AIR FLOW		R.P.M.	M ³ /H	3900	4300	4700	5100	R.P.M.	M ³ /H	4750	5250	5750	6000
PULLEY POSITION	PULLEY CLOSED	1140	405*	385*	360*	●	1200	400*	365*	300*	270*		
	1 TURN	1070	340*	315*	290*	●	1125	330*	290*	220*	190*		
	2 TURNS	995	275*	250*	205*	195*	1050	265*	225*	145*	110*		
	3 TURNS	920	215*	190*	160*	130*	970	205*	160*	80*	40*		

		38E					43E						
AIR FLOW		R.P.M.	M ³ /H	5800	6400	7000	7300	R.P.M.	M ³ /H	6500	7250	8000	8750
PULLEY POSITION	PULLEY CLOSED	1200	450*	425*	385*	●	1200	410*	390*	325*	●		
	1 TURN	1125	380*	360*	310*	●	1125	340*	315*	240*	205*		
	2 TURNS	1050	310*	280*	220*	205*	1050	270*	245*	165*	130*		
	3 TURNS	970	245*	215*	155*	140*	970	215*	185*	105*	60*		

		48D					64D						
AIR FLOW		R.P.M.	M ³ /H	7800	8600	9400	10200	R.P.M.	M ³ /H	9500	10500	11500	12000
PULLEY POSITION	PULLEY CLOSED	1140	405*	385*	360*	●	1200	400*	365*	300*	●		
	1 TURN	1070	340*	315*	290*	●	1125	330*	290*	220*	190*		
	2 TURNS	995	275*	250*	205*	195*	1050	265*	225*	145*	110*		
	3 TURNS	920	215*	190*	160*	130*	970	205*	160*	80*	40*		

		76D					86D						
AIR FLOW		R.P.M.	M ³ /H	11600	12800	14000	14600	R.P.M.	M ³ /H	13000	14500	16000	17500
PULLEY POSITION	PULLEY CLOSED	1200	450*	425*	●	●	1200	410*	390*	●	●		
	1 TURN	1125	380*	360*	310*	●	1150	365*	345*	265*	●		
	2 TURNS	1050	310*	280*	220*	●	1100	315*	295*	215*	●		
	3 TURNS	970	245*	215*	155*	140*	1050	270*	245*	165*	130*		

(*) AVAILABLE STATIC PRESSURE Pa

(●) WRONG STATUS ON ACCOUNT OF MOTOR POWER LIMIT.

NOTE: The unit leaves factory with pulley two turns opened.

TECHNICAL DATA

SOUND PRESSURE / SOUND POWER LEVELS FOR INDOOR UNIT

UNIT MODELS		LECK 24E LEHK 24E	LECK 32E LEHK 32E	LECK 38E LEHK 38E	LECK 43E LEHK 43E
Sound pressure level (Lp) (1)	dB(A)	59	60	61	62
Sound power level (Lw)	dB(A)	81	85	86	87

UNIT MODELS		LECK 48D LEHK 48D	LECK 64D LEHK 64D	LECK 76D LEHK 76D	LECK 86D LEHK 86D
Sound pressure level (Lp) (1)	dB(A)	59	61	62	63
Sound power level (Lw)	dB(A)	84	88	89	90

(1) Sound pressure level estimated and radiated by indoor fan to the room with normal absorption, measured 2m from the indoor discharge and the unit installed with intake and discharge ducts according with the unit size.

SOUND PRESSURE / SOUND POWER LEVELS FOR OUTDOOR UNIT

KNCK/ KNHK	Spectrum per octave band (dB(A))								Sound power dB(A)	Sound pressure at 10m. (dB(A))	
	63 Hz	125 Hz	250 Hz	500 Hz	1000 Hz	2000 Hz	4000 Hz	8000 Hz			
24	(1)	77,6	64,8	61,2	70,4	68,8	70,5	66,3	58,5	75,3	47,3
	(2)	77,6	64,8	61,1	68,2	65,5	66,1	62,4	58,1	71,8	43,8
32	(1)	78,1	78,7	70,8	72,8	76,5	75,7	67,7	62,4	80,6	52,6
	(2)	78,1	75,4	67,4	72,5	71,7	72,1	65,0	57,6	77,1	49,1
38	(1)	78,1	78,5	70,6	73,6	75,6	76,5	71,6	62,5	81,1	53,1
	(2)	78,1	75,4	67,4	70,8	71,6	72,9	68,8	59,2	77,6	49,6
43	(1)	78,1	78,6	70,8	75,9	76,6	78,9	71,6	62,8	82,8	54,8
	(2)	78,1	75,4	67,5	72,8	71,7	74,2	67,4	58,4	78,3	50,3
48	(1)	84,7	71,9	67,9	74,1	72,5	73,8	69,5	57,0	78,7	50,7
	(2)	84,7	71,9	67,9	72,3	69,9	69,8	66,1	56,0	75,7	47,7
64	(1)	81,1	81,5	73,6	77,9	78,6	78,8	71,3	64,3	83,6	55,6
	(2)	81,1	78,4	70,4	75,5	74,7	75,1	68,0	60,3	80,1	52,1
76	(1)	81,1	81,5	73,6	76,7	78,6	79,5	74,6	64,3	84,1	56,1
	(2)	81,1	78,4	70,4	73,8	74,6	75,9	71,8	60,3	80,6	52,6
86	(1)	81,1	81,6	73,8	78,9	79,6	82,0	74,6	65,0	85,8	57,8
	(2)	81,1	78,4	70,5	75,8	74,7	77,2	70,4	60,3	81,3	53,3

(1) The above data shows noise levels **without** isolation for compressor

(2) The above data shows noise levels **with** isolation for compressor (optional)

Global sound power level measured in compliance with ISO standard 3744 and under Eurovent certification program

Sound pressure in dB(A) calculated at 10 m, in a free field on a reflecting surface, is given as a guide only and with a directivity of +/- 3 dBA.

Only the sound power spectrum and the global sound power value are used in determining pressure characteristics on site.

The data table above, are calculated for units operating on cooling or heating mode (with ambient temperatures higher than + 35 °C), and at maximum fan speed.

COOLING CAPACITIES

R-407C

SPLIT SYSTEM KNCK + LECK / KNHK+ LEHK
MULTI-SPLIT SYSTEM KNCK-D2 + 2 x LECK / KNHK - D2 + 2 x LEHK

MODEL 24E

MODEL 32E

AIR ENTRY TEMPERATURE INDOOR UNIT	CAPACITY IN KW	AIR ENTRY TEMPERATURE INTO THE OUTDOOR UNIT °C DRY BULB					AIR ENTRY TEMPERATURE INTO THE OUTDOOR UNIT °C DRY BULB				
		25°C	30°C	35°C	40°C	45°C	25°C	30°C	35°C	40°C	45°C
21°C DB	TOTAL	19,80	19,10	18,40	17,60	16,80	25,70	24,70	23,80	22,80	21,80
	SENSIBLE	15,50	15,10	14,80	14,40	14,00	19,90	19,40	19,00	18,50	18,00
	POWER INPUT	7,20	7,80	8,50	9,20	10,00	9,60	10,50	11,40	12,40	13,50
24°C DB	TOTAL	21,40	20,60	19,80	18,90	18,10	27,60	26,60	25,60	24,50	23,50
	SENSIBLE	16,60	16,30	15,90	15,60	15,20	21,30	20,90	20,40	20,00	19,50
	POWER INPUT	7,30	7,90	8,60	9,30	10,20	9,80	10,60	11,50	12,60	13,70
27°C DB	TOTAL	23,00	22,20	21,30	20,40	19,50	29,70	28,60	27,50	26,40	25,30
	SENSIBLE	17,80	17,40	17,10	16,70	16,30	22,80	22,30	21,80	21,40	20,90
	POWER INPUT	7,40	8,00	8,70	9,50	10,30	9,90	10,80	11,70	12,80	13,90
29°C DB	TOTAL	24,70	23,90	22,90	22,00	21,00	31,90	30,80	29,60	28,40	-----
	SENSIBLE	17,80	17,40	17,10	16,70	16,30	22,70	22,30	21,80	21,40	-----
	POWER INPUT	7,50	8,10	8,80	9,60	10,50	10,00	10,90	11,90	12,90	-----
32°C DB	TOTAL	26,60	25,70	24,70	23,70	22,60	34,30	33,10	31,90	30,60	-----
	SENSIBLE	18,80	18,50	18,10	17,80	17,40	24,10	23,60	23,20	22,70	-----
	POWER INPUT	7,60	8,20	9,00	9,70	10,60	10,20	11,10	12,10	13,20	-----

MODEL 38E

MODEL 43E

AIR ENTRY TEMPERATURE INDOOR UNIT	CAPACITY IN KW	AIR ENTRY TEMPERATURE INTO THE OUTDOOR UNIT °C DRY BULB					AIR ENTRY TEMPERATURE INTO THE OUTDOOR UNIT °C DRY BULB				
		25°C	30°C	35°C	40°C	45°C	25°C	30°C	35°C	40°C	45°C
21°C DB	TOTAL	33,30	32,00	30,80	29,40	28,00	37,40	36,00	34,60	33,00	31,40
	SENSIBLE	26,10	25,50	24,90	24,30	23,60	28,90	28,20	27,50	26,80	26,10
	POWER INPUT	11,80	12,90	14,00	15,20	16,50	14,00	15,20	16,50	17,90	19,40
24°C DB	TOTAL	35,70	34,40	33,00	31,60	30,10	40,20	38,70	37,20	35,60	33,90
	SENSIBLE	28,00	27,40	26,80	26,20	25,50	31,00	30,30	29,70	28,90	28,20
	POWER INPUT	12,10	13,10	14,20	15,50	16,80	14,20	15,40	16,80	18,20	19,80
27°C DB	TOTAL	38,40	37,00	35,50	34,00	32,40	43,20	41,60	40,00	38,30	-----
	SENSIBLE	29,90	29,30	28,70	28,10	27,40	33,10	32,40	31,70	31,00	-----
	POWER INPUT	12,30	13,30	14,50	15,80	17,10	14,50	15,70	17,10	18,60	-----
29°C DB	TOTAL	41,20	39,70	38,20	36,50	-----	46,40	44,80	43,00	41,20	-----
	SENSIBLE	29,90	29,30	28,60	28,00	-----	33,00	32,40	31,70	30,90	-----
	POWER INPUT	12,50	13,60	14,80	16,10	-----	14,80	16,00	17,40	18,90	-----
32°C DB	TOTAL	44,30	42,70	41,00	39,30	-----	49,90	48,10	46,20	44,30	-----
	SENSIBLE	31,60	31,00	30,40	29,80	-----	35,00	34,30	33,60	32,90	-----
	POWER INPUT	12,80	13,90	15,10	16,40	-----	15,10	16,40	17,80	19,33	-----

MODELS 48D / 48D2 (MULTI)

MODELS 64D / 64D2 (MULTI)

AIR ENTRY TEMPERATURE INDOOR UNIT	CAPACITY IN KW	AIR ENTRY TEMPERATURE INTO THE OUTDOOR UNIT °C DRY BULB					AIR ENTRY TEMPERATURE INTO THE OUTDOOR UNIT °C DRY BULB				
		25°C	30°C	35°C	40°C	45°C	25°C	30°C	35°C	40°C	45°C
21°C DB	TOTAL	39,30	37,90	36,40	34,90	33,20	51,30	49,50	47,50	45,60	43,50
	SENSIBLE	30,10	29,40	28,70	27,90	27,20	39,70	38,80	37,90	37,00	36,00
	POWER INPUT	14,70	15,90	17,20	18,60	20,20	19,30	20,90	22,80	24,80	27,00
24°C DB	TOTAL	42,30	40,80	39,20	37,50	35,80	55,20	53,20	51,20	49,10	46,90
	SENSIBLE	32,30	31,60	30,90	30,10	29,30	42,70	41,80	40,80	39,90	38,90
	POWER INPUT	14,90	16,10	17,40	18,80	20,40	19,50	21,20	23,10	25,10	27,40
27°C DB	TOTAL	45,50	43,90	42,20	40,40	38,60	59,30	57,20	55,00	52,80	50,50
	SENSIBLE	34,40	33,70	33,00	32,20	31,50	45,50	44,60	43,70	42,70	41,80
	POWER INPUT	15,10	16,30	17,60	19,10	20,70	19,80	21,50	23,40	25,50	27,80
29°C DB	TOTAL	49,00	47,30	45,40	43,50	41,50	63,80	61,60	59,30	56,90	-----
	SENSIBLE	34,40	33,70	33,00	32,20	31,40	45,50	44,60	43,60	42,70	-----
	POWER INPUT	15,30	16,50	17,80	19,40	21,00	20,10	21,80	23,80	25,90	-----
32°C DB	TOTAL	52,70	50,80	48,90	46,90	44,70	68,60	66,20	63,70	61,20	-----
	SENSIBLE	36,40	35,70	35,00	34,20	33,50	48,20	47,30	46,40	45,40	-----
	POWER INPUT	15,50	16,70	18,10	19,60	21,30	20,40	22,20	24,10	26,30	-----

Nominal capacities

DB - Dry Bulb
 WB - Wet Bulb

**SPLIT SYSTEM KNCK + LECK / KNHK+ LEHK
MULTI-SPLIT SYSTEM KNCK-D2 + 2 x LECK / KNHK - D2 + 2 x LEHK**

AIR ENTRY TEMPERATURE INDOOR UNIT	CAPACITY IN KW	MODELS 76D / 76D2 (MULTI)					MODELS 86D / 86D2 (MULTI)				
		AIR ENTRY TEMPERATURE INTO THE OUTDOOR UNIT °C DRY BULB					AIR ENTRY TEMPERATURE INTO THE OUTDOOR UNIT °C DRY BULB				
		25°C	30°C	35°C	40°C	45°C	25°C	30°C	35°C	40°C	45°C
21°C DB	TOTAL	66,60	64,10	61,50	58,80	55,90	74,80	72,10	69,20	66,10	62,90
	SENSIBLE	52,20	51,00	49,80	48,50	47,20	57,80	56,50	55,10	53,60	52,10
	POWER INPUT	23,70	25,70	28,00	30,50	33,10	28,00	30,40	33,00	35,80	38,80
15°C WB	TOTAL	71,50	68,80	66,10	63,20	60,20	80,40	77,50	74,40	71,10	67,70
	SENSIBLE	56,10	54,90	53,60	52,40	51,00	62,00	60,70	59,30	57,80	56,30
	POWER INPUT	24,10	26,20	28,50	31,00	33,70	28,40	30,90	33,60	36,50	39,50
24°C DB	TOTAL	76,70	73,90	71,00	68,00	64,80	86,40	83,30	80,00	76,50	-----
	SENSIBLE	59,80	58,60	57,40	56,10	54,80	66,10	64,80	63,40	61,90	-----
	POWER INPUT	24,60	26,70	29,00	31,60	34,30	29,00	31,50	34,20	37,10	-----
17°C WB	TOTAL	82,40	79,40	76,30	73,10	-----	92,90	89,50	86,00	82,40	-----
	SENSIBLE	59,70	58,50	57,30	56,00	-----	66,10	64,70	63,30	61,90	-----
	POWER INPUT	25,10	27,20	29,60	32,20	-----	29,60	32,10	34,90	37,90	-----
27°C DB	TOTAL	88,50	85,30	82,00	78,50	-----	99,80	96,20	92,50	88,60	-----
	SENSIBLE	63,30	62,10	60,90	59,60	-----	70,00	68,60	67,20	65,80	-----
	POWER INPUT	25,60	27,80	30,20	32,80	-----	30,20	32,80	35,60	38,70	-----
19°C WB	TOTAL	82,40	79,40	76,30	73,10	-----	92,90	89,50	86,00	82,40	-----
	SENSIBLE	59,70	58,50	57,30	56,00	-----	66,10	64,70	63,30	61,90	-----
	POWER INPUT	25,10	27,20	29,60	32,20	-----	29,60	32,10	34,90	37,90	-----
29°C DB	TOTAL	88,50	85,30	82,00	78,50	-----	99,80	96,20	92,50	88,60	-----
	SENSIBLE	63,30	62,10	60,90	59,60	-----	70,00	68,60	67,20	65,80	-----
	POWER INPUT	25,60	27,80	30,20	32,80	-----	30,20	32,80	35,60	38,70	-----
21°C WB	TOTAL	88,50	85,30	82,00	78,50	-----	99,80	96,20	92,50	88,60	-----
	SENSIBLE	63,30	62,10	60,90	59,60	-----	70,00	68,60	67,20	65,80	-----
	POWER INPUT	25,60	27,80	30,20	32,80	-----	30,20	32,80	35,60	38,70	-----
32°C DB	TOTAL	88,50	85,30	82,00	78,50	-----	99,80	96,20	92,50	88,60	-----
	SENSIBLE	63,30	62,10	60,90	59,60	-----	70,00	68,60	67,20	65,80	-----
	POWER INPUT	25,60	27,80	30,20	32,80	-----	30,20	32,80	35,60	38,70	-----
23°C WB	TOTAL	88,50	85,30	82,00	78,50	-----	99,80	96,20	92,50	88,60	-----
	SENSIBLE	63,30	62,10	60,90	59,60	-----	70,00	68,60	67,20	65,80	-----
	POWER INPUT	25,60	27,80	30,20	32,80	-----	30,20	32,80	35,60	38,70	-----

Nominal capacities

DB - Dry Bulb
WB - Wet Bulb

CALCULATION OF COOLING CAPACITY DEPENDING ON AIR FLOW

Data based on the following nominal indoor fan air flow:

MODELS	24E	32E	38E	43E	48D	64D	76D	86D
INDOOR AIR FLOW M ³ /H	4700	5750	7000	8000	9400	11500	14000	16000

CORRECTION COEFFICIENT TO FIX TO THE CAPACITY OF DIFFERENT INDOOR AIR FLOW .

MODELS 24E-32E-38E-43E 48D-64D-76D-86D					
	% NOMINAL AIR FLOW				
	70%	80%	90%	100%	110%
Total capacity	0,96	0,97	0,98	1	1,01
Sensible capacity	0,9	0,93	0,96	1	1,03
Power input	0,98	0,99	1	1	1,01

Data based on the following nominal outdoor fan air flow:

MODELS	24E	32E	38E	43E	48D 48D2	64D 64D2	76D 76D2	86D 86D2
OUTDOOR AIR FLOW M ³ /H	7050	6800	6650	8000	14100	13600	13300	16000

HEATING CAPACITIES

R-407C

**SPLIT SYSTEM KNHK + LEHK
MULTI-SPLIT SYSTEM KNHK - D2 + 2 x LEHK**

MODEL 24E

MODEL 32E

AIR ENTRY TEMPERATURE INDOOR UNIT	Kw	AIR ENTRY TEMPERATURE INTO THE OUTDOOR UNIT °C WET BULB							AIR ENTRY TEMPERATURE INTO THE OUTDOOR UNIT °C WET BULB						
		-10°C	-5°C	0°C	6°C	10°C	14°C	18°C	-10°C	-5°C	0°C	6°C	10°C	14°C	18°C
15°C DB	Total capacity	14,90	17,00	19,30	22,50	25,00	27,70	30,60	20,20	22,90	25,90	30,20	33,50	37,20	41,30
	Power input	6,10	6,40	6,70	7,10	7,50	7,90	8,40	8,40	8,80	9,20	9,90	10,40	11,00	11,70
18°C DB	Total capacity	14,90	17,00	19,20	22,40	24,80	27,40	30,30	20,20	22,80	25,90	30,10	33,30	37,00	41,00
	Power input	6,40	6,70	7,00	7,50	7,80	8,30	8,80	8,80	9,20	9,70	10,30	10,90	11,50	12,30
20°C DB	Total capacity	14,90	16,90	19,20	22,30	24,70	27,30	30,20	20,20	22,80	25,80	30,00	33,20	36,80	40,80
	Power input	6,60	6,90	7,20	7,70	8,10	8,50	9,00	9,10	9,50	10,00	10,70	11,20	11,90	12,70
24°C DB	Total capacity	14,90	16,90	19,10	22,10	24,40	27,00	29,80	20,20	22,90	25,80	29,90	33,10	36,60	----
	Power input	6,90	7,30	7,70	8,20	8,60	9,10	9,60	9,70	10,10	10,60	11,40	12,00	12,70	----
27°C DB	Total capacity	14,80	16,80	19,00	22,00	24,30	26,80	----	20,30	22,90	25,80	29,90	33,00	36,40	----
	Power input	7,30	7,60	8,00	8,60	9,00	9,50	----	10,10	10,60	11,20	12,00	12,60	13,30	----

MODEL 38E

MODEL 43E

AIR ENTRY TEMPERATURE INDOOR UNIT	Kw	AIR ENTRY TEMPERATURE INTO THE OUTDOOR UNIT °C WET BULB							AIR ENTRY TEMPERATURE INTO THE OUTDOOR UNIT °C WET BULB						
		-10°C	-5°C	0°C	6°C	10°C	14°C	18°C	-10°C	-5°C	0°C	6°C	10°C	14°C	18°C
15°C DB	Total capacity	24,50	28,00	31,90	37,30	41,50	46,10	51,30	28,70	32,70	37,20	43,40	48,10	53,30	59,20
	Power input	9,80	10,30	10,90	11,70	12,40	13,20	14,10	11,80	12,40	13,20	14,20	15,10	16,10	17,30
18°C DB	Total capacity	24,50	27,90	31,80	37,10	41,20	45,80	50,90	28,60	32,60	37,10	43,20	47,80	52,90	58,70
	Power input	10,30	10,80	11,40	12,30	13,00	13,80	14,70	12,30	13,00	13,80	14,90	15,80	16,80	18,10
20°C DB	Total capacity	24,40	27,90	31,70	37,00	41,00	45,50	50,60	28,60	32,60	37,00	43,00	47,60	52,70	58,30
	Power input	10,60	11,20	11,80	12,70	13,40	14,20	15,20	12,70	13,40	14,20	15,40	16,30	17,40	18,60
24°C DB	Total capacity	24,40	27,80	31,50	36,70	40,70	45,10	50,00	28,50	32,50	36,80	42,70	47,20	52,10	----
	Power input	11,30	11,90	12,60	13,50	14,30	15,10	16,20	13,50	14,30	15,10	16,30	17,30	18,40	----
27°C DB	Total capacity	24,30	27,70	31,40	36,50	40,40	44,70	----	28,50	32,40	36,60	42,50	46,90	----	----
	Power input	11,90	12,50	13,20	14,20	15,00	15,90	----	14,10	14,90	15,80	17,10	18,10	----	----

MODELS 48D / 48D2 (MULTI)

MODELS 64D / 64D2 (MULTI)

AIR ENTRY TEMPERATURE INDOOR UNIT	Kw	AIR ENTRY TEMPERATURE INTO THE OUTDOOR UNIT °C WET BULB							AIR ENTRY TEMPERATURE INTO THE OUTDOOR UNIT °C WET BULB						
		-10°C	-5°C	0°C	6°C	10°C	14°C	18°C	-10°C	-5°C	0°C	6°C	10°C	14°C	18°C
15°C DB	Total capacity	29,80	33,90	38,60	44,90	49,80	55,20	61,20	40,30	45,70	51,80	60,40	67,00	74,40	82,50
	Power input	12,60	13,20	13,90	14,80	15,50	16,30	17,30	16,80	17,60	18,40	19,70	20,80	22,00	23,50
18°C DB	Total capacity	29,80	33,90	38,40	44,70	49,50	54,80	60,70	40,30	45,70	51,70	60,20	66,70	73,90	82,00
	Power input	13,20	13,80	14,50	15,40	16,20	17,10	18,10	17,60	18,40	19,30	20,70	21,80	23,10	24,60
20°C DB	Total capacity	29,80	33,80	38,40	44,60	49,30	54,50	60,30	40,40	45,70	51,70	60,00	66,50	73,70	81,60
	Power input	13,60	14,20	14,90	15,90	16,70	17,60	18,60	18,20	19,00	20,00	21,40	22,50	23,80	25,40
24°C DB	Total capacity	29,80	33,80	38,20	44,30	48,90	54,00	59,70	40,50	45,70	51,60	59,80	66,10	73,20	----
	Power input	14,40	15,00	15,80	16,90	17,70	18,60	19,80	19,30	20,20	21,30	22,80	24,00	25,40	----
27°C DB	Total capacity	29,70	33,70	38,10	44,10	48,60	53,60	----	40,60	45,80	51,60	59,70	65,90	72,80	----
	Power input	15,00	15,70	16,50	17,60	18,50	19,50	----	20,20	21,20	22,30	23,90	25,20	26,70	----

Nominal capacities

DB - Dry Bulb
WB - Wet Bulb

HEATING CAPACITIES

R-407C

SPLIT SYSTEM KNHK + LEHK
MULTI-SPLIT SYSTEM KNHK - D2 + 2 x LEHK

MODELS 76D / 76D2 (MULTI)

MODELS 86D / 86D2 (MULTI)

AIR ENTRY TEMPERATURE INDOOR UNIT	Kw	AIR ENTRY TEMPERATURE INTO THE OUTDOOR UNIT °C WET BULB							AIR ENTRY TEMPERATURE INTO THE OUTDOOR UNIT °C WET BULB						
		-10°C	-5°C	0°C	6°C	10°C	14°C	18°C	-10°C	-5°C	0°C	6°C	10°C	14°C	18°C
15°C DB	Total capacity	49,00	56,00	63,90	74,70	83,00	92,30	102,6	57,40	65,50	74,40	86,80	96,20	106,6	118,3
	Power input	19,70	20,70	21,80	23,50	24,80	26,30	28,20	23,60	24,90	26,30	28,50	30,20	32,20	34,60
18°C DB	Total capacity	48,90	55,90	63,60	74,30	82,40	91,60	101,8	57,30	65,30	74,20	86,30	95,60	105,9	117,3
	Power input	20,60	21,70	22,90	24,60	26,00	27,60	29,50	24,70	26,00	27,60	29,80	31,60	33,70	36,10
20°C DB	Total capacity	48,90	55,80	63,40	74,00	82,10	91,10	101,2	57,20	65,20	74,00	86,00	95,20	105,3	116,7
	Power input	21,30	22,40	23,60	25,40	26,80	28,50	30,40	25,50	26,90	28,50	30,80	32,60	34,70	37,20
24°C DB	Total capacity	48,70	55,60	63,10	73,50	81,40	90,20	100,0	57,10	64,90	73,60	85,40	94,30	104,3	-----
	Power input	22,70	23,80	25,20	27,10	28,50	30,30	32,30	27,00	28,60	30,30	32,70	34,60	36,90	-----
27°C DB	Total capacity	48,60	55,40	62,90	73,10	80,80	89,50	-----	56,90	64,70	73,30	84,90	93,70	-----	-----
	Power input	23,70	25,00	26,40	28,30	29,90	31,70	-----	28,20	29,90	31,70	34,20	36,20	-----	-----

Nominal capacities

DB - Dry Bulb
WB - Wet Bulb

CALCULATION OF HEATING CAPACITY DEPENDING ON AIR FLOW

Data based on the following nominal indoor fan air flow:

MODELS	24E	32E	38E	43E	48D	64D	76D	86D
INDOOR AIR FLOW M ³ /H	4700	5750	7000	8000	9400	11500	14000	16000

CORRECTION COEFFICIENT TO FIX TO THE CAPACITY OF DIFFERENT INDOOR AIR FLOW

MODELS 24E-32E-38E-43E 48D-64D-76D-86D					
	% NOMINAL AIR FLOW				
	70%	80%	90%	100%	110%
Total capacity	0,96	0,97	0,98	1	1,01
Sensible capacity	0,9	0,93	0,96	1	1,03
Power input	0,98	0,99	1	1	1,01

Data based on the following nominal outdoor fan air flow:

MODELS	24E	32E	38E	43E	48D 48D2	64D 64D2	76D 76D2	86D 86D2
OUTDOOR AIR FLOW M ³ /H	7050	6800	6650	8000	14100	13600	13300	16000

INDOOR SPLIT UNITS DIMENSIONS

MODELS LECK/LEHK 24E-32E

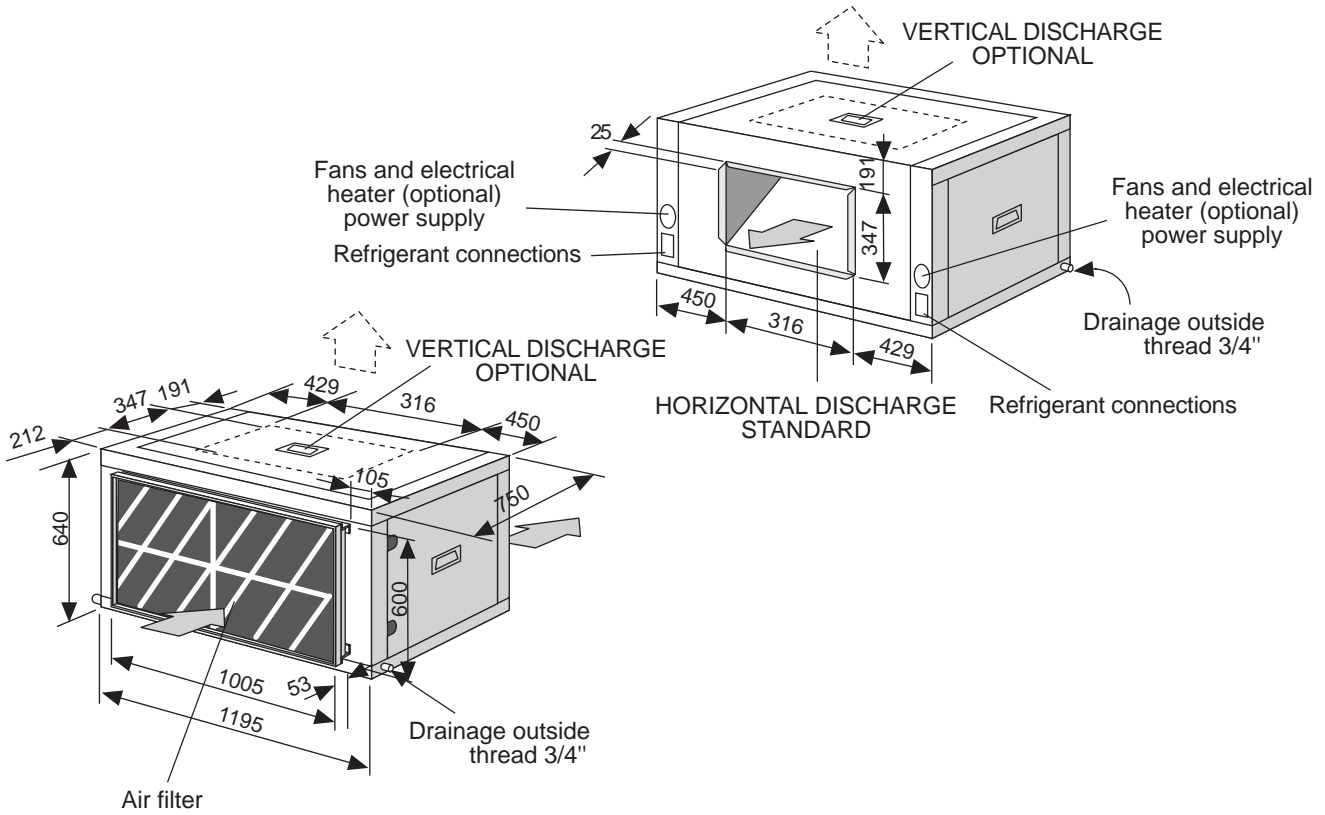

MODEL LECK/LEHK 38E

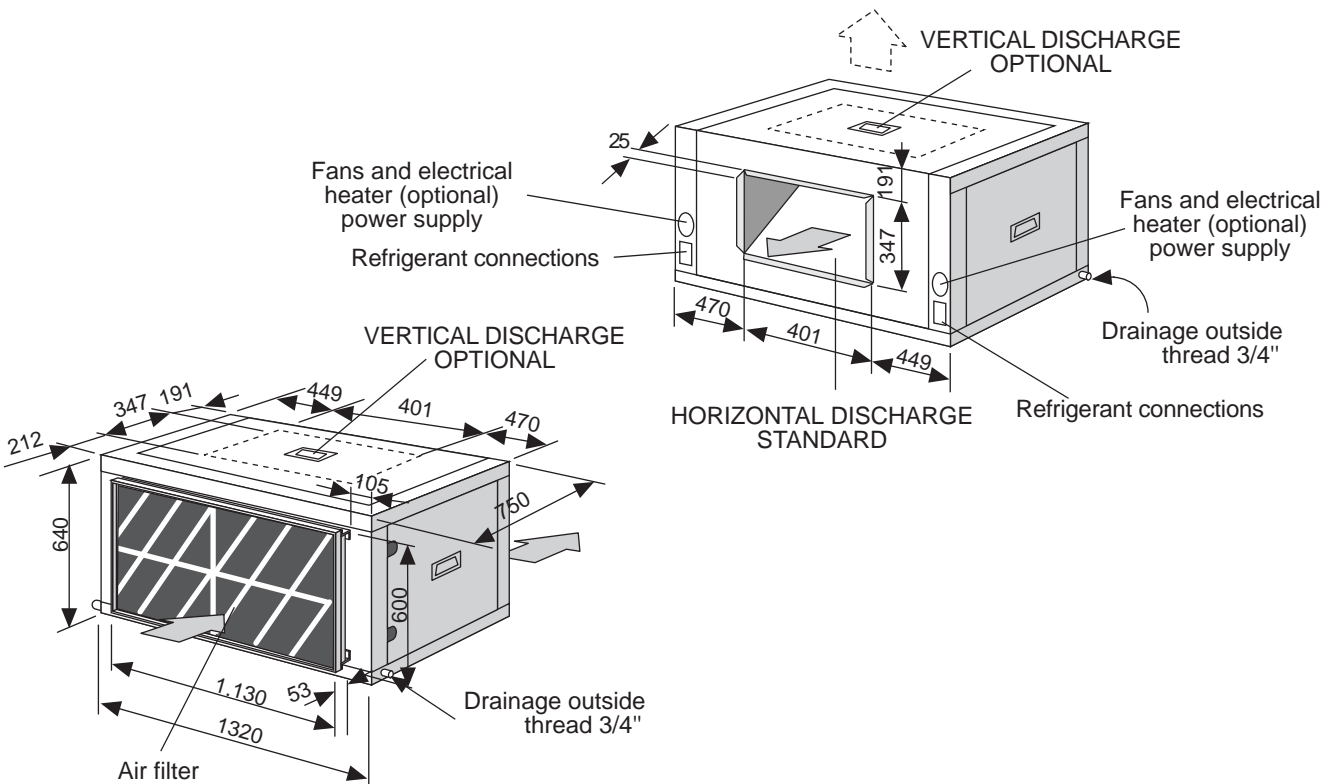

INDOOR SPLIT UNITS DIMENSIONS

MODELS LECK/LEHK 43E

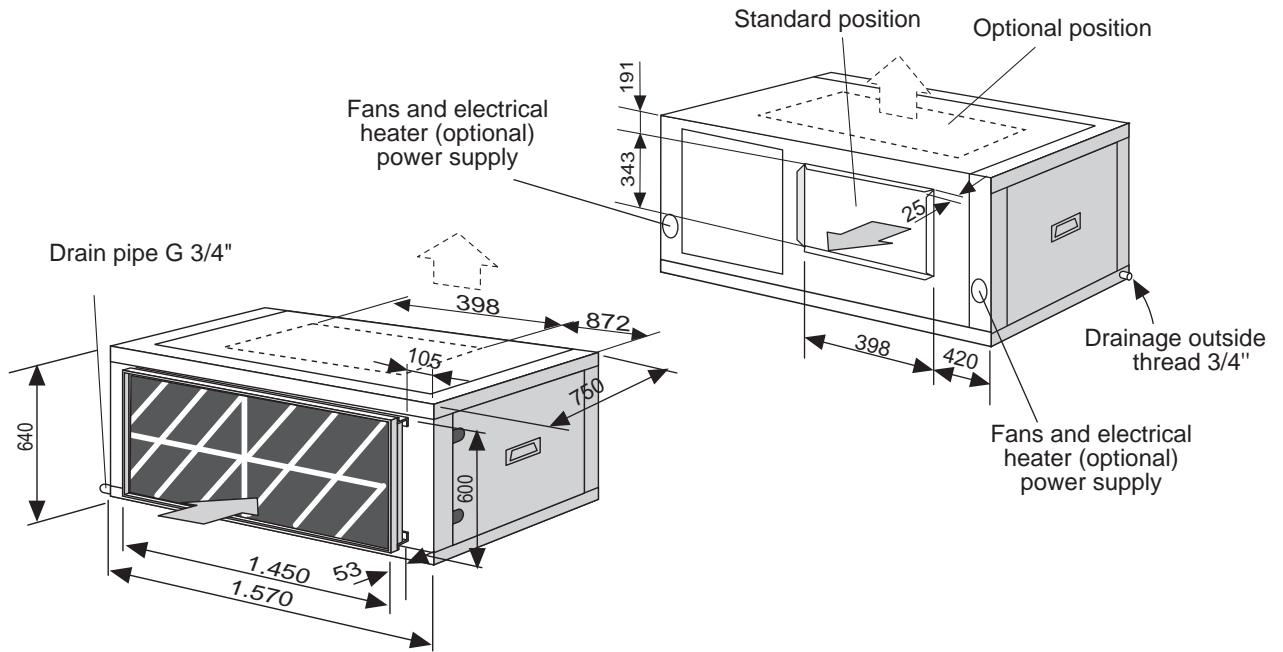

MODELS LECK/LEHK 48D-64D

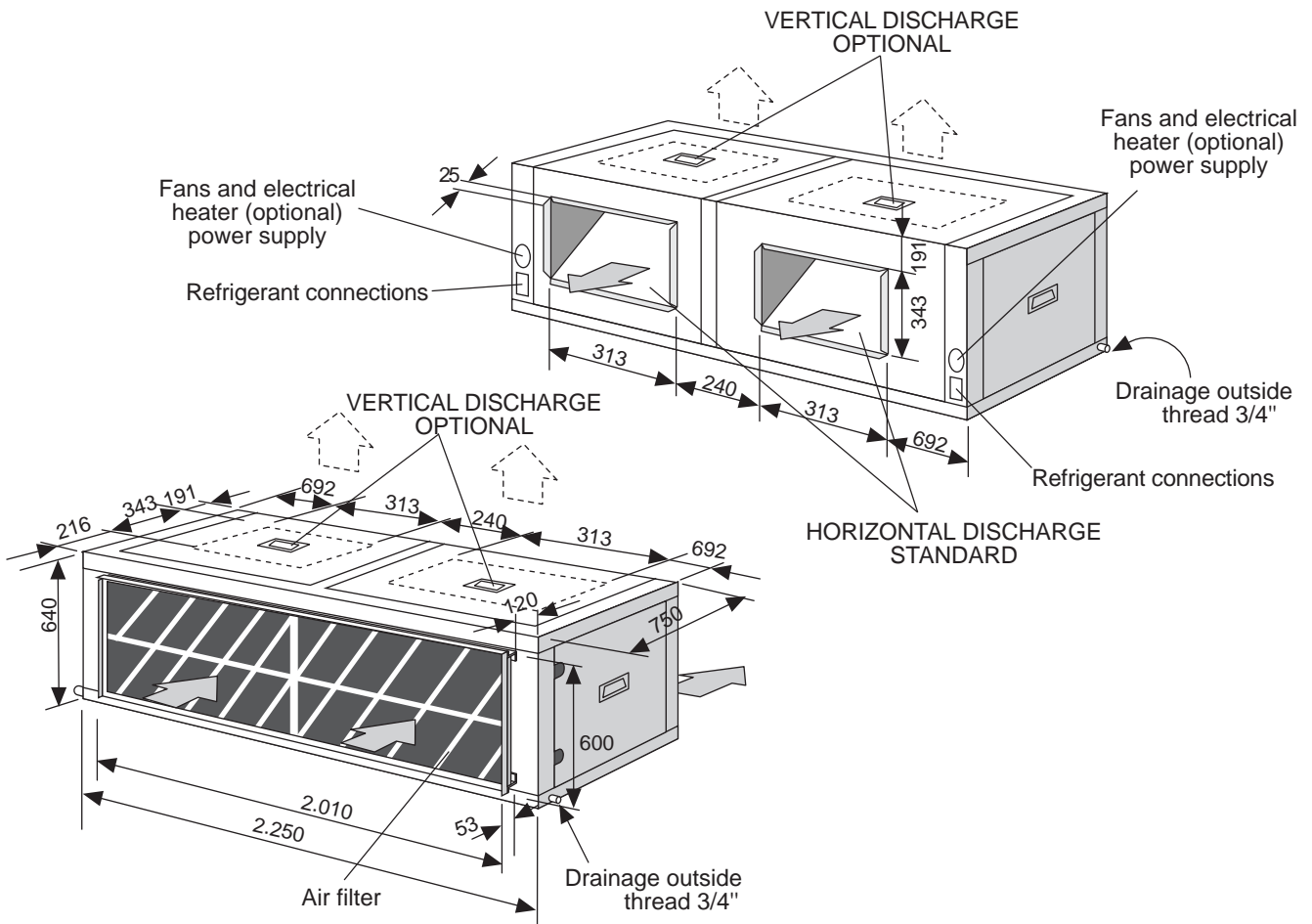

INDOOR SPLIT UNITS DIMENSIONS

MODEL LECK/LEHK 76D

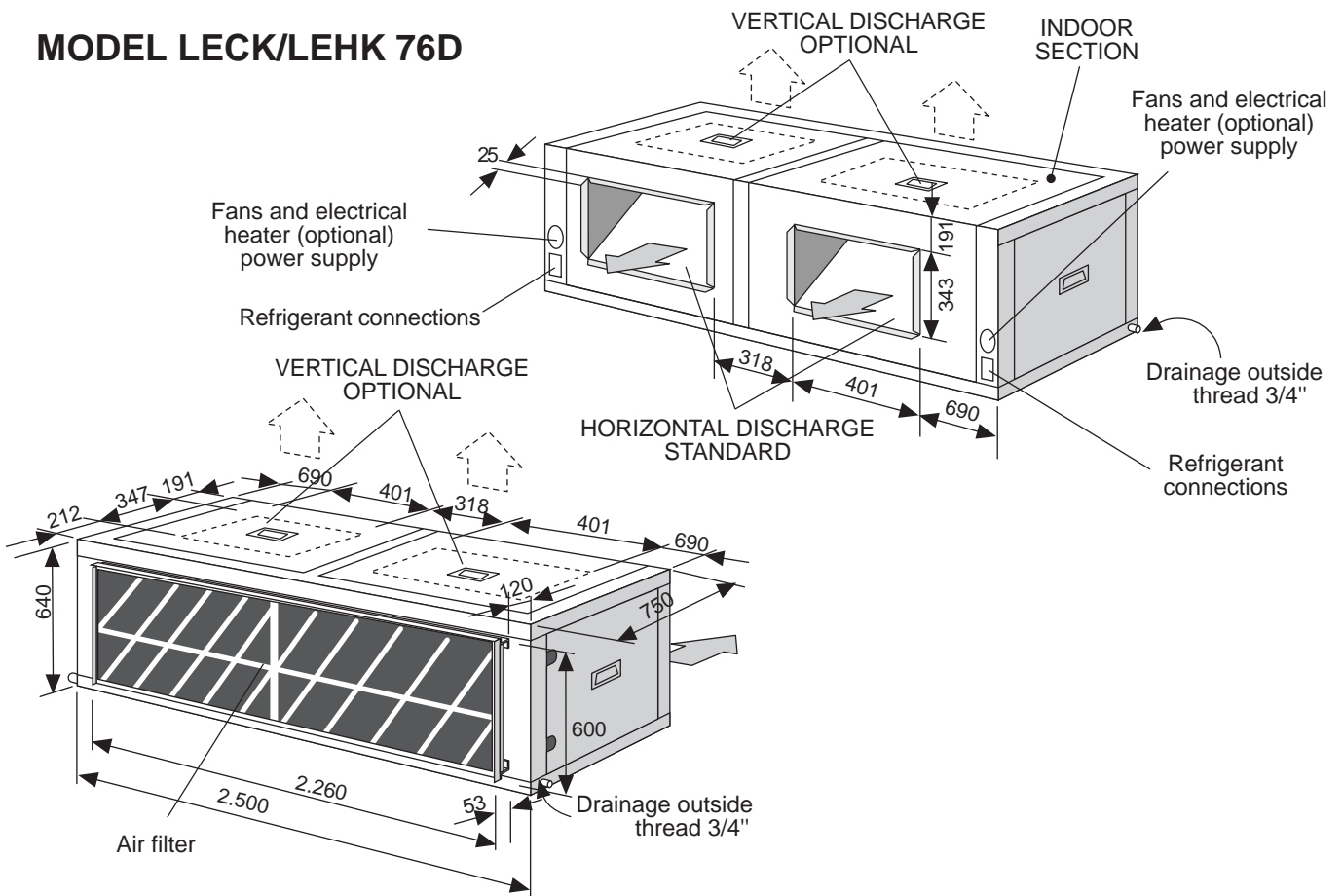

MODELS LECK/LEHK 86D

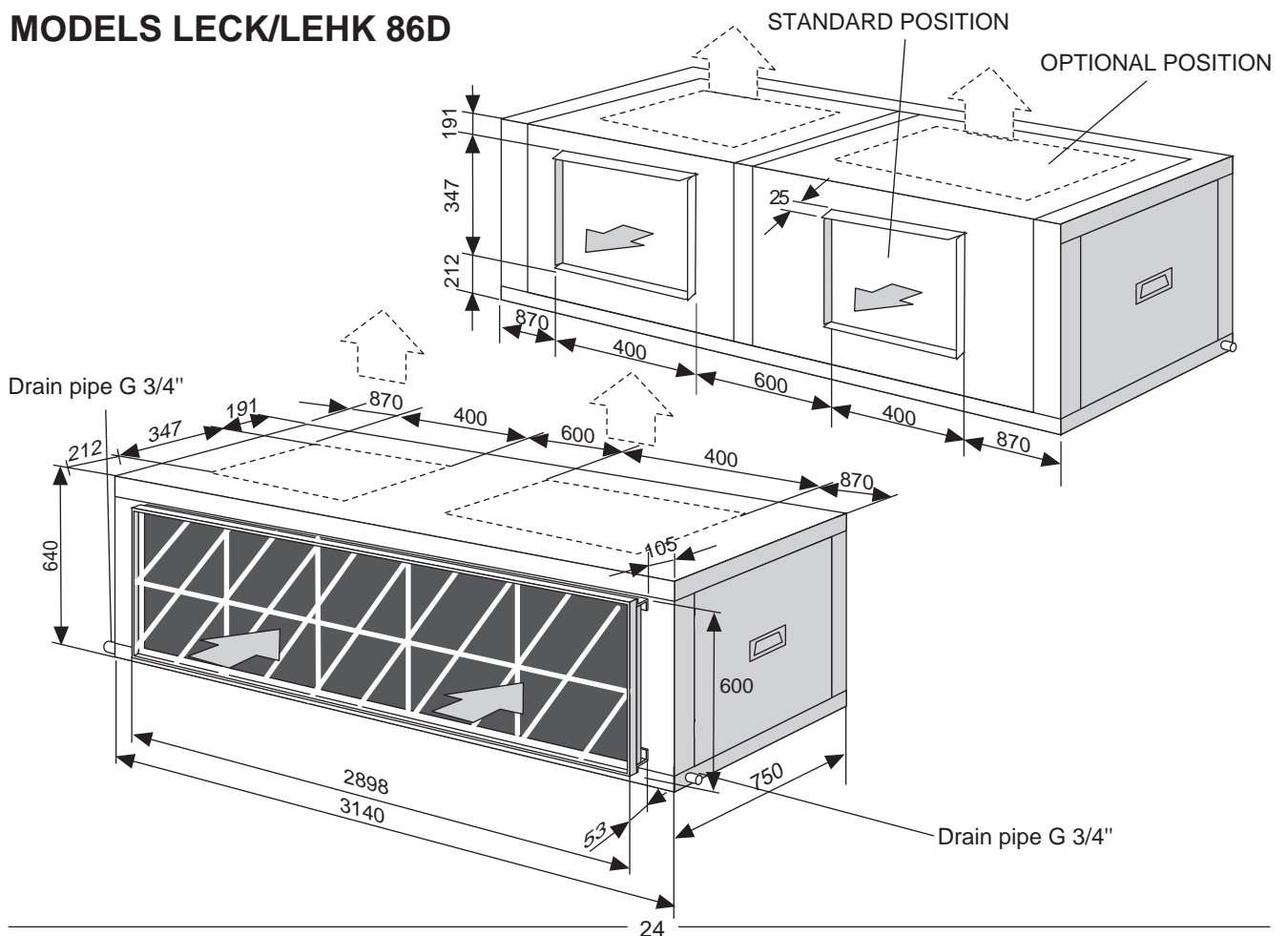

OUTDOOR SPLIT UNITS DIMENSIONS

**MODEL
KNCK/KNHK 24E**

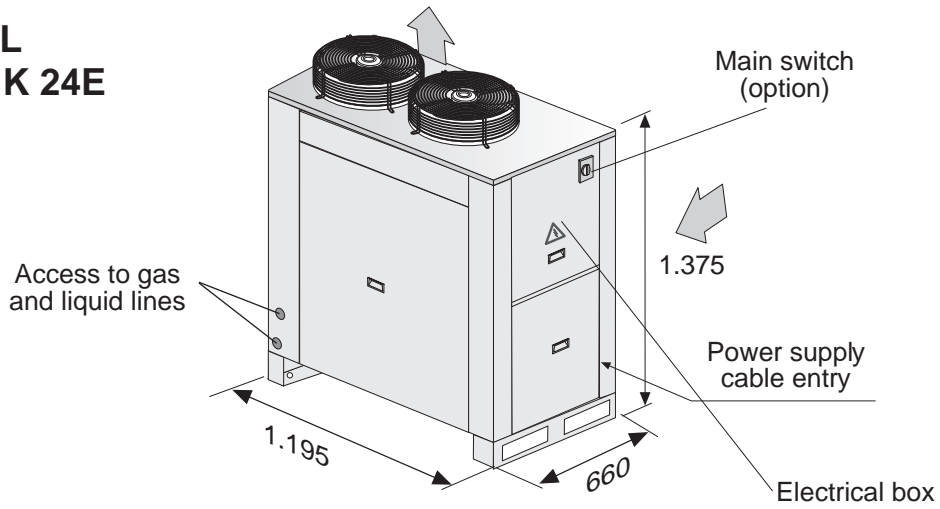

**MODELS
KNCK/KNHK 32E-38E-43E**

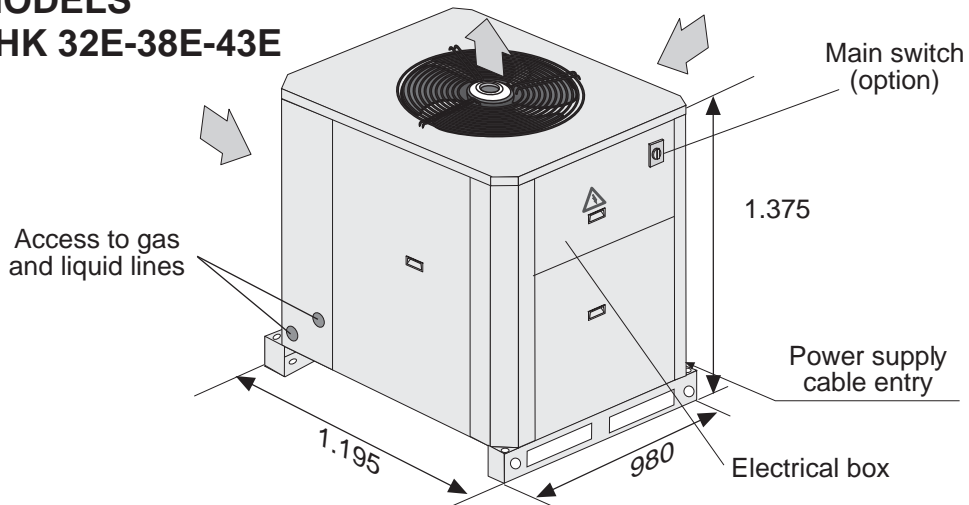

**MODELS KNCK/KNHK
48D-64D-76D-86D
48D2-64D2-76D2-86D2**

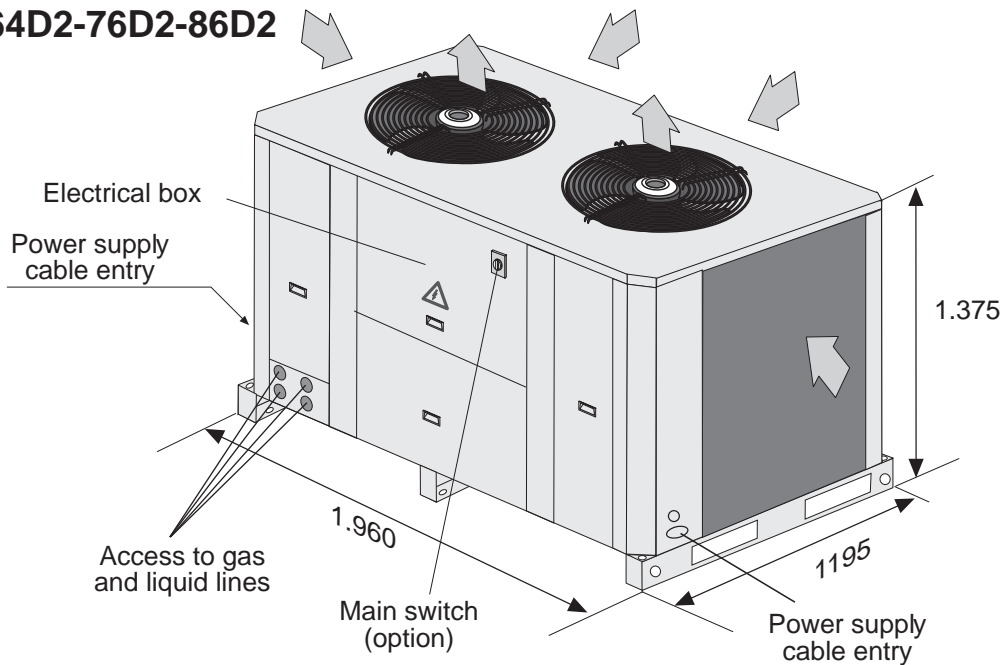

UNITS MODELS LECK-LEHK 24E-32E-38E-43E

STANDARD AIR DISCHARGE

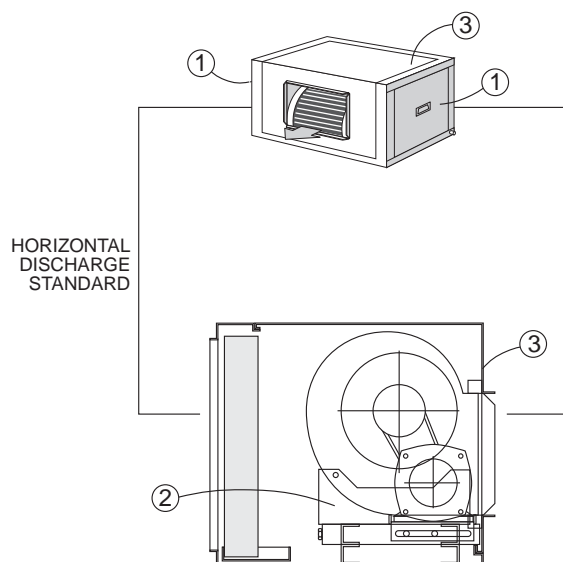

OPTIONAL AIR DISCHARGE

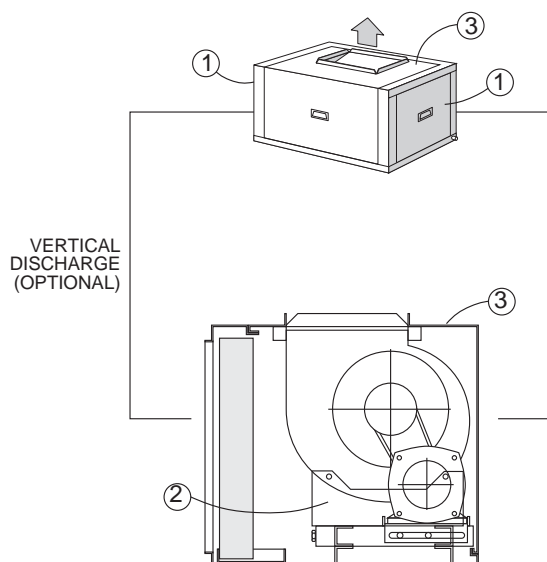

- 1 Check that unit is electrically disconnected.
- 2 Unscrew and remove side covers (1) and (3).
- 3 Loosen the transmission belts and disassemble them.
- 4 Remove the pulley from the fan axle.
- 5 Remove the fan and their supports (2).
- 6 Turn the fan until horizontal discharge position is reached.
- 7 Replace the fan on the supports (2) which should not be moved.
- 8 Place the pulley on the fan axle on the side which coincides with the motor, assemble the belts and align them.
- 9 Tense the belts correctly.
- 10 Replace the upper and lateral covers and screw them down (1) and (3).

TRANSFORMATION OF AIR DISCHARGE

UNITS MODELS LECK-LEHK 48D-64D-76D-86D

STANDARD AIR DISCHARGE

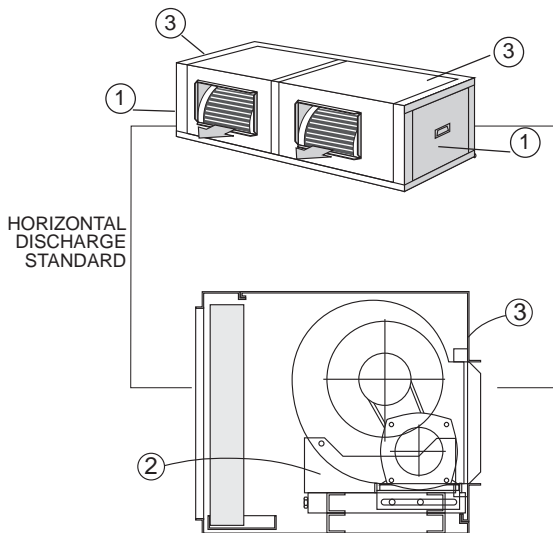

OPTIONAL AIR DISCHARGE

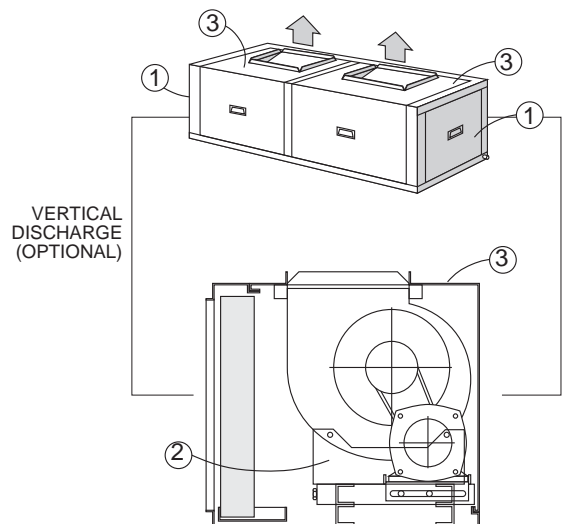

- 1 Check that unit is electrically disconnected.
- 2 Unscrew and remove side covers (1) and (3).
- 3 Loosen the transmission belts and disassemble them.
- 4 Remove the pulley from the fan axle.
ATTENTION!! Models 86D: unscrew the bottom bedplate.
- 5 Remove the fan and its supports (2).
- 6 Turn the fan until horizontal discharge position is reached.
- 7 Replace the fan on the supports (2) which should not be moved.
ATTENTION!! Models 86D: screw the bottom bedplate.
- 8 Place the pulley on the fan axle on the side which coincides with the motor, assemble the belts and align them.
- 9 Tense the belts correctly.
- 10 Replace the upper and lateral covers and screw them down (1) and (3).

OUTDOOR UNIT INSTALLATION

UNIT LOCATION

- The bedplate is made up of metal channels, capable of withstanding the weight of the units.

- If the unit is floor mounted, then the profiles should be isolated with shock absorbing material such as anti-vibration or pads. Keep in mind that fans rotate at approximately 850 rpm.

- The unit is able to work in normal radioelectronics conditions for commercials and residential installations. For any other conditions please consult.

- If the outside temperature in the area where the heat pump unit is to be installed is low or the cycle functioning are too long, it may necessary to install an electrical heater, below the likely coils on the drip tray, which avoids the causing of ice in the coil during defrost cycle.

UNIT INSTALLED ON SHOCK ABSORBERS

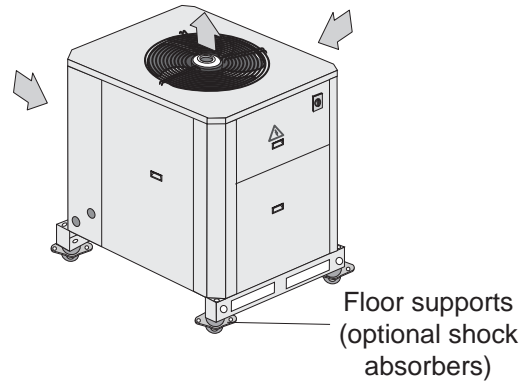

MOUNTING PLATES

MODEL 24E

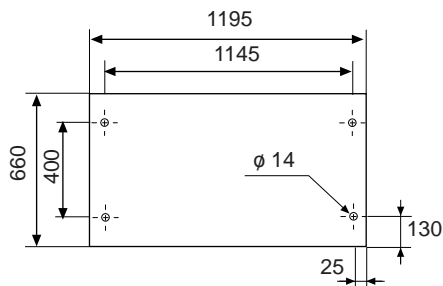

MODELS 32E-38E-43E

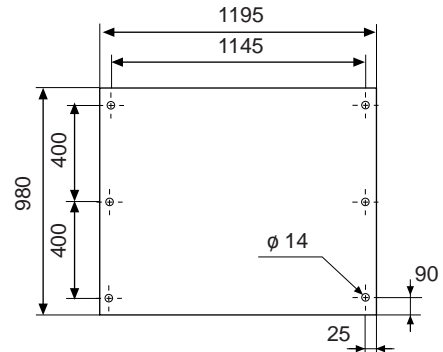

MODELS 48D-64D-76D-86D

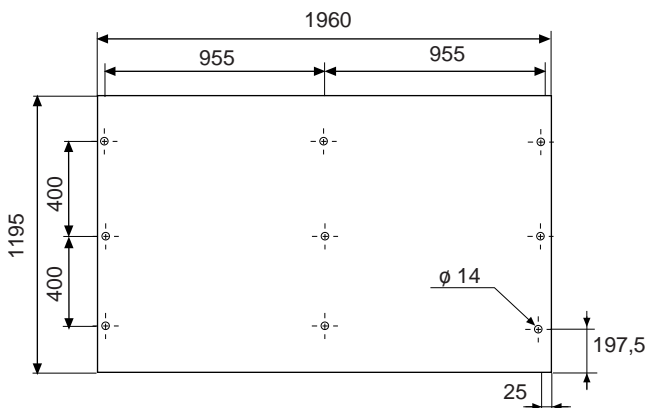

sizes in mm

OUTDOOR UNIT INSTALLATION

INSTALLATION CLEARANCES

Clearance around the unit for service and maintenance.

SERVICE SPACE

Space should be left free for access or servicing, to ease the installation of cables, drainage connections, electric installation and cleaning filters, as well as easy access to the unit.

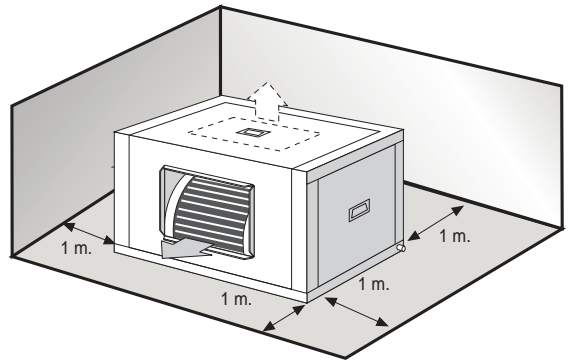
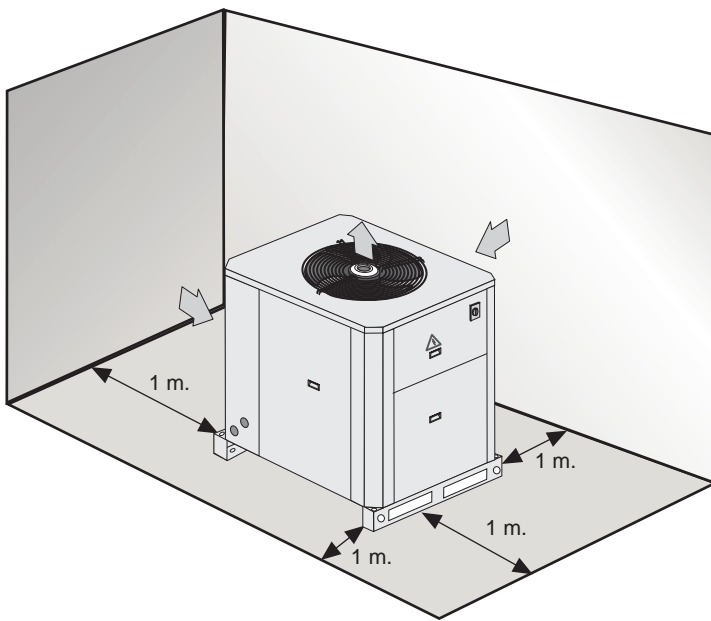

DRAINS (INDOOR UNIT)

All the indoor sections have a $\frac{3}{4}$ " steel threaded drain pipe welded to the condensation tray.

Drainage pipes will be fitted for each tray through a siphon with a height difference of 80 mm. to avoid drainage problems from the depression formed by the fans. The pipes should have an inclination of 2% to ease drainage of condensation.

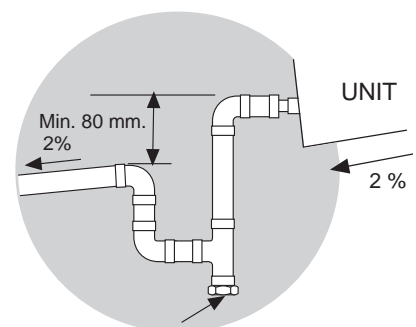

Inspection and cleaning stopper.

Also slightly tip the unit (2%) toward the drainage side. Check that the condensation trays are clean and free from dirt and other debris from the works and that water drains correctly.

REFRIGERANT CONNECTIONS

To locate the outdoor and the indoor units, refer to the following information:

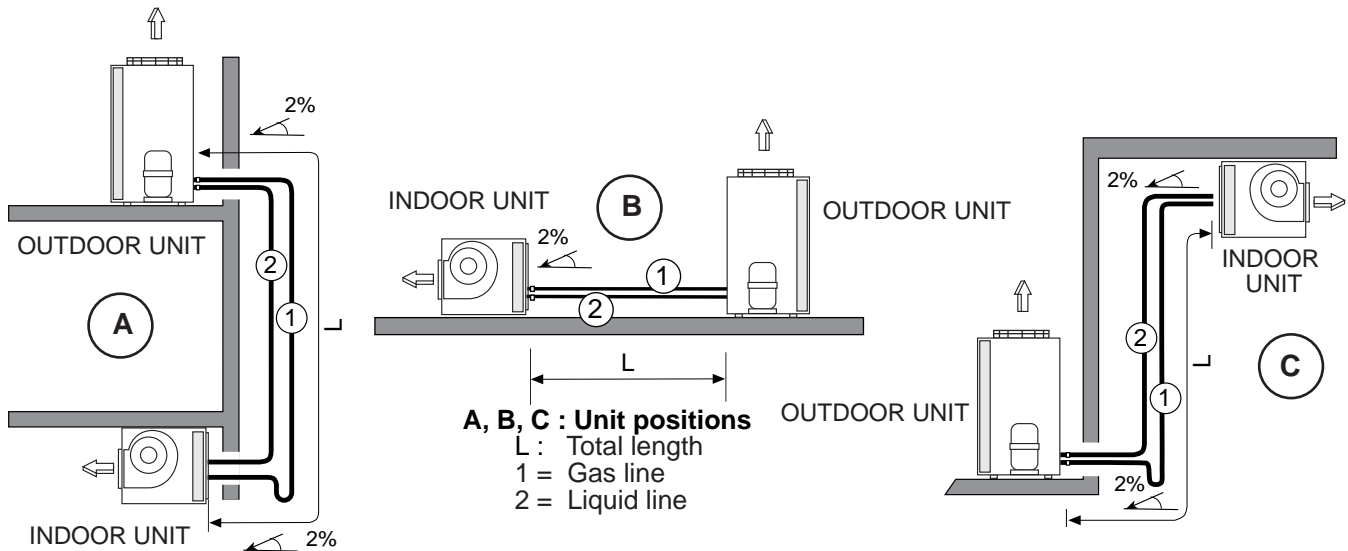

POSITION A : A siphon suction must be installed on the vertical line of the gas line, and siphons must be installed every 8 meters upward. The minimum speed suction must be below 6m/s.

POSITION B : Tip the lines toward the outdoor unit. **Make special attention to line length longer than 10m, and avoid collapse on pipe lines installation.**

POSITION C : Install a siphon at the base of the vertical of the gas line, no more siphons are necessary.

TABLE 1: REFRIGERANT LINES SELECTION

REFRIGERANT LINES			UNIT - MODEL							
			24E	32E	38E	43E	48D 48D2	64D 64D2	76D 76D2	86D 86D2
Total line length	0 a 10 m.	∅ Liquid	5/8"	5/8"	3/4"	7/8"	2x5/8"	2x5/8"	2x3/4"	2x7/8"
		∅ Gas	1-1/8"	1-1/8"	1-3/8"	1-5/8"	2x 1-1/8"	2x 1-1/8"	2x 1-3/8"	2x 1-5/8"
	0 a 30 m.	∅ Liquid	5/8"	3/4"	7/8"	7/8"	2x5/8"	2x3/4"	2x7/8"	2x7/8"
		∅ Gas	1-1/8"	1-3/8"	1-5/8"	1-5/8"	2x 1-1/8"	2x 1-3/8"	2x 1-5/8"	2x 1-5/8"
	30 a 50 m. 	∅ Liquid	3/4"	3/4"	7/8"	7/8"	2x3/4"	2x3/4"	2x7/8"	2x7/8"
		∅ Gas	1-3/8"	1-3/8"	1-5/8"	2-1/8"	2x 1-3/8"	2x 1-3/8"	2x 1-5/8"	2x 2-1/8"
Unit connections	∅ Liquid	5/8"	5/8"	3/4"	7/8"	2x5/8"	2x5/8"	2x3/4"	2x7/8"	
	∅ Gas	1-1/8"	1-1/8"	1-3/8"	1-5/8"	2x 1-1/8"	2x 1-1/8"	2x 1-3/8"	2x 1-5/8"	
Maximum vertical line length (m.)			16	16	16	16	16	16	16	16
Maximum number of bends			12	12	12	12	12	12	12	12

NOTE: The units are supplied with welded connections. As an option, service valves are available for liquid and gas lines.

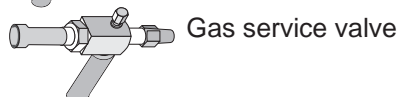
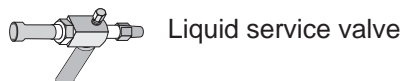

- THE GAS LINE ALWAYS MUST BE INSULATED
- THE HORIZONTAL LINES MUST BE TIPPED AT LEAST 2% TOWARD THE OUTDOOR UNIT
- THE MAXIMUM SPEED INSIDE LINES, SHOULD NOT BE MORE THAN 15 m/seg.



Between lengths of 30 and 50 m superior you have to make a recalculation according to our technical commercial department or distribution itself to maintain certain aspects how to make the installation (additional charge of oil, solenoid valves etc...)



PRECAUTIONS TO BE TAKEN IN THE USE OF R-407C Refrigerant

If R-407C Refrigerant is used in the unit, the following precautions characteristic of this gas should be taken:

- The Vacuum Pump must have a Check Valve or Solenoid Valve.
- Pressure Gauges and Hoses for the exclusive use with R-407C Refrigerant should be used.
- The charge should be carried out in the Liquid Phase.
- Always use scales to weight-in charge- Use the Leak Detector exclusive for R-407C Refrigerant.
- Do not use mineral oil, only synthetic oil to ream, expand or make connections.
- Keep pipes wrapped before using them and be very thorough about any possible dirt (dust, filings, burrs, etc.).
- When there is a leak, gather what is left of the charge, create a vacuum in the unit and completely recharge with new R-407C Refrigerant.
- Brazing should always be carried out in a nitrogen atmosphere.
- Reamers should always be well sharpened.

REFRIGERANT CONNECTIONS



Indoor and outdoor units are factory pre-charged with Nitrogen (N₂). The installer should remove this gas and charge the units with refrigerant R-407C shown on the following tables

The unit is supplied as standard with welded connections. As an option, factory pre-charged kit is available. If so, TABLE 2 is the only to take care about (this option includes service valves).

TABLE 2: WEIGHT OF REFRIGERANT R-407C PER METER OF LINE

	FROM 0 TO 10M			FROM 10 TO 30M			FROM 30 TO 50M		
	Suction	Liquid	gr/m	Suction	Liquid	gr/m	Suction	Liquid	gr/m
MODEL 24E	1-1/8"	5/8"	155	1-1/8"	5/8"	155	1-3/8"	3/4"	232
MODEL 32E	1-1/8"	5/8"	155	1-3/8"	3/4"	232	1-3/8"	3/4"	232
MODEL 38E	1-3/8"	3/4"	232	1-5/8"	7/8"	327	1-5/8"	7/8"	327
MODEL 43E	1-5/8"	7/8"	327	1-5/8"	7/8"	327	2-1/8"	7/8"	340
MODELS 48D / D2	2x1-1/8"	2x5/8"	2x155	2x1-1/8"	2x5/8"	2x155	2x1-3/8"	2x3/4"	2x232
MODELS 64D / D2	2x1-1/8"	2x5/8"	2x155	2x1-3/8"	2x3/4"	2x232	2x1-3/8"	2x3/4"	2x232
MODELS 76D / D2	2x1-3/8"	2x3/4"	2x232	2x1-5/8"	2x7/8"	2x327	2x1-5/8"	2x7/8"	2x327
MODELS 86D / D2	2x1-5/8"	2x7/8"	2x327	2x1-5/8"	2x7/8"	2x327	2x1-3/8"	2x7/8"	2x340

TABLE 3.1.: CHARGE OF REFRIGERANT

Charge of refrigerant (gr) R-407C for 0 meters of line KNCK + LECK							
24E	32E	38E	43E	48D	64D	76D	86D
	5600				11200		

Charge of refrigerant (gr) R-407C for 0 meters of line KNHK + LEHK							
24E	32E	38E	43E	48D	64D	76D	86D
	6250				12500		

TABLE 3.2.: CHARGE OF REFRIGERANT FOR MULTI-SPLIT SYSTEM

Charge of refrigerant (gr) R-407C KNCK + 2 x LECK			
48D2	64D2	76D2	86D2
	2 x 5600		

Charge of refrigerant (gr) R-407C KNHK + 2 x LEHK			
48D2	64D2	76D2	86D2
	2 x 6250		

CHARGE OF REFRIGERANT FOR THE SET:

EXAMPLE:

To install a KNHK 32E + LEHK 32E set, with a 22m refrigerant line length between outdoor and indoor unit, then the refrigerant charge must be calculated as follow:

1° The TABLE 2 shows, that for 22m of line length between indoor unit and outdoor unit, the line sizes are: liquid 3/4", and gas 1-3/8".

2° TABLE 2 shows, for line sizes of 3/4"- 1-7/8", the charge per meter line is: 232 gr/m.

3° TABLE 3.1. shows, charge of refrigerant for the set with 0m of line length is 6.250 gr.

4° To determinate the charge of the set:

Add charge of the refrigerant lines + charge of refrigerant indoor unit and outdoor unit.

$$\text{Total charge for the set: } (232 \text{ gr/m}) \times 22 \text{ m} + 6.250 \text{ gr} = 11.354 \text{ gr}$$

Note: if the outdoor unit includes factory pre-charged kit, only take care of weight of refrigerant per meter of line in TABLE 2.

ELECTRICAL CONNECTION



- BEFORE MAKING ANY ELECTRICAL CONNECTIONS, BE SURE THAT ALL CIRCUIT BREAKERS ARE OPEN.
- IN ORDER TO CARRY OUT THE ELECTRICAL CONNECTIONS, FOLLOW THE ELECTRICAL DIAGRAM SUPPLIED WITH THE UNIT.

FOR UNIT MODELS:

**24E-32E-38E-43E
48D-64D-76D-86D**

- ① Power supply.
- ② Indoor motor fan electrical connection.

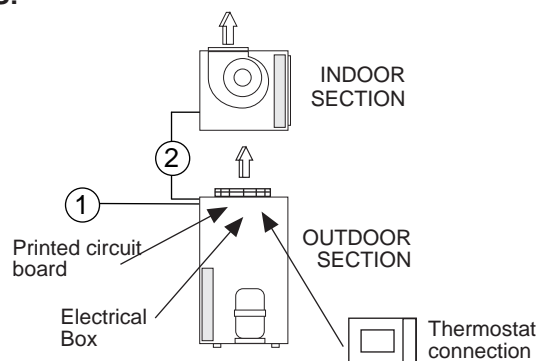

POWER SUPPLY 230V THREE-PHASE UNITS	UNIT MODEL	Nr OF CABLES X SECTION (mm ²)			
		①	①	②	
		Power supply WITHOUT electrical heater	Power supply WITH electrical heater	Indoor motor fan electrical connection	Power supply electrical heater
<p>3 ~ 230V - 50 Hz + PE</p>	24E	4 x 10	4 x 25	4 x 1,5	
	32E	4 x 16	4 x 25	4 x 1,5	
	38E	4 x 16	4 x 35	4 x 1,5	
	43E	4 x 25	4 x 35	4 x 2,5	
	48D	4 x 25	4 x 70	4 x 2,5	
	64D	4 x 50	4 x 95	4 x 2,5	
	76D	4 x 50	4 x 95	4 x 2,5	
	86D	4 x 95	4 x 120	4 x 2,5	

POWER SUPPLY 400V THREE-PHASE UNITS	UNIT MODEL	Nr OF CABLES X SECTION (mm ²)			
		①	①	②	
		Power supply WITHOUT electrical heater	Power supply WITH electrical heater	Indoor motor fan electrical connection	Power supply electrical heater
<p>3N ~ 400V - 50 Hz + PE</p>	24E	5 x 4	5 x 10	4 x 1,5	
	32E	5 x 6	5 x 16	4 x 1,5	
	38E	5 x 10	5 x 16	4 x 1,5	
	43E	5 x 10	5 x 25	4 x 2,5	
	48D	5 x 10	5 x 25	4 x 2,5	
	64D	5 x 25	5 x 35	4 x 2,5	
	76D	5 x 25	5 x 50	4 x 2,5	
	86D	5 x 35	5 x 50	4 x 2,5	

- The sections have been calculated for a length no longer than 50 m and a voltage drop of 10V.

ELECTRICAL CONNECTION

MULTI-SPLIT UNIT



- BEFORE MAKING ANY ELECTRICAL CONNECTIONS, BE SURE THAT ALL CIRCUIT BREAKERS ARE OPEN.
- IN ORDER TO CARRY OUT THE ELECTRICAL CONNECTIONS, FOLLOW THE ELECTRICAL DIAGRAM SUPPLIED WITH THE UNIT.

- ① Power supply.
- ② Indoor motor fan electrical connection.

FOR UNITS MODELS:

48D2-64D2-76D2-86D2

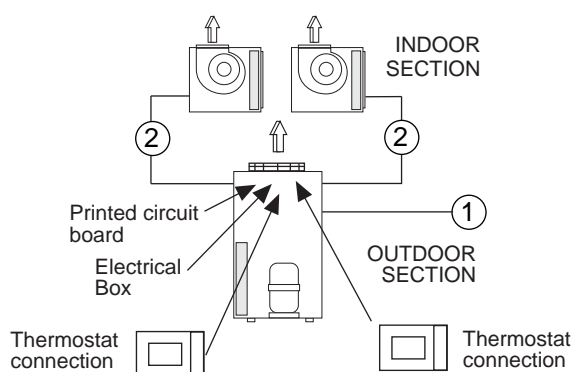

POWER SUPPLY 230V THREE-PHASE UNITS	UNIT MODEL	Nr OF CABLES X SECTION (mm ²)			
		① Power supply WITHOUT electrical heater	① Power supply WITH electrical heater	② Indoor motor fan electrical connection	Power supply electrical heater
 3 ~ 230V - 50 Hz + PE	48D2	4 x 25	4 x 70	2 x (4 x 1,5)	
	64D2	4 x 50	4 x 95	2 x (4 x 1,5)	
	76D2	4 x 50	4 x 95	2 x (4 x 1,5)	
	86D2	4 x 95	4 x 120	2 x (4 x 2,5)	

POWER SUPPLY 400V THREE-PHASE UNITS	UNIT MODEL	Nr OF CABLES X SECTION (mm ²)			
		① Power supply WITHOUT electrical heater	① Power supply WITH electrical heater	② Indoor motor fan electrical connection	Power supply electrical heater
 3N ~ 400V - 50 Hz + PE	48D2	5 x 10	5 x 25	2 x (4 x 1,5)	
	64D2	5 x 25	5 x 35	2 x (4 x 1,5)	
	76D2	5 x 25	5 x 50	2 x (4 x 1,5)	
	86D2	5 x 35	5 x 50	2 x (4 x 2,5)	

- The sections have been calculated for a length no longer than 50m and a voltage drop of 10V.

VOLTAGE OPERATING LIMITS

MODELS	VOLTAGE	LIMIT
24E/48D/48D2	230 V-3Ph-50Hz	180-242 V -3Ph- 50Hz
32E/64D/64D2	230 V-3Ph-50Hz	198-264 V -3Ph- 50Hz
38E/76D/76D2	400 V-3Ph-50Hz	342-462 V -3Ph- 50Hz
86D/86D2	230 V-3Ph-50Hz	198-264 V -3Ph- 50Hz
86D/86D2	400 V-3Ph-50Hz	342-462 V -3Ph- 50Hz

ELECTRICAL CONNECTION

CONTROL PANEL

ELECTRICAL CONNECTION DIGITAL THERMOSTAT, FOR STANDARD UNIT VERSION



IMPORTANT

THE SHIELDED CONNECTION CABLE BETWEEN THE CONTROL PANEL AND THE UNIT MUST BE SEPARATE FROM ANY OTHER TYPE OF ELECTRICAL WIRING. CONNECT IT TO THE ELECTRIC BOX LOCATED IN THE OUTDOOR UNIT.

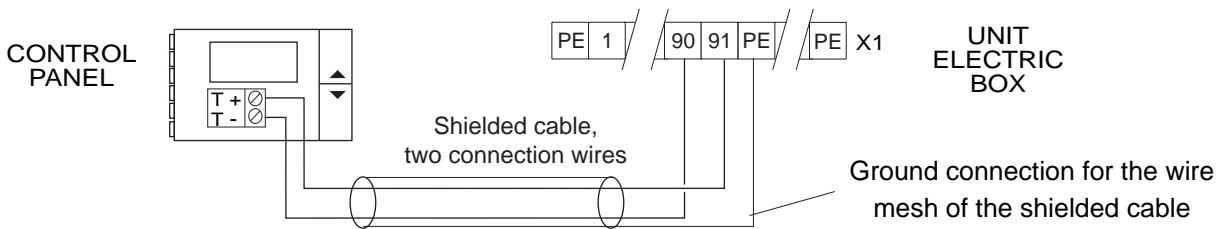

- For securing and connecting the Control Panel, consult the control Panel Manual supplied with the unit.
- Keep in mind that the Control Panel cable is a SHIELDED CABLE and the wire mesh is only grounded through the electric box.
- The T+ and T- polarity must strictly agree with the electrical diagram supplied with the unit.



Since this type of control panel is factory-configured for each application, an identification code located on the control plate of the terminal itself has been given to each panel.

Any query or request for a replacement of the control panel must be accompanied by this identification code.

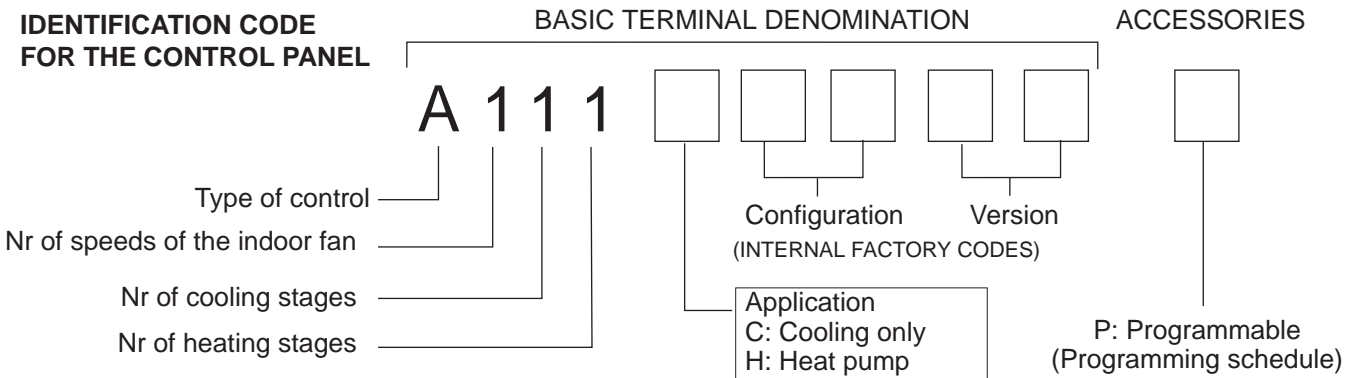

ELECTRICAL CONNECTION

ELECTRICAL CONNECTION " REMOTE SIGNALS "

The electrical box of all the range, lets you obtain the following functions:

- Remote ON / OFF.
- Alarm and failure signals for the unit's components: FM, CM.
- The unit's functioning mode signals: FM, CM, EH.
- Dirty air filter indication (option).
- Manage the unit operation, through the supplied thermostat or through the digital inputs for a BMS system (only for VFC unit version).

SINGLE CIRCUIT UNIT, STANDARD VERSION

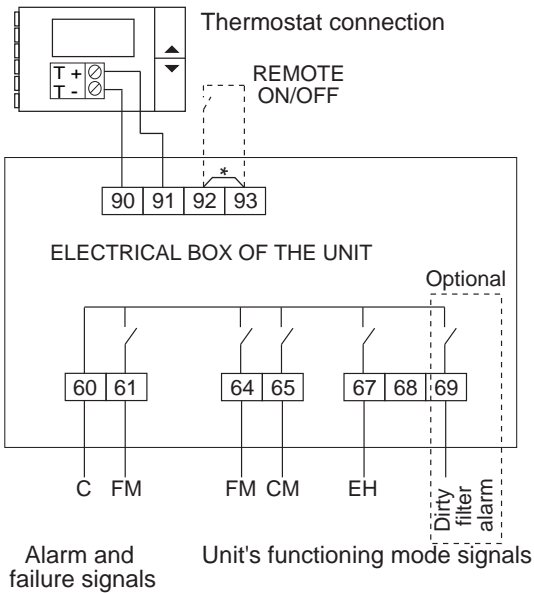

SINGLE CIRCUIT UNIT, VFC VERSION

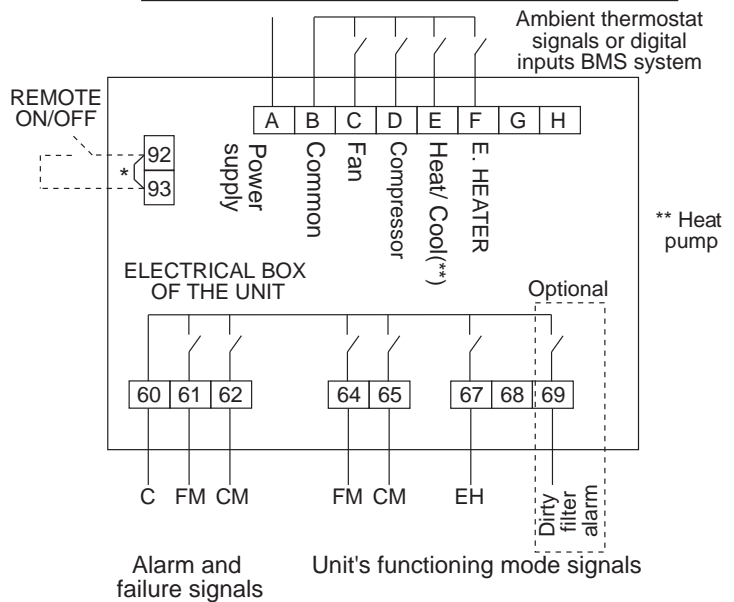

DOUBLE CIRCUIT UNIT, STANDARD VERSION

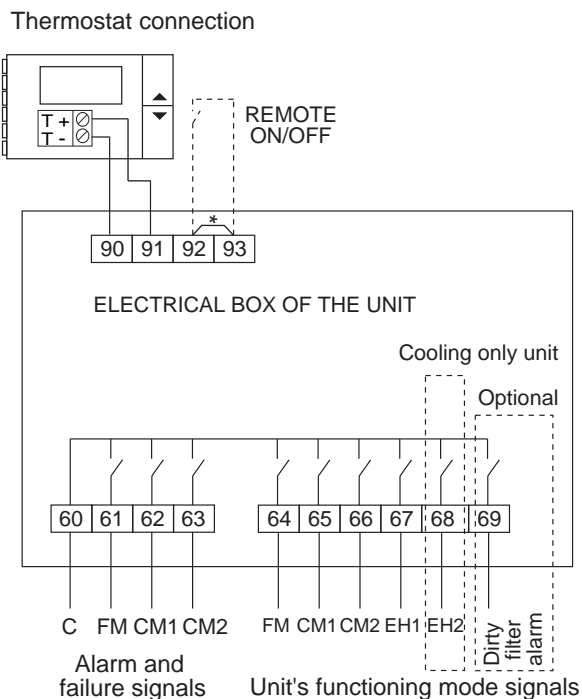

DOUBLE CIRCUIT UNIT, VFC VERSION

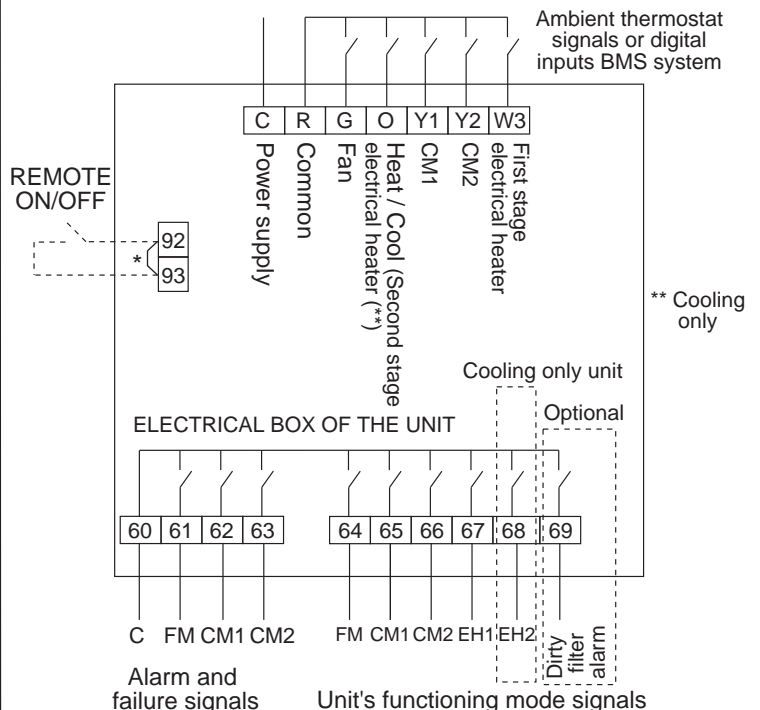

C: Common
 FM: Indoor fan
 CM: Compressor
 CM1: Compressor 1
 CM2: Compressor 2
 EH1: Electrical heater 1
 EH2: Electrical heater 2

When unit switches off, the system will show CM, CM1 and CM2 failure signal.

* Remove wire, if ON/OFF remote is used.

ELECTRICAL CONNECTION

ELECTRICAL CONNECTION " REMOTE SIGNALS" MULTI-SPLIT SYSTEMS

STANDARD VERSION UNIT MULTI-SPLIT SYSTEM

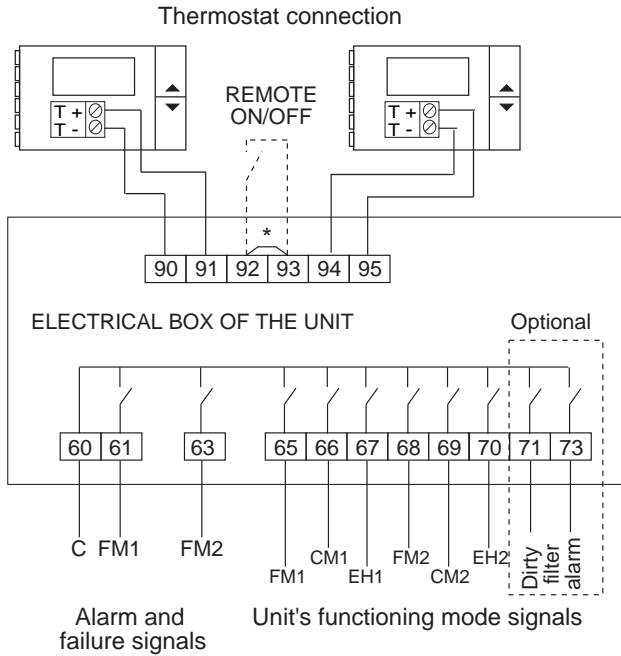

VFC VERSION UNIT MULTI-SPLIT SYSTEM

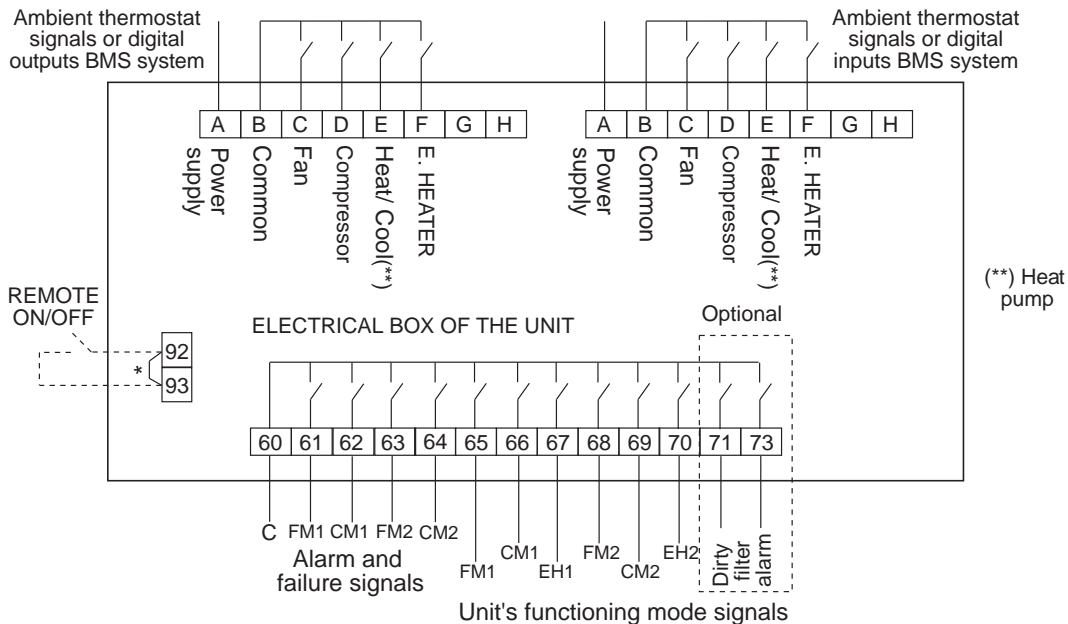

C: Common
 FM: Indoor fan
 CM1: Compressor 1
 CM2: Compressor 2
 EH1: Electrical heater 1
 EH2: Electrical heater 2

When unit switches off, the system will show CM1 and CM2 failure signal.

* Remove wire, if ON/OFF remote is used.

OPERATING LIMITS

OPERATING LIMITS FOR (COOLING ONLY) UNITS

		MAXIMUM TEMPERATURES	MINIMUM TEMPERATURES
COOLING CYCLE OPERATION	INDOOR TEMPERATURE	32° C DB / 23°C WB	21° C DB / 15°C WB
	OUTDOOR TEMPERATURE	DEPENDING ON MODEL (see Tables for cooling capacities)	+19° C STANDARD UNIT +15°C WITH MINIMUM INDOOR TEMPERATURES 24°C DB/ 18°C WB 0° C WITH OPTIONAL CPC ON/OFF -10°C (*)

(*) With hot gas bypass kit or proportional CPC (options)

OPERATING LIMITS FOR (HEATING PUMP) UNITS

		MAXIMUM TEMPERATURES	MINIMUM TEMPERATURES
COOLING CYCLE OPERATION	INDOOR TEMPERATURE	32° C DB / 23°C WB	21° C DB / 15°C WB
	OUTDOOR TEMPERATURE	DEPENDING ON MODEL (see Tables for cooling capacities)	+19° C STANDARD UNIT +15°C WITH MINIMUM INDOOR TEMPERATURES 24°C DB/ 18°C WB 0° C WITH OPTIONAL CPC ON/OFF -10°C (*)
HEATING CYCLE OPERATION	INDOOR TEMPERATURE	27° C DB	15°C WB
	OUTDOOR TEMPERATURE	DEPENDING ON MODEL (see Tables for heating capacities)	-10° C DB / -11°C WB

(*) With hot gas bypass kit or proportional CPC (options)

DB.- Dry Bulb Temperature
WB.- Wet Bulb Temperature

OPTIONS

ELECTRICAL HEATER

Made of aligned shielded elements, supplied mounted on the unit as drawing shows.

All the range has three security elements: 2 security thermostats, one automatic, other manual reset, and an air flow security pressostat, which makes the electrical heater stop when air flow is not enough.

The electrical heater must be supplied from the unit's electrical box.

An small case on the electrical heater protects contactors and electrical connections.

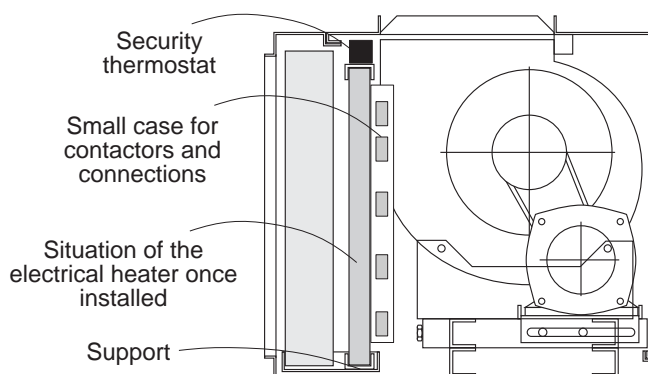

MODELS LEC (INDOOR UNIT)	24E-32E-38E			43E		48D-64D-76D				86D		
POWER Kw	7,5	11	15	11	15	11	15	20	30	22,5	30	
MAXIMUM CURRENT (A)	230 / III	18,8	27,6	37,7	27,6	37,7	27,6	37,7	50,2	75,3	56,5	75,3
	400/ III	10,8	15,9	21,7	15,9	21,7	15,9	21,7	28,9	43,3	32,5	43,3
WEIGHTS Kg (*)	10			10		20				30		
STAGES	1			1		2				2		

(*) Add to the unit's weight.

MODELS LEH (INDOOR UNIT)	24E-32E-38E			43E		48D-64D-76D				86D	
POWER Kw	7,5	11	15	11	15	11	15	20	15	22,5	
MAXIMUM CURRENT (A)	230 / III	18,8	27,6	37,7	27,6	37,7	27,6	37,7	50,2	37,7	56,5
	400/ III	10,8	15,9	21,7	15,9	21,7	15,9	21,7	28,9	21,7	32,5
WEIGHTS Kg (*)	10			10		20				30	
STAGES	1			1		1				1	

(*) Add to the unit's weight.

DIRTY FILTER INDICATION

To be installed on the indoor unit.

Based on an air flow security pressostat which detects the available static pressure through the air filter.

In case the filters are dirty, the detector is activated showing an alarm, only if the fan is ON.

MAIN SWITCH

The main switch is located on the access panel to the electrical box of the outdoor unit (except 86D models).

The main switch is equipped with a clutch gadget, which allows opening the panel of the electrical box, when it is on OFF position.

Verify that the main switch is large enough to handle the current for the unit if electric heaters are installed.

OPTIONS

HOT WATER COIL

The hot water coil consists of a refrigerating coil made of copper tubing, with aluminum swirl fins with inlet and outlet water connections. It is supplied mounted inside the unit as picture shows.

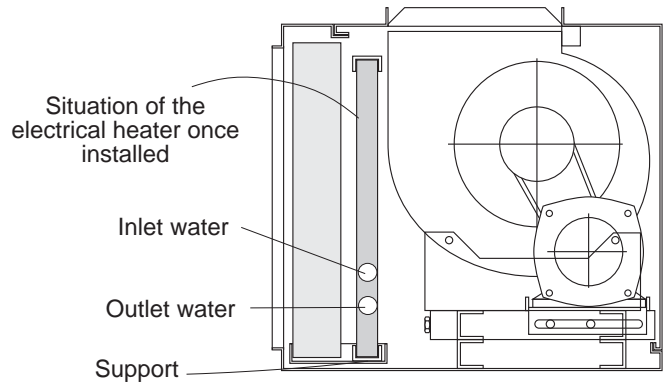

MODELS LEC / LEH INDOOR UNIT CAPACITY IN W	DIFFERENCE IN TEMPERATURES BETWEEN HOT WATER INTAKE AND THE AIR WHICH ENTERS THE COIL			WATER FLOW L/H	WATER COIL PRESSURE DROP Kpa	AIR PRESSURE DROP Pa (*)	Nr ROWS	WEIGHT Kg	OUTLET WATER DIAMETER Inches
	50°C	60°C	70°C						
24E	29.000	36.000	44.000	2.200	8	40	2	10	2
32E	33.000	40.000	47.000	2.500	10	40	2	10	2
38E	40.000	48.000	56.000	3.000	15	40	2	12	2
48D	58.000	62.000	88.000	4.400	8	40	2	20	2
64D	66.000	80.000	94.000	5.000	10	40	2	20	2
76D	80.000	96.000	112.000	6.000	15	39	2	24	2

(*) Nominal air flow volume

PHASE SEQUENCER

The phase sequencer is located in the electrical box in the outdoor section, thus assuring that the unit will not begin operation while the phase connection of the compressor is not correct. Should this occur, then just switch two phase connections.

ON/OFF CONDENSATION PRESSURE CONTROL (outdoor unit)

The condensation pressure control consists of one or two pressure switches, which starts and stops the outdoor fan, regulating the condensation temperature; thus the unit will be able to operate in the cooling cycle when the outdoor temperature is below 19°C (until 0°C).

It includes crankcase heater for cooling only units. The purpose of the heater is to keep the oil in the compressor at the correct temperature while the compressor is stopped, so that it can be properly lubricated when starts again. When the unit is operating at low outdoor temperatures (indoors 19°C), it is advisable to fit a crankcase heater.

PROPORTIONAL CONDENSING PRESSURE CONTROL (outdoor unit)

It is an element which regulates outdoor fan speed, in order to control condensation temperature. Thus, the unit will be able to operate in the cooling cycles when the outdoor temperature is below 19°C. This kit includes crankcase heater for cooling only units.

COMPRESSOR STARTING CURRENT CONSTRAINED ("SOFT STARTER") 400V-III (outdoor unit)

It is an electronic element, which reduces the peak compressor starting current up to 40% (see pages of electrical data without soft starter).

MODELS (OUTDOOR UNIT)	WEIGHTS (*)
24E-32E-38E-43E	3
48D-64D-76D-86D	6

(*) Add to the unit's weight.

KIT MORE STATIC PRESSURE OF AIR DISCHARGE (indoor unit)

It is a specific fan to obtain more available static pressure up to 400 Pa for indoor unit. See air flow data section for optional fan performances.

Electrical data for these optional fans:

MODELS LEC / H (INDOOR)	24E	32E	38E	43E	48D	64D	76D	86D	
POWER (*) Kw	0,4	1,0	1,0	0,8	0,8	1,5	1,7	1,5	
MAXIMUM CURRENT (*) (A)	230 / III	1,0	2,5	2,5	2,0	2,0	3,8	4,3	3,8
	400/ III	0,6	1,4	1,4	1,2	1,2	2,2	2,5	2,2
WEIGHTS Kg (*)	0	2	0	0	5	9	9	0	

(*) Add to the unit data

HOT GAS BYPASS VALVE (outdoor unit)

The purpose of the BYPASS valve is to let the unit operate at low outdoor temperatures (until -10°C), to be used in cooling only and heat pump units in cooling cycle.

It regulates the capacity of the compressor by injecting hot gas from the compressor discharge side to the coil.

CONTROL USING A PROGRAMMABLE CONTROLLER

With the programmable controller option, the desired temperature can be programmed in the area 24 hours a day, 7 days a week.

REMOTE AMBIENT SENSOR AND REMOTE DUCT SENSOR

These sensors may be used in conjunction with remote controller or allowing the controller to be mounted in a room away from the conditioned space.

REMOTE DUCT SENSOR:

The sensor will be located in the return-air duct, detecting the air temperature of the air being air-conditioned.

REMOTE AMBIENT SENSOR:

The sensor will be placed in the area to be air-conditioned.

CONDENSER COIL GUARD (outdoor unit)

The condenser coil protection grill prevents light damage to the coil when shipping and when installed. It cannot protect against very heavy impacts.

PRECOATED COIL (outdoor unit)

Special protection of the aluminum condenser coil fins, to protect it from aggressive external environmental conditions.

RUBBER DAMPERS (outdoor unit)

To install under the unit to avoid transmission of vibrations to the floor where unit is installed, while unit is operating.

COMPRESSOR ACOUSTIC JACKET (outdoor unit)

Each compressor is fitted with a compressor acoustic jacket this provides attenuation of the compressor noise that radiates from the unit when in operation.

KIT LOW NOISE

With this kit, each compressor is fitted with a compressor acoustic jacket and also includes proportional pressure control, which through a special regulation, decrease the fan speed, and provides attenuation of sound level.

SMOKE DETECTOR

Located downstream of the filter, the ionic head of the smoke detector can detect any type of smoke. In this case it would initiate shutdown sequence the unit, fully close the return air damper and open the fresh air damper up to 100% and send an alarm signal to the unit.

R-407C REFRIGERANT FACTORY PRECHARGED (outdoor unit)

This option includes service valves and R-407C refrigerant charged in outdoor unit (for 0 meters of connection lines).

SERVICE VALVES (outdoor unit)

The unit is fitted with gas and liquid service valves, in order to make easier installation and maintenance operations.

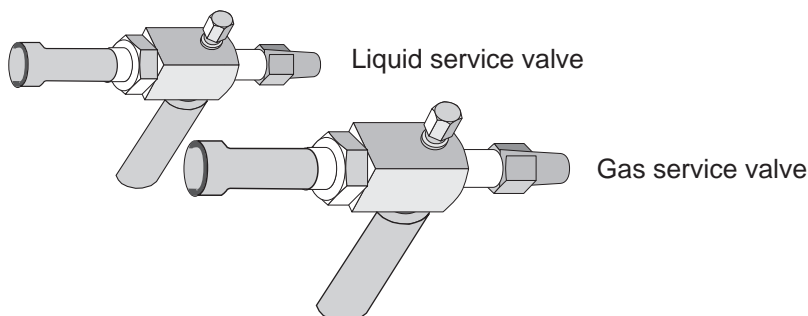

OPTIONS

FREECOOLING

1.- DEFINITION

FREE-COOLING is a saving system in the Cold cycle, this makes the unit take air from the outside to take advantage of its energy, this system acting as a first cold stage.

It is a saving energy system that's why many countries regulations recommended and others put under an obligation to install a freecooling system with the unit.

2.- TYPES OF FREECOOLING

According to outside air parameters which have to be measured, the types are:

- **Thermostatic freecooling:**

Measures and compares the outside air temperature with the temperature of the room that has to be conditioned.

- **Enthalpic freecooling:**

Measures and compares the outside air enthalpy with the return air enthalpy from the room that has to be conditioned.

The enthalpy measures temperature and humidity of air.

3.- COMPONENTS OF FREECOOLING

The main components are:

-Electronic control and accessories: Their function is to detect the outside and indoor air conditions through the probes, deciding when freecooling should operate.

-The servomotor and system transmission: They manage the opening and closing of dampers.

- Adjustable dampers.

-Mixing section: Where outside and return air are mixed.

Also an extra fan is available, which applies an additional static pressure on the suction and return air duct.

For more details about components and drawings see pages 52 to 55.

4.- OPERATION

The control compares the values of temperature/enthalpy between outside air and room air through the probes, if it is a negative difference and the security elements allow (discharge temperature probes) then the control acts over the servomotor, which produces the opening of the outside damper and close the return one, entering cool outside air to the room.

The damper regulation is proportional.

If indoor air demand is not great, could be enough only the freecooling to condition the room, if the air demand is greater it is possible need the freecooling working and the unit working on different cooling mode stages.

5.- THERMOSTAT TERMINAL

Depends on the type of freecooling selected, the thermostat and the electrical box supplied with the unit will be different.

With thermostatic freecooling the thermostat supplied has the same characteristics than the one supplied with the standard unit, except because the one for the freecooling is a programmable one.

With enthalpic freecooling the terminal is different than the one supplied with the unit VFC version, its principal characteristics are: OFF, COOL, HEAT, AUTOMATIC.

THERMOSTAT FOR THERMOSTATIC FREECOOLING

Thermostatic freecooling is supplied with sensor incorporated inside the thermostat. Remote duct and ambient sensor are available as an option.

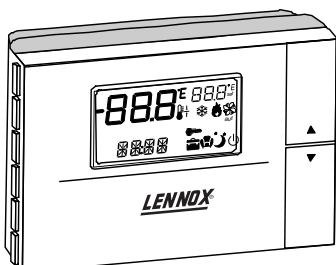

THERMOSTAT FOR ENTHALPIC FREECOOLING

Enthalpic freecooling is supplied with duct sensor. Remote ambient sensor and sensor incorporated inside the thermostat are available as an option.

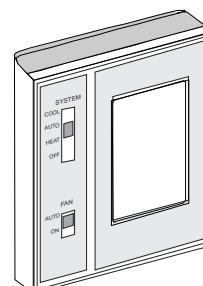

OPTIONS

FREECOOLING

6.- SUPPLY AND INSTALLATION

The freecooling system could be supplied mounted or loose.

Configuration of freecooling supply :



SM: Mixing section

SR: Extra fan section

UI: Indoor unit.

UE: Outdoor unit.

The electrical box for the enthalpic freecooling is supplied apart, and has to be fixed by the installer.

7.- FREECOOLING WITH EXTRA FAN

If an extra static pressure is required on the return air duct, the freecooling should add an extra fan section.

This extra fan section, include a discharge damper.

The operation dampers for this freecooling with extra fan is as follow:

As much as the air intake damper opens, that much the by-pass damper closes and the discharge air damper opens, for the air return suction (see drawing in page 52).

This means that at the same time reach a free cooled of the room, the discharge or return air and the air of the room gets removable.

The consumption of the extra fan by unit is:

MODELS		24E	32E	38E	48D	64D	76D	86D
POWER (Kw)		1,4	1,8	2	2,8	3,6	4	5
MAXIMUM CURRENT (A)	230 / III	4,3	6,2	6,2	8,8	12,5	12,5	20,6
	400 / III	2,5	3,6	3,6	5,1	7,2	7,2	11,9

OPTIONS

FEEECOOLING

Extra fan performances for each models are:

		24E					32E						
AIR FLOW		R.P.M.	M ³ /H	3900	4300	4700	5100	R.P.M.	M ³ /H	4750	5250	5750	6000
PULLEY POSITION	PULLEY CLOSED	1010	145*	115*	70*	35*		1140	160*	80*	35*	0*	
	1 TURN	955	105*	70*	35*	0*		1070	110*	40*	0*	—	
	2 TURNS	900	85*	33*	0*	—		995	60*	0*	—	—	
	3 TURNS	845	50*	5*	—	—		920	10*	—	—	—	

		38E					48D						
AIR FLOW		R.P.M.	M ³ /H	5800	6400	7000	7300	R.P.M.	M ³ /H	7800	8600	9400	10200
PULLEY POSITION	PULLEY CLOSED	890	210*	183*	145*	125*		1010	320*	300*	280*	●	
	1 TURN	840	170*	140*	104*	85*		955	275*	250*	230*	185*	
	2 TURNS	790	130*	95*	45*	35*		900	235*	210*	180*	130*	
	3 TURNS	740	85*	60*	20*	0*		845	195*	150*	130*	85*	

		64D					76D						
AIR FLOW		R.P.M.	M ³ /H	9500	10500	11500	12000	R.P.M.	M ³ /H	11600	12800	14000	14600
PULLEY POSITION	PULLEY CLOSED	1010	275*	245*	185*	155*		890	200*	175*	140*	120*	
	1 TURN	955	220*	175*	130*	105*		840	160*	135*	100*	90*	
	2 TURNS	900	175*	130*	75*	55*		790	120*	85*	50*	35*	
	3 TURNS	845	125*	85*	30*	20*		740	75*	50*	10*	0*	

		86D					
AIR FLOW		R.P.M.	M ³ /H	13000	14500	16000	17500
PULLEY POSITION	PULLEY CLOSED	1055	330*	290*	240*	170*	
	1 TURN	1010	280*	245*	190*	120*	
	2 TURNS	965	245*	210*	155*	90*	
	3 TURNS	920	210*	170*	100*	45*	

(*) AVAILABLE STATIC PRESSURE PA

● WRONG STATUS ON ACCOUNT OF MOTOR POWER LIMIT.

NOTE: The unit leaves factory with pulley two turns opened.

OPTIONS

FREECOOLING

8.- SELECTION OF THE UNIT AND FREECOOLING SYSTEM

There are different types of freecooling system, different possibilities of dampers installations, and it could be supplied mounted or loose.

In order to provide the customer the needed one, fill in the following table and send it to the order department:

INSTALLER COMPANY NAME: _____ CONTACT PERSON NAME: _____
 TEL.: _____ Fax _____ e-mail _____

ATTENTION TO : Lennox Refac S.A. CONTACT PERSON NAME: _____
 TEL.: _____ Fax _____ e-mail _____

ORDER NUMBER: _____

A- Select the unit needed: split or multi-split:

(The freecooling will be supplied mounted on the indoor unit, except for the freecooling with extra fan on models 76D-86D, which is supplied loose).

Split Multi-split

C.-Select the type of thermostatic or enthalpic freecooling and the sensor for freecooling management.

Thermostatic freecooling supplied with sensor incorporated inside the thermostat; Enthalpic freecooling supplied with duct sensor. (If the humidity conditions where the unit is going to be install have relevance, is convenient to install an enthalpic freecooling)

Thermostatic <input type="checkbox"/> Remote ambient sensor <input type="checkbox"/> Remote duct sensor <input type="checkbox"/>	Enthalpic <input type="checkbox"/> Remote ambient sensor <input type="checkbox"/> Sensor incorporated at the thermostat <input type="checkbox"/>
---	---

D.- Select if you need extra fan with the freecooling

With extra fan Without extra fan

E.-Select the dampers configuration for the freecooling, as following. (In order to be adapted to the ducts of the installation)

E.1- Dampers position of the dampers on for freecooling WITHOUT extra fan:

The drawings are an upper view of the indoor unit and freecooling

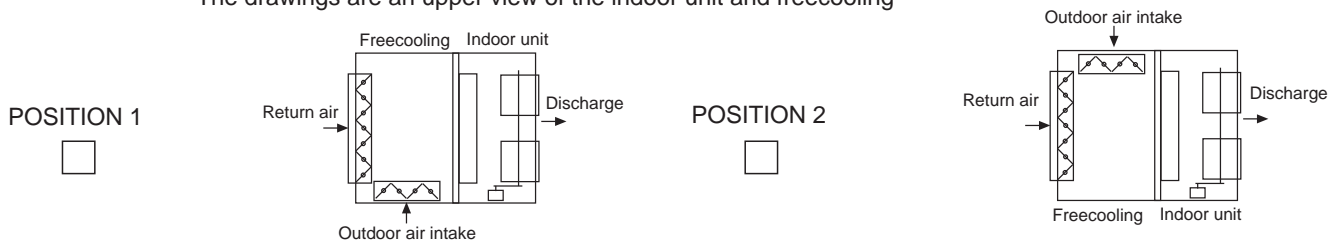

E.2- Dampers position of the dampers on for freecooling WITH extra fan:

The drawings are an upper view of the indoor unit and freecooling

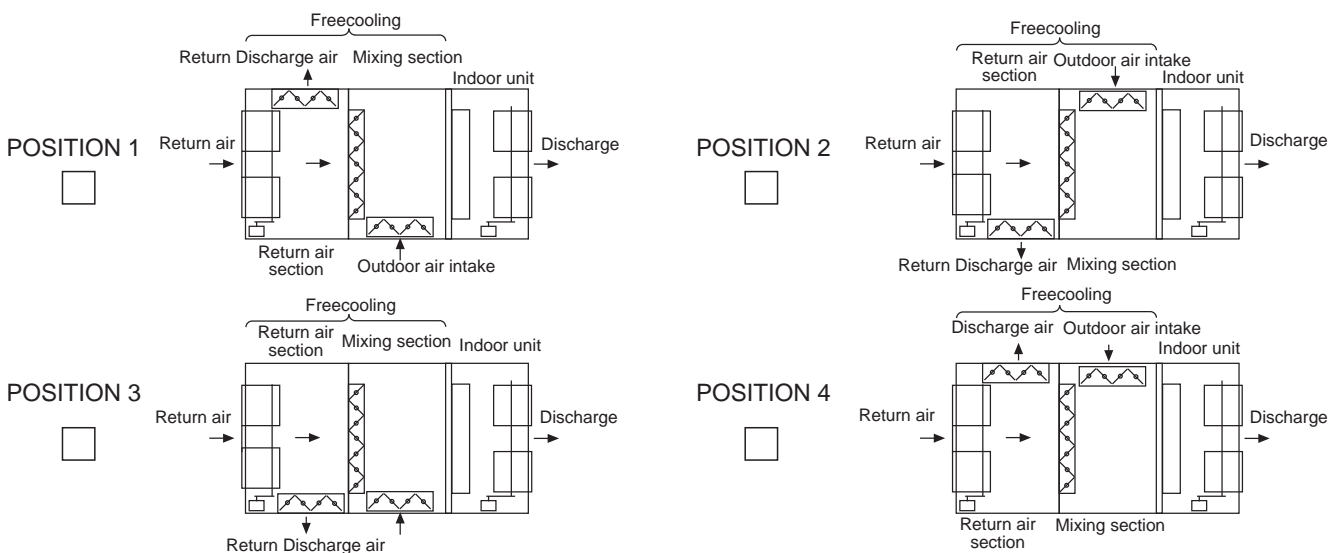

OPTIONS

FREECOOLING

OUTLINE FOR ENTHALPIC FREECOOLING WITHOUT EXTRA FAN

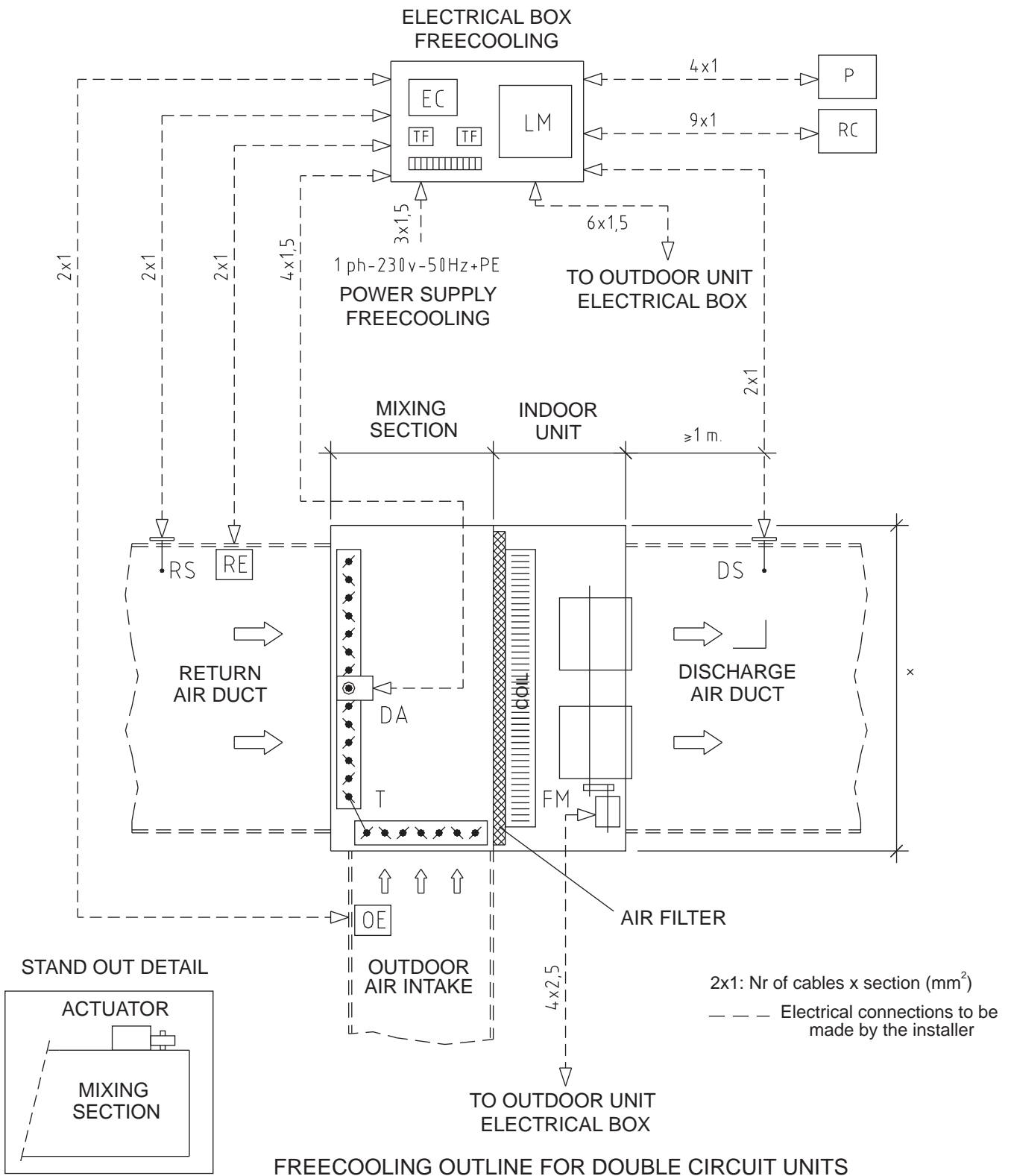

P - Potentiometer
 EC - Enthalpy measure
 LM - Logic module
 TF - Transformer

RC - Remote controller
 RE - Return Enthalpy sensor
 RS - Return Temperature sensor
 DS - Discharge Temperature sensor

DA - Damper Actuator
 FM - Discharge fan motor
 OE - Outside enthalpy sensor
 T - Transmission

OPTIONS

FREECOOLING

OUTLINE FOR ENTHALPIC FREECOOLING WITH EXTRA FAN

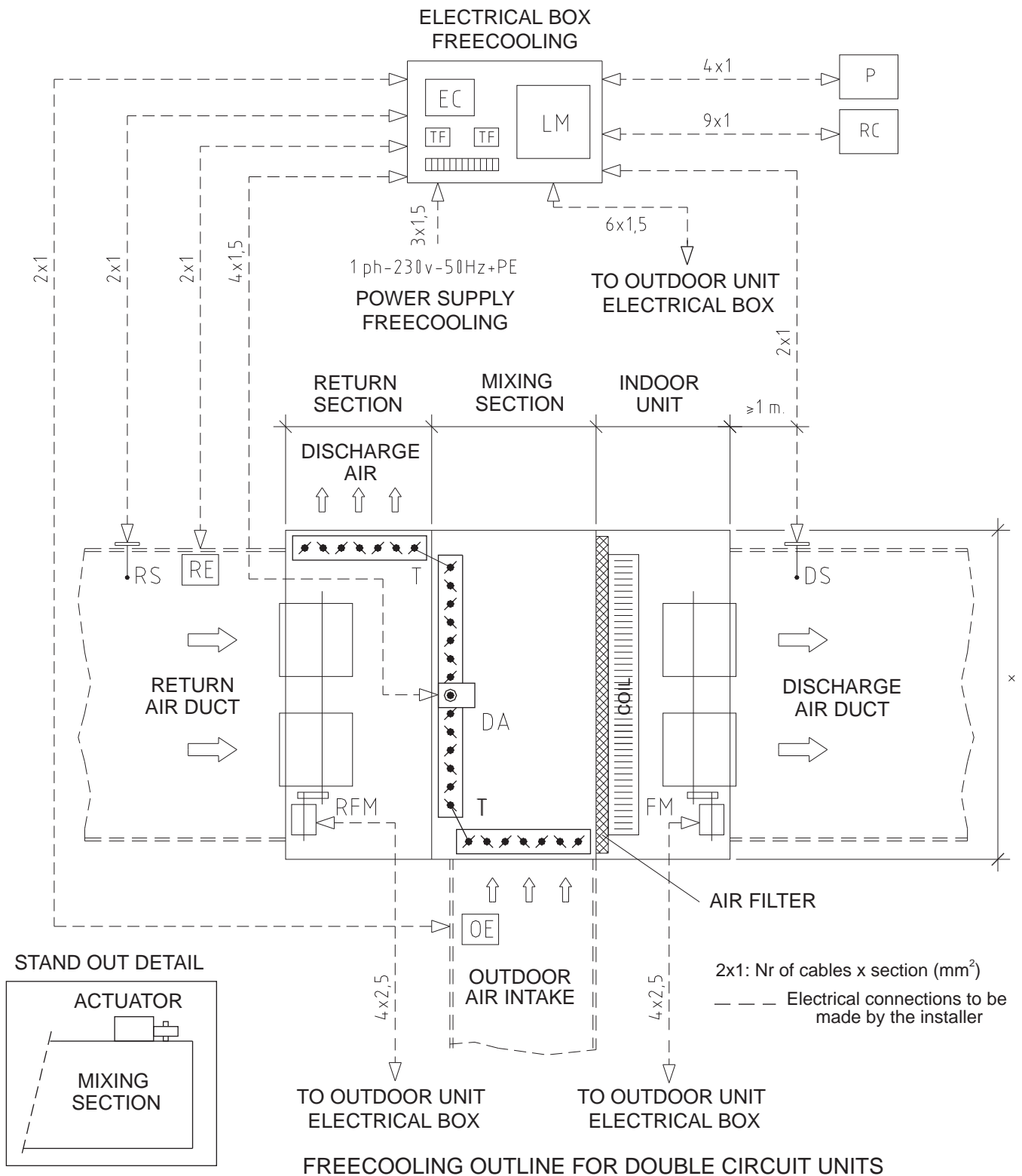

P - Potentiometer
EC - Enthalpy measure
LM - Logic module
TF - Transformer

RC - Remote controller
RE - Return Enthalpy sensor
RS - Return Temperature sensor
DS - Discharge Temperature sensor

DA - Damper Actuator
RFM - Return fan motor
FM - Discharge fan motor
OE - Outside enthalpy sensor
T - Transmission

OPTIONS

FREECOOLING

OUTLINE FOR THERMOSTATIC FREECOOLING WITHOUT EXTRA FAN

ELECTRICAL BOX
OUTDOOR UNIT

ELECTRICAL BOX FREECOOLING

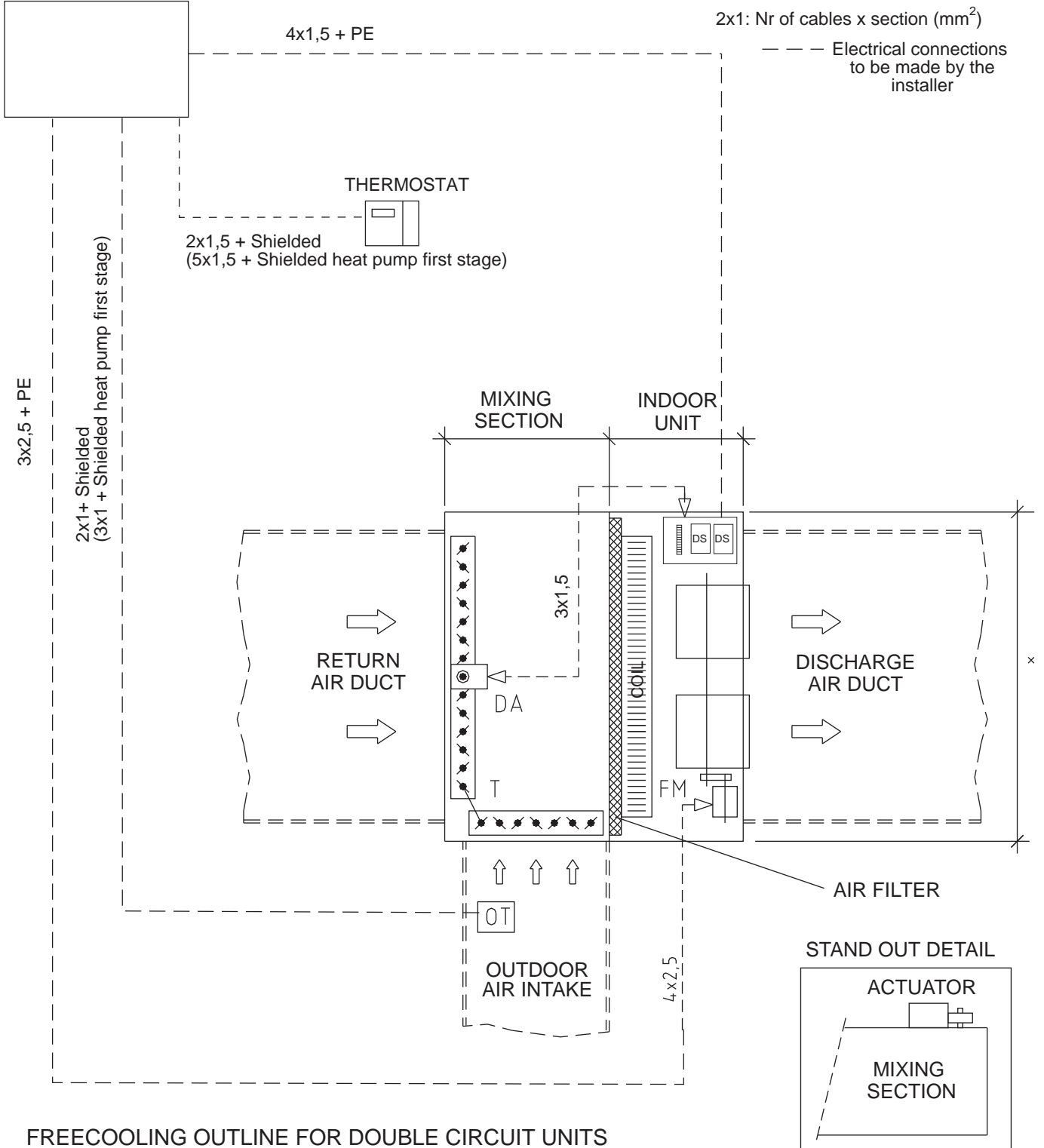

FREECOOLING OUTLINE FOR DOUBLE CIRCUIT UNITS

- DS - Discharge Temperature sensor
- DA - Damper Actuator
- FM - Discharge fan motor
- OT - Outside temperature sensor
- T - Transmission

OPTIONS

FREECOOLING

OUTLINE FOR THERMOSTATIC FREECOOLING WITH EXTRA FAN

ELECTRICAL BOX
OUTDOOR UNIT

ELECTRICAL BOX FREECOOLING

2x1: Nr of cables x section (mm²)

--- Electrical connections to be made by the installer

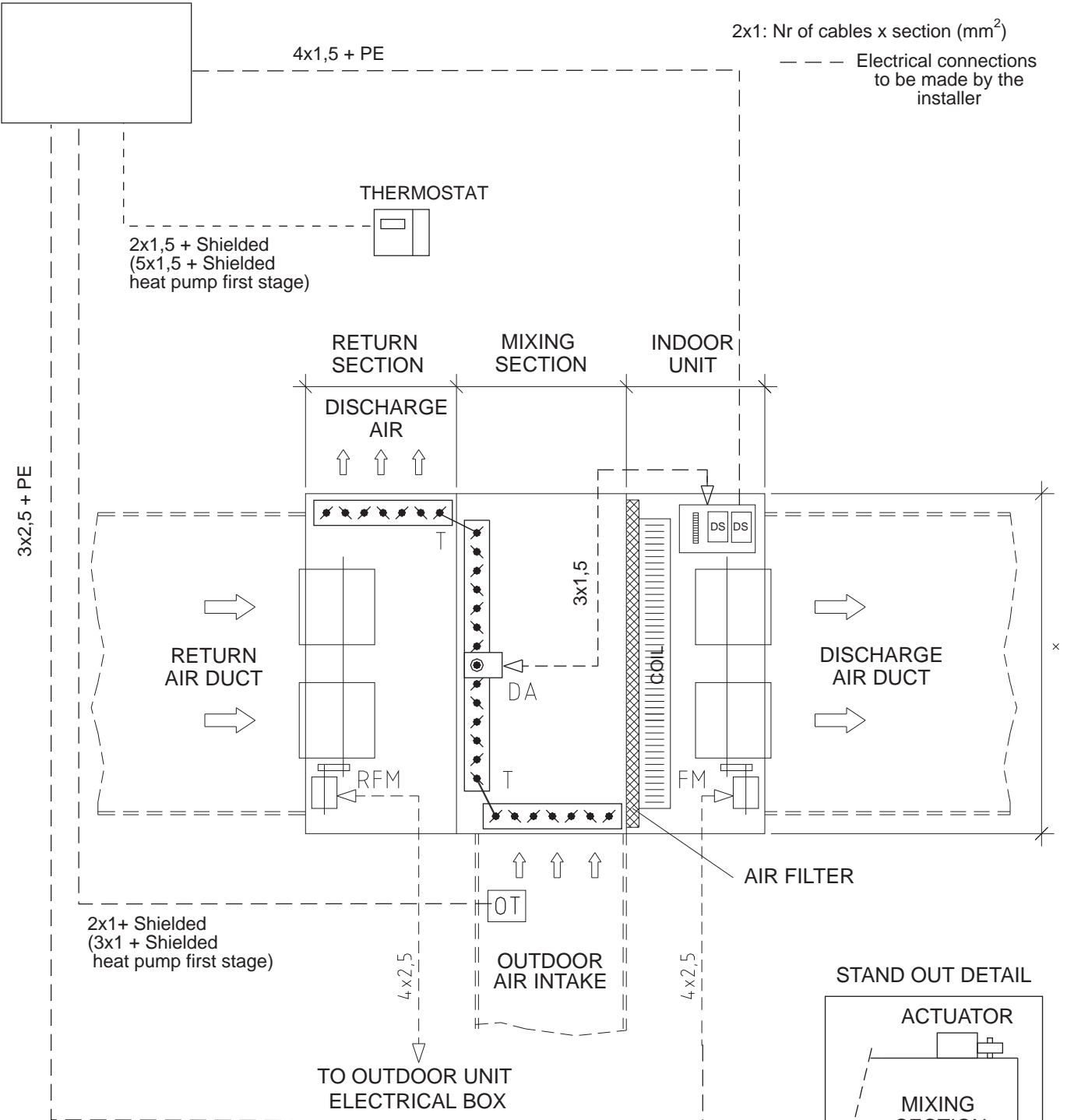

FREECOOLING OUTLINE FOR DOUBLE CIRCUIT UNITS

- DS - Discharge Temperature sensor
- DA - Damper Actuator
- RFM - Return fan motor
- FM - Discharge fan motor
- OT - Outside temperature sensor
- T - Transmission

OPTIONS

FREECOOLING

DIMENSIONS FREECOOLING WITHOUT EXTRA FAN

MODELS 24E-32E-38E

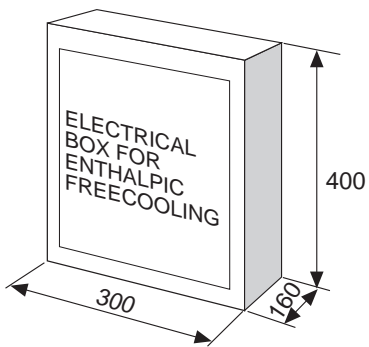
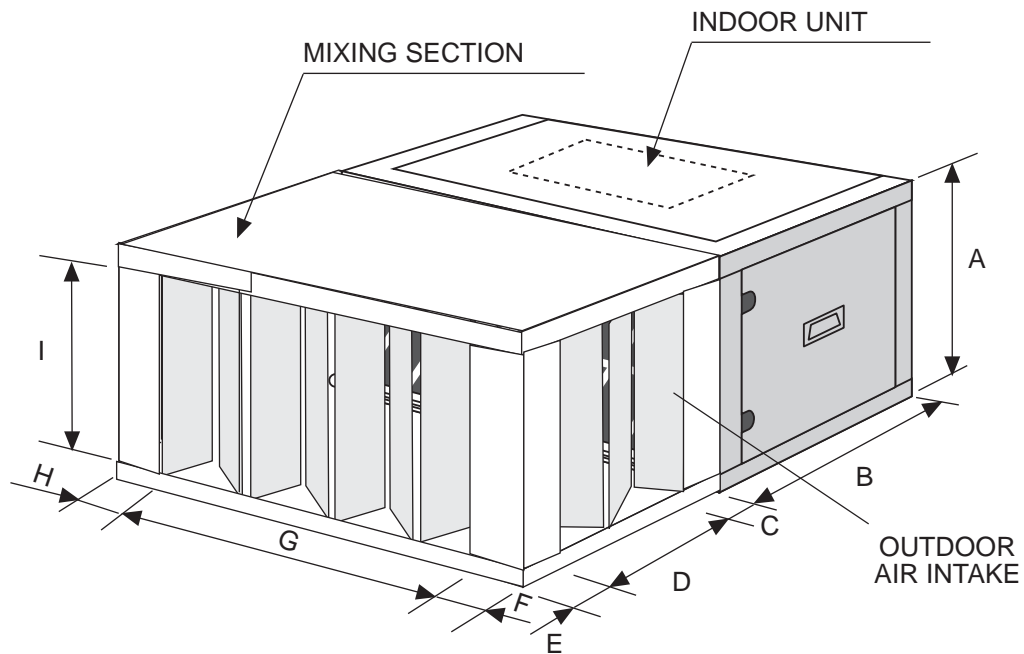

Electrical box for freecooling is supplied loose inside the mixing section. Fix by the installer.

The damper position can be different than the picture shows. See drawings.

	MODELS 24-32	MODEL 38
A	640	640
B	749	749
C	98	73,5
D	750	750
E	52	76,5
F	222	222
G	750	876
H	222	222
I	499	500
WEIGHTS Kg (*)	100	100

(*) Add to the unit's weight.

OPTIONS

FREECOOLING

DIMENSIONS FREECOOLING WITHOUT EXTRA FAN

MODELS 48-64D-76D

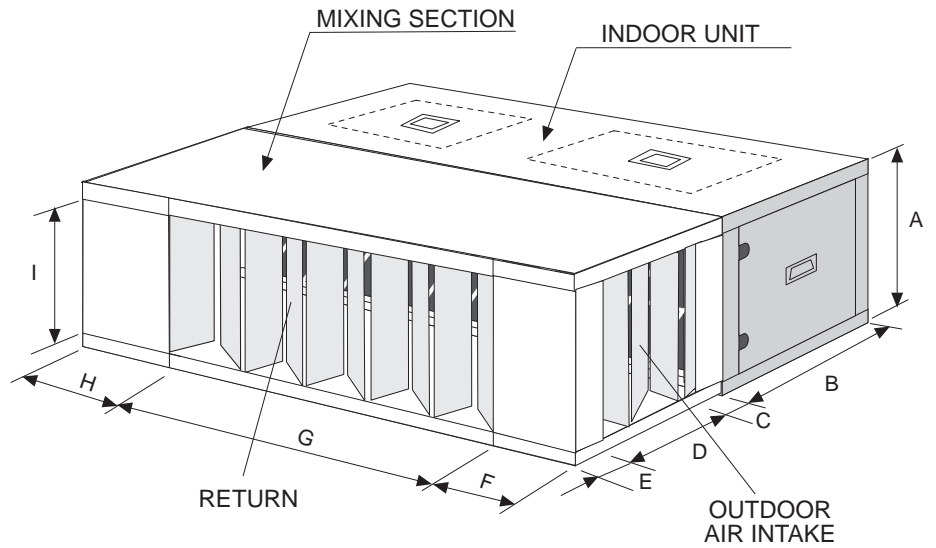

MODELS 86D

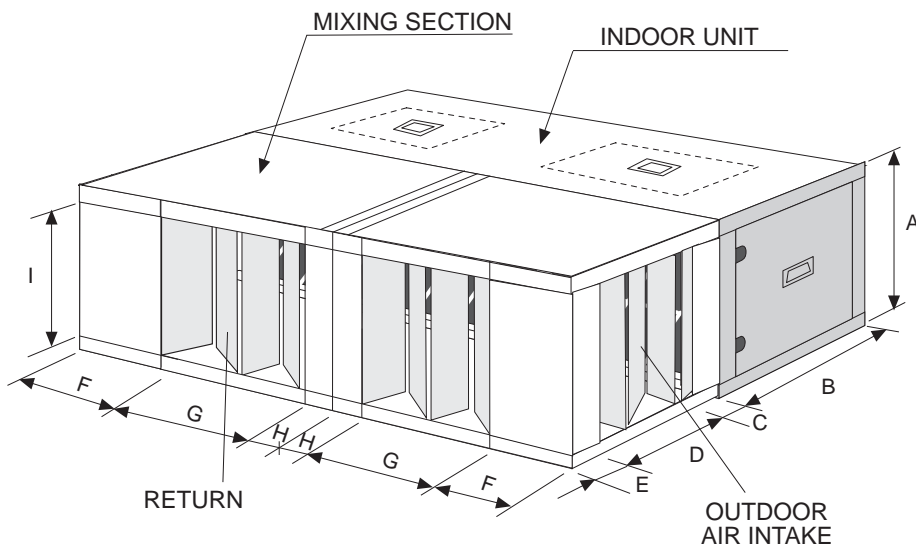

The damper position can be different than the picture shows.
See drawings.

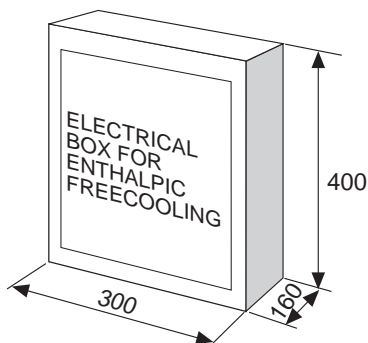

Electrical box for freecooling is supplied loose inside the mixing section.
Fix by the installer.

	MODELS 48-64	MODELS 76	MODELS 86
A	640	640	640
B	750	750	750
C	100,5	100,5	50
D	749	749	1000
E	50,5	50,5	150
F	250	312,5	233
G	1750	1875	1125
H	250	312,5	93
I	499	499	550
WEIGHTS Kg (*)	130	135	250

(*) Add to the unit's weight.

OPTIONS

FREECOOLING

DIMENSIONS FREECOOLING WITH EXTRA FAN

MODELS 24E-32E-38E

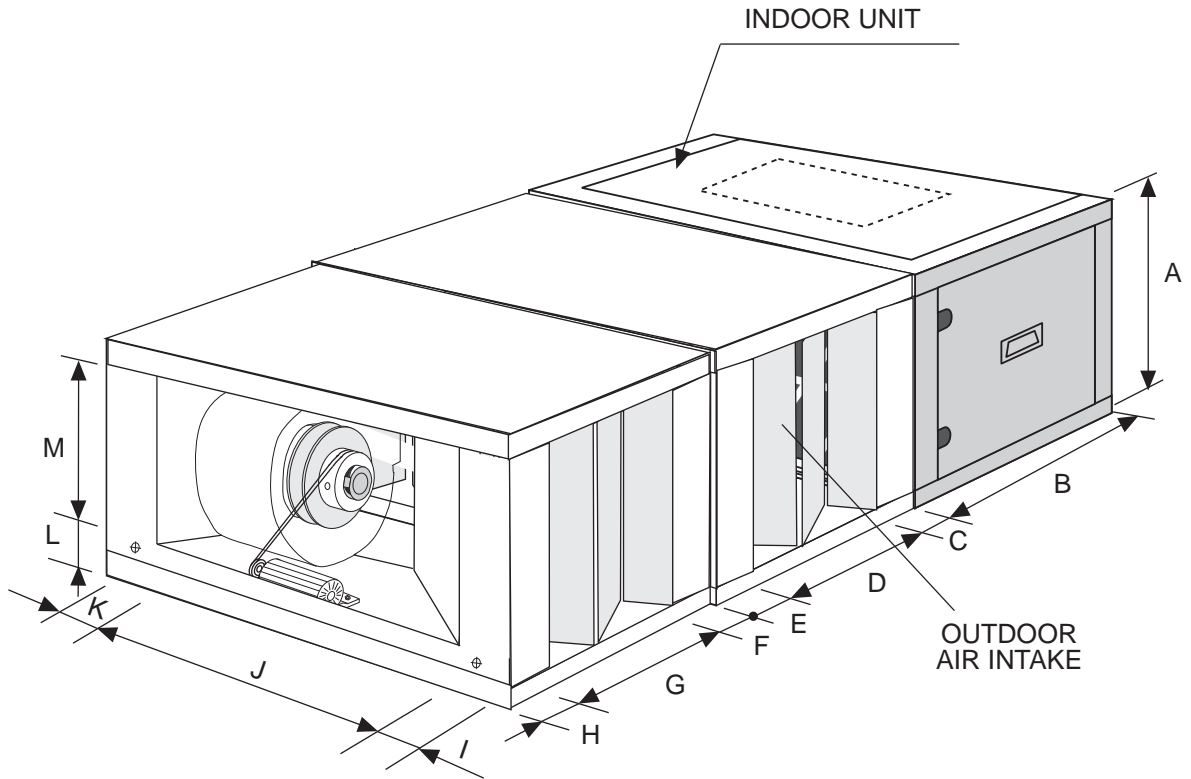

The damper position can be different than the picture shows. See drawings.

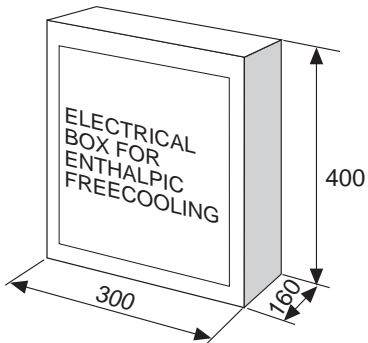

Electrical box for freecooling is supplied loose inside the mixing section. Fix by the installer.

	MODELS 24-32	MODEL 38
A	640	640
B	749	749
C	98	73,5
D	750	750
E	52	76,5
F	48	48
G	750	750
H	102	102
I	186	186
J	822	948
K	186	186
L	96,5	96,5
M	500	500
WEIGHTS Kg (*)	24: 120 32: 125	125

(*) Add to the unit's weight.

OPTIONS

FREECOOLING

DIMENSIONS FREECOOLING WITH EXTRA FAN

MODELS 48D-64D-76D

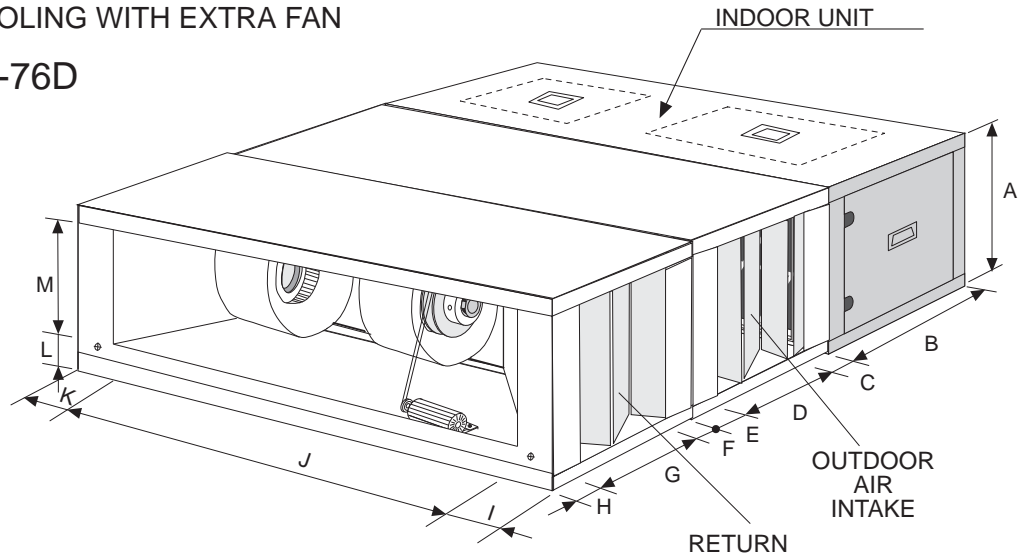

MODELS 86D

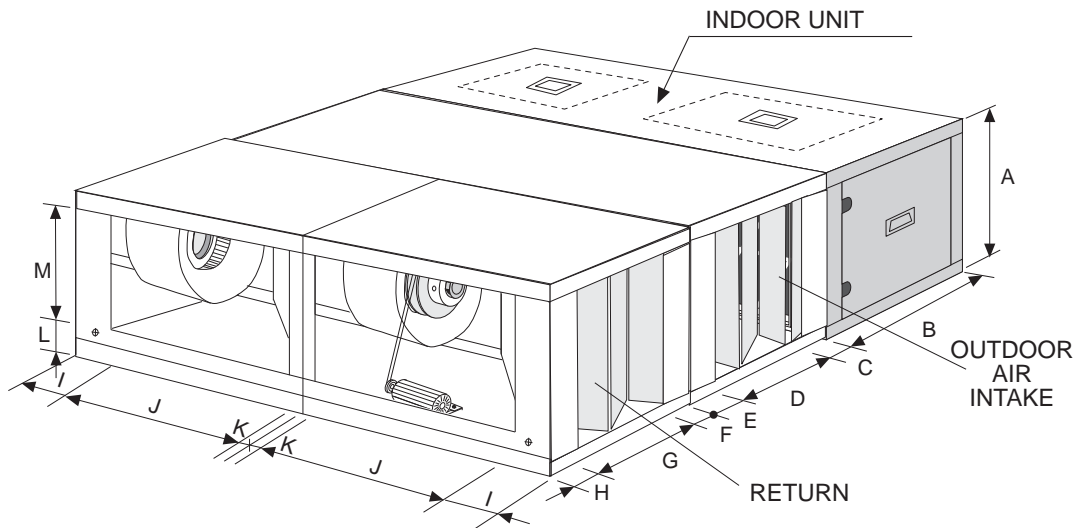

The damper position can be different than the picture shows. See drawings.

	MODELS 48-64	MODELS 76	MODELS 86
A	640	640	640
B	750	750	750
C	100,5	100,5	50
D	749	749	1000
E	50,5	50,5	150
F	48	48	45
G	750	750	1010
H	102	102	145
I	186	311	191,5
J	1878	1878	1204,5
K	186	311	15
L	96,5	96,5	88
M	500	500	500
WEIGHTS Kg (*)	195	200	320

(*) Add to the unit's weight.

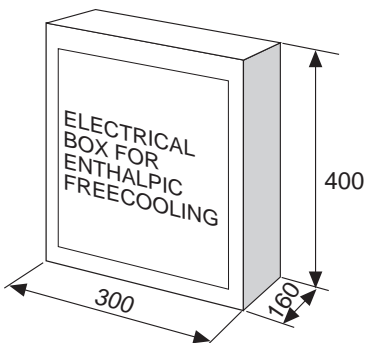

Electrical box for freecooling is supplied loose inside the mixing section. Fix by the installer.

OPERATION GUIDE

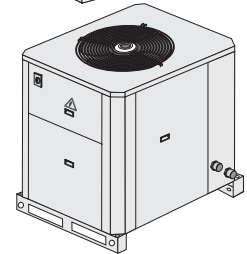
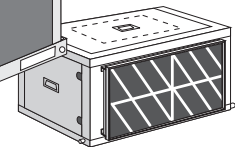
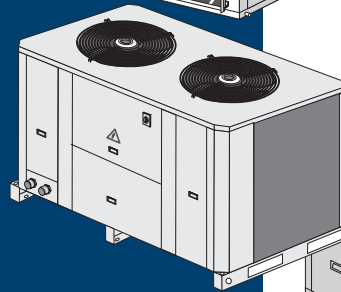
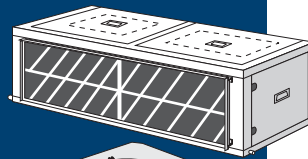

SPLIT SYSTEM

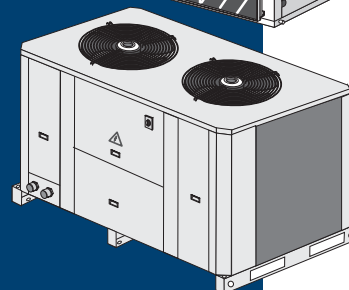
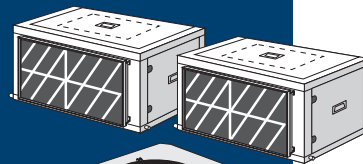

MULTI-SPLIT SYSTEM

PROVIDING **GLOBAL SYSTEM** SOLUTIONS

**AIRCOOLAIR
ANCK / ANHK**

GREAT BRITAIN,
IRELAND:

LENNOX INDUSTRIES LTD
tél. : + 44 1604 59 9400
fax : + 44 1604 594200
e-mail : marketing @ lennoxind.com

BELGIUM :

LENNOX BENELUX N.V./S.A.
tél. : + 32 3 633 30 45
fax : + 32 3 633 00 89
e-mail : info @ lennoxbenelux.com

CZECH REPUBLIC :

JANKA LENNOX
tél. : + 420 2 510 88 111
fax : + 420 2 579 10 393
e-mail : janka @ janka.cz

FRANCE :

LENNOX FRANCE
tél. : + 33 4 72 23 20 20
fax : + 33 4 78 20 07 76
e-mail : accueil @ lennoxfrance.com

GERMANY:

LENNOX DEUTSCHLAND GmbH
tél. : + 49 69 42 0979 0
fax : + 49 69 42 0979 40
e-mail : info @ lennoxdeutschland.com

NETHERLANDS :

LENNOX BENELUX B.V.
tél. : + 31 33 2471 800
fax : + 31 33 2459 220
e-mail : info @ lennoxbenelux.com

POLAND :

LENNOX POLSKA SP z o.o.
tél. : + 48 22 832 26 61
fax : + 48 22 832 26 62
e-mail : lennoxpolska @ inetia.pl

PORTUGAL :

LENNOX CLIMATIZAÇÃO LDA.
tél. : + 351 22 998 33 70
fax : + 351 22 998 33 79
e-mail : marketing @ lennoxportugal.com

RUSSIA :

LENNOX DISTRIBUTION MOSCOW
tél. : + 7 095 246 07 46
fax : + 7 502 933 29 55
e-mail : lennox.dist.moscow @ co.ru

SLOVAKIA :

LENNOX SLOVAKIA
tél. : + 421 7 44 88 92 16
fax : + 421 7 44 88 16 88

SPAIN:

LENNOX REFAC S.A.
tél. : + 34 902 400 405
fax : + 34 91 542 84 04
e-mail : marketing @ lennox-refac.com

UKRAINE :

LENNOX DISTRIBUTION KIEV
tél. : + 380 44 213 14 21
fax : + 380 44 213 14 21
e-mail : jankauk @ uct.kiev.ua

OTHER EUROPEAN COUNTRIES,
AFRICA,
MIDDLE-EAST :

LENNOX DISTRIBUTION
tél. : + 33 4 72 23 20 14
fax : + 33 4 72 23 20 28
e-mail : marketing @ lennoxdist.com



LENNOX[®]

WWW.LENNOXEUROPE.COM