Congratulations you have made a wise choice with the purchase of your Lennox KNA unit. This product has been designed, assembled and supplied in one of our world class manufacturing facilities and we feel sure that it will meet your expectations. Lennox an international organisation with world wide distribution takes pride in supplying you with this product.

TABLE OF CONTENTS

CONTENTS	PAGE
• PRODUCT RANGE	2
• GENERAL DESCRIPTION	3
• SPECIFICATIONS	4
• ELECTRICAL CONNECTIONS	5
• CAPACITY TABLE	6
• OPERATION LIMITS	7
• REFRIGERANT CONNECTIONS	8-9
• DIMENSIONS	10
• TROUBLESHOOTING	11
• MAINTENANCE	11
• POINTS TO KEEP IN MIND	12
• NOTES	13-14

PRODUCT RANGE

MODEL	V / Ph / 50 Hz	MAX. COOLING CAPACITY W	MAX. INPUT POWER kW
KNA 5EK	230 V - 3Ph	14100	5.29
	400 V - 3Ph		
KNA 7EK	230 V - 3Ph	17800	7.00
	400 V - 3Ph		
KNA 8EK	230 V - 3Ph	21950	8.00
	400 V - 3Ph		
KNA 10EK	230 V - 3Ph	28300	10.26
	400 V - 3Ph		
KNA 15EK	230 V - 3Ph	35950	13.70
	400 V - 3Ph		
KNA 15DK	230 V - 3Ph	36300	14.23
	400 V - 3Ph		
KNA 17DK	230 V - 3Ph	43000	16.26
	400 V - 3Ph		
KNA 20DK	230 V - 3Ph	55400	21.30
	400 V - 3Ph		
KNA 30DK	230 V - 3Ph	68200	27.85
	400 V - 3Ph		

This model is prepared only and exclusively to work with refrigerant R407C

CAUTION: Do not use any other refrigerant

The refrigerant R407-C is a mixture of other three refrigerants that behave as pure compounds. This fact makes that the operations of installation; service and maintenance must be special, for the next operations:

SYSTEM EVACUATION

Evacuating the system is critical for proper operation of the unit, vacuum must be done until the absolute pressure does not rise above 0.225 mm Hg, since the compressor oil high hygroscopic degree can cause corrosion in some metallic materials.

REFRIGERANT CHARGING

To maintain the mixture composition, the refrigerant must be charged always in liquid phase. For what it is necessary to have special caution when it is little quantity of refrigerant in the bottle.

LEAKS

If a leak takes place in the system that has produced an important evacuation of the refrigerant charge, instead of recharging the system, it is convenient to eliminate the whole charge completely, the system must be evacuated and charged again or to introduce the charge according to an specified value.

COMPRESSOR OIL

With HCF refrigerant like in the case of R407-C, compressors are used that incorporate ester oil instead of the mineral oil used in compressors that work with HCFC refrigerant, like it is the case of R22.

OPERATION

On a system operated with refrigerant R407-C, during the evaporation phase at constant pressure the temperature increase; and during the condensation phase at constant pressure the temperature decrease a certain value. Consequently the terms "evaporation temperature" and "condensation temperature" should be redefined

GENERAL DESCRIPTION

The KNA-K cooling only unit is an independent vertical outdoor unit; of air to air type, that cools, dehumidifies, and cleans the air of a building by filtering it.

The KNA-K- is designed and manufactured for outdoor installation. However, they may be installed as indoors if adequate provisions are made for sufficient air intake and exhaust. Each unit has been designed to the most exacting standard. The KNA-K- is designed so that the air is pushed in through the coils and discharged vertically.

CASING

Unit chassis is made of electrozinc steel with epoxy painted finish, able to work outdoor under the worst conditions. It incorporates thermal-acoustic insulation.

INTERCHANGERS

Made of copper tubes with aluminium louvered fins. Coils have been designed and manufactured to ensure maximum efficiency.

COMPRESSORS

One or two compressors of the hermetic reciprocating type. Compressors are fully suction-gas cooled and include internal thermal protection and an oil sight glass (depends on model). They are mounted on vibration absorbent blocks both on the inside and outside, statically and dynamically balanced.

Crankcase heater protects against off cycle migration of refrigerant.

FANS

Fans are axial type, with exceptional performance for air flow volumes and sound levels. Fan speed control is present to maintain unit condensing temperature at approximately 40° C. The condensing fan motor speed will increase as the condensing temperature increases.

REFRIGERANT PIPING

Made of welded dehydrated copper pipe with liquid and vapor line service valves. Refrigerant circuit includes muffler in the compressor discharge line, which eliminates noise and pulsation of the discharge line, filter dryer and expansion system. High safety pressure switch, manual reset, to prevent a high pressure in the refrigerant system, which will damage the unit. Low safety pressure switch, automatic reset, to prevent the unit running under too low pressure conditions.

ELECTRIC CIRCUIT

The unit is supplied with an enclosed control panel located inside the unit and easily accessible. It consists of compressor contactor and thermal overload relay and contactor for fan motor.

It also includes a PCB with the following functions:
FOR KNA 5EK-7EK-8EK-10EK-15EK

- Modulating fan speed control
- Anti-cycling provision
- Low ambient temperature start provision
- Temperature cut out for the fan motor
- Connection possibility for two steps compressor start with starting resistance
- LED indicators for low pressure and temperature sensor failure for the fan control circuit.

FOR KNA 15DK-17DK-20DK-30DK

- Anti cycling system to protect the compressor and increase its lifetime, at each compressor shut down, a time delay will de-energise the control circuit for 5 min.
- A selector for operating sequence to choose which compressor is on during first stage and which one is on during second stage, a time delay timer of 30 sec. for activation of second compressor.

OPTIONS

- Main switch
- Circuit breaker and fuses
- General alarm and operating kit (potential free contact)
- Hot gas bypass kit

CHARACTERISTICS

MODEL			KNA 5EK	KNA 7EK	KNA 8EK	KNA 10EK	KNA 15EK	
Cooling capacity	(*)	KW	14.10	17.80	21.95	28.30	35.95	
COMPRESSOR		N° / Type	2/Rec	2/Rec	2/Rec	2/Rec	2/Rec	
CONDENSER COIL								
Net face area		m²	2 x 0.42	2 x 0.42	2 x 0.84	2 x 0.84	2 x 0.84	
Number of rows / fins per inch			3/14	4/14	2/14	3/14	4/14	
FAN Air volume		m³/h	4500	5200	9500	9000	10400	
REFRIGERANT CHARGE R407C		gr	Charged with N₂					
NET WEIGHT		Kg	135	145	220	270	320	
DIMENSIONS								
Height		mm.	870	870	895	895	895	
Length		mm.	800	800	800	800	800	
Depth		mm.	800	800	1600	1600	1600	
PACKAGE DIMENSIONS HxLxD		mm.	1020 x 950 x 845		1070 x 880 x 1685			
REFRIGERANT CONNECTIONS								
Liquid line			5/8"	5/8"	5/8"	5/8"	3/4"	
Suction line			3/4"	7/8"	1 1/8"	1 3/8"	1 3/8"	

MODEL			KNA 15DK	KNA 17DK	KNA 20DK	KNA 30DK
Cooling capacity	(*)	kW	36.30	43.00	55.40	68.20
COMPRESSOR		N° / Type	2/Rec	2/Rec	2/Rec	2/Rec
CONDENSER COIL						
Net face area		m²	2 x 0.88	2 x 0.88	2 x 1.28	2 x 1.28
Number of rows / fins per inch			3/14	4/14	3/14	4/14
FAN Air volume		m³/h	14400	14200	20000	19200
REFRIGERANT CHARGE R407C		gr	Charged with N₂			
NET WEIGHT		Kg	305	350	405	455
DIMENSIONS						
Height		mm	1360	1360	1860	1860
Length		mm	2000	2000	2000	2000
Depth		mm	1000	1000	1000	1000
PACKAGE DIMENSIONS HxLxD		mm	1450 x 2140 x 1230		1950 x 2140 x 1230	
REFRIGERANT CONNECTIONS						
Liquid line			2 x 5/8"	2 x 5/8"	2 x 5/8"	2 x 3/4"
Suction line			2 x 7/8"	2 x 1-1/8"	2 x 1-1/8"	2 x 1-3/8"

(*) Mean evaporating temperature 7°C / Outside air temperature 35° C

Connection lines length 5m

DB: Dry bulb

SPECIFICATIONS

SOUND DATA

MODEL		KNA 5EK	KNA 7EK	KNA 8EK	KNA 10EK	KNA 15EK
Sound level (Lp) (1)	dB(A)	46	48	49	49	51

MODEL		KNA 15DK	KNA 17DK	KNA 20DK	KNA 30DK
Sound level (Lp) (1)	dB(A)	52	53	55	55

(1) Sound level measured to a distance of 5m, free space, directability \pm 3 dB.

ELECTRICAL DATA

MODEL		KNA 5EK	KNA 7EK	KNA 8EK	KNA 10EK	KNA 15EK
Voltage	V/f (50 Hz)	230V- 3Ph / 400V- 3Ph				
Nominal total input power	Kw (*)	5.29	7.00	8.00	10.26	13.70
Max. current input 230 / 400 V	A	23/15	29/23	35/22	43/27	51/36
Starting current 230 / 400 V	A	117/63	135/69	155/79	170/105	208/130

MODEL		KNA 15DK	KNA 17DK	KNA 20DK	KNA 30DK
Voltage	V/f (50 Hz)	230V- 3Ph / 400V- 3Ph			
Nominal total input power	Kw (*)	14.23	16.26	21.30	27.85
Max. current input 230 / 400 V	A	56/34	64/38	82/48	100/60
Starting current 230 / 400 V	A	163/84	187/98	211/129	260/160

(*) Mean evaporating temperature 7°C / Outside air temperature 35°C DB

OPERATING LIMITS

* Air intake temperature into the outdoor unit °C

** Air intake temperature into the indoor unit °C

THE LOW AMBIENT CONTROL IS STANDARD

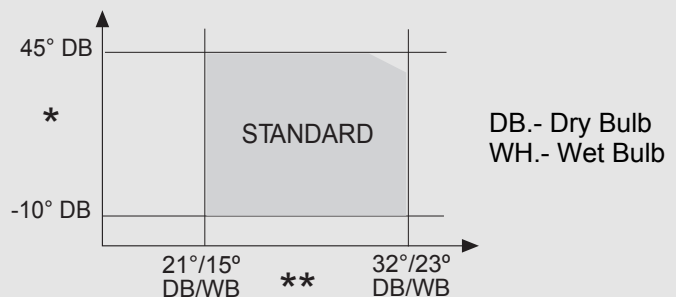

CAPACITIES

		KNA 5 K						KNA 7 K					
(1)		(2) °C						(2) °C					
		0 °C	+2 °C	+4 °C	+6 °C	+8 °C	+10 °C	0 °C	+2 °C	+4 °C	+6 °C	+8 °C	+10 °C
15 °C	(3)	12.57	14.06	15.52	17.04	18.66	20.35	15.89	17.71	19.48	21.31	23.27	25.31
	(4)	4.47	4.66	4.85	5.04	5.23	5.44	5.94	6.18	6.44	6.69	6.95	7.22
20 °C	(3)	12.13	13.44	14.83	16.29	17.84	19.65	15.39	16.98	18.66	20.43	22.30	24.49
	(4)	4.40	4.59	4.79	4.99	5.20	5.06	5.85	6.10	6.36	6.63	6.90	6.72
25 °C	(3)	11.52	12.77	14.10	15.50	17.14	18.31	14.65	16.18	17.79	19.49	21.48	22.89
	(4)	4.40	4.60	4.81	5.02	5.04	5.26	5.85	6.12	6.39	6.67	6.69	6.98
30 °C	(3)	10.87	12.07	13.32	14.79	15.87	16.97	13.87	15.33	16.86	18.66	19.95	21.26
	(4)	4.48	4.69	4.91	5.00	5.23	5.46	5.95	6.24	6.53	6.63	6.94	7.25
35 °C	(3)	10.18	11.31	12.62	13.61	14.59	15.61	13.05	14.43	16.03	17.22	18.40	19.62
	(4)	4.50	4.74	4.92	5.17	5.41	5.67	5.97	6.29	6.53	6.84	7.17	7.51
40 °C	(3)	9.46	10.62	11.51	12.39	13.31	14.24	12.17	13.60	14.67	15.73	16.85	17.96
	(4)	4.62	4.82	5.07	5.33	5.60	5.88	6.12	6.39	6.71	7.05	7.40	7.76
45 °C	(3)	8.80	9.58	10.39	----	----	----	11.37	12.32	----	----	----	----
	(4)	4.68	4.95	5.22	----	----	----	6.19	6.54	----	----	----	----

		KNA 8 K						KNA 10 K					
(1)		(2) °C						(2) °C					
		0 °C	+2 °C	+4 °C	+6 °C	+8 °C	+10 °C	0 °C	+2 °C	+4 °C	+6 °C	+8 °C	+10 °C
15 °C	(3)	19.69	21.97	24.26	26.65	29.21	31.89	25.49	28.40	31.22	34.17	37.31	40.60
	(4)	6.72	6.93	7.14	7.35	7.57	7.79	8.47	8.76	9.05	9.35	9.65	9.96
20 °C	(3)	18.94	20.98	23.16	25.46	27.90	30.77	24.65	27.17	29.87	32.70	35.70	39.23
	(4)	6.71	6.93	7.16	7.39	7.62	7.34	8.45	8.76	9.07	9.39	9.72	9.40
25 °C	(3)	17.69	19.91	21.99	24.18	26.77	28.64	23.43	25.85	28.42	31.12	34.31	36.58
	(4)	6.79	7.03	7.27	7.51	7.48	7.72	8.56	8.89	9.23	9.57	9.55	9.91
30 °C	(3)	16.91	18.77	20.74	23.04	24.75	26.50	22.13	24.44	26.87	29.73	31.80	33.91
	(4)	6.98	7.24	7.51	7.55	7.82	8.10	8.80	9.17	9.54	9.63	10.01	10.41
35 °C	(3)	15.81	17.56	19.60	21.15	22.71	24.33	20.76	22.93	25.47	27.36	29.26	31.21
	(4)	7.07	7.36	7.57	7.86	8.15	8.46	8.93	9.34	9.64	10.05	10.47	10.90
40 °C	(3)	14.65	16.45	17.82	19.20	20.66	22.13	19.30	21.55	23.23	24.91	26.96	28.47
	(4)	7.29	7.52	7.83	8.15	8.47	8.81	9.23	9.57	10.00	10.44	10.91	11.38
45 °C	(3)	13.57	14.78	16.03	17.31	----	----	17.95	19.45	20.89	----	----	----
	(4)	7.41	7.74	8.08	8.43	----	----	9.41	9.87	10.34	----	----	----

KNA 15 K	(1)	(2) °C					
		0 °C	+2 °C	+4 °C	+6 °C	+8 °C	+10 °C
15 °C	(3)	32.07	35.68	39.15	42.79	46.66	50.70
	(4)	11.44	11.85	12.26	12.69	13.12	13.56
20 °C	(3)	31.17	34.29	37.62	41.11	44.81	49.16
	(4)	11.39	11.81	12.25	12.70	13.16	12.74
25 °C	(3)	29.77	32.78	35.95	39.28	43.22	46.00
	(4)	11.51	11.96	12.42	12.89	12.87	13.36
30 °C	(3)	28.27	31.13	34.13	37.67	40.20	42.78
	(4)	11.81	12.30	12.79	12.92	13.43	13.96
35 °C	(3)	26.64	29.34	32.49	34.80	37.12	39.50
	(4)	11.94	12.48	12.88	13.41	13.98	14.55
40 °C	(3)	24.89	27.69	29.75	31.81	33.98	36.16
	(4)	12.32	12.75	13.31	13.89	14.49	15.11
45 °C	(3)	12.52	13.11	----	----	----	----
	(4)	23.25	25.08	----	----	----	----

DB - Dry bulb

- (1) AIR INLET TEMPERATURE
OUTDOOR UNIT °C DB
- (2) MEAN EVAPORATING
TEMPERATURE
- (3) COOLING CAPACITY IN KW
- (4) TOTAL POWER
COMSUPTION IN KW

CAPACITY TABLE

COOLING CAPACITY IN kW

KNA-15DK

KNA-17DK

(1)		(2) °C						(2) °C					
		0 °C	+2 °C	+4 °C	+6 °C	+8 °C	+10 °C	0 °C	+2 °C	+4 °C	+6 °C	+8 °C	+10 °C
15 °C	(3)	32.18	35.89	39.49	43.25	47.25	51.43	38.70	43.28	47.75	52.42	57.41	62.64
	(4)	11.99	12.49	12.99	13.50	14.03	14.57	13.50	13.96	14.42	14.89	15.36	15.84
20 °C	(3)	31.17	34.41	37.87	41.49	45.32	49.82	37.32	41.31	45.57	50.05	54.81	60.40
	(4)	11.82	12.32	12.87	13.40	13.95	13.57	13.50	13.98	14.46	14.96	15.48	14.95
25 °C	(3)	29.70	32.82	36.12	39.59	43.68	46.59	35.37	39.19	43.24	47.51	52.54	56.18
	(4)	11.84	12.38	12.94	13.49	13.55	14.13	13.67	14.19	14.71	15.23	15.19	15.73
30 °C	(3)	28.12	31.11	34.25	37.93	40.60	43.32	33.30	36.93	40.76	45.25	48.55	51.93
	(4)	12.06	12.64	13.24	13.45	14.05	14.69	14.06	14.62	15.19	15.31	15.89	16.50
35 °C	(3)	26.46	29.29	32.58	35.03	37.49	40.01	31.12	34.53	38.50	41.50	44.52	47.64
	(4)	12.12	12.76	13.26	13.90	14.56	15.24	14.23	14.86	15.31	15.94	16.58	17.24
40 °C	(3)	24.70	27.63	29.84	32.03	34.34	36.66	28.82	32.32	34.98	37.64	40.48	43.30
	(4)	12.45	12.97	13.64	14.35	15.06	15.79	14.69	15.20	15.85	16.55	17.24	17.96
45 °C	(3)	23.08	25.05	27.08	---	---	---	26.68	29.02	31.44	---	---	---
	(4)	12.61	13.30	14.02	---	---	---	14.95	15.64	16.36	---	---	---

KNA-20DK

KNA-30DK

(1)		(2) °C						(2) °C					
		0 °C	+2 °C	+4 °C	+6 °C	+8 °C	+10 °C	0 °C	+2 °C	+4 °C	+6 °C	+8 °C	+10 °C
15 °C	(3)	50.19	55.89	61.39	67.15	73.27	79.67	61.82	68.67	75.21	82.05	89.29	96.84
	(4)	17.52	18.15	18.79	19.43	20.11	20.80	23.05	23.89	24.95	25.92	26.94	27.98
20 °C	(3)	48.52	53.45	58.71	64.22	70.05	76.92	60.00	65.90	72.13	78.67	85.55	93.66
	(4)	17.47	18.14	18.83	19.52	20.25	19.62	22.96	23.91	24.92	25.93	27.01	26.26
25 °C	(3)	46.10	50.83	55.83	61.08	67.28	71.67	57.24	62.88	68.80	75.02	82.33	87.41
	(4)	17.70	18.41	19.15	19.88	19.89	20.66	23.18	24.18	25.24	26.30	26.40	27.51
30 °C	(3)	43.53	48.03	52.75	58.31	62.30	66.38	54.25	59.61	65.19	71.78	76.38	81.07
	(4)	18.21	18.98	19.79	20.01	20.84	21.70	23.77	24.87	25.98	26.34	27.50	28.72
35 °C	(3)	40.80	45.04	49.98	53.62	57.27	61.03	51.04	56.07	61.93	66.15	70.34	74.63
	(4)	18.46	19.31	19.98	20.86	21.76	22.69	24.02	25.22	26.12	27.33	28.55	29.87
40 °C	(3)	37.92	42.29	45.55	48.78	52.20	55.62	47.60	52.79	56.58	60.30	---	---
	(4)	19.08	19.78	20.72	21.68	22.66	23.68	24.75	25.73	26.98	28.27	---	---
45 °C	(3)	35.25	38.13	---	---	---	---	44.37	---	---	---	---	---
	(4)	19.44	20.41	---	---	---	---	25.13	---	---	---	---	---

(1) AIR INLET TEMPERATURE OUTDOOR UNIT °C DB

(2) MEAN EVAPORATING TEMPERATURE

(3) COOLING CAPACITY IN kW

(4) TOTAL POWER COMSUPTION IN kW

DB - Dry bulb

Connection lines lenght 5 m

OPERATION LIMITS

Suction temperature range compresor °C: -4/+10

Air inlet temperature range condenser °C: -10/+45

REFRIGERANT CONNECTIONS

To locate outdoor and indoor unit, refer to the following information:

- L : Height between both units
- 1 = Refrigerant liquid line
- 2 = Refrigerant suction line

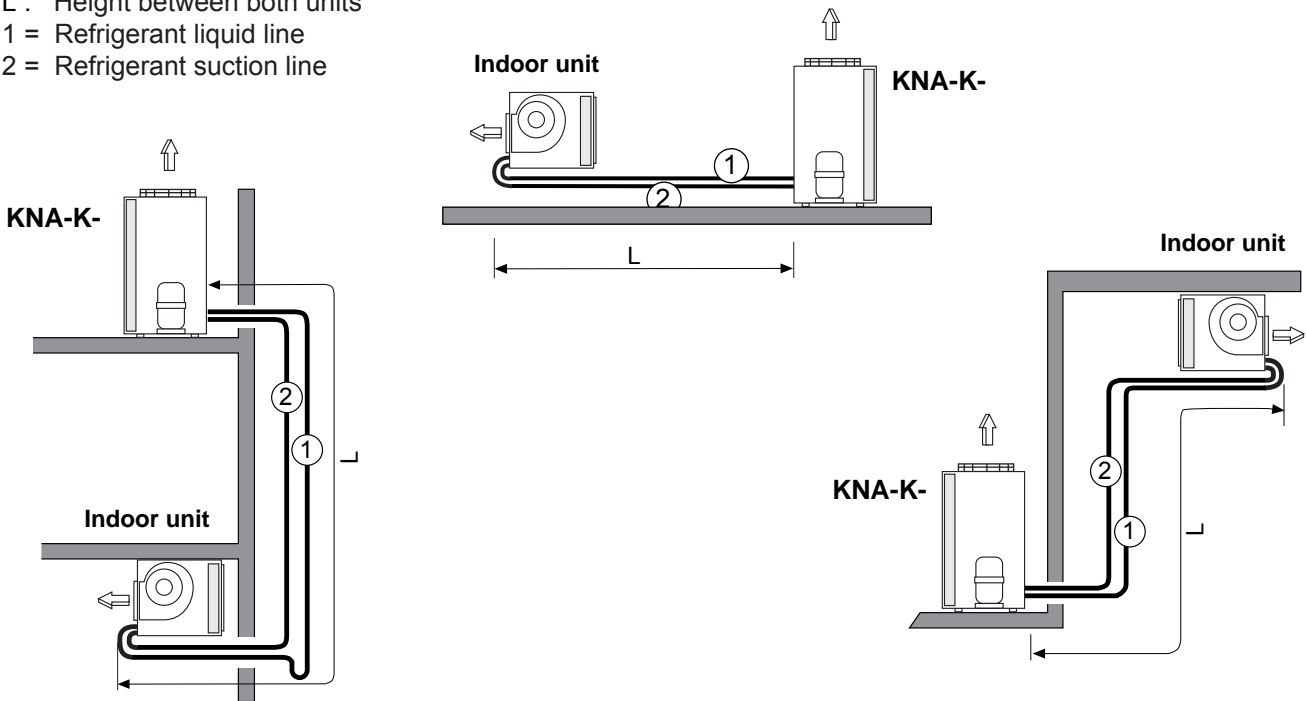

MODEL KNA		5EK	7EK	8EK	10EK	15EK
Refrigerant connections	Liquid pipe	1 x 5/8"	1 x 5/8"	1 x 5/8"	1 x 5/8"	1 x 3/4"
	Suction pipe	1 x 3/4"	1 x 7/8"	1 x 1-1/8"	1 x 1-3/8"	1 x 1-3/8"
Max. difference en height		15	15	15	15	15
Max. distances L (vertical + horizontal)		20	25	20	20	25
Max. number of bends		12	12	12	12	12

MODEL KNA		15DK	17DK	20DK	30DK
Refrigerant connections	Liquid pipe	2x5/8"	2x5/8"	2x5/8"	2x3/4"
	Suction pipe	2x7/8"	2x1-1/8"	2x1-1/8"	2x1-3/8"
Max. difference en height		15	15	15	15
Max. distances L (vertical + horizontal)		25	25	25	25
Max. number of bends		12	12	12	12

NOTE: THE SUCTION LINE MUST BE INSULATED

For other positions and longer lengths, consult the Lennox Technical Support Department for application assistance.

The following data will be obtained from that estimation:

- Pipe dimensions
- Syphon suction
- Insulation
- Refrigerant charge

Unit factory charged with nitrogen (N₂)

CHARGE OF REFRIGERANT TO BE ADDED BY EVERY METER OF LINE LENGTH

MODEL KNA	5EK	7EK	8EK	10EK	15EK	15DK	17DK	20DK	30DK
(gr)	185	186	191	196	296	2x220	2x225	2x225	2x340

KNA 5 K

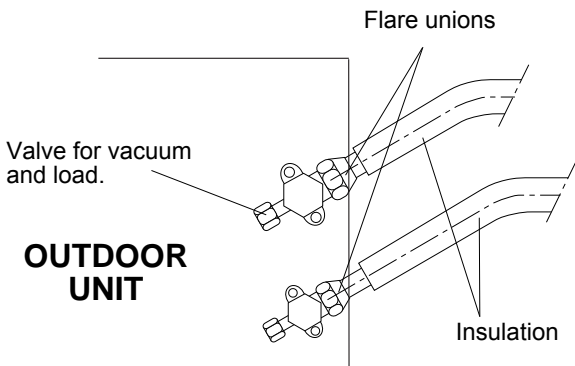

JOINING TUBING TO THE KNA

With the valves closed on the outdoor unit, unscrew the flare nuts, removing all the protective hoods. Introduce the flare nuts in the final corresponding union tubes, previously isolated. Make the thread union of the tubes in valves and couplings using the keys, as shown in the picture.

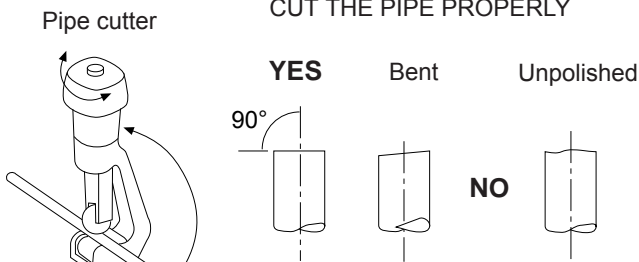

MAKE A CORRECT FLARE END

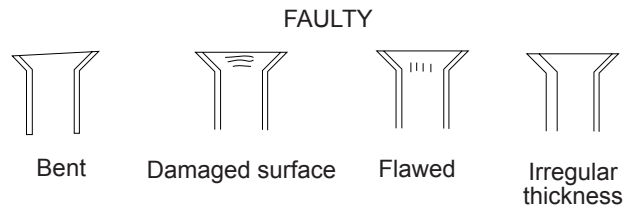

AVOID FROM METALIC DUST ENTERING INTO THE PIPE

CLEAN THE EDGES

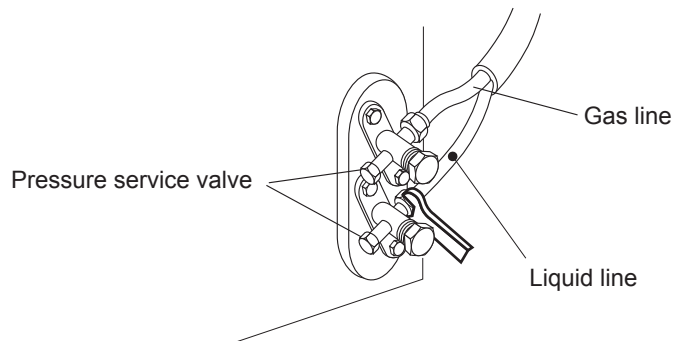
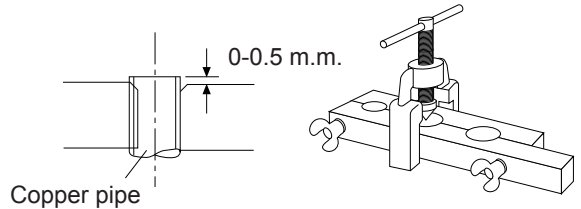
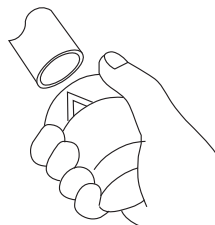

REFRIGERANT CONNECTIONS

KNA 7 K

INSTALLATION OF THE REFRIGERANT TUBING

The KNA is equipped with one shot quick connect couplings and set of counter couplings adaptors completes the delivery.

Use these adaptors to connect the interconnection lines between the air handling unit and the KNA.

The connection adaptors have different line size; the larger is for the suction line and the smaller is for the liquid line. The end of the adaptor with the hex nut and gauge port is to be attached to the KNA.

The suction line should be insulated to prevent sweating and heat gain

JOINING TUBING TO THE KNA

- Remove the protective cap from coupling to be joined
- lightly coat the interior parts of the couplings with refrigerant oil
- Turn the coupling halves a few turns by hand being sure that they line up.
- Tighten up the coupling with aid 2 spanners then tighten an additional 1/4 turn to assure metal seal has seated properly.
- This is necessary to assure a leakproof joint.
- In order to prevent loss refrigerant, tightening should be done quickly. Check for leaks using a soap solution

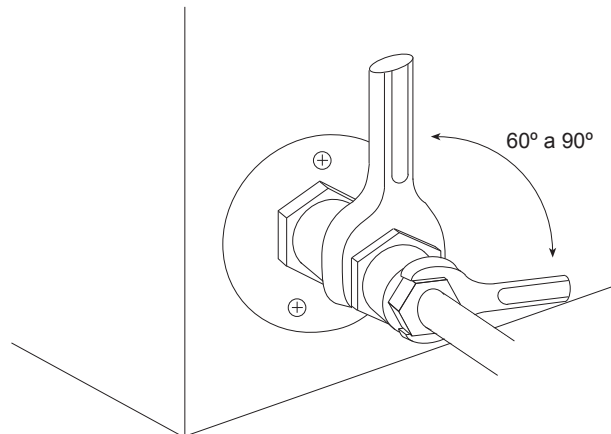

KNA 15DK-17DK-20DK-30DK

LIQUID & VAPOR LINE SERVICE VALVES

The liquid line and vapor line service valves and service ports are accessible inside of the outdoor unit. With these valves the refrigerant circuit can be isolated, the indoor unit from the outdoor unit.

-To open/close liquid or vapor line service valves:

-Remove cap

-Use an adjustable wrench, to open it turn stem out counterclockwise, to close it turn stem clockwise.

-Service valve operation:

Service valve position	Stem position	Circuit communicated	Circuit no communicated
Closed	Inside service valve	B-C	A-B
Opened	Out service valve	A-B	B-C

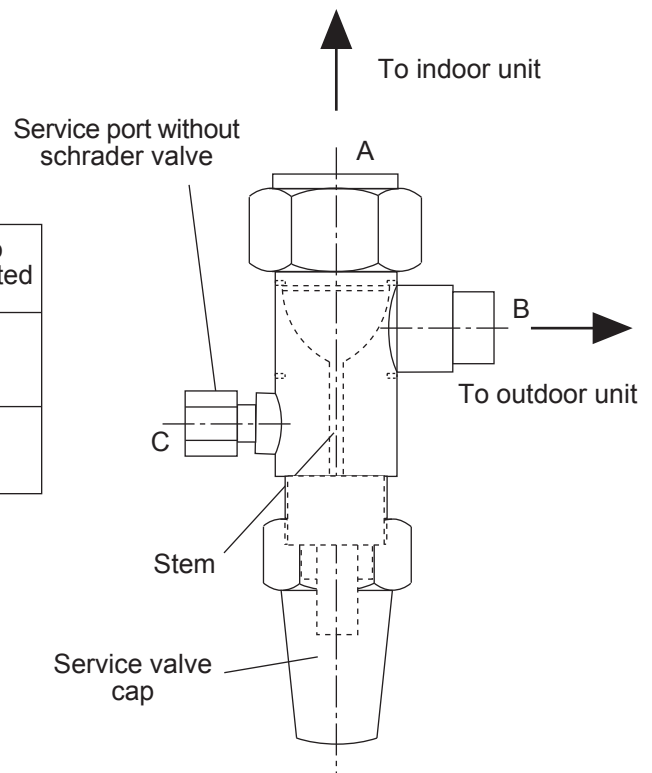

ELECTRICAL CONNECTIONS

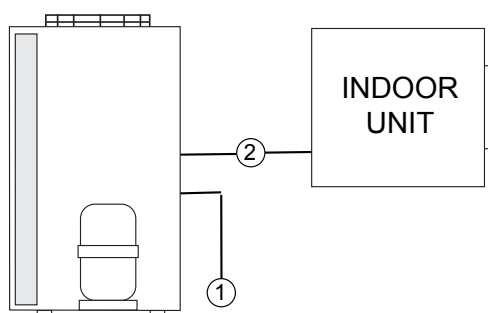

KNA-K-

- ① Power supply
- ② Connection indoor unit with outdoor unit
(This connection depends on the indoor unit motor you will connect with).

Operating voltage limits:

230V-1Ph: min. 198 V, max. 264 V
400V-3Ph: min. 342 V, max. 440 V

POWER SUPPLY WIRING

This equipment must be installed in accordance with national regulations. A suitable means of disconnecting all supply poles must be provided in the power supply wiring. The power supply must incorporate suitably rated fused or circuit breaker protection.

ELECTRIC WIRING DIAGRAM

For electrical connection refer to wiring diagram in the unit.

MODELS	VOLTAGE	NUMBER OF WIRES x SECTION
		①
KNA 5EK	230 V / 3Ph	4x6 mm ²
	400 V / 3Ph	5x4 mm ²
KNA 7EK	230 V / 3Ph	4x10 mm ²
	400 V / 3Ph	5x4 mm ²
KNA 8EK-10EK	230 V / 3Ph	4x10 mm ²
	400 V / 3Ph	5x6 mm ²
KNA 15EK	230 V / 3Ph	4x16 mm ²
	400 V / 3Ph	5x10 mm ²
KNA 15DK	230 V / 3Ph	4x25 mm ²
	400 V / 3Ph	5x10 mm ²
KNA 17DK	230 V / 3Ph	4x25 mm ²
	400 V / 3Ph	5x10 mm ²
KNA 20DK	230 V / 3Ph	4x35 mm ²
	400 V / 3Ph	5x16 mm ²
KNA 30DK	230 V / 3Ph	4x50 mm ²
	400 V / 3Ph	5x25 mm ²

DIMENSIONS

KNA 5EK-7EK

FLOOR MOUNTED

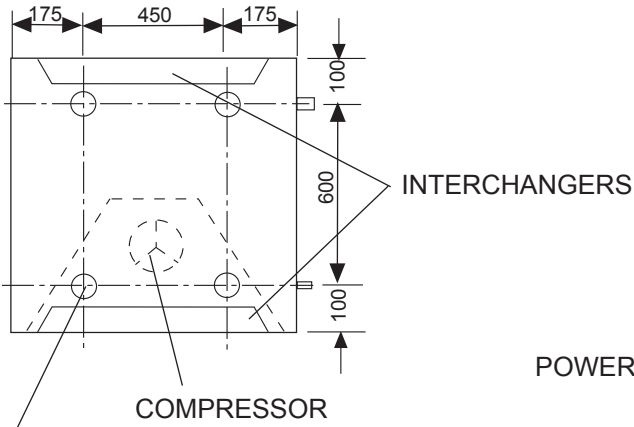

DRILL HOLE Ø10MM

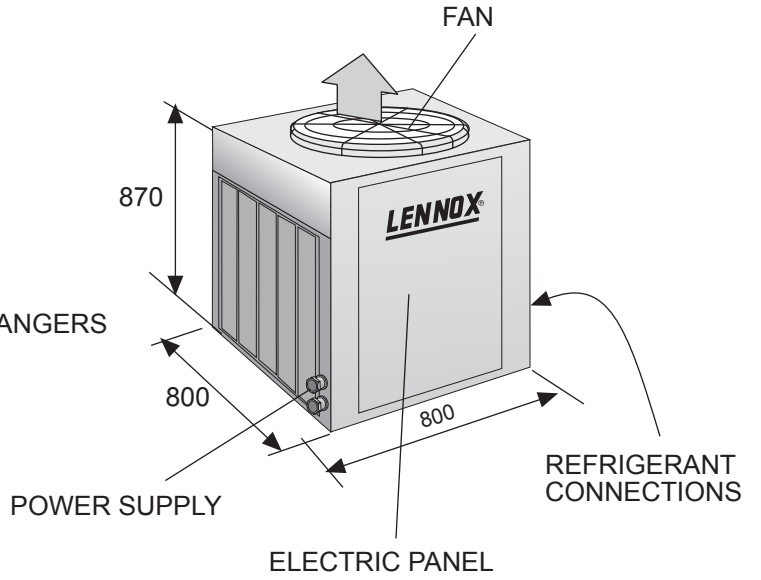

KNA 8EK-10EK-15EK

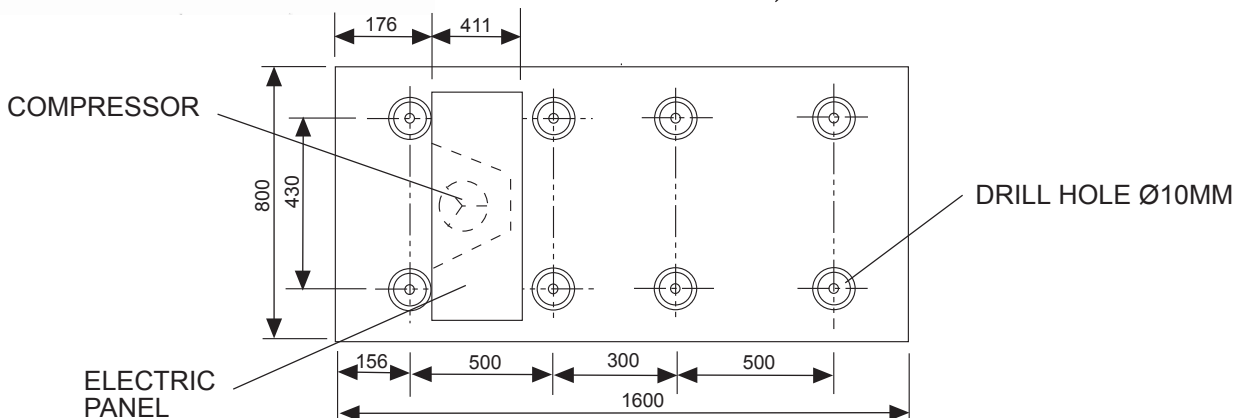
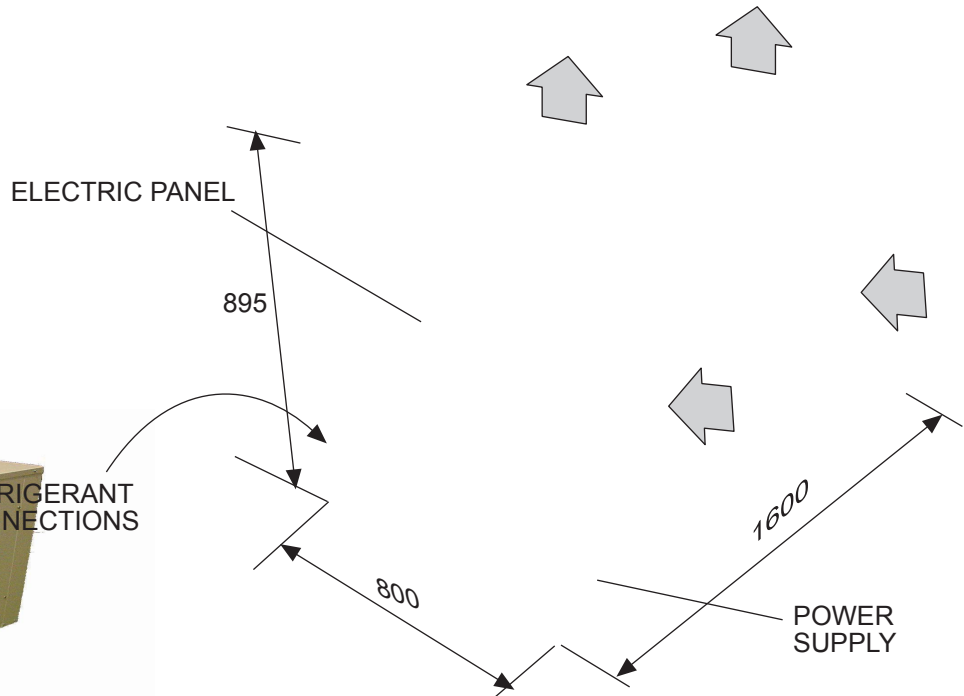

DIMENSIONS

KNA 15DK / 17DK / 20DK / 30DK

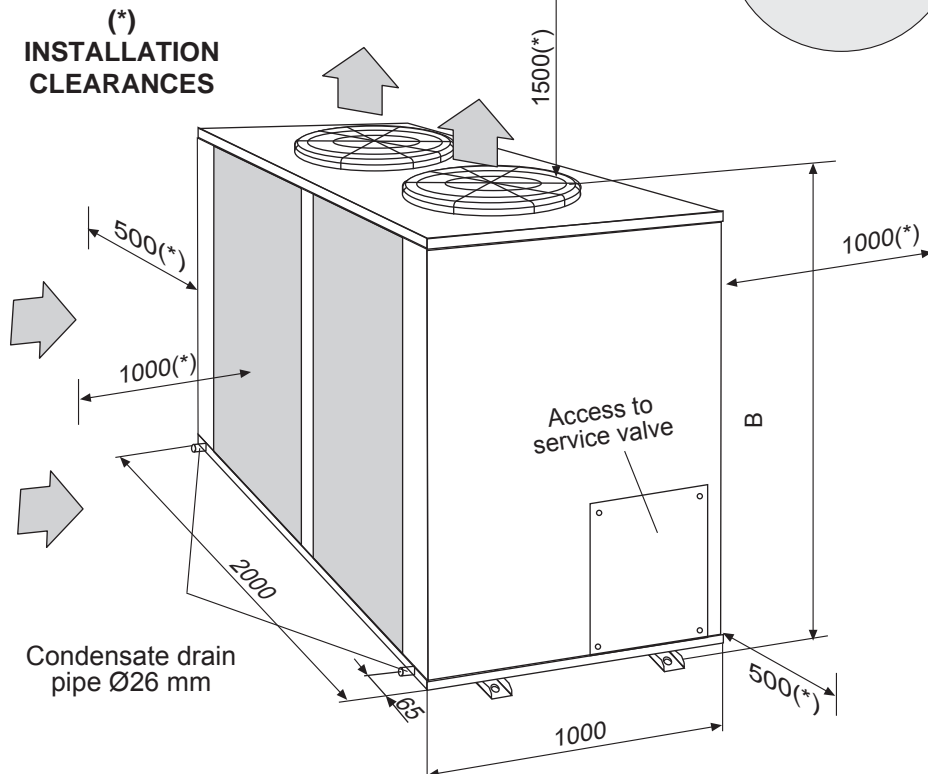
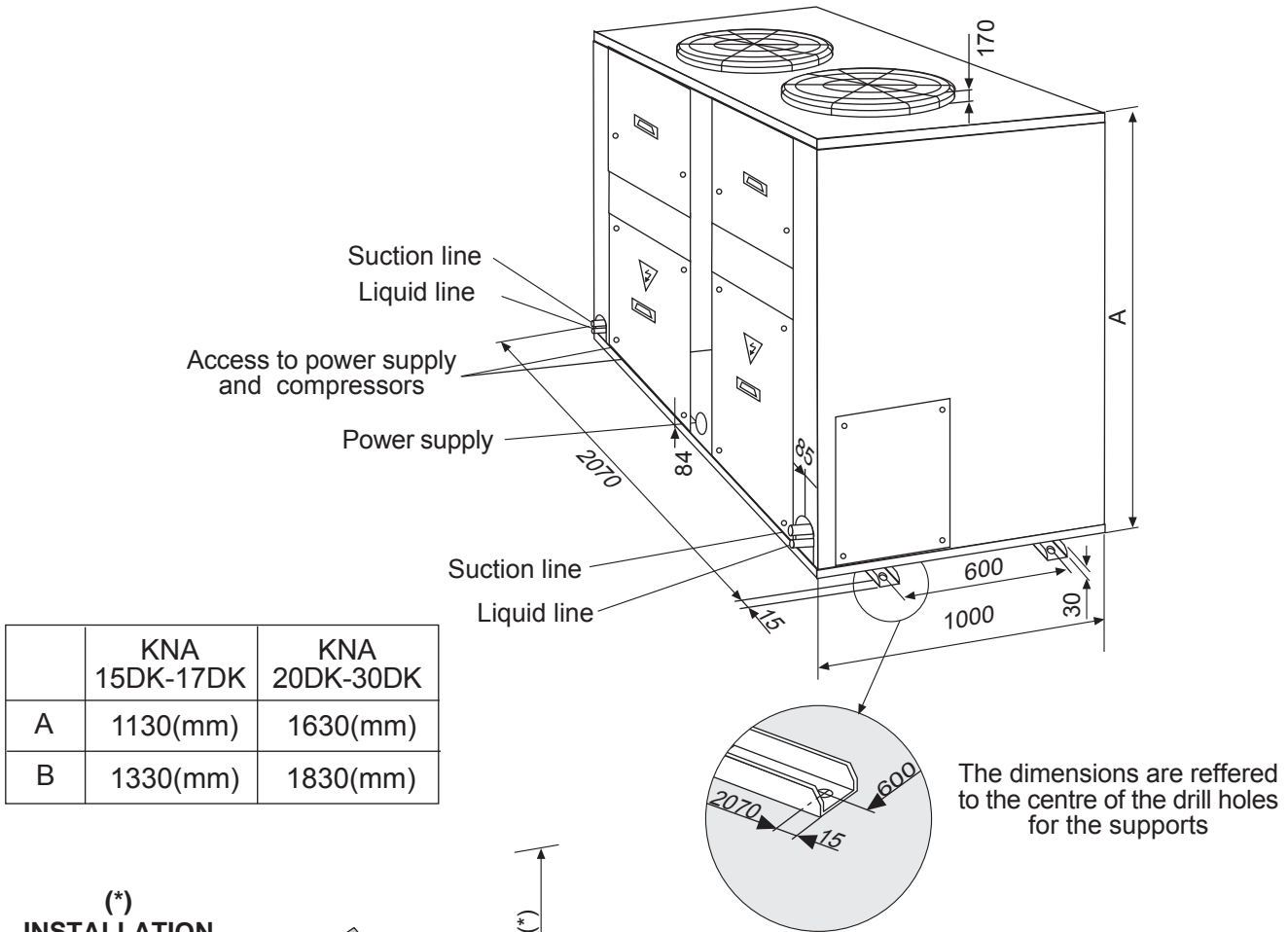

SERVICE SPACE

Space should be left free for servicing, refrigerant connections, drainage connexions, electric installation, as well as easy access to the unit.

LOCATION

The unit should be assembled on bases previously made and stand on absorbant and antivibrating material to avoid the vibrations being trasmitted to the structure of the building.

INSTALLATION

The KNA should be located outdoors as close as possible to the air handling unit, consistent with the desires of the customer and the local codes, with special attention for local sound requirements.

Considering the following factors:

1. All models feature "up-low" condenser air for quit operation. Air is flowing through the condenser and is discharged through the top exhaust grill.
2. Any side of the unit should be located at least 1000 mm from a wall or other obstruction for unrestricted airflow and for a service access .
3. When the unit is installed under a roof allow at least 2500 mm free above top of the unit.
4. Mount the unit on a sturdy base, preferable of concrete. The concrete base should not be in contact with a building foundation, to prevent possible sound or vibration transmission.
5. It is recommended to mount the unit on a vibration absorber.

TROUBLESHOOTING

PROBLEM	CAUSE
KNA does not start	- Main switch off. - Fuse down on PCB. - Control setting improper
High pressure switch removes power from compresor	-Condenser fan motor cuts off due to A. Internal thermal overload fan motor B. Shortcircuit / broken temperature sensor. C. Unit overcharged with refrigerant.
Low pressure switch removes power from compressor	-Insufficient refrigerant charge. -'LP-T' switch is in position A
Condenser fan does not run at modulating speed	-'S' switch is in position A
Compressor stops and run frequently	-'AP-T' switch in position A

MAINTENANCE

WARNING

Electrical shock hazard can cause injury or death. Before attempting to perform any service or maintenance on the unit , TURN OFF the electrical power, and check that the fans have stopped

The unit should be serviced regularly. With this purpose, it is advisable to ask your dealer about maintenance contracts. Depending on the operating conditions the unit following points should be checked at least 4 times a year.

GENERAL

Casing, grills, service panels, fasteners, dirt, corrosion, connections, installation and location.

COMPRESSOR

Noise, temperature, leaking,dirt, corrosion, suction and discharge valve, suction and discharge pressure, fasteners, crankcase heater, current and electrical connections.

CONDENSER

Leaking, dirt, corrosion, obstruction, temperature, sensor with sensorwell.

FANMOTOR

Noise, temperature, dirt, corrosion, impeller, balancing, shaft tolerance, fasteners, current and electrical connections.

REFRIGERANT CIRCUIT

Lines, couplings, check valves, leaking, dirt, corrosion, vibration, insulating, charge,sub-cooling and superheat.

ELECTRICAL CIRCUIT

Operating and setting, pressure switches, condenser fan controller, main switch, contactors, thermal relay, printed circuit control board with switch positions, malfunction-led´s, time settings,check wiring for loose connections.

INSTALLATION-OPERATION
&
MAINTENANCE MANUAL



PROVIDING GLOBAL SYSTEM SOLUTIONS

KNA-K-

GREAT BRITAIN,
IRELAND:

LENNOX INDUSTRIES LTD
tél. : + 44 1604 59 9400
fax : + 44 1604 594200
e-mail : marketing @ lennoxind.com

BELGIUM :

LENNOX BENELUX N.V./S.A.
tél. : + 32 3 633 30 45
fax : + 32 3 633 00 89
e-mail : inf.beo @ lennoxbenelux.com

CZECH REPUBLIC :

JANKA RADOTIN AS
tél. : + 420 2 510 88 111
fax : + 420 2 579 10 393
e-mail : janka @ janka.cz

FRANCE :

LENNOX FRANCE
tél. : + 33 1 60 17 88 88
fax : + 33 1 60 17 86 58
e-mail : accueil @ lennoxfrance.com

GERMANY:

LENNOX DEUTSCHLAND GmbH
tél. : + 49 69 42 0979 0
fax : + 49 69 42 0979 40
e-mail : info @ lennoxdeutschland.com

NETHERLANDS :

LENNOX BENELUX B.V.
tél. : + 31 33 2471 800
fax : + 31 33 2459 220
e-mail : info @ lennoxbenelux.com

POLAND :

LENNOX POLSKA SP z o.o.
tél. : + 48 22 832 26 61
fax : + 48 22 832 26 62
e-mail : lennoxpolska @ inetia.pl

PORTUGAL :

LENNOX CLIMATIZAÇÃO LDA.
tél. : + 351 22 999 84 60
fax : + 351 22 999 84 68
e-mail : marketing @ lennoxportugal.com

RUSSIA :

LENNOX DISTRIBUTION MOSCOW
tél. : + 7 095 246 07 46
fax : + 7 502 933 29 55
e-mail : lennox.dist.moscow @ co.ru

SLOVAKIA :

LENNOX SLOVAKIA
tél. : + 421 7 44 88 92 16
fax : + 421 7 44 88 16 88

SPAIN:

LENNOX REFAC S.A.
tél. : + 34 902 400 405
fax : + 34 91 542 84 04
e-mail : marketing @ lennox-refac.com

UKRAINE :

LENNOX DISTRIBUTION KIEV
tél. : + 380 44 213 14 21
fax : + 380 44 213 14 21
e-mail : jankauk @ uct.kiev.ua

OTHER EUROPEAN COUNTRIES,
AFRICA,
MIDDLE-EAST :

LENNOX DISTRIBUTION
tél. : + 33 4 72 23 20 14
fax : + 33 4 72 23 20 28
e-mail : marketing @ lennoxdist.com



LENNOX®

www.Lennox.com