

**INSTALLATION
OPERATION &
MAINTENANCE MANUAL**

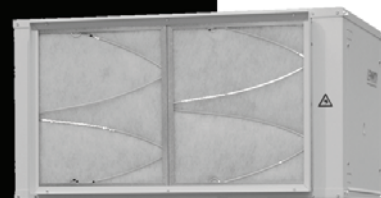
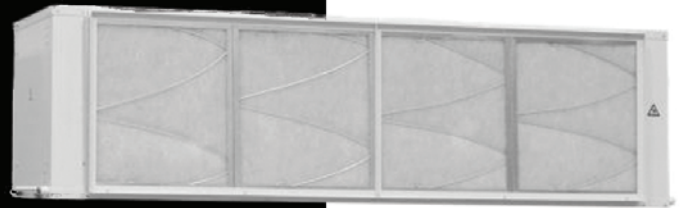

PROVIDING **GLOBAL SYSTEM** SOLUTIONS

**COMPACTAIR
AIRCOOLAIR
LECK / LEHK**

TABLE OF CONTENTS

POINTS TO KEEP IN MIND PAGE 2

DATA PAGE FOR UNIT COMMISSIONING PAGE 3

1.- GENERAL CHARACTERISTICS PAGE

1.1.- PHYSICAL DATA	4
1.2.- ELECTRICAL DATA	5
1.3.- FAN PERFORMANCES	6-9
1.4.- UNIT DIMENSIONS	10-12
1.5.- AVAILABLE OPTIONS	13-26

2.- INSTALLATION PAGE

2.1.- INSTALLATION GUIDELINES	27
2.2.- OPTIONAL TASK PRIOR TO UNIT INSTALLATION: CHANGING THE POSITION OF DISCHARGE AND AIR INTAKE	28-29
2.3.- OPTIONAL TASK PRIOR TO UNIT INSTALLATION: FLOW REGULATION IN THE FANS	30
2.4.- INSTALLATION CLEARANCES	31
2.5.- DRAINS	31
2.6.- REFRIGERANT CONNECTIONS	32
2.7.- ELECTRICAL CONNECTIONS	32

3.- COMMISSIONING AND OPERATION PAGE

3.1.- PRELIMINARY CHECKS	33
--------------------------	----

4.- MAINTENANCE PAGE

4.1.- PREVENTIVE MAINTENANCE	34
------------------------------	----

POINTS TO KEEP IN MIND



Abrasive surfaces



Low temperatures



High temperatures



Risk of injury with moving objects

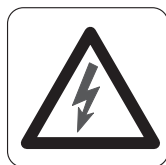

Electrical voltage



Risk of injury with rotating objects

WARNING

Electric shock hazard can cause injury or death. Before attempting to perform any service or maintenance on the unit, turn OFF the electrical power, and check that the fan has stopped.

The air filter cleaning operations do not require technical service; however when an electrical or mechanical operation is required call an Engineer.

FILTER CLEANING

Check the air filter and make sure it is not blocked with dust or dirt.

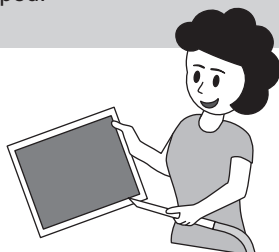
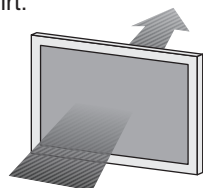

If the filter is dirty, wash it in a bowl with neutral soap and water, drying it in the shade before inserting it in the unit.

Standard Guidelines to Lennox equipment

All technical data contained in these operating instructions including the diagrams and technical description remains the property of Lennox and may not be used (except for the purpose of familiarizing the user with the equipment), reproduced, photocopied, transferred or transmitted to third parties without prior written authorization from Lennox .

The data published in the operating instructions is based on the latest information available. We reserve the right to make modifications without notice.

We reserve the right to modify our products without notice without obligation to modify previously supplied goods.

These operating instructions contain useful and important information for the smooth operation and maintenance of your equipment.

The instructions also include guidelines on how to avoid accidents and serious damage before commissioning the equipment and during its operation and how to ensure smooth and fault-free operation. Read the operating instructions carefully before starting the equipment, familiarize yourself with the equipment and handling of the installation and carefully follow the instructions. It is very important to be properly trained in handling the equipment. These operating instructions must be kept in a safe place near the equipment.

Like most equipment, the unit requires regular maintenance. This section concerns the maintenance personnel and management.

If you have any queries or would like to receive further information on any aspect relating to your equipment, do not hesitate to contact us.

DATA PAGE FOR UNIT COMMISSIONING

UNIT: _____ SERIAL Nr.: _____

CONTROL PANEL IDENTIFICATION CODE _____

INSTALLATION ADDRESS: _____

INSTALLER: _____ INSTALLER TEL.: _____

INSTALLER ADDRESS: _____

DATE OF COMMISSIONING: _____

CHECKS:

SUPPLY VOLTAGE: _____ RATED VOLTAGE OF THE UNIT: _____

	YES	NO
DRAINAGE WITH TRAP	<input type="checkbox"/>	<input type="checkbox"/>
CLEAN INTERIOR AIR FILTER	<input type="checkbox"/>	<input type="checkbox"/>
GENERAL POWER SUPPLY CONNECTION	<input type="checkbox"/>	<input type="checkbox"/>

DATA INPUT:

COLD CYCLE

Air Intake Temperature, Indoor Coil: _____ °C

High Pressure: _____

Low Pressure: _____

HEATING CYCLE

Air Intake Temperature, Indoor Coil: _____ °C

High Pressure: _____

Low Pressure: _____

ELECTRIC POWER CONSUMPTION (Amps)

Fan indoor section _____/_____/_____

Fan indoor section _____/_____/_____

Options Installed: _____

Comments: _____

1.- GENERAL CHARACTERISTICS

1.1.- PHYSICAL DATA

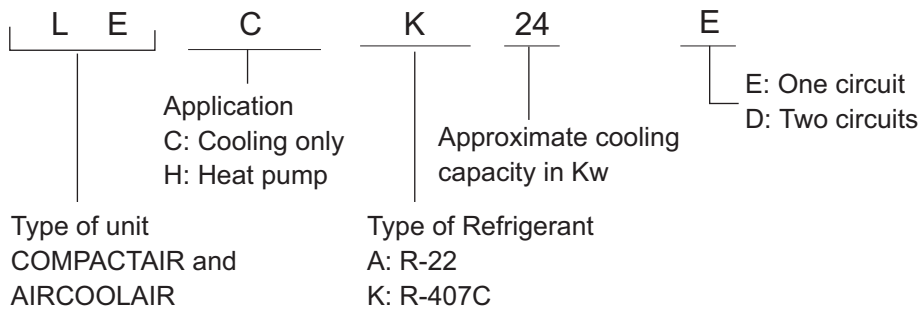

LEHA: Heat pump unit R-22
 LECK: Cooling only unit R-407C
 LEHK: Heat pump unit R-407C

UNIT MODELS	22E	24E	28E	32E	38E
NET WEIGHT	105	105	110	110	145

UNIT MODELS	43E	50E	44D	48D	56D
NET WEIGHT	280	305	220	220	240

UNIT MODELS	64D	76D	86D	100D
NET WEIGHT	240	265	270	295

1.- GENERAL CHARACTERISTICS

1.2.- ELECTRICAL DATA

UNIT MODELS		LECK 22E LEHK 22E LEHA 22E	LECK 24E LEHK 24E LEHA 24E	LECK 28E LEHK 28E LEHA 28E	LECK 32E LEHK 32E LEHA 32E	LECK 38E LEHK 38E LEHA 38E
Voltage	V/f (50 Hz)	230V-400V/ 3Ph				
Maximum absorbed power	Kw	1,3	1,4	1,5	1,8	2,0
Maximum current	A	4,3/2,5	4,3/2,5	6,2/3,6	6,2/3,6	6,2/3,6
Start up current	A	20,4/11,8	20,4/11,8	32,5/18,8	32,5/18,8	32,5/18,8

UNIT MODELS		LECK 43E LEHK 43E LEHA 43E	LECK 50E LEHK 50E LEHA 50E	LECK 44D LEHK 44D LEHA 44D	LECK 48D LEHK 48D LEHA 48D	LECK 56D LEHK 56D LEHA 56D
Voltage	V/f (50 Hz)	230V-400V/ 3Ph				
Maximum absorbed power	Kw	2,5	2,8	2,6	2,8	3,0
Maximum current	A	10,3/6	10,3/6	8,8/5,1	8,8/5,1	12,5/7,2
Start up current	A	65,5/38	65,5/38	46,7/27	46,7/27	64,7/37,4

UNIT MODELS		LECK 64D LEHK 64D LEHA 64D	LECK 76D LEHK 76D LEHA 76D	LECK 86D LEHK 86D LEHA 86D	LECK 100D LEHK 100D LEHA 100D
Voltage	V/f (50 Hz)	230V-400V/ 3Ph			
Maximum absorbed power	Kw	3,6	4,0	5	5,5
Maximum current	A	12,5/7,2	12,5/7,2	20,6/11,9	20,6/11,9
Start up current	A	64,7/37,4	64,7/37,4	131/76	131/76

1.- GENERAL CHARACTERISTICS

1.3.- STANDARD FAN PERFORMANCES.

		22E					24E						
AIR FLOW		R.P.M.	M³/H	3500	3900	4300	4700	R.P.M.	M³/H	3900	4300	4700	5100
PULLEY POSITION	PULLEY CLOSED	890	205*	195*	165*	130*	890	195*	165*	130*	85*		
	1 TURN	840	165*	150*	125*	90*	840	150*	125*	90*	50*		
	2 TURNS	790	130*	115*	90*	55*	790	115*	90*	55*	15*		
	3 TURNS	740	105*	80*	60*	20*	740	80*	60*	20*	___		

		28E					32E						
AIR FLOW		R.P.M.	M³/H	4500	4950	5400	5850	R.P.M.	M³/H	4750	5250	5750	6000
PULLEY POSITION	PULLEY CLOSED	1010	250*	200*	95*	30*	1010	220*	175*	115*	70*		
	1 TURN	955	190*	145*	40*	___	955	165*	115*	50*	0*		
	2 TURNS	900	145*	100*	0*	___	900	125*	65*	0*	___		
	3 TURNS	845	105*	55*	___	___	845	80*	25*	___	___		

		38E					43E						
AIR FLOW		R.P.M.	M³/H	5800	6400	7000	7300	R.P.M.	M³/H	6500	7250	8000	8750
PULLEY POSITION	PULLEY CLOSED	1010	240*	200*	●	●	1075	290*	245*	185*	135*		
	1 TURN	955	190*	150*	100*	●	1010	235*	185*	125*	95*		
	2 TURNS	900	150*	110*	65*	40*	940	180*	125*	60*	0*		
	3 TURNS	845	105*	60*	15*	0*	870	140*	85*	20*	___		

		50E					44D						
AIR FLOW		R.P.M.	M³/H	7250	8000	8750	9000	R.P.M.	M³/H	7000	7800	8600	9400
PULLEY POSITION	PULLEY CLOSED	1140	300*	245*	185*	●	890	205*	195*	165*	130*		
	1 TURN	1070	230*	170*	100*	75*	840	165*	150*	125*	90*		
	2 TURNS	995	150*	105*	35*	10*	790	130*	115*	90*	55*		
	3 TURNS	920	70*	35*	___	___	740	105*	80*	60*	20*		

		48D					56D						
AIR FLOW		R.P.M.	M³/H	7800	8600	9400	10200	R.P.M.	M³/H	9000	9900	10800	11700
PULLEY POSITION	PULLEY CLOSED	890	195*	165*	130*	85*	1010	250*	200*	95*	30*		
	1 TURN	840	150*	125*	90*	50*	955	190*	145*	40*	___		
	2 TURNS	790	115*	90*	55*	15*	900	145*	100*	0*	___		
	3 TURNS	740	80*	60*	20*	___	845	105*	55*	___	___		

(*) STATIC PRESSURE AVAILABLE Pa.

(●) WRONG STATUS ON ACCOUNT OF MOTOR POWER LIMIT

NOTE: The unit leaves factory with pulley two turns opened.

1.- GENERAL CHARACTERISTICS

1.3.- STANDARD FAN PERFORMANCES.

		64D					76D						
AIR FLOW		R.P.M.	M³/H	9500	10500	11500	12000	R.P.M.	M³/H	11600	12800	14000	14600
PULLEY POSITION	PULLEY CLOSED	1010	220*	175*	115*	70*	1140	240*	200*	●	●		
	1 TURN	955	165*	115*	50*	0*	1070	190*	150*	100*	●		
	2 TURNS	900	125*	65*	0*	—	995	150*	110*	65*	40*		
	3 TURNS	845	80*	25*	—	—	920	105*	60*	15*	0*		

		86D					100D						
AIR FLOW		R.P.M.	M³/H	13000	14500	16000	17500	R.P.M.	M³/H	14500	16000	17500	18000
PULLEY POSITION	PULLEY CLOSED	1055	270*	225*	165*	115*	1120	280*	225*	165*	●		
	1 TURN	1010	235*	185*	125*	95*	1080	235*	175*	105*	80*		
	2 TURNS	965	195*	145*	85*	35*	1030	195*	135*	65*	30*		
	3 TURNS	920	160*	110*	45*	—	980	145*	90*	20*	0*		

(*) STATIC PRESSURE AVAILABLE Pa.

(●) WRONG STATUS ON ACCOUNT OF MOTOR POWER LIMIT

NOTE: The unit leaves factory with pulley two turns opened.

1.- GENERAL CHARACTERISTICS

1.3.- INDOOR FAN PERFORMANCES WITH KIT HIGH STATIC PRESSURE TO 400Pa (OPTION)

		22E					24E						
AIR FLOW		R.P.M.	M ³ /H	3500	3900	4300	4700	R.P.M.	M ³ /H	3900	4300	4700	5100
PULLEY POSITION	PULLEY CLOSED	1140	420*	405*	385*	360*		1140	405*	385*	360*	●	
	1 TURN	1070	360*	340*	315*	290*		1070	340*	315*	290*	●	
	2 TURNS	995	290*	275*	250*	205*		995	275*	250*	205*	195*	
	3 TURNS	920	240*	215*	190*	160*		920	215*	190*	160*	130*	

		28E					32E						
AIR FLOW		R.P.M.	M ³ /H	4500	4950	5400	5850	R.P.M.	M ³ /H	4750	5250	5750	6000
PULLEY POSITION	PULLEY CLOSED	1200	410*	390*	320*	290*		1200	400*	365*	300*	270*	
	1 TURN	1125	340*	305*	240*	210*		1125	330*	290*	220*	190*	
	2 TURNS	1050	275*	240*	165*	130*		1050	265*	225*	145*	110*	
	3 TURNS	970	215*	175*	100*	60*		970	205*	160*	80*	40*	

		38E					43E						
AIR FLOW		R.P.M.	M ³ /H	5800	6400	7000	7300	R.P.M.	M ³ /H	6500	7250	8000	8750
PULLEY POSITION	PULLEY CLOSED	1200	450*	425*	385*	●		1200	410*	390*	325*	●	
	1 TURN	1125	380*	360*	310*	●		1125	340*	315*	240*	205*	
	2 TURNS	1050	310*	280*	220*	205*		1050	270*	245*	165*	130*	
	3 TURNS	970	245*	215*	155*	140*		970	215*	185*	105*	60*	

		50E					44D						
AIR FLOW		R.P.M.	M ³ /H	7250	8000	8750	9000	R.P.M.	M ³ /H	7000	7800	8600	9400
PULLEY POSITION	PULLEY CLOSED	1200	380*	315*	●	●		1140	420*	405*	385*	360*	
	1 TURN	1125	305*	230*	195*	●		1070	360*	340*	315*	290*	
	2 TURNS	1050	235*	155*	120*	65*		995	290*	275*	250*	205*	
	3 TURNS	970	175*	95*	50*	—		920	240*	215*	190*	160*	

		48D					56D						
AIR FLOW		R.P.M.	M ³ /H	7800	8600	9400	10200	R.P.M.	M ³ /H	9000	9900	10800	11700
PULLEY POSITION	PULLEY CLOSED	1140	405*	385*	360*	●		1200	410*	390*	320*	290*	
	1 TURN	1070	340*	315*	290*	●		1125	340*	305*	240*	210*	
	2 TURNS	995	275*	250*	205*	195*		1050	275*	240*	165*	130*	
	3 TURNS	920	215*	190*	160*	130*		970	215*	175*	100*	60*	

(*) STATIC PRESSURE AVAILABLE Pa.

(●) WRONG STATUS ON ACCOUNT OF MOTOR POWER LIMIT

NOTE: The unit leaves factory with pulley two turns opened.

1.- GENERAL CHARACTERISTICS

1.3.- INDOOR FAN PERFORMANCES WITH KIT HIGH STATIC PRESSURE TO 400Pa (OPTION)

		64D					76D						
AIR FLOW		R.P.M.	M ³ /H	9500	10500	11500	12000	R.P.M.	M ³ /H	11600	12800	14000	14600
PULLEY POSITION	PULLEY CLOSED	1200	400*	365*	300*	●	1200	450*	425*	●	●		
	1 TURN	1125	330*	290*	220*	190*	1125	380*	360*	310*	●		
	2 TURNS	1050	265*	225*	145*	110*	1050	310*	280*	220*	●		
	3 TURNS	970	205*	160*	80*	40*	970	245*	215*	155*	140*		

		86D					100D						
AIR FLOW		R.P.M.	M ³ /H	13000	14500	16000	17500	R.P.M.	M ³ /H	14500	16000	17500	18000
PULLEY POSITION	PULLEY CLOSED	1200	410*	390*	●	●	1200	380*	315*	●	●		
	1 TURN	1150	365*	345*	265*	●	1150	335*	255*	●	●		
	2 TURNS	1100	315*	295*	215*	●	1100	285*	205*	●	●		
	3 TURNS	1050	270*	245*	165*	130*	1050	235*	155*	120*	●		

(*) STATIC PRESSURE AVAILABLE Pa.

(●) WRONG STATUS ON ACCOUNT OF MOTOR POWER LIMIT

NOTE: The unit leaves factory with pulley two turns opened.

1.- GENERAL CHARACTERISTICS

1.4.- UNIT DIMENSIONS MODELS 22E-24E-28E-32E

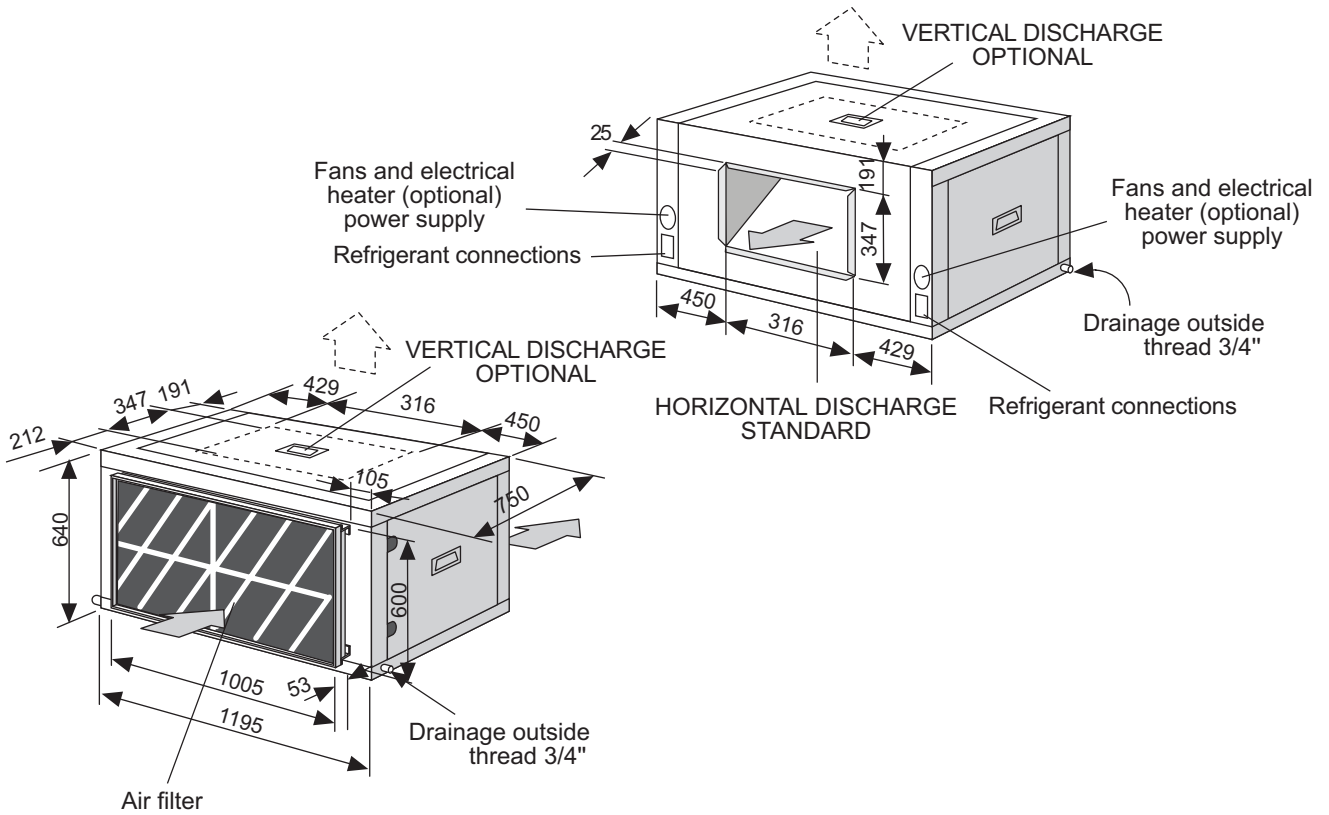

1.4.- UNIT DIMENSIONS MODEL 38E

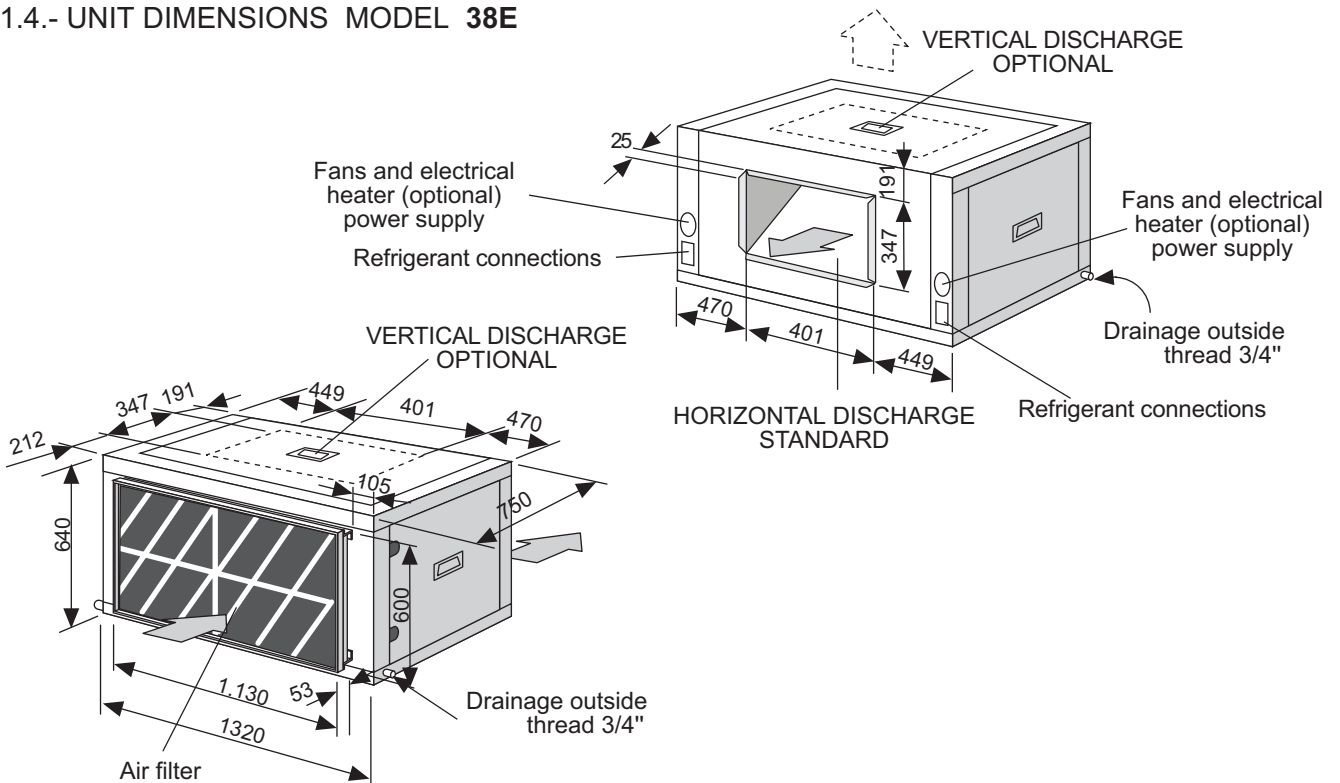

1.- GENERAL CHARACTERISTICS

1.4.- UNIT DIMENSIONS MODELS 43E-50E

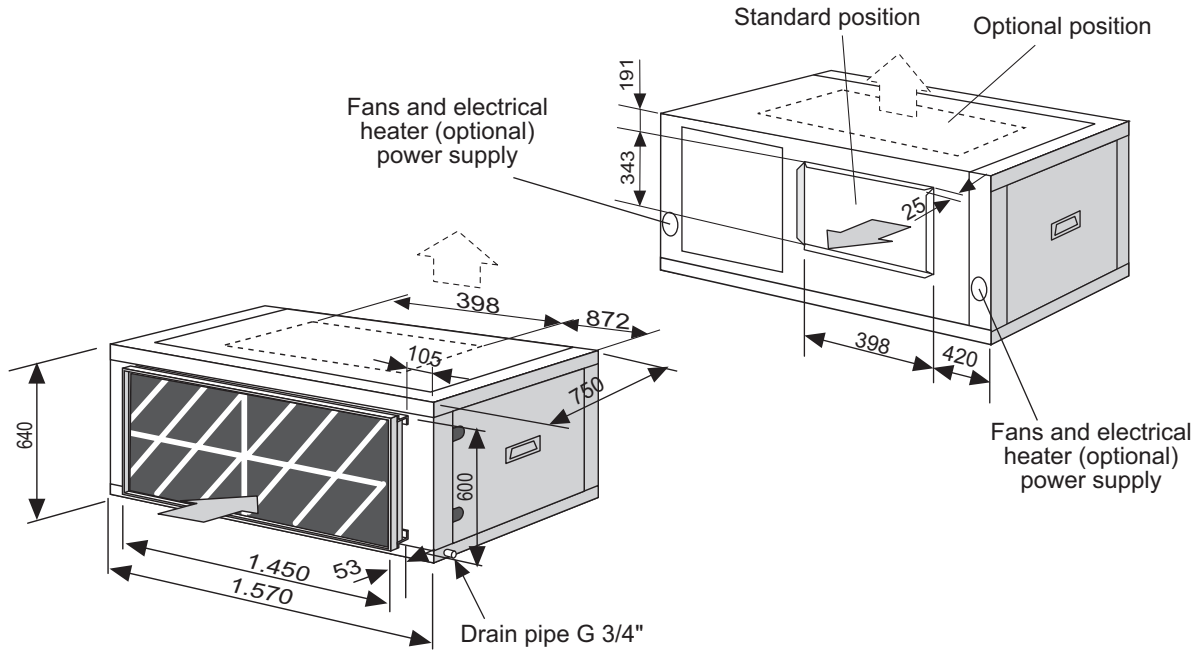

1.4.- UNIT DIMENSIONS MODELS 44D-56D-64D

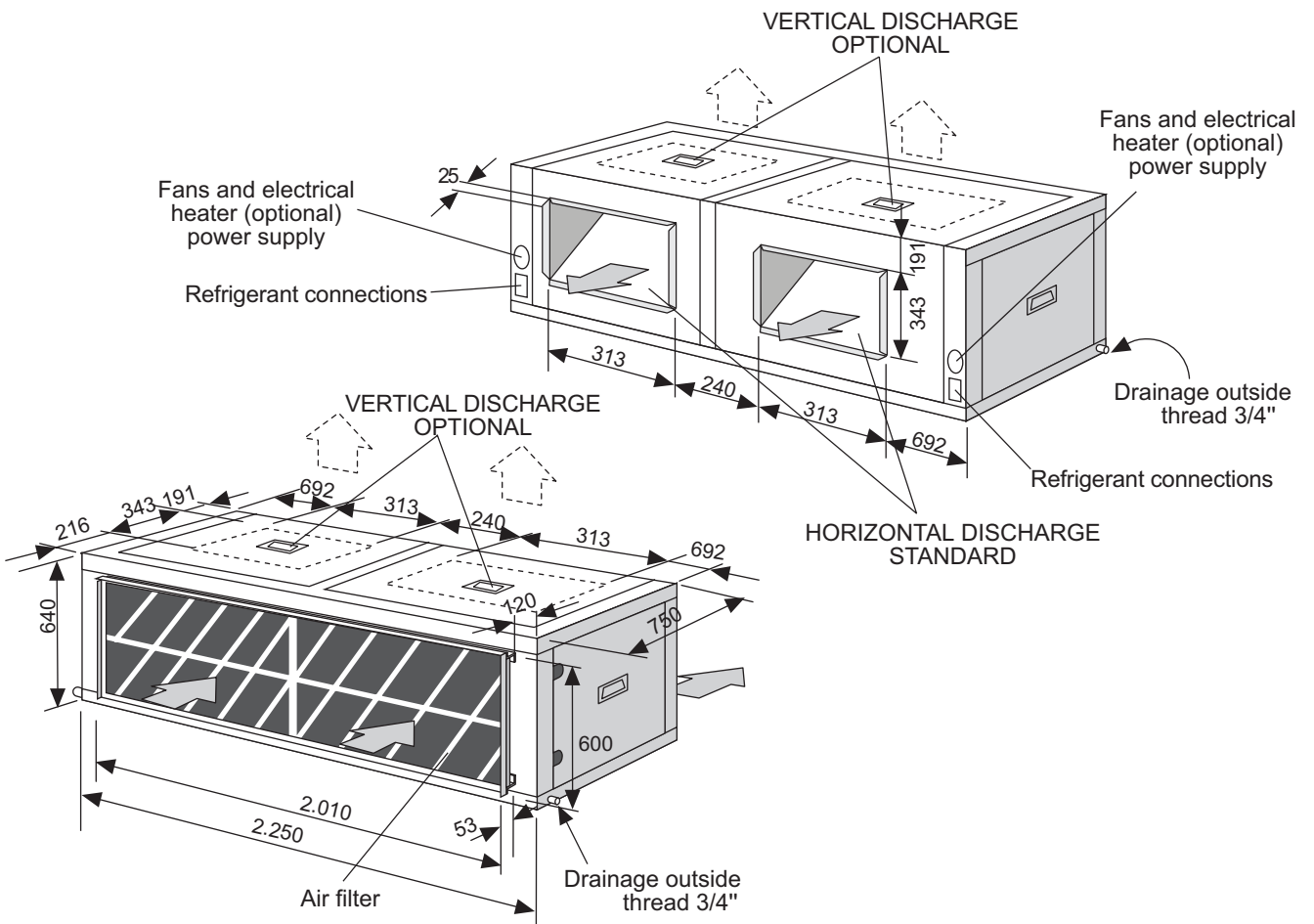

1.- GENERAL CHARACTERISTICS

1.4.- UNIT DIMENSIONS MODEL 76D

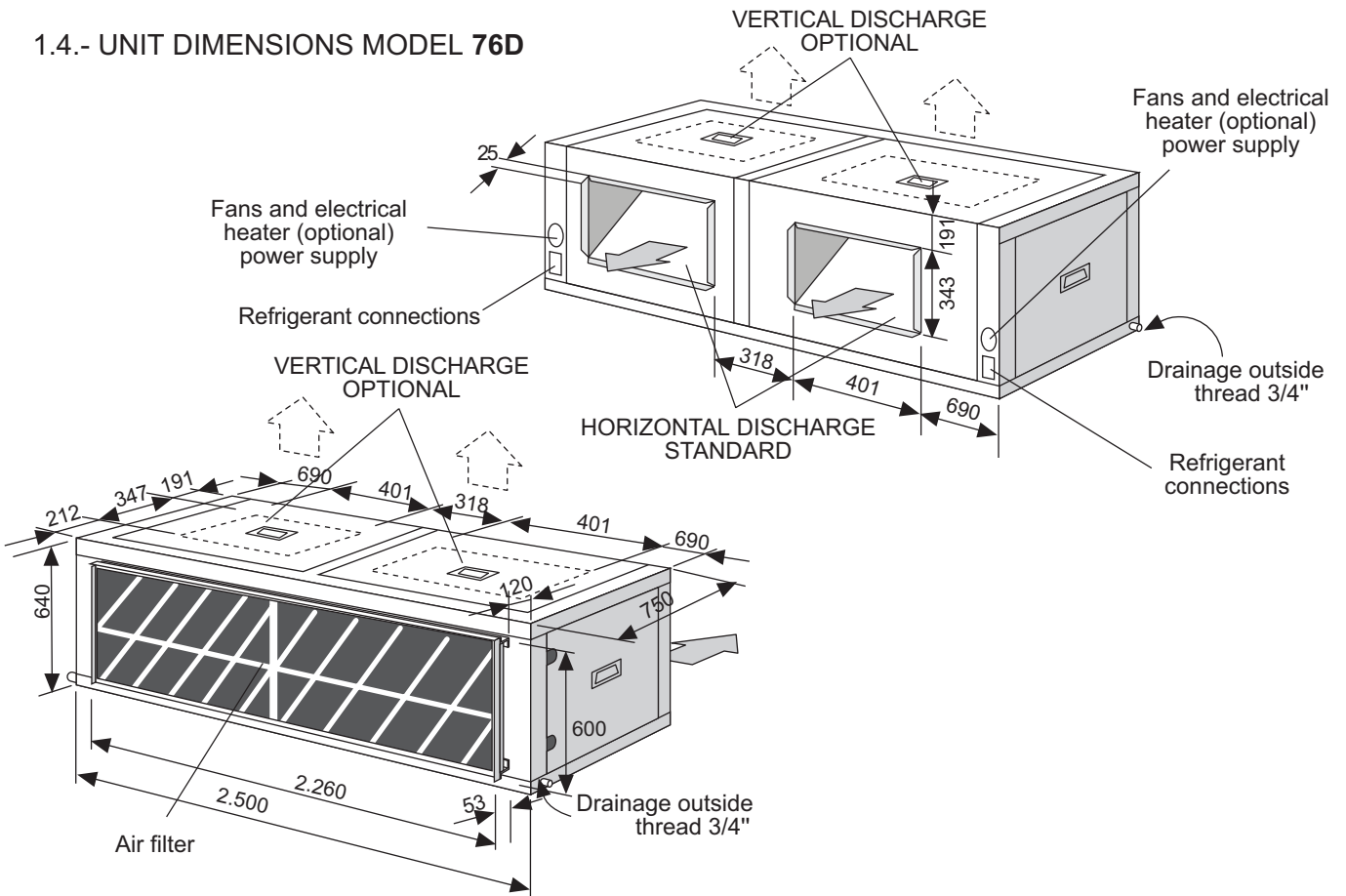

1.4.- UNIT DIMENSIONS MODELS 86D-100D

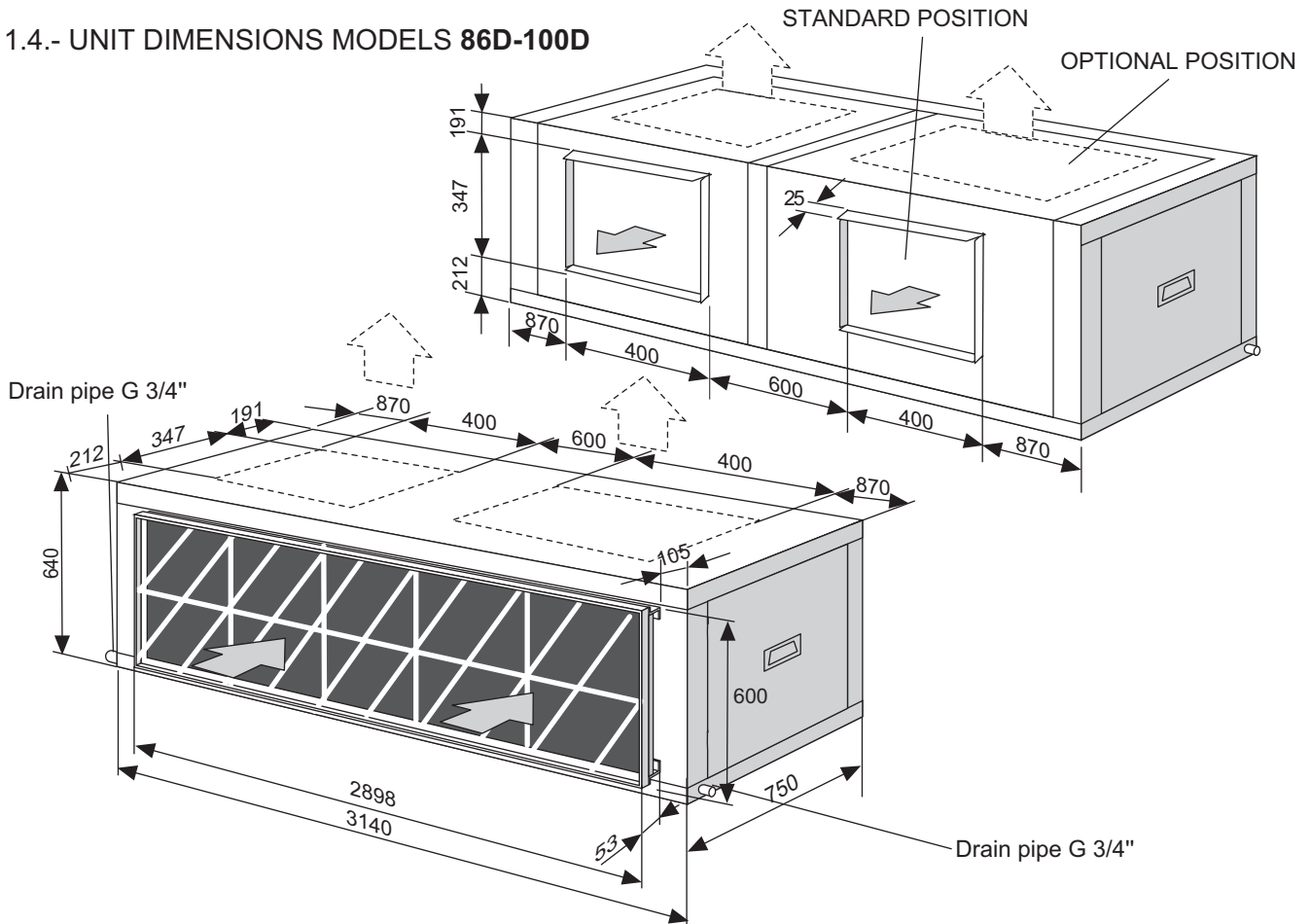

1.- GENERAL CHARACTERISTICS

1.5.- AVAILABLE OPTIONS

ELECTRICAL HEATER

Made of align shielded elements, supplied mounted on the unit as drawing shows.

All the range have three security elements: 2 security thermostat, one automatic other manual reset and an air flow security pressostat, which make the electrical heater stops when air flow is not enough.

The electrical heater must be supply on from the unit's electrical box.

An small case on the electrical heater protects contactors and electrical connections.

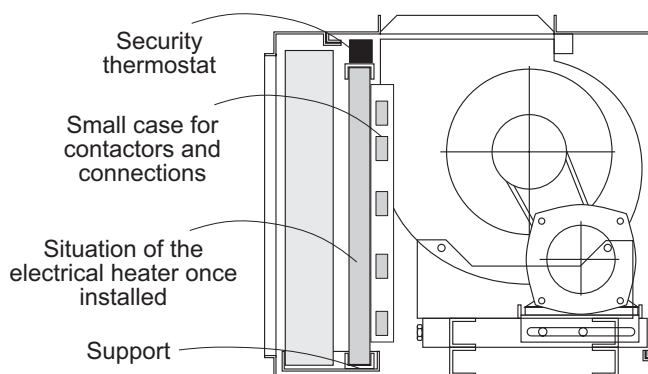

MODELS LEC	22E-24E-28E-32E-38E			43E-50E		44D-48D-56D-64D-76D				86D-100D		
POWER Kw	7,5	11	15	11	15	11	15	20	30	22,5	30	
MAXIMUM CURRENT (A)	230 / III	18,8	27,6	37,7	27,6	37,7	27,6	37,7	50,2	75,3	56,5	75,3
	400/ III	10,8	15,9	21,7	15,9	21,7	15,9	21,7	28,9	43,3	32,5	43,3
WEIGHTS Kg (*)	10			10		20				30		
STAGES	1			1		2				2		

(*) Add to the unit's weight.

MODELS LEH	22E-24E-28E-32E-38E			43E-50E		44D-48D-56D-64D-76D				86D-100D	
POWER Kw	7,5	11	15	7,5	11	11	15	20	15	22,5	
MAXIMUM CURRENT (A)	230 / III	18,8	27,6	37,7	18,8	27,6	27,6	37,7	50,2	37,7	56,5
	400/ III	10,8	15,9	21,7	10,8	15,9	15,9	21,7	28,9	21,7	32,5
WEIGHTS Kg (*)	10			10		20				30	
STAGES	1			1		1				1	

(*) Add to the unit's weight.

DIRTY FILTER INDICATION

To install on the indoor unit.

Based on an air flow security pressostat which detect, the static pressure available through the air filter.

In case the filters are dirties, the detector is activate, showing an alarm, if the fan is ON.

1.- GENERAL CHARACTERISTICS

1.5.- AVAILABLE OPTIONS

HOT WATER COIL

Base on a refrigerating coil. made of copper tubing with aluminum swirl fins with inlet and outlet water connections.

It is supply mounted inside the unit as picture shows.

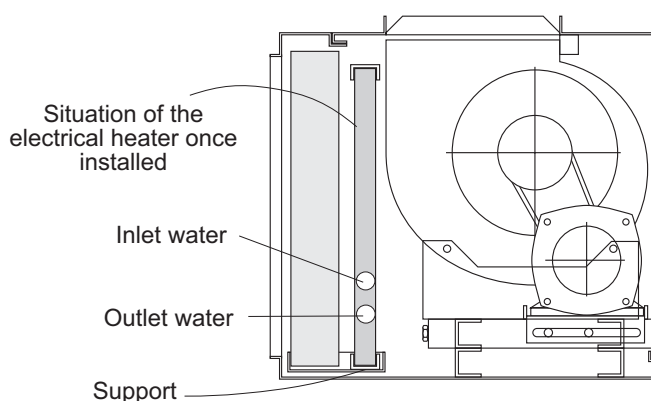

MODELS LEC / LEH	DIFFERENCE IN TEMPERATURES BETWEEN HOT WATER INTAKE AND THE AIR WHICH ENTERS THE BATTERY			WATER FLOW L/H	WATER COIL PRESSURE DROP Kpa	AIR PRESSURE DROP Pa (*)	Nr ROWS	WEIGHT Kg	OUTLET WATER DIAMETER Inches
	50°C	60°C	70°C						
22E-24E	CAPACITY EN W			2.200	8	32-40	2	10	2
	29.000	36.000	44.000						
28E-32E	CAPACITY EN W			2.500	10	32-40	2	10	2
	33.000	40.000	47.000						
38E	CAPACITY EN W			3.000	15	40	2	12	2
	40.000	48.000	56.000						
44D-48D	CAPACITY EN W			4.400	8	32-40	2	20	2
	58.000	62.000	88.000						
56D-64D	CAPACITY EN W			5.000	10	32-40	2	20	2
	66.000	80.000	94.000						
76D	CAPACITY EN W			6.000	15	39	2	24	2
	80.000	96.000	112.000						

(*) Nominal air flow volume

KIT MORE STATIC PRESSURE OF AIR DISCHARGE

It is an specific fan to obtain mores static available pressure up to 400Pa.

See air flow data section for optional fan performances.

Electrical data for these optional fans:

LEC / H MODELS	22E	24E	28E	32E	38E	43E	50E	44D	48D	56D	64D	76D	86D	100D
POWER (*) Kw	0,2	0,4	0,8	1,0	1	0,8	0,8	0,4	0,8	1,5	1,5	1,7	1,5	1,5
MAXIMUM CURRENT (*) (A)	230 / III	0,5	1,0	2,0	2,5	2,5	2,0	2,0	1,0	2,0	3,8	3,8	4,3	3,8
	400/ III	0,3	0,6	1,2	1,4	1,4	1,2	1,2	0,6	1,2	2,2	2,2	2,5	2,2
WEIGHTS Kg (*)	0	0	2	2	0	0	0	5	5	9	9	9	0	0

(*) Add to the unit data.

1.- GENERAL CHARACTERISTICS

1.5.- AVAILABLE OPTIONS

FREECOOLING

1.- DEFINITION

FREE-COOLING is a saving system in the Cold cycle, this makes the unit take air from the outside to take advantage of its energy, this system acting as a first cold stage.

It is a saving energy system that's why many countries regulations recommended and others put under an obligation to install a freecooling system with the unit.

2.- TYPES OF FREECOOLING.

In order to outside air parameters which has to be measured, the types are:

- **Thermostatic freecooling :**

Measures and comparing the outside air temperature, with the temperature of the room that has to be aconditioned.

- **Enthalpic freecooling :**

Measures and comparing the outside air enthalpy, with the return air enthalpy from the room that has to be aconditioned.

The enthalpy measures temperature and humidity of air.

3.- COMPONENTS OF FREECOOLING.

The main components are:

-Electronic control and accessories: Their function is to detect the outside and indoor air conditions through the probes, to solve when freecooling should operate

-The servomotor and system transmission: They manage open and close the dampers

- Adjustable dampers

-Mixing section: Where outside and return air are mixed.

Also an extra fan is available, which applied an additional static pressure on the suction and return air duct.

For more details about components and drawings see pages 19,20,21,22.

4.- OPERATION

The control compares the values of temperature/enthalpy between outside air and room air through the probes, if it is a negative difference and the security elements allows (discharge temperature probes) then the control acts over the servomotor, which produces the opening of the outside damper and close the return one, entering cool outside air to the room.

The damper regulation is proportional.

If indoor air demand is not great, could be enough only the freecooling to aconditioned the room, if the air demand is greater it is possible need the freecooling working and the unit working on different cooling mode stages.

5.- THERMOSTAT TERMINAL .

Depends on the type of freecooling selected, the thermostat and the electrical box supplied with the unit will be different.

With thermostatic freecooling the thermostat supplied has the same characteristics than the one supplied with the standard unit, except because the one for the freecooling is a programmable one.

With enthalpic freecooling the terminal is different than the one supplied with the unit VFC version, its principal characteristics are: OFF, COOL, HEAT, AUTOMATIC.

THERMOSTAT FOR THERMOSTATIC FREECOOLING

Thermostatic freecooling is supplied with sensor incorporated inside the thermostat.
Remote duct and ambient sensor are available as an option.

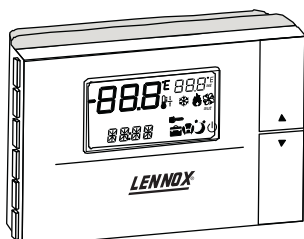

THERMOSTAT FOR ENTHALPIC FREECOOLING

Enthalpic freecooling is supplied with duct sensor.
Remote ambient sensor and sensor incorporated inside the thermostat are available as an option.

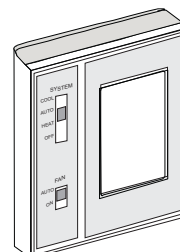

1.- GENERAL CHARACTERISTICS

1.5.- AVAILABLE OPTIONS

FREECOOLING

6.- SUPPLIED AND INSTALLATION

The freecooling system could be supplied mounted or loose, depends on the unit required.

Configuration of freecooling supply :

- Split units:

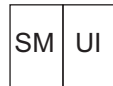

22E ÷ 100D

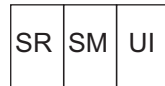

22E ÷ 64D

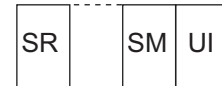

76 /86 /100D

UNITS

SM: Mixing section

SR: Extra fan section

UI: Indoor unit.

UE: Outdoor unit.

--- Mechanical installation to be carried out by the installer

① Freecooling supports, to be carried out by the installer

The electrical box for the freecooling is supplied apart and has to be fixed by the installer.

7.- FREECOOLING WITH EXTRA FAN

If an extra static pressure is required on the return air duct, the freecooling should add an extra fan section.

This extra fan section, include a discharge damper.

The operation dampers for this freecooling with extra fan is as follow:

As much as the air intake damper opens, that much the by-pass damper closes and the discharge air damper opens, for the air return suction (see drawing)

This means that at the same time reach a free cooled of the room, the discharge or return air and the air of the room gets removable.

The consumption of the extra fan by unit is:

MODELS		22E	24E	28E	32E	38E	43E	50E	44D	48D	56D	64D	76D	86D	100D
POWER Kw		1,3	1,4	1,5	1,8	2	2,5	2,8	2,6	2,8	3	3,6	4	5	5,5
MAXIMUM CURRENT (A)	230 / III	4,3	4,3	6,2	6,2	6,2	10,3	10,3	8,8	8,8	12,5	12,5	12,5	20,6	20,6
	400/ III	2,5	2,5	3,6	3,6	3,6	6	6	5,1	5,1	7,2	7,2	7,2	11,9	11,9

1.- GENERAL CHARACTERISTICS

1.5.- AVAILABLE OPTIONS FREECOOLING

Extra fan performances for each models are:

		22E					24E						
AIR FLOW		R.P.M.	M ³ /H	3500	3900	4300	4700	R.P.M.	M ³ /H	3900	4300	4700	5100
PULLEY POSITION	PULLEY CLOSED	1010	175*	145*	115*	70*		1010	145*	115*	70*	35*	
	1 TURN	955	135*	105*	70*	35*		955	105*	70*	35*	0*	
	2 TURNS	900	110*	85*	33*	0*		900	85*	33*	0*	___	
	3 TURNS	845	75*	50*	5*	___		845	50*	5*	___	___	

		28E					32E						
AIR FLOW		R.P.M.	M ³ /H	4500	4950	5400	5850	R.P.M.	M ³ /H	4750	5250	5750	6000
PULLEY POSITION	PULLEY CLOSED	1140	175*	130*	85*	30*		1140	160*	80*	35*	0*	
	1 TURN	1070	130*	80*	30*	0*		1070	110*	40*	0*	___	
	2 TURNS	995	80*	30*	0*	___		995	60*	0*	___	___	
	3 TURNS	920	35*	0*	___	___		920	10*	___	___	___	

		38E					44D						
AIR FLOW		R.P.M.	M ³ /H	5800	6400	7000	7300	R.P.M.	M ³ /H	7000	7800	8600	9400
PULLEY POSITION	PULLEY CLOSED	890	210*	183*	145*	125*		1010	330*	320*	300*	280*	
	1 TURN	840	170*	140*	104*	85*		955	290*	275*	250*	230*	
	2 TURNS	790	130*	95*	45*	35*		900	250*	235*	210*	180*	
	3 TURNS	740	85*	60*	20*	0*		845	200*	195*	150*	130*	

		48D					56D						
AIR FLOW		R.P.M.	M ³ /H	7800	8600	9400	10200	R.P.M.	M ³ /H	9000	9900	10800	11700
PULLEY POSITION	PULLEY CLOSED	1010	320*	300*	280*	●		1010	280*	240*	220*	180*	
	1 TURN	955	275*	250*	230*	185*		955	250*	205*	160*	110*	
	2 TURNS	900	235*	210*	180*	130*		900	195*	160*	110*	70*	
	3 TURNS	845	195*	150*	130*	85*		845	150*	115*	70*	30*	

		64D					76D						
AIR FLOW		R.P.M.	M ³ /H	9500	10500	11500	12000	R.P.M.	M ³ /H	11600	12800	14000	14600
PULLEY POSITION	PULLEY CLOSED	1010	275*	245*	185*	155*		890	200*	175*	140*	120*	
	1 TURN	955	220*	175*	130*	105*		840	160*	135*	100*	90*	
	2 TURNS	900	175*	130*	75*	55*		790	120*	85*	50*	35*	
	3 TURNS	845	125*	85*	30*	20*		740	75*	50*	10*	0*	

		86D					100D						
AIR FLOW		R.P.M.	M ³ /H	13000	14500	16000	17500	R.P.M.	M ³ /H	14500	16000	17500	18000
PULLEY POSITION	PULLEY CLOSED	1055	330*	290*	240*	170*		1055	290*	240*	170*	140*	
	1 TURN	1010	280*	245*	190*	120*		1010	245*	190*	120*	80*	
	2 TURNS	965	245*	210*	155*	90*		965	210*	155*	90*	50*	
	3 TURNS	920	210*	170*	100*	45*		920	170*	100*	45*	0*	

(*) STATIC PRESSURE AVAILABLE PA.

(●) WRONG STATUS ON ACCOUNT OF MOTOR POWER LIMIT.

NOTE: The unit leaves factory with pulley two turns opened.

1.- GENERAL CHARACTERISTICS

1.5.- AVAILABLE OPTIONS

FREECOOLING

8.- SELECTION OF THE UNIT AND FREECOOLING SYSTEM

There are different types of freecooling system , different possibilities of dampers installations, and it could be supplied mounted or loose.

In order to provide the customer the needed one, fill in the following table and sent it to the order department:

INSTALLER COMPANY NAME _____ CONTACT PERSON NAME: _____

TEL.: _____ Fax _____ e-mail _____

ATTENTION TO : Lennox Refac S.A. CONTACT PERSON NAME: _____

TEL.: _____ Fax _____ e-mail _____

ORDER NUMBER: _____

A- Select the unit needed, packaged, split or multi-split:

(If the unit needed is packaged, the freecooling will be supplied loose. If the unit selected is split or multi-split the freecooling will be supplied mounted on the indoor unit, except for the freecooling with extra fan on models 76D, which is supplied loose also)

Packaged Split Multi-split

B- Select the air flow drive of the indoor unit required: Horizontal or vertical

Packaged units: As standard vertical air flow drive

Split and multi-split systems: As standard horizontal air flow drive

Vertical Horizontal

C.-Select the type of freecooling thermostatic or enthalpic and the sensor for freecooling management.

Thermostatic freecooling supplied with sensor incorporated inside the thermostat,

Enthalpic freecooling supplied with duct sensor

(If the humidity conditions where the unit is going to be install have relevance, is convenient to install an enthalpic freecooling)

Thermostatic <input type="checkbox"/>	Remote ambient sensor <input type="checkbox"/>	Enthalpic <input type="checkbox"/>	Remote ambient sensor <input type="checkbox"/>
	Remote duct sensor <input type="checkbox"/>		Sensor incorporated at the thermostat <input type="checkbox"/>

D.- Select if you need extra fan with the freecooling

With extra fan Without extra fan

E.-Select the dampers configuration for the freecooling, as following. (In order to be adapted to the ducts of the installation)

E.1- Dampers position of the dampers on for freecooling WITHOUT extra fan:

The drawings are an upper view of the indoor unit and freecooling

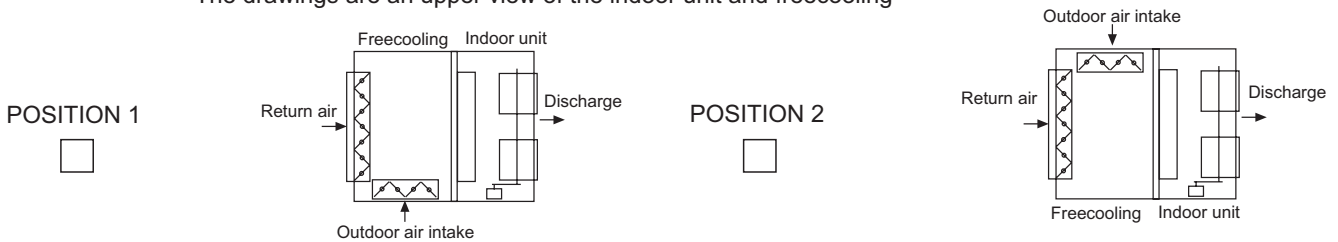

E.2- Dampers position of the dampers on for freecooling WITH extra fan:

The drawings are an upper view of the indoor unit and freecooling

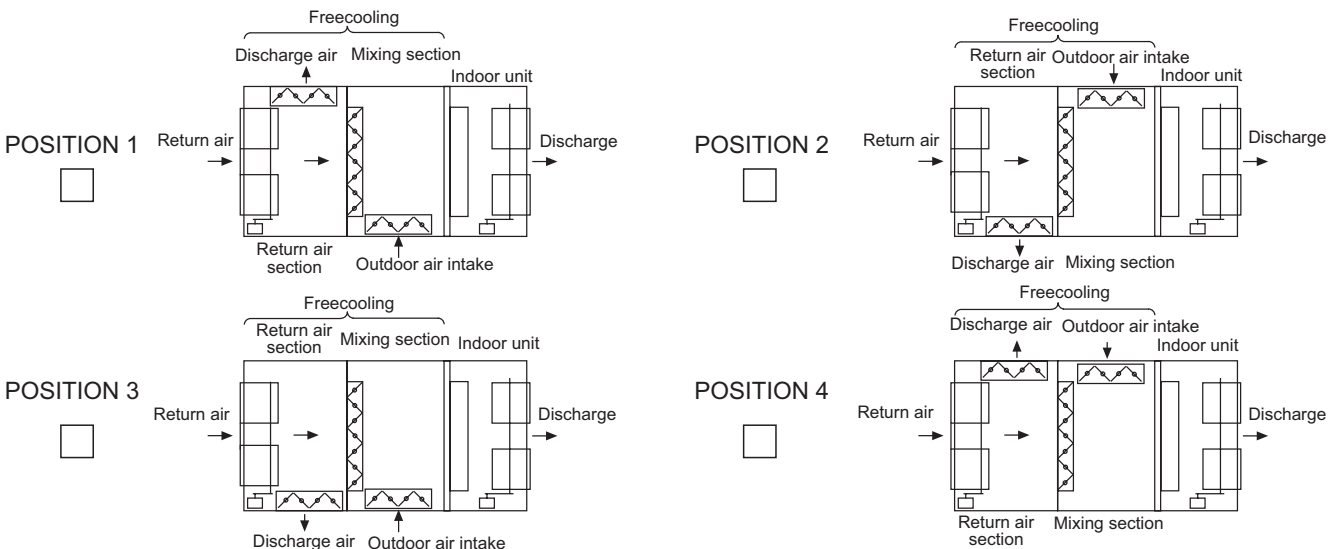

1.- GENERAL CHARACTERISTICS

1.5.- AVAILABLE OPTIONS

FREECOOLING

OUTLINE FOR ENTHALPIC FREECOOLING WITHOUT EXTRA FAN

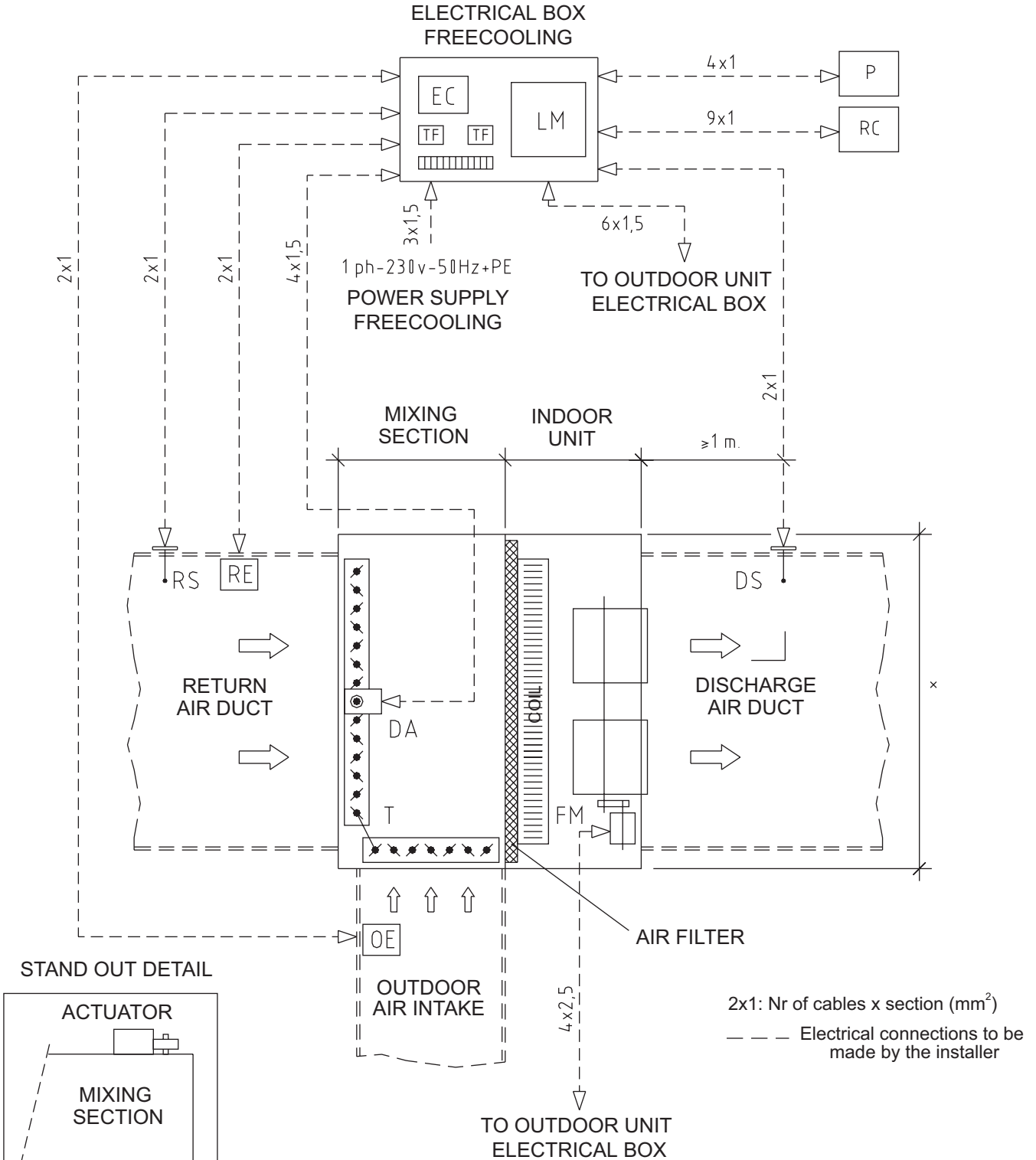

FREECOOLING OUTLINE FOR DOUBLE CIRCUIT UNITS

P - Potentiometer
EC - Enthalpy measure
LM - Logic module
TF - Transformer

RC - Remote controller
RE - Return Enthalpy sensor
RS - Return Temperature sensor
DS - Discharge Temperature sensor

DA - Damper Actuator
FM - Discharge fan motor
OE - Outside enthalpy sensor
T - Transmission

1.- GENERAL CHARACTERISTICS

1.6.- AVAILABLE OPTIONS

FREECOOLING

OUTLINE FOR ENTHALPIC FREECOOLING WITH EXTRA FAN

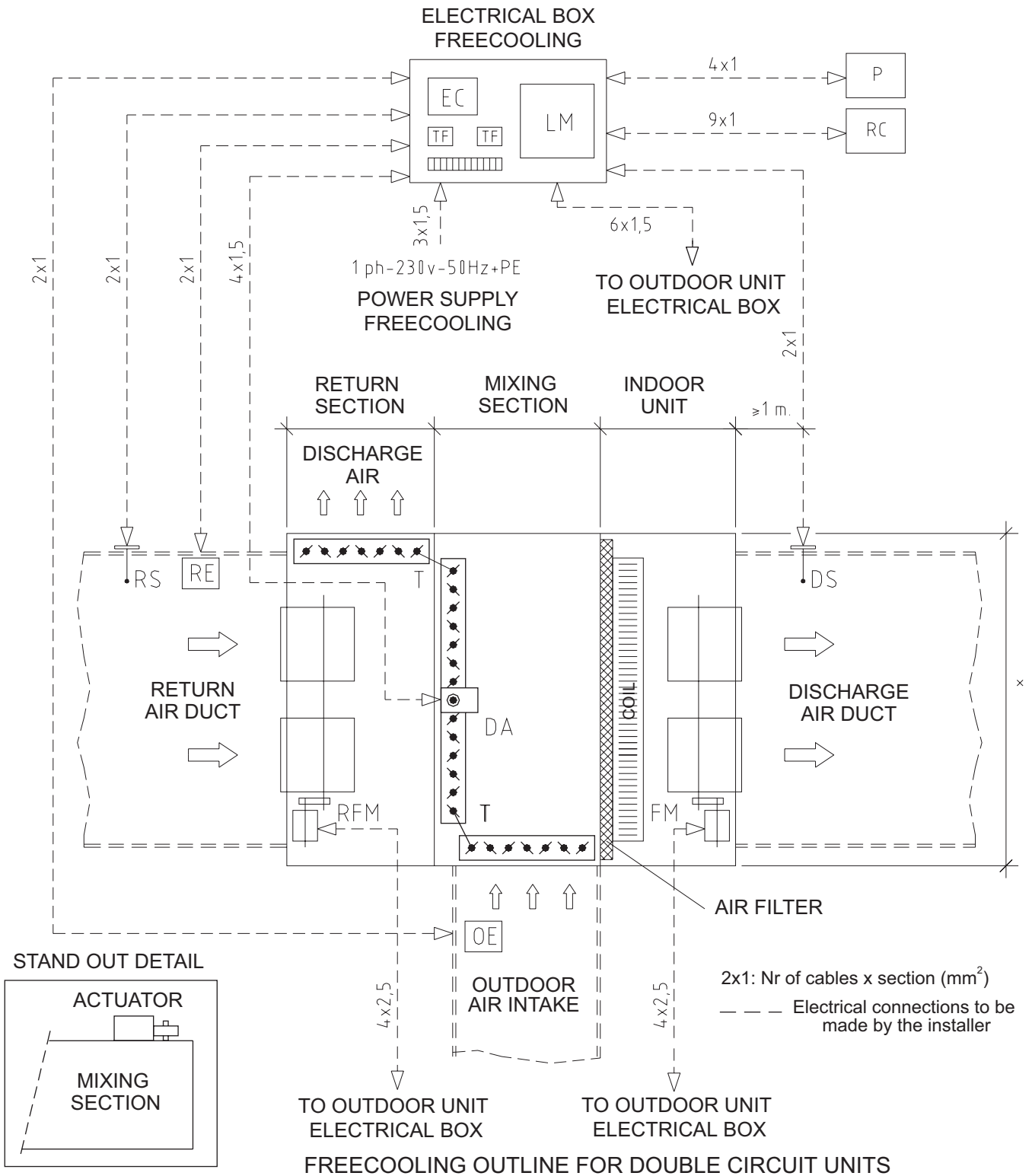

P - Potentiometer
EC - Enthalpy measure
LM - Logic module
TF - Transformer

RC - Remote controller
RE - Return Enthalpy sensor
RS - Return Temperature sensor
DS - Discharge Temperature sensor

DA - Damper Actuator
RFM - Return fan motor
FM - Discharge fan motor
OE - Outside enthalpy sensor
T - Transmission

1.- GENERAL CHARACTERISTICS

1.5.- AVAILABLE OPTIONS

FREECOOLING

OUTLINE FOR THERMOSTATIC FREECOOLING WITHOUT EXTRA FAN

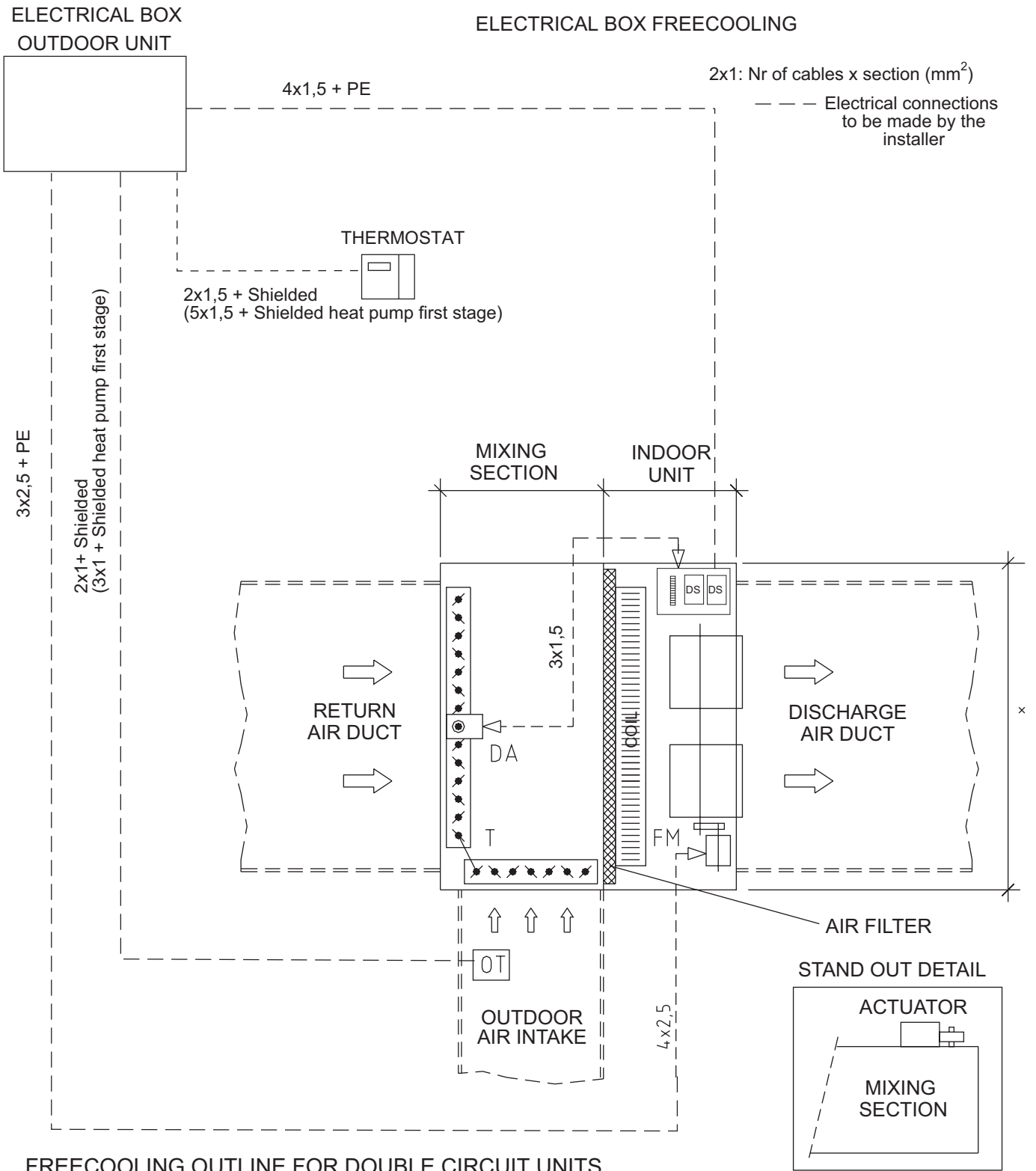

- DS - Discharge Temperature sensor
- DA - Damper Actuator
- FM - Discharge fan motor
- OT - Outside temperature sensor
- T - Transmission

1.- GENERAL CHARACTERISTICS

1.5.- AVAILABLE OPTIONS

FREECOOLING

OUTLINE FOR THERMOSTATIC FREECOOLING WITH EXTRA FAN

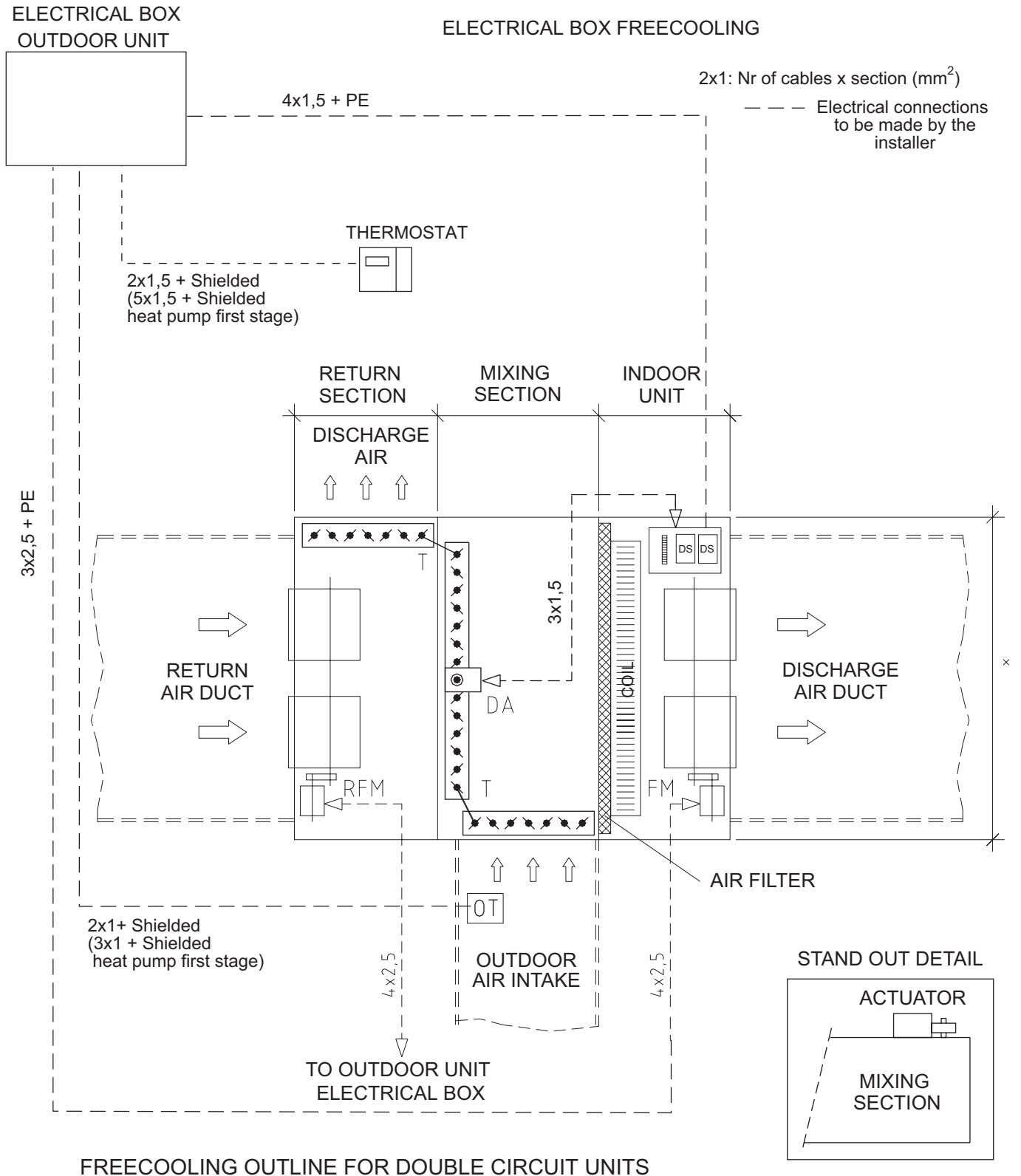

- DS - Discharge Temperature sensor
- DA - Damper Actuator
- RFM - Return fan motor
- FM - Discharge fan motor

- OT - Outside temperature sensor
- T - Transmission

1.- GENERAL CHARACTERISTICS

1.5.- AVAILABLE OPTIONS

FREECOOLING

DIMENSIONS FREECOOLING WITHOUT EXTRA FAN

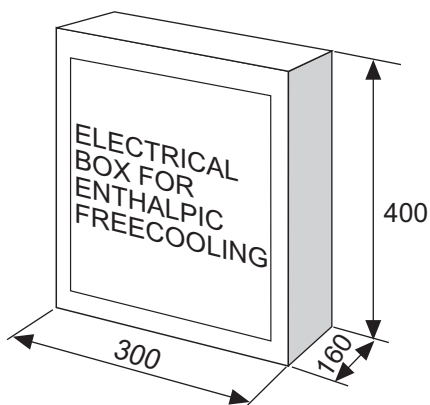
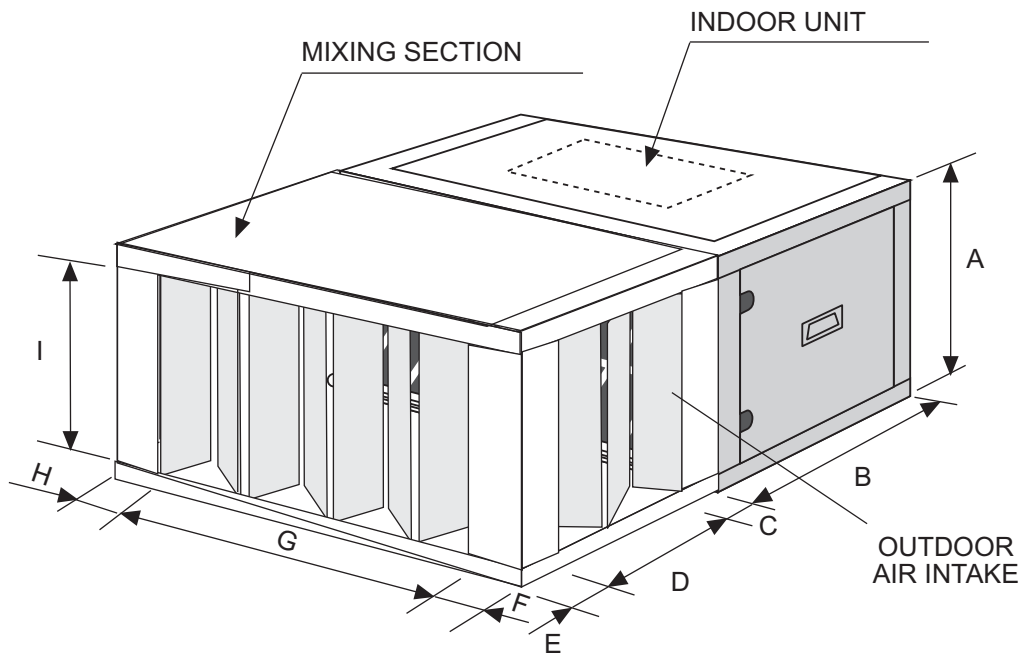

Electrical box for freecooling is supplied loose inside the mixing section.
Fix by the installer.

The damper position, can be different than the picture shows. See drawings.

	MODELS 22-24-28-32	MODEL 38
A	640	640
B	749	749
C	98	73,5
D	750	750
E	52	76,5
F	222	222
G	750	876
H	222	222
I	499	500
WEIGHTS Kg (*)	100	100

(*) Add to the unit's weight.

1.- GENERAL CHARACTERISTICS

1.5.- AVAILABLE OPTIONS

FREECOOLING

DIMENSIONS FREECOOLING WITHOUT EXTRA FAN

MODELS 44D-48D-56D-64D-76D

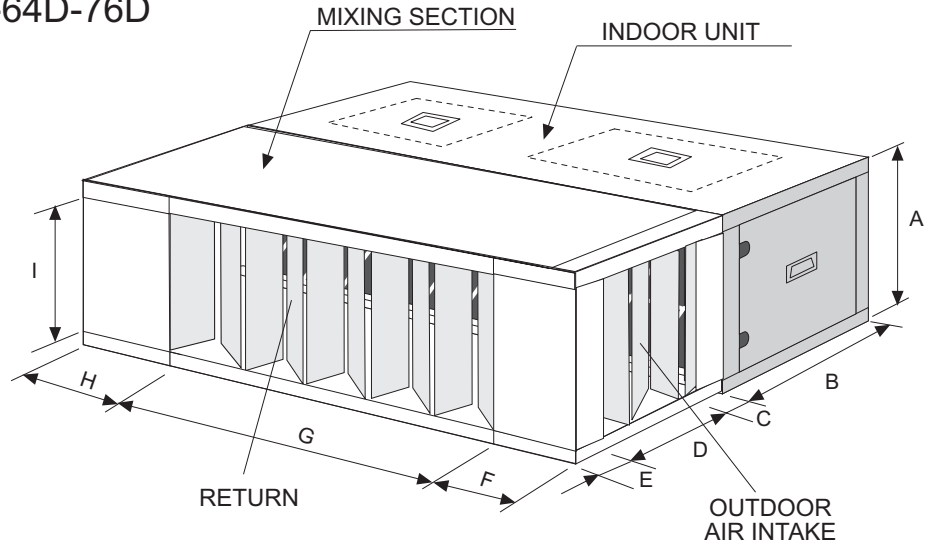

MODELS 86D-100D

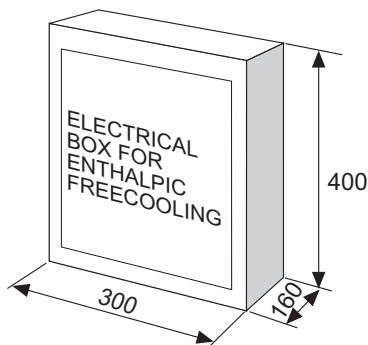
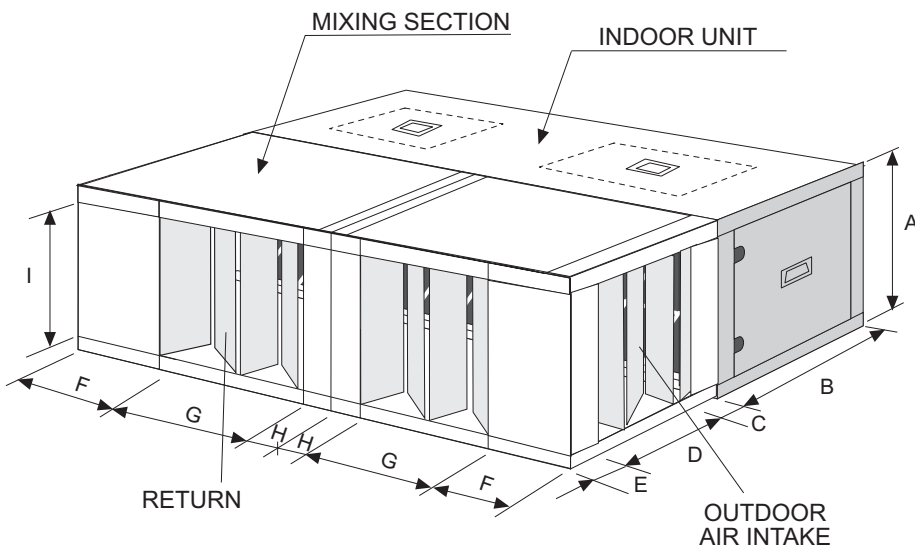

Electrical box for freecooling is supplied loose inside the mixing section.
Fix by the installer.

The damper position, can be different than the picture shows.
See drawings.

	MODELS 44-48-56-64	MODEL 76	MODELS 86-100
A	640	640	640
B	750	750	750
C	100,5	100,5	50
D	749	749	1000
E	50,5	50,5	150
F	250	312,5	233
G	1750	1875	1125
H	250	312,5	93
I	499	499	550
WEIGHTS Kg (*)	130	135	250

(*) Add to the unit's weight.

1.- GENERAL CHARACTERISTICS

1.5.- AVAILABLE OPTIONS

FREECOOLING

DIMENSIONS FREECOOLING WITH EXTRA FAN

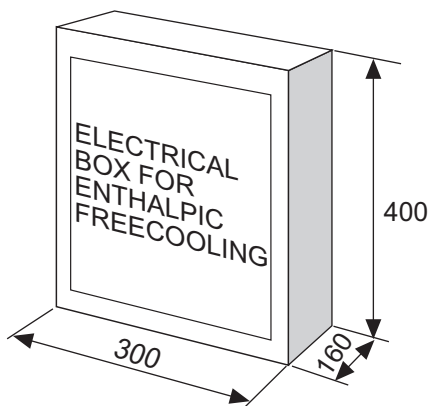
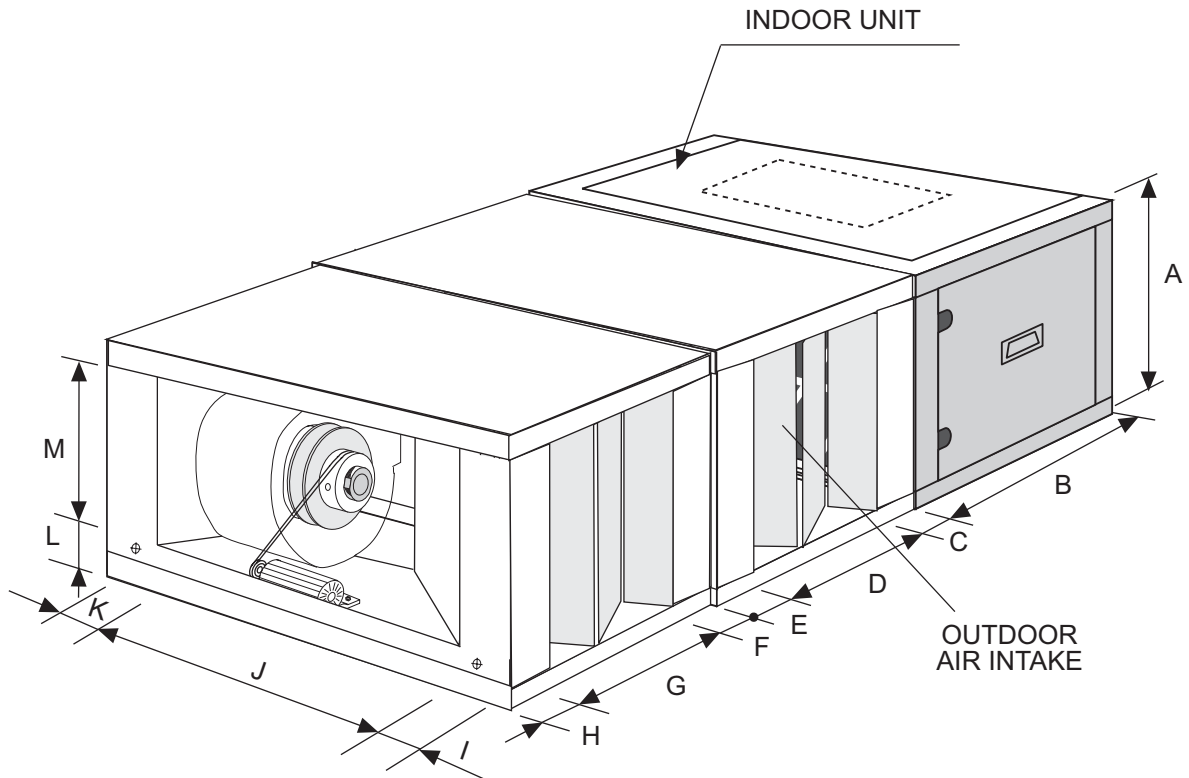

Electrical box for freecooling is supplied loose inside the mixing section.
Fix by the installer.

The damper position, can be different than the picture shows. See drawings.

	MODELS 22-24-28-32	MODEL 38
A	640	640
B	749	749
C	98	73,5
D	750	750
E	52	76,5
F	48	48
G	750	750
H	102	102
I	186	186
J	822	948
K	186	186
L	96,5	96,5
M	500	500
WEIGHTS Kg (*)	120	125

(*) Add to the unit's weight.

1.- GENERAL CHARACTERISTICS

1.5.- AVAILABLE OPTIONS

FREECOOLING

DIMENSIONS FREECOOLING WITH EXTRA FAN

MODELS 44D-48D-56D-64D-76D

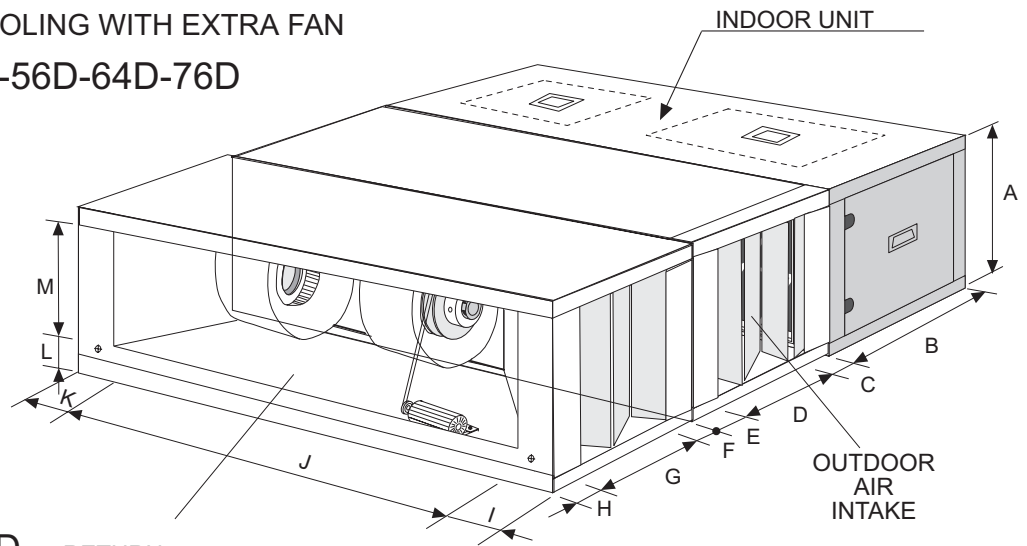

MODELS 86D-100D RETURN

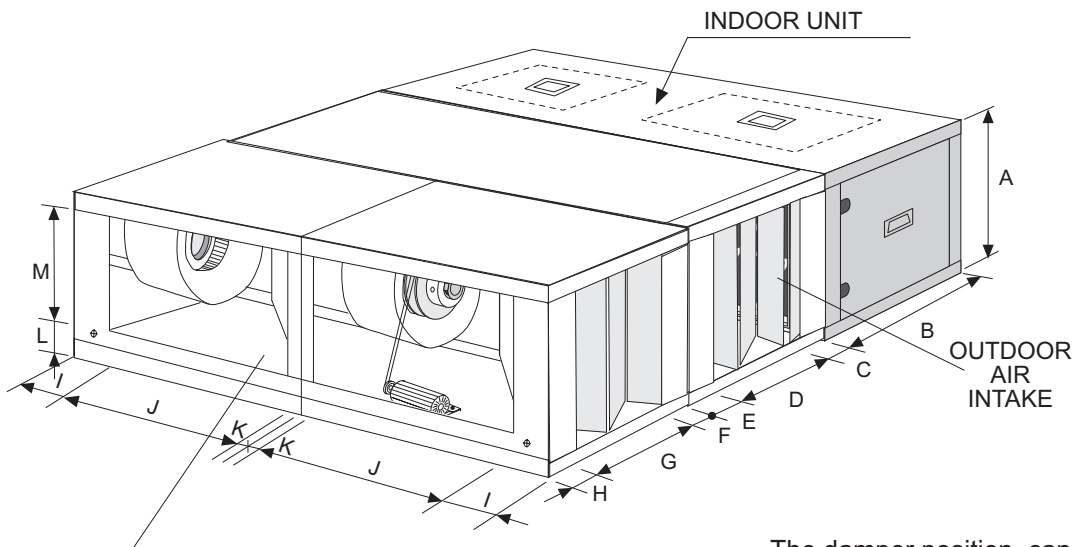

RETURN

The damper position, can be different than the picture shows. See drawings.

	MODELS 44-48-56-64	MODEL 76	MODELS 86-100
A	640	640	640
B	750	750	750
C	100,5	100,5	50
D	749	749	1000
E	50,5	50,5	150
F	48	48	45
G	750	750	1010
H	102	102	145
I	186	311	191,5
J	1878	1878	1204,5
K	186	311	15
L	96,5	96,5	88
M	500	500	500
WEIGHTS Kg (*)			
	195	200	320

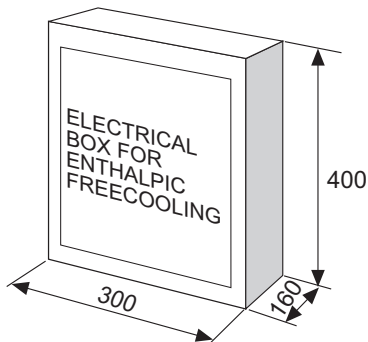

Electrical box for freecooling is supplied loose inside the mixing section.
Fix by the installer.

(*) Add to the unit's weight.

2.- INSTALLATION

2.1.- INSTALLATION GUIDELINES



All INSTALLATION, SERVICE and MAINTENANCE operations must be carried out by QUALIFIED PERSONNEL.

The unit must be transported in a HORIZONTAL POSITION on its metal bedplate profiles and TRANSPORTATION BLOCKS. Any other position may cause serious damage to the machine. When the unit is received, it should be checked to assure that there are no bumps or other damage, following the instructions on the packaging. If there is damage, the unit may be rejected by notifying the LENNOX Distribution Department and reporting why the machine is unacceptable on the transport agent's delivery notice. Any later complaint or claim made to the LENNOX Distribution Department, for this type of anomaly, cannot be considered under the Guarantee. Sufficient space must be allowed to facilitate placement of the unit.



When positioning the unit, be sure that the Rating Plate will always be visible since this data will be necessary to assure proper maintenance.

The units are designed to be installed with ducts, calculated by qualified technical staff. The joints to be used between ducts and the openings to the unit should be Elastic Joints. Avoid the use of BYPASS joints between the extraction air and input air in both the outdoor and indoor sections. The structure where the unit is placed must be able to support the weight of the unit during operation.

2.- INSTALLATION

2.2.- OPTIONAL OPERATIONS PRIOR TO UNIT INSTALLATION: CHANGE IN THE POSITION OF DISCHARGE FOR UNIT MODELS 22E-24E-28E-32E-38E-43E-50E

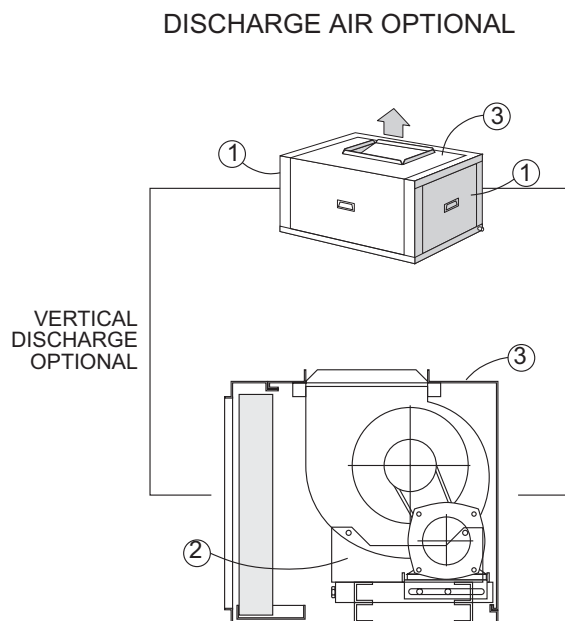
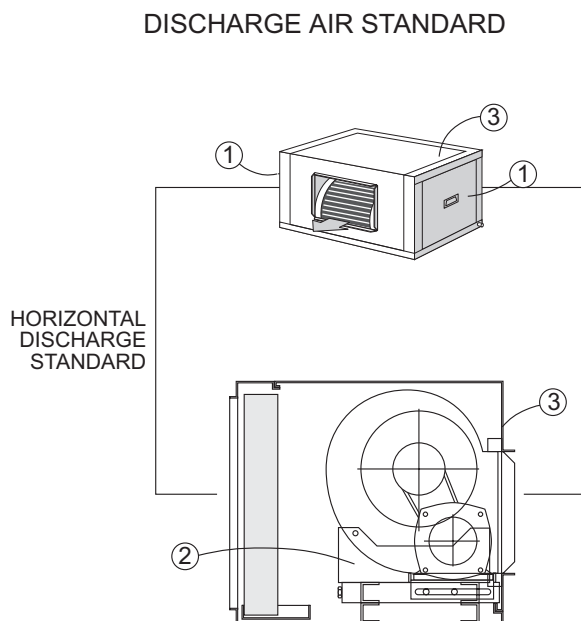

- 1 Check that unit is electrically disconnected.
- 2 Unscrew and remove side covers (1) and (3).
- 3 Loosen the transmission belts and disassemble them.
- 4 Remove the pulley from the fan axle.
- 5 Remove the fans and their supports (2).
- 6 Turn the fans until horizontal discharge position is reached.
- 7 Replace the fans on the supports (2) which should not moved.
- 8 Place the pulley on the fan axle on the side which coincides with the motor: assemble the belts and align them.
- 9 Tense the belts correctly.
- 10 Replace the upper and lateral covers and screw them down (1) y (3).

2.- INSTALLATION

2.2.- OPTIONAL OPERATIONS PRIOR TO UNIT INSTALLATION: CHANGE IN THE POSITION OF DISCHARGE FOR UNITS MODELS 44D-48D-56D-64D-76D-86D-100D

DISCHARGE AIR STANDARD

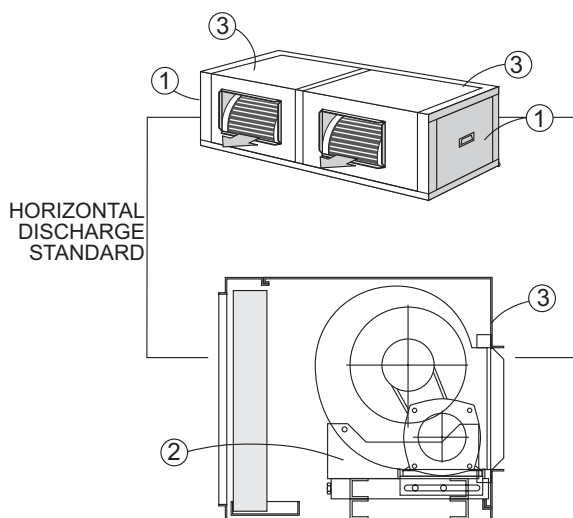

DISCHARGE AIR OPTIONAL

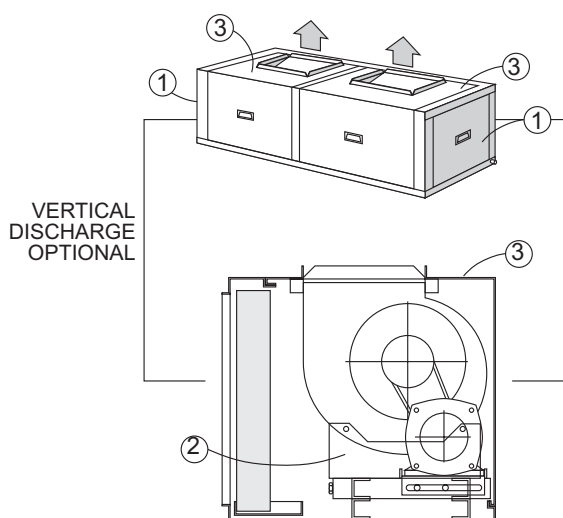

1 Check that unit is electrically disconnected.

2 Unscrew and remove side covers (1) and (3).

3 Loosen the transmission belts and disassemble them.

4 Remove the pulley from the fan axle.
ATTENTION!! Models 86D-100D; Unscrew the bottom bedplate.

5 Remove the fan and their supports (2).

6 Turn the fan until horizontal discharge position is reached.

7 Replace the fan on the supports (2) which should not moved.
ATTENTION!! Models 86D-100D; Screw the bottom bedplate.

8 Place the pulley on the fan axle on the side which coincides with the motor: assemble the belts and align them.

9 Tense the belts correctly.

10 Replace the upper and lateral covers and screw them down (1) y (3).

2.- INSTALLATION

2.3.- OPTIONAL OPERATIONS PRIOR TO UNIT INSTALLATION:

THE VENTILATION FOR LECK- LEHA- LEHK UNITS IS FORMED BY:

- 1.- Centrifugal fan (single or double).
- 2.- Activating motor.
- 3.- Fixed pulley at the fan.
- 4.- Variable pulley at the motor fan.
- 5.- transmission pulley or pulleys.
- 6.- Base of the motor with displacement system for tensioning of belts.
- 7.- Tensing screw.

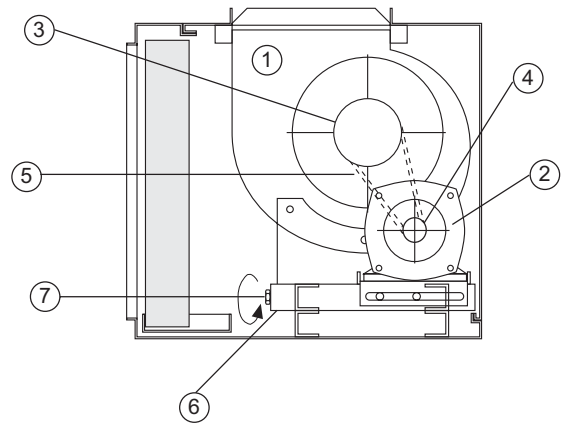

FLOW REGULATION IN THE FANS

The fan in the units have a variable pulley incorporated into the activating motor, by which it is possible to vary, when the fan is off its diameter to modify the air flow of the unit, as required.

1. Fixed part
2. Mobil part
3. Fixing screw

CLOSE PULLEY:

To increase the fan flow, turn the mobil part in direction "B" (Clock wise).

OPEN PULLEY:

To reduce the flow, turn in direction "A" (Unclock wise).

VARIABLE PULLEYS

SIMPLE PULLEY

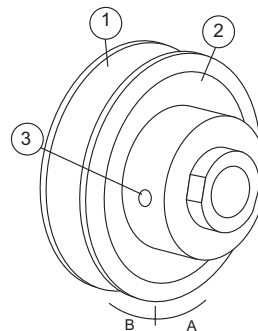

DOUBLE PULLEY

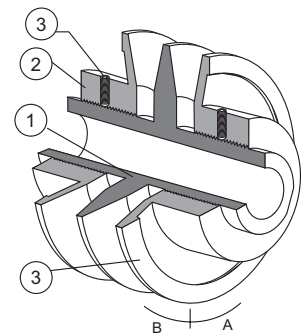

TENSION OF BELTS

The belts can be easily tensioned through the tensing screw incorporated into the bases of the motor of the transmitting units which also enables a good servicing to be carried out.

When the tensing screw is moved, the motor fan is moved to the sides in order to tension the pulley.

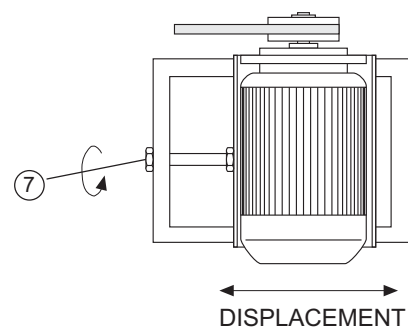

2.- INSTALLATION

2.4.- INSTALLATION CLEARANCES

Clearance around the unit for service and maintenance.

SERVICE SPACE

Space should be left free for access or servicing, to ease the installation of cables, drainage connections, electric installation and cleaning filters, as well as easy access to the unit.

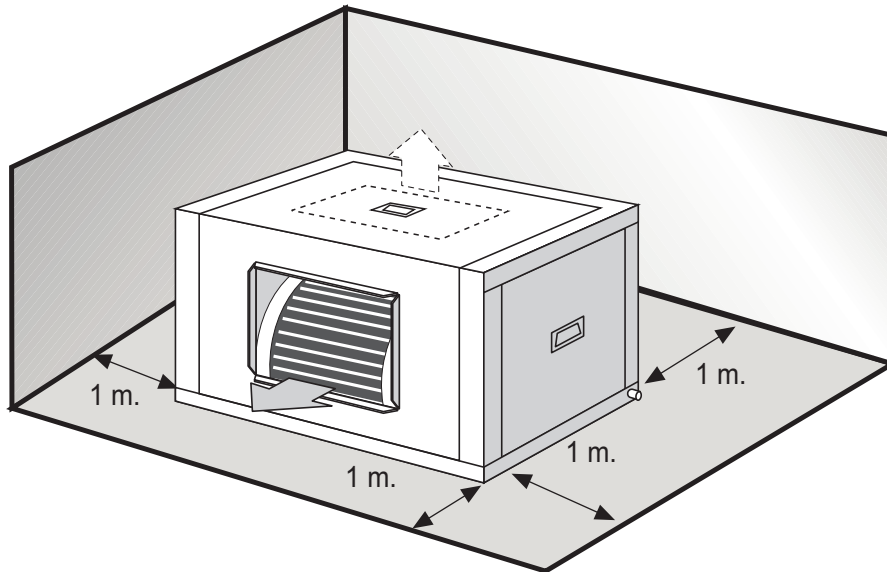

2.5.- DRAINS

All units have a 3/4" steel threaded drain pipe welded to the condensation tray.

Drainage pipes will be fitted for each tray through a siphon with a height difference of 80 mm. to avoid drainage problems from the depression formed by the fans. The pipes should have an inclination of 2% to ease drainage of condensation.

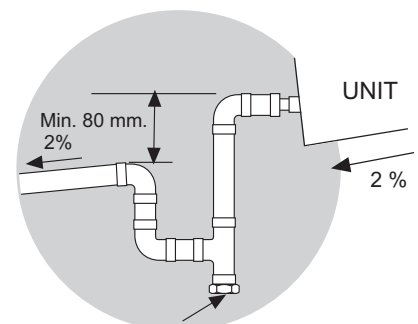

Inspection and cleaning stopper.

Also slightly tip the unit (2%) toward the drainage side. Check that the condensation trays are clean and free from dirt and other debris from the works and that water drains correctly.

2.- INSTALLATION

2.6- REFRIGERANT CONNECTIONS

The unit is supplied with gas and liquid lines sealed with copper covers inside the casing with possibility to install pipe lines horizontal or vertical.

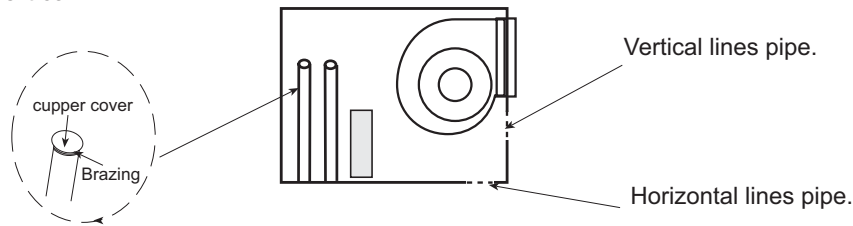

THE UNITS ARE SUPPLIED WITH NITROGEN GAS, THIS MUST BE REMOVED AND THEN PROCEED AS FOLLOW:

- 1° Remove the nitrogen gas, through the high and low 1/4" service ports, make vacuum as safety
 - 2° Remove the covers from connecting lines.
 - 3° Braze the piping connection lines.
- (When brazing refrigerant pipes, is necessary to supply nitrogen gas through the service ports into the pipes to remove the air).



DURING INSTALLATION OPERATIONS, KEEP GAS AND LIQUID PIPES COVERED, IN ORDER TO PREVENT HUMIDITY AND DIRT, GET INTO THEM.
TAKE SPECIAL CONCERN ABOUT REFRIGERANT PIPES ARE ISOLATED.
AVOID COLLAPSE ON PIPE LINES INSTALLATION.

2.7- ELECTRICAL CONNECTIONS



- BEFORE MAKING ANY ELECTRICAL CONNECTIONS, BE SURE THAT ALL CIRCUIT BREAKERS ARE OPEN.
- IN ORDER TO CARRY OUT THE ELECTRICAL CONNECTIONS, FOLLOW THE ELECTRICAL DIAGRAM SUPPLIED WITH THE UNIT.

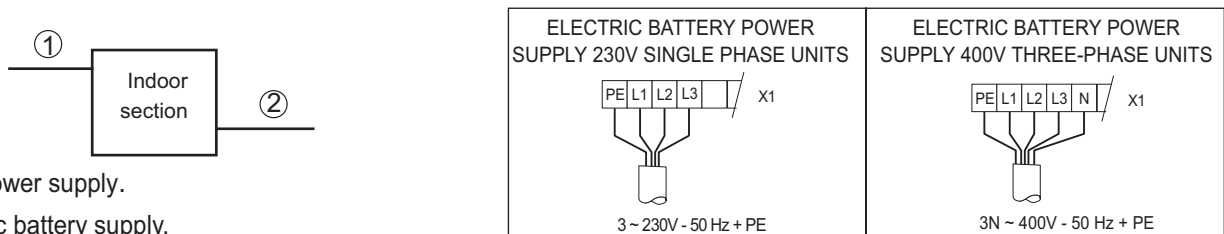

① Fan power supply.

② Electric battery supply.

UNIT MODEL	Nr. OF CABLES x SECTION (mm ²)		
	① Fan power supply	② Electric battery power supply	② Electric battery power supply
22E	4 x 1.5	4 x 10	4 x 4
24E	4 x 1.5	4 x 10	4 x 4
28E	4 x 1.5	4 x 10	4 x 4
32E	4 x 1.5	4 x 10	4 x 4
38E	4 x 1.5	4 x 10	4 x 4
43E	4 x 2.5	4 x 10	4 x 4
50E	4 x 2.5	4 x 10	4 x 4
44D	4 x 2.5	4 x 25	4 x 10
48D	4 x 2.5	4 x 25	4 x 10
56D	4 x 2.5	4 x 25	4 x 10
64D	4 x 2.5	4 x 25	4 x 10
76D	4 x 2.5	4 x 25	4 x 10
86D	4 x 2.5	4 x 25	4 x 10
100D	4 x 2.5	4 x 25	4 x 10

- The sections have been calculated for a length no longer than 50m and a voltage drop of 10V. Do not start the unit if the drop is greater than this.

3.- COMMISSIONING AND OPERATION

3.1.- PRELIMINARY CHECKS

- ① Check that drain pipe connections and their fixtures are secure and that the level of the unit is tipped toward the drain.
- ② Inspect the state of the ducts and grilles (clean and open grilles, no breaks in the duct, etc.).
- ③ Check that the power supply is the same as stated on the Rating Plate which is in agreement with the electrical diagram for the unit and that cable sizes are correct.
Check that tightness of the electrical connections to their terminals and to ground.
- ④ Inspect the Air Filter, which should be in its housing and correctly positioned (the metal grille should be toward the inside).
- ⑤ Check **with your hand** that the fan turns freely.

FIGURE FOR THE STANDARD UNIT CONFIGURATION FOR MODELS:
44D-48D-56D-64D-76D

LOCATION

The unit can be installed outside. If it is installed, air entry and exit ducts should be fitted. The indoor unit should be assembled on bases previously made and stood on absorbent and antivibrating material to avoid the vibrations being transmitted to the structure of the building.

DISCHARGE IN THE MODELS UNITS **44D-48D-56D-64D-76D**

Always to be done through a common duct or plenum

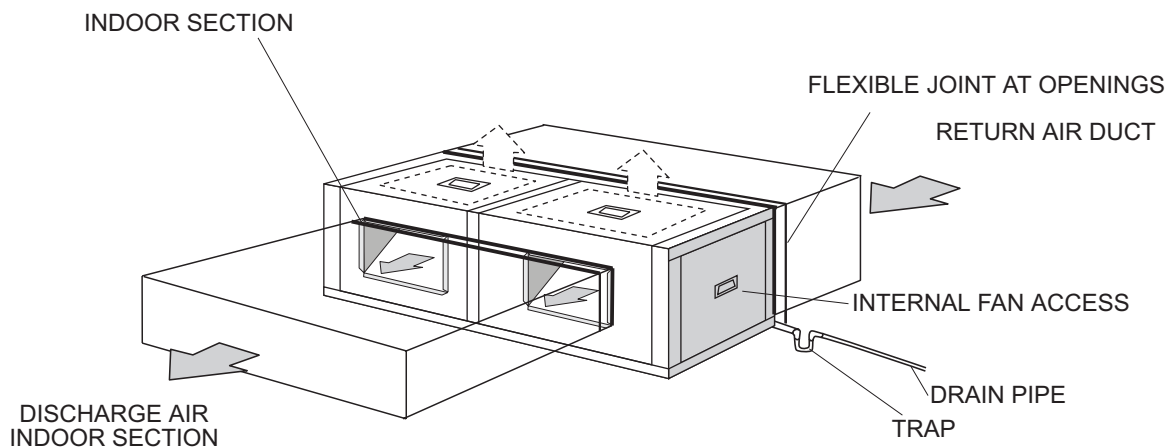

4.- MAINTENANCE

4.1.- PREVENTIVE MAINTENANCE



PREVENTIVE MAINTENANCE PREVENTS COSTLY REPAIRS.
BECAUSE OF THIS PERIODIC INSPECTIONS ARE REQUIRED.

-GENERAL STATE OF THE CASING :

Furniture, paint, deterioration due to bumps, rust spots, leveling and supporting, state of the shock absorbers, if installed, screwed panels, etc.

- ELECTRICAL CONNECTIONS :

State of hoses, tightness of screws, grounding, current draw of the compressor and fans and checking that the unit is receiving the correct voltage.

- COOLING CIRCUIT :

Check that pressure values are correct and that there are no leaks. Check that there is no damage to the pipe insulation, that the state of the batteries is correct and that there are no chips or clogs retained by the air flow, etc.

- DRAINS :

Check that water drains correctly and that the drain trays are clean.

- FAN :

Check that fans turn freely and in the correct direction without excessive noises.

- AIR FILTER :

The air filter can be removed through the side by sliding it over the rail or down. (See figure).

For down removal, remove the two profiles supporting it (depending on the model) which are under the filter guide rail and screwed into the unit.

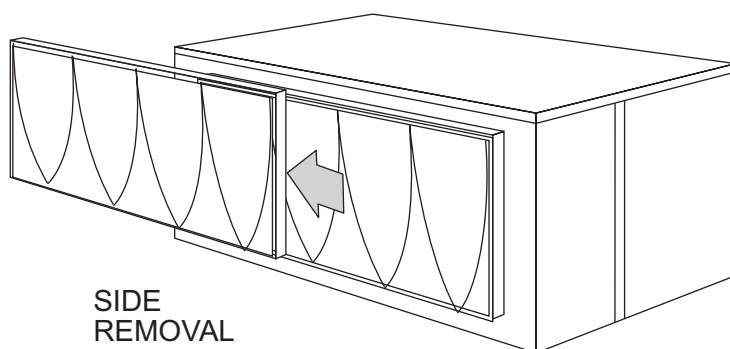

The filter should be cleaned with a vacuum cleaner or washed in soapy water.

The frequency for cleaning or changing the air filters will depend on the quality air in the area (fumes, vapors, suspended dust particles, etc.).

Remember that the metal grille should always be toward the inside of the unit.



Remember that the Control Panel may program a notification parameter, for cleaning or replacement of air filters depending on the number of hours of fan operation in the indoor section.

BELGIUM :
LUXEMBOURG :

LENNOX BENELUX N.V./S.A.
tél. : + 32 3 633 30 45
fax : + 32 3 633 00 89
e-mail : info.be@lennoxbenelux.com

CZECH REPUBLIC :

JANKA LENNOX a.s.
tél. : + 420 2 510 88 111
fax : + 420 2 579 10 393
e-mail : janka@janka.cz

FRANCE :

LENNOX FRANCE
tél. : + 33 1 64 76 23 23
fax : + 33 1 64 76 35 75
e-mail : marketing.france@lennoxfrance.com

GERMANY:

LENNOX DEUTSCHLAND GmbH
tél. : + 49 69 42 09 79 0
fax : + 49 69 42 09 79 40
e-mail : info.de@lennoxdeutschland.com

NETHERLANDS :

LENNOX BENELUX B.V.
tél. : + 31 33 2471 800
fax : + 31 33 2459 220
e-mail : info@lennoxbenelux.com

POLAND :

LENNOX POLSKA Sp. z o.o.
tél. : + 48 22 832 26 61
fax : + 48 22 832 26 62
e-mail : info@lennoxpolska.pl

PORTUGAL :

LENNOX PORTUGAL LDA.
tél. : + 351 22 998 33 70
fax : + 351 22 998 33 79
e-mail : info@lennoxportugal.com

RUSSIA :

LENNOX DISTRIBUTION MOSCOW
tél. : + 7 095 933 29 55
fax : + 7 095 926 56 50
e-mail : lennox.dist.moscow@co.ru

SLOVAKIA :

LENNOX SLOVENSKO s.r.o.
tél. : + 421 7 44 87 19 27
fax : + 421 7 44 88 64 72
email : lennoxslovensko@lennox.sk

SPAIN:

LENNOX REFAC S.A.
tél. : + 34 915 40 18 10
fax : + 34 915 42 84 04
e-mail : marketing@lennox-refac.com

UKRAINE :

LENNOX DISTRIBUTION KIEV
tél. : + 380 44 461 87 75
fax : + 380 44 461 87 75
e-mail : lennoxua@i.kiev.ua

**UNITED KINGDOM,
IRELAND:**

LENNOX INDUSTRIES Ltd
tél. : + 44 1604 669100
fax : + 44 1604 669150
e-mail : ukmarketing@lennoxind.com

**OTHER EUROPEAN COUNTRIES,
AFRICA,
MIDDLE-EAST :**

LENNOX DISTRIBUTION
tél. : + 33 4 72 23 20 14
fax : + 33 4 72 23 20 28
e-mail : marketing@lennoxdist.com



LENNOX®

www.lennox europe.com