

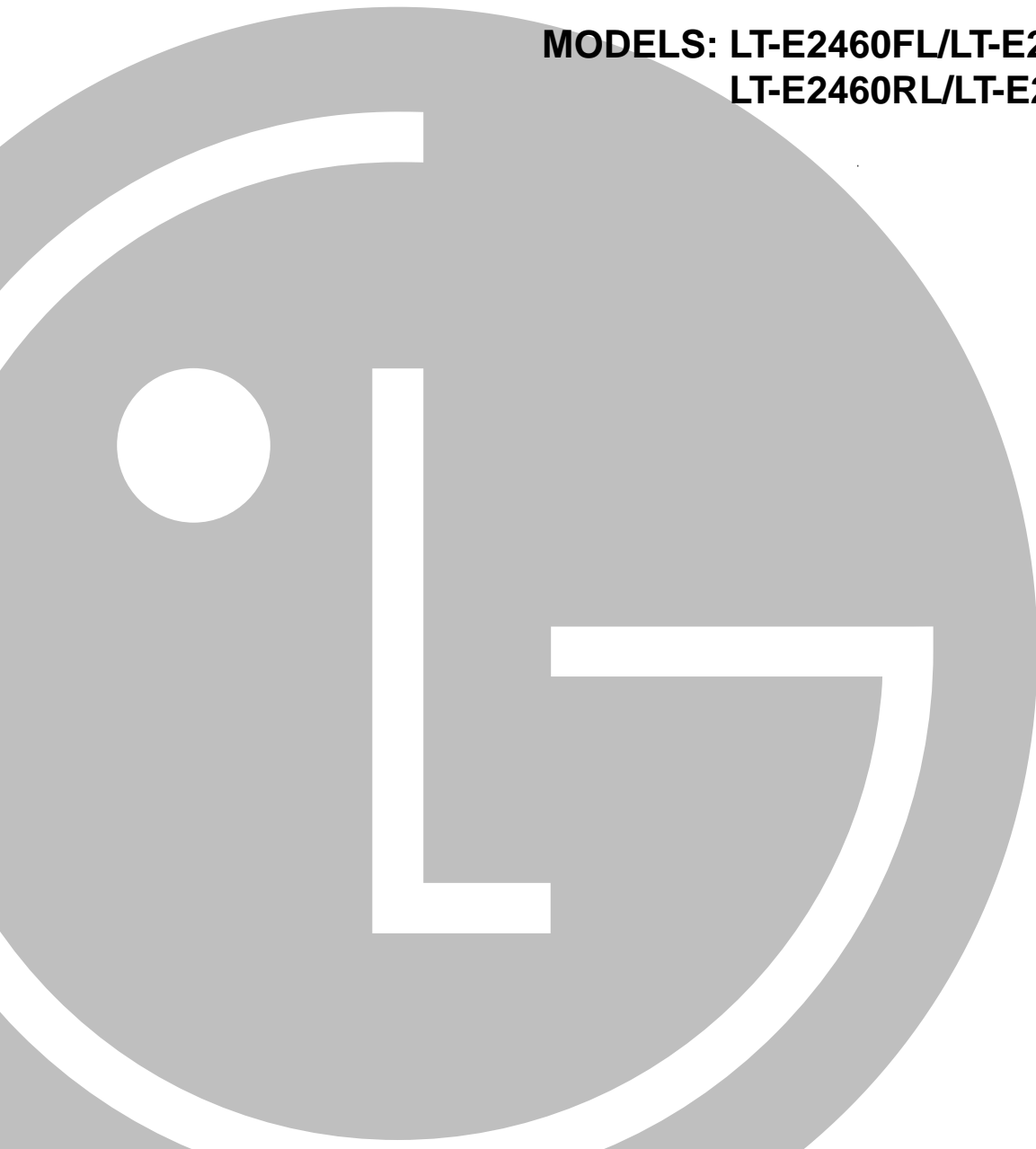

# Ceiling Cassette Air Conditioner **SERVICE MANUAL**

**MODELS: LT-E2460FL/LT-E2460FA  
LT-E2460RL/LT-E2460RA**



# Contents

---

<b>Functions .....</b>	<b>3</b>
<b>Product Specifications (Cooling).....</b>	<b>5</b>
<b>Dimensions .....</b>	<b>6</b>
<b>Refrigeration Cycle Diagram .....</b>	<b>8</b>
<b>Wiring Diagram .....</b>	<b>9</b>
<b>Operation Details .....</b>	<b>10</b>
<b>Installation of Indoor, Outdoor Unit .....</b>	<b>13</b>
<b>2-way Valve, 3-way Valve .....</b>	<b>28</b>
<b>Cycle Troubleshooting Guide .....</b>	<b>33</b>
<b>Electronic Parts Troubleshooting Guide .....</b>	<b>34</b>
<b>Electronic Control Device .....</b>	<b>37</b>
<b>Schematic Diagram .....</b>	<b>38</b>
<b>Exploded View and Replacement Parts List .....</b>	<b>39</b>

# Functions

---

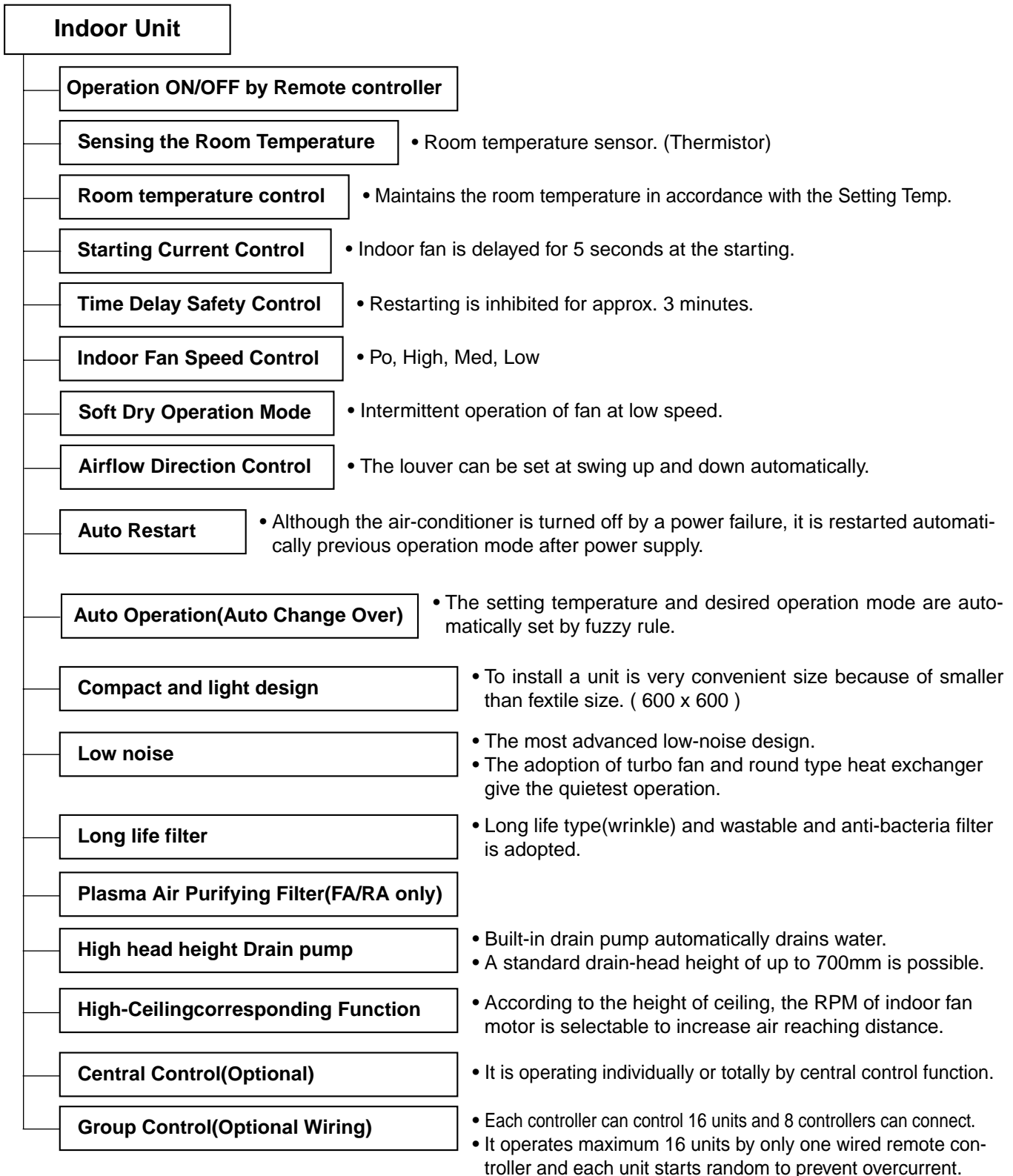

# Remote Controller

## Operation ON/OFF



## Operation Mode Selection

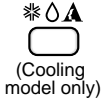

(Cooling model only)

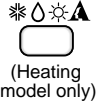

(Heating model only)

Cooling Operation Mode ( ❄ )  
Heating Operation Mode ( ☀ )

Soft Dry Operation Mode ( 💧 )  
Auto Operation Mode ( ▲ )

## Fan Speed Selection



**LO** (Low)

**MED** (Med)

**HI** (High)

**Po**

**AUTO**

## Room Temperature Display



: High:39°C ↔ LOW:11°C

## Temperature Setting



Cooling [ Down to 18°C  
Up to 30°C

Heating [ Down to 16°C  
Up to 30°C

## Setting the Timer

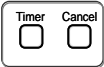

## Weekly Program

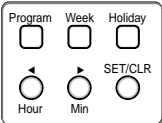

## Fan Operation Mode



: Fan Operates without cooling & heating

# Product Specifications (Cooling)

Model			LT-E2460FL/FA	LT-E2460RL/RA
Power Supply		ø, V, Hz	1, 220-240, 50	1, 220-240, 50
Capacity	Cooling	kcal/h(W)	-	-
		Btu/h	23,300	23,300
	Heating	kcal/h(W)	-	-
		Btu/h	-	23,500
Input	Cooling	W	2,400	2,600
	Heating	W	-	-
Running Current	Cooling	A	11.2	12
	Heating	A	-	-
E. E. R		kcal/h(W)	2.19	-
C.O.P		W/W	-	-
Air Circulation	Indoor	m <sup>3</sup> /min	15	15
	Outdoor	m <sup>3</sup> /min	50	50
Moisture Removal		// h	1.9	-
Feature	Air-Flow Direction Control		O	O
	Heating Operation Mode		X	O
	Fan Speeds (steps)		4	4
	Auto Operation (Changeover)		O	O
	Forced Operation		O	O
	Jet Cool		O	O
	Soft Dry Operation		O	O
	Timer Delay Safety Function		O	O
	Air Deflection (Way)		4	4
	Self Diagnosis		O	O
	Hot start		X	O
	Auto Restart		O	O
	Air refresh (Hole)		O	O
	High Ceiling		O	O
	Group Control (Optional wiring)		O	O
	Central Control		Optional	Optional
Wired remote controller (with weekly Program)		O	O	
Plasma A/Cleaner		X / O	X / O	
Refrigerant(R-410A) Charge		g	1,480	1,560
Dimensions (W x D x H)	Indoor	mm	570 x 570 x 269	570 x 570 x 269
	Panel	mm	670 x 670 x 30	670 x 670 x 30
	Outdoor	mm	870 x 655 x 320	870 x 655 x 320
Net Weight	Indoor	kg	20	20
	Outdoor	kg	60	60
Main Power Cord		AWG#:P*mm <sup>2</sup>	14 : 3*2.5	14 : 3*2.5
Connection Cable		AWG#:P*mm <sup>2</sup>	18 : 4*0.75	18 : 4*0.75
Service Valve	Liquid	(inch)	1/4 (6.35mm)	1/4 (6.35mm)
	Gas	(inch)	1/2 (12.7mm)	1/2 (12.7mm)
Installation Pipe	Max. Length	(m)	30	-
	Max. Elevation	(m)	30	-
	Insulation(material/thickness)		Foam PE/5mm	Foam PE/5mm
Drain Hose(I.D/O.D)		mm	Ø25/32	Ø25/32

# Dimensions

## (1) Indoor Unit

- Model : LT-E2460FL/FA, LT-E2460RL/FL

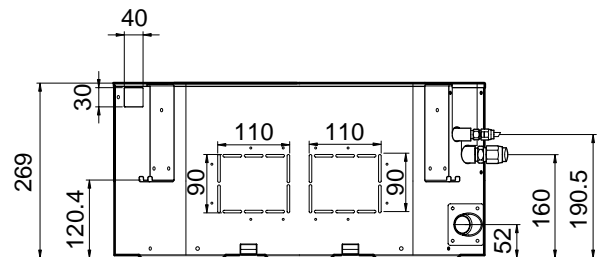
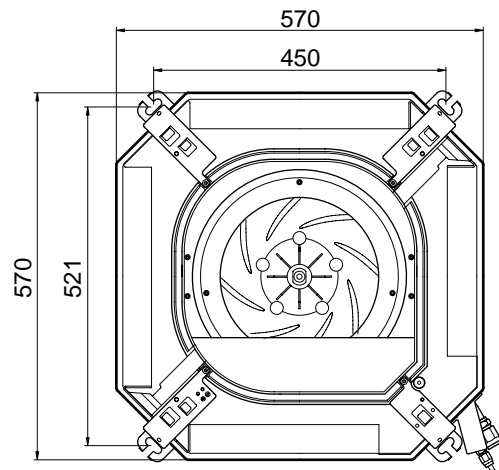
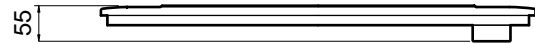
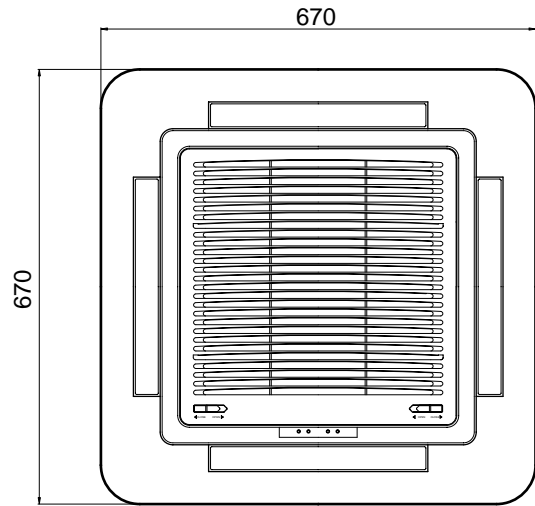
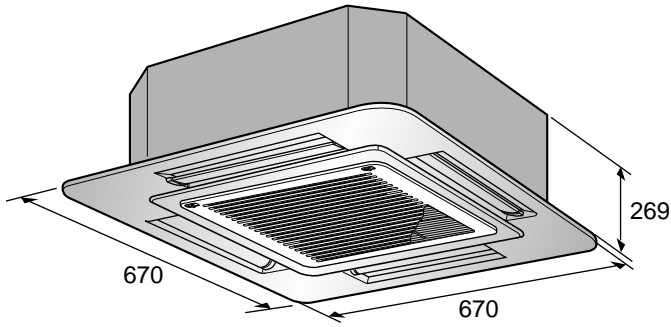

## (2) Outdoor Unit

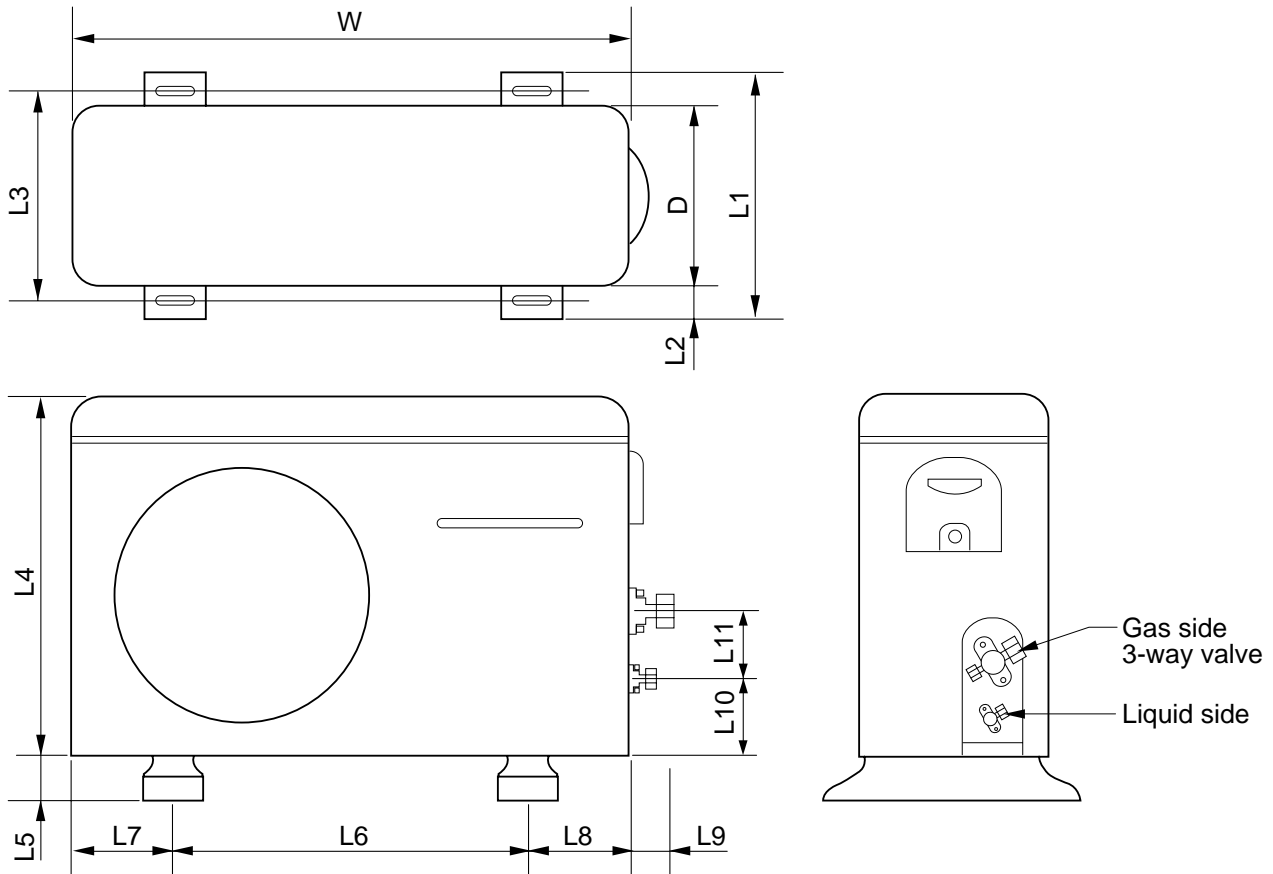

DIM \ MODEL		MODEL	
		LT-E2460FL/FA LT-E2460RL/RA	
W	mm	870	
H	mm	655	
D	mm	320	
L1	mm	370	
L2	mm	25	
L3	mm	340	
L4	mm	630	
L5	mm	25	
L6	mm	546	
L7	mm	162	
L8	mm	162	
L9	mm	54	
L10	mm	74.5	
L11	mm	79	

# Refrigeration Cycle Diagram

## • COOLING ONLY

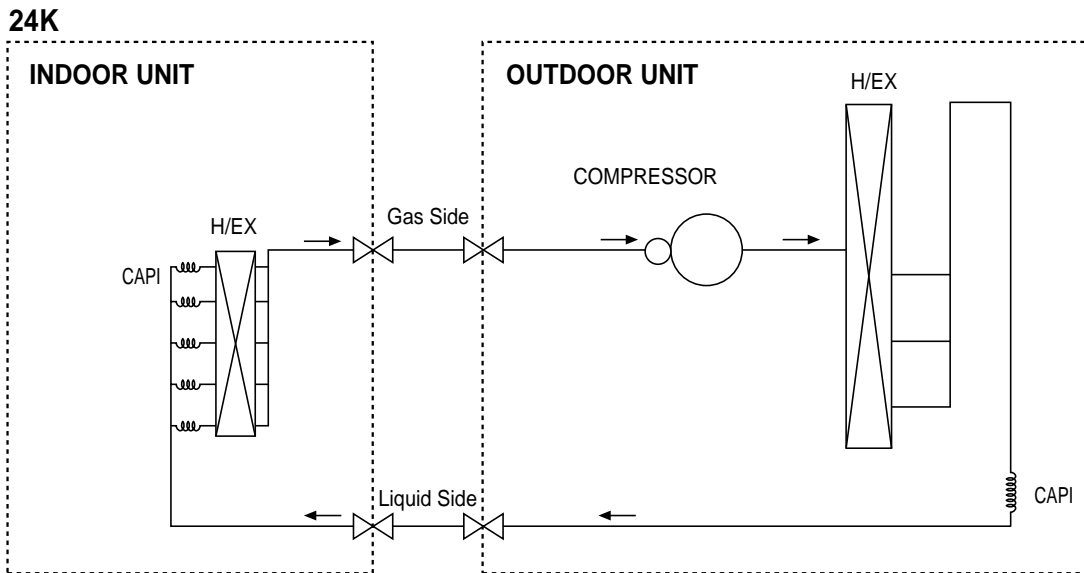

## • HEAT PUMP

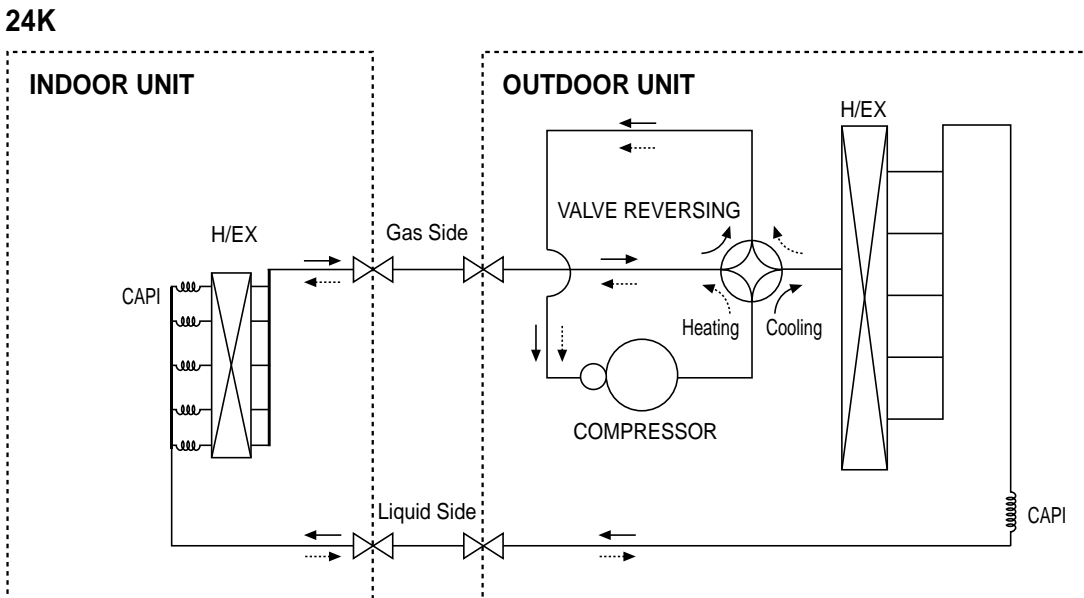

Capacity	Pipe Size		Length (m)		Elevation (m)		* Additional refrigerant (g/m)
	GAS	LIQUID	Rated	Max.	Rated	Max.	
24K	1/4"	1/2"	7.5	30	5	15	30

- Rated performance for refrigerant line length of: 7.5m
- If 24K Capacity is installed at a distance of 15m, 225g of refrigerant should be added .....(15-7.5)x30g



# Wiring Diagram

## • COOLING ONLY

Models : LT-E2460FL/FA

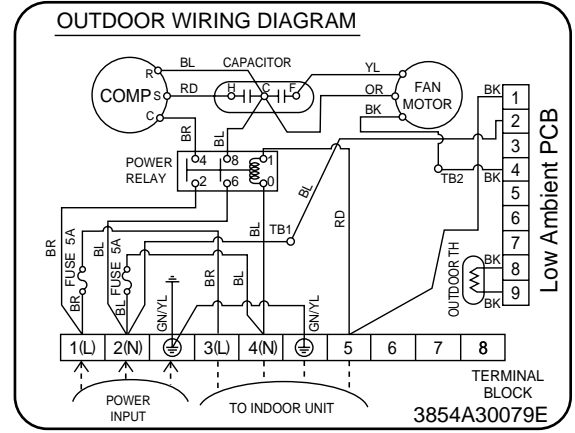
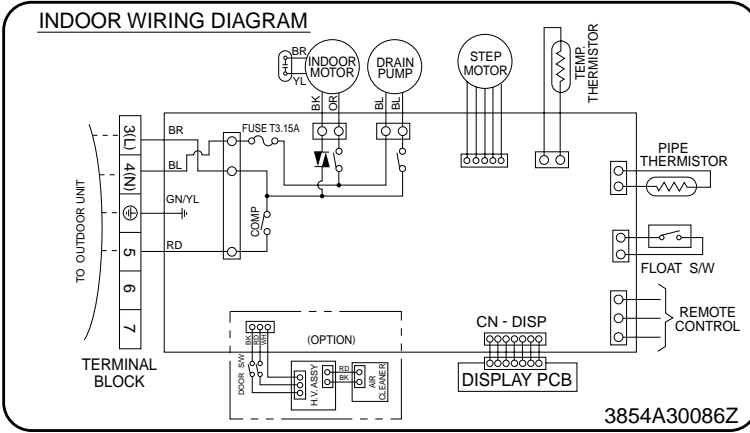

## • HEAT PUMP

Models : LT-E2460RL/RA

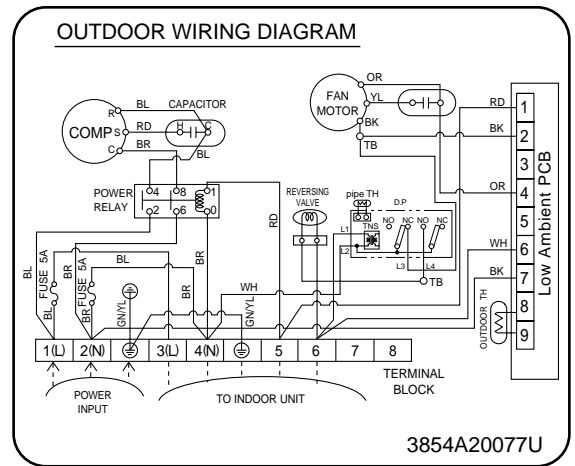
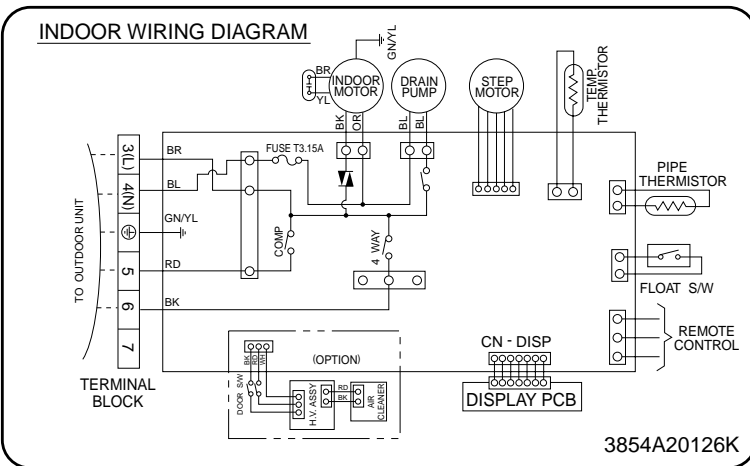

# Operation Details

## (1) The function of main control

### 1. Time Delay Safety Control

- 3min... The compressor is ceased for 3minutes to balance the pressure in the refrigeration cycle.  
(Protection of compressor)
- 5sec... Vertical louvers are delayed for 5 secs to be opened to prevent the frictional sound between louver and air flow.
- 30sec... The 4-way valve is ceased for 30sec. to prevent abnormal noise when the Heating operation is OFF or switched to the other operation mode while compress is off.  
While compressor is running, it takes 3~5 seconds to switch.

### 2. Auto Swing Control

- This function is to swing the louver up and down automatically.

### 3. Air-Filter Checking Control

- 'Filter' sign will appear on the remote controller display and main body display when an air-filter is polluted. Then clean the air-filter referring to Owners Manual.

### 4. Soft-Dry Operation

- The indoor fan speed is automatically set to the low, and fan speed control is not available because of already being set to the best speed for Dry Operation by Micom Control.

### 5. Cooling Mode Operation

- When selecting the Cooling(✳) Mode Operation, the unit will operate according to the setting by the remote controller and the operation diagram is as follows.

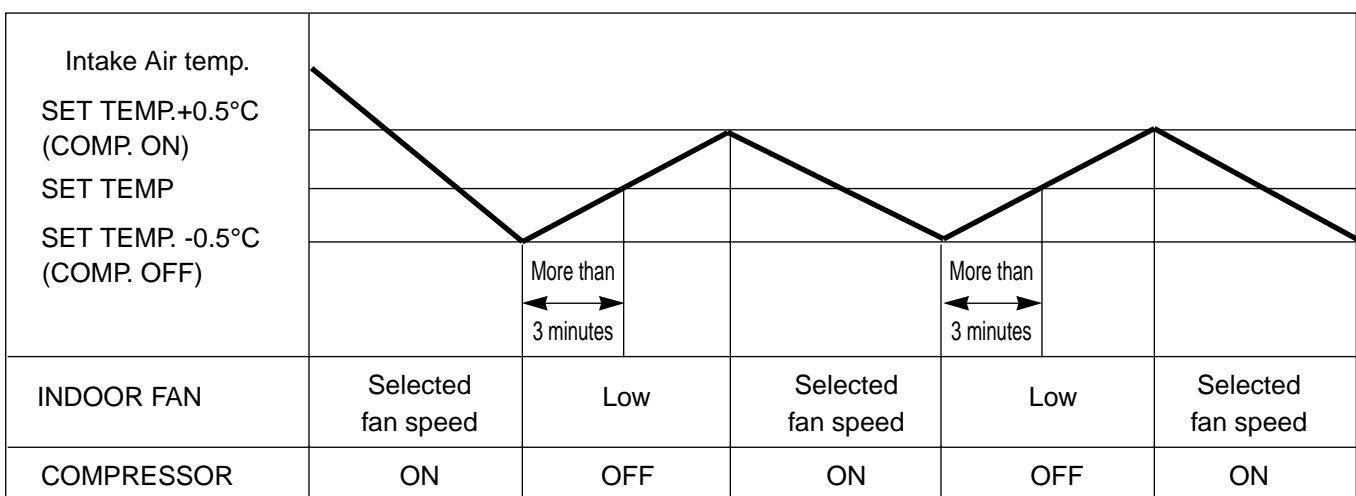

## 6. Heating Mode Operation

The unit will operate according to the setting by the remote controller and the operation diagram is shown as follows.

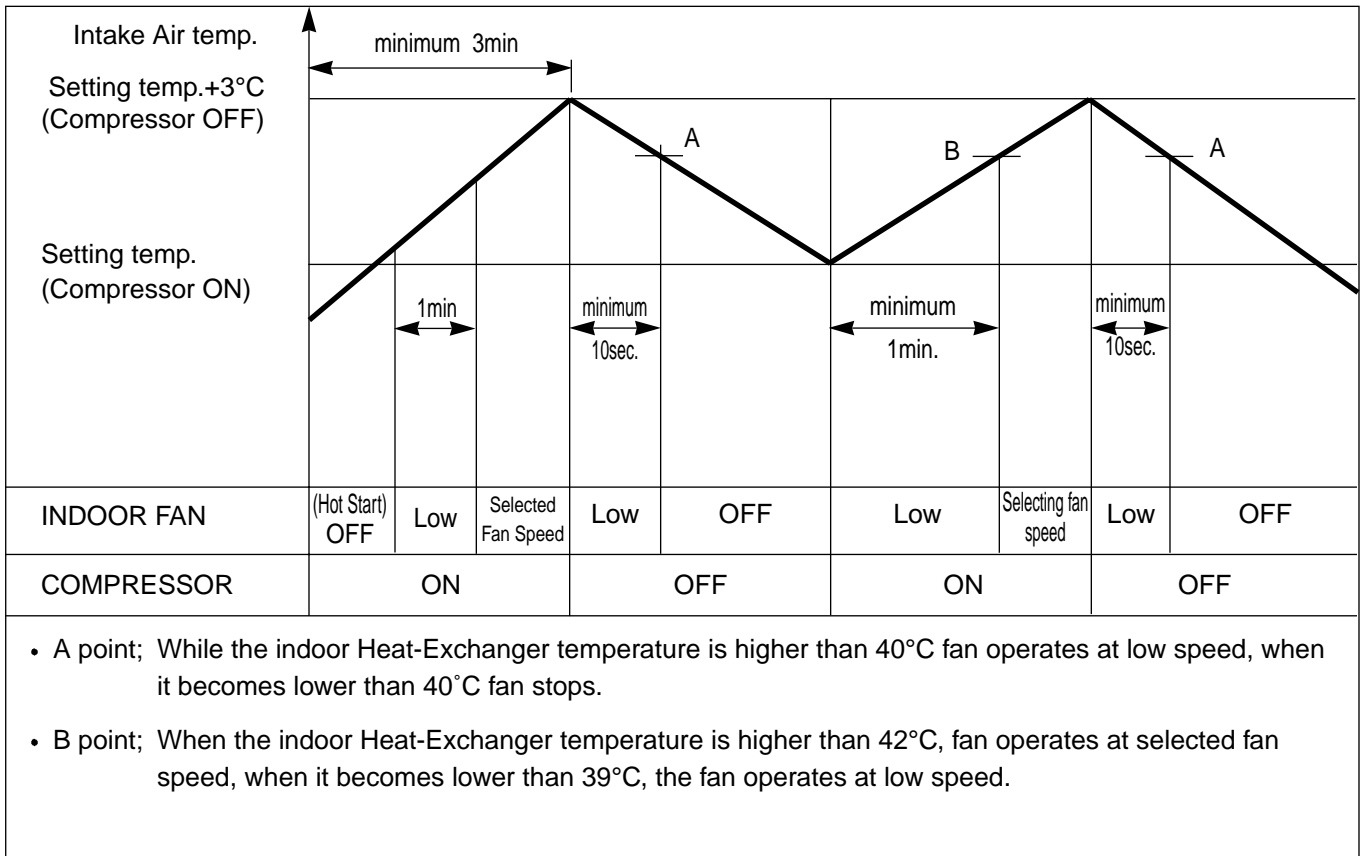

## 7. Hot-Start Control

- The indoor fan stops until the evaporator piping temperature reaches to 25°C.
- If the evaporator piping temperature drops below 22°C, indoor fan stops again.
- The operation diagram is as follows.

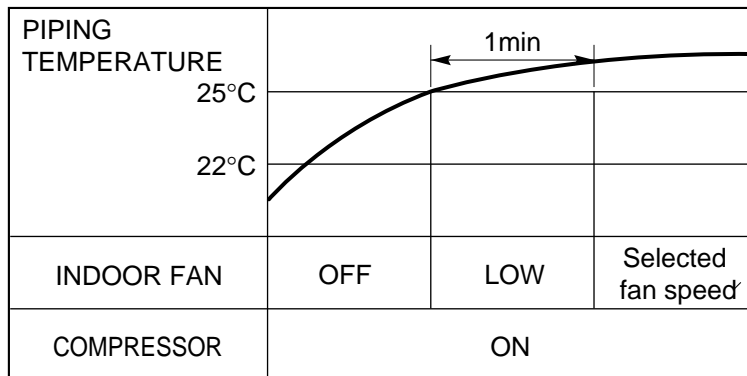

## 8. Defrost Control

- Defrost control is available 45 minutes later since heating mode operation started, and it will not prolong over 10 minutes.
- Defrost control is carried out when the outdoor pipe temp. falls below  $-6^{\circ}\text{C}$  for more than 3 minutes after 45 minutes passed from starting of heating operation.
- Defrost ends after 10 minutes passed from starting of defrost operation or when the outdoor pipe temp. rises over  $12^{\circ}\text{C}$  after 5 minutes passed from starting of defrost.

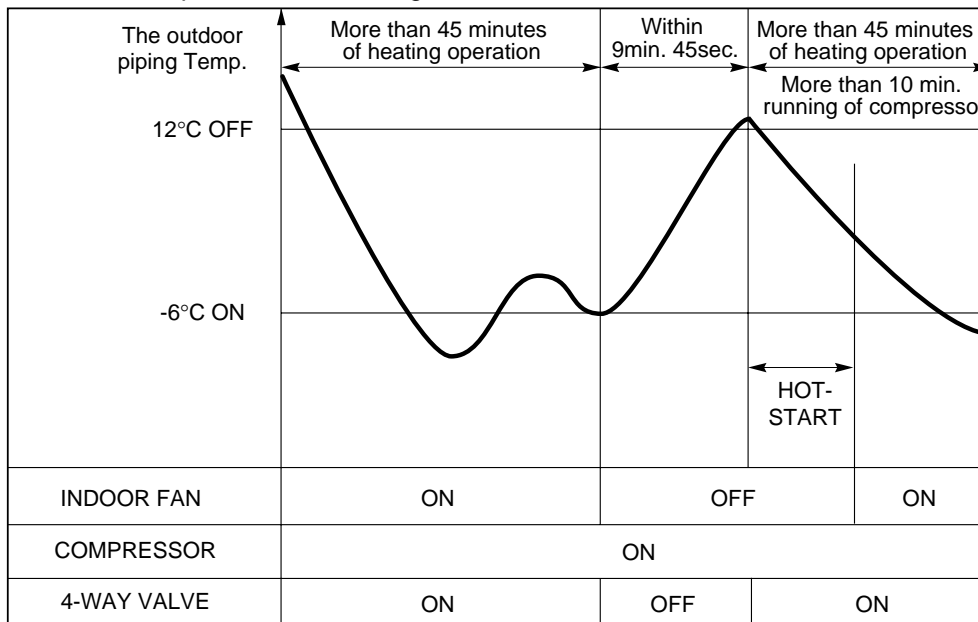

### ■ Defrost Control (New Type Defrost Control)

- While in heating mode operation in order to protect the evaporator pipe of the outdoor unit from freezing, reversed to cooling cycle to defrost the evaporator pipe of the outdoor unit.
- Defrost control is available 45 min. later since heating mode operation started, and it will not prolong over 10 min.
- Defrost control is carried out according to the following priority order while in heating mode operation.
  - 1st priority : Defrost control is carried out according to the indoor pipe temp 60 min. later since heating mode operation started.
  - 2nd priority : The temp differences between the indoor pipe temp and the intake air temp 25 min. later ( $\Delta T1$ ) and 45 min. later ( $\Delta T2$ ) since heating mode operation started are measured, then defrost control is carried out according to the difference ( $\Delta T = \Delta T1 - \Delta T2$ )
  - 3rd priority : Defrost control is carried out according to the temp difference ( $E = TE1 - TE2$ ) between the indoor pipe temperatures of 25 min later ( $TE1$ ) and 45 min later ( $TE2$ ) after heating mode operation started.
- When the indoor pipe temp is  $41^{\circ}\text{C}$  or above, defrost control is not carried out even if the condition is one of the defrost conditions above.
- While in defrost control, the compressor is on and the indoor fan, the outdoor fan, and the 4 way valve are off.

## 9. Self-diagnosis Function

- 'CHECK' will flash in the remote controller display when a problem occurs.
- Correct the 'FAULT MESSAGES' as shown in the table below before restarting operation.
- During the normal operation 'CHECK' won't be displayed in the remote controller.

Remote controller LCD	FAULT MESSAGES
CH 01	Indoor room temperature thermistor error
CH 02	Indoor piping thermistor error
CH 03	Indoor main body / Remote controller unit communication error
CH 04	Water level float switch error

# Installation of Indoor, Outdoor Unit

## 1. Selection of the best location

### 1) Indoor unit

- There should not be any heat source or steam near the unit.
- There should not be any obstacles to prevent the air circulation.
- A place where air circulation in the room will be good.
- A place where drainage can be easily obtained.
- A place where noise prevention is taken into consideration.
- Do not install the unit near the door way.
- Ensure the spaces indicated by arrows from the wall, ceiling, or other obstacles.
- The indoor unit must keep the maintenance space.

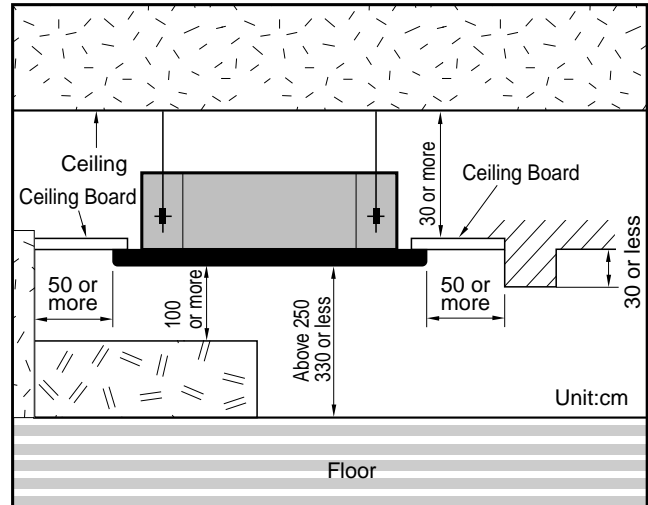

### 2) Outdoor unit

- If an awning is built over the unit to prevent direct sunlight or rain exposure, be careful that heat radiation from the condenser is not restricted.
- There should not be any animals or plants which could be affected by hot air discharged.
- Ensure the spaces indicated by arrows from the wall, ceiling, fence or other obstacles.

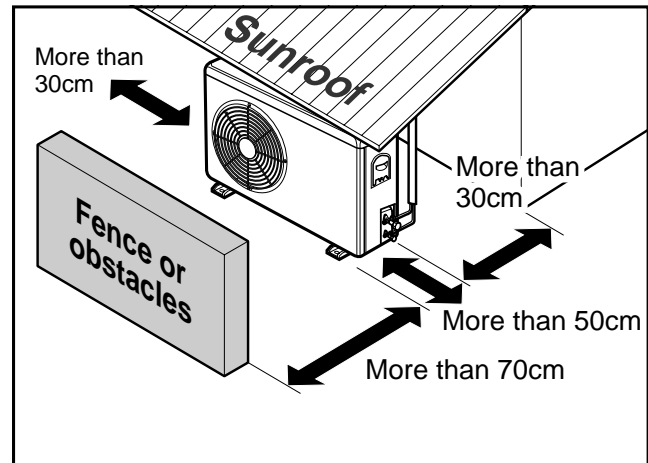

### 3) Piping length and the elevation

CAPACITY	Pipe Size		Length (A) (m)		Elevation (B) (m)		* Additional refrigerant (g/m)
	GAS	LIQUID	Rated	Max.	Rated	Max.	
24K Btu/h	1/4"	1/2"	7.5	30	5	15	30

- Rated performance for refrigerant line length of: 7.5m

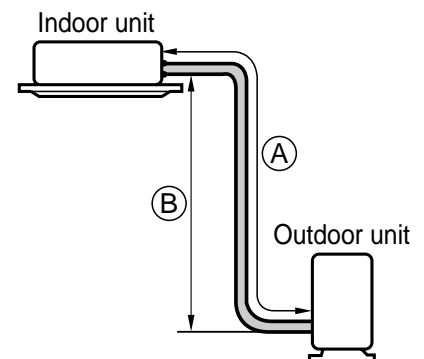

## 2. Ceiling opening dimensions and hanging bolt location

- The dimensions of the paper model for installing are the same as those of the ceiling opening dimensions.

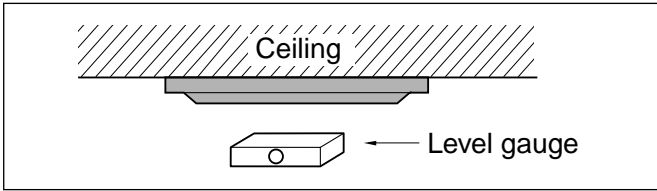

### CAUTION

- This air-conditioner uses a drain pump.
- Horizontally install the unit using a level gauge.
- During the installation, care should be taken not to damage electric wires.

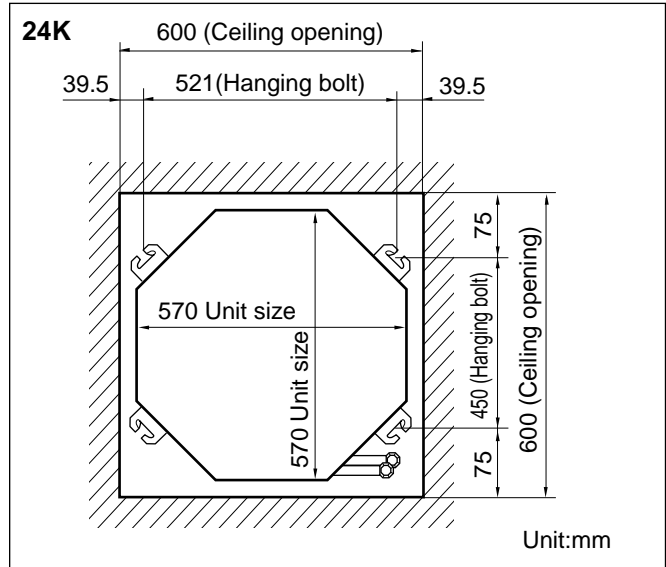
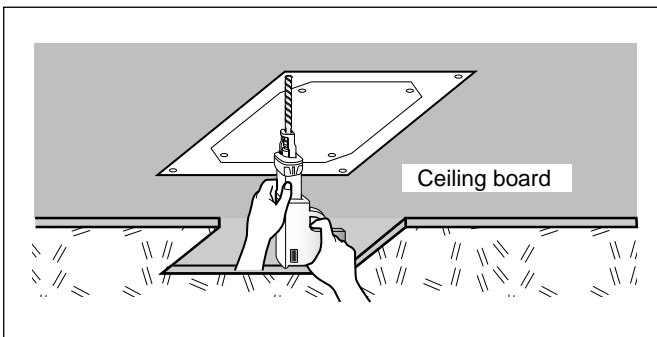

- Select and mark the position for fixing bolts and piping hole.
- Decide the position for fixing bolts slightly tilted to the drain direction after considering the direction of drain hose.
- Drill the hole for anchor bolt on the wall.

### NOTE:

- Thoroughly study the following installation locations:
  1. In such places as restaurants and kitchens, considerable amount of oil steam and flour adhere to the turbo fan, the fin of the heat exchanger and the drain pump, resulting in heat exchange reduction, spraying, dispersing of water drops, drain pump malfunction, etc.  
In these cases, take the following actions:
    - Make sure that the ventilation fan for smoke-collecting hood on a cooking table has sufficient capacity so that it draws oily steam which should not flow into the suction of the air conditioner.
    - Make enough distance from a cooking room to install the air conditioner in such a place where it may not suck in oily steam.

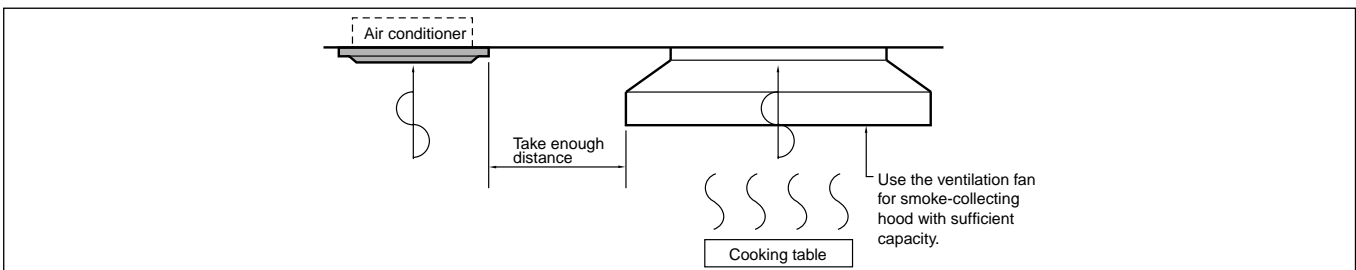

2. Avoid installing air conditioner in such circumstances where cutting oil mist or iron powder is in suspension in factories, etc.
3. Avoid places where inflammable gas is generated, flows in, is stored or vented.
4. Avoid places where sulfurous acid gas or corrosive gas is generated.
5. Avoid places near high frequency generators.

### 3. The Indoor Unit Installation

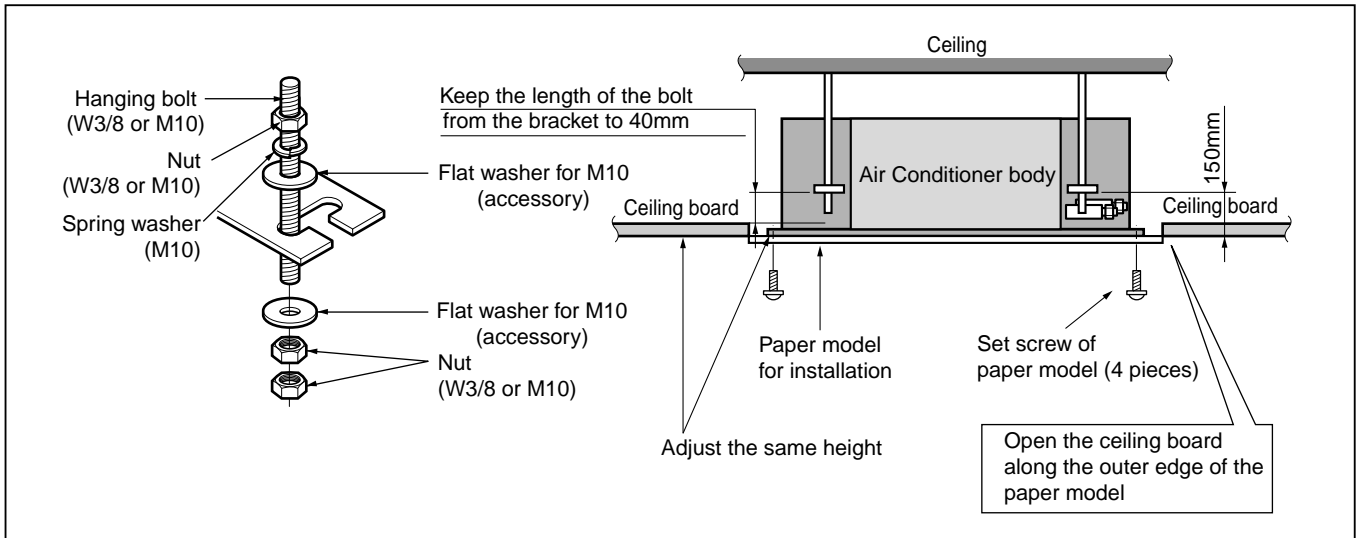

• The following parts is option.

- ① Hanging Bolt - W 3/8 or M10
- ② Nut - W 3/8 or M10
- ③ Spring Washer - M10
- ④ Plate Washer - M10

• Drill the piping hole on the wall slightly tilted to the outdoor side using a  $\varnothing 70$  hole-core drill.

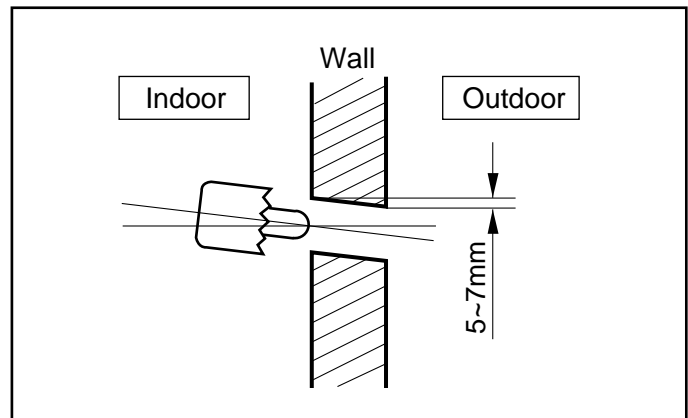

#### **CAUTION**

- Tighten the nut and bolt to prevent unit falling.

### 4. Remote Controller Installation

• Although the room temperature sensor is in the indoor unit, the remote controller should be installed in such places away from direct sunlight and high humidity.

#### Installation of the remote controller

- Select places that are not splashed with water.
- Select control position after receiving customer approval.
- The room temperature sensor is built in the indoor unit.
- This remote controller equipped with liquid crystal display. If this position is higher or lower, display is difficult to see. (The standard height is 1.2 ~ 1.5m high)

#### Routing of the remote controller cord

- Keep the remote controller cord away from the refrigerant piping and the drain piping.
- To protect the remote controller cord from electrical noise, place the cord at least 5cm away from other power cables (audio equipment, television set, etc.)
- If the remote controller cord is secured to the wall, provide a trap at the top of the cord to prevent water droplets from running.

## WIRED REMOTE CONTROL INSTALLATION

### DISASSEMBLING

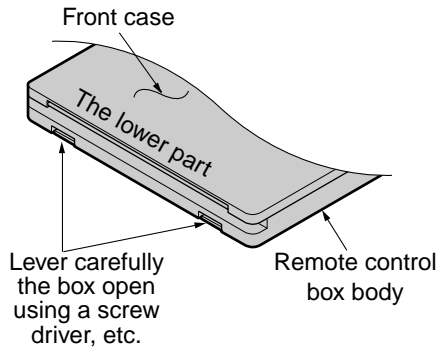

- Fix the under plate on the wall

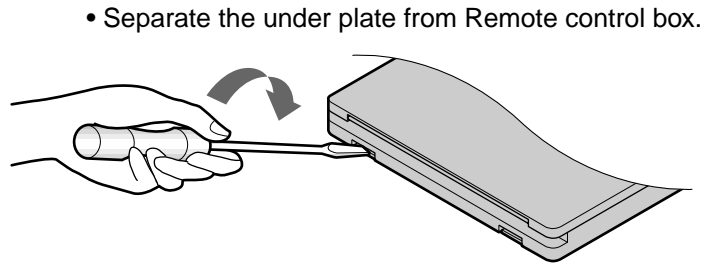
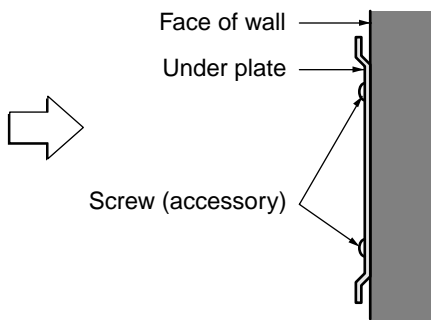

- Separate the under plate from Remote control box.

- Fix the cord clamps on the wall by  $\varnothing 3$  tapping screws (accessory).
- Fix the remote control cord.

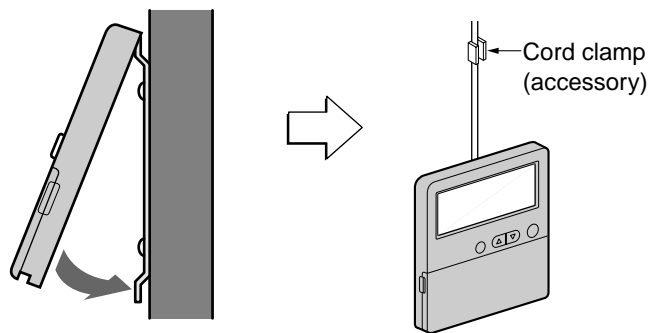

### ELECTRICAL WIRING

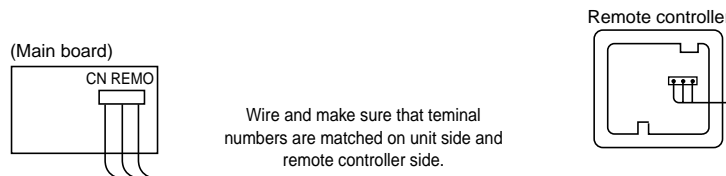

Wire and make sure that terminal numbers are matched on unit side and remote controller side.

The maximum length of the cord is 100m.  
If the length of the cord exceeds 50m,  
use a wire size greater than  $0.5\text{mm}^2$ .

## REMOTE CONTROL PREPARATION(OPTIONAL)

### HOW TO MOUNT ONTO A WALL

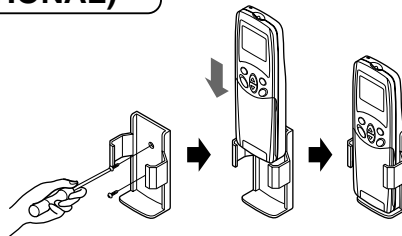

### HOW TO INSERT BATTERIES

- 1 Remove the battery cover from the remote controller.
  - Slide the cover according to the arrow direction.
- 2 Insert the two batteries.
  - Be sure that the (+) and (-) directions are correct.
  - Be sure that both batteries are new.
- 3 Re-attach the cover.
  - Slide it back into position.



- Do not use rechargeable batteries, such batteries differ from standard dry cells in shape, dimensions, and performance.
- Remove the batteries from the remote controller if the air conditioner is not going to be used for some long time.



## 5. Wiring Connection

- Open the control box cover and connect the Remote controller cord and Indoor power wires.

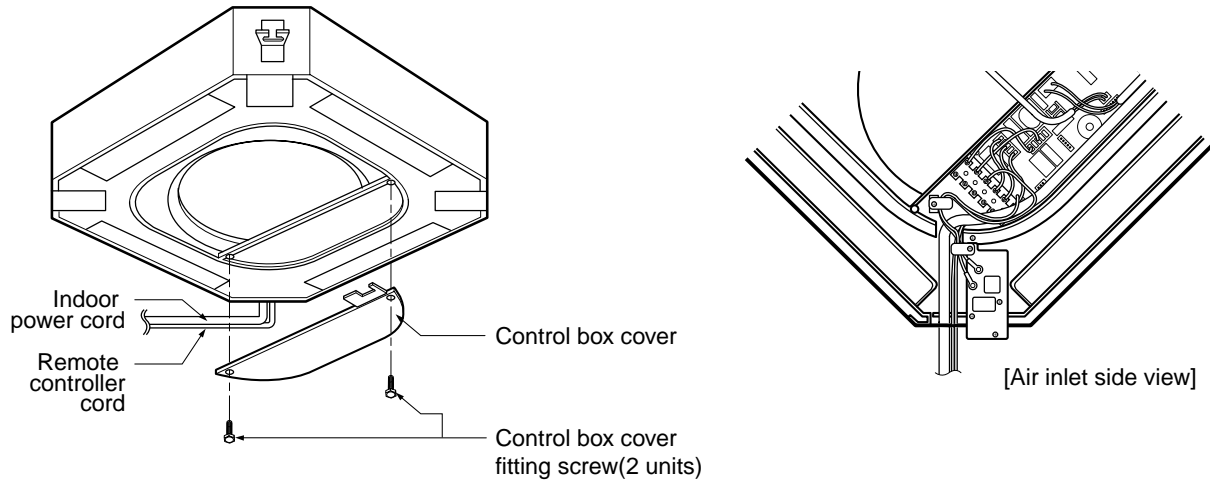

- 24K, 1 Phase Cooling Model

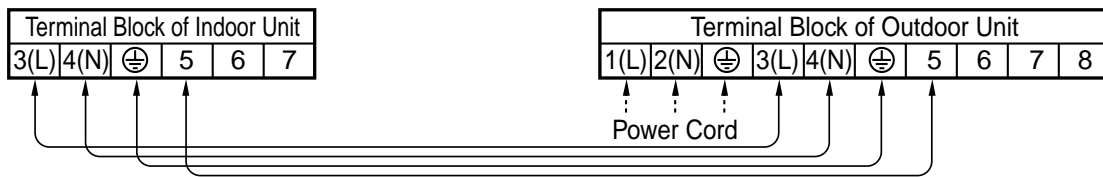

- 24K, 1 Phase Heat Pump

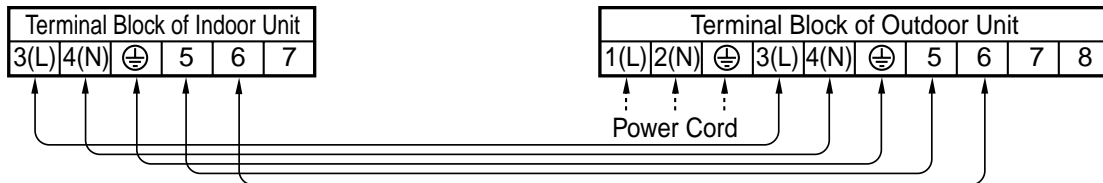

### CAUTION

The power cord connected to the outdoor unit should be complied with the following specifications (Rubber insulation, type H05RN-F approved by HAR or SAA).

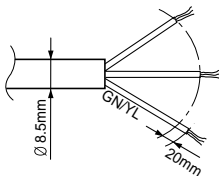

**NORMAL  
CROSS-SECTIONAL  
AREA 2.5mm<sup>2</sup> (24K)**

The connecting cable connected to the indoor and outdoor unit should be complied with the following specifications (Rubber insulation, type H05RN-F approved by HAR or SAA).

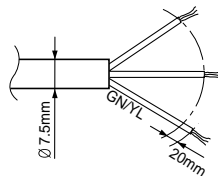

**NORMAL  
CROSS-SECTIONAL  
AREA 0.75mm<sup>2</sup>**

If the supply cord is damaged, it must be replaced by a special cord or assembly available from the manufacturer or its service agent.

### WARNING

Make sure that the screws of the terminal are free from looseness.

## ELECTRICAL WIRING

1. All wiring must comply with LOCAL REGULATIONS.
2. Select a power source that is capable of supplying the current required by the air conditioner.
3. Feed the power source to the unit via a distribution switch board designed for this purpose.
4. The terminal screws inside the control box may be loose due to vibration during transport.  
Check the screws for loose connection.  
(Running the air conditioner with loose connection can overload and damage electrical components.)
5. Always ground the air conditioner with a grounding wire and connector to meet the LOCAL REGULATION.

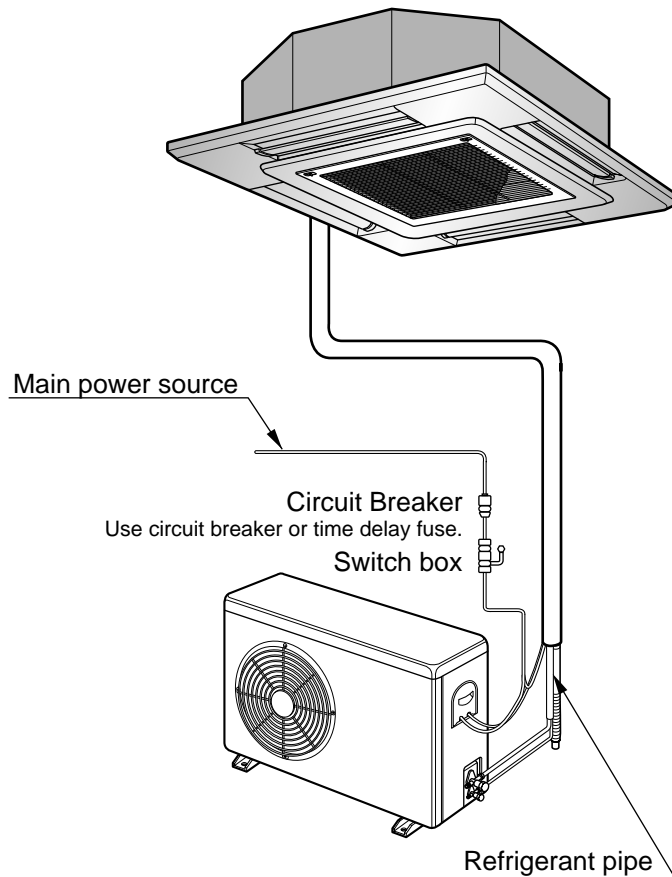

## CONNECTING THE CABLE TO OUTDOOR UNIT

1. Remove the Cover control from the unit by loosening a screw.  
Connect the wires to the terminals on the control board individually as following.
2. Secure the cable onto the control board with the holder (clammer).
3. Refix the cover control to the original position with the screw.
4. Use a recognized adequate circuit breaker between the power source and the unit. A disconnection device to adequately disconnect all supply lines must be fitted.

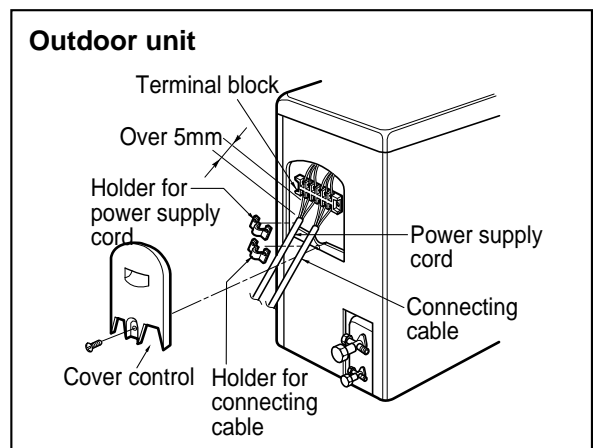

## 6. Connecting Pipes to the Indoor Unit

### • Preparation of Piping

Main cause of gas leakage is defect in flaring work. Carry out correct flaring work in the following procedure.

#### 1) Cut the pipes and the cable.

- Use the accessory piping kit or the pipes purchased locally.
- Measure the distance between the indoor and the outdoor unit.
- Cut the pipes a little longer than measured distance.
- Cut the cable 1.5m longer than the pipe length.

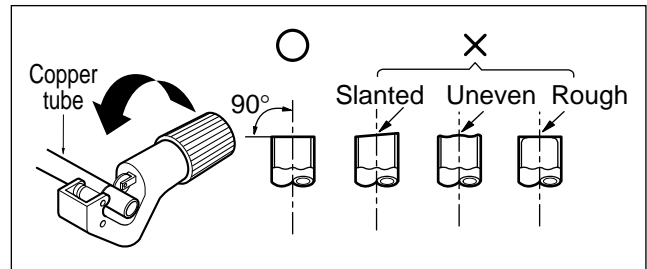

#### 2) Burrs removal

- Completely remove all burrs from the cut cross section of pipe/tube.
- Put the end of the copper tube/pipe to downward direction as you remove burrs in order to avoid to let burrs drop in the tubing.

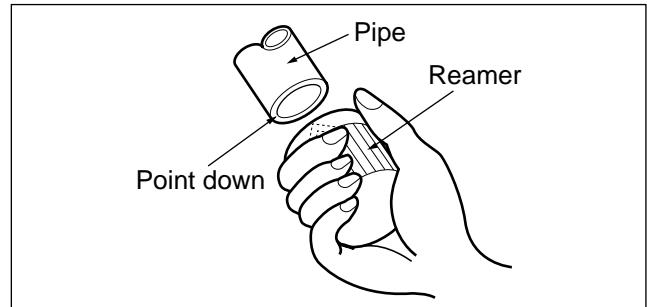

#### 3) Putting nut on

- Remove flare nuts attached to indoor and outdoor units, than put them on pipe/tube having completed burr removal.  
(Not possible to put them on after flaring work)

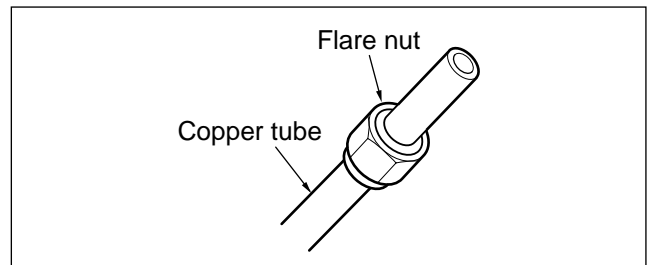

#### 4) Flaring work

- Carry out flaring work using flaring tool as shown below.

Outside diameter		A
mm	inch	mm
Ø6.35	3/8	0.5~0.8
Ø9.52	3/8	0.5~0.8
Ø12.7	1/2	0.5~0.8
Ø15.88	5/8	0.8~1.0
Ø19.05	3/4	1.0~1.3

Firmly hold copper tube in a bar(or die) as indicated dimension in the table above.

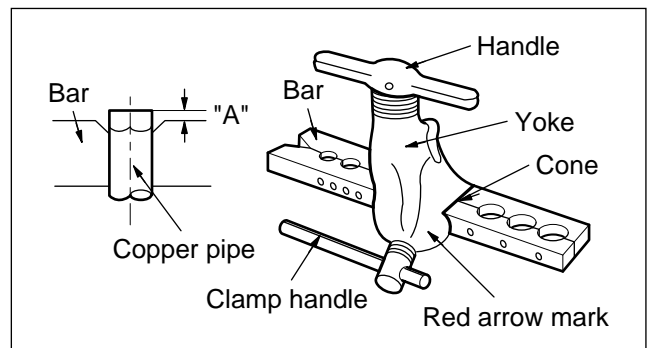

#### 5) Check

- Compare the flared work with figure below.
- If flare is noted to be defective, cut off the flared section and do flaring work again.

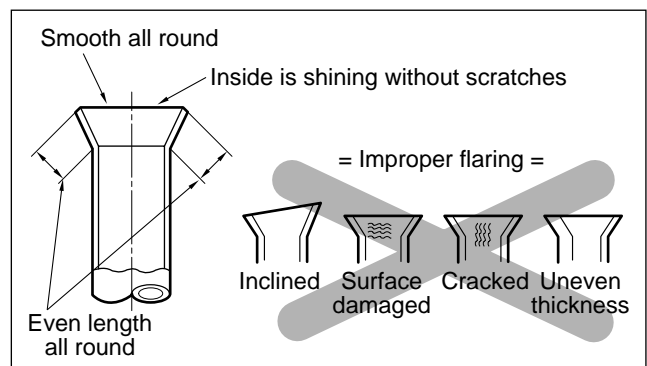

## Piping Connection

1. Form the piping according to its routing. Avoid bending and bending back the same piping point more than three times. (This will result in hardening the pipe.)
2. After deforming the piping, align centers of the union fitting of the indoor unit and the piping, and tighten them firmly with wrenches.
3. Connect pipe to the service valve or ball valve which is located below the outdoor unit.
4. After completing the piping connection, be sure to check if there is gas leakage in indoor and outdoor connection.

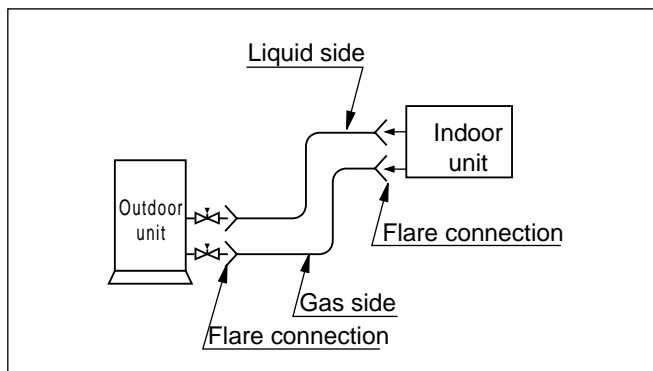

## Vacuum drying

After completing the piping connection, execute vacuum drying for the connecting piping and the indoor unit. The vacuum drying must be carried out using the service ports of both the liquid and gas side valves.

Model	Liquid side piping	Gas side piping
24K Btu/h	Ø 6.35mm	Ø12.7mm

## ⚠ CAUTION

Use two wrenches and tighten with regular torque.

Flare nut fastening torque	
Ø6.35mm	1.8kg·m
Ø9.52mm	4.0kg·m
Ø12.7mm	5.5kg·m
Ø15.88mm	6.6kg·m
Ø19.05mm	6.6kg·m

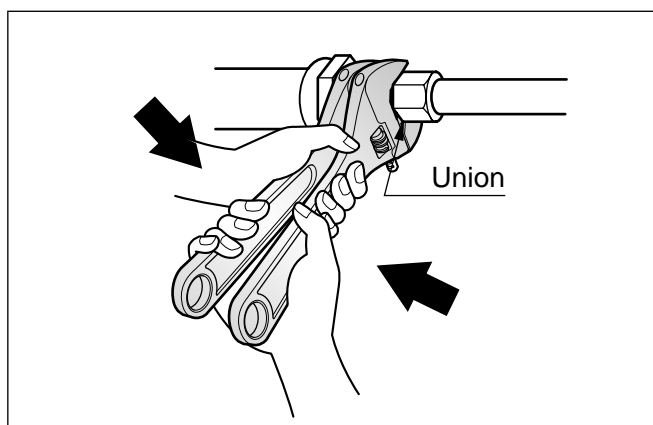

## 7. Installation of Decorative Panel

The decorative panel has its installation direction.

Before installing the decorative panel, always remove the paper template.

1. Temporarily fix two decorative panel fixing screws (hexagon M5 screw) on the unit body. (Tighten by amount 10mm in length.)  
The fixing screws (hexagon M5 screw) are included the indoor unit box.
2. Remove the air inlet grille from the decorative panel. (Remove the hook for the air inlet grille cord.)
3. Hook the decorative panel key hole (  ) on the screws fixed in step above, and slide the panel so that the screws reach the key hole edge.
4. Retighten completely two temporarily fixed screws and other two screws. (Total 4 screws)
5. Connect the louver motor connector and display connector.
6. After tightening these screws, install the air inlet grille (including the air filter).

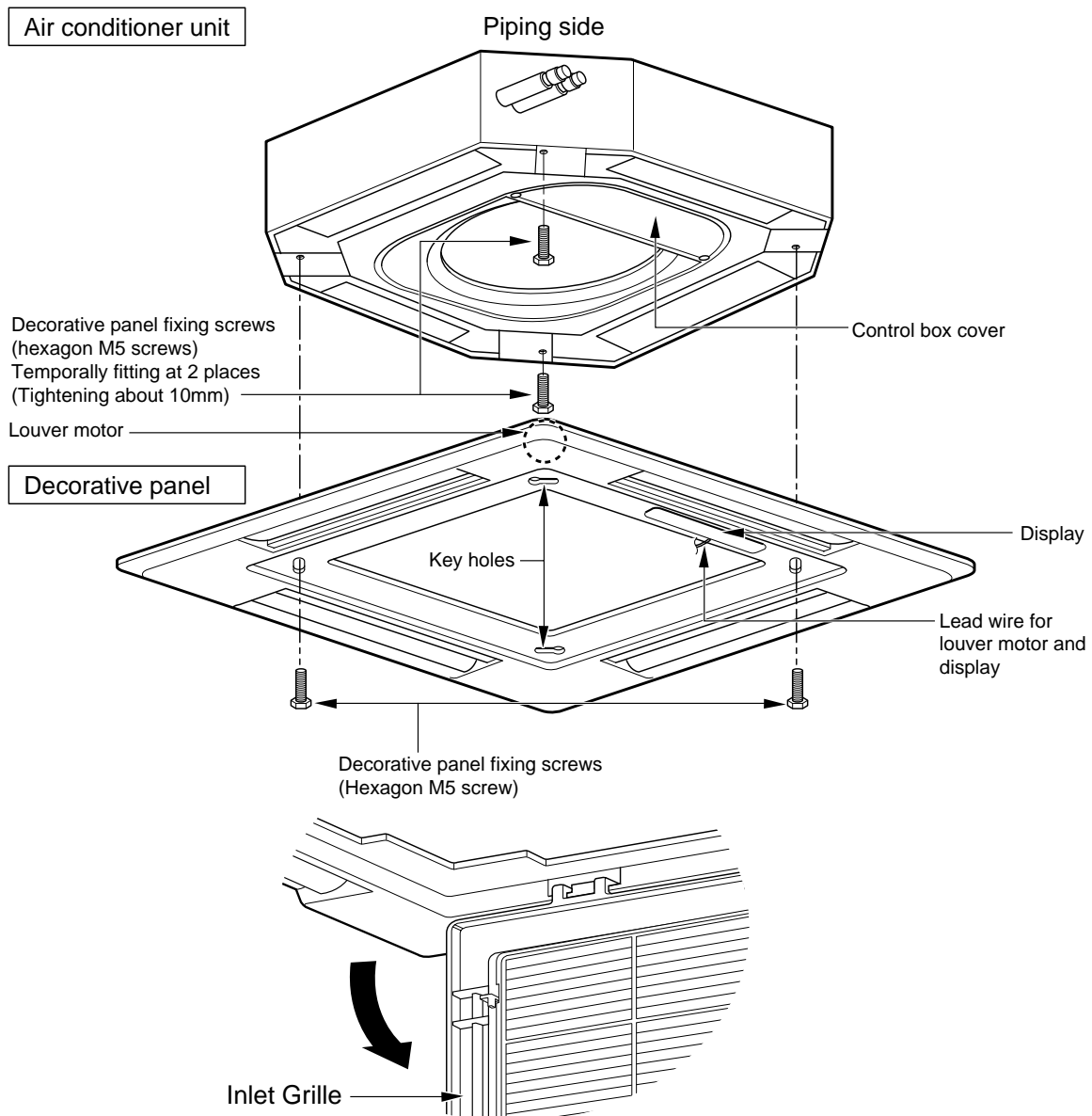

**CAUTION**

Install certainly the decorative panel.  
Cool air leakage causes sweating. ⇨ Water drops fall.

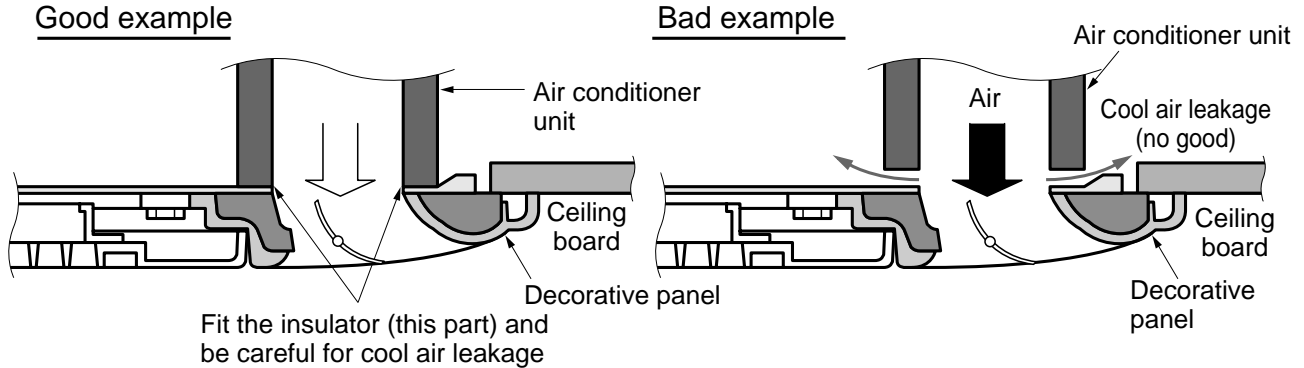

### 8. Indoor Unit Drain Piping

- Drain piping must have down-slope (1/50 to 1/100): be sure not to provide up-and-down slope to prevent reversal flow.
- During drain piping connection, be careful not to exert extra force on the drain port on the indoor unit.
- The outside diameter of the drain connection on the indoor unit is 32mm.

Piping material: Polyvinyl chloride pipe VP-25 and pipe fittings

- Be sure to execute heat insulation on the drain piping.

Heat insulation material: Polyethylene foam with thickness more than 8 mm.

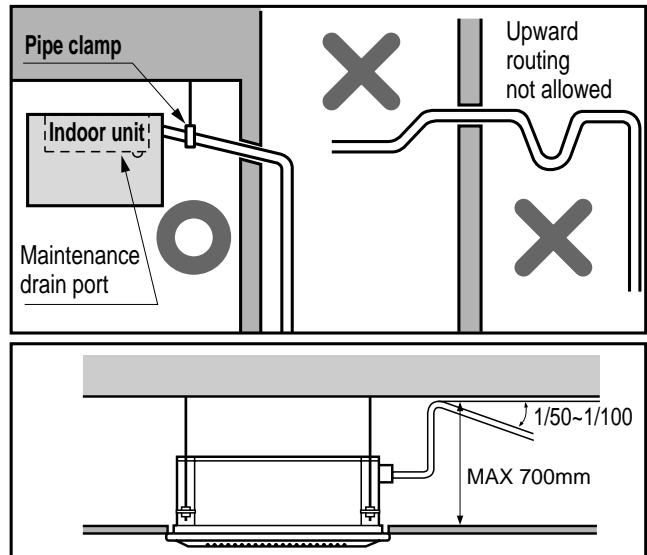

### Drain test

The air conditioner uses a drain pump to drain water.  
Use the following procedure to test the drain pump operation:

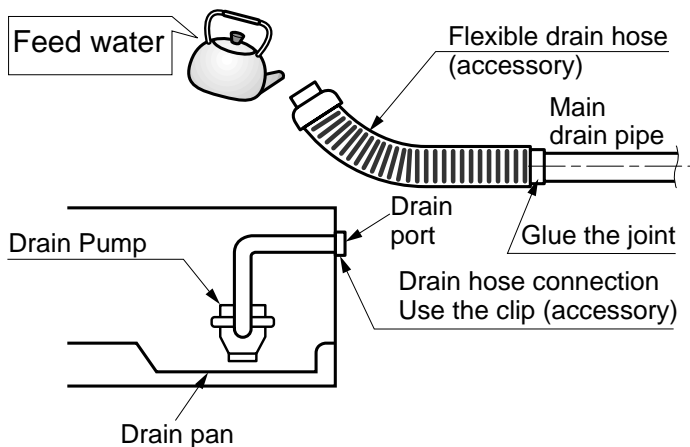

- Connect the main drain pipe to the exterior and leave it provisionally until the test comes to an end.
- Feed water to the flexible drain hose and check the piping for leakage.
- Be sure to check the drain pump for normal operating and noise when electrical wiring is complete.
- When the test is complete, connect the flexible drain hose to the drain port on the indoor unit.

## HEAT INSULATION

1. Use the heat insulation material for the refrigerant piping which has an excellent heat-resistance (over 120°C).

2. Precautions in high humidity circumstance:

This air conditioner has been tested according to the "KS Standard Conditions with Mist" and confirmed that there is not any default. However, if it is operated for a long time in high humid atmosphere (dew point temperature: more than 23°C), water drops are liable to fall. In this case, add heat insulation material according to the following procedure:

- Heat insulation material to be prepared... Adiabatic glass wool with thickness 10 to 20mm.
- Stick glass wool on all air conditioners that are located in ceiling atmosphere.
- In addition to the normal heat insulation (thickness: more than 8mm) for refrigerant piping (gas piping: thick piping) and drain piping, add further 10mm to 30mm thickness material.

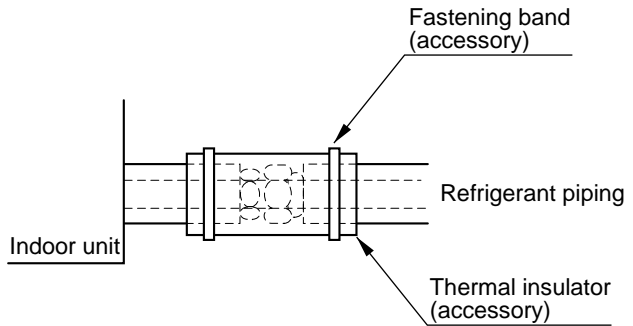

## FORM THE PIPINGS

1. Wrap the connecting portion of indoor unit with the Insulation material and secure it with two Plastic Bands. (for the right pipings)

- If you want to connect an additional drain hose, the end of the drain-outlet should keep distance from the ground. (Do not dip it into water, and fix it on the wall to avoid swinging in the wind.)

In case of the Outdoor unit being installed below position of the Indoor unit.

2. Tape the Pipings, drain hose and Connecting Cable from bottom to top.

3. Form the pipings gathered by taping along the exterior wall and fix it onto the wall by saddle or equivalent.

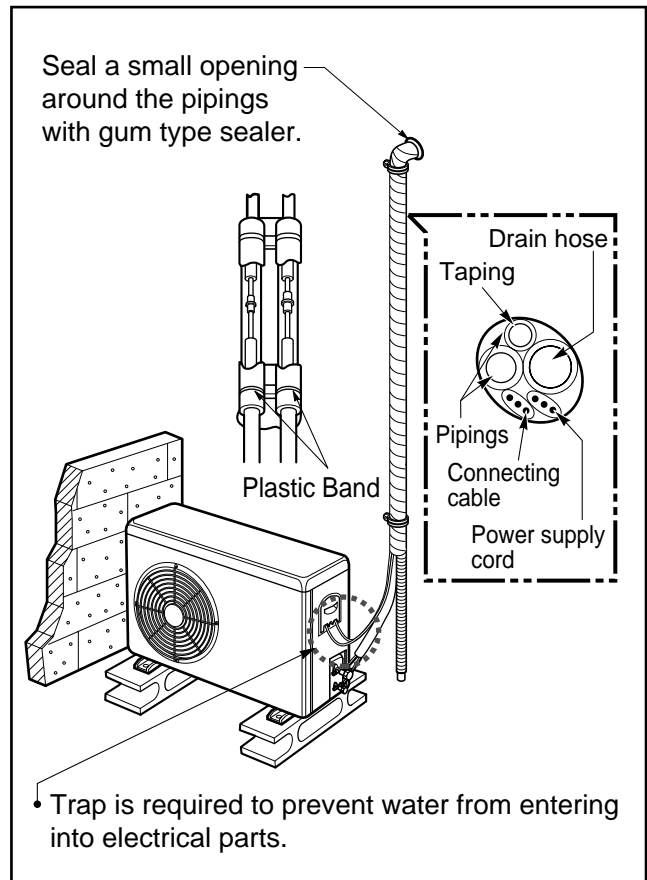

In case of the Outdoor Unit being installed above position of the Indoor Unit.

2. Tape the Pipings and Connecting cable from bottom to top.
3. Form the pipings gathered by taping along the exterior wall, and make the trap prevent water from entering into the room.
4. Fix the pipings onto the wall by saddle or equivalent.

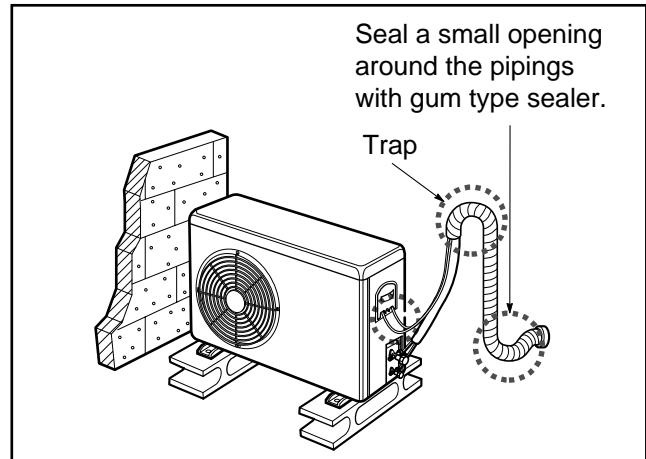

## Test running

### 1) PRECAUTIONS IN TEST RUN

- The initial power supply must provide at least 90% of the rated voltage. Otherwise, the air conditioner should not be operated.

#### Caution

- ① For test run, carry out the cooling operation firstly even during heating season. If heating operation is carried out firstly, it leads to the trouble of compressor. Then attention must be paid.
- ② Carry out the test run more than 5 minutes without fail.  
(Test run will be cancelled 18 minutes later automatically)

- The test run is started by pressing the room temperature checking button and down timer button for 3 seconds at the same time.
- To cancel the test run, press any button.

### CHECK THE FOLLOWING ITEMS WHEN INSTALLATION IS COMPLETE

- After completing work, be sure to measure and record trial run properties, and store measured data, etc.
- Measuring items are room temperature, outside temperature, suction temperature, blow out temperature, wind velocity, wind volume, voltage, current, presence of abnormal vibration and noise, operating pressure, piping temperature, compressive pressure.
- As to the structure and appearance, check following items.

- Is the circulation of air adequate?
- Is the draining smooth?
- Is the heat insulation complete (refrigerant and drain piping)?
- Is there any leakage of refrigerant?

- Is the remote controller switch operated?
- Is there any faulty wiring?
- Are not terminal screws loosened?

M4.....118N.cm{12kgf.cm} M5.....196N.cm{20kgf.cm}  
M6.....245N.cm{25kgf.cm} M8.....588N.cm{60kgf.cm}



## 2) Connection of power supply

1. Connect the power supply cord to the independent power supply.
  - Circuit breaker is required.
2. Operate the unit for fifteen minutes or more.

## 3) Evaluation of the performance

1. Measure the temperature of the intake and discharge air.
2. Ensure the difference between the intake temperature and the discharge one is more than 8°C (Cooling) or reversely (Heating).

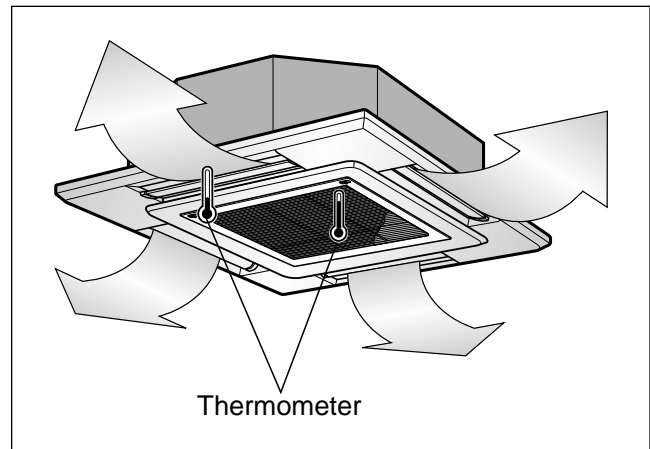

### CAUTION

After the confirmation of the above conditions, prepare the wiring as follows:

- 1) **Never fail to have an individual power specialized for the air conditioner. As for the method of wiring, be guided by the circuit diagram pasted on the inside of control box cover.**
- 2) **Provide a circuit breaker switch between power source and the unit.**
- 3) **The screw which fasten the wiring in the casing of electrical fittings are liable to come loose from vibrations to which the unit is subjected during the course of transportation. Check them and make sure that they are all tightly fastened. (If they are loose, it could give rise to burn-out of the wires.)**
- 4) **Specification of power source**
- 5) **Confirm that electrical capacity is sufficient.**
- 6) **Be sure that the starting voltage is maintained at more than 90 percent of the rated voltage marked on the name plate.**
- 7) **Confirm that the cable thickness is as specified in the power sources specification. (Particularly note the relation between cable length and thickness.)**
- 8) **Never fail to equip a leakage breaker where it is wet or moist.**
- 9) **The following troubles would be caused by voltage drop-down.**
  - Vibration of a magnetic switch, damage on the contact point there of, fuse breaking, disturbance to the normal function of a overload protection device.
  - Proper starting power is not given to the compressor.

### HAND OVER

Teach the customer the operation and maintenance procedures, using the operation manual (air filter cleaning, temperature control, etc.).

# Optional Operation

## 1) Two Thermistor System

- (1) Open the rear cover of the wired remote-controller to set the mode.
- (2) Select one of three selectable modes as follows.
  - Position 1:  
The room temperature is controlled by the thermistor of the main body.
  - Position 2:  
The room temperature is controlled by the thermistor of the wired remote-controller, control the temperature according to the position of wired remote-controller.
  - Position 3:  
The room temperature is controlled by lower temperature between the temperature of main body and of remote-controller sensor.
- (3) Move the slide switch to set position.

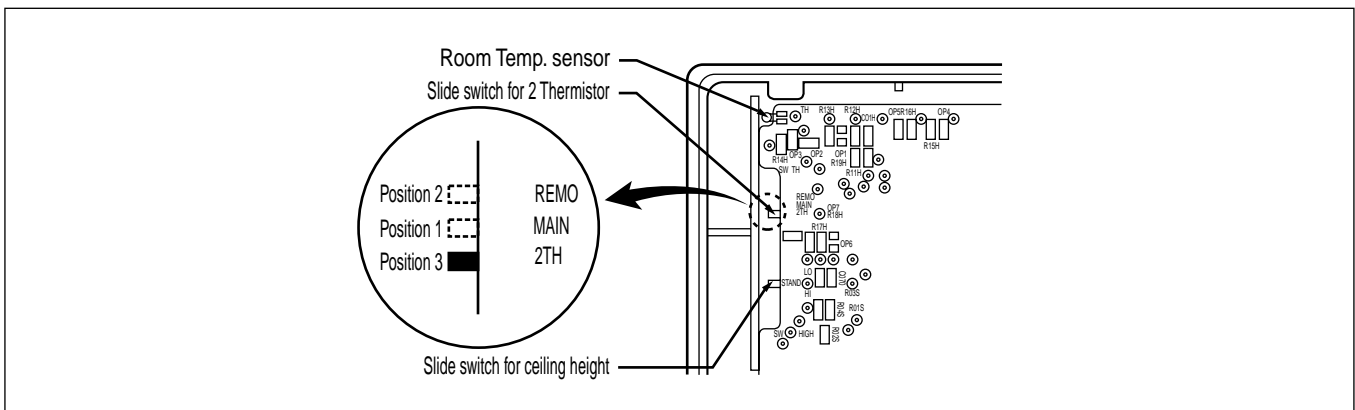

- (4) Close the rear cover and check if it works normally.

### **CAUTION**

- Select the position after counselling with a customer.
- In case of cooling mode, room temperature is controlled by the main body sensor.
- To control the room temperature by a wired remote controller, install controller(room temp. sensor) to sense the temperature more accurately.
- Manufactured in the position 3.

## 2) Adjusting air volume to the height of ceiling

You can choose the RPM(or air volume) of indoor motor according to the height of ceiling to supply the comfortable atmosphere to consumers.

### Procedure

1. Choose the selectable position in the table after measuring the height of ceiling.

Ceiling height	Mode of slide switch	Change of air volume	Remark
more than 3.3m	High Ceiling	Increasing	Manufactured in standard mode
2.7~3.3m	Standard	-	
less than 2.7m	Low Ceiling	Decreasing	

2. In the case of changing the height as "high" or "low", open the rear cover of the wired remote-controller.

3. Move the slide switch to the set position.

4. Close the rear cover and check if it works normally.

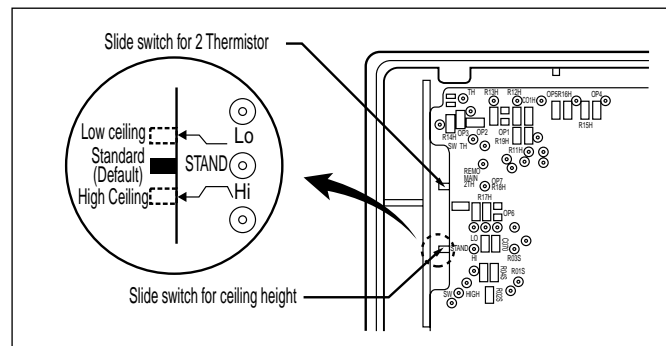

## 3) Group Control(Optional Wiring)

- You can use a group control operation after connecting the brown and yellow wire of each air-conditioner.
- Remove the resistor "OP 7" in remote controller.
- It operates maximum 16 Units by only one Wired Remote Controller, and each Unit starts sequentially to prevent overcurrent.

### Wiring design

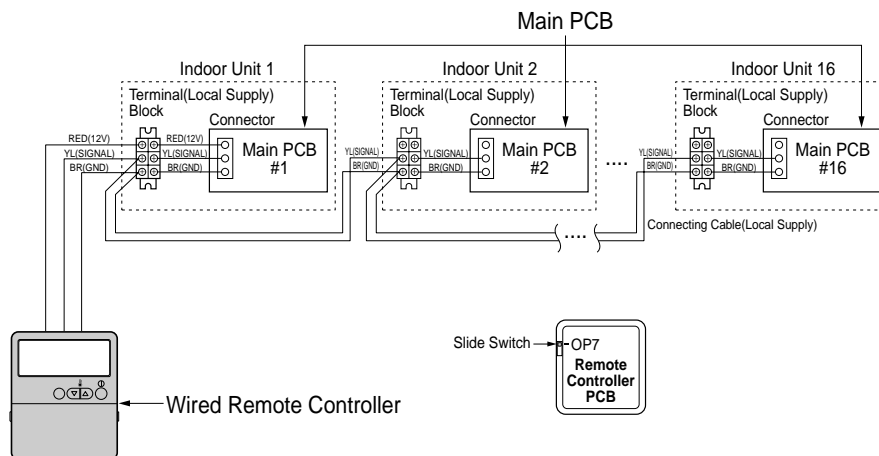

### Features

- Use Only One Wired Remote Controller with several air conditioners(max. 16 Units)
- Random starting to prevent overcurrent.

### CAUTION

- Be careful not to exchange the color of wires.
- The maximum length of connecting wire should be below 200m(25Ω) on connecting each units.
- Use a wire more than 0.5mm<sup>2</sup>

# 2-way Valve, 3-way Valve

## 1. Pumping down

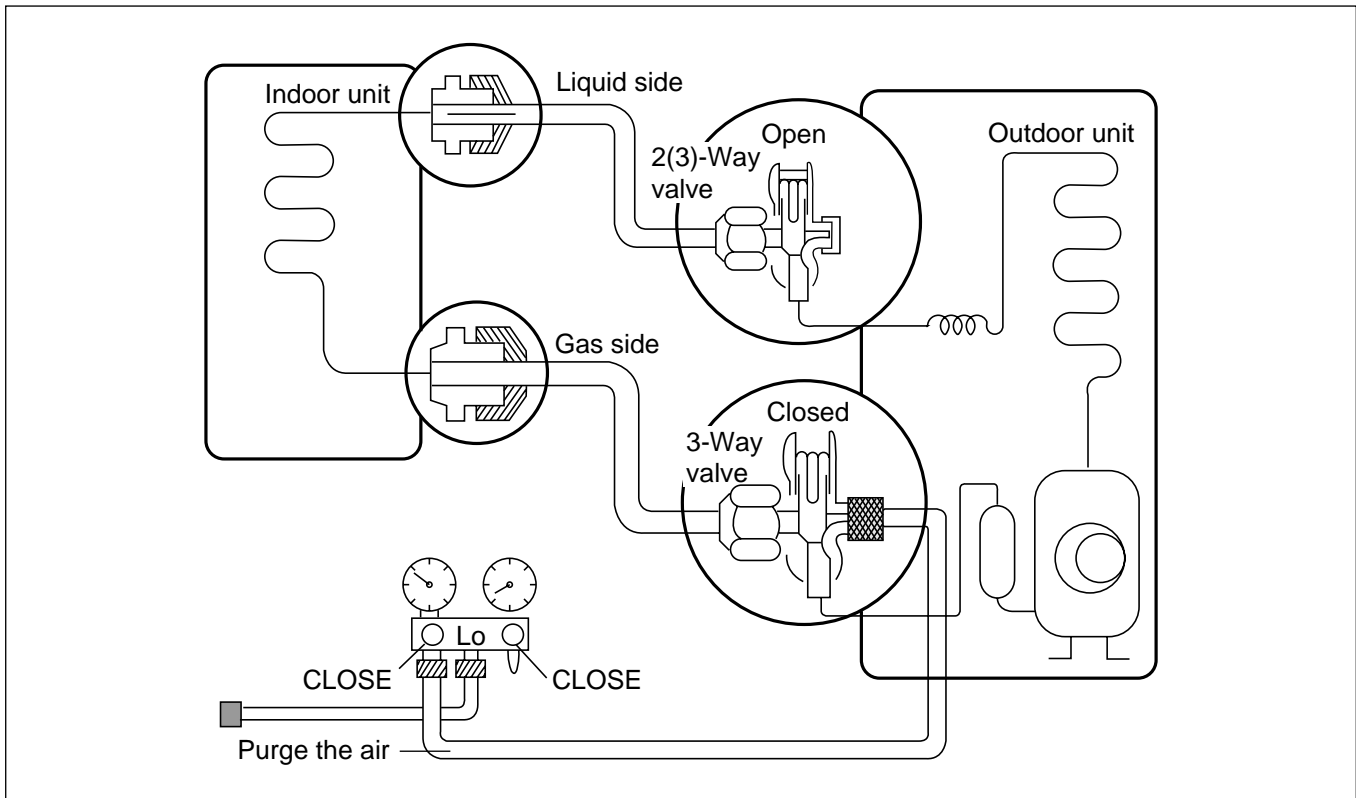

### • Procedure

- (1) Confirm that both liquid side and gas side valves are set to the open position.**
  - Remove the valve stem caps and confirm that the valve stems are in the raised position.
  - Be sure to use a hexagonal wrench to operate the valve stems.
- (2) Operate the unit for 10 to 15 minutes.**
- (3) Stop operation and wait for 3 minutes, then connect the charge set to the service port of the 3-way valve.**
  - Connect the charge hose to the service port.
- (4) Air purging of the charge hose.**
  - Open the low-pressure valve on the charge set slightly to air purge from the charge hose.
- (5) Set the liquid side valve to the closed position.**
- (6) Operate the air conditioner in cooling mode and stop it when the gauge indicates 1kg/cm<sup>2</sup>g.**
- (7) Immediately set the 3-way valve to the closed position.**
  - Do this quickly so that the gauge ends up indicating 3 to 5kg/cm<sup>2</sup>g.
- (8) Disconnect the charge set, and mount the 2-way and 3-way valve's stem nuts and the service port nut.**
  - Use torque wrench to tighten the service port nut to a torque of 1.8 kg.m.
  - Be sure to check for gas leakage.

## 1) Re-air purging (Re-installation)

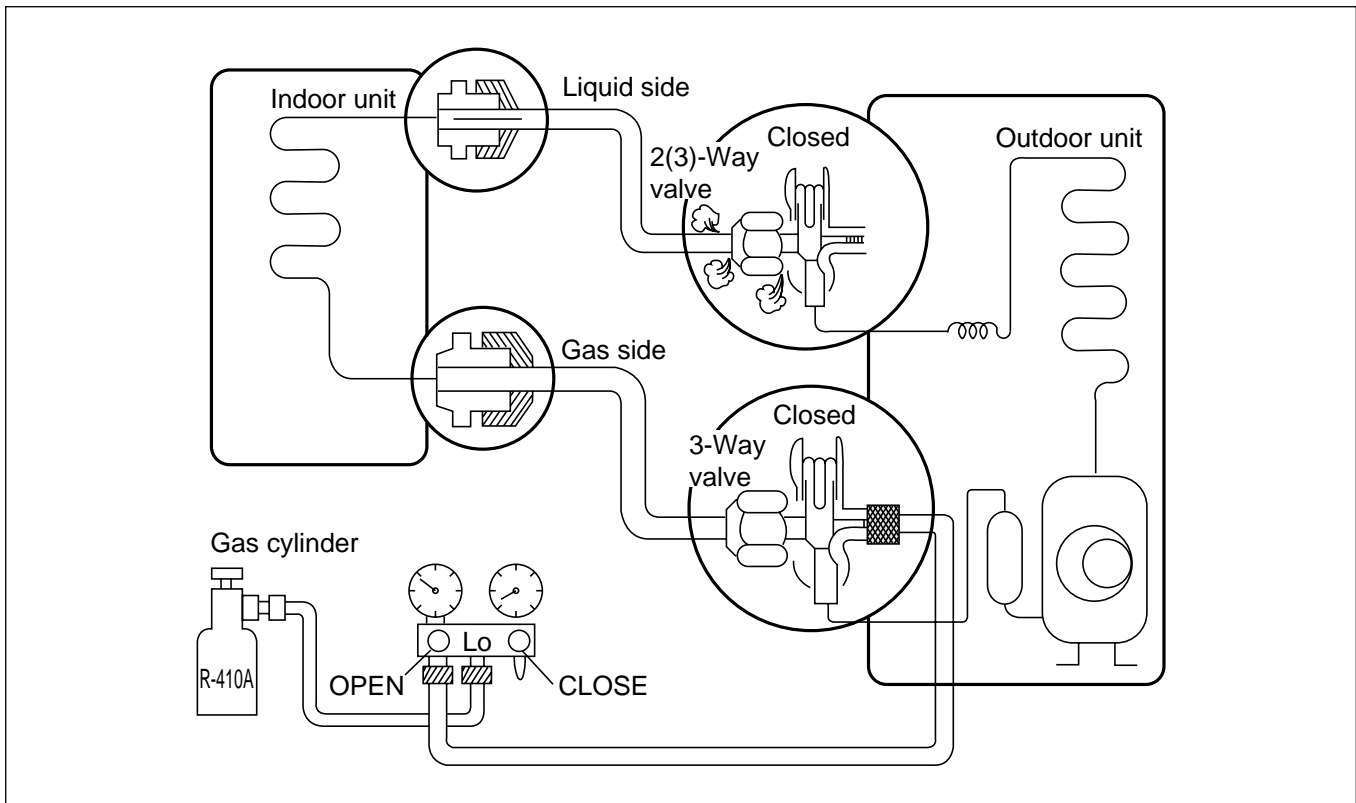

### • Procedure

- (1) **Confirm that both the liquid side valve and the gas side valve are set to the closed position.**
- (2) **Connect the charge set and a gas cylinder to the service port of the 3-way valve.**
  - Leave the valve on the gas cylinder closed.
- (3) **Air purging.**
  - Open the valves on the gas cylinder and the charge set. Purge the air by loosening the flare nut on the liquid side valve approximately 45° for 3 seconds then closing it for 1 minute; repeat 3 times.
  - After purging the air, use a torque wrench to tighten the flare nut on liquid side valve.
- (4) **Check for gas leakage.**
  - Check the flare connections for gas leakage.
- (5) **Discharge the refrigerant.**
  - Close the valve on the gas cylinder and discharge the refrigerant until the gauge indicates 3 to 5 kg/cm<sup>2</sup>g.
- (6) **Disconnect the charge set and the gas cylinder, and set the 2-way and 3-way valves to the open position.**
  - Be sure to use a hexagonal wrench to operate the valve stems.
- (7) **Mount the valve stem nuts and the service port nut.**
  - Use torque wrench to tighten the service port nut to a torque of 1.8 kg.m.
  - Be sure to check for gas leakage.

\* **CAUTION:**  
**Do not leak the gas in the air during Air Purging.**

## 2) Balance refrigerant of the 3-way valve

(Gas leakage)

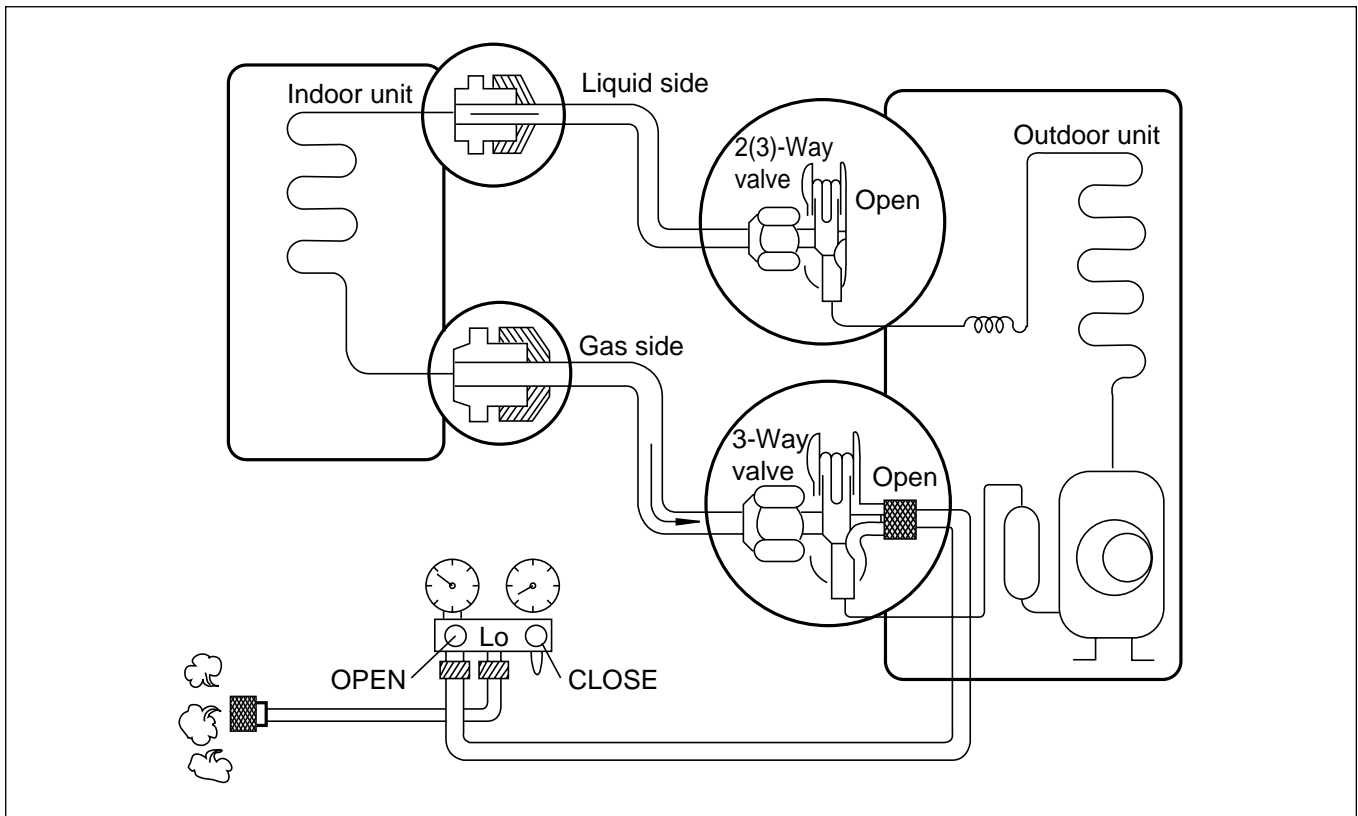

### • Procedure

- (1) Confirm that both the liquid side and gas side valves are set to the back seat.
- (2) Connect the charge set to the 3-way valve's port.
  - Leave the valve on the charge set closed.
  - Connect the charge hose to the service port.
- (3) Open the valve (Lo side) on the charge set and discharge the refrigerant until the gauge indicates **0 kg/cm<sup>2</sup>G**.
  - If there is no air in the refrigerant cycle (the pressure when the air conditioner is not running is higher than 1 kg/cm<sup>2</sup>G), discharge the refrigerant until the gauge indicates 0.5 to 1 kg/cm<sup>2</sup>G. If this is the case, it will not be necessary to apply a evacuation.
  - Discharge the refrigerant gradually; if it is discharged too suddenly, the refrigeration oil will also be discharged.

## 2. Evacuation

(All amount of refrigerant leaked)

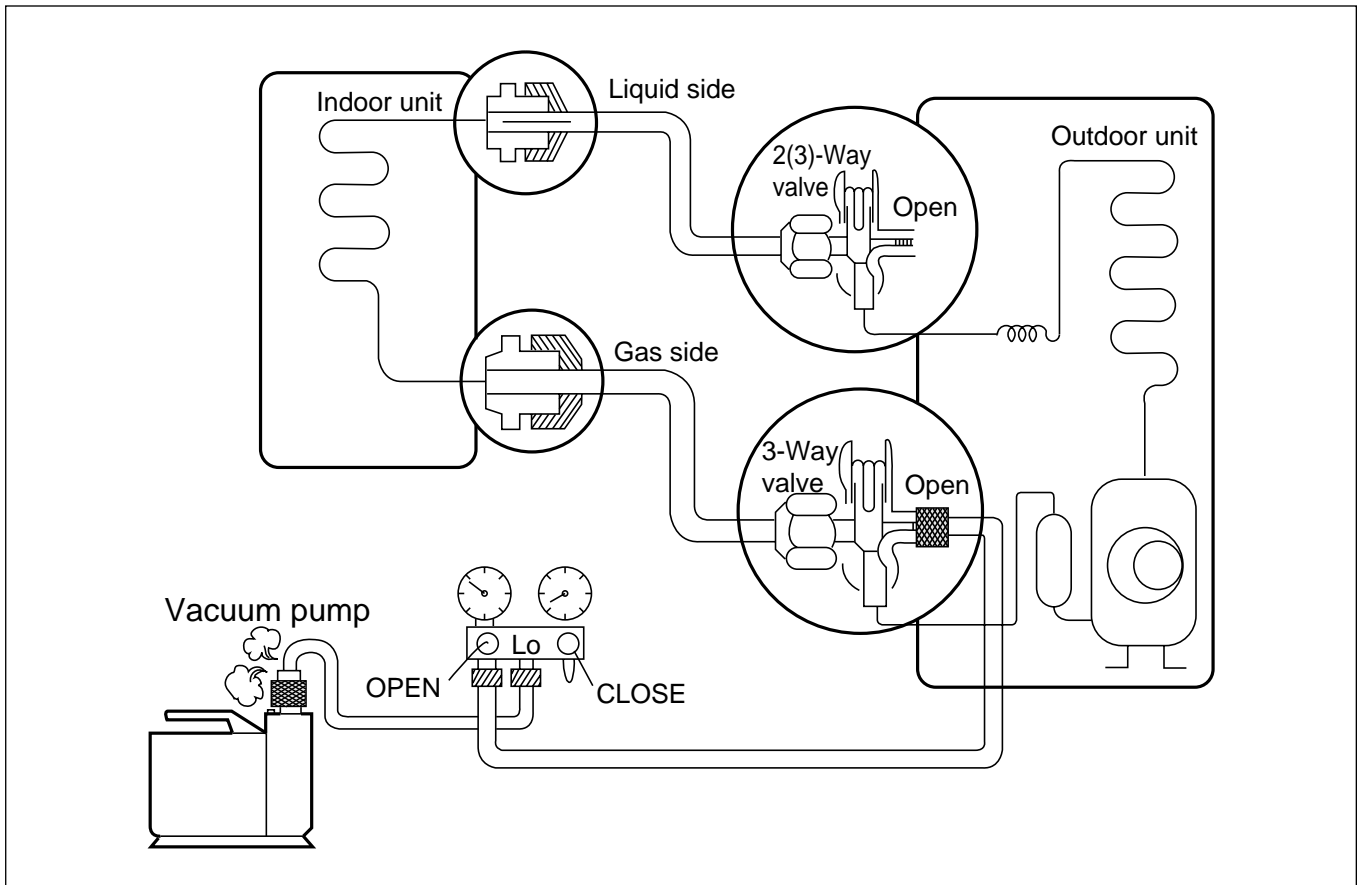

### • Procedure

- (1) Connect the vacuum pump to the center hose of charge set center hose
- (2) Evacuation for approximately one hour.
  - Confirm that the gauge needle has moved toward -76 cmHg (vacuum of 4 mmHg or less).
- (3) Close the valve (Lo side) on the charge set, turn off the vacuum pump, and confirm that the gauge needle does not move (approximately 5 minutes after turning off the vacuum pump).
- (4) Disconnect the charge hose from the vacuum pump.
  - Vacuum pump oil.  
If the vacuum pump oil becomes dirty or depleted, replenish as needed.

### 3. Gas Charging

(After Evacuation)

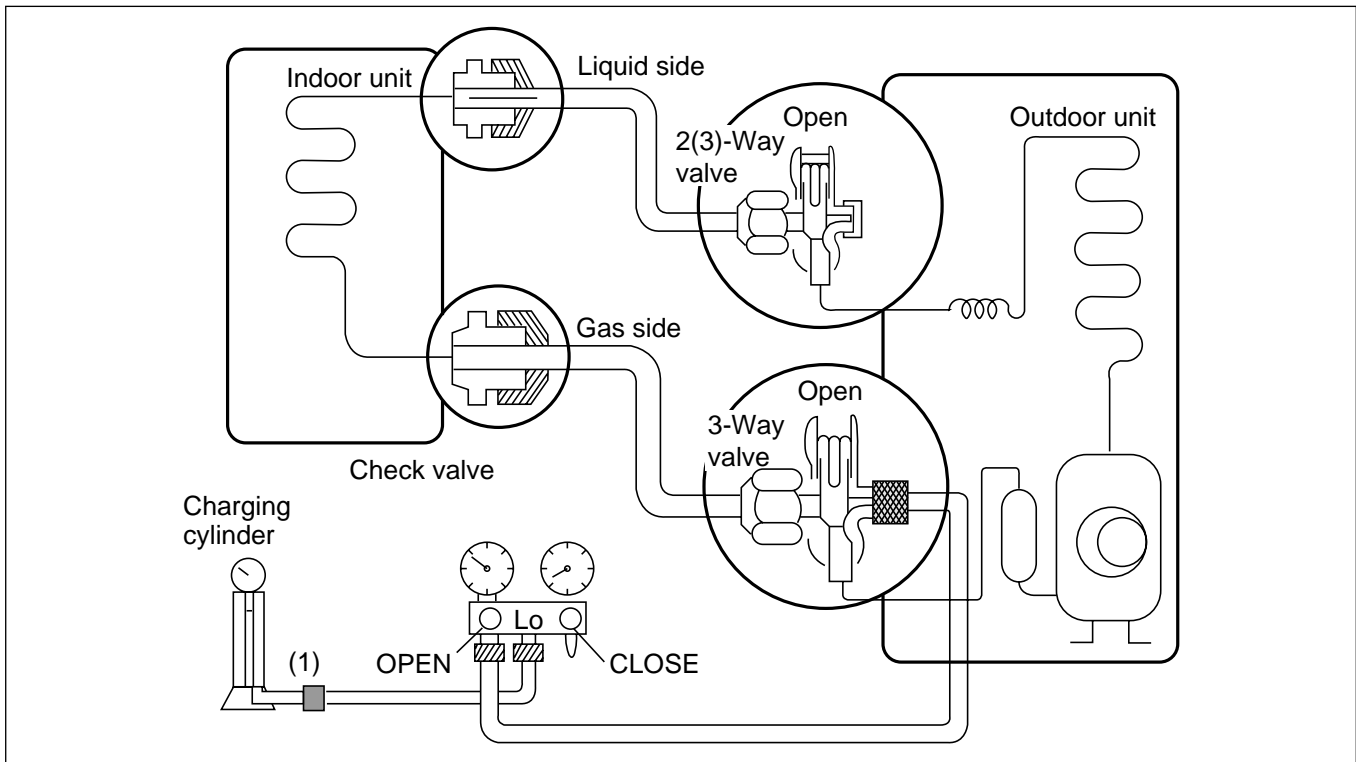

#### • Procedure

##### (1) Connect the charge hose to the charging cylinder.

- Connect the charge hose which you disconnected from the vacuum pump to the valve at the bottom of the cylinder.
- If you are using a gas cylinder, also use a scale and reverse the cylinder so that the system can be charged with liquid.

##### (2) Purge the air from the charge hose.

- Open the valve at the bottom of the cylinder and press the check valve on the charge set to purge the air. (Be careful of the liquid refrigerant). The procedure is the same if using a gas cylinder.

##### (3) Open the valve (Lo side on the charge set and charge the system with liquid refrigerant.

- If the system can not be charged with the specified amount of refrigerant, it can be charged with a little at a time (approximately 150g each time) while operating the air conditioner in the cooling cycle; however, one time is not sufficient, wait approximately 1 minute and then repeat the procedure (pumping down-pin).

This is different from previous procedures. Because you are charging with liquid refrigerant from the gas side, absolutely do not attempt to charge with larger amounts of liquid refrigerant while operating the air conditioner.

##### (4) Immediately disconnect the charge hose from the 3-way valve's service port.

- Stopping partway will allow the gas to be discharged.
- If the system has been charged with liquid refrigerant while operating the air conditioner turn off the air conditioner before disconnecting the hose.

##### (5) Mount the valve stem nuts and the service port nut.

- Use torque wrench to tighten the service port nut to a torque of 1.8 kg.m.
- Be sure to check for gas leakage.



# Cycle Troubleshooting Guide

## Trouble analysis

1. Check temperature difference between intake and discharge air and operating current.

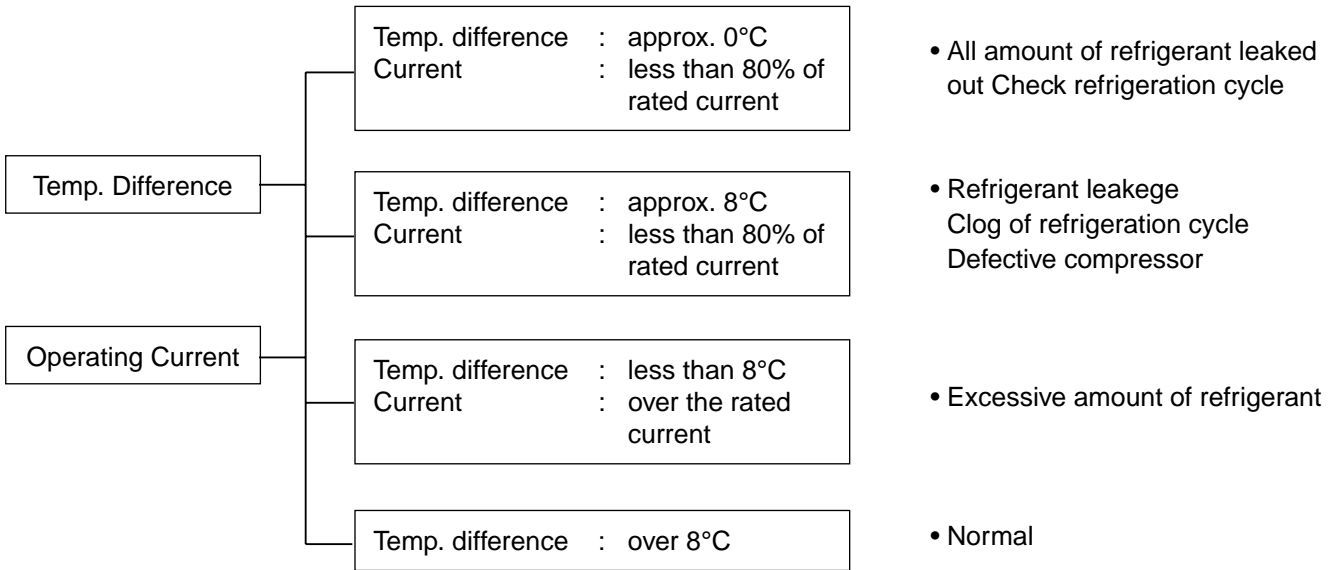

**Notice :**

Temperature difference between intake and discharge air depends on room air humidity. When the room air humidity is relatively higher, temperature difference is smaller. When the room air humidity is relatively lower temperature difference is larger.

2. Check temperature and pressure of refrigeration cycle.

Suction pressure (Compared with the normal value)	Temperature (Compared with the normal value)	Cause of Trouble	Description
Higher	High	Defective compressor Defective 4-way reverse valve	Current is low
	Normal	Excessive amount of refrigerant	High pressure does not quickly rise at the beginning of operation
Lower	Higher	Insufficient amount of refrigerant (Leakage) Clogging	Current is low Current is low

**Notice :**

1. The suction pressure is usually 4.5~6.0 kg/cm<sup>2</sup>G at normal condition.
2. The temperature can be measured by attaching the thermometer to the low pressure tubing and wrap it with putty.

# Electronic Parts Troubleshooting Guide

---

**Possible Trouble 1** : The unit does not operate.

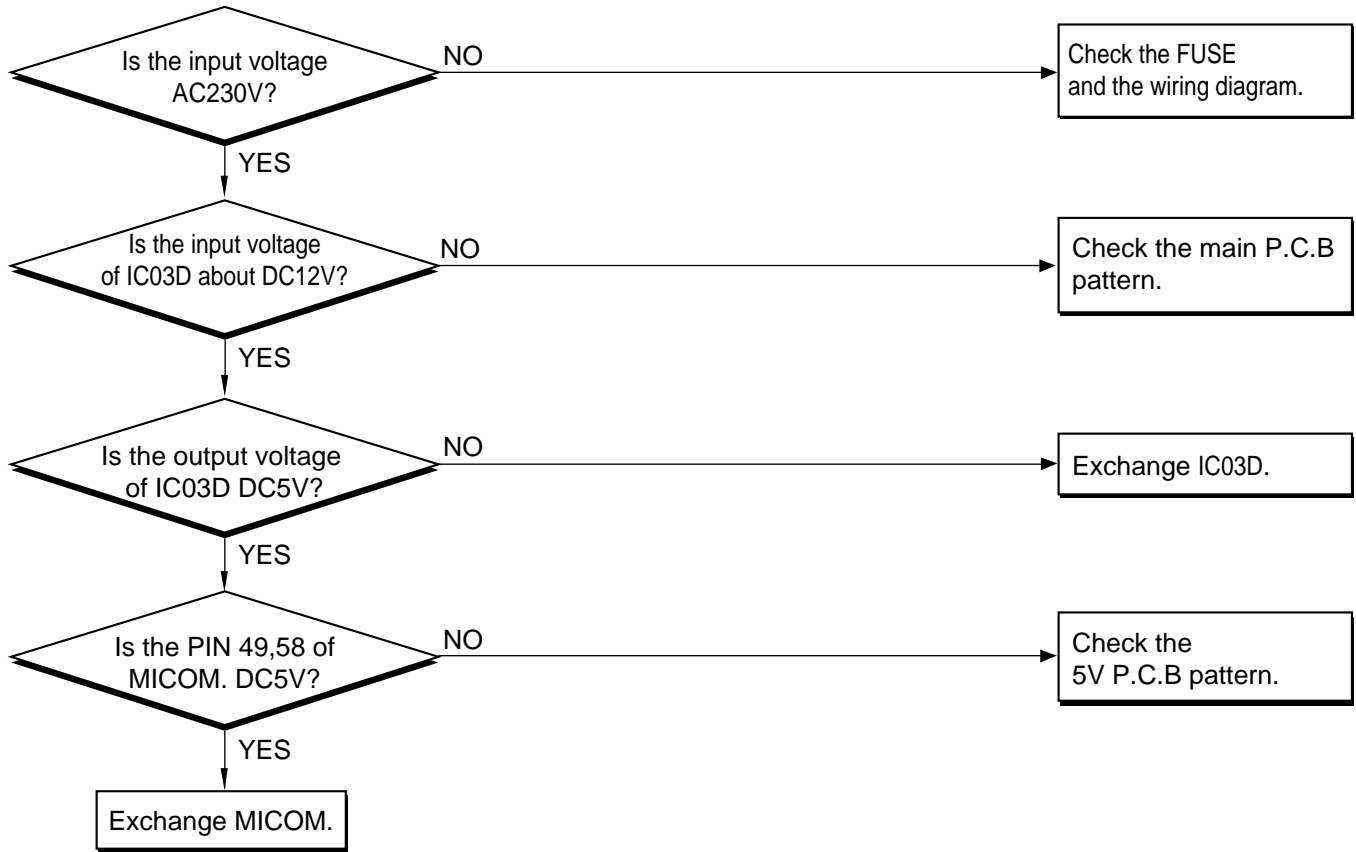

**Possible Trouble 2** : The indoor fan does not operate.

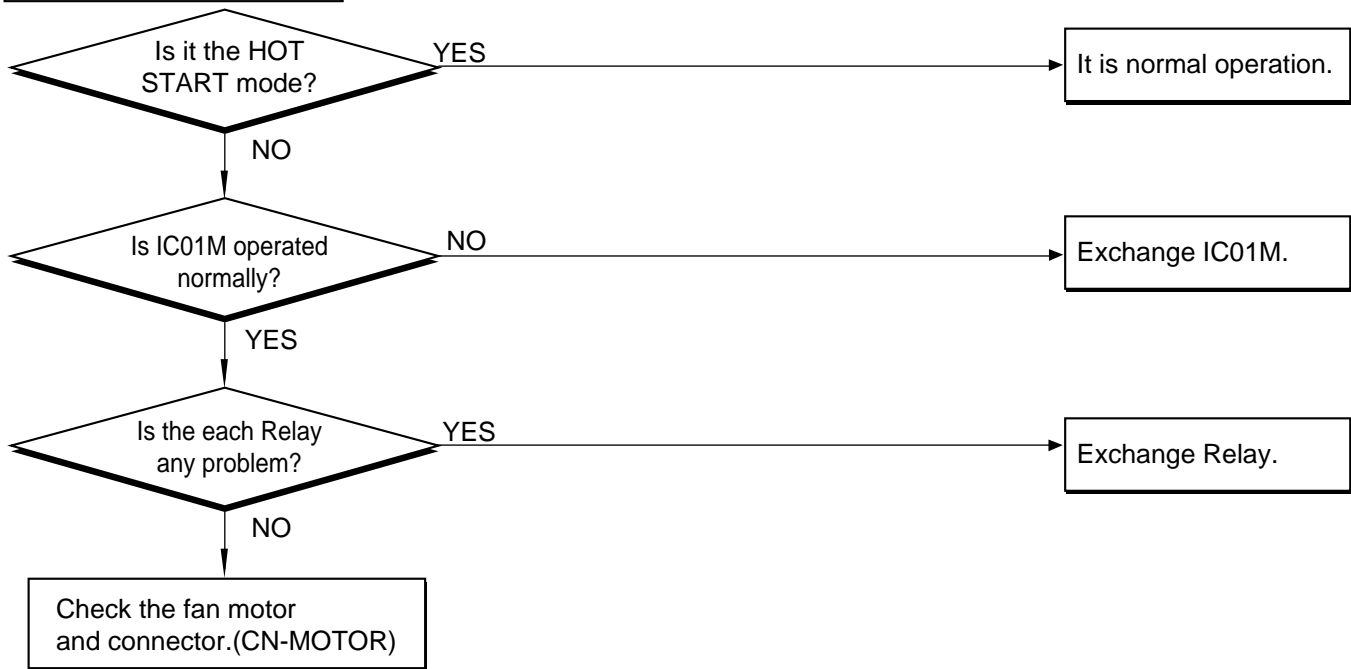

**Possible Trouble 3** : Ineffective Heating

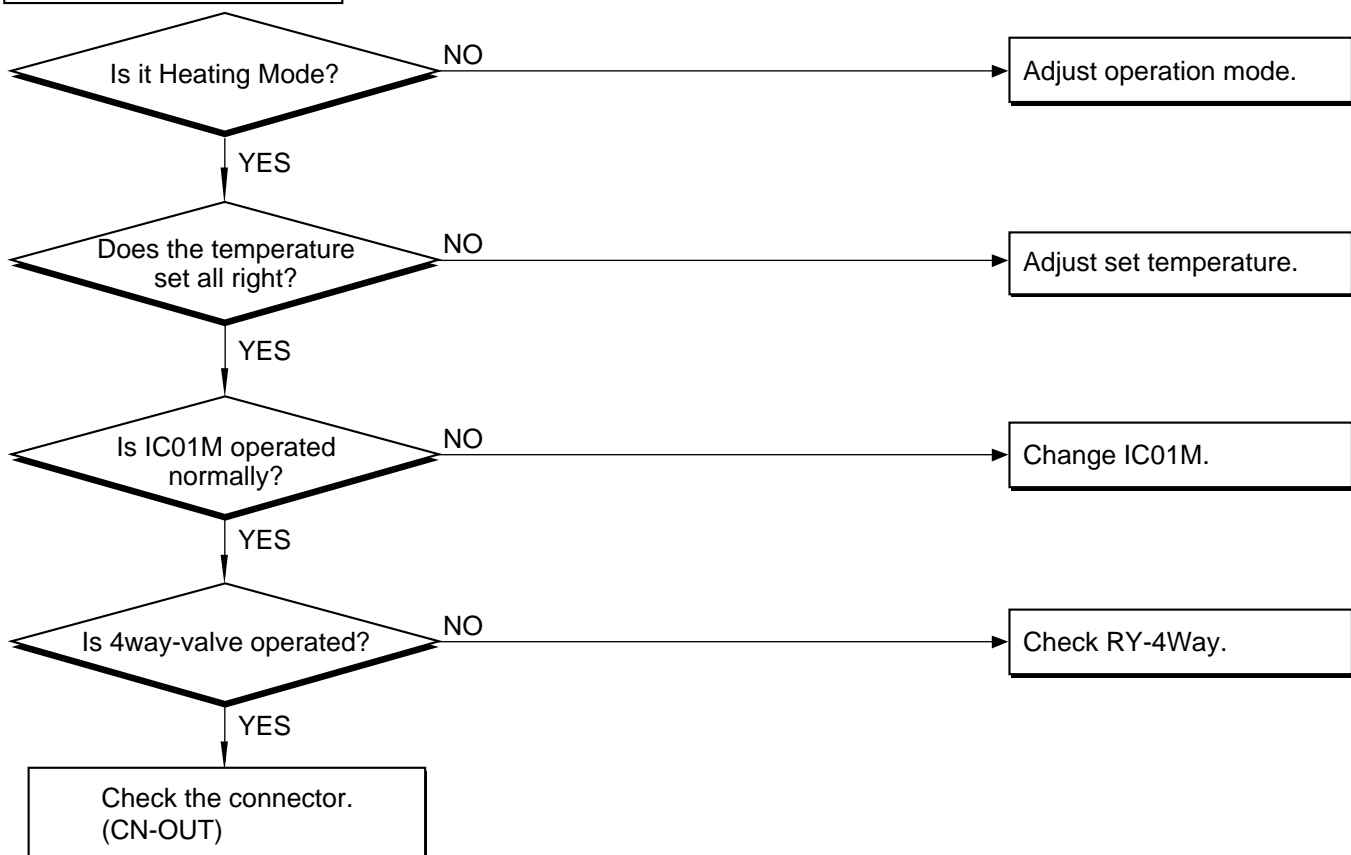

**Possible Trouble 4** : Auto Air direction louver does not operate.



**Possible Trouble 5** : Wired remote controller does not operate.

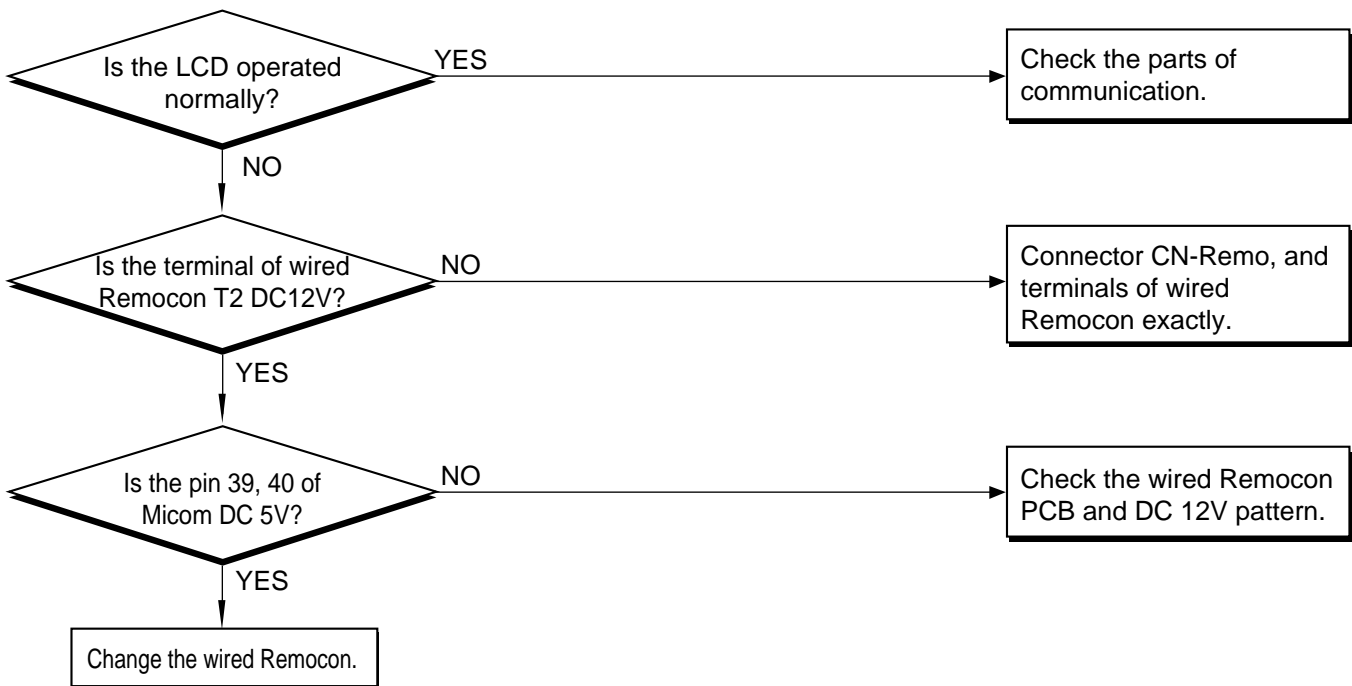



# Schematic Diagram

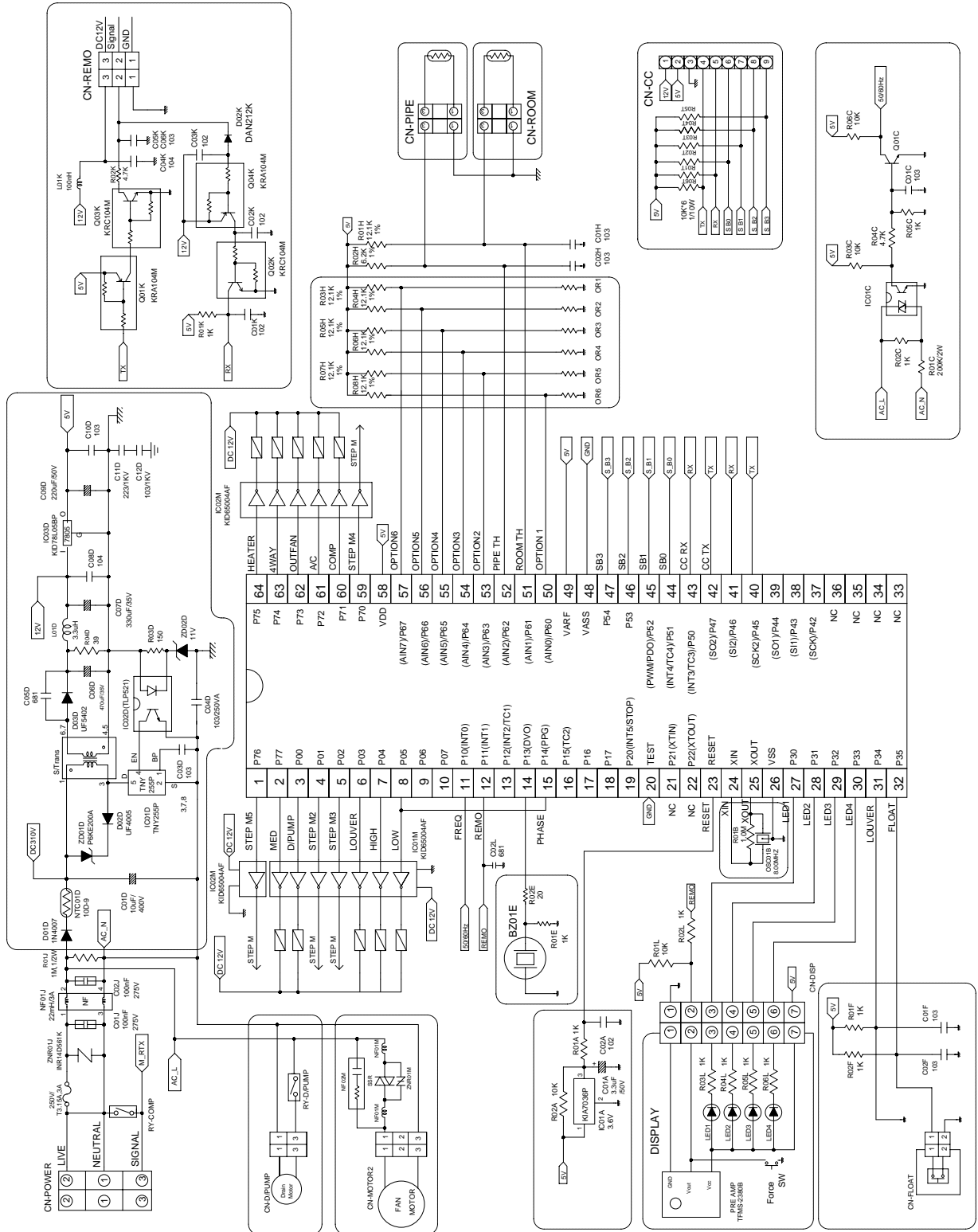

# Exploded View and Replacement Parts List

## 1. Indoor Unit

• Model: LT-E2460FL/FA, LT-E2460RL/RA

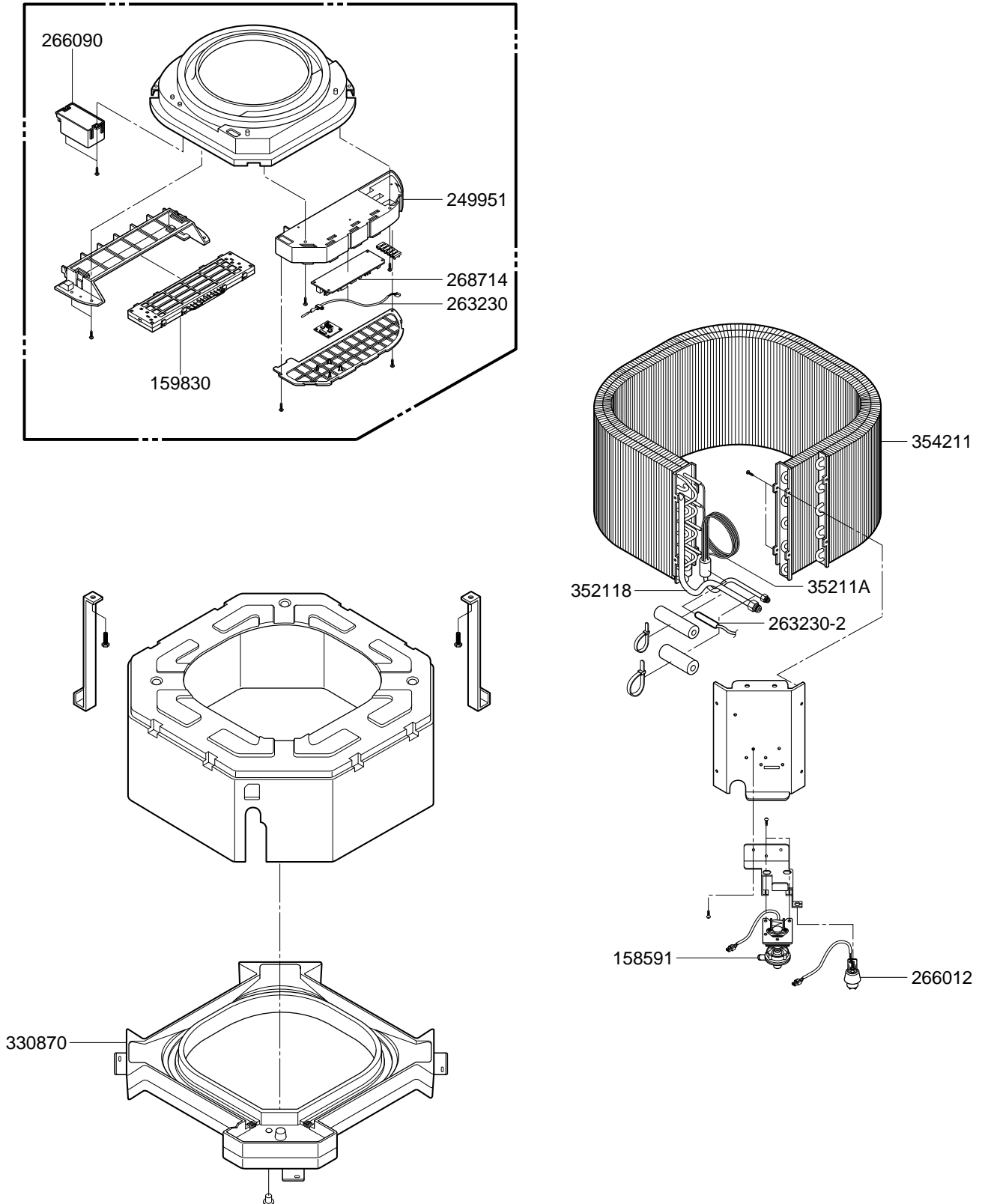

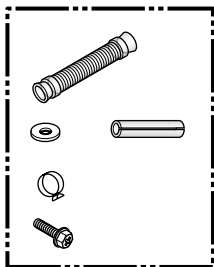
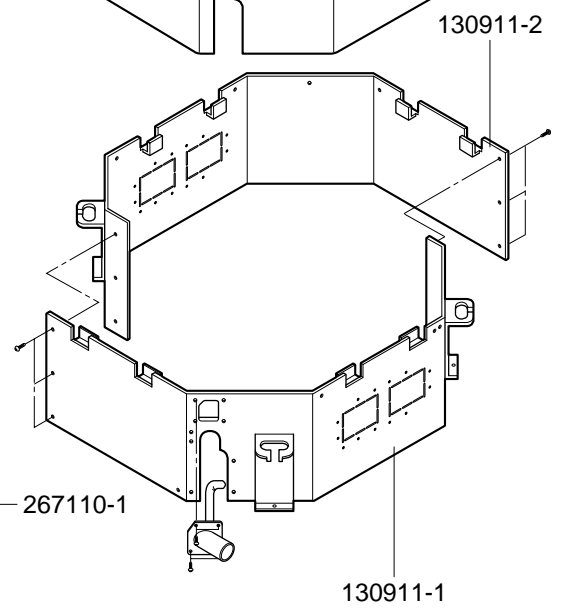
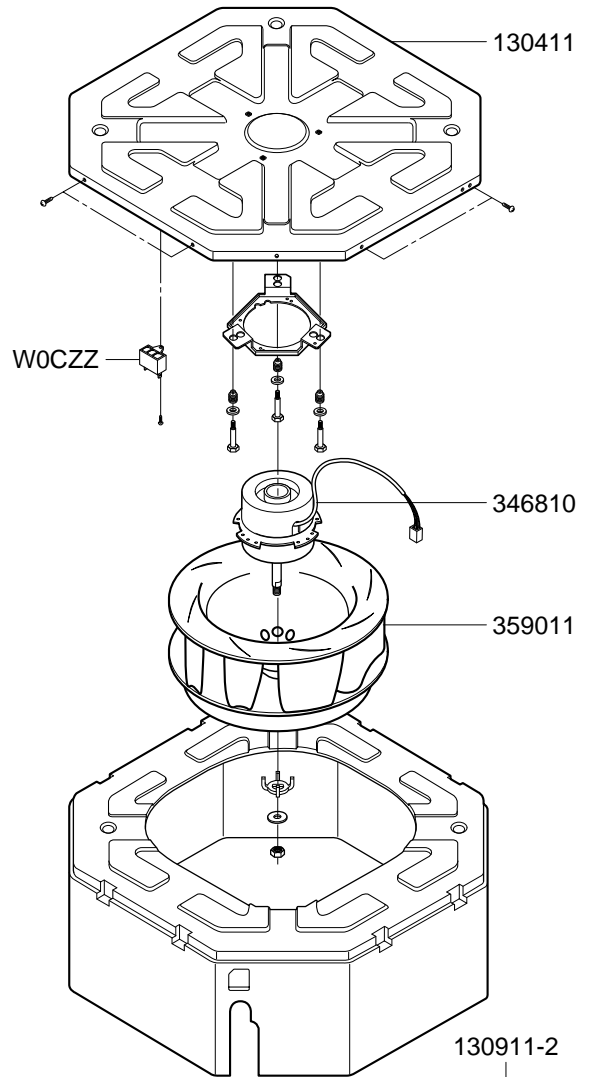
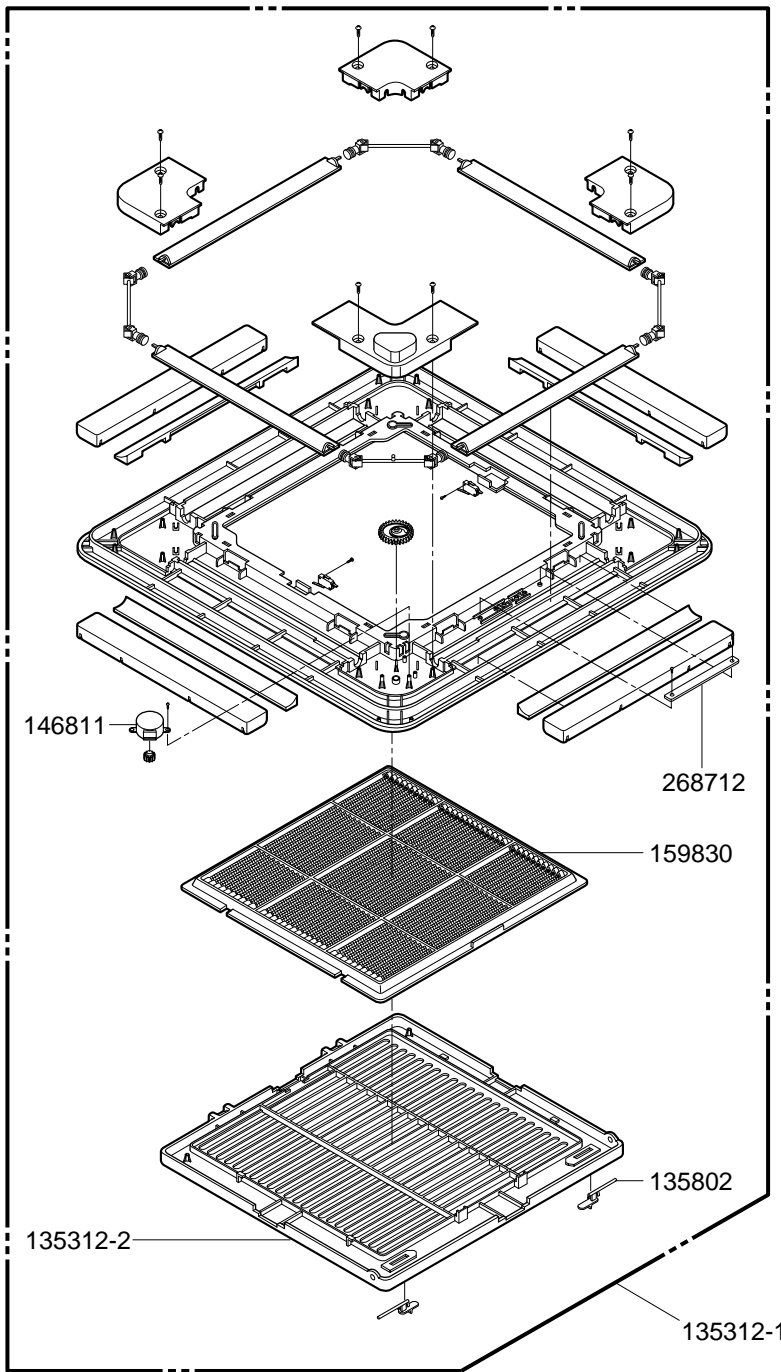

267110-2

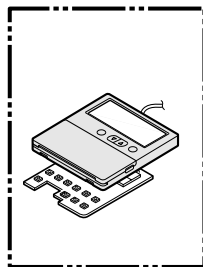
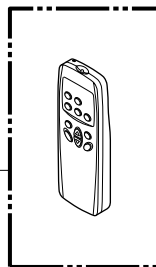

267110-1



• Model: LT-E2460FL/FA, LT-E2460RL/RA

LOCATION NO.	DESCRIPTION	PART NO.				REMARK
		LT-E2460FL	LT-E2460FA	LT-E2460RL	LT-E2460RA	
130411	BASE ASSY, WELD[INDOOR]	3041A10013A	3041A10013A	3041A10013A	3041A10013A	R
135802	DOOR, LOCK	3580A20005A	3580A20005A	3580A20005A	3580A20005A	R
146811	MOTOR ASSY, STEP	4681AP2968D	4681AP2968D	4681AP2968D	4681AP2968D	R
158591	PUMP ASSY, WATER	5859A20001C	5859A20001C	5859A20001C	5859A20001C	R
159820	AIR CLEANER ASSY	-	5983A10002A	-	5983A10002A	R
159830	FILTER ASSY, AIR CLEANER	5231A10005A	5231A10005A	5231A10005A	5231A10005A	R
249951	CONTROL BOX ASSY, INDOOR	4995A10026S	4995A10026S	4995A10026U	4995A10026U	R
266012	SWITCH ASSY, FLOAT	6601A20001F	6601A20001F	6601A20001F	6601A20001F	R
266090	H.V ASSY	-	6609A20005C	-	6609A20005C	R
268712	PWB(PCB) ASSY, DISPLAY	6871A20096C	6871A20096C	6871A20096A	6871A20096A	R
268714	PWB(PCB) ASSY, MAIN	6871A10040C	6871A10040C	6871A10038Z	6871A10038Z	R
330870	DRAIN PAN ASSY	3087A10002A	3087A10002A	3087A10002A	3087A10002A	R
346810	MOTOR ASSY, SINGLE	4681AC2026D	4681AC2026D	4681AC2026D	4681AC2026D	R
352118	TUBE ASSY, MENIFOLD(INDOOR)	5211A20241D	5211A20241D	5211A20241D	5211A20241D	R
354211	EVAPORATOR ASSY, BENDING	5421A10006B	5421A10006B	5421A10006B	5421A10006B	R
359011	FAN, TURBO	5900A10004A	5900A10004A	5900A10004A	5900A10004A	R
130911-1	CABINET ASSY, INDOOR	3091A10023A	3091A10023A	3091A10023A	3091A10023A	R
130911-2	CABINET ASSY, INDOOR	3091A10023B	3091A10023B	3091A10023B	3091A10023B	R
135312-1	PANEL ASSY, FRONT(INDOOR)	3721A10021C	3721A10021S	3721A10021A	3721A10021B	R
135312-2	GRILLE ASSY, FRONT(INDOOR)	3531A10059A	3531A10059A	3531A10059A	3531A10059A	R
263230-1	THERMISTOR ASSY	6323AQ3214N	6323AQ3214N	6323AQ3214N	6323AQ3214N	R
263230-2	THERMISTOR ASSY	6323AQ3226F	6323AQ3226F	6323AQ3226F	6323AQ3226F	R
267110-1	WIRED REMOTE CONTROLLER	6711A10002P	6711A10002Q	6711A10002A	6711A10002B	R
267110-2	REMOTE CONTROLLER ASSY	6711A20039G	6711A20039J	6711A20039H	6711A20039K	R
35211A	TUBE ASSY, SUCTION INDOOR	5211A20243B	5211A20243B	5211A20243B	5211A20243B	R
W0CZZ	CAPACITOR, DRAWING	3H00660N	3H00660N	3H00660N	3H00660N	R
738290	OWNER'S MANUAL	3828A20111P	3828A20111P	3828A20111P	3828A20111P	R
738281	SERVICE MANUAL	3828A20050H	3828A20050H	3828A20050H	3828A20050H	R

## 2. Outdoor Unit

• Model: LT-E2460FL/FA, LT-E2460RL/RA

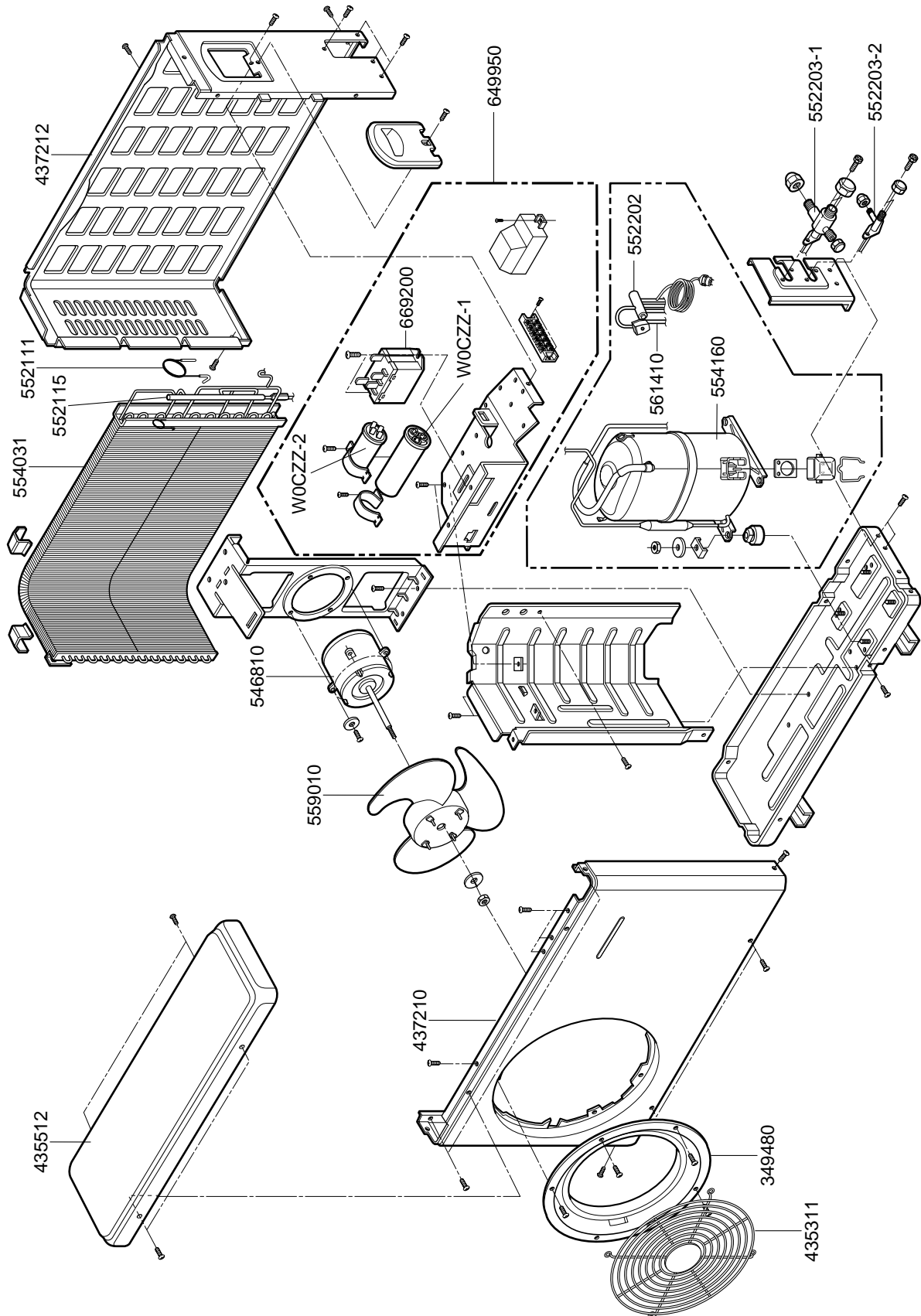

• Model: LT-E2460FL/FA, LT-E2460RL/RA

LOCATION NO.	DESCRIPTION	PART NO.		REMARK
		LT-E2460FL/FA	LT-E2460RL/RA	
435512	COVER	2A00915J	2A00915J	R
349480	ORIFICE	4948AP2527A	4948AP2527A	R
435301	GRILLE, DISCHARGE	3530A20007B	3530A20007B	R
435511	COVER ASSY, CONTROL (OUTDOOR)	3A01919B	3A01919B	R
437210	PANEL, FRONT	1A00196N	1A00196N	R
437212	PANEL ASSY, REAR	3720AP0003L	3720AP0003L	R
546810	MOTOR ASSY, OUTDOOR	4681A20013K	4681A20013K	R
552111	TUBE ASSY, CAPILLARY	5425AR3847Z	5211AP1039R	R
552113	TUBE ASSY, CONDENSER OUT	5211A30225B	5211A30297B	R
552202	VALVE, REVERSING	-	5220AR3228C	R
552203-1	VALVE, SERVICE	5220A20006A	5220A20006A	R
552203-2	VALVE, SERVICE	5220A20007A	2H02479F	R
554031	CONDENSER ASSY, BENT	5403A20022D	5403A20022F	R
554160	COMPRESSOR	5416A20018B	5416A20018B	R
559010	FAN ASSY, PROPELLER	1A00195B	1A00195B	R
561410	COIL ASSY, REVERSING VALVE	-	3A02028Y	R
649950	CONTROL BOX ASSY, OUTDOOR	4995A20167N	4995A20167R	R
W6920	RELAY	6920AP3400A	6920AP3400A	R
W0CZZ-1	CAPACITOR, DRAWING	6120AR2194K	2A00986A	R
W0CZZ-2	CAPACITOR, DRAWING	-	2A00986D	R

