



INSTALLATION MANUAL



COMFORT
size 12-48

ENGLISH

ESPAÑOL

FRANÇAIS

DEUTSCH

NEDERLANDS

PORTUGUÊS

PROVIDING GLOBAL SYSTEM SOLUTIONS



ENGLISH

CONTENT

1. PRECAUTIONS	2
2. INSTALLATION INFORMATION	3
3. ATTACHED FITTINGS.....	4
4. INSTALLATION PLACE	5
5. INDOOR UNIT INSTALLATION.....	6
6. OUTDOOR UNIT INSTALLATION.....	12
7. INSTALL THE CONNECTING PIPE	13
8. CONNECT THE DRAIN PIPE	16
9. INSTALLATION OF FLANGE AND DUCT	17
10. WIRING	19
11. TEST OPERATION	27



1. PRECAUTIONS

SAFETY CONSIDERATIONS

Installation and servicing of air conditioning equipment can be hazardous due to system pressure and electric components. Only trained and qualified service personnel should install, repair or service air conditioning equipment.

All other operations should be performed by trained service personnel. When working on air conditioning equipment, observe precautions in the literature, tags and labels attached to the unit and other safety precautions that may apply. Follow all safety codes. Wear glasses and work gloves. Use quenching cloth for brazing and unbrazing operations. There are fire extinguishers available for all brazing operations.

WARNING

This manual describes the installation of specified indoor and outdoor units. Do not install them connected with any other indoor or outdoor unit. Mismatching of units and incompatibility between control devices in the two units could lead to damage of both units.

WARNING

Before performing service or maintenance operations on system, turn off main power switch of the unit. Electrical shock could cause personal injury.

This unit shall be installed in accordance with national wiring regulations.

WARNING

If the supply cord is damaged, it must be replaced by the manufacturer or its service agent or similarly qualified person in order to avoid a hazard.

The means for disconnection from the supply having a contact separation of at least 3 mm in all poles.

CAUTION

1. Wire the outdoor unit, then wire the indoor unit. You are not allow to connect the air conditioner with the power source until wiring and piping the air conditioner is done.
2. For installation of the indoor unit, outdoor unit, and connection piping in between, follow the instructions given in this manual as strictly as possible.
3. Installation in the following places may cause trouble. If it is unavoidable using in such places, please consult with the dealer.
 - (1) A place full of machine oil.
 - (2) A saline place such as coast.
 - (3) Hot-spring resort.
 - (4) A place full of sulfide gas.
 - (5) A place where there are high frequency machines such as wireless installation, welding machine, medical facilities.
 - (6) A place of special environmental conditions.
4. Don't install this unit in the laundry.

NOTE

Remark per EMC Directive 89/336/EEC

For to prevent flicker impressions during the start of the compressor (technical process), following installation conditions do apply.

1. The power connection for the air conditioner has to be done at the main power distribution. The distribution has to be of a low impedance, normally the required impedance reaches at a 32 A fusing point.
2. No other equipment has to be connected with this power line.
3. For detailed installation acceptance please refer to your contract with the power supplier, if restrictions do apply for products like washing machines, air conditioners or electrical ovens.
4. For power details of the air conditioner refer to the rating plate of the product.
5. For any question contact your local dealer.

2. INSTALLATION INFORMATION

- To install properly, please read this "installation manual" at first.
- The air conditioner must be installed by qualified persons.
- When installing the indoor unit or its tubing, please follow this manual as strictly as possible.
- When all the installation work is finished, please turn on the power only after a thorough check.
- Regret for no further announcement if there is any change of this manual caused by product improvement.

CAUTIONS FOR THE REMOTE CONTROLLER OPERATION

- Please do not throw the remote controller or beat it.
- Please use the remote controller within the allowed distance, and keep the transmitter toward the receiver of the indoor unit.
- Please keep the remote controller more than 1m away from TV or stereo set.
- Never put the remote controller at the place with humid or direct sunlight, or near heaters.
- Please insert the batteries properly.





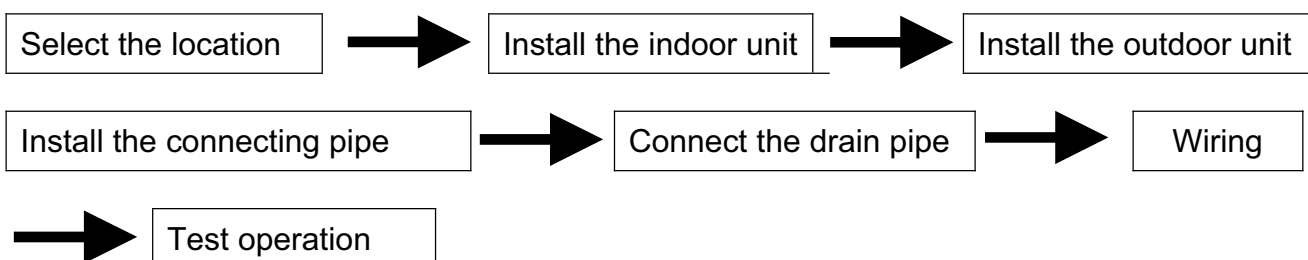





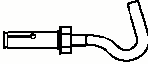





INSTALLATION ORDER

1. Select the location;
2. Install the indoor unit;
3. Install the outdoor unit;
4. Install the connecting pipe;
5. Connect the drain pipe;
6. Wiring;
7. Test operation.

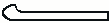

3. ATTACHED FITTINGS

Please check whether the following fittings are of full scope. If there are some attached fittings free from use, please restore them carefully.

Installation Fittings	Tubing & Fittings
1. Expansible hook..... 4 	5. Connecting pipe group1 6. Binding tape.....6 
2. Installation hook 4 	7. Soundproof / insulation sheath2 
3. Installation paper board 1 	
4. Bolt M5 X 16 or M6 X 12..... 4 	
Drainpipe Fittings	Protect Pipe Fittings
8. Out-let pipe sheath..... 1 	13. Wall conduit.....1 
9. Out-let pipe clasp 1 	14. Wall conduit cover1 
10. Tightening band 20 	Others
11. Drain elbow 1 	19. Owner's manual.....1 20. Installation manual.....1
12. Seal ring..... 1 	
Remote controller & Its Frame	
15. Remote controller..... 1 	
16. Frame..... 1 	
17. Mounting screw (ST2.9 x 10-C-H) 2 	
18. Alkaline dry batteries (AM4)..... 2 	

4. INSTALLATION PLACE

CAUTION

Location in the following places may cause malfunction of the machine. (If unavoidable, please consult your local dealer)

- a. There is petrolatum existing.
- b. There is salty air surrounding (near the coast).
- c. There is caustic gas (the sulfide, for example) existing in the air (near a hot spring).
- d. The Volt vibrates violently (in the factories).
- e. In buses or cabinets.
- f. In kitchen where it is full of oil gas.
- g. There is strong electromagnetic wave existing.
- h. There are inflammable materials or gas.
- i. There is acid or alkaline liquid evaporating.
- j. Other special conditions.

NOTICES BEFORE INSTALLATION

1. Select the correct carry-in path.
2. Move this unit as originally packaged as possible.
3. If the air conditioner is installed on a metal part of the building, it must be electrically insulated according to the relevant standards to electrical appliances.

1. The indoor unit

- There is enough room for installation and maintenance.
- The ceiling is horizontal, and its structure can endure the weight of the indoor unit.
- The air outlet and the air inlet are not impeded, and the influence of external air is the least.
- The air flow can reach throughout the room.
- The connecting pipe and drainpipe could be extracted out easily.
- There is no direct radiation from heaters.

2. The outdoor unit

- There is enough room for installation and maintenance.
- The air outlet and the air inlet are not impeded, and can not be reached by strong wind. It must be a dry and well ventilating place.
- The support is flat and horizontal and can stand the weight of the outdoor unit. And will no additional noise or vibration.
- Your neighborhood will not feel uncomfortable with the noise or expelled air. There is no leakage of combustible air.
- It is easy to install the connecting pipe or cables.
- Determine the air outlet direction where the discharged air is not blocked.
- A place free of a leakage of combustible gases.
- In the case that the installation place is exposed to a strong wind such as a seaside or high position, secure the normal fan operation by putting the unit lengthwise along the wall or using a duct or shield plates.
- If possible, do not install the unit where it is exposed to direct sunlight.
- If necessary, install a blind that does not interfere with the air flow.
- During the heating mode, the water drained off the outdoor unit. The condensate should be well drained away by the drain hole to an appropriate place, so as not to interfere other people or public.
- Select the position where it will not be subject to snow drifts, accumulation of leaves or other seasonal debris. It is important that the air flow for the outdoor unit is not impeded as this will result in reduction in heating or cooling performance.

5. INDOOR UNIT INSTALLATION

1. Installation place

- A place where there is enough room for installation and maintenance.(Refer to Chart 1)
- The ceiling is structurally sound to hold the Indoor Unit.
- A place that is well ventilated and the influence of weather is the least.
- A place that the airflow can reach every corners of the room.
- A place where the drain pipe can reach out easily.

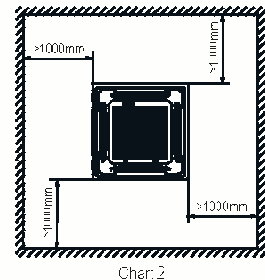
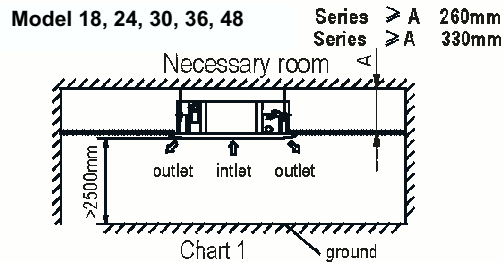
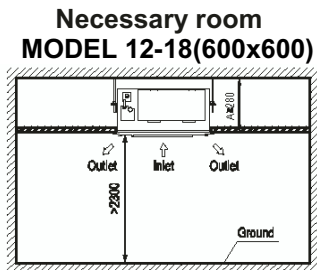

- Install the outdoor unit on a rigid base to prevent increasing noise level and vibration.
- Determine the air outlet direction where the discharged air is not blocked.
- In the case that the installation place is exposed to strong wind such as a seaside or high position, secure the normal fan operation by putting the unit length wise along the wall or using a duct or shield plates.
- Specially in windy area, install the unit to prevent the admission of wind.

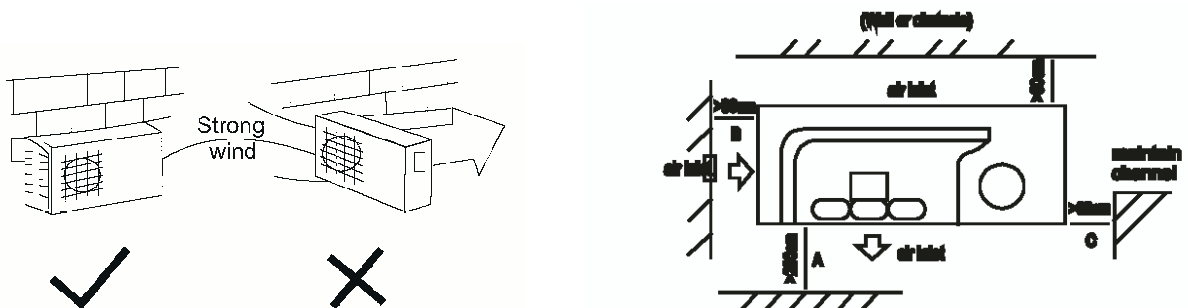

2. Indoor unit installation Model 12-18(600x600)

(1) Install the main body

A. The existing ceiling (to be horizontal)

- Please cut a quadrangular hole of 600X600mm in the ceiling according to the shape of the installation paper board.

The center of the hole should be at the same position of that of the air conditioner body.

Determine the lengths and outlets of the connecting pipe, drain pipe and cables.

To balance the ceiling and to avoid vibration, please enforce the ceiling when necessary.

- Please select the position of installation hooks according to the hook holes on the installation board.

Drill four holes of 12mm, 50~55mm deep at the selected positions on the ceiling. Then embed the expansible hooks (fittings).

Face the concave side of the installation hooks toward the expansible hooks. Determine the length of the installation hooks from the height of ceiling, then cut off the unnecessary part.

If the ceiling is extremely high, please determine the length of the installation hook according to facts.

Cut the installation hook open in the middle position, then use appropriate length of reinforcing rod (φ12) to weld together.

The length could be calculated from Chart5:

Length = 210+L (in general, L is half of the whole length of the installation hook)

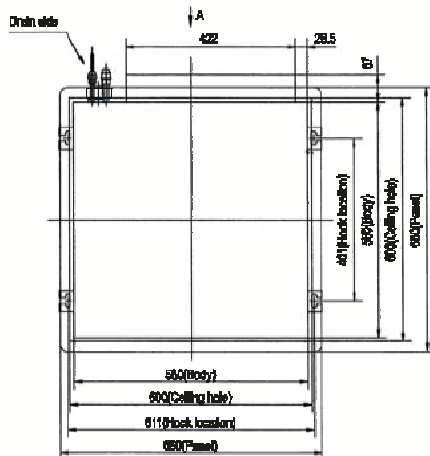

Chart 3

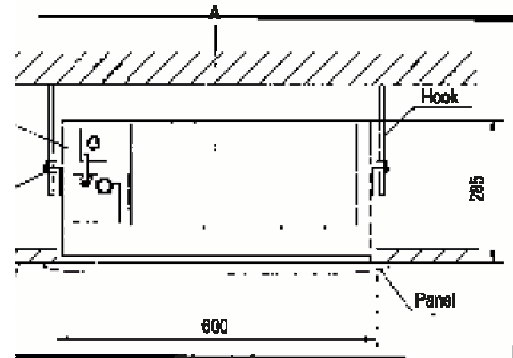

Chart 4

- c. Please adjust the hexangular nuts on the four installation hooks evenly, to ensure the balance of the body.

Use the transparent hose filled with water to check the lever of the main body from the four sides or diagonal line direction, the lever indicator also can check the lever from four sides of the main body. (Refer to chart 6)

If the drainpipe is awry, leakage will be caused by the malfunction of the water-level switch.

Adjust the position to ensure the gaps between the body and the four sides of ceiling are even.

The body's lower part should sink into the ceiling for 10~12mm (Refer to chart5).

Locate the air conditioner firmly by wrenching the nuts after having adjusted the body's position well.

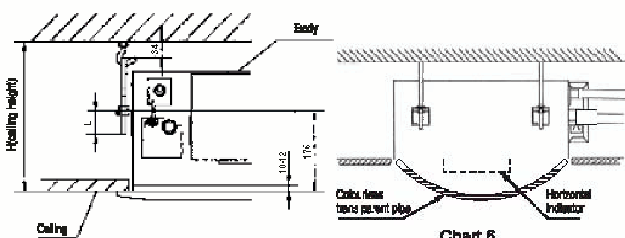

Chart 6

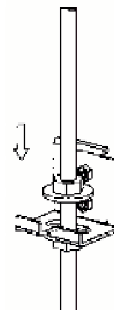

Chart 7

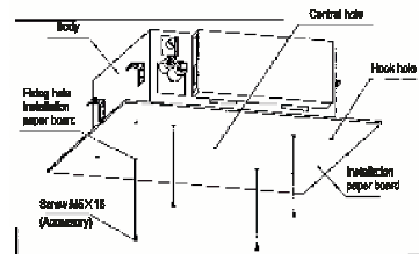

Chart 8

B. New built houses and ceilings

- In the case of new built house, the hook can be embedded in advance (refer to the A.b mentioned above). But it should be strong enough to bear the indoor unit and will not become loose because of concrete shrinking.
- After installing the body, please fasten the installation paper board onto the air conditioner with bolts (M5X16) to determine in advance the sizes and positions of the hole opening on ceiling. Please first guarantee the flatness and horizontal of ceiling when installing it. Refer to the A.a mentioned above for others.
- Refer to the A.c mentioned above for installation.
- Remove the installation paper board.

(2) Install The Panel

Cautions: Never put the panel face down on floor or against the wall, or on bulgy objects.
Never crash or strike it.

1) Remove the inlet grid.

- Slide two grid switches toward the middle at the same time, and then pull them up. (Refer to chart 9)
- Draw the grid up to an angle of about 45, and remove it. (Refer to chart 10)

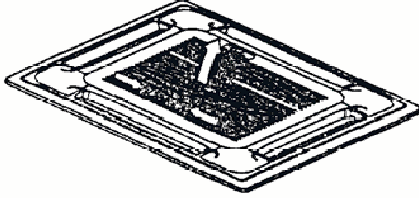

Chart9

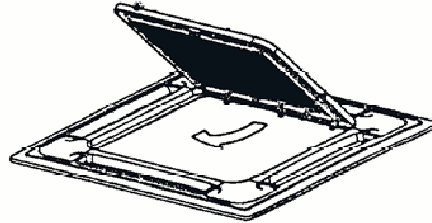

Chart10

2) Install the panel

- Align the swing motor on the panel to the water receiver of the body properly. (Refer to chart 11)
- Hang the four fixed rope of the main body to the installation cover and the other three covers of the swing motor: (Refer to chart 11)

CAUTIONS: The installation cover of the swing motor must sink into the corresponding water receiver.

- Install the panel on the main body with bolt (M5X16) and washer. (Refer to chart 11)
- Adjust the four panel hook screws to keep the panel horizontal, and screw them up to the ceiling evenly.
- Regulate the panel in the direction of the arrow in Chart 11 (3) slightly to fit the panel's center to the center of the ceiling's opening. Guarantee that hooks of four corners are fixed well.
- Keep fastening the screws under the panel hooks, until the thickness of the sponge between the body and the panel's outlet has been reduced to about 4~6mm. The edge of the panel should contact with the ceiling well. (Refer to chart 12)

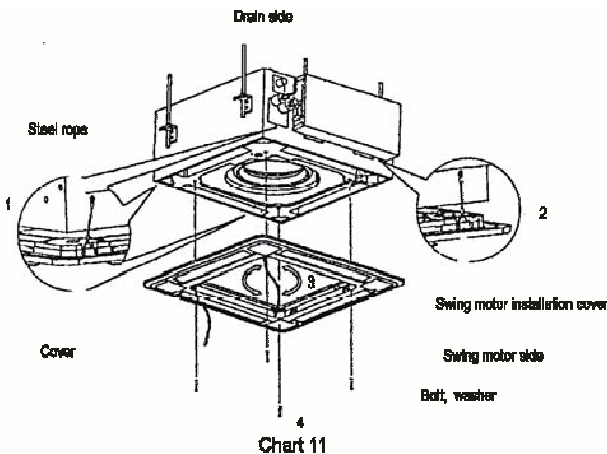

Chart 11

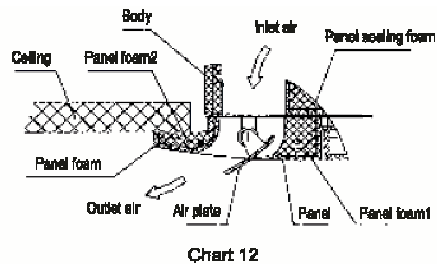

Chart 12

Malfunction described in Chart 13 can be caused by inappropriate tightness the screw.

If the gap between the panel and ceiling still exists after fastening the screws, the height of the indoor unit should be modified again. You can modify the height of the indoor unit through the openings on the panel's four corners, if the lift of the indoor unit and the drainpipe is not influenced (refer to chart 14-right).

- Hang the air-in grid to the panel, then connect the lead terminator of the swing motor and that of the control box with corresponding terminators on the body respectively.

4) Relocate the air-in grid in the procedure of reversed order, install the air-in grid.

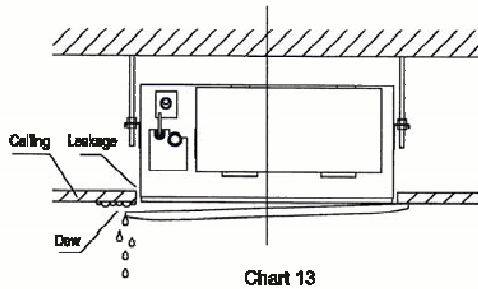

Chart 13

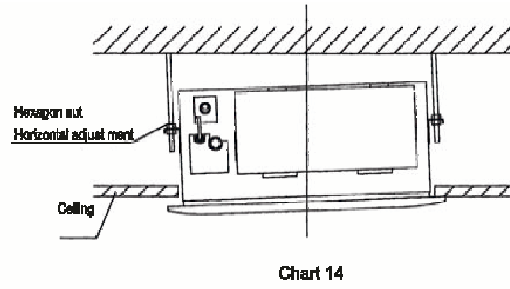

Chart 14

3. Indoor unit installation Model 18-24, 30-36-48

(1) Install the main body

A. The existing ceiling (to be horizontal)

a. Please cut a quadrangular hole of 880X880mm in the ceiling according to the shape of the installation paper board. (Refer to Chart 3, 4)

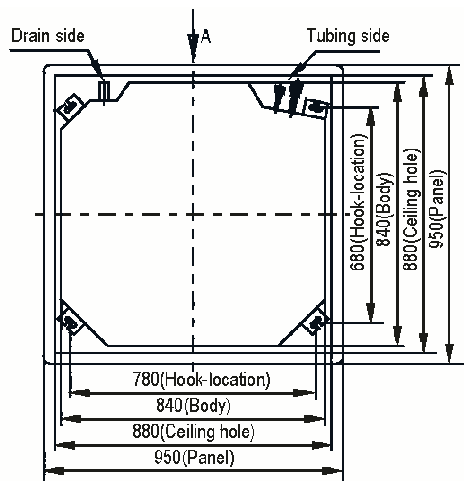

Chart 3

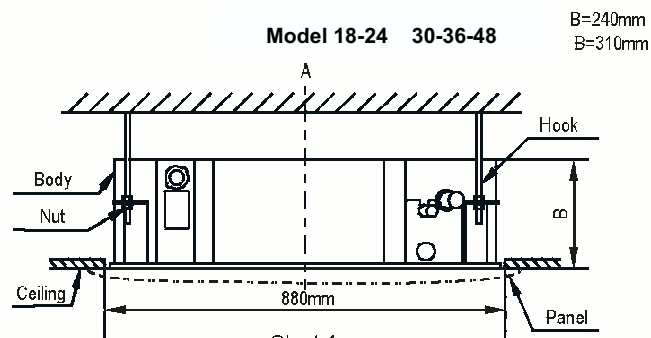

Chart 4

The center of the hole should be at the same position of that of the air conditioner body.

Determine the lengths and outlets of the connecting pipe, drain pipe and cables.

To balance the ceiling and to avoid vibration, please enforce the ceiling when necessary.

b. Please select the position of installation hooks according to the hook holes on the installation board.

Drill four holes of 12mm, 45~50mm deep at the selected positions on the ceiling. Then embed the expansible hooks (fittings).

Face the concave side of the installation hooks toward the expansible hooks. Determine the length of the installation hooks from the height of ceiling, then cut off the unnecessary part.

If the ceiling is extremely high, please determine the length of the installation hook according to facts.

The length could be calculated from Chart5:

Length=H-181+L(in general, L is half of the whole length of the installation hook)

c. Please adjust the hexagonal nuts on the four installation hooks evenly, to ensure the balance of the body.

If the drainpipe is awry, leakage will be caused by the malfunction of the water-level switch.

Adjust the position to ensure the gaps between the body and the four sides of ceiling are even. The body's lower part should sink into the ceiling for 10~12mm (Refer to chart5).

Locate the air conditioner firmly by wrenching the nuts after having adjusted the body's position well.

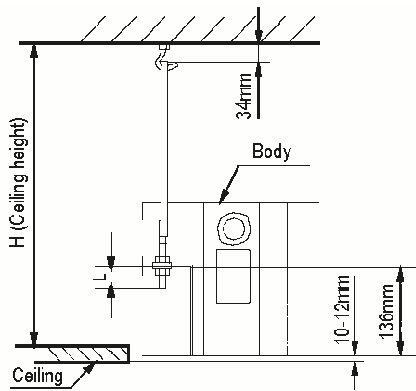

Chart 5

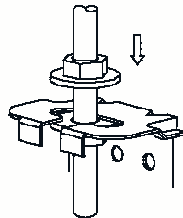

Chart 6

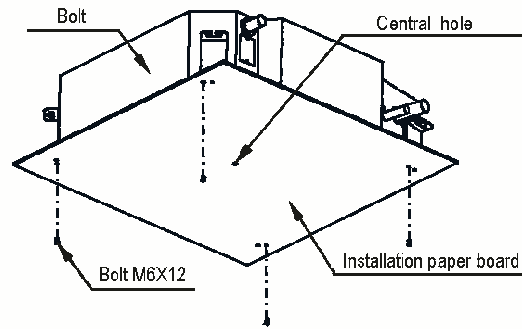

Chart 7

B. New built houses and ceilings

- In the case of new built house, the hook can be embedded in advance (refer to the A.b mentioned above). But it should be strong enough to bear the indoor unit and will not become loose because of concrete shrinking.
- After installing the body, please fasten the installation paper board onto the air conditioner with bolts (M6X12) to determine in advance the sizes and positions of the hole opening on ceiling. Please first guarantee the flatness and horizontal of ceiling when installing it. Refer to the A.a mentioned above for others.
- Refer to the A.c mentioned above for installation.
- Remove the installation paper board.

(2) Install The Panel

1) Remove the inlet grid.

- Slide two grid switches toward the middle at the same time, and then pull them up. (Refer to chart 8)
- Draw the grid up to an angle of about 45, and remove it. (Refer to chart 9)

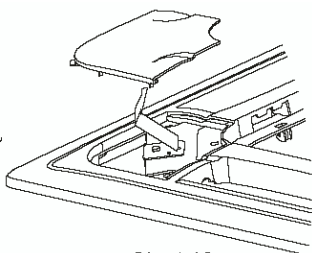

Chart 10

2) Remove the installation covers at the four corners.

Wrench off the bolts, loose the rope of the installation covers, and remove them. (Refer to chart 10)

3) Install the panel

- Align the swing motor on the panel to the tubing joints of the body properly. (Refer to chart 11)
 - Fix hooks of the panel at swing motor and its opposite sides to the hooks of corresponding water receiver. Then hang the other two panel hooks onto corresponding hangers of the body.
- Adjust the four panel hook screws to keep the panel horizontal, and screw them up to the ceiling evenly.

- Regulate the panel in the direction of the arrow in Chart 11(4) slightly to fit the panel's center to the center of the ceiling's opening. Guarantee that hooks of four corners are fixed well.

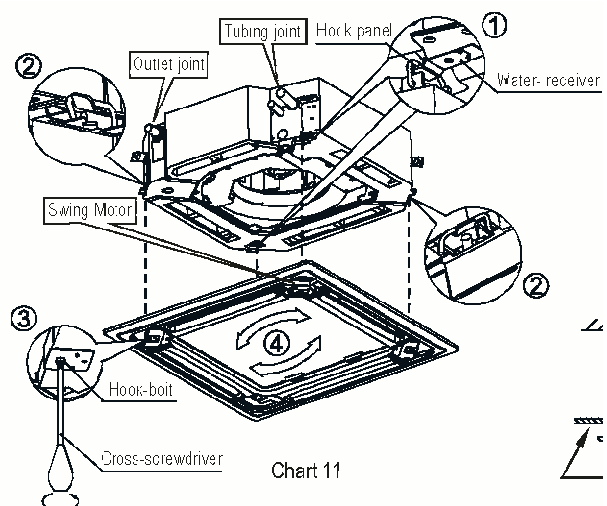

Chart 11

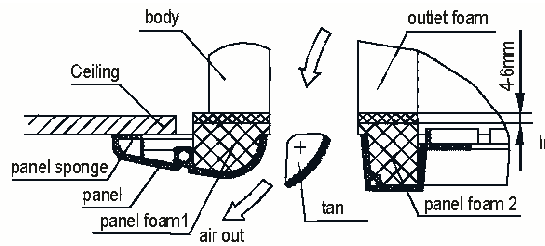

Chart 12

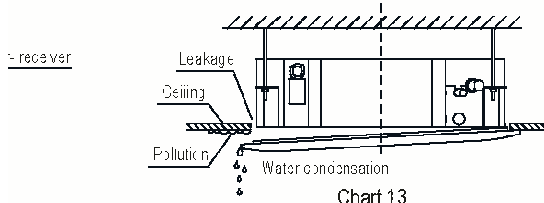

Chart 13

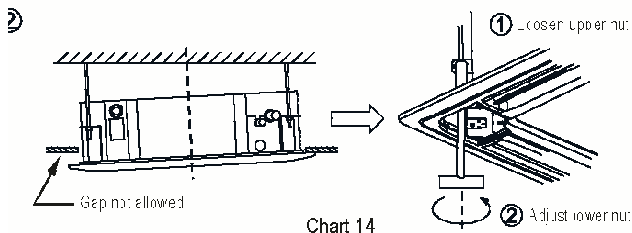

Chart 14

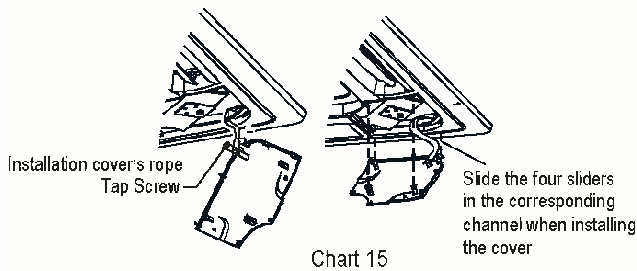

Chart 15

Malfunction described in Chart 13 can be caused by inappropriate tightness the screw.

If the gap between the panel and ceiling still exists after fastening the screws, the height of the indoor unit should be modified again. (Refer to chart 14-left)

You can modify the height of the indoor unit through the openings on the panel's four corners, if the lift of the indoor unit and the drainpipe is not influenced (refer to chart 14-right).

- 4) Hang the air-in grid to the panel, then connect the lead terminator of the swing motor and that of the control box with corresponding terminators on the body respectively.
- 5) Relocate the air-in grid in the procedure of reversed order.
- 6) Relocate the installation cover.
 - a. Fasten the rope of installation cover on the bolt of the installation cover. (Refer to chart 15-left)
 - b. Press the installation cover into the panel slightly. (Refer to chart 15-right)

6. OUTDOOR UNIT INSTALLATION

CAUTION

- Keep this unit away from direct radiation of the sun or other heaters.
- If unavoidable, please cover it with a shelter.
- In places near coast or with a high attitude where the wind is violent, please install the outdoor unit against the wall to ensure normal performance.
- Use a baffle when necessary.
- In the case of extremely strong wind, please prevent the air from flowing backwards into the outdoor unit. (Refer to chart 16)
- Locate the outdoor unit as close to the indoor unit as possible.
- The minimum distance between the outdoor unit and obstacles described in the installation chart does not mean that the same is applicable to the situation of an airtight. Leave open two of three directions A, B, C.

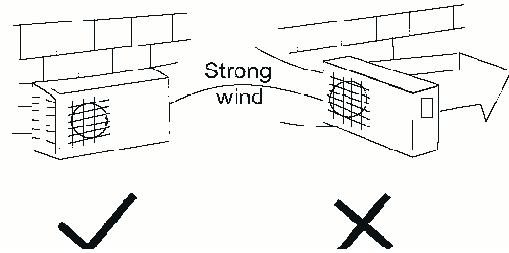

Chart 16

NECESSARY ROOM FOR INSTALLATION AND MAINTENANCE

(Refer to chart 17, chart 18)

If possible, please remove the obstacles nearby to prevent the performance from being impeded by too little of air circulation.

The minimum distance between the outdoor unit and obstacles described in the installation chart does not mean that the same is applicable to the situation of an airtight room. Leave open two of the three directions (A,B,C)

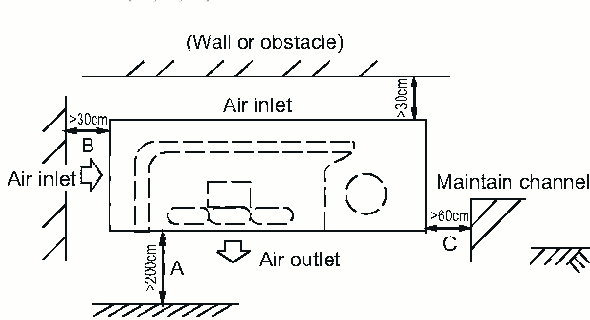

Chart 17

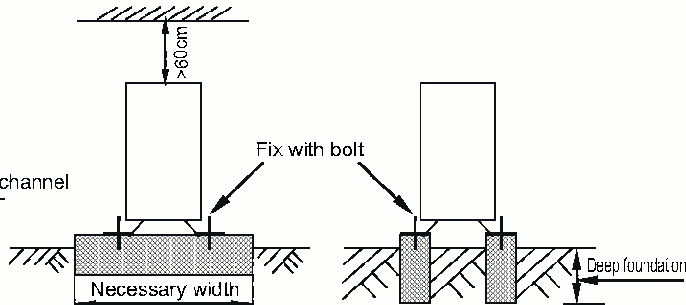

Chart 18

MOVING AND INSTALLING

- Since the gravity center of this unit is not at its physical center, so please be careful when lifting it with a sling.
- Never hold the air-in of the outdoor unit to prevent it from deforming.
- Do not touch the fan with hands or other objects.
- Do not lean it more than 45°, and do not lay it sidelong.
- Please fasten the feet of this unit with bolts firmly to prevent it from collapsing in case of earthquake or strong wind.
- Make concrete foundation of the size of 590*328. (Refer to chart 18)

7. INSTALL THE CONNECTING PIPE

(1) Maximum pipe length

Model	Max. Length	Max. Elevation
(12-18)/(24-48)	25/30m	15/20m

(2) Piping sizes

Model	Liquid (mm/inch)	Gas (mm/inch)
12-18	6.35 (1/4)	12.7 (1/2)
24/30	9.52 (3/8)	16.0 (5/8)
36-48	12.7 (1/2)	19.0 (3/4)

CAUTIONS

- Do not let air, dust, or other impurities fall in the pipe system during the time of installation.
- The connecting pipe should not be installed until the indoor and outdoor units have been fixed already.
- Keep the connecting pipe dry, and do not let moisture in during installation.

The Procedure of Connecting Pipes

1. Measure the necessary length of the connecting pipe, and make it by the following way. (Refer to "Connect The Pipes" for details)

- 1) Connect the indoor unit at first, then the outdoor unit.
- Bend the tubing in proper way. Do not harm to them.

CAUTION

- Daub the surfaces of the flare pipe and the joint nuts with frozen oil, and wrench it for 3~4 rounds with hands before fasten the flare nuts. (Refer to chart 19)
- Be sure to use two wrenches simultaneously when you connect or disconnect the pipes.

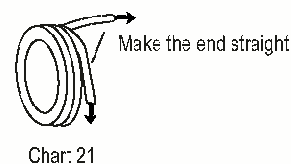
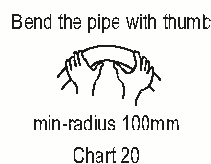
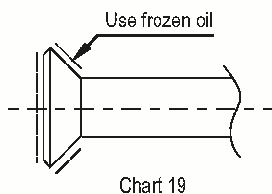

- 2) The stop value of the outdoor unit should be closed absolutely (as original state). Every time you connect it, first loosen the nuts at the part of stop value, then connect the flare pipe immediately (in 5 minutes). If the nuts have been loosened for a long time, dusts and other impurities may enter the pipe system and may cause malfunction later. So please expel the air out of the pipe with refrigerant before connection.
- 3) Expel the air (refer to the "Expel The Air") after connecting the refrigerant pipe with the indoor unit. Then fasten the nuts at the repair-points.

Notices For Bendable Pipe

- The bending angle should not exceed 90.
- Bending position is preferably in the middle of the bendable pipe. The larger the bending radius the better it is.
- Do not bend the pipe more than three times.

Bend the connecting pipe of small wall thickness (Φ 9.53 mm)

- Cut out a desired concave at the bending part of the insulating pipe.
- Then expose the pipe (cover it with tapes after bending).
- To prevent collapsing or deforming, please bend the pipe at its biggest radius.
- Use bender to get a small radius pipes.

Use the market brass pipe

- Be sure to use the same insulating materials when you buy the brass pipe (more than 9mm thick).

2. Locate The Pipes

- Drill a hole in the wall (suitable just for the size of the wall conduit, 53, 71 series diameter is Φ 90mm, and 120, 105, 140 series diameter is Φ 105 in general), then set on the fittings such as the wall conduit and its cover.
- Bind the connecting pipe and the cables together tightly with binding tapes. Do not let air in, which will cause water leakage by condensation.
- Pass the bound connecting pipe through the wall conduit from outside. Be careful of the pipe allocation to do no damage to the tubing.

3. Connect the pipes.

4. Then, open the stem of stop valves of the outdoor unit to make the refrigerant pipe connecting the indoor unit with the outdoor unit in fluent flow.
5. Be sure of no leakage by checking it with leak detector or soap water.
6. Cover the joint of the connecting pipe to the indoor unit with the soundproof / insulating sheath (fittings), and bind it well with the tapes to prevent leakage.

Flaring

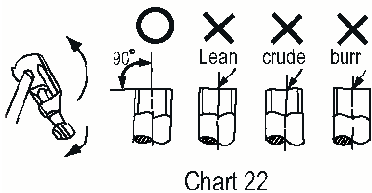

Chart 22

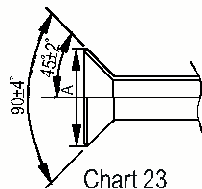

Chart 23

1. Cut a pipe with a pipe cutter.
2. Insert a flare nut into a pipe and flare the pipe.

Outside-diameter (mm)	A(mm)	
	Max	Min
6.35	8.3	8.3
9.53	12.4	12.0
12.7	15.8	15.4
16	19.0	18.6
19	23.3	22.9

Fasten the nuts

- Put the connecting tubing at the proper position, wrench the nuts with hands, then fasten it with a wrench. (Refer to Chart24)

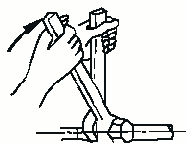

Chart 24

CAUTION

Too large torque will harm the bellmouthing and too small will cause leakage. Please determine the torque according to Table 2.

Tubing Size	Torque
6.35	1420~1720 N · cm (144~176kgf · cm)
9.53	3270~3990 N · cm (333~407kgf · cm)
12.7	4950~6030 N · cm (504~616kgf · cm)
16	6180~7540 N · cm (630~770kgf · cm)
19	9720~11860 N · cm (990~1210kgf · cm)

Table 2

(kg)

Expel the air with a vacuum pump

(Refer to Chart 25)

(Please refer to its manual for the way of using manifold value.)

- Loosen and remove the maintenance nuts of stop values A and B, and connect the charge hose of the manifold value with the maintenance terminator of stop value A. (Be sure that stop values A and B are both closed)
- Connect the joint of the charge hose with the vacuum pump.
- Open the Lo-lever of the manifold value completely.
- Turn on the vacuum pump. At the beginning of pumping, loosen the maintenance terminator nut of stop value B a little to check whether the air comes in (the sound of the pump changes, and the indicator of compound meter turns below zero). Then fasten the nut.
- When the pumping has finished, close the Lo-lever of the manifold value completely and turn off the vacuum pump.
 - When you have pumped for over 15 minutes, please confirm that the indicator of multi-meter is on 1.0×10^{-5} Pa(-76cmHg).
- Loosen and remove the quadrangle cover of stop values A and B to open stop value A and B completely, then fasten them.
- Disassemble the charge hose from the repair-mouth of stop value A, and fasten the nut.

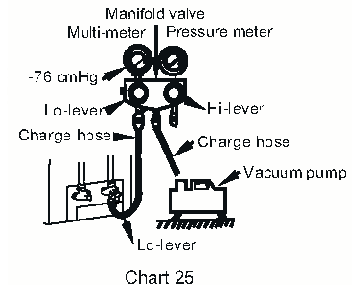

CAUTIONS

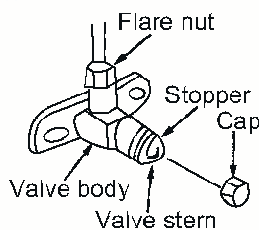

Chart 26

All the stop values should be opened before test operation. Each air conditioner has two stop values of different sizes on the side of the outdoor unit which operate as Lo-stop value and Hi-stop value, respectively. (Refer to Chart 26)

CHECK THE LEAKAGE

Check all the joints with the leak detector or soap water. (refer to Chart 29)

NOTE: in the chart

- A Lo-stop value
- B Hi-stop value
- C,D Joints of the connecting pipe to the indoor unit.

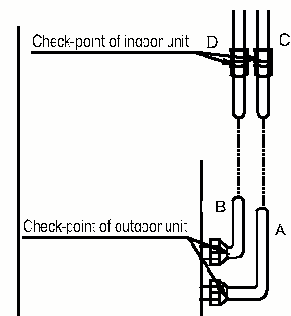

Chart 27

INSULATION

- Be sure to with insulating materials cover all the exposed parts of the flare pipe joints and refrigerant pipe on the liquid-side and the gas-side. Ensure that there is no gap between them.
- Incomplete insulation may cause water condensation.

(3) Additional charge

When the length of the one-way pipe is less than 8m, additional refrigerant charge after vacuuming is not necessary.

When the length of one-way pipe is over 8m, the quantity to be added is as follows (unit in gram):

Connective pipe length	Air purging method	Additional amount of refrigerant to be charged
Less than 8m	Use refrigerant of outdoor unit	
Over 8m	Use vacuum pump or refrigerant cylinder	30g(length-8m) (capacity≤20000btu/h.) 65g(length-8m) (capacity≥24000btu/h.)

8. CONNECT THE DRAIN PIPE

1. Install the drainpipe of the indoor unit

- You can use a polyethylene tube as the drainpipe (out-dia.37-39mm, in-dia.32mm). It could be bought at local market or from your dealer.
- Set the mouth of the drainpipe onto the root of the body's pump-pipe, and clip the drainpipe and the out-let pipe sheath (fittings) together firmly with the out-let pipe clasp (fitting). CAUTIONS: Use your strength carefully to prevent the pump-pipe from breaking.
- The body's pump pipe and the drainpipe (especially the indoor part) should be covered evenly with the out-let pipe sheath (fittings) and be bound tightly with the constrictor to prevent condensation caused by entered air.
- To prevent water from flowing backwards into the air conditioner while the air conditioner stops, please lean the drainpipe down toward outdoor (outlet-side) at a degree of over 1/50. And please avoid any bulge or water deposit. (Refer to Chart 28.a)
- Do not drag the drainpipe violently when connecting to prevent the body from being pulled. Meanwhile, one support-point should be set every 1~1.5m to prevent the drainpipe from yielding (Refer to Chart 28.b). Or you can tie the drainpipe with the connecting pipe to fix it.(Refer to Chart 28.c)
- In the case of prolonged drainpipe, you had better tighten its indoor part with a protection tube to prevent it from loosing.
- If the outlet of the drainpipe is higher than the body's pump joint, the pipe should be arranged as vertically as possible. And the lift distance must be less than 200mm, otherwise the water will overflow when the air conditioner stops.(Refer to Chart 29)

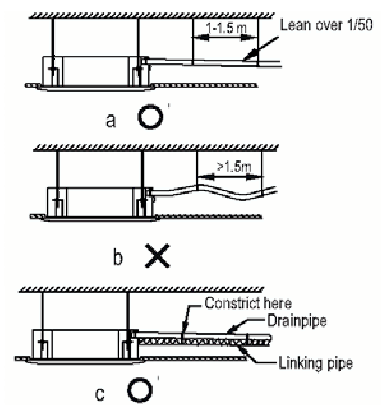

Chart 28

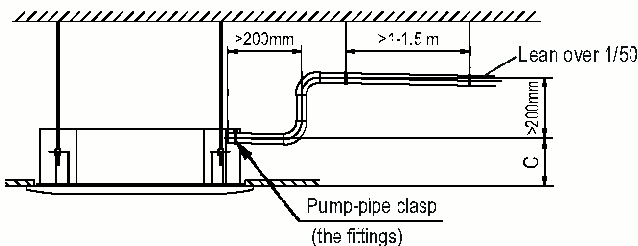

Chart 29

- The end of the drainpipe should be over 50mm higher than the ground or the bottom of the drainage chute, and do not immerse it in water. If you discharge the water directly into sewage, be sure to make a U-form aquaseal by bending the pipe up to prevent the smelly gas entering the house through the drain pipe.

2. Drainage test

- Check whether the drainpipe is unhindered
- New built house should have this test done before paving the ceiling.
 - Remove the test cover, and stow water of about 2000ml to the water receiver through the stow tube. (Refer to Chart 30)
 - Turn on the power, and operate the air conditioner under the "COOLING" mode. Listen to the sound of the drain pump. Check whether the water is discharger well (a lag of 1min is allowed before discharging, according to the length of the drain pipe), and check whether water leaks from the joints.

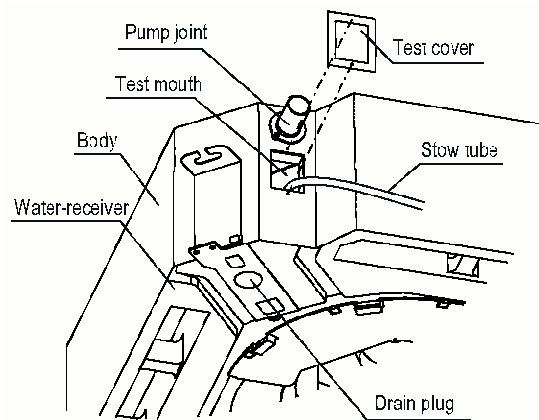

Chart 30

CAUTIONS: If there is any malfunction, please resolve it immediately.

3) Stop the air conditioner, turn off the power, and reset the test cover to its original position.

- The drain plug is used to empty the water-receiver for maintenance of the air conditioner. Please stuff it in position at all times during operation to avoid leakage.

3. Drain Elbow Installation

Fit the seal into the drain elbow, then insert the drain elbow into the base pan hole of outdoor, rotate 90° to securely assemble them. Connect the drain elbow with an extension drain hose (Locally purchased), in case of the condensate draining off the outdoor unit during the heating mode.

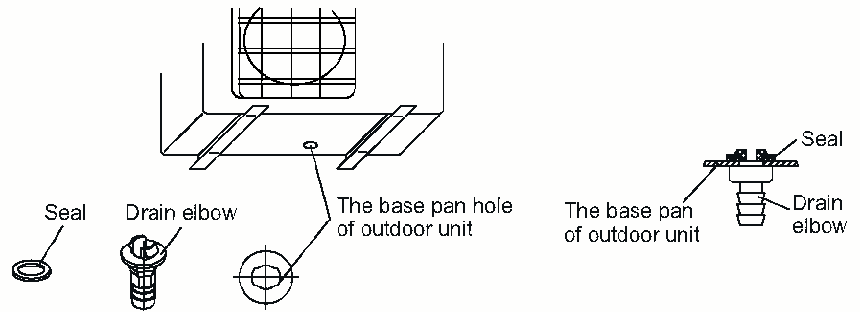
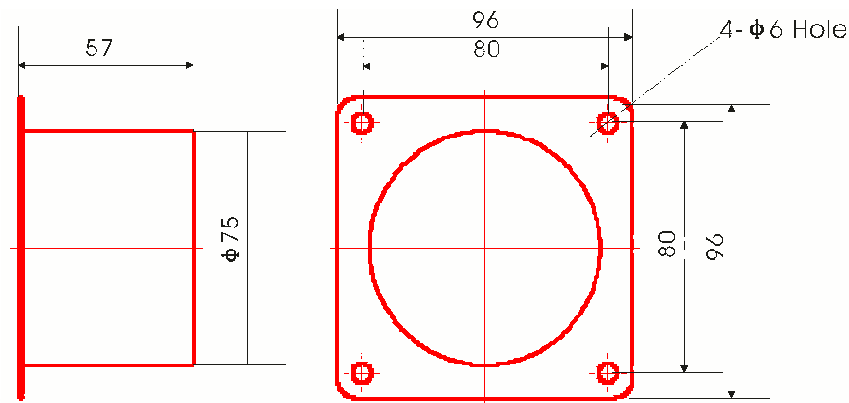

Chart 31

9. INSTALLATION OF FLANGE AND DUCT

Fresh air is intaken by indoor fan motors or ductable fan motor devices on field. The positions of fresh air intake can be changed according to the installation of ductable fan motor.



Note:

1. The device can be installed in ceiling cassette type indoor units (several-direction flow).
2. When installing the device, duct is needed on field and the rated diameter is 75mm.

When metal duct pass through wooden wall, electric insulation must be add between duct and wall. The duct must be pulled out downside to prevent rain and water entering. Net cover must be set at places where duct explodes to outdoor air to prevent birds and animals entering.

For different type of indoor units, the installation methods are different and the position of holes are different.

1. Removal the hole on the board.

Installation Type 1
The hole is oppo to drainage pipe

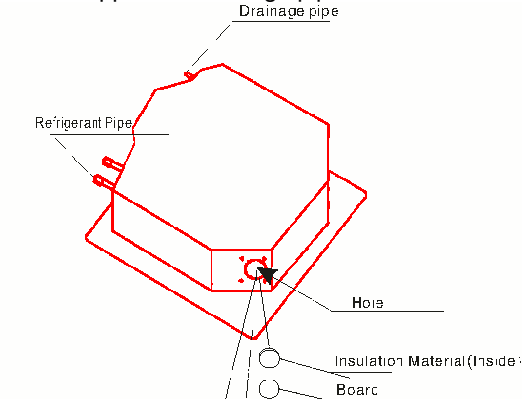

Installation Type 2
The hole is oppo to refrigerant pipe

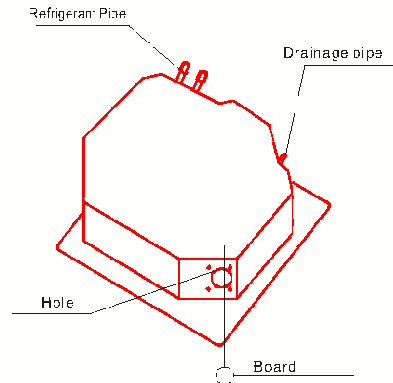

Stick insulator material 4 at indoor hole

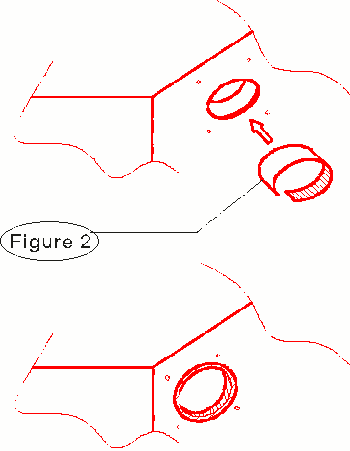
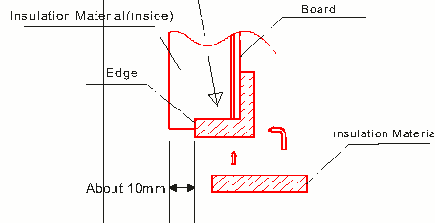

Figure 2

Installation Type 1

Put the insulation material 4 on the interface of the hole as shown in Figure 4, then stick on the inside and surface of the board. The interface of the hole can not have gap.



Installation Type 2

Stick insulation material 4 at the opening part of the board

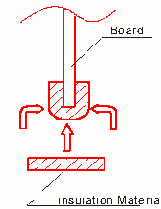

Ensure the interface of insulation material 4 closely contacts with the inside insulation material and the board.

Use screw 2 (M4X12, 4 Pieces) to install flange at the hole, and then stick insulation material 3.

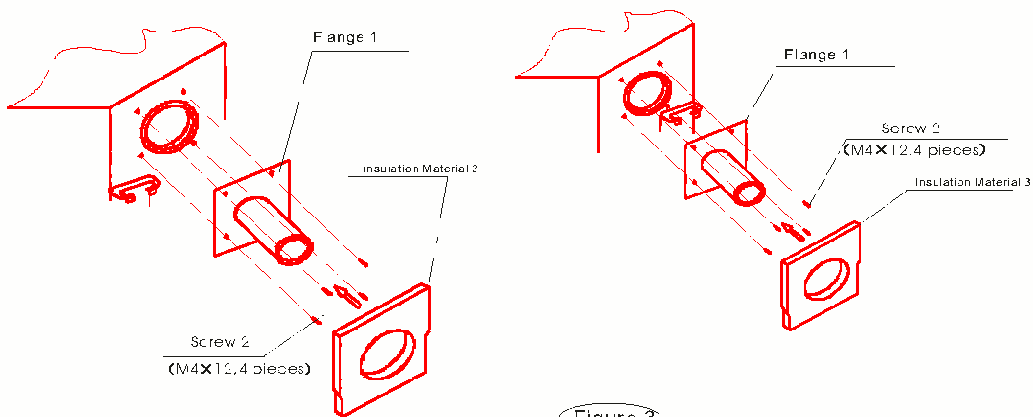
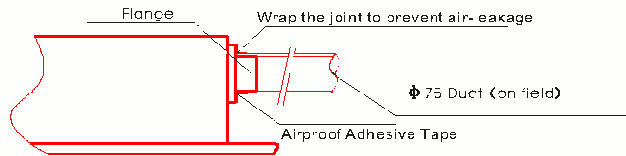

Figure 3

Install Duct (the rated diameter: $\Phi 75$)

1. Connect the duct to the flange.(the flange is assembled with the interface of duct.)
2. After connection, use the ethylene tape (provided on field) to wrap the joint to prevent air-leakage.



Note:

1. All ducts must be completely heat-insulated.
2. The following phenomenon are not allowed when installing duct:

A) Bend too much

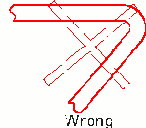

B) Too many ber de

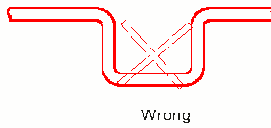

C) diameter reduce

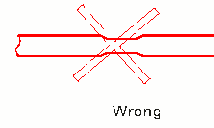

10. WIRING

Please refer to the Wiring Diagram

CAUTION

1. The air conditioner should use separate power supply with rated voltage.
2. The external power supply to the air conditioner should have ground wiring, which is linked to the ground wiring of the indoor and outdoor unit.
3. The wiring work should be done by qualified persons according to circuit drawing.
4. A disconnection device having an air gap contact separation in all active conductors should be incorporated in the fixed wiring according to the National wiring regulation.
5. Be sure to locate the power wiring and the signal wiring well to avoid cross-disturbance and their contact with connecting pipe or stop valve body.
6. The wiring attached to this air conditioner is 6m long. Be sure to prolong it with wiring of the same type and proper length if necessary. Generally, do not twist two wiring together unless the joint is soldered well and covered with insulator tape.
7. Do not turn on the power until you have checked carefully after wiring.

1. The Specification of Power

MODEL		MODEL 12-18 (For R407C and R410A, Heating&Cooling)	MODEL 24 (For R407C and R410A, Heating&Cooling)	MODEL 24-36 (For R407C and R410A, Heating&Cooling)
POWER	PHASE	1-PHASE	1-PHASE	3-PHASE
	FREQUENCY AND VOLT	220-240V~, 50Hz	220-240V~, 50Hz	380V 3N~, 50Hz
CIRCUIT BREAKER/FUSE (A)		30/25	40/25	20/15
INDOOR UNIT POWER WIRING (mm ²)		3x1.5	3x2.5	5x1.5
INDOOR/ OUTDOOR CONNECTING WIRING (mm ²)	GROUND WIRING	1.5	2.5	1.5
	OUTDOOR UNIT POWER WIRING	5x1.5	3x2.5	5x1.5
	STRONG ELECTRIC SIGNAL	-----	3x1.0	4x1.0
	WEAK ELECTRIC SIGNAL	1-core shield wire 1x0.5	1-core shield wire 1x0.5	2-core shield wire 2x0.5



MODEL		MODEL 30-36 (For R407C and R410A, Heating&Cooling)	MODEL 36-48 (For R407C and R410A, Heating&Cooling)
POWER	PHASE	1-PHASE	3-PHASE
	FREQUENCY AND VOLT	220-240V~, 50Hz	380V 3N~, 50HZ
CIRCUIT BREAKER/FUSE (A)		40/25	25/15
INDOOR UNIT POWER WIRING (mm ²)		3x3.5	5x2.5
INDOOR/OUTDOOR CONNECTING WIRING (mm ²)	GROUND WIRING	3.5	2.5
	OUTDOOR UNIT POWER WIRING	3x3.5	5x2.5
		STRONG ELECTRIC SIGNAL	3x1.0
		WEAK ELECTRIC SIGNAL	1-core shield wire 1x0.5

MODEL		MODEL 18 (For R407C and R410A, Cooling only)	MODEL 24 (For R407C and R410A, Cooling only)	MODEL 24-30 (For R407C and R410A, Cooling only)
POWER	PHASE	1-PHASE	1-PHASE	3-PHASE
	FREQUENCY AND VOLT	220-240V~, 50Hz	220-240V~, 50Hz	380V 3N~, 50Hz
CIRCUIT BREAKER/FUSE (A)		30/25	40/25	20/15
INDOOR UNIT POWER WIRING (mm ²)		3x2.0	3x2.5	5x1.5
INDOOR/OUTDOOR CONNECTING WIRING (mm ²)	GROUND WIRING	2.0	2.5	1.5
	OUTDOOR UNIT POWER WIRING	4x2.0	3x2.5	5x1.5
	STRONG ELECTRIC SIGNAL		2x1.5	3x1.5
	WEAK ELECTRIC SIGNAL	-----	-----	2-core shield wire 2x0.5

MODEL		MODEL 30-36 (For R407C and R410A, Cooling only)	MODEL 36-48 (For R407C and R410A, Cooling only)
POWER	PHASE	1-PHASE	3-PHASE
	FREQUENCY AND VOLT	220-240V~, 50Hz	380V 3N~, 50Hz
CIRCUIT BREAKER/FUSE (A)		40/25	25/10
INDOOR UNIT POWER WIRING (mm ²)		3x3.5	5x2.5
INDOOR/OUTDOOR CONNECTING WIRING (mm ²)	GROUND WIRING	3.5	2.5
	OUTDOOR UNIT POWER WIRING	3x3.5	5x2.5
	STRONG ELECTRIC SIGNAL	2x2.5	2x1.0
	WEAK ELECTRIC SIGNAL	-----	-----

2. Remove the protection board.

Disassemble the bolts from the maintenance board, and pull it in the direction of the arrow to remove the protection board.

Notice: Do not scratch the surface during operation.

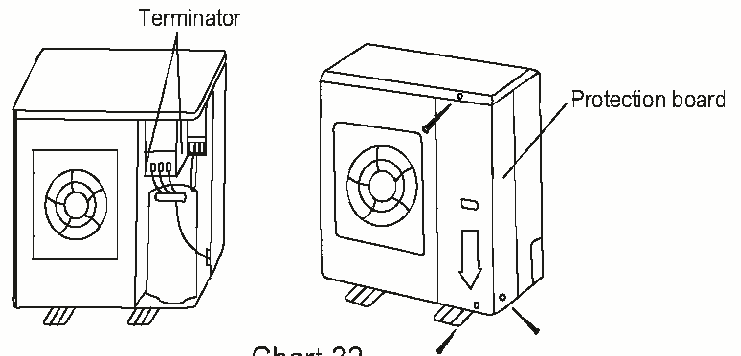

Chart 32

ATTENTION: Chart 32 is based on the standard model, which may look a little different from your own outdoor unit.

Wiring chart

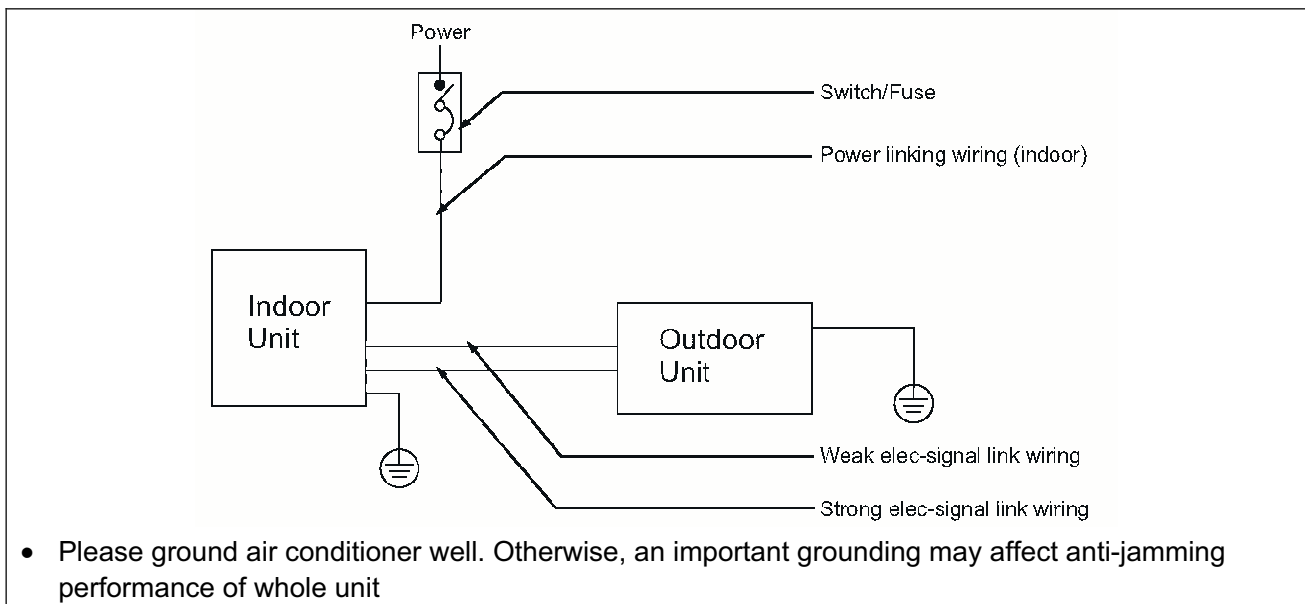

Chart 33

CAUTION: The wiring chart of both cooling only type and cooling & heating type in R22, R407C and R410A series are shown as follows. When wiring, please choose the corresponding chart, or it may cause damage.

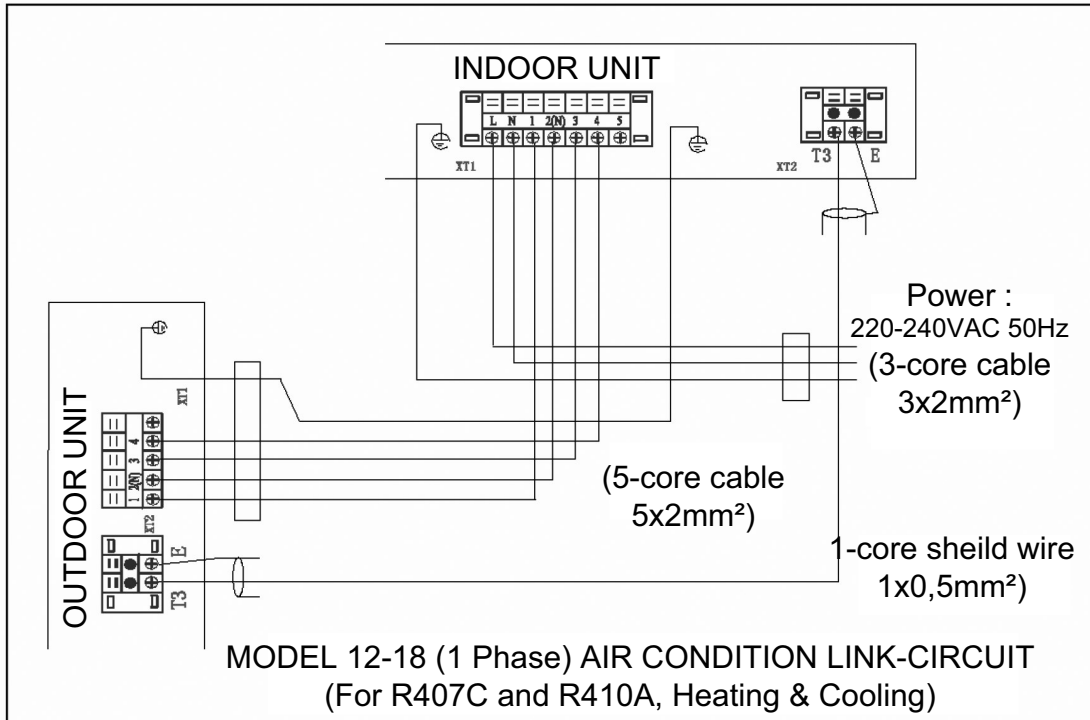

Chart 34

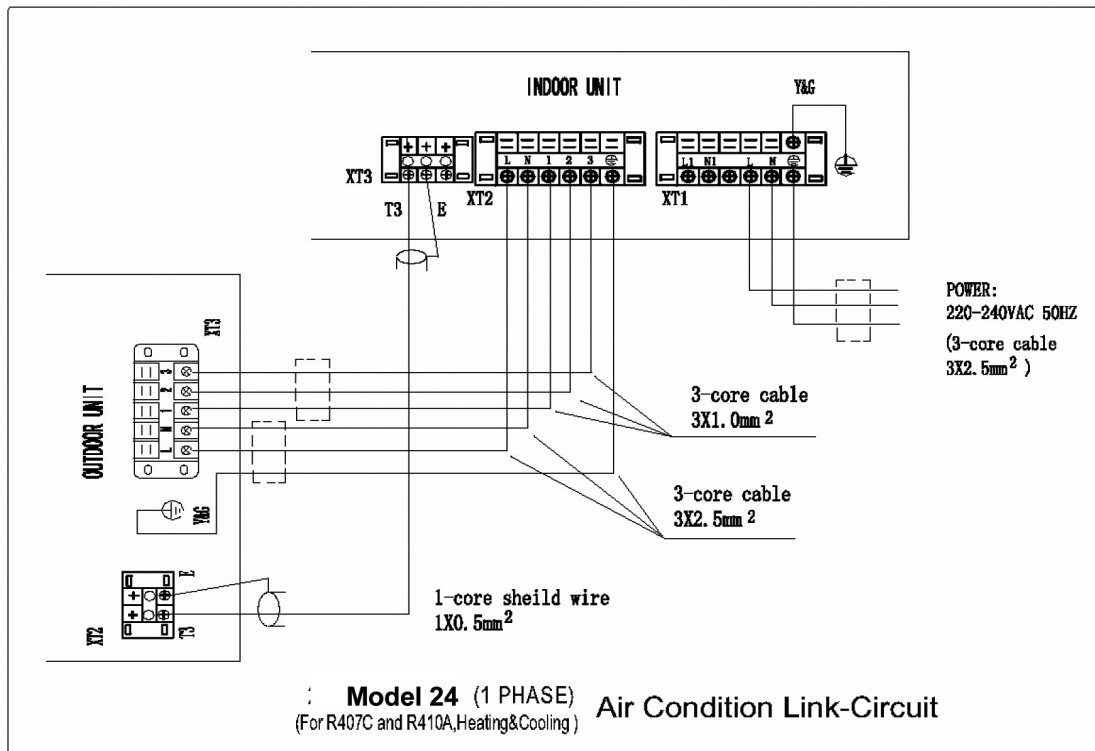

Chart 35

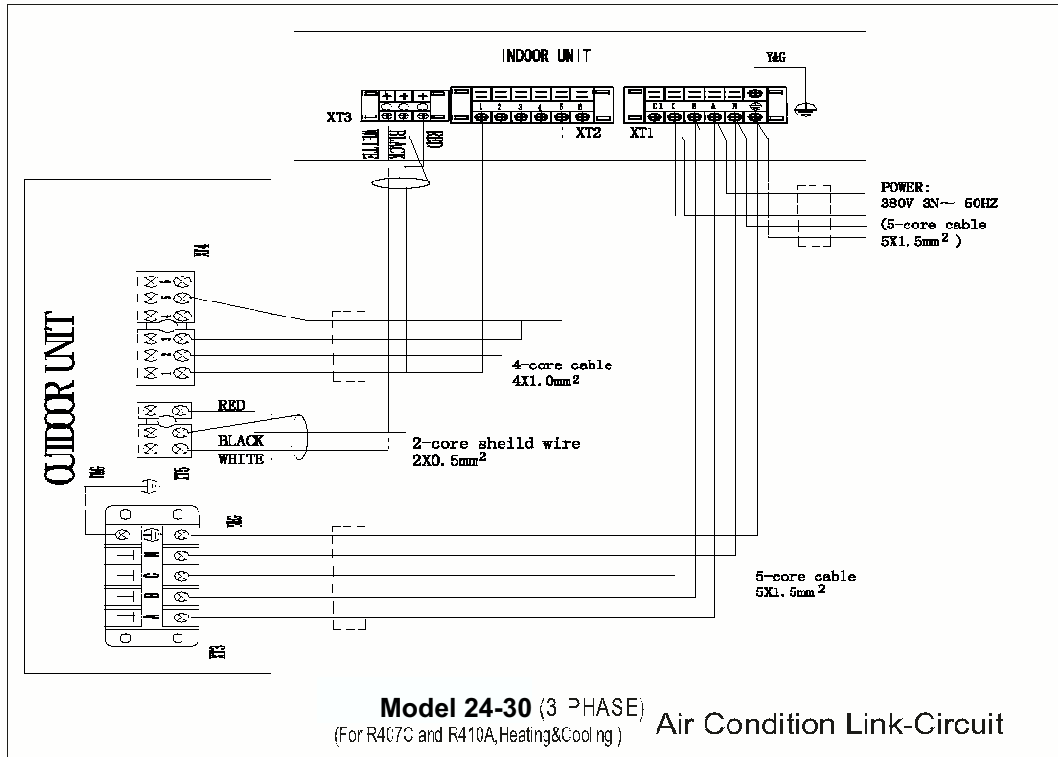

Chart 36

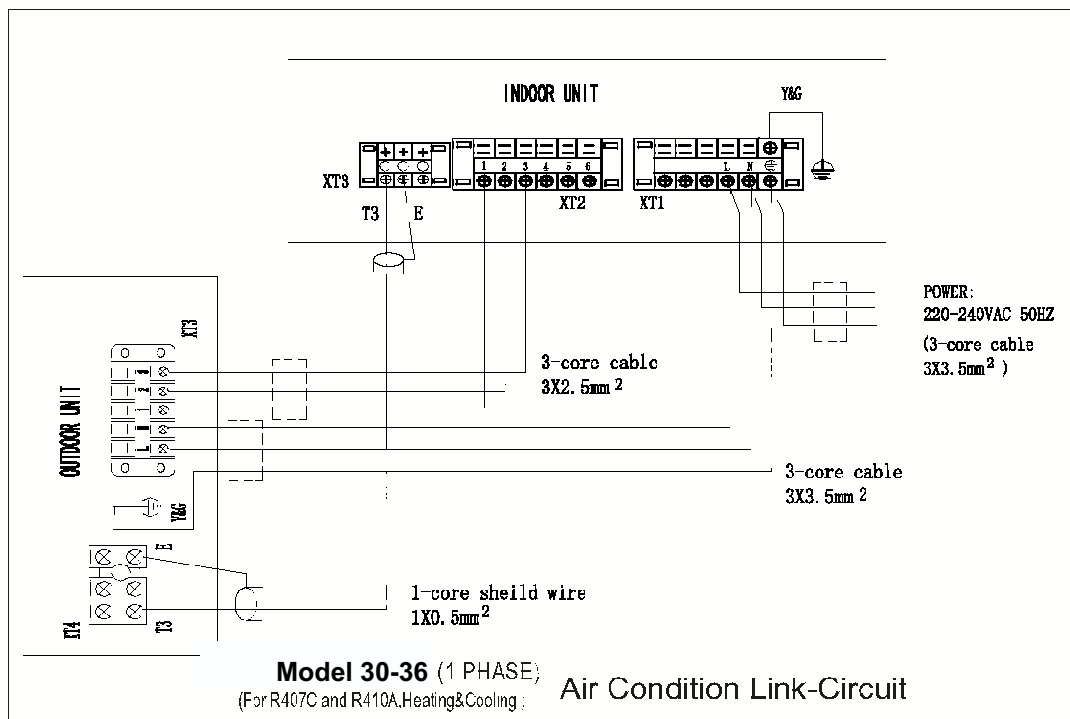

Chart 37

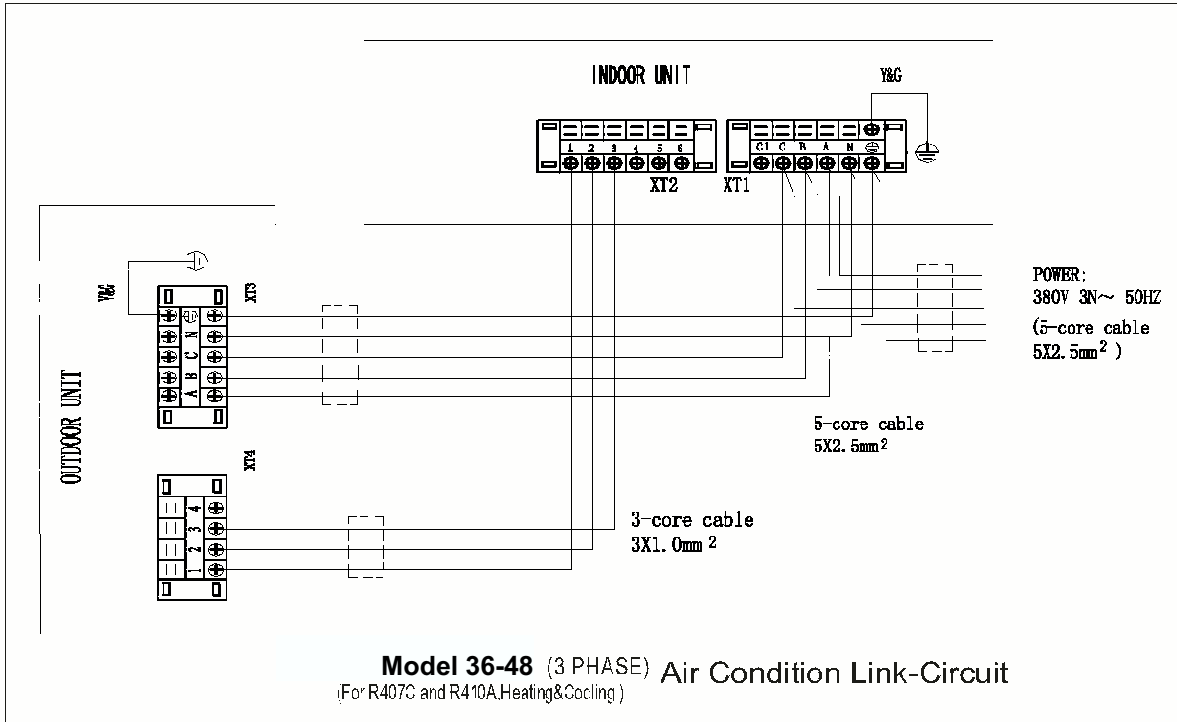

Chart 38

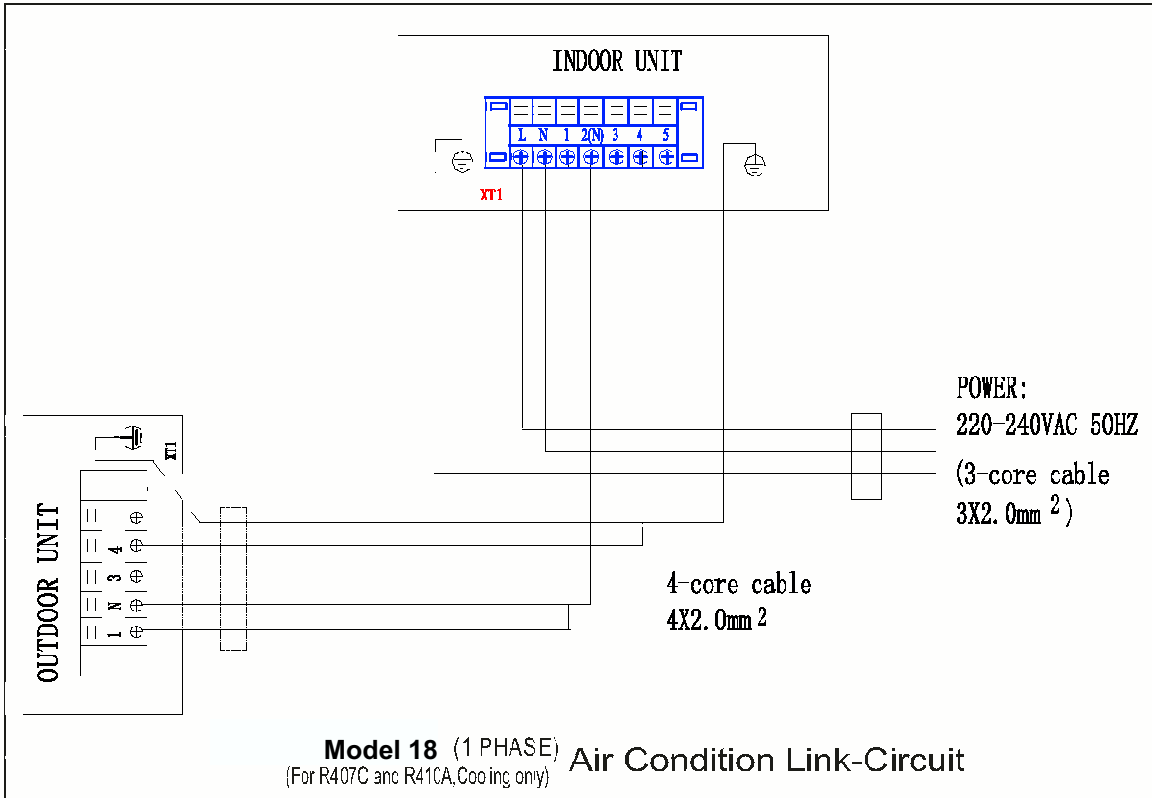

Chart 39

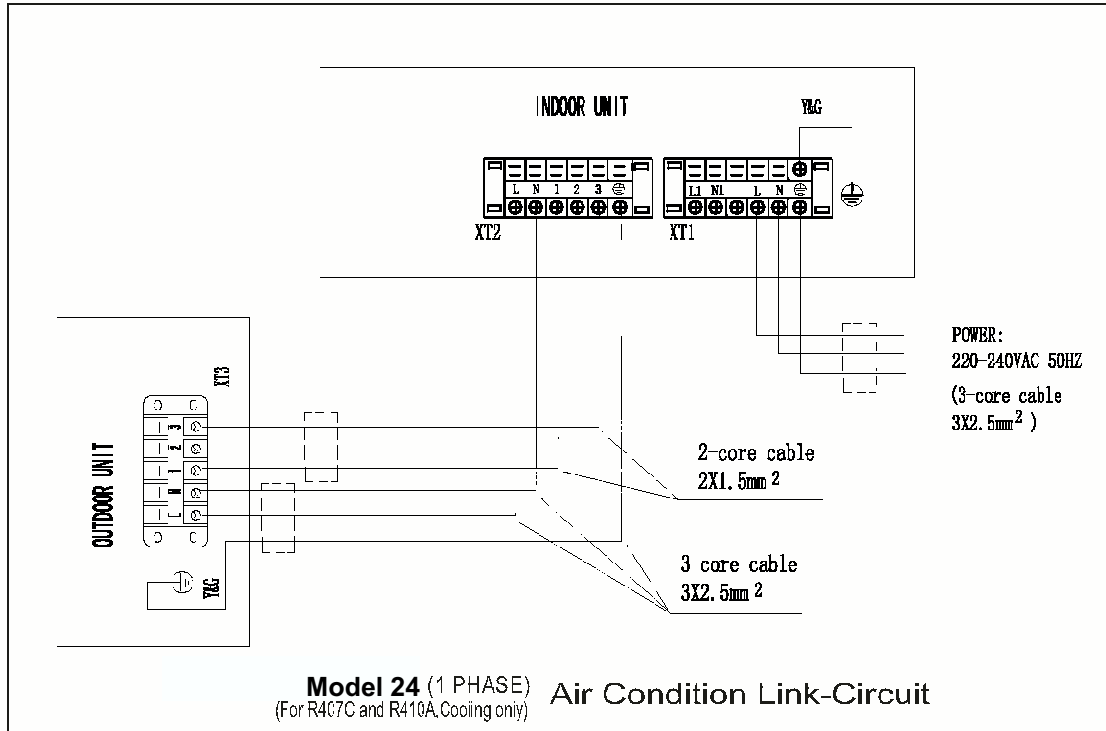

Chart 40

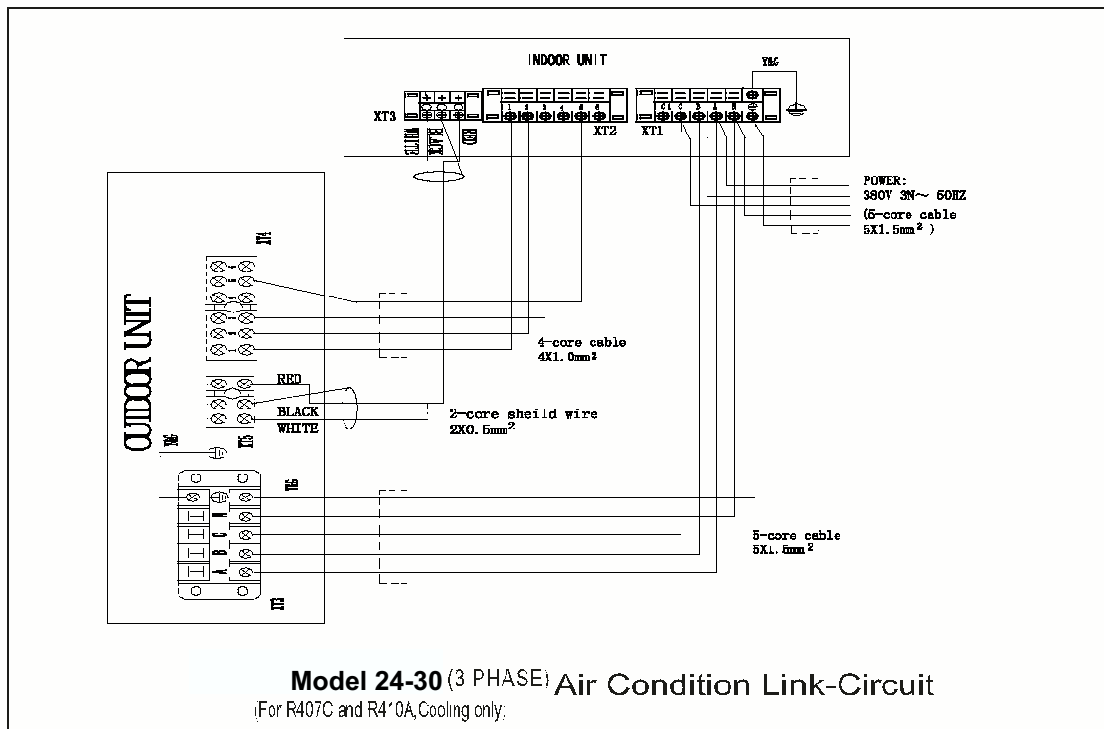

Chart 41

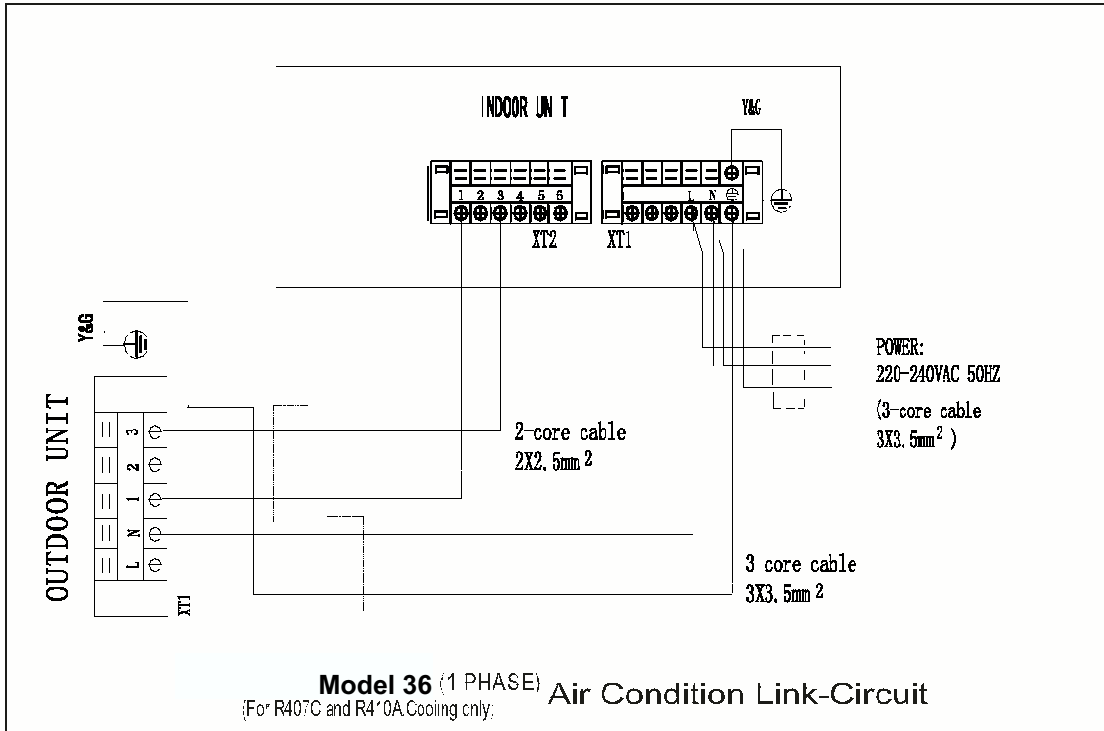

Chart 42

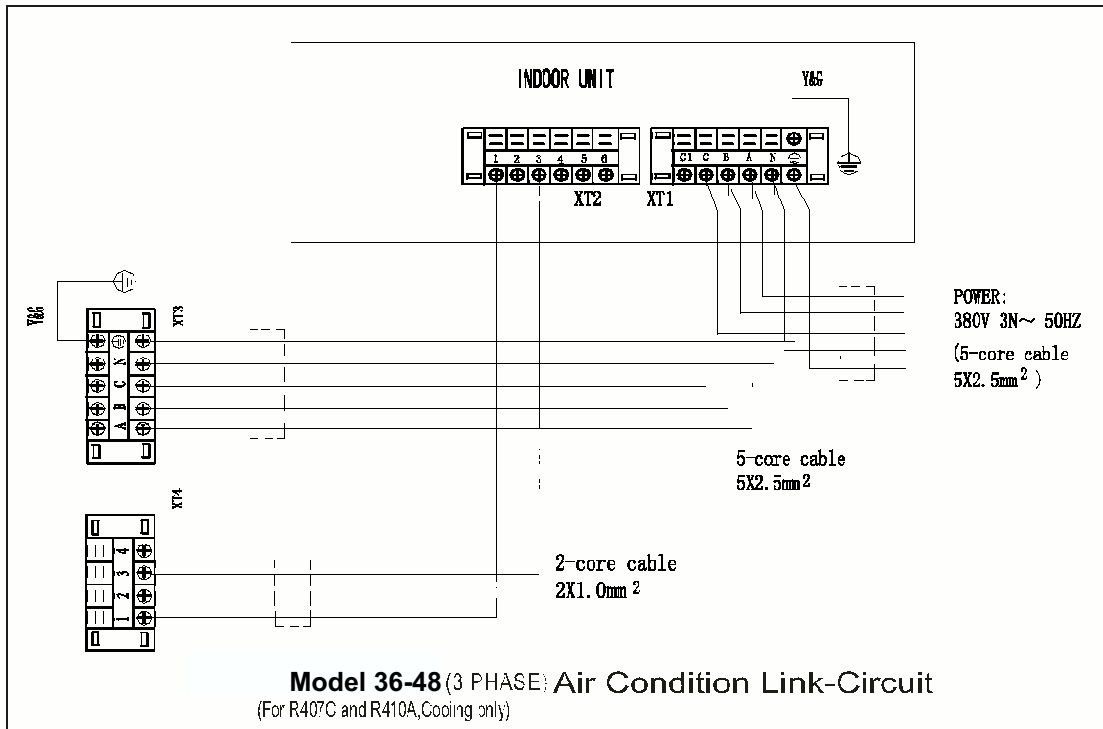

Chart 43

11. TEST OPERATION

1. The test operation must be carried out after the entire installation has been completed.
2. Please confirm the following points before the test operation:
 - The indoor unit and outdoor unit are installed properly.
 - Tubing and wiring are correctly completed.
 - The refrigerant pipe system is leakage-checked.
 - The drainage is unimpeded.
 - The heating insulation works well.
 - The ground wiring is connected correctly.
 - The length of the tubing and the added stow capacity of the refrigerant have been recorded.
 - The power voltage fits the rated voltage of the air conditioner.
 - There is no obstacle at the outlet and inlet of the outdoor and indoor units.
 - The gas-side and liquid-side stop valves are both opened.
 - The air conditioner is pre-heated by turning on the power.
3. According to the user's requirement, install the remote controller frame where the remote controller's signal can reach the indoor unit smoothly.
4. Test operation
 - Set the air conditioner under the mode of "COOLING" with the remote controller, and check the following points per the "Owner's Manual". If there is any malfunction, please resolve it as per chapter "Troubles And Cause" in the "Owner's Manual".
 - 1) The indoor unit
 - a. Whether the switch on the remote controller works well.
 - b. Whether the buttons on the remote controller works well.
 - c. Whether the air flow louver moves normally.
 - d. Whether the room temperature is adjusted well.
 - e. Whether the indicator lights normally.
 - f. Whether the temporary buttons works well.
 - g. Whether the drainage is normal.
 - h. Whether there is vibration or abnormal noise during operation.
 - i. Whether the air conditioner heats well in the case of the HEATING/COOLING type.
 - 2) The outdoor unit
 - a. Whether there is vibration or abnormal noise during operation.
 - b. Whether the generated wind, noise, or condensed of by the air conditioner have influenced your neighborhood.
 - c. Whether any of the refrigerant is leaked.

CAUTION

A protection feature prevents the air conditioner from being activated for approximately 3 minutes when it is restarted immediately after shut off.