

LENNOX®

APPLICATION GUIDE



PROVIDING **GLOBAL SYSTEM** SOLUTIONS

COMFAIR
Fan Coil Units

APPLICATION GUIDE

Ref: COMFAIR-AGU-0503-E

- Fan Coil Unit with centrifugal fan - Comfair HC
 - Description 2
 - Specifications 4
 - Dimensional drawings 7

- Fan Coil Unit with tangential fan - Comfair HT
 - Description 10
 - Specifications 12
 - Dimensional drawings 14

- High static pressure Fan Coil Unit - Comfair HH
 - Description 16
 - Specifications 18
 - Schémas dimensionnels 21

- Remote controls for HC, HT and HH 23

- Options and accessories for HC and HT 24

- Accessories for HH 26

- High-Wall Fan Coil Unit - Comfair HD 27



Ours products comply with the European standards and are Eurovent listed.



The specifications and technical characteristics in this booklet are given for information purposes. The manufacturer reserves the right to modify them without prior notice or obligation to modify in a similar manner, the equipments previously supplied.



CENTRIFUGAL FAN COIL UNITS HC



Comfair Fan Coil units are designed to minimum dimensions, in particular the depth is limited to only 200mm. The HC version is available in a range of 7 different versions and 9 models in each range, allowing all types of mounting arrangement and configurations, for example :

- Vertical Cased – on feet or plinth, with air inlet top or bottom and supply air vertical or front discharge
- Horizontal Cased – with air inlet from the back, front or via a plenum
- Vertical or horizontal chassis units

Vertical cased



Horizontal cased

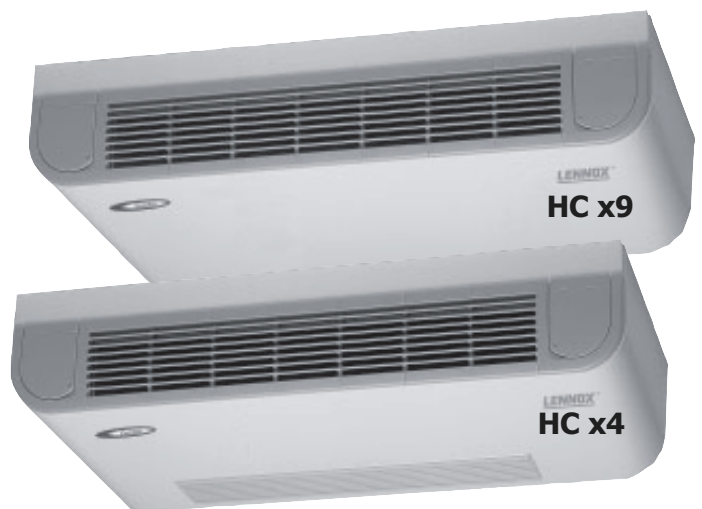

Chassis units



Standard units are complimented by a complete range of accessories and options, for example :

- auxiliary heating coil for 4 pipe operation
- control package with 3-way valves
- electric heating coil
- fresh air inlet with manual or motorised damper
- straight or 90° plenums for inlet or supply air (for chassis units only)
- decorative panel in metal or wood, pre-painted white (for chassis units only)

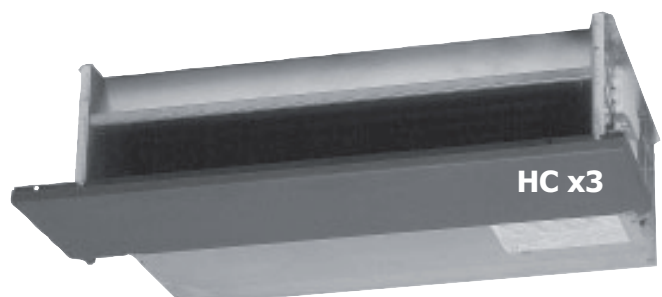



CHASSIS AND CASING

The chassis is constructed from galvanised sheet steel 0,8 mm. Mounting holes are provided on the back panel. Each unit, vertical or horizontal is equipped with a condensate drain pan which is insulated with thermal insulation 3mm thick, as are all parts of the chassis which come into contact with the treated air.

Of modern and elegant design, the casing is finished to the LENNOX standard colour of RAL 9002 white, however the full range of RAL colours are available upon special request.

Casing is also constructed from 0,8mm sheet steel, galvanised and epoxy painted and protected by a plastic contact film which can be removed after final installation. These methods ensure high resistance to Rust, corrosion and liquid and chemical agents.

Diffuser grilles are manufactured by plastic injection techniques and can be ordered as adjustable as an option.

The control panel is located beneath a concealed opening on the top of the unit, always on the opposite side to the valves.

COILS

Coils are from aluminium fins mechanically expanded onto copper tubes. Headers are equipped with easy accessible air vents. Coil connections are female antitorsion and as standard are located on the left side of the unit, but can be right side on request. The required connection side should always be clearly noted on the order.

Due to their high heating capacity even with reduced water temperatures COMFAIR HC model fan coil units are ideal for installations using solar energy or heat pumps.

Coils are pressure tested to 30 Bar.

FANS

Depending on the model, the HC units can contain 1, 2 or 3 double inlet centrifugal fans with aluminium blades, statically and dynamically balanced. The electric motor includes overload protection and has six standard speeds, three of which are pre-selected at the factory. Construction is in accordance with all relevant international standards, with a permanently connected capacitor. The motor assembly is mounted on rubber anti-vibration mounts and is directly coupled to the fan shafts which results in particularly quiet operation.

CONTROL PANEL

Easily accessible. It is located on the opposite side to the coils connections. As standard, the controller includes an electronic card, a 3-way switch (off / summer / winter) and a 3 speed fan switch. Factory fitted options include : Ambient temperature sensor (TA), and a minimum water temperature thermostat (TC). Horizontal units for concealed mounting are delivered with a terminal box for connecting to remote mounted controllers.

AIR FILTER

Simple to fit and remove, it is manufactured from a metal frame containing a washable poly-propylene filter medium class EU1. It is located on the suction side of the fan.

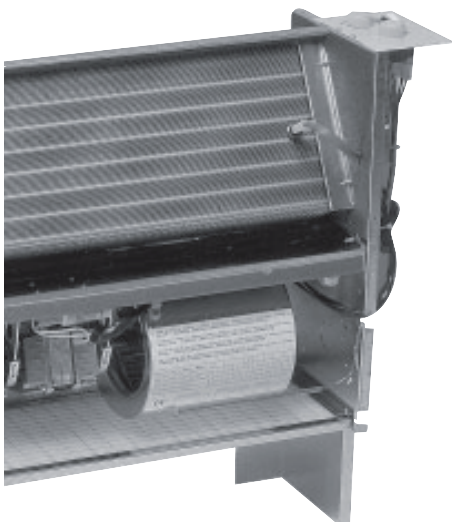

2 pipes system - 3 rows coil														
Model number		HC	10	20	30	40	50	60	70	80	90	100	110	120
Cooling capacity (A)	Sensible	Frig/h	636	880	1298	1868	1875	2291	2679	3414	4147	5227	6822	7309
		W	737	1021	1506	2167	2176	2658	3108	3960	4811	6064	7913	8478
	Total	Frig/h	746	1101	1787	2181	2682	3319	4041	4818	5930	6878	8635	9492
		W	865	1277	2072	2530	3111	3850	4687	5589	6879	7978	10017	11011
Heating capacity (B)		kcal/h	1074	1611	2229	2826	3152	3863	4424	5763	6991	8676	11276	12196
		W	1246	1869	2586	3279	3657	4481	5132	6685	8110	10064	13080	14147
Water flow		l/h	149	220	357	436	536	664	808	964	1186	1045	1364	1462
Water pressure drop	Cooling	mWG	0,08	0,2	0,6	0,88	1,62	2,6	5,6	2,8	4,31	2,66	1,71	2,68
		kPa	0,8	2	6	8,8	16,2	26	56	28	43,1	26,6	17,1	26,8
	Heating	mWG	0,07	0,17	0,51	0,75	1,38	2,21	4,76	2,38	3,66	2,38	1,16	2,22
		kPa	0,7	1,7	5,1	7,5	13,8	22,1	47,6	23,8	36,6	23,3	11,4	21,8
Heating capacity (C)		kcal/h	1831	2752	3732	4753	5242	6417	7303	9602	11630	14543	18979	20488
		W	2124	3192	4329	5513	6081	7444	8471	11138	13491	16870	22016	23766
Electrical heater		W	/	1000	1000	1000	2000	2000	2000	3000	3000	TBA	TBA	TBA
		A	/	4,55	4,55	4,55	9,1	9,1	9,1	13,65	13,65	TBA	TBA	TBA
Air flow		m ³ /h	227	289	404	453	575	685	708	1058	1242	1356	2012	2003
Sound power level (D)		dB(A)	46	44	44	47	47	52	52	58	64	62	66	66

4 pipes system - 3 and 1 rows coil														
Model number		HC	10	20	30	40	50	60	70	80	90	100	110	120
Cooling capacity (A)	Sensible	Frig/h	697	962	1458	1660	2146	2506	2884	3727	4532	5054	5529	7073
		W	809	1116	1691	1926	2490	2907	3345	4323	5257	5863	6413	8205
	Total	Frig/h	722	1064	1792	2048	2554	3173	3854	4597	5663	6650	7088	9186
		W	837	1234	2079	2376	2963	3680	4470	5333	6569	7714	8222	10656
Heating capacity (C)		kcal/h	1087	1633	2350	2489	3008	3561	4348	5339	6608	7231	7621	9856
		W	1261	1894	2726	2887	3489	4131	5044	6193	7665	8388	8840	11433
Water flow	Cooling	(A) l/h	144	213	358	410	511	635	771	919	1133	1330	1418	1837
	Heating	(C) l/h	109	163	235	249	301	356	435	534	661	739	79	1008
Water pressure drop	Cooling	mWG	0,08	0,2	0,57	0,82	1,45	2,3	5	2,4	3,8	2,54	1,09	2,56
		kPa	0,8	2	5,7	8,2	14,5	23	50	24	38	24,9	10,7	25,1
	Heating	mWG	0,03	0,07	0,17	0,2	0,34	0,42	0,75	1,39	2,17	1,76	2,16	3,47
		kPa	0,3	0,7	1,7	2	3,4	4,2	7,5	13,9	21,7	17,2	21,2	34
Air flow		m ³ /h	216	275	384	430	546	651	673	1005	1180	1291	1502	1908
Sound power level (D)		dB(A)	47	47	44	48	46	53	53	59	65	63	61	66

Nominal conditions			
Maximum fan speed - Unit air discharge unducted (ESP = 0 Pa)			
Cooling (A)	Heating (B)	Heating (C)	Sound power level (D):
Inlet water temperature: 7 °C	Inlet water temperature: 50 °C	Inlet water temperature: 70 °C	ISO 23741 standard
Outlet water temperature: 12 °C	Same water flow as in cooling mode	Outlet water temperature: 60 °C	
Inlet air temperature : 27 °C D.B - 19 °C W.B	Inlet air temperature: 20 °C	Inlet air temperature: 20 °C	

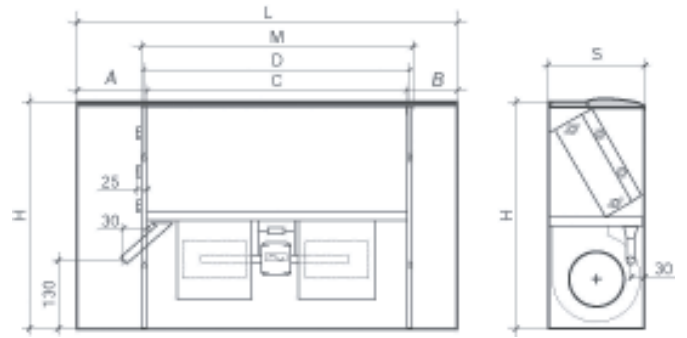
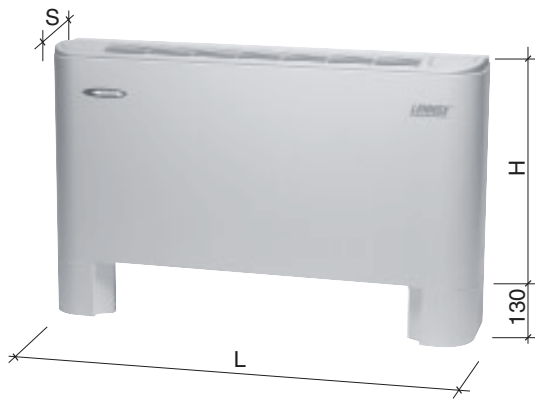

Dimensions and connections														
Model number	HC	10	20	30	40	50	60	70	80	90	100	110	120	
Fans	Nb	1	1	2	2	2	2	2	2	2	3	3	3	
Standard coil	Rows	Nb	3	3	3	3	3	3	3	3	3	3	3	
	Connections	F	3/4"	3/4"	3/4"	3/4"	3/4"	3/4"	3/4"	3/4"	3/4"	3/4"	3/4"	
Auxiliary coil	Rows	Nb	1	1	1	1	1	1	1	1	1	1	1	
	Connections	F	1/2"	1/2"	1/2"	1/2"	1/2"	1/2"	1/2"	1/2"	1/2"	1/2"	1/2"	
Drain connection	F mm	20	20	20	20	20	20	20	20	20	20	20	20	
Height	mm	480	480	480	480	480	480	585	585	585	602	602	602	
Length	mm	660	860	1060	1060	1260	1260	1260	1460	1460	1660	1960	1960	
Width	mm	220	220	220	220	220	220	220	220	220	256	256	256	
	M	mm	420	620	820	820	1020	1020	1020	1220	1220	1380	1680	1680
	A	mm	180	180	180	180	180	180	180	180	180	220	220	220
	B	mm	110	110	110	110	110	110	110	110	110	108	108	108
	C	mm	370	570	770	770	970	970	970	1170	1170	1330	1630	1630
	D	mm	395	595	795	795	995	995	995	1195	1195	1355	1655	1655
Net weight	kg	14	17	22	23	27	28	30	35	36	46	55	57	

Available static pressure														
Model number	HC	10	20	30	40	50	60	70	80	90	100	110	120	
2 pipes system	Pa	1	9	12	7	9	19 low	12	15	41 low	33 low	43	37 low	47
	Pa	2	11 low	15 low	10 low	11 low	22	16 low	19	51 med	41	49 min	47	58 min
	Pa	3	15	19 med	15 med	17 med	28 med	22	26 low	55 max	45 med	62 med	68 med	74
	Pa	4	18 med	25 max	19 max	22	32 max	28 med	34 med	60	49	68	76 max	80 med
	Pa	5	25 max	32	25	27 max	40	36 max	44 max	65	53 max	75 max	84	84 max
	Pa	6	32	40	32	37	49	45	54	70	60	84	/	/
4 pipes system	Pa	1	8	10	6	8	14 low	10	11	30 low	27 low	43	37 min	47
	Pa	2	9 low	12 low	8 low	9 low	17	13 low	15	38 med	33	48 min	47	58 min
	Pa	3	11	15 med	13 med	14 med	21 med	18	20 low	42 max	37 med	61 med	67 med	73
	Pa	4	15 med	19 max	15 max	17	25 max	22 med	28 med	50	40	67	75 max	79 med
	Pa	5	19 max	25	19	22 max	32	28 max	36 max	55	44 max	74 max	83	85 max
	Pa	6	25	32	24	30	38	35	44	60	51	82	/	/

Maximum motor power input													
Model number	HC	10	20	30	40	50	60	70	80	90	100	110	120
Power input	W	38	54	60	61	99	99	97	210	207	213	277	273
Nominal current	A	0,18	0,25	0,28	0,28	0,45	0,45	0,45	0,96	0,95	0,97	1,27	1,25

Standard power supply: 230 V / 1 / 50 Hz

The data indicated by low, med, max correspond to the standard factory set fan speeds.

Sound power level (D)														
Model number	HC	10	20	30	40	50	60	70	80	90	100	110	120	
2 pipes system	dB(A)	1	32	32	30	30	37 low	39	36	51 low	51 low	52	47	49
	dB(A)	2	33 low	36 low	33 low	33 low	39	40 low	38	56 med	55	55 min	50	51 min
	dB(A)	3	37	40 med	40 med	40 med	43 med	43	42 low	58 max	58 med	57 med	58 min	59
	dB(A)	4	41 med	44 max	44 max	44	47 max	47 med	46 med	61	61	60	61 med	61 med
	dB(A)	5	46 max	49	47	47 max	51	52 max	52 max	64	64 max	63 max	67 max	66 max
	dB(A)	6	51	53	51	50	56	56	57	67	67	65	/	/
4 pipes system	dB(A)	1	32	34	30	30	35 low	38	36	51 low	51 low	53	48	49
	dB(A)	2	34 low	38 low	34 low	35 low	38	41 low	39	57 med	56	55 min	51	52 min
	dB(A)	3	38	43 med	40 med	42 med	42 med	44	43 low	59 max	59 med	58 med	58 min	60
	dB(A)	4	42 med	47 max	44 max	45	46 max	48 med	47 med	62	62	61	62 med	62 med
	dB(A)	5	47 max	52	47	48 max	51	53 max	53 max	65	65 max	63 max	67 max	67 max
	dB(A)	6	52	56	50	52	56	57	58	68	68	66	/	/

Correction factor													
Model number	HC	10	20	30	40	50	60	70	80	90	100	110	120
Sensible cooling capacity	1	0,65	0,72	0,60	0,53	0,69 low	0,60	0,54	0,79 low	0,68 low	0,73	0,55	0,56
	2	0,69 low	0,79 low	0,68 low	0,60 low	0,78	0,69 low	0,63	0,91 med	0,78	0,78 min	0,6	0,63 min
	3	0,78	0,88 med	0,89 med	0,79 med	0,89 med	0,78	0,73 low	1 max	0,85 med	0,86 med	0,77 min	0,79
	4	0,88 med	1 max	1 max	0,89	1 max	0,87 med	0,85 med	1,09	0,92	0,93	0,85 med	0,85 med
	5	1 max	1,14	1,11	1 max	1,14	1 max	1 max	1,18	1 max	1 max	1 max	1 max
	6	1,13	1,35	1,24	1,13	1,29	1,14	1,17	1,30	1,09	1,09	/	/
Total cooling capacity	1	0,73	0,78	0,60	0,52	0,71 low	0,63	0,56	0,80 low	0,70 low	0,71	0,53	0,54
	2	0,77 low	0,84 low	0,67 low	0,60 low	0,80	0,71 low	0,65	0,93 med	0,80	0,76 min	0,58	0,6 min
	3	0,84	0,92 med	0,89 med	0,80 med	0,90 med	0,80	0,75 low	1 max	0,86 med	0,85 med	0,75 min	0,78
	4	0,92 med	1 max	1 max	0,90	1 max	0,88 med	0,86 med	1,09	0,93	0,92	0,84 med	0,84 med
	5	1 max	1,10	1,11	1 max	1,12	1 max	1 max	1,17	1 max	1 max	1 max	1 max
	6	1,08	1,32	1,23	1,12	1,26	1,13	1,16	1,28	1,09	1,09	/	/
Heating capacity	1	0,64	0,71	0,63	0,56	0,70 low	0,62	0,54	0,80 low	0,69 low	0,72	0,54	0,55
	2	0,68 low	0,78 low	0,72 low	0,64 low	0,79	0,70 low	0,63	0,92 med	0,80	0,77 min	0,59	0,61 min
	3	0,78	0,88 med	0,90 med	0,81 med	0,89 med	0,79	0,74 low	1 max	0,86 med	0,85 med	0,76 min	0,78
	4	0,88 med	1 max	1 max	0,90	1 max	0,88 med	0,85 med	1,07	0,93	0,92	0,84 med	0,84 med
	5	1 max	1,12	1,08	1 max	1,10	1 max	1 max	1,13	1 max	1 max	1 max	1 max
	6	1,11	1,22	1,17	1,10	1,21	1,10	1,13	1,22	1,07	1,08	/	/
Air flow	1	0,54	0,64	0,56	0,50	0,63 low	0,54	0,50	0,74 low	0,62 low	0,65	0,44	0,46
	2	0,6 low	0,72 low	0,67 low	0,58 low	0,73	0,63 low	0,58	0,90 med	0,74	0,71 min	0,49	0,53 min
	3	0,70	0,84 med	0,87 med	0,76 med	0,86 med	0,73	0,69 low	1 max	0,82 med	0,81 med	0,68 min	0,71
	4	0,83 med	1 max	1 max	0,88	1 max	0,84 med	0,82 med	1,13	0,91	0,9	0,78 med	0,79 med
	5	1 max	1,21	1,14	1 max	1,19	1 max	1 max	1,25	1 max	1 max	1 max	1 max
	6	1,22	1,42	1,32	1,17	1,41	1,19	1,22	1,43	1,14	1,11	/	/



TANGENTIAL FAN COIL UNITS HT



Comfair Fan Coil units are designed to minimum dimensions, in particular the depth is limited to only 200mm. The HT version is available in a range of 5 different versions and 5 models in each range, allowing all types of mounting arrangement and configurations, for example :

- Vertical Cased – on feet or plinth, with air inlet front or bottom and supply air vertical or front discharge
- Vertical chassis units with supply air top or front

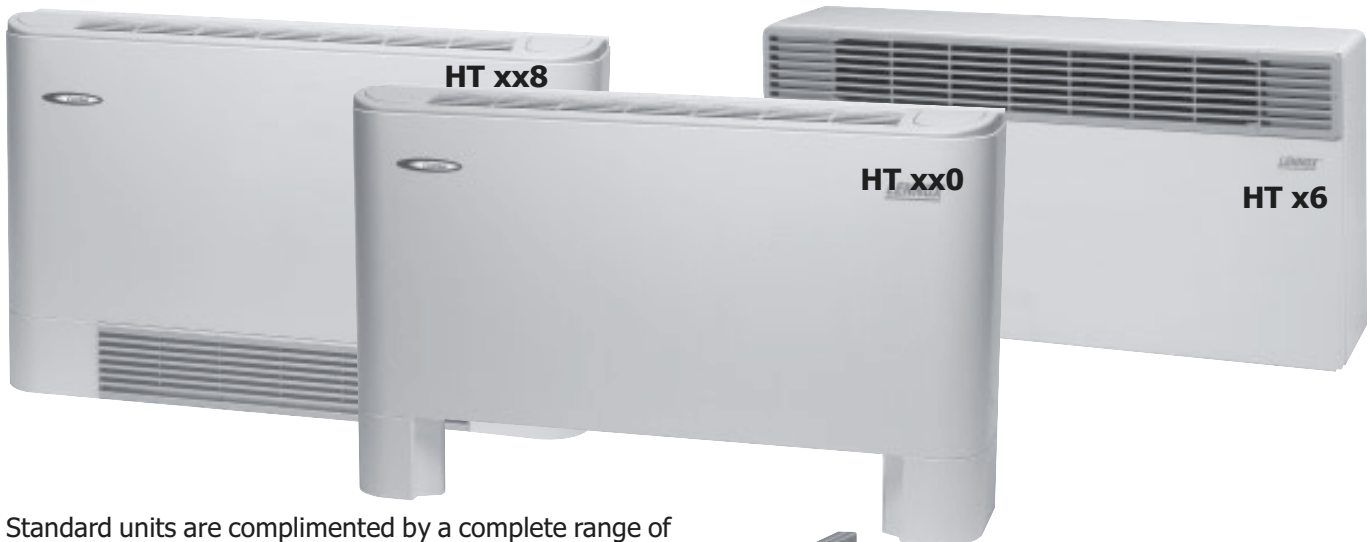

Standard units are complimented by a complete range of accessories and options, for example :

- auxiliary heating coil for 4 pipe operation
- control package with 3-way valves
- electric heating coil
- Fresh air inlet with manual or motorised damper
- straight or 90° plenums for inlet or supply air (for chassis units only)
- decorative panel in metal or wood, pre-painted white (for chassis units only)

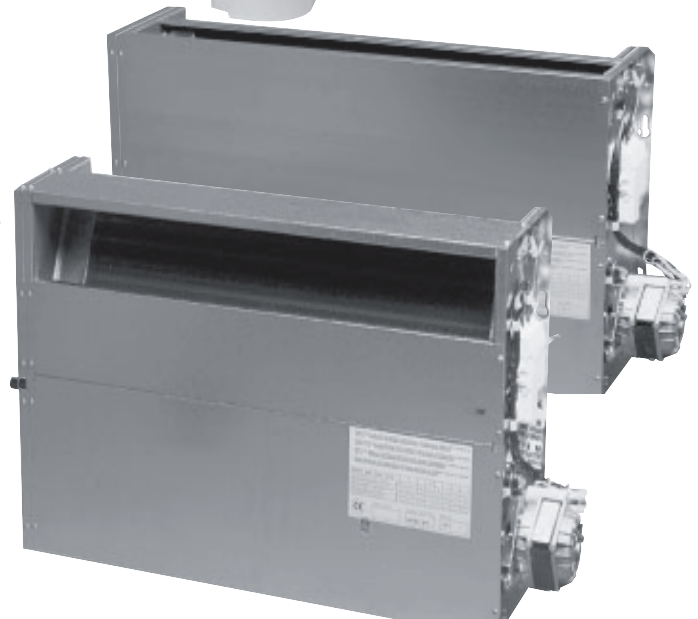

FANS

By using a Tangential Fan, the Comfair HT units are almost silent in operation. The fan is constructed from aluminium blades in the form of a spiral, specially designed to give higher air volumes at lower speed.

In order to reduce the possibility of vibration being transmitted through the chassis of the unit, the fan assembly is mounted on rubber anti-vibration mounts and the motor is directly coupled to the fan shaft. Precise balancing of the complete assembly of every unit guarantees a reduction in noise level of more than 20%.



CHASSIS AND CASING

The chassis is constructed from galvanised sheet steel 0,8 mm. Mounting holes are provided on the back panel. Each unit is equipped with a condensate drain pan which is insulated with thermal insulation 3mm thick, as are all parts of the chassis which come into contact with the treated air.

Of modern and elegant design, at home or in the office, the HT unit blends in to any environment. Standard finish is in the LENNOX standard colour of RAL 9002 white, however the full range of RAL colours are available upon special request.

Casing is also constructed from 0,8mm sheet steel, galvanised and epoxy painted and protected by a plastic contact film which can be removed after final installation. These methods ensure high resistance to Rust, corrosion and liquid and chemical agents.

Diffuser grilles are manufactured by plastic injection techniques and have a fixed air distribution pattern.

The control panel is located beneath a concealed opening on the top right hand side of the unit.

COILS (Connection side left only)

Coils are from aluminium fins mechanically expanded onto copper tubes. Headers are equipped with easy accessible air vents. Coil connections are female antitorion and are always located on the left side of the unit.

Due to their high heating capacity even with reduced water temperatures COMFAIR HC model fan coil units are ideal for installations using solar energy or heat pumps.

Coils are pressure tested to 30 Bar.



CONTROL PANEL

Easily accessible. It is always located on the right side of the unit.

As standard, the controller includes an electronic card, a 3-way switch (off / summer / winter) and a 3 speed fan switch. Factory fitted options include : Ambient temperature sensor (TA), and a minimum water temperature thermostat (TC). Vertical units for concealed mounting are delivered with a terminal box for connecting to remote mounted controllers (CD1, CD2/X1, CD3/V ...).

AIR FILTER

Simple to fit and remove, it is manufactured from a metal frame containing a washable poly-propylene filter medium class EU1. It is located on the suction side of the fan.

2 pipes system - 3 rows coil							
Model number		HT	100	200	300	400	600
Cooling capacity (A)	Sensible	Frig/h	640	790	1 330	1 740	2 220
		W	750	920	1 540	2 020	2 590
	Total	Frig/h	670	890	1 680	2 290	2 890
		W	780	1 040	1 950	2 660	3 360
Heating capacity (B)		kcal/h	1 030	1 290	2 080	2 640	3 390
		W	1 190	1 510	2 420	3 070	3 940
Water flow		l/h	135	179	337	458	579
Water pressure drop	Cooling	mWG	0,4	0,3	1	2,2	1,8
		kPa	4	3	10	22	18
	Heating	mWG	0,4	0,3	0,9	1,9	1,6
		kPa	4	3	9	19	16
Heating capacity (C)		kcal/h	1 770	2 210	3 480	4 380	5 640
		W	2 050	2 570	4 050	5 100	6 560
Electrical heater		W	1 000	1 000	1 000	2 000	3 000
Air flow		m ³ /h	233	267	405	494	645
Sound power level (D)		dB(A)	47	47	48	50	51

4 pipes system - 3 and 1 rows coil							
Model number		HT	100	200	300	400	600
Cooling capacity (A)	Sensible	Frig/h	590	690	1 070	1 500	1 920
		W	690	810	1 250	1 740	2 230
	Total	Frig/h	620	790	1 360	2 000	2 530
		W	720	920	1 590	2 330	2 940
Heating capacity (C)		kcal/h	1 290	1 400	2 130	2 710	3 490
		W	1 500	1 620	2 480	3 150	4 060
Water flow	Cooling	(A) l/h	125	158	273	401	506
	Heating	(C) l/h	129	140	213	272	350
Water pressure drop	Cooling	mWG	0,3	0,2	0,7	1,6	1,3
		kPa	3	2	7	16	13
	Heating	mWG	0,3	0,4	0,9	1,8	3,6
		kPa	3	4	9	18	36
Air flow		m ³ /h	221	253	384	469	612
Sound power level (D)		dB(A)	49	49	50	52	53

Nominal conditions			
Maximum fan speed - Unit air discharge unducted (ESP = 0 Pa)			
Cooling (A)	Heating (B)	Heating (C)	Sound power level (D):
Inlet water temperature: 7 °C	Inlet water temperature: 50 °C	Inlet water temperature: 70 °C	ISO 23741 standard
Outlet water temperature: 12 °C	Same water flow as in cooling mode	Outlet water temperature: 60 °C	
Inlet air temperature : 27 °C D.B - 19 °C W.B	Inlet air temperature: 20 °C	Inlet air temperature: 20 °C	

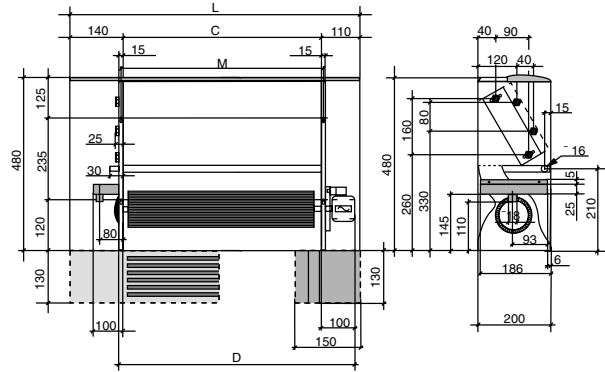
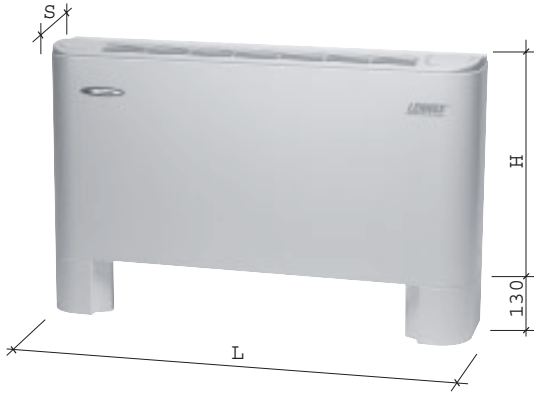

Dimensions and connections							
Model number		HT	100	200	300	400	600
Fans		Nb	1	1	1	1	1
Standard coil	Rows	Nb	2	3	3	3	3
	Connections	Φ	1/2"	1/2"	1/2"	1/2"	1/2"
Auxiliary coil	Rows	Nb	1	1	1	1	1
	Connections	Φ	1/2"	1/2"	1/2"	1/2"	1/2"
Height	H	mm	480	480	480	480	480
Length	L	mm	760	760	960	1 160	1 360
Width	S	mm	200	200	200	200	200
	M	mm	535	535	735	935	1 135
	C	mm	510	510	710	910	1 110
	D	mm	635	635	835	1 035	1 235
Net weight		kg	15	16	21	26	30

Maximum motor power input							
Model number		HT	100	200	300	400	600
Power input		W	29	29	36	39	50
Nominal current		A	0,14	0,14	0,17	0,17	0,23

Sound power level (D)							
Model number		HT	100	200	300	400	600
2 pipes system	med	dB(A)	39	39	41	43	45
	low	dB(A)	33	33	34	35	37
4 pipes system	med	dB(A)	40	40	42	44	46
	low	dB(A)	35	35	36	37	39

Corretion factor							
Model number		HT	100	200	300	400	600
Sensible cooling capacity	Min		0,56	0,52	0,54	0,53	0,54
	Moy		0,74	0,74	0,71	0,76	0,76
Total cooling capacity	Min		0,61	0,57	0,54	0,54	0,55
	Moy		0,81	0,81	0,7	0,78	0,78
Heating capacity	Min		0,55	0,51	0,53	0,54	0,53
	Moy		0,72	0,72	0,74	0,77	0,77
Air flow	Min		0,64	0,67	0,69	0,72	0,73
	Moy		0,64	0,67	0,69	0,72	0,73

Standard power supply: 230 V / 1 / 50 Hz

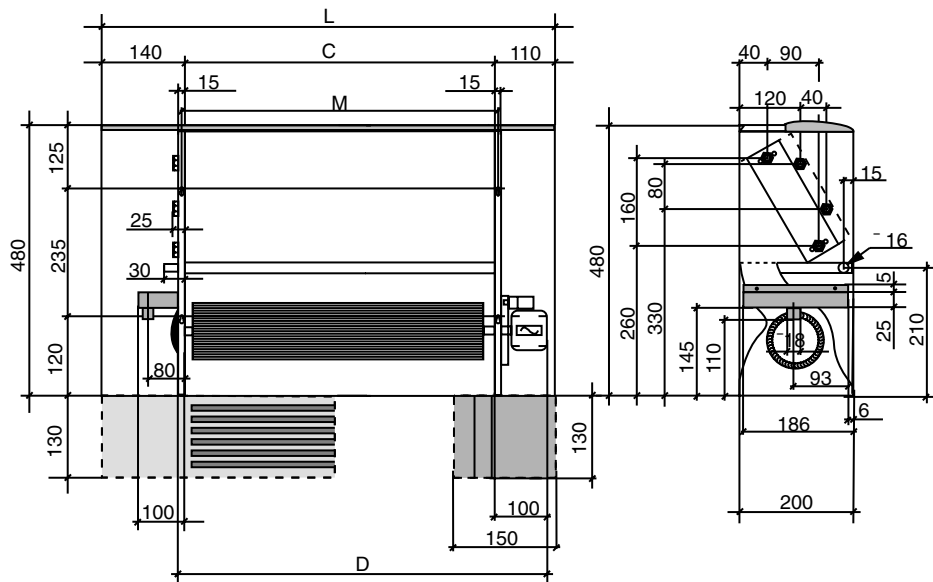

**HT 100 to HT 600
HT 108 to HT 608**



HT 106 to HT 606

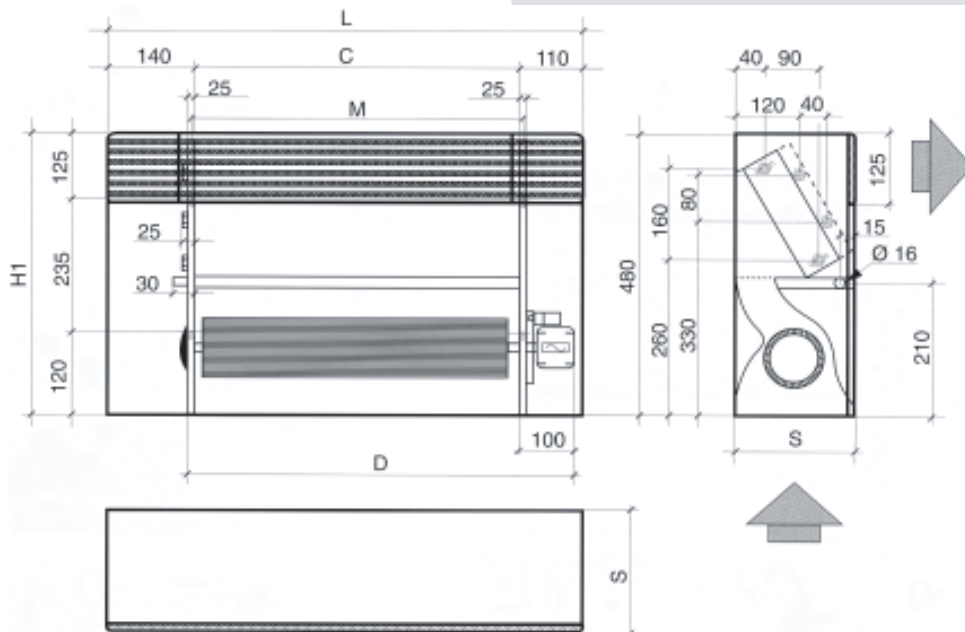

Model number	HT 100	HT 200	HT 300	HT 400	HT 600
H1	480	480	480	480	480
L	760	760	960	1 160	1 360
S	200	200	200	200	200
M	535	535	735	935	1 135
C	510	510	710	910	1 110
D	635	635	835	1 035	1 235

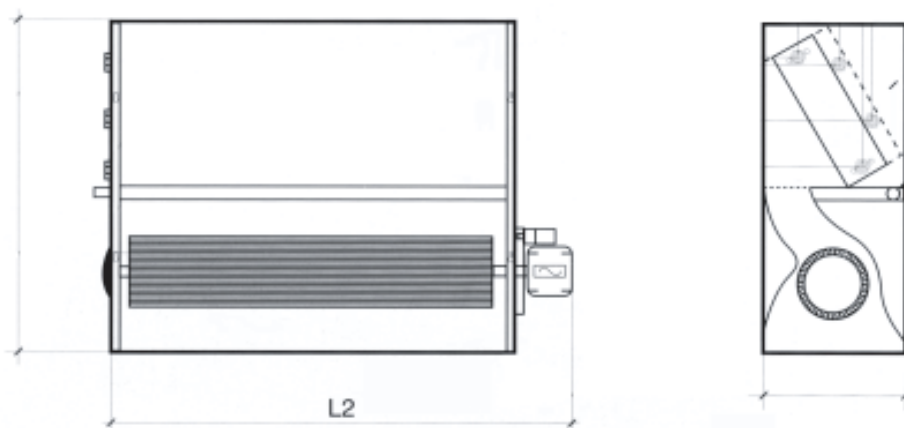

HT 102 to HT 602



HT 107 to HT 607

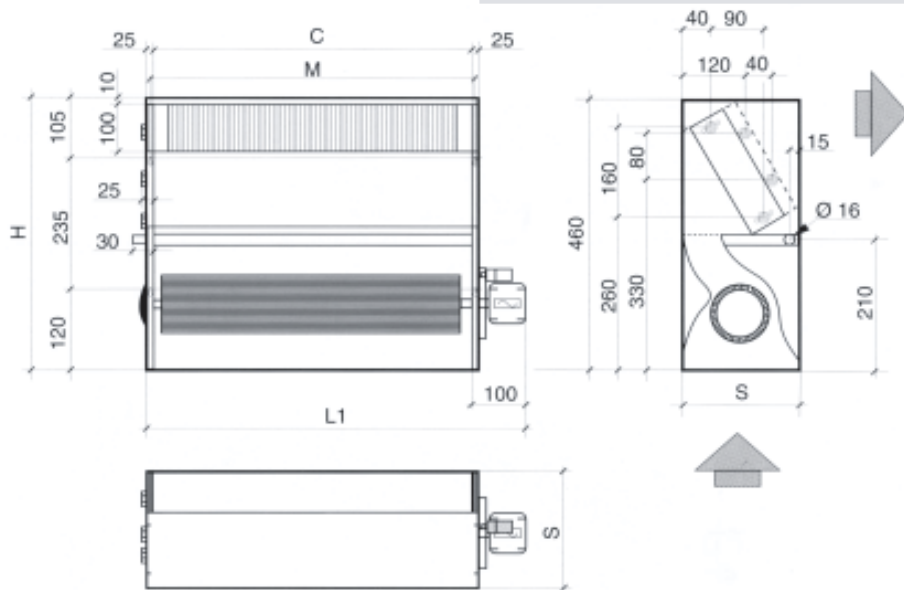

Model number	HT 100	HT 200	HT 300	HT 400	HT 600
H - H2	460	460	460	460	460
L1 - L2	635	635	835	1 035	1 235
S	200	200	200	200	200
M	535	535	735	935	1 135
C	510	510	710	910	1 110
D	635	635	835	1 035	1 235



HIGH PRESSURE FAN COIL UNITS HH



Comfair HH fan coil units are designed to operate against higher external static pressures (from 105 to 260 Pa), and are available in 7 sizes.

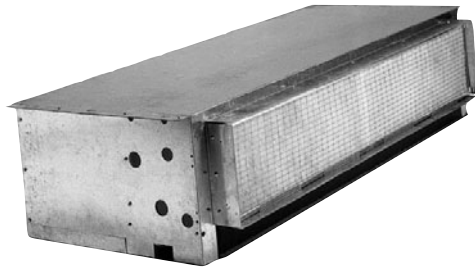

All standard units can be supplied with a complete range of factory or site fitted accessories, allowing a multitude of configurations for all typical applications, for example:

- auxiliary condensate drain pan (UTC)
- air Filter section (SFA)
- auxiliary Coil
- fresh air inlet damper (SSP)
- electric heater (SRE)
- inlet, supply and exhaust air plenums (PAM, RAM et BAM)

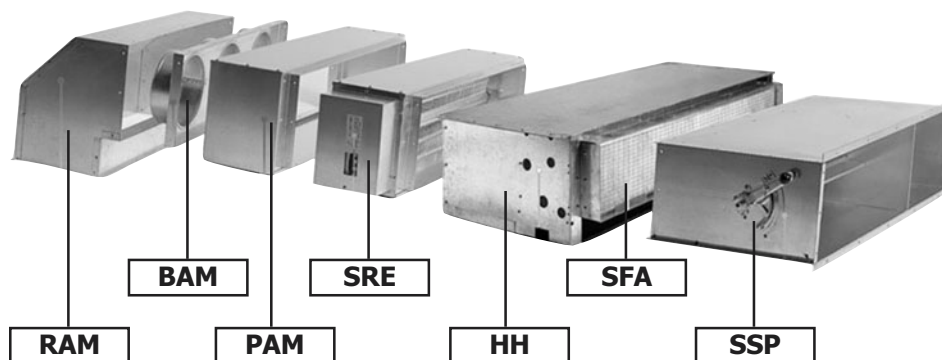

FAN SECTION

Composed of one or two double inlet centrifugal fans with aluminium blades, mounted in horizontal position and statically and dynamically balanced. The electric motor is fitted with overload protection and has three speeds. It is constructed to comply with all relevant International standards, with a capacitor permanently in circuit. Motors are connected directly to the fan shafts and are located on anti-vibration mounts to ensure particularly quiet operation.

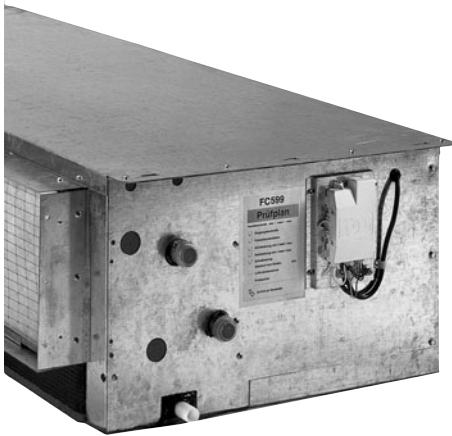

CHASSIS

The chassis is manufactured from thick (1mm) galvanised sheet steel.

COILS

Water Heat exchangers are copper tubes with aluminium fins, bonded to the tubes by a mechanical expansion process. Coil connections are of female type antitorsion and headers are fitted with easily accessible air-vents.

CONTROL PANEL

Comfair HH fan coil units must be controlled from a separate remote controller. A large selection of controllers with varying levels of function is available to satisfy most requests.

Options delivered separately : Ambient Thermostats (TA), Minimum water temperature thermostat (TC), Remote (wall mounted) controllers (CD1, CD2/X1, ...).

AIR FILTER

Simple to remove, it comprises a metal frame containing a washable acrylic filter media (filtration efficiency EU 2).

MANUAL FRESH AIR INLET DAMPER

Produced from Alu-Zinc sheet metal, it allows the introduction of fresh air up to a maximum of 30% of the total air volume.

ELECTRIC HEATER

Electric heater elements meet all of the relevant International safety standards and are fitted as standard with a safety cut-out thermostat and automatic reset. Heater elements are factory fitted with all electrical wiring and are connected to the control panel via a contactor.



AUXILIARY COIL

In order to offer the best solutions for 4 pipe applications, a supplementary 1 row coil can be ordered factory fitted.

INLET, SUPPLY AND EXHAUST AIR PLENUMS

Penums are constructed from galvanised sheet steel allow for easy connection to ductwork.

2 pipes system - 3 rows coil									
Model number		HH	10	20	30	40	50	60	70
Cooling capacity (A)	Sensible	Frig/h	2800	4861	6346	7437	9503	18219	34055
		W	3248	5639	7361	8627	11023	21134	39504
	Total	Frig/h	3455	6074	7930	9137	11285	23976	43653
		W	4008	7046	9198	10599	13091	27812	50638
Heating capacity (B)		kcal/h	4286	7338	9664	11034	14498	27957	51820
		W	1972	8512	11210	12800	16818	32430	60111
Water flow		l/h	691	1215	1586	1827	2257	4795	8731
Water pressure drop	Cooling	mWG	2	3,1	3,4	3,2	3,6	3,4	4
		kPa	20	31	34	32	36	34	40
	Heating	mWG	1,7	2,7	2,9	2,8	3,1	2,9	3,4
		kPa	17	27	29	28	31	29	34
Heating capacity (C)		kcal/h	7171	12239	16134	18404	24355	46448	86264
		W	8318	14197	18716	21349	28252	53880	100066
Electrical heater	Standard	W	3000	6000	6000	9000	9000	12000	18000
	High	W	4500	9000	9000	12000	12000	18000	24000
Air flow		m ³ /h	837	1423	1951	2131	3002	4678	9250
Sound power level (D)		dB(A)	68	69	70	69	74	78	81

4 pipes system - 3 and 1 rows coil									
Model number		HH	10	20	30	40	50	60	70
Cooling capacity (A)	Sensible	Frig/h	2677	4598	6079	6914	9107	17404	32580
		W	3105	5333	7051	8020	10564	20189	37793
	Total	Frig/h	3107	5473	7143	8229	10568	21542	39278
		W	3604	6348	8286	9545	12258	24989	45563
Heating capacity (C)		kcal/h	3607	6031	7890	9086	12057	33475	60514
		W	4184	6996	9152	10540	13986	38831	70196
Water flow	Cooling	(A) l/h	621	1095	1429	1646	2114	4308	7856
	Heating	(C) l/h	361	603	789	909	1206	3348	6051
Water pressure drop	Cooling	mWG	1,6	2,4	2,8	2,5	3,1	2,7	3,2
		kPa	16	24	28	25	31	27	32
	Heating	mWG	2,7	2,3	3,6	2,1	3,4	3,3	3,6
		kPa	27	23	36	21	34	33	36
Air flow		m ³ /h	795	1352	1853	2024	2852	4444	8788
Sound power level (D)		dB(A)	68	69	70	70	73	78	81

Nominal conditions			
Maximum fan speed - Unit air discharge unducted (ESP = 0 Pa)			
Cooling (A)	Heating (B)	Heating (C)	Sound power level (D):
Inlet water temperature: 7 °C	Inlet water temperature: 50 °C	Inlet water temperature: 70 °C	ISO 23741 standard
Outlet water temperature: 12 °C	Same water flow as in cooling mode	Outlet water temperature: 60 °C	
Inlet air temperature : 27 °C D.B - 19 °C W.B	Inlet air temperature: 20 °C	Inlet air temperature: 20 °C	

Modelnumber		Sound power level (D)							
		HH	10	20	30	40	50	60	70
2 pipes system	dB(A)	Min	63	58	61	58	62	69	71
	dB(A)	Moy	67	65	68	65	69	73	76
	dB(A)	Max	68	69	70	69	74	78	81
4 pipes system	dB(A)	Min	63	58	61	61	61	69	71
	dB(A)	Moy	67	65	68	68	68	73	76
	dB(A)	Max	68	69	70	70	73	78	81

Taille		Correction factor							
		HH	10	20	30	40	50	60	70
Sensible cooling capacity	Low	0,86	0,71	0,76	0,71	0,65	0,74	0,76	
	Med	0,94	0,89	0,94	0,91	0,85	0,87	0,89	
	Max	1	1	1	1	1	1	1	
Total cooling capacity	Low	0,87	0,73	0,78	0,73	0,68	0,76	0,78	
	Med	0,95	0,90	0,94	0,93	0,86	0,89	0,9	
	Max	1	1	1	1	1	1	1	
Heating capacity	Low	0,86	0,72	0,77	0,72	0,67	0,75	0,77	
	Med	0,95	0,9	0,94	0,92	0,86	0,88	0,89	
	Max	1	1	1	1	1	1	1	
Air flow	Low	0,81	0,63	0,69	0,63	0,56	0,69	0,7	
	Med	0,93	0,85	0,91	0,89	0,80	0,84	0,85	
	Max	1	1	1	1	1	1	1	

HH 10 à HH 50

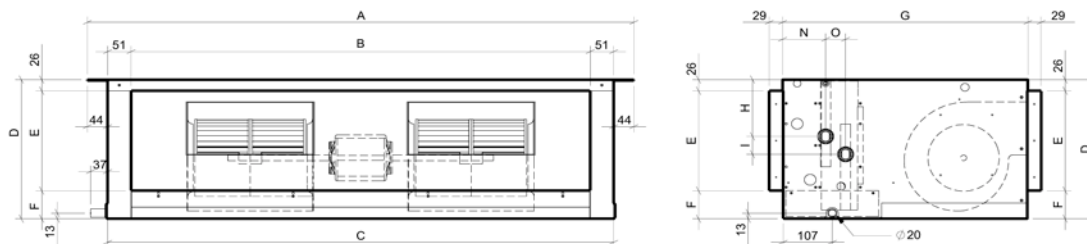

HH 60 et HH 70

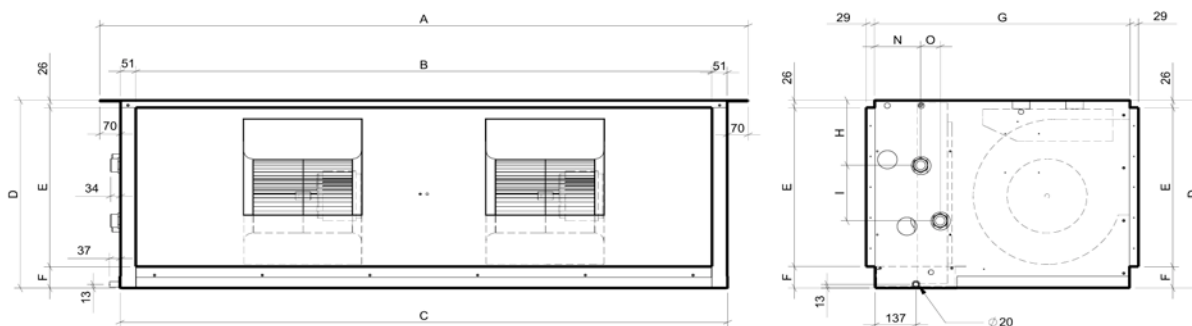

Model number	HH	10	20	30	40	50	60	70
A	mm	738	1 088	1 188	1 428	1 428	1 481	2 168
B	mm	548	898	998	1 238	1 238	1 239	1 926
C	mm	650	1 000	1 100	1 340	1 340	1 341	2 028
D	mm	299	299	323	323	373	674	674
E	mm	232	232	232	232	272	573	573
F	mm	41	41	65	65	75	75	75
G	mm	533	533	533	533	533	852	852
H	mm	96	96	107	107	133	235	235
I	mm	100	100	100	100	100	200	200
N	mm	105	105	105	105	105	156	156
O	mm	65	65	65	65	65	65	65

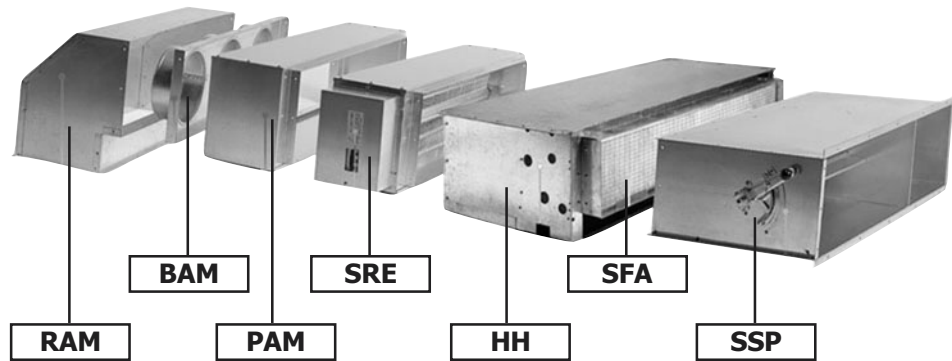
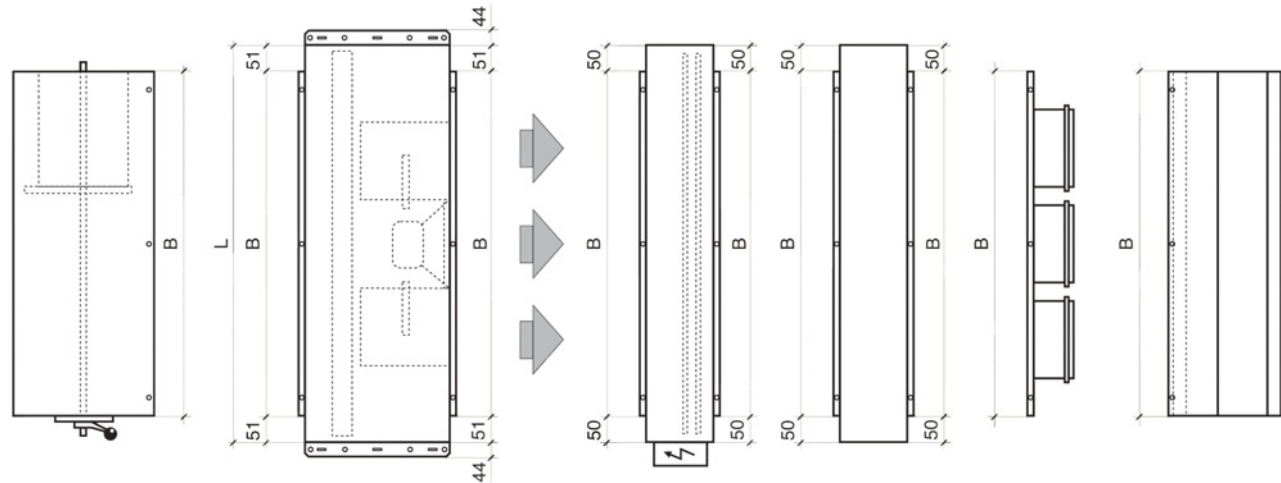
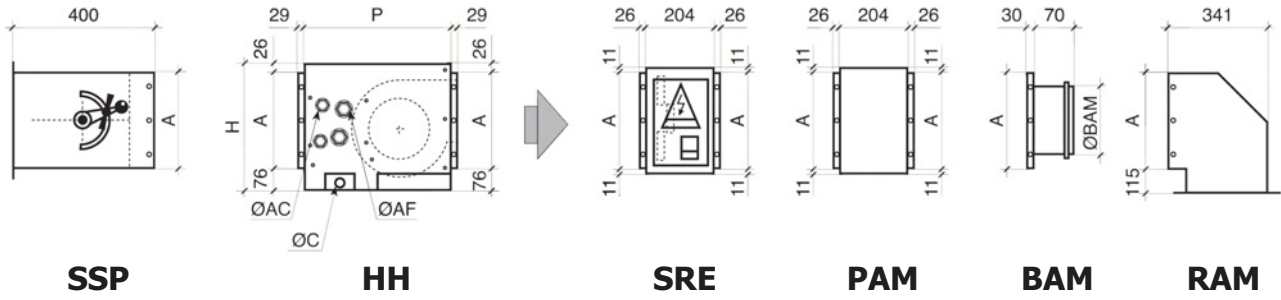

Model number	HH	10	20	30	40	50	60	70
H	mm	299	299	324	324	374	674	674
P	mm	533	533	533	533	533	583	853
L	mm	650	1 000	1 100	1 339	1 339	1 341	2 028
A	mm	197	197	222	222	272	572	572
B	mm	548	898	998	1 237	1 237	1 239	1 926
Nb x ØBAM	mm	2 x F200	3 x F200	4 x F200	5 x F200	6 x F200	7 x F200	8 x F200
ØAF	Ø	1/2"	1/2"	3/4"	3/4"	1"	1" 1/4	1" 1/2
ØAC	Ø	1/2"	1/2"	1/2"	1/2"	3/4"	1"	1" 1/4
ØC	mm	20	20	20	20	20	20	20



Ambient temperature sensor (220)
Off/Summer/Winter - **TA/1**



Off/Summer/Winter + temperature
set point - **TA/2**



Remote controller (220)
Off/Summer/Winter
+ 3fan speed - **CD1**

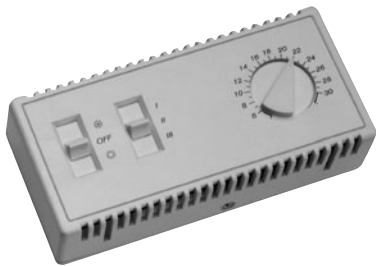

Off/Summer/Winter + 3fan speed
+ electronic thermostat
(control for 1 valve) - **CD2/X1**



Off/Summer/Winter + 3 fan speed
+ electronic thermostat
(control for 2 valves) - **CD2/X2**

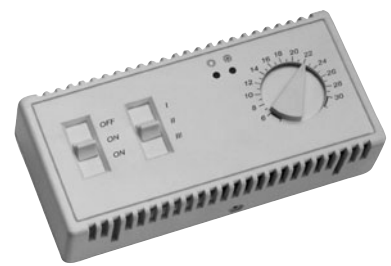

Remote controller (220)
Off/Summer/Winter
+ 3 fan speed + electronic
thermostat with dead zone
Summer/Winter - **CD2/ZN**

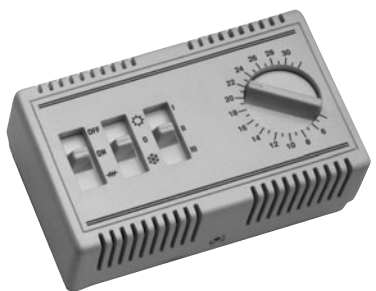

Remote controller (220)
Off/Summer/Winter + 3 speed fan
+ electronic thermostat - **CDR**



Remote controller (220)
Off/Summer/Winter + electronic
thermostat + automatic 3 speed fan
control + temperature set point
controller - **CD3/V**

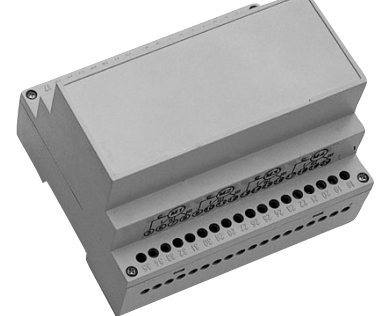

Interface card for the control
of up to 4 units - **SDI**

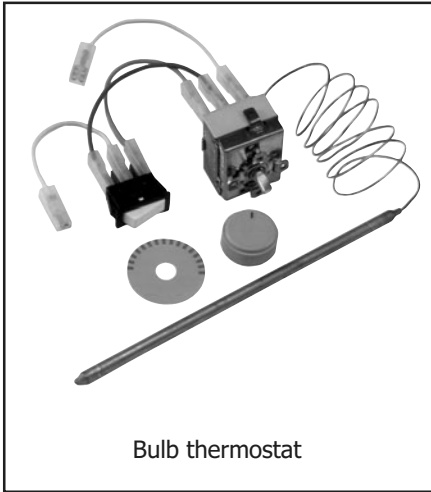

Bulb thermostat

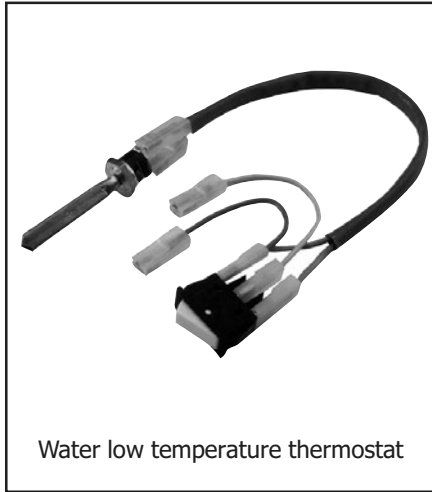

Water low temperature thermostat



Auxiliary drain pan (also available for horizontal versions)

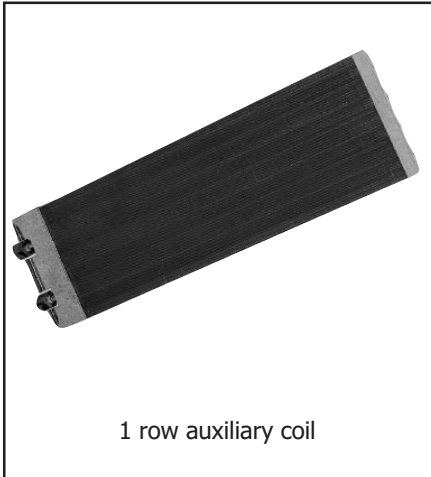

1 row auxiliary coil

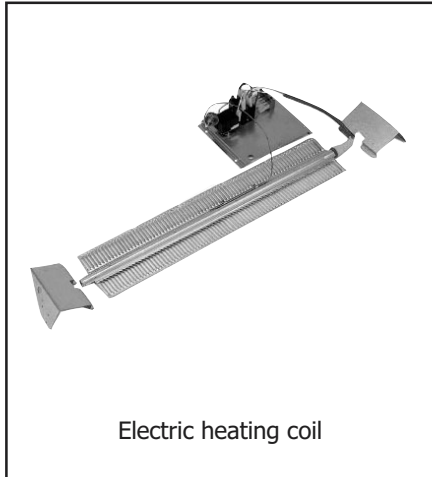

Electric heating coil

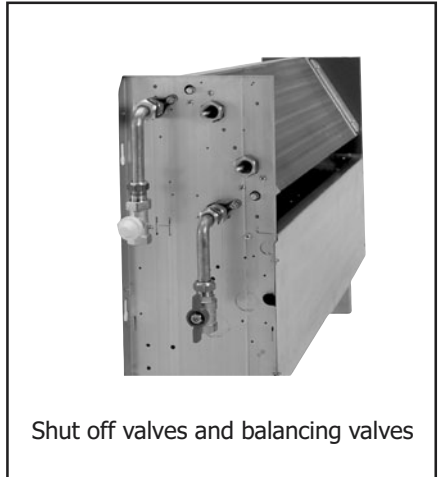

Shut off valves and balancing valves

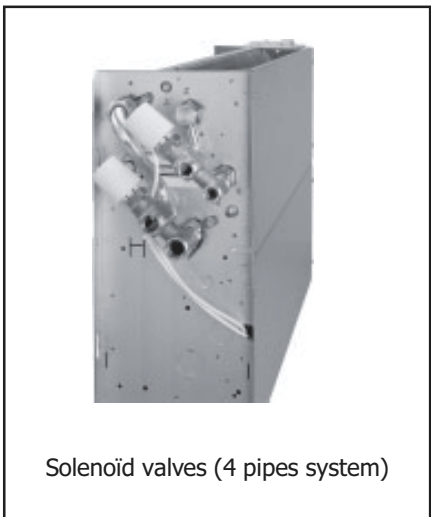

Solenoid valves (4 pipes system)

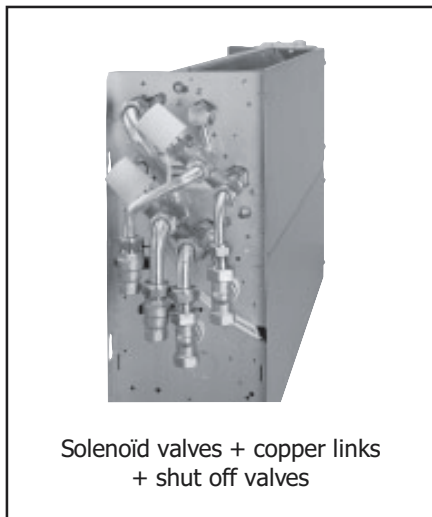

Solenoid valves + copper links + shut off valves

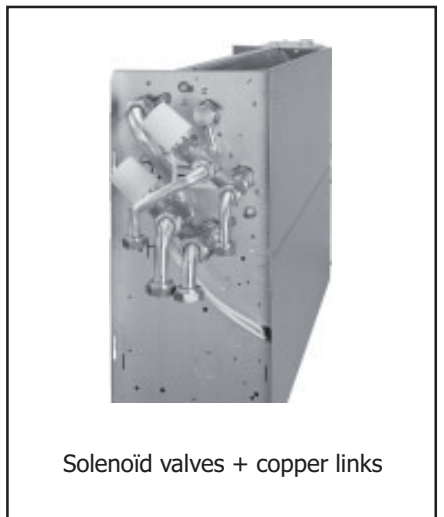

Solenoid valves + copper links



Supply plenum with circular spigots

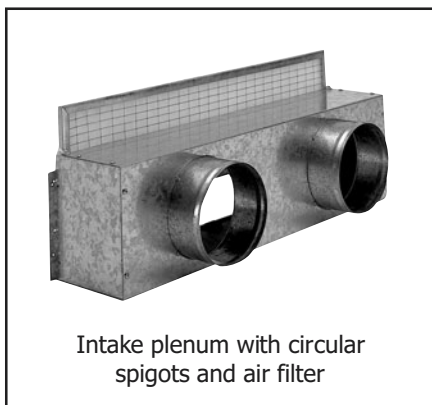

Intake plenum with circular spigots and air filter

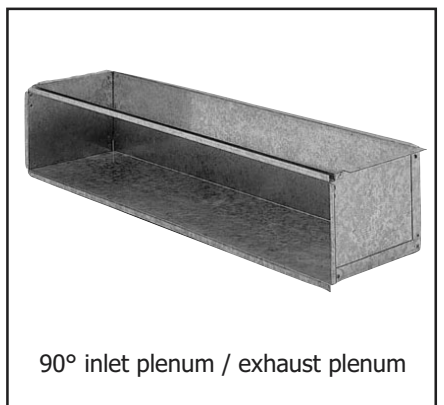

90° inlet plenum / exhaust plenum

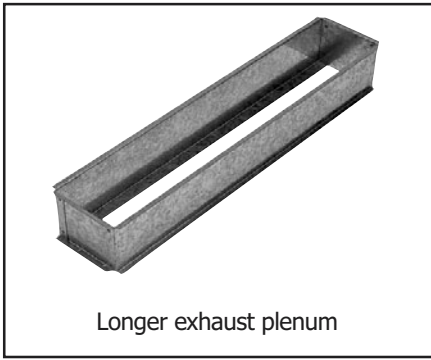

Longer exhaust plenum

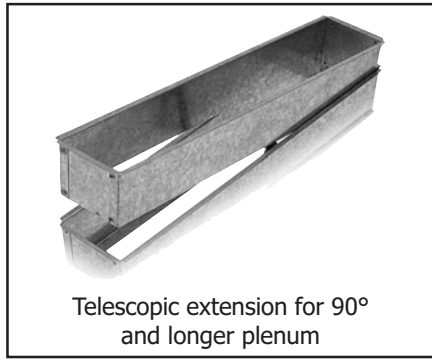

Telescopic extension for 90° and longer plenum

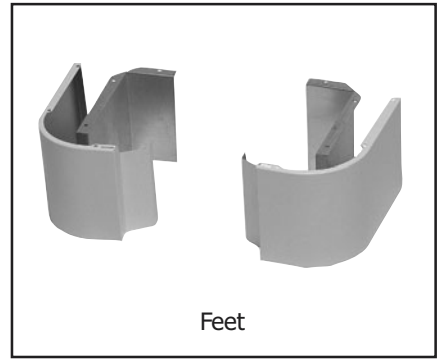

Feet



Decorative panel in metal or wood, pre-painted white

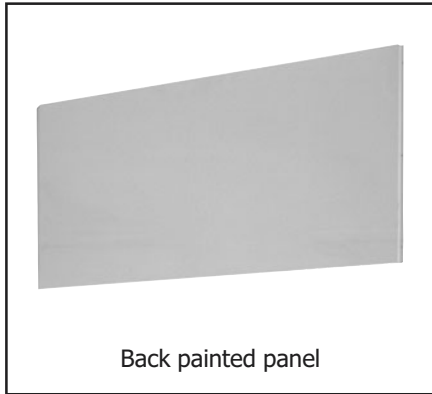

Back painted panel

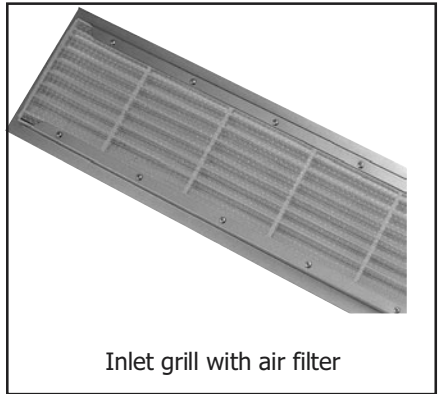

Inlet grill with air filter

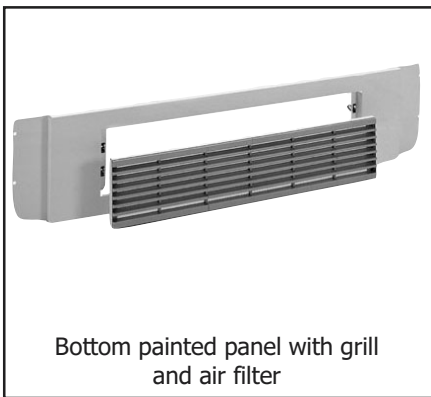

Bottom painted panel with grill and air filter



Bottom painted panel without grill

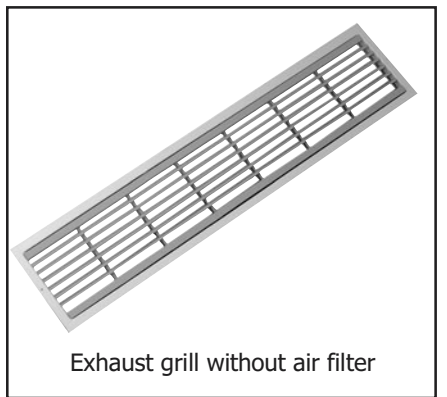

Exhaust grill without air filter

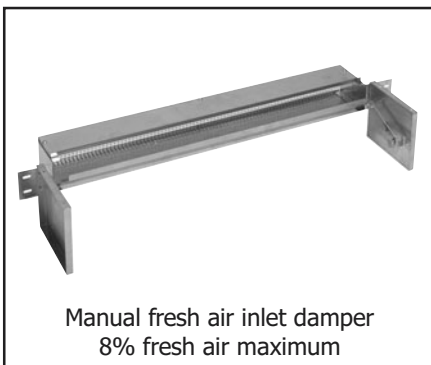

Manual fresh air inlet damper 8% fresh air maximum

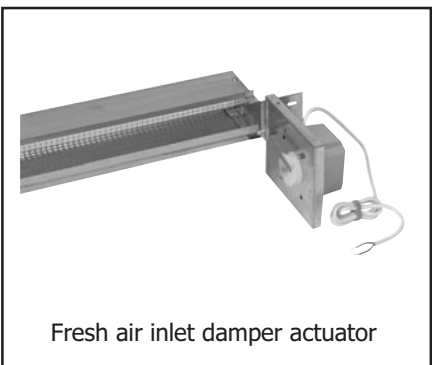

Fresh air inlet damper actuator



Adjustable diffuser grilles



Air filter section - **SFA**

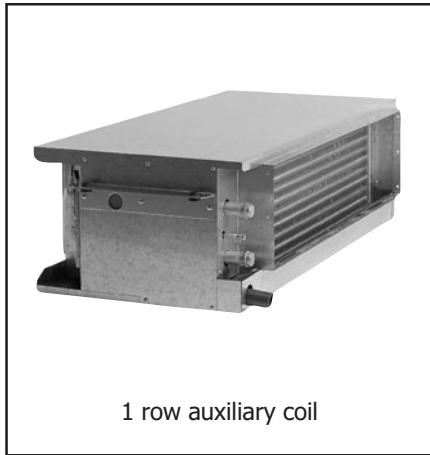

1 row auxiliary coil

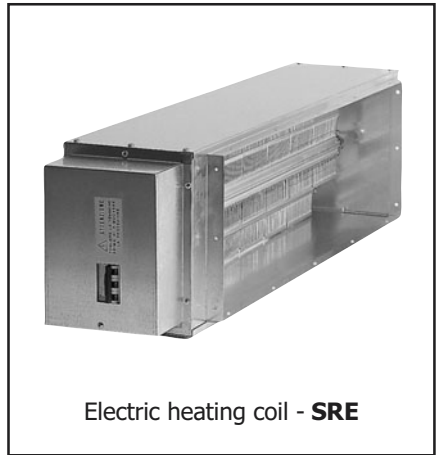

Electric heating coil - **SRE**



Manual fresh air inlet damper
33% maximum fresh air - **SSP**

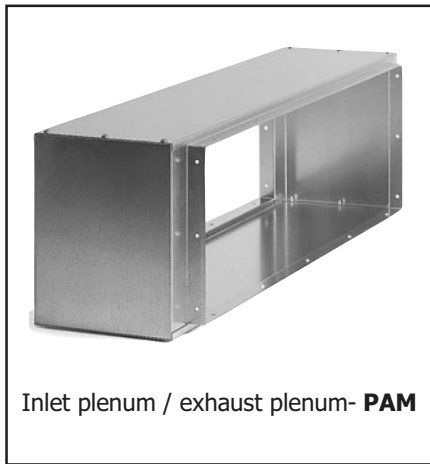

Inlet plenum / exhaust plenum- **PAM**

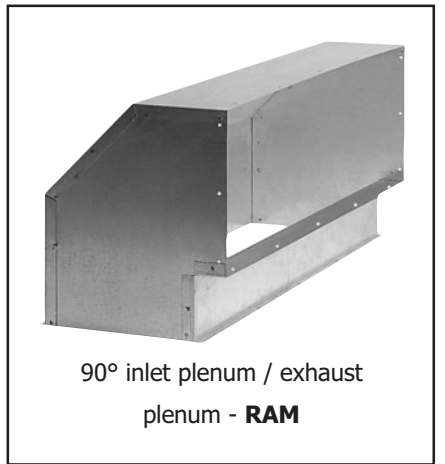

90° inlet plenum / exhaust
plenum - **RAM**

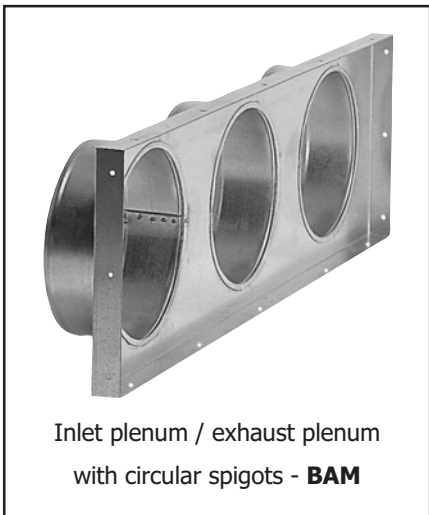

Inlet plenum / exhaust plenum
with circular spigots - **BAM**



HIGH WALL FAN COIL UNITS HD



Comfair HD fan coil units are similar in design and use to the widely used DX high-wall mini-split systems. With a maximum width of only 210mm, the casing is manufactured from high quality plastic and is of an aesthetically pleasing design to compliment almost every environment.



«A BREATH OF FRESH AIR»

The fan is of a Tangential type running at low speed to guarantee low noise levels. The concept of air discharge from the unit allows efficient distribution of the treated air for maximum comfort, and simplicity of use. HD units are equipped with a system of automatic horizontal air deflection through an arc of 35° in cooling operation (10° in heating operation), which avoids stratification of the airstreams. When the unit stops, the deflector blades close automatically, which serves not only to protect the internal components against dust but also preserves the neat aesthetic appearance of the unit.



FILTRATION AND AIR QUALITY

The Comfair HD units not only control the temperature of the air but also the air quality in the conditioned space. Each unit is fitted with a filter and an Ioniser which produces negatively charged ions which attracts the positively charged dust particles and neutralises harmful microbes present in the atmosphere. The Ioniser comprises of a small generator, which transmits an intermittent high voltage to carbon fibres situated in the airstream.

COILS

Each unit contains a chilled and hot water coil manufactured from copper tubes with aluminium fins. Water connections are female gas 1/2" and each coil is fitted with an air vent. A water temperature sensor prevents low temperature discharge.

REMOTE CONTROLLER

The infra-red remote controller offers the same functions as a DX split system. It includes an LCD display which indicates the status and set points of the unit. Sixteen buttons allow fast and easy control of the operation of all functions of the unit.

DIMENSIONS

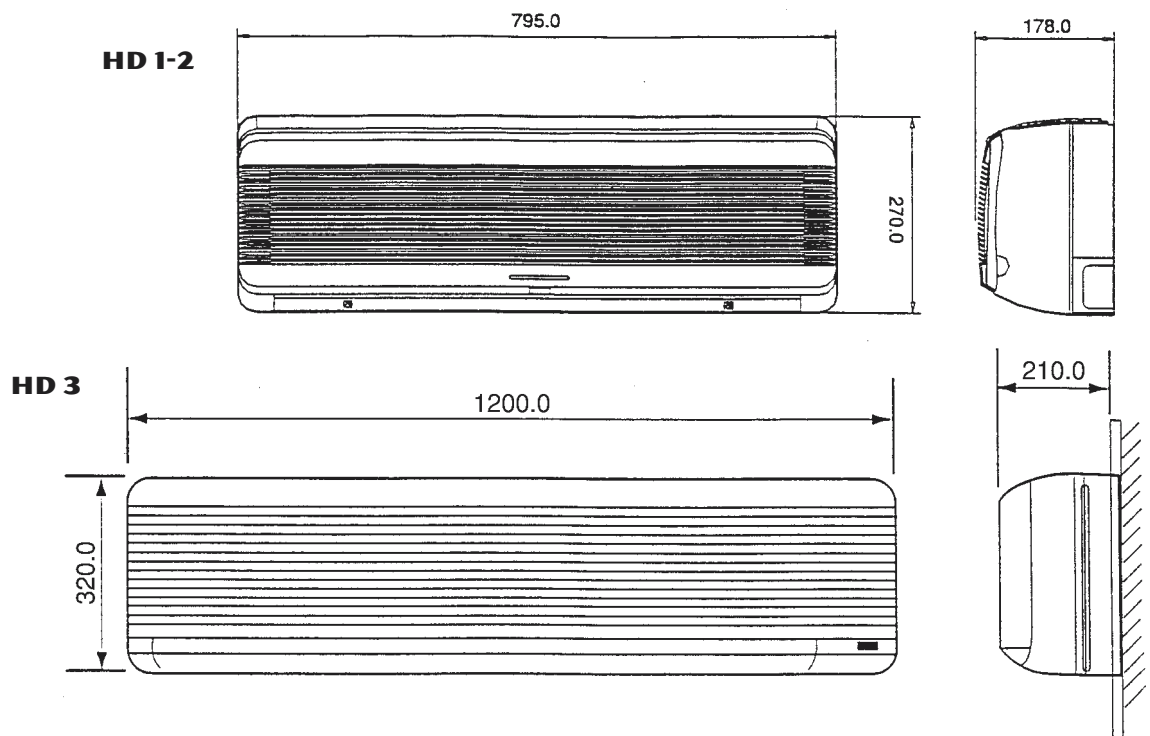

		General data			
Model number		HD	1	2	3
Cooling capacity (A)	Sensible	Frig/h	1 462	1 711	2 958
		W	1 700	1 990	3 440
	Total	Frig/h	1 754	2 115	3 800
		W	2 040	2 460	4 420
Heating capacity (B)		kcal/h	2 365	2 855	4 850
		W	2 750	3 320	5 640
Water flow		l/h	351	423	760
Water pressure drop	Cooling	mCE	1,8	2	5
		kPa	18	20	50
	Heating	mCE	1,6	1,7	4,3
		kPa	16	17	43
Heating capacity (C)		kcal/h	4 000	4 824	8 144
		W	4 650	5 610	9 470
Air flow		m ³ /h	440	433	860
Sound power level (D)		dB(A)	54	54	61
Power input		W	29	29	58
Nominal current		A	0,13	0,13	0,27

		Weight			
Model number		HD	1	2	3
Net weight		kg	8	9	13

		Sound power level (D)			
Model number		HD	1	2	3
Sound level (D)	Moy	dB(A)	42	46	50
	Min	dB(A)	48	50	57

		Correction factor			
Model number		HD	1	2	3
Sensible cooling capacity	Min		0,68	0,52	0,54
	Moy		0,84	0,74	0,71
Total cooling capacity	Min		0,71	0,57	0,54
	Moy		0,85	0,81	0,7
Heating capacity	Min		0,7	0,51	0,53
	Moy		0,86	0,72	0,74
Air flow	Min		0,61	0,47	0,49
	Moy		0,76	0,67	0,69

Nominal conditions			
Maximum fan speed - Unit air discharge unducted (ESP = 0 Pa)			
Cooling (A)	Heating (B)	Heating (C)	Sound power level (D):
Inlet water temperature: 7 °C	Inlet water temperature: 50 °C	Inlet water temperature: 70 °C	ISO 23741 standard
Outlet water temperature: 12 °C	Same water flow as in cooling mode	Outlet water temperature: 60 °C	
Inlet air temperature : 27 °C D.B - 19 °C W.B	Inlet air temperature : 20 °C	Inlet air temperature : 20 °C	

REMOTE CONTROL

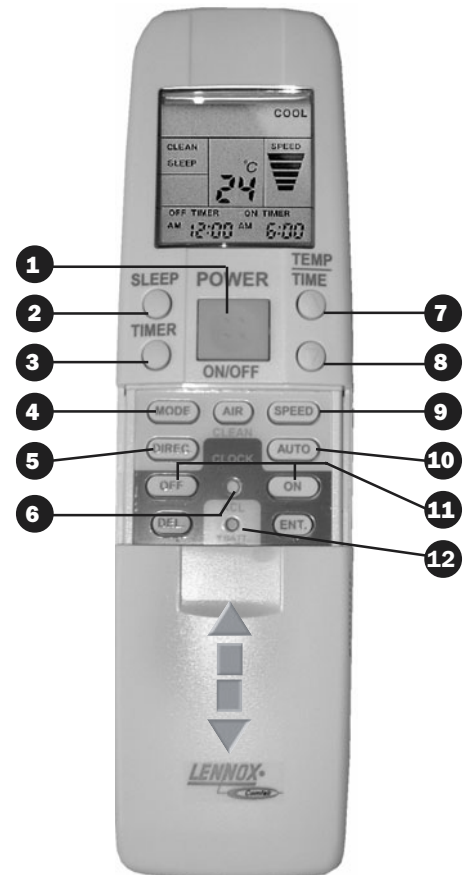

- 1 On / Off
- 2 Stand-By
- 3 Time clock for delayed start from 1-9 hours
- 4 Function mode
 - Automatic
 - Cooling
 - De-humidification
 - Ventilation
 - Heating
- 5 Discharge position (5 positions plus automatic mode)
 - Automatic
 - Low
 - Medium
 - High
- 6 Timed operation
- 7 Increase set-point
- 8 Lower set-point
- 9 Fan speed
- 10 Ioniser On /Off
- 11 Timed operation (start and stop)
- 12 Reset

GERMANY : **LENNOX DEUTSCHLAND GmbH**
Tel : + 49 69 42 09 79 0
Fax : + 49 69 42 09 79 40
e-mail : info.de@lennoxdeutschland.com

**BELGIUM,
LUXEMBOURG :** **LENNOX BENELUX N.V./S.A.**
Tel : + 32 3 633 30 45
Fax : + 32 3 633 00 89
e-mail : info.be@lennoxbenelux.com

SPAIN : **LENNOX REFAC S.A.**
Tel : + 34 915 40 18 10
Fax : + 34 915 42 84 04
e-mail : marketing@lennox-refac.com

FRANCE : **LENNOX FRANCE**
Tel : + 33 1 64 76 23 23
Fax : + 33 1 64 76 35 75
e-mail : marketing.france@lennoxfrance.com

**UNITED KINGDOM,
IRELAND :** **LENNOX INDUSTRIES Ltd**
Tel : + 44 1604 599400
Fax : + 44 1604 594200
e-mail : ukmarketing@lennoxind.com

NETHERLANDS : **LENNOX BENELUX B.V.**
Tel : + 31 33 2471 800
Fax : + 31 33 2459 220
e-mail : info@lennoxbenelux.com

POLAND : **LENNOX POLSKA Sp. z o. o.**
Tel : + 48 22 832 26 61
fax : + 48 22 832 26 62
e-mail : info@lennoxpolska.pl

PORTUGAL : **LENNOX PORTUGAL Lda.**
Tel : + 351 22 998 33 70
Fax : + 351 22 998 33 79
e-mail : info@lennoxportugal.com

CZECH REPUBLIC : **LENNOX JANKA a.s.**
Tel : + 420 2 510 88 111
Fax : + 420 2 579 10 393
e-mail : janka@janka.cz

RUSSIA : **LENNOX DISTRIBUTION MOSCOW**
Tel : + 7 095 246 07 46
Fax : + 7 502 933 29 55
e-mail : lennox.dist.moscow@mtu-net.ru

SLOVAKIA : **LENNOXSLOVENSKO s.r.o.**
Tel : + 421 7 44 87 19 27
Fax : + 421 7 44 88 64 72
e-mail : lennox.slovensko@lennox.sk

UKRAINE : **LENNOX DISTRIBUTION KIEV**
Tel : + 380 44 219 23 23
Fax : + 380 44 213 14 21
e-mail : jankauk@uct.kiev.ua

**OTHER EUROPEAN COUNTRIES,
AFRICA,
MIDDLE-EAST :** **LENNOX DISTRIBUTION**
Tel : + 33 4 72 23 20 14
Fax : + 33 4 72 23 20 28
e-mail : marketing@lennoxdist.com



LENNOX®

www.lennox europe.com