



Application guide Installation, operating and maintenance manual **AIRCUBE - KSCM/KSHM**



- Providing indoor climate comfort



Congratulations you have made a wise choice and we feel sure that it will meet your expectations

WARNING: Read this manual before installation, and repair or maintenance work.

CONTENTS	PAGE
. GENERAL DESCRIPTION	2
. DENOMINATION	3
. PRODUCT RANGE UNITS COOLING ONLY	3
. PRODUCT RANGE UNITS HEAT PUMP	3
. PHYSICAL DATA	4
. ELECTRICAL DATA	4
. FAN PERFORMANCES	4
. TECHNICAL DATA	5
. COOLING CAPACITIES	6-7
. HEATING CAPACITIES	8-9
. COOLING PIPING DRAWINGS	10-12
. HEATING PIPING DRAWINGS	13-15
. UNIT DIMENSIONS	16
. UNIT INSTALLATION	17
. PIPE CONNECTIONS	18-20
. ELECTRICAL CONNECTIONS	21
. OPTIONS	22-23
. COMMISSIONING AND OPERATION	24
. MAINTENANCE	25-27

Lennox have been providing environmental solutions since 1895, our range of AIRCUBE continues to meet the standards that have made LENNOX a household name. Flexible design solutions to meet YOUR needs and uncompromising attention to detail. Engineered to last, simple to maintain and Quality that comes as standard. Information on local contacts at www.lennox europe.com.

All the technical and technological information contained in this manual, including any drawing and technical descriptions provided by us, remain the property of Lennox and must not be utilised (except in the operation of this product), reproduced, issued to or made available to third parties without the prior written agreement of Lennox.

GENERAL DESCRIPTION

The AIRCUBE range of condensing units, cooling only and heat pump, is of the “air to air” type, and designed for commercial / industrial applications.

They are designed for outdoor installation, with a wide range of options to suit the customer requirements when being matched to other types of indoor units or Air Handling equipment.

CABINET

Made from galvanised steel sheet with an epoxy paint finish, to ensure good weatherproofing and a high resistance to corrosion. (RAL 9002 standard).

The units are constructed with metal base sections to support the weight of the units during handling and transport, and providing a sturdy base for installation.

COMPRESSORS

All units are provided with hermetically sealed compressors, scroll type, cooled by exhaust gas, with internal thermal insulation inside the engine, so no other additional protection is required. The compressor is fitted on vibration mountings both inside and outside.

FANS

The units are supplied with one, two outdoor fans, axial type, of direct coupling and motor with external rotor and excellent features on sound levels.

Two speeds in unit 112D to 214D.

ELECTRICAL PANEL

- Unit wiring in compliance with standard EN 60204-1.
- IP 54 water protection.
- Circuit breaker protection for compressor and fan.
- Compressor and fan working contactors.
- Terminal block and wiring for power supply to the unit.

COOLING & HEATING CIRCUIT

Made of welded dehumidifying copper tube.

The units are supplied with high and low pressure switches, with automatic reset.

Thermostatic expansion valve, 4-way valve, suction receiver and filter drier in heat pump version.

They are supplied charged with Nitrogen.

HEAT EXCHANGERS

Made of copper tubing with aluminum corrugated swirl fins, they are designed and specially dimensioned to obtain the maximum output. Also helping to reduce ice formation, the frequency of defrosting and ensuring maximum operating efficiency of the coil.

CONTROL

- Model: Climatic 40
- Control and check by microprocessor.
- Reading refrigerant temperatures.
- Reading of refrigerant pressure (heat pump units)
- Alarm signaling.
- Diagnostic per circuit.
- Adjustment of parameters adapted for operating conditions
- Hour counter and daily balance of operating time for each compressor by “first in/first out” permutation (units with two compressors).
- Remote alarm signal.
- Fan speed control (22E-86D)

OPTIONS	APPLICATION	DESCRIPTION
ARCHITECTURAL INTEGRATION		
High pressure 125 Pa FP1.	KSCM/KSHM 112D-214D	Available static pressure for outdoor unit up to 125Pa
High pressure 250 Pa FP2.	KSCM/KSHM 112D-214D	Available static pressure for outdoor unit up to 250Pa
Square discharge plenum FP1/FP2.	KSCM/KSHM 112D-214D with option FP1/FP2	Square frames for adapting discharge air from the unit to a square duct..
Inlet plenum FP1/FP2.	KSCM/KSHM 112D-214D with option FP1/FP2	Accessories for adapting the condenser air intake to a duct.
Auxiliary drip tray FP1/FP2.	KSCM/KSHM 112D-214D with option FP1/FP2	Water defrost collection.
SECURITY		
Main switch.	KSCM/KSHM 22E-214D	Electrical box access protection.
Softstarter.	KSCM/KSHM 22E-214D	It reduces the peak compressor starting current.
Return lock three phases.	KSCM/KSHM 22E-214D	It assures that unit will not begin operation on detection of overvoltage, tage, phase reversal fault or phase failure.
Protection grill.	KSCM/KSHM 22E-214D	It prevents condenser coil against accidental impacts..
COMFORT PRECISION AND ENERGY EFFICIENCY		
Low ambient kit 0°C	KSCM/KSHM 22E-214D	Operation of the unit in cooling mode until 0°C. of outdoor temperature. It is a crank case heater for the compressor.
Low ambient kit -15°C	KSCM/KSHM 22E-214D	Operation of the unit in cooling mode until -15°C. of outdoor temperature. It allows refrigerant connection between indoor and outdoor unit until 65m.
Kit low noise.	KSCM/KSHM 22E-214D	Noise level reduction. It includes compressor jacket.
Hot By-pass valve	KSCM 22E-214D	Control of capacity of evaporator by injecting hot gas by-pass.
Rubber anti-vibration mounts.	KSCM/KSHM 22E-214D	They avoid transmission of vibrations to the floor where the unit is installed, while unit is operating.
Spring anti-vibration mounts.	KSCM/KSHM 112D-214D	
SERVICE		
Factory pre-charged.	KSCM/KSHM 22E-214D	R-410A refrigerant charge and service valves.
Service valves.	KSCM/KSHM 22E-214D	Liquid and gas service valves to make easier maintenance operations.
Drive indoor motor	KSCM/KSHM 22E-214D	It includes the contactor and thermal switch, for indoor motor.
COMMUNICATION CAPABILITIES		
ModBUS	KSCM/KSHM 22E-214D	BMS as communications protocol.
EXTENDED LIFECYCLE		
Precoated coil	KSCM/KSHM 22E-214D	Protection from aggressive external environmental conditions of outdoor coil.

OUTDOOR UNIT

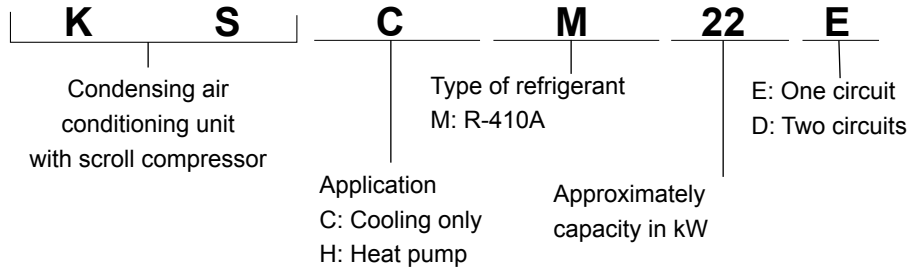

PRODUCT RANGE UNITS COOLING ONLY WITH REFRIGERANT R-410A



OUTDOOR UNIT	Ph/V/Hz	NOMINAL (*)	NOMINAL (*)
		CAPACITY kW COOLING	CONSUMPTION kW COOLING
KSCM 22E	3N~400V 50Hz	19.7	6.43
KSCM 26E	3N~400V 50Hz	24.7	8.10
KSCM 32E	3N~400V 50Hz	28.4	9.63
KSCM 38E	3N~400V 50Hz	36.1	11.9
KSCM 43E	3N~400V 50Hz	42.0	14.1
KSCM 52D	3N~400V 50Hz	49.4	16.2
KSCM 64D	3N~400V 50Hz	56.7	19.3

OUTDOOR UNIT	Ph/V/Hz	NOMINAL (*)	NOMINAL (*)
		CAPACITY kW COOLING	CONSUMPTION kW COOLING
KSCM 76D	3N~400V 50Hz	72.1	23.7
KSCM 86D	3N~400V 50Hz	83.9	28.3
KSCM 112D	3N~400V 50Hz	104	34.3
KSCM 128D	3N~400V 50Hz	115	37.1
KSCM 152D	3N~400V 50Hz	141	46.2
KSCM 214D	3N~400V 50Hz	197	63.4

(*) Evaporating temperature= +7°C / Ambient, temperature=+35°C DB/24°C WB.

PRODUCT RANGE UNITS HEAT PUMP WITH REFRIGERANT R-410A



OUTDOOR UNIT	Ph/V/Hz	NOMINAL CAPACITY kW		NOMINAL CONSUMPTION kW	
		COOLING (*)	H. PUMP (**)	COOLING (*)	H. PUMP (**)
KSHM 22E	3N~400V 50Hz	19.7	19.8	6.43	6.18
KSHM 26E	3N~400V 50Hz	24.7	25.0	8.10	7.78
KSHM 32E	3N~400V 50Hz	28.4	28.6	9.63	9.18
KSHM 38E	3N~400V 50Hz	36.1	36.0	11.9	11.1
KSHM 43E	3N~400V 50Hz	42.0	40.2	14.1	12.9
KSHM 52D	3N~400V 50Hz	49.4	50.1	16.2	15.6
KSHM 64D	3N~400V 50Hz	56.7	57.1	19.3	18.4

OUTDOOR UNIT	Ph/V/Hz	NOMINAL CAPACITY kW		NOMINAL CONSUMPTION kW	
		COOLING (*)	H. PUMP (**)	COOLING (*)	H. PUMP (**)
KSHM 76D	3N~400V 50Hz	72.1	71.9	23.7	22.2
KSHM 86D	3N~400V 50Hz	83.9	80.3	28.3	25.9
KSHM 112D	3N~400V 50Hz	104	105	34.3	32.4
KSHM 128D	3N~400V 50Hz	115	114	37.1	35.6
KSHM 152D	3N~400V 50Hz	141	137	46.2	43.8
KSHM 214D	3N~400V 50Hz	197	191	63.4	59.8

(*) Evaporating temperature= +7°C / Ambient temperature=+35°C DB.

(**) Condensing temperature 50°C/Ambient temperature 6°C WB.

DB: Dry bulb

WB: Wet bulb

PHYSICAL DATA



MODELS KSCM/KSHM			22E	26E	32E	38E	43E	52D	64D	76D	86D	112D	128D	152D	214D
Compressor	Nr / Type		1 / Scroll					2 / Scroll				3 / Scroll		4/Scroll	
			1					2				3		4	
Capacity steps	Nr		1					2				3		4	
	%		0-100%					0-50-100%				0-60-100%		0-50-100%	
Net weight	KSCM	kg	160	210	216	233	255	443	452	481	520	632	797	906	1659
	KSHM	kg	168	219	221	239	258	452	463	499	537	748	828	932	1684
Dimensions	Height	mm	1375	1375	1375	1375	1375	1375	1375	1375	1375	1875	1875	1875	1975
	Width	mm	660	980	980	980	980	1195	1195	1195	1195	1420	1420	1420	2300
	Length	mm	1195	1195	1195	1195	1195	1960	1960	1960	1960	2250	2250	2250	2250
Refrigerant connections	Liquid		1/2"	5/8"	5/8"	5/8"	5/8"	2x(5/8")	2x(5/8")	2x(5/8")	2x(5/8")	3/4"+5/8"	3/4"+5/8"	2x(3/4")	2x(7/8")
	Gas		7/8"	1 1/8"	1 1/8"	1 3/8"	1 3/8"	2x(1 1/8")	2x(1 1/8")	2x(1 3/8")	2x(1 3/8")	1 5/8"+1 3/8"	1 5/8"+1 3/8"	2x(1 5/8")	2x(1 5/8")

ELECTRICAL DATA

MODELS KSCM/KSHM			22E	26E	32E	38E	43E	52D	64D	76D	86D	112D	128D	152D	214D
Voltage	Ph/V/Hz		3N~400V-50Hz												
Max. absorbed power	kW		8.55	10.8	12.5	16.4	17.7	21.6	25.0	32.8	35.5	45.6	48.7	59.9	83.0
Maximum current	A		16.6	24.0	25.4	29.0	34.4	48.0	50.8	58.0	68.8	84.0	90.4	110	152
Start up current	A		87.5	97.4	103.7	137.7	171.7	121.4	129	167	206	221	228	292	454

MODELS KSCM/KSHM WITH FP1/FP2 OPTION		112D FP1/FP2	128D FP1/FP2	152D FP1/FP2	214D FP1/FP2
Voltage	Ph/V/Hz	3N~400V-50Hz			
Max. absorbed power	kW	47.6/51.8	50.6/54.8	60.9/65.1	88.8/97.2
Maximum current	A	87.2/93.8	93.6/100	111/118	161.2/174.4
Start up current	A	225/231	231/238	294/300	463.7/477

VOLTAGE OPERATING LIMITS: 342-462V

FAN PERFORMANCES

MODELS KSCM/KSHM			22E	26E	32E	38E	43E	52D	64D	76D	86D	112D	128D	152D	214D
Fan type	Type		Condenser fan helicoidal												
	Ph/V/Hz		1~230V-50Hz									3~400V-50Hz			
Fan number	C1+C2	r.p.m.	900	900	900	900	900	900+900	900+900	900+900	900+900	900+700	900+700	900+900	900+900
			2		1			2					4		
Air flow	C1+C2	m³/h	6800	9750	11500	11300	11000	9750+9750	11500+11500	11300+11300	11000+11000	22700+18100	22700+18100	22700+22700	28600+28600

MODELS KSCM/KSHM WITH FP1/FP2 OPTION		112D FP1/FP2	128D FP1/FP2	152D FP1/FP2	214D FP1/FP2
Fan type	Type	Condenser high static fan			
	Ph/V/Hz	3~400V-50Hz			
	r.p.m.	900 FP1 (Low speed) / 1450 FP2 (High speed)			
Fan number		2		4	

Air flow data. FP1 option.

Air flow data. FP2 option.

MODELS:		112D-128D-152D	214D
Fan type:		Axial "short case"-direct coupling 900 r.p.m.(Low speed) 3~400V	
Fan number:		2	4
Available static pressure Pa.	50	Air flow m³/h	19000+19000
		Absorbed power kW	5
	75	Air flow m³/h	18000+18000
		Absorbed power kW	5.1
	100	Air flow m³/h	17000+17000
		Absorbed power kW	5.2
125	Air flow m³/h	15000+15000	
	Absorbed power kW	5.3	

MODELS:		112D-128D-152D	214D
Fan type:		Axial "short case" direct coupling 1450 r.p.m. (High speed) 3~400V	
Fan number:		2	4
Available static pressure Pa.	150	Air flow m³/h	22000+22000
		Absorbed power kW	9.2
	200	Air flow m³/h	20000+20000
		Absorbed power kW	9.3
	250	Air flow m³/h	18000+18000
		Absorbed power kW	9.4

TECHNICAL DATA



SOUND PRESSURE / SOUND POWER LEVELS FOR OUTDOOR UNIT

KSCM/KSHM		SPECTRUM PER OCTAVE BAND (dB)							Sound power Lw dB(A)	Sound pressure at 10 m Lp dB(A)	
		125 Hz	250 Hz	500 Hz	1000 Hz	2000 Hz	4000 Hz	8000 Hz			
22E	(1)	68	71	71	71	69	67	59	76	48	
	(2)	68	71	71	71	68	65	58	75	47	
26E	(1)	74	70	72	70	73	70	62	78	50	
	(2)	74	70	70	66	72	67	62	76	48	
32E	(1)	80	72	74	75	76	71	65	81	53	
	(2)	80	72	73	74	74	66	65	79	51	
38E	(1)	80	72	74	75	75	69	62	80	52	
	(2)	80	72	73	74	73	65	62	79	51	
43E	(1)	80	72	74	76	76	68	63	81	53	
	(2)	80	72	73	74	74	65	63	79	51	
52D	(1)	77	73	75	73	76	73	65	81	53	
	(2)	77	73	73	69	75	70	65	79	51	
64D	(1)	83	75	77	78	79	74	68	84	56	
	(2)	83	75	76	77	77	69	68	82	54	
76D	(1)	83	75	77	78	78	72	65	83	55	
	(2)	83	75	76	77	76	68	65	82	54	
86D	(1)	83	75	77	79	79	71	66	84	56	
	(2)	83	75	76	77	77	68	66	82	54	
112D	Low speed	(1)	73	71	75	78	77	71	65	82	54
		(2)	73	71	72	75	71	63	65	78	50
	High speed	(1)	82	78	79	83	82	76	67	87	59
		(2)	82	78	78	82	81	74	67	86	58
128D	Low speed	(1)	73	71	75	78	78	72	66	83	55
		(2)	73	71	72	75	72	63	66	79	51
	High speed	(1)	82	78	79	83	82	76	68	87	59
		(2)	82	78	78	82	81	74	68	86	58
152D	Low speed	(1)	75	73	77	82	84	77	69	87	59
		(2)	75	73	74	77	76	66	69	81	53
	High speed	(1)	84	81	81	85	86	80	71	90	62
		(2)	84	81	80	84	84	77	71	88	60
214D	Low speed	(1)	76	75	78	82	84	76	66	88	60
		(2)	74	71	73	76	76	65	66	81	53
	High speed	(1)	79	77	80	84	85	76	67	89	61
		(2)	79	77	78	81	81	68	67	85	57
FP1 OPTION	112D	(1)	84	81	81	84	81	74	68	87	59
		(2)	84	81	80	84	80	72	68	87	59
	128D	(1)	84	81	80	84	82	75	69	88	60
		(2)	84	81	80	84	80	72	69	87	59
	152D	(1)	84	81	81	85	85	78	71	90	62
		(2)	84	81	80	84	81	72	71	87	59
	214D	(1)	87	84	84	88	86	78	71	91	63
		(2)	87	84	83	87	83	75	71	90	62
FP2 OPTION	112D	(1)	96	94	92	93	89	86	82	97	69
		(2)	96	94	92	93	89	86	82	97	69
	128D	(1)	96	94	92	93	90	86	82	97	69
		(2)	96	94	92	93	89	86	82	97	69
	152D	(1)	96	94	92	93	90	87	82	97	69
		(2)	96	94	92	93	89	86	82	97	69
	214D	(1)	99	97	95	96	93	89	85	100	72
		(2)	99	97	95	96	92	89	85	100	72

(1) The above data shows noise levels **without** compressor isolation (option).

(2) The above data shows noise levels **with** compressor isolation.

For units: KSCM/KSHM 112D to 214D

- **Low speed:** - For ambient temperatures $< +35^{\circ}\text{C}$ and unit working on cooling mode.

- For ambient temperatures $> +7^{\circ}\text{C}$ and unit working on heating mode.

- **High speed:** - For ambient temperatures $\geq +35^{\circ}\text{C}$ and unit working on cooling mode.

- For ambient temperatures $\leq +7^{\circ}\text{C}$ and unit working on heating mode.

- Global sound power level measured in compliance with ISO standard 3744 and under Eurovent certification program.

- Sound pressure in dB(A) calculated at 10 m, in a free field on a reflecting surface, is given as a guide only and with a directivity of ± 3 dBA.

- Only the sound power spectrum and the global sound power value are used in determining pressure characteristics on site.

Remark for FP1/FP2 option:

Total Lw, is global sound power level radiated for the fan motor AT FREE DISCHARGE. Sound pressure level (Lp) has to be calculated according the pressure drop introduce in the installation considering the type of the air duct, isolation class, duct length, etc ...

This value is orientative and must always consider for each installation the value of sound power level in the table to calculate the vau of sound presure level.

MODELS KSCM

22E

26E

EVAPORATING TEMPERATURE	kW	AIR ENTRY TEMPERATURE INTO THE OUTDOOR UNIT °C (DRY BULB)					AIR ENTRY TEMPERATURE INTO THE OUTDOOR UNIT °C (DRY BULB)				
		25°C	30°C	35°C	40°C	45°C	25°C	30°C	35°C	40°C	45°C
0°C	Total Capacity	17.3	16.8	15.9	14.7	13.5	21.9	21.3	20.0	18.5	16.8
	Power Input	5.27	5.55	6.01	6.67	7.42	6.71	7.01	7.64	8.46	9.41
5°C	Total Capacity	20.3	19.8	18.6	17.2	15.8	25.6	24.9	23.3	21.6	19.8
	Power Input	5.49	5.71	6.30	6.97	7.73	6.95	7.25	7.95	8.78	9.73
7°C	Total Capacity	21.6	21.0	19.7	18.3	16.8	27.2	26.4	24.7	22.9	21.0
	Power Input	5.59	5.84	6.43	7.10	7.86	7.05	7.39	8.10	8.93	9.88
10°C	Total Capacity	24.0	23.0	21.5	20.0	18.4	30.1	28.6	26.8	24.9	22.9
	Power Input	5.64	6.03	6.64	7.31	8.08	7.11	7.64	8.35	9.18	10.1
15°C	Total Capacity	n/a	n/a	n/a	n/a	n/a	n/a	n/a	n/a	n/a	n/a
	Power Input	n/a	n/a	n/a	n/a	n/a	n/a	n/a	n/a	n/a	n/a

32E

38E

EVAPORATING TEMPERATURE	kW	AIR ENTRY TEMPERATURE INTO THE OUTDOOR UNIT °C (DRY BULB)					AIR ENTRY TEMPERATURE INTO THE OUTDOOR UNIT °C (DRY BULB)				
		25°C	30°C	35°C	40°C	45°C	25°C	30°C	35°C	40°C	45°C
0°C	Total Capacity	25.4	24.7	23.0	21.1	19.1	32.0	31.4	29.4	27.3	25.0
	Power Input	7.94	8.25	9.11	10.1	11.2	9.83	10.2	11.2	12.3	13.5
5°C	Total Capacity	29.7	28.8	26.8	24.6	22.4	37.5	36.4	34.1	31.6	29.0
	Power Input	8.20	8.60	9.48	10.5	11.6	10.1	10.6	11.7	12.8	14.1
7°C	Total Capacity	31.8	30.5	28.4	26.1	23.8	40.1	38.5	36.1	33.5	30.7
	Power Input	8.21	8.76	9.63	10.6	11.7	10.1	10.8	11.9	13.0	14.3
10°C	Total Capacity	35.2	33.1	30.8	28.4	25.9	44.2	41.8	39.1	36.3	33.3
	Power Input	8.24	9.01	9.90	10.9	12.0	10.2	11.2	12.2	13.4	14.7
15°C	Total Capacity	n/a	n/a	n/a	n/a	n/a	50.4	47.5	44.5	41.2	37.8
	Power Input	n/a	n/a	n/a	n/a	n/a	10.8	11.8	12.8	14.0	15.3

43E

52D

EVAPORATING TEMPERATURE	kW	AIR ENTRY TEMPERATURE INTO THE OUTDOOR UNIT °C (DRY BULB)					AIR ENTRY TEMPERATURE INTO THE OUTDOOR UNIT °C (DRY BULB)				
		25°C	30°C	35°C	40°C	45°C	25°C	30°C	35°C	40°C	45°C
0°C	Total Capacity	37.5	36.6	34.3	31.8	29.1	43.8	42.5	40.0	37.0	33.7
	Power Input	11.6	12.0	13.2	14.5	16.0	13.4	14.0	15.3	16.9	18.8
5°C	Total Capacity	44.3	42.4	39.7	36.8	33.7	51.2	49.8	46.6	43.2	39.6
	Power Input	11.8	12.6	13.9	15.2	16.7	13.9	14.5	15.9	17.6	19.5
7°C	Total Capacity	47.4	44.9	42.0	38.9	35.7	54.5	52.7	49.4	45.8	42.0
	Power Input	11.8	12.9	14.1	15.5	17.0	14.1	14.8	16.2	17.9	19.8
10°C	Total Capacity	51.6	48.6	45.5	42.2	38.6	60.2	57.2	53.6	49.8	45.7
	Power Input	12.2	13.3	14.6	16.0	17.5	14.2	15.3	16.7	18.4	20.3
15°C	Total Capacity	58.6	55.2	51.6	47.7	n/a	n/a	n/a	n/a	n/a	n/a
	Power Input	12.9	14.1	15.4	16.8	n/a	n/a	n/a	n/a	n/a	n/a

64D

76D

EVAPORATING TEMPERATURE	kW	AIR ENTRY TEMPERATURE INTO THE OUTDOOR UNIT °C (DRY BULB)					AIR ENTRY TEMPERATURE INTO THE OUTDOOR UNIT °C (DRY BULB)				
		25°C	30°C	35°C	40°C	45°C	25°C	30°C	35°C	40°C	45°C
0°C	Total Capacity	50.8	49.4	45.9	42.2	38.2	64.1	62.7	58.7	54.5	50.0
	Power Input	15.9	16.5	18.2	20.2	22.4	19.7	20.3	22.3	24.5	26.9
5°C	Total Capacity	59.5	57.5	53.5	49.3	44.8	75.0	72.8	68.2	63.3	58.1
	Power Input	16.4	17.2	19.0	20.9	23.2	20.3	21.2	23.3	25.6	28.1
7°C	Total Capacity	63.7	60.9	56.7	52.3	47.5	80.3	77.0	72.1	66.9	61.4
	Power Input	16.4	17.5	19.3	21.2	23.5	20.3	21.7	23.7	26.1	28.6
10°C	Total Capacity	70.4	66.2	61.6	56.9	51.8	88.5	83.5	78.3	72.6	66.6
	Power Input	16.5	18.0	19.8	21.8	24.0	20.5	22.3	24.4	26.8	29.3
15°C	Total Capacity	n/a	n/a	n/a	n/a	n/a	101	95.0	88.9	82.4	75.5
	Power Input	n/a	n/a	n/a	n/a	n/a	21.7	23.6	25.7	28.1	30.7

86D

112D

EVAPORATING TEMPERATURE	kW	AIR ENTRY TEMPERATURE INTO THE OUTDOOR UNIT °C (DRY BULB)					AIR ENTRY TEMPERATURE INTO THE OUTDOOR UNIT °C (DRY BULB)				
		25°C	30°C	35°C	40°C	45°C	25°C	30°C	35°C	40°C	45°C
0°C	Total Capacity	74.9	73.3	68.6	63.6	58.3	92.0	89.1	84.1	78.0	71.5
	Power Input	23.3	24.1	26.5	29.1	31.9	28.4	29.8	32.3	35.5	39.1
5°C	Total Capacity	88.6	84.9	79.4	73.6	67.5	108	104	97.7	90.7	83.3
	Power Input	23.6	25.3	27.7	30.5	33.4	29.1	30.7	33.7	37.0	40.6
7°C	Total Capacity	94.8	89.7	83.9	77.8	71.3	115	110	104	96.1	88.2
	Power Input	23.7	25.8	28.3	31.0	34.0	29.3	31.3	34.3	37.6	41.3
10°C	Total Capacity	103.2	97.3	90.9	84.3	77.2	126	120	112	104	95.8
	Power Input	24.3	26.6	29.1	31.9	35.0	30.1	32.3	35.3	38.6	42.4
15°C	Total Capacity	117	110	103	95.5	n/a	n/a	n/a	n/a	n/a	n/a
	Power Input	25.9	28.1	30.7	33.5	n/a	n/a	n/a	n/a	n/a	n/a

n/a: Not available

COOLING CAPACITIES

MODELS KSCM

128D

152D

EVAPORATING TEMPERATURE	kW	AIR ENTRY TEMPERATURE INTO THE OUTDOOR UNIT °C (DRY BULB)					AIR ENTRY TEMPERATURE INTO THE OUTDOOR UNIT °C (DRY BULB)				
		25°C	30°C	35°C	40°C	45°C	25°C	30°C	35°C	40°C	45°C
0°C	Total Capacity	102	99.0	93.4	86.6	79.3	125	122	115	106	97.1
	Power Input	30.8	32.2	35.0	38.5	42.4	38.5	39.8	43.5	47.8	52.5
5°C	Total Capacity	119	116	109	101	92.5	146.6	142.5	133.1	123.4	113
	Power Input	31.8	33.2	36.4	40.1	44.1	39.1	41.5	45.4	49.7	54.6
7°C	Total Capacity	127	123	115	107	97.9	157	151	141	131	120
	Power Input	32.0	33.8	37.1	40.7	44.8	40.1	42.3	46.2	50.6	55.5
10°C	Total Capacity	140	133	125	116	106	174	164	153	142	130
	Power Input	32.3	34.8	38.1	41.8	45.9	40.3	43.6	47.6	52.0	56.9
15°C	Total Capacity	n/a	n/a	n/a	n/a	n/a	n/a	n/a	n/a	n/a	n/a
	Power Input	n/a	n/a	n/a	n/a	n/a	n/a	n/a	n/a	n/a	n/a

214D

n/a: Not available

EVAPORATING TEMPERATURE	kW	AIR ENTRY TEMPERATURE INTO THE OUTDOOR UNIT °C (DRY BULB)				
		25°C	30°C	35°C	40°C	45°C
0°C	Total Capacity	174	170	160	148	136
	Power Input	52.7	54.6	59.4	65.3	72.0
5°C	Total Capacity	204	199	186	173	159
	Power Input	54.7	56.7	62.1	68.3	75.3
7°C	Total Capacity	218	211	197	183	168
	Power Input	55.1	57.9	63.4	69.6	76.6
10°C	Total Capacity	241	229	214	199	183
	Power Input	55.5	59.8	65.3	71.7	78.9
15°C	Total Capacity	277	261	244	227	210
	Power Input	58.3	63.3	69.0	75.5	83.0

CAPACITY PARTIALITY

KSCM/KSHM	22E	26E a 43E	52D a 86D	112D	128D	152D	214D
Capacity steps %	0-100	0-100	0-55-100	0-35-59-100	0-38-62-100	0-30-50-100	0-28-50-78-100

CORRECTION FACTORS COOLING MODE

To find out the performances for units installed with air ducts, apply the following coefficients for capacity and consumption, over the performance tables of standard fan units without ducts.

UNITS COOLING ONLY	VERSION	MODELS	Available static pressure Pa	Maximum ambient temperature °C	Correction coefficient cooling capacity	Correction coefficient consumption ((1) only FP1/FP2)	
AIR AVAILABLE STATIC PRESSURE UP TO	50Pa	STANDARD	22E-214D	30	43	0.95	1.06
				50	39	0.89	1.16
				50	45	0.964	1.072
	125Pa	FP1	112D-214D	75	42	0.935	1.094
				100	38	0.9	1.171
				125	36	0.856	1.269
				150	47	1.01	0.98
	250Pa	FP2	112D-214D	200	44	0.97	1.037
				250	41	0.94	1.099

(1) After applying correction coefficient consumption is needed to add the following power input to get total power consumption.

EXTRA POWER CONSUMPTION				
MODELS	112D	128D	152D	214D
FP1	1.95	1.95	1	5.8
FP2	6.25	6.25	5.3	14.4

OPERATING LIMITS FOR (COOLING ONLY) UNITS

COOLING CYCLE OPERATION		MAXIMUM TEMPERATURES	MINIMUM TEMPERATURES
		INDOOR TEMPERATURE	32°C DB / 23°C WB
OUTDOOR TEMPERATURE	45°C (22E-26E-32E-52D-64D) 47°C (38E-43E-76D-86D-112D-128D-152D-214D)	+10°C STANDARD UNIT 0°C (*) -15°C (**)	

DB.- Dry bulb temperature.
WB.- Wet bulb temperature.

(*) With kit low temperature 0°C option.

(**) With kit low temperature -15°C option.

HEATING CAPACITIES

MODELS KSHM

128D

152D

CONDENSING TEMPERATURE	kW	AIR ENTRY TEMPERATURE INTO THE OUTDOOR UNIT °C (WET BULB)							AIR ENTRY TEMPERATURE INTO THE OUTDOOR UNIT °C (WET BULB)						
		-11°C	-6°C	-1°C	4°C	6°C	8°C	18°C	-11°C	-6°C	-1°C	4°C	6°C	8°C	18°C
30°C	Total Capacity	75.8	87.2	100	115	121	128	170	90.7	104	120	138	146	154	205
	Power Input	23.6	23.8	23.8	23.9	23.9	24.0	24.9	29.3	29.6	29.7	29.9	30.0	30.1	30.9
35°C	Total Capacity	75.1	86.3	99.1	113	119	126	167	90.1	103	119	136	143	152	201
	Power Input	26.0	26.2	26.3	26.3	26.3	26.3	26.9	32.2	32.4	32.6	32.7	32.8	32.9	33.5
40°C	Total Capacity	74.5	85.5	98.0	112	118	124	163	89.7	103	118	134	141	149	197
	Power Input	28.5	28.8	29.0	29.0	29.0	29.0	29.3	35.4	35.7	35.8	36.0	36.0	36.1	36.5
45°C	Total Capacity	n/a	84.7	96.9	110	116	122	160	n/a	102.0	116	132	139	147	192
	Power Input	n/a	31.8	32.0	32.1	32.1	32.1	32.2	n/a	39.3	39.5	39.6	39.7	39.7	40.0
50°C	Total Capacity	n/a	n/a	95.8	109	114	120	156	n/a	n/a	115	131	137	145	188
	Power Input	n/a	n/a	35.4	35.5	35.6	35.6	35.6	n/a	n/a	43.6	43.8	43.8	43.8	44.0
55°C	Total Capacity	n/a	n/a	n/a	107	112	118	153	n/a	n/a	n/a	129	135	142	184
	Power Input	n/a	n/a	n/a	39.4	39.4	39.5	39.4	n/a	n/a	n/a	48.5	48.5	48.5	48.7

214D

CONDENSING TEMPERATURE	kW	AIR ENTRY TEMPERATURE INTO THE OUTDOOR UNIT °C (WET BULB)						
		-11°C	-6°C	-1°C	4°C	6°C	8°C	18°C
30°C	Total Capacity	126	145	167	191	202	213	284
	Power Input	40.0	40.3	40.6	40.9	41.0	41.2	42.4
35°C	Total Capacity	125	143	165	188	199	210	279
	Power Input	43.7	44.1	44.4	44.7	44.8	44.9	45.9
40°C	Total Capacity	124	142	163	186	196	207	273
	Power Input	47.9	48.4	48.7	49.0	49.1	49.2	50.0
45°C	Total Capacity	n/a	142	162	184	193	204	267
	Power Input	n/a	53.2	53.6	54.0	54.1	54.2	54.9
50°C	Total Capacity	n/a	n/a	161	181.7	191	201	262
	Power Input	n/a	n/a	59.3	59.7	59.8	59.9	60.5
55°C	Total Capacity	n/a	n/a	n/a	180	189	198	256
	Power Input	n/a	n/a	n/a	66.2	66.3	66.4	67.0

n/a: Not available

CAPACITY PARTIALITY

KSCM/KSHM	22E	26E a 43E	52D a 86D	112D	128D	152D	214D
Capacity steps %	0-100	0-100	0-55-100	0-35-59-100	0-38-62-100	0-30-50-100	0-28-50-78-100

CORRECTION FACTORS HEATING MODE

To find out the performances for units installed with air ducts, apply the following coefficients for capacity and consumption, over the performance tables of standard fan units without ducts.

AIR AVAILABLE STATIC PRESSURE UP TO	UNITS HEAT PUMP	VERSION	MODELS	Available static pressure Pa	Maximum ambient temperature °C	Correction coefficient heating capacity	Correction coefficient consumption ((1) only FP1/FP2)
	50Pa	STANDARD	22E-214D	30	-9	0.94	1.02
50				-8	0.89	1.03	
50				-10	1	1	
125Pa		FP1	112D-214D	75	-8	0.94	1.02
				100	-6	0.89	1.03
				125	-5	0.87	1.04
				150	-10	1.01	0.99
250Pa		FP2	112D-214D	200	-10	1	1
				250	-8	0.94	1.02

(1) After applying correction coefficient consumption is needed to add the following power input to get total power consumption.

EXTRA POWER COMSUPTION				
MODELS	112D	128D	152D	214D
FP1	1.95	1.95	1	5.8
FP2	6.25	6.25	5.3	14.4

OPERATING LIMITS FOR (HEAT PUMP) UNITS

COOLING CYCLE OPERATION	INDOOR TEMPERATURE	MAXIMUM TEMPERATURE	MINIMUM TEMPERATURE
		32°C DB / 23°C WB	21°C DB / 15°C WB
HEATING CYCLE OPERATION	INDOOR TEMPERATURE	27°C DB	15°C DB
	OUTDOOR TEMPERATURE	DEPENDING ON MODELS (See tables for heating capacities)	-10°C DB / -11°C WB

DB.- Dry bulb temperature
WB.- Wet bulb temperature





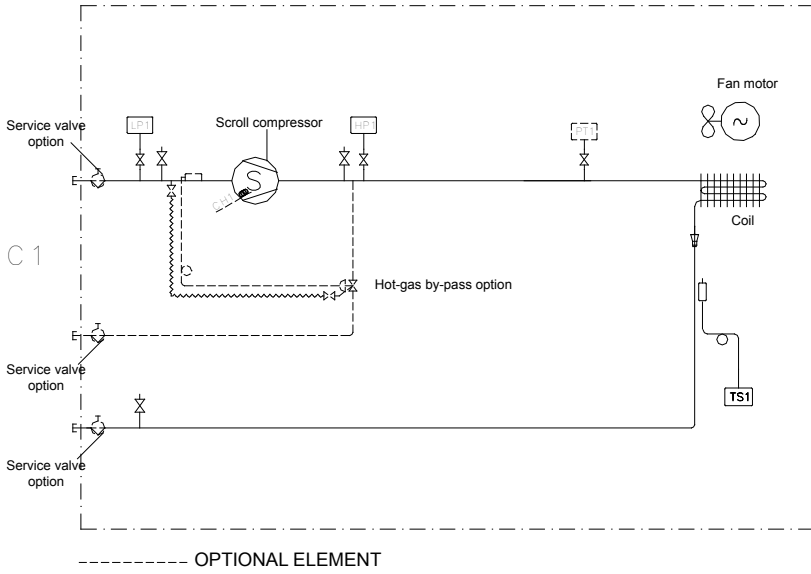



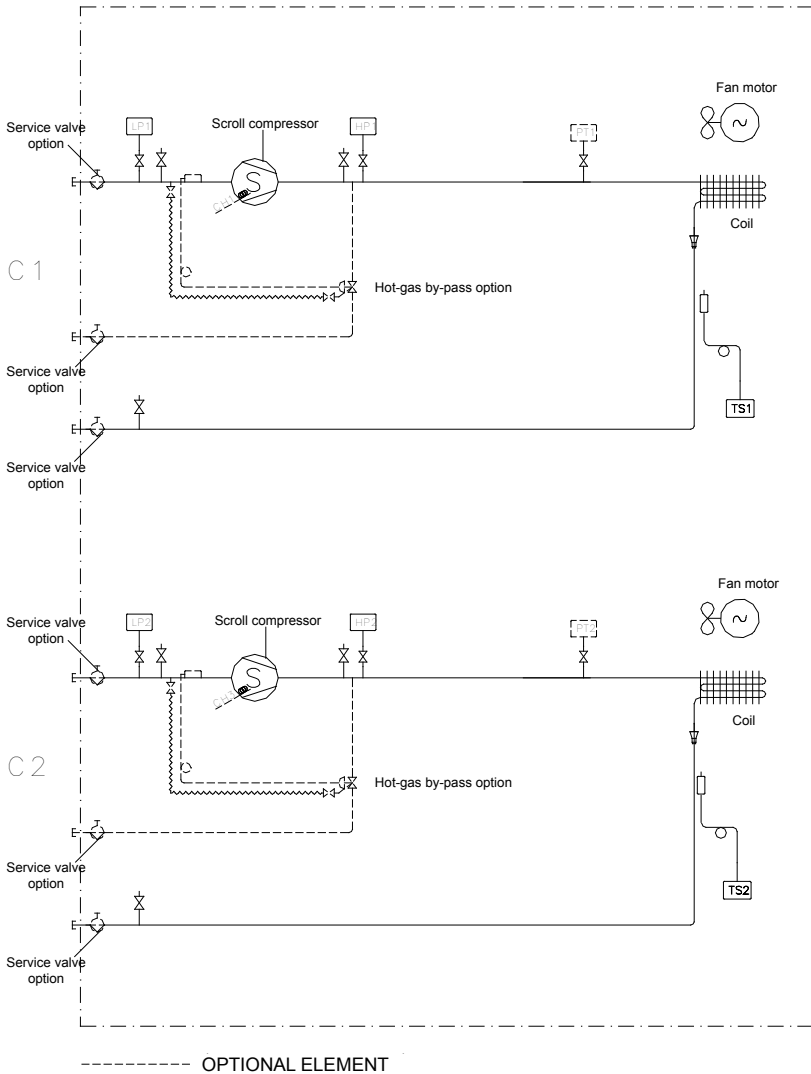

COOLING PIPING DRAWINGS

OUTDOOR UNIT
KSCM 22E/26E/32E/38E/43E



OUTDOOR UNIT
KSCM 52D/64D/76D/86D



-  Pressure gauge. (5/16" to use by the installer).
-  Low pressure switch, circuit 1.
-  Low pressure switch, circuit 2.
-  High pressure switch, circuit 1.
-  High pressure switch, circuit 2.
-  Crank case heater. (Low ambient 0°C option).
-  Crank case heater. (Low ambient 0°C option).
-  Pressure transducer, circuit 1. (Low ambient -15°C).
-  Pressure transducer, circuit 2. (Low ambient -15°C).
-  Condensing temperature sensor, circuit 1.
-  Condensing temperature sensor, circuit 2.

COOLING PIPING DRAWINGS

OUTDOOR UNIT
KSCM 112D/128D/152D

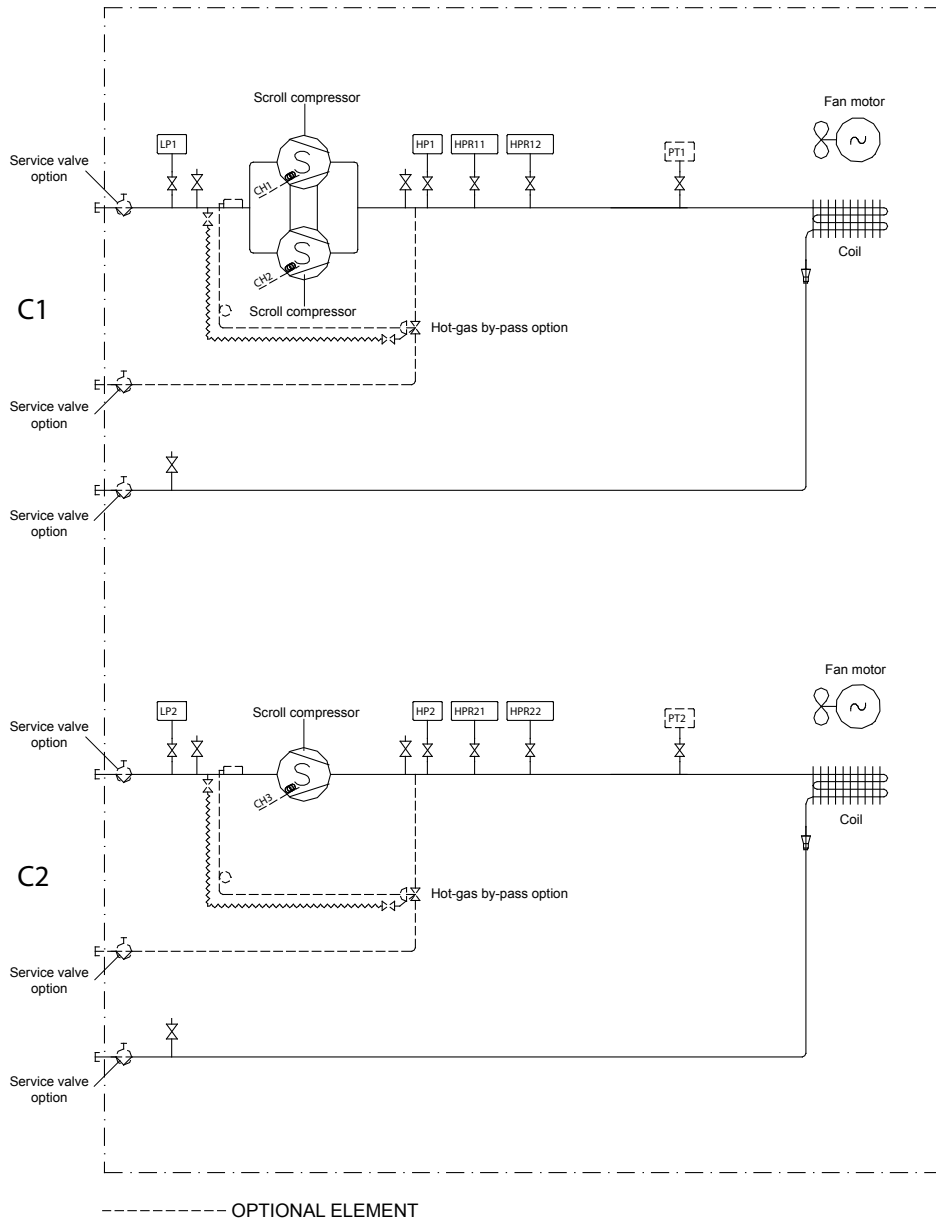

- | | | | |
|--|--|--|--|
| | Pressure gauge. (5/16" to use by the installer). | | Condensing pressure control low/high speed, circuit 1. |
| | Low pressure switch, circuit 1. | | Condensing pressure control low/high speed, circuit 2. |
| | Low pressure switch, circuit 2. | | Crank case heater. (Low ambient 0°C option). |
| | High pressure switch, circuit 1. | | Crank case heater. (Low ambient 0°C option). |
| | High pressure switch, circuit 2. | | Crank case heater. (Low ambient 0°C option). |
| | Condensing pressure control ON/OFF fan motor, circuit 1. | | Pressure transducer, circuit 1. (Low ambient -15°C). |
| | Condensing pressure control ON/OFF fan motor, circuit 2. | | Pressure transducer, circuit 2. (Low ambient -15°C). |

COOLING PIPING DRAWINGS

OUTDOOR UNIT KSCM 214D

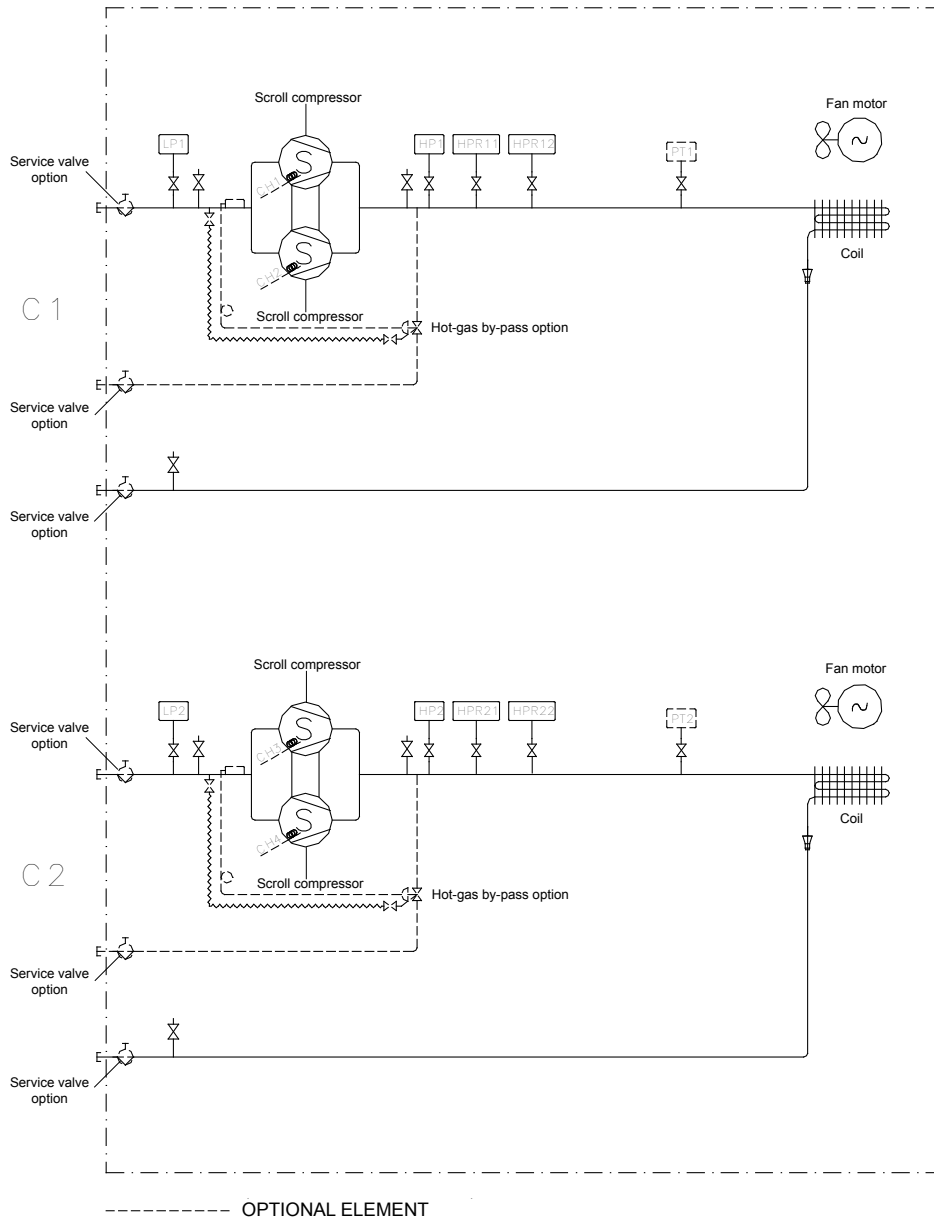







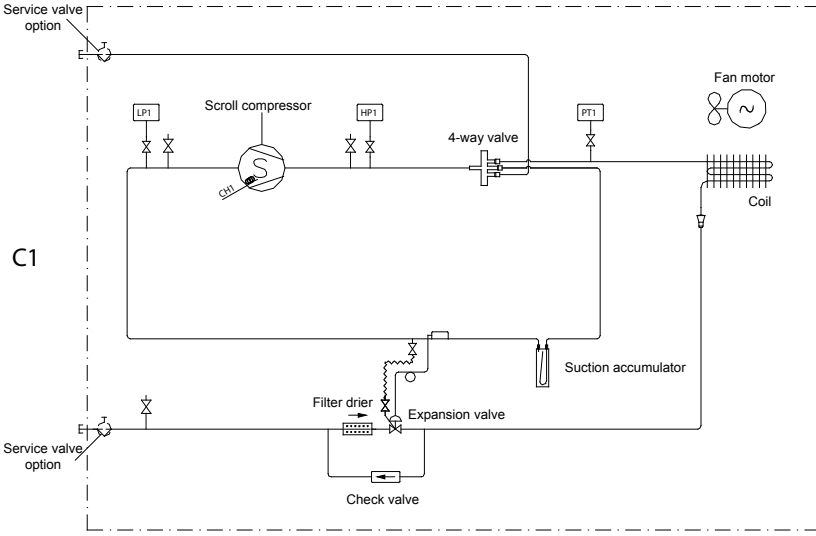



- | | | | |
|--|--|--|--|
| | Pressure gauge. (5/16" to use by the installer). | | Condensing pressure control low/high speed, circuit 1. |
| | Low pressure switch, circuit 1. | | Condensing pressure control low/high speed, circuit 2. |
| | Low pressure switch, circuit 2. | | Crank case heater. (Low ambient 0°C option). |
| | High pressure switch, circuit 1. | | Crank case heater. (Low ambient 0°C option). |
| | High pressure switch, circuit 2. | | Crank case heater. (Low ambient 0°C option). |
| | Condensing pressure control ON/OFF fan motor, circuit 1. | | Crank case heater. (Low ambient 0°C option). |
| | Condensing pressure control ON/OFF fan motor, circuit 2. | | Pressure transducer, circuit 1. (Low ambient -15°C). |
| | | | Pressure transducer, circuit 2. (Low ambient -15°C). |

HEATING PIPING DRAWINGS

OUTDOOR UNIT
KSHM 22E/26E/32E/38E/43E



OPTIONAL ELEMENT

-  Pressure gauge. (5/16" to use by the installer).
-  Low pressure switch, circuit 1.
-  Low pressure switch, circuit 2.
-  High pressure switch, circuit 1.
-  High pressure switch, circuit 2.
-  Crank case heater.
-  Crank case heater.
-  Crank case heater.
-  Pressure transducer, circuit 1.
-  Pressure transducer, circuit 2.

OUTDOOR UNIT
KSHM 52D/64D/76D/86D

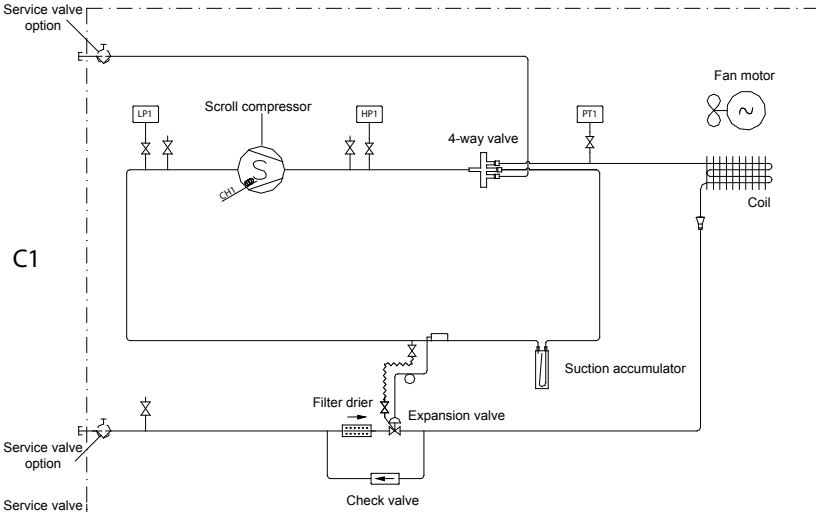

C1

OPTIONAL ELEMENT

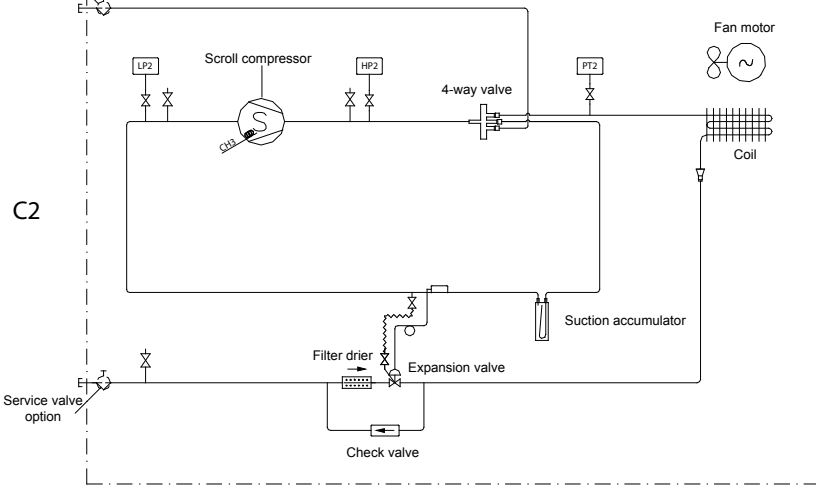

C2

HEATING PIPING DRAWINGS

OUTDOOR UNIT
KSHM 112D/128D/152D

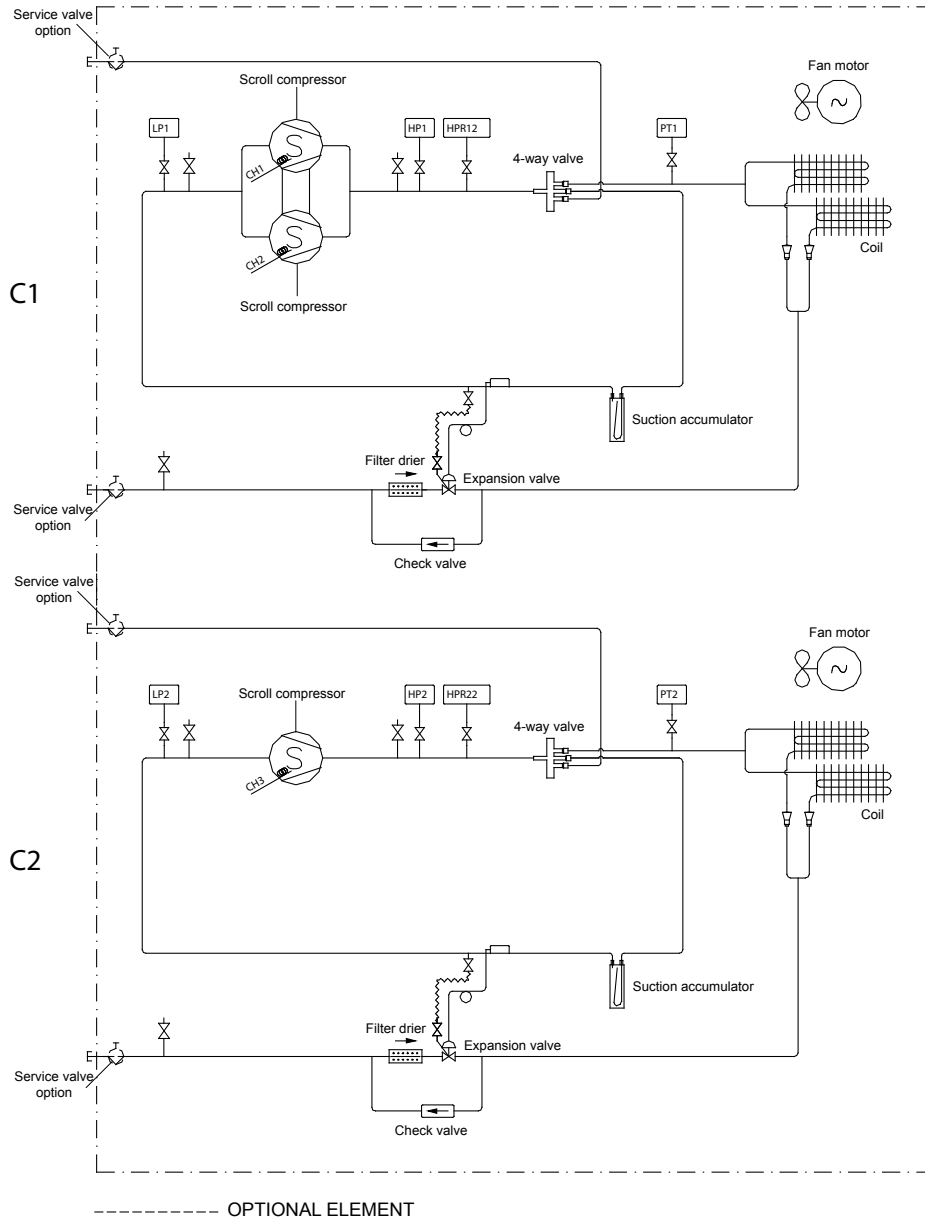

Pressure gauge. (5/16" to use by the installer).

LP1 Low pressure switch, circuit 1.

LP2 Low pressure switch, circuit 2.

HP1 High pressure switch, circuit 1.

HP2 High pressure switch, circuit 2.

HPR12 Condensing pressure control low/high speed, circuit 1.

HPR22 Condensing pressure control low/high speed, circuit 2.

CH1 Crank case heater.

CH2 Crank case heater.

CH3 Crank case heater.

PT1 Pressure transducer, circuit 1.

PT2 Pressure transducer, circuit 2.

HEATING PIPING DRAWINGS

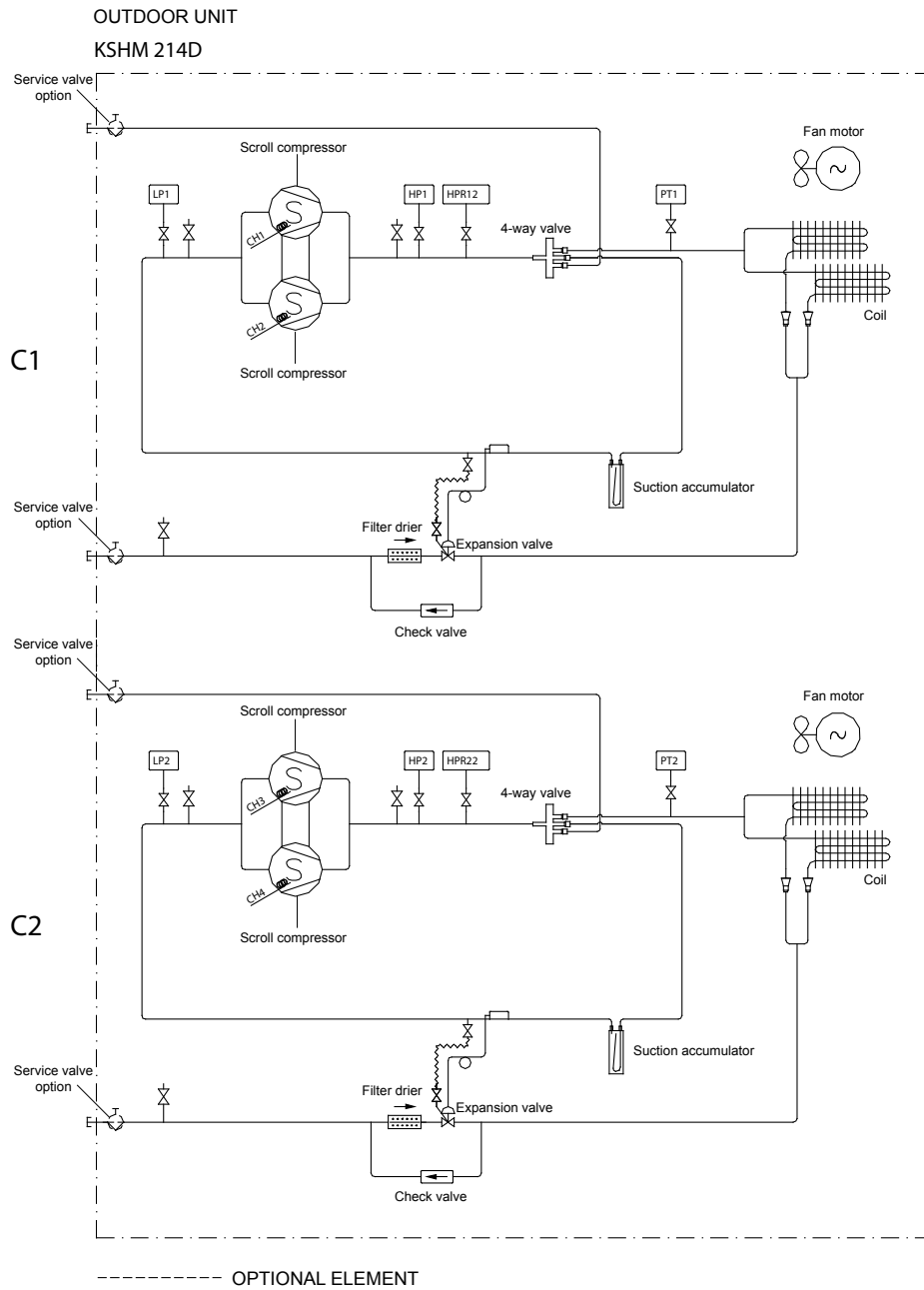



 Pressure gauge. (5/16" to use by the installer).

 Low pressure switch, circuit 1.

 Low pressure switch, circuit 2.

 High pressure switch, circuit 1.

 High pressure switch, circuit 2.

 Condensing pressure control low/high speed, circuit 1.

 Condensing pressure control low/high speed, circuit 2.

 Crank case heater.

 Crank case heater.

 Crank case heater.

 Crank case heater.

 Pressure transducer, circuit 1.

 Pressure transducer, circuit 2.

UNIT DIMENSIONS

MODELS KSCM/KSHM

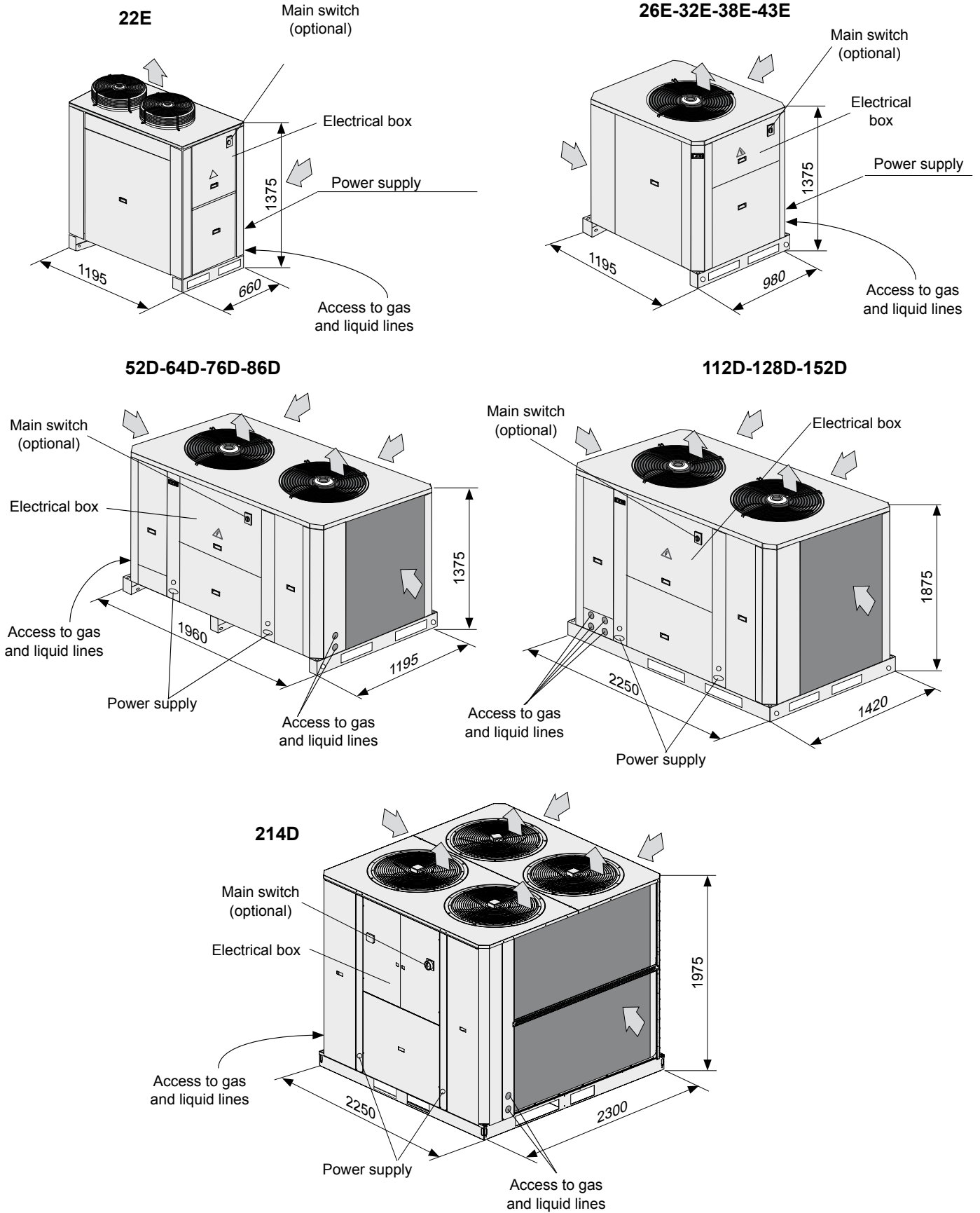

NOTE: As an option, service valves are available for liquid and gas lines with welded connection.

UNIT INSTALLATION

MOUNTING PLATES

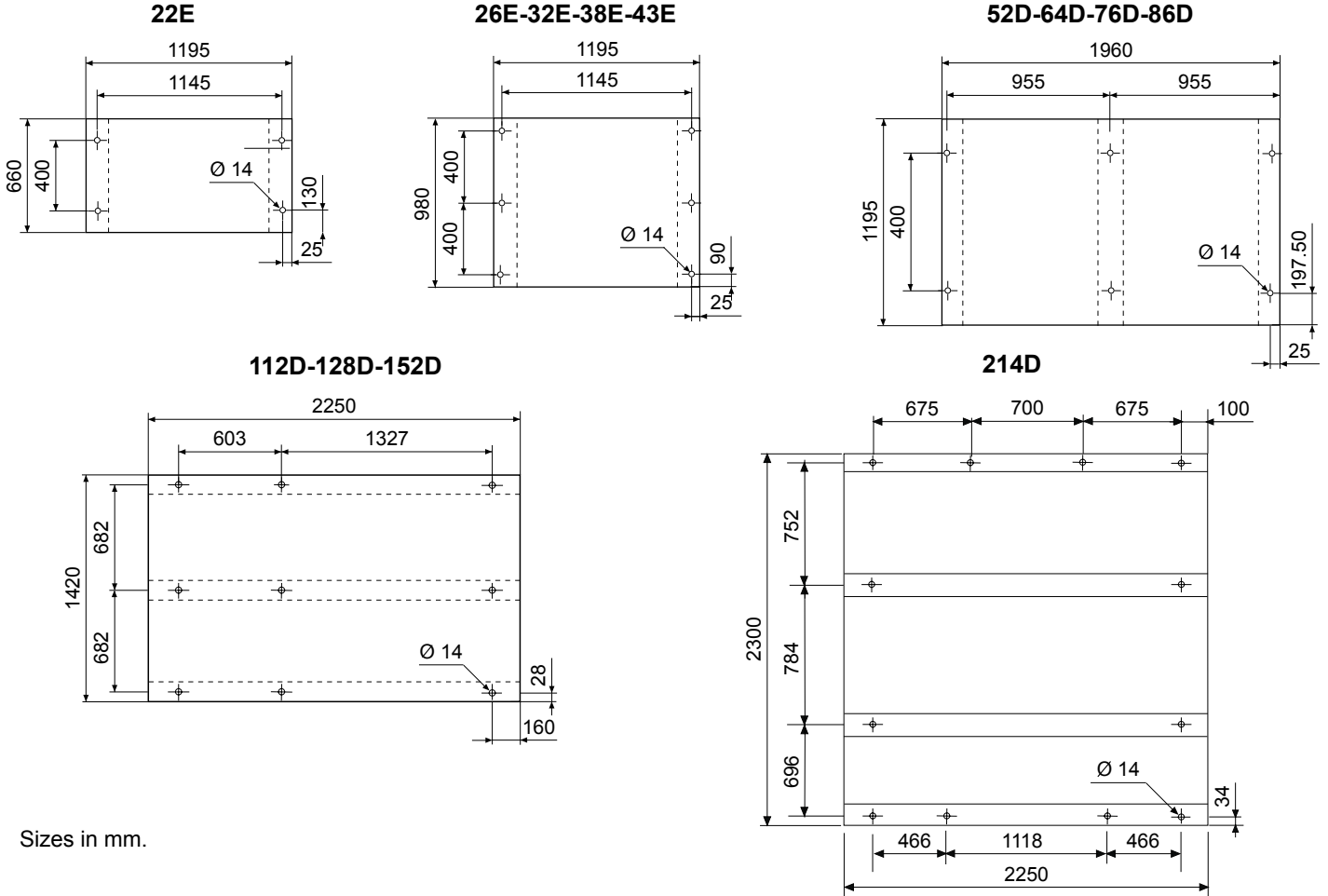

Sizes in mm.

DETAILING SPRING ANTI-VIBRATION POSITION KSCM/KSHM

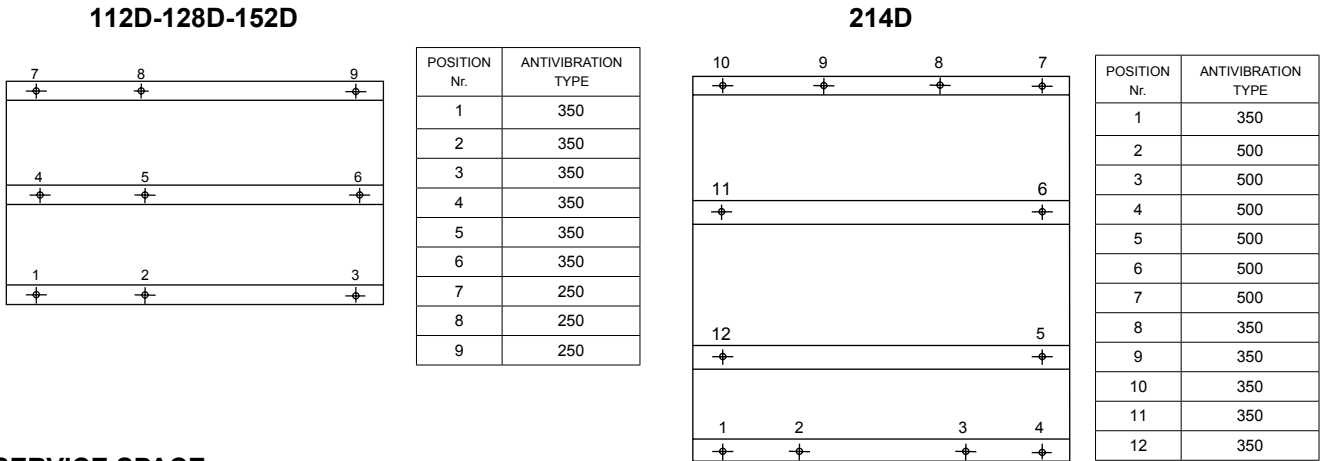

SERVICE SPACE

Space should be left free for access and servicing, and for intake and discharge air flow as well.

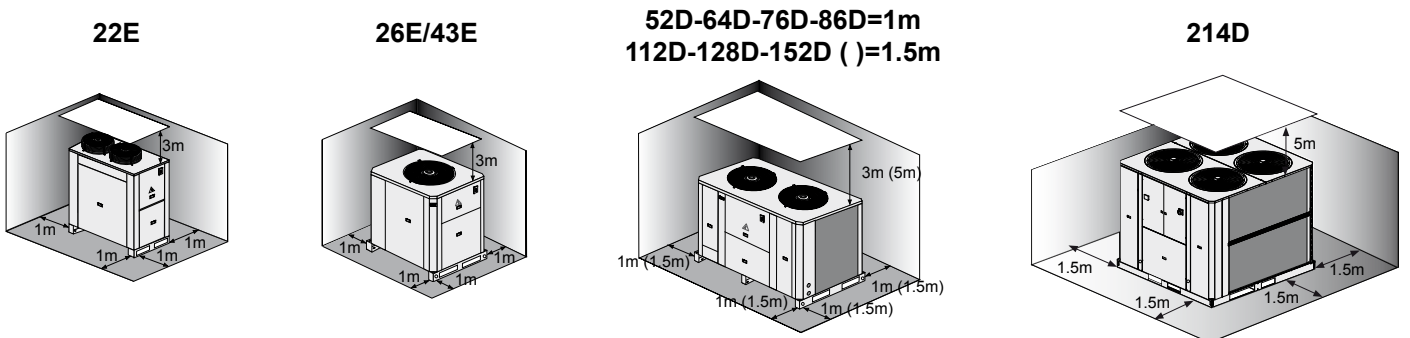

REFRIGERANT CONNECTIONS

Refrigerant connections on outdoor unit

NOTE: The unit is supplied with welded connections.

As an option, service valves are available for liquid and gas lines with welded connection.

As an option, refrigerant factory precharged kit is available (this option includes service valves).

SEE OPTION SECTION IN THIS MANUAL (pg. 22)



Piping connection lines

For calculating piping connection lines between outdoor and indoor units, distance and drop between lines are very important aspects.

To achieve the best features for the units, take special care about:

- The gas line must be always insulated.
- The horizontal lines must be sloped at least 2% toward the outdoor unit .
- The minimum speed suction must not be below 6 m/s on the vertical line of the gas line, and siphons must be installed every few meters upward to assure the oil returns to the compressor properly.
- The maximum speed inside lines should not be higher than 15m/s.

RECOMMENDATIONS FOR REFRIGERANT LINES CONNECTIONS

To locate the outdoor and the indoor units, refer to the following recommendations

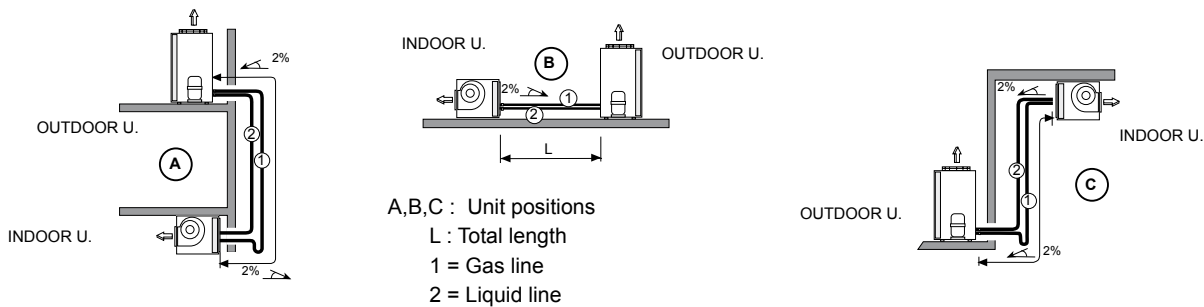

POSITION A : A siphon suction must be installed on the vertical line of the gas line, and siphons must be installed every 8 meters upward. The minimum speed suction must not be below 6m/s. Maximum vertical length 16m.

POSITION B : Tip the lines toward the outdoor unit. Make special attention to line length longer than 10m, and avoid collapse on pipe lines installation.

POSITION C : Install a siphon at the base of the vertical of the gas line, no more siphons are necessary. Maximum vertical length 6m.

TABLE 1: REFRIGERANT LINES SELECTION

REFRIGERANT LINES			UNIT - MODEL													
			22E	26E	32E	38E	43E	52D	64D	76D	86D	112D	128D	152D	214D	
Length between indoor and outdoor unit.	0 to 30 m. (Standard connection of unit)	∅ Liquid	C1	1/2"	5/8"	5/8"	5/8"	5/8"	5/8"	5/8"	5/8"	5/8"	3/4"	3/4"	3/4"	7/8"
			C2	n/a	n/a	n/a	n/a	n/a	5/8"	5/8"	5/8"	5/8"	5/8"	5/8"	3/4"	7/8"
	∅ Gas	C1	7/8"	1 1/8"	1 1/8"	1 3/8"	1 3/8"	1 1/8"	1 1/8"	1 3/8"	1 3/8"	1 5/8"	1 5/8"	1 5/8"	1 5/8"	
		C2	n/a	n/a	n/a	n/a	n/a	1 1/8"	1 1/8"	1 3/8"	1 3/8"	1 3/8"	1 3/8"	1 5/8"	1 5/8"	
	Max. Nr. of bends			6	12	8	18	12	12	8	18	12	12	12	12	12"

Maximum refrigerant piping length: 30m

PIPE CONNECTIONS



The units are factory pre-charged with Nitrogen (N₂). The installer should remove this gas and charge the units with refrigerant R-410A.

Amount of refrigerant charge R-410A for the installation

The amount of refrigerant R-410A for the system will depend on the size of connecting line between indoor and outdoor unit and on the expansion system of the indoor unit. Prior to charging the unit, a proper vacuum must be done. Finally, it is necessary to adjust the expansion system, with the unit already charged, to achieve the best features for the units, such as evaporating temperature, condensing temperature, discharge, etc.



PRECAUTIONS TO BE TAKEN IN THE USE OF R-410A Refrigerant:

R-410A Refrigerant is used in the unit; therefore, the following precautions characteristic of this gas should be taken:

- The Vacuum Pump must have a Check Valve or Solenoid Valve.
- Pressure Gauges and Hoses for the exclusive use with R-410A Refrigerant should be used.
- The charge should be carried out in the Liquid Phase.
- Always use scales to weight-in charge
- Use the Leak Detector exclusive for R-410A Refrigerant.
- Do not use mineral oil, only synthetic oil to ream, expand or make connections.
- Keep pipes wrapped before using them and be very thorough about any possible dirt (dust, filings, burrs, etc.).
- When there is a leak, gather what is left of the charge, create a vacuum in the unit and completely recharge with new R-410A Refrigerant.
- Brazing should always be carried out in a nitrogen atmosphere.
- Reamers should always be well sharpened.

TABLE 2: RECOMMENDATIONS FOR WEIGHT OF REFRIGERANT R-410A PER METER OF LINE

Liquid	Gas	gr/m
1/2"	7/8"	108
5/8"	1 1/8"	177
5/8"	1 3/8"	182
3/4"	1 3/8"	265
3/4"	1 5/8"	271
7/8"	1 5/8"	374

TABLE 3: RECOMMENDATIONS FOR CHARGE OF REFRIGERANT

Charge of refrigerant (gr) R-410A for 0 meters of line KNCM+indoor unit (Cooling only)													
	22E	26E	32E	38E	43E	52D	64D	76D	86D	112D	128D	152D	214D
C1	4655	5315	5700	7950	9745	6250	5775	7870	9800	12130	15585	15500	23100
C2	-----	-----	-----	-----	-----	6250	5775	7870	9800	10450	10045	15400	23100

Charge of refrigerant (gr) R-410A for 0 meters of line KNHM + indoor unit (Heat pump)													
	22E	26E	32E	38E	43E	52D	64D	76D	86D	112D	128D	152D	214D
C1	4900	5900	6330	8835	10830	6940	6420	8740	10900	13480	17315	17230	25660
C2	-----	-----	-----	-----	-----	6940	6420	8740	10900	11600	11160	17100	25660

PIPE CONNECTIONS

CHARGE OF REFRIGERANT FOR THE SET:

EXAMPLE:

To install a KNHM 32E + indoor unit, with 22m refrigerant line length between outdoor and indoor unit, then the refrigerant charge must be calculated as follow:

- 1.-TABLE 1 (pg.18), for 22m of line length between indoor unit and outdoor unit, the line sizes are: liquid 5/8" and gas 1 1/8".
- 2.-TABLE 2 (pg.19), for line sizes of 5/8"-1 1/8", the charge per meter line is: 177 gr/m x 22m = 3894 gr.
- 3.-TABLE 3 (pg.19), charge of refrigerant for the set with 0m of line length is: 6330 gr.
- 4.-To determine the charge of the set:

Add charge of the refrigerant lines + charge of refrigerant indoor unit and outdoor unit.

$$\text{Total charge for the set: } 3894 + 6330 = 10224 \text{ gr}$$

Note: If the outdoor unit includes factory pre-charged kit, only take care of weight of refrigerant per meter of line in TABLE 2.

112D to 152D units with 3 compressors are working using three capacity steps and 214D with 4 capacity steps. See the picture below for the installation in the case of units with tandem compressor circuit. An additional gas line has to be used to assure the correct operation of the system.

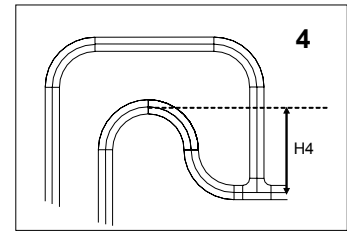
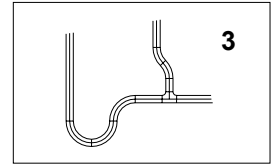
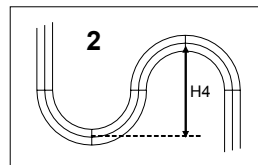
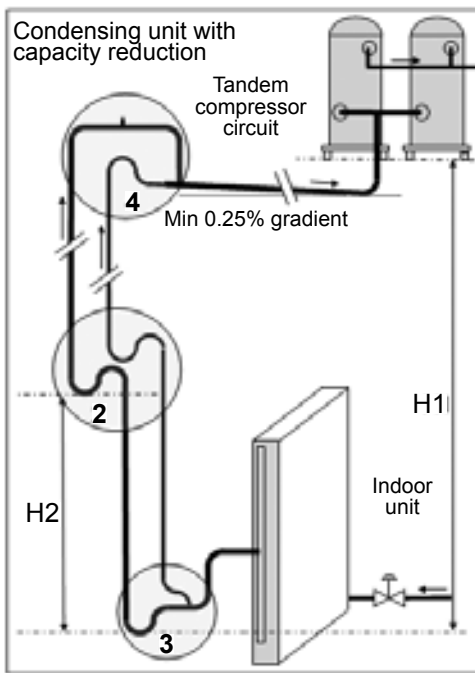

H1: 15m Max
H2: 5m Max
H4: 0,15m Min

- 2 - Coupled trap.
- 3 - Lower trap with double tubes.
- 4 - Higher trap with double tubes.

Models with tandem compressor

112D	128D	152D	214D
Circuit 1	Circuit 1	Circuit 1	Circuits 1 & 2

ELECTRICAL CONNECTIONS



- BEFORE MAKING ANY ELECTRICAL CONNECTIONS, BE SURE THAT ALL CIRCUIT BREAKERS ARE OPEN.
 - IN ORDER TO CARRY OUT ELECTRICAL CONNECTIONS, FOLLOW THE ELECTRICAL DIAGRAM SUPPLIED WITH THE UNIT.

CONDENSING UNITS

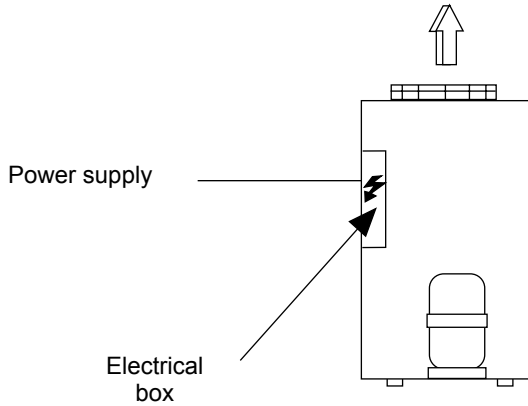

	Power supply
KSCM/ KSHM 22E	5 x 4 mm ²
KSCM/ KSHM 26E	5 x 6 mm ²
KSCM/ KSHM 32E	5 x 6 mm ²
KSCM/ KSHM 38E	5 x 6 mm ²
KSCM/ KSHM 43E	5 x 10 mm ²
KSCM/ KSHM 52D	5 x 16 mm ²
KSCM/ KSHM 64D	5 x 16 mm ²
KSCM/ KSHM 76D	3 x 25 + 2 x 16 mm ²
KSCM/ KSHM 86D	3 x 25 + 2 x 16 mm ²
KSCM/ KSHM 112D	3 x 35 + 2 x 16 mm ²
KSCM/ KSHM 128D	3 x 35 + 2 x 16 mm ²
KSCM/ KSHM 152D	3 x 50 + 2 x 25 mm ²
KSCM/ KSHM 214D	3 x 70 + 2 x 35 mm ²

ELECTRICAL CONNECTION "REMOTE SIGNALS"

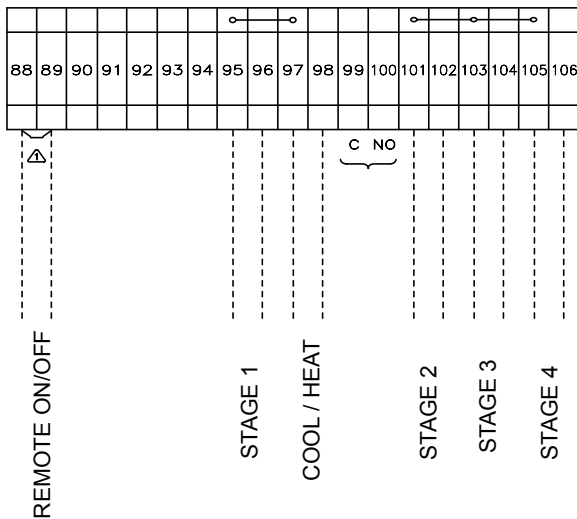

REMOTE ON/OFF: When contact is closed, unit is on.

COOL/HEAT: When contact is closed unit is running in cooling mode and when contact is opened unit is running in heating mode.

STAGE 1, 2, 3 and 4: Stage is activated when contact is closed.

	STAGE 1	STAGE 2	STAGE 3	STAGE 4
26E-43E	X			
52D-86D	X	X		
112D-152D	X	X	X	
214D	X	X	X	X



REMOVE LINK FOR REMOTE ON/OFF OPERATION

COMPRESSOR SEQUENCE ACTIVATION

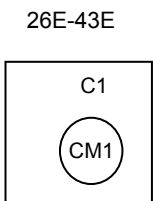

First step: Compressor 1

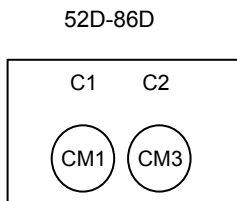

First step: Compressor 1
Second step: Compressor 3
 Automatic sequence changeover

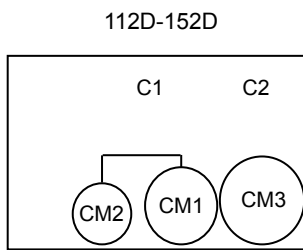

First step: Compressor 1
Second step: Compressor 2
Third step: Compressor 3

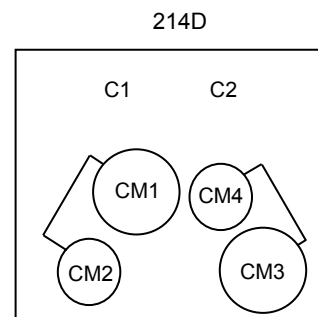

First step: Compressor 1
Second step: Compressor 2
Third step: Compressor 3
Fourth step: Compressor 4

1.- ARCHITECTURAL INTEGRATION

HIGH PRESSURE 125Pa FP1
(Only available for units 112D to 214D).
 Units with high pressure fans.
 Available static pressure up to 125Pa.

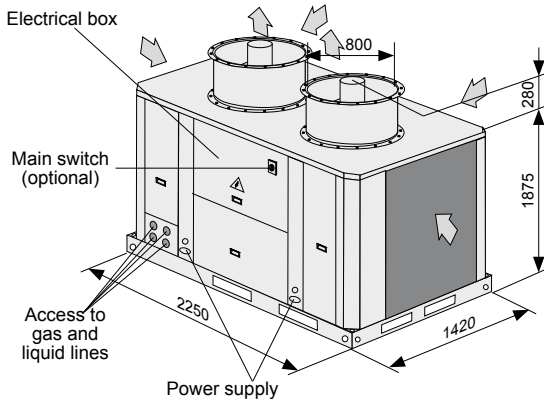

HIGH PRESSURE 250Pa FP2
(Only available for units 112D to 214D).
 Units with high pressure fans.
 Available static pressure up to 250Pa.

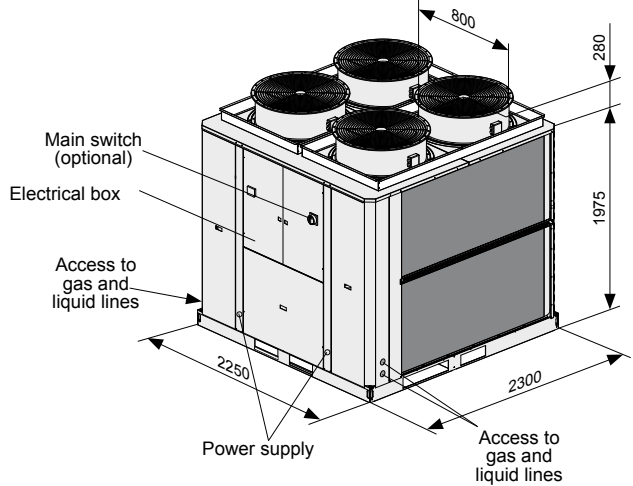

SQUARE DISCHARGE DUCT (FP1 and FP2 unit versions only).
 It is formed by 1 or 2 square frames, for adapting discharge air from the unit to a square duct.

INLET PLENUM (FP1 and FP2 unit versions only). (Supplied loose).
 It is a accessory for adapting the condenser air intake to accept a duct.

AUXILIARY DRIP TRAY (Only available for heat pump units with FP1/FP2 option).
 Heat pump units can produce a large volume of water during the defrost cycle. You can use an auxiliary drip tray under the unit to collect all the defrost water and to assist with the removal to a suitable drain.

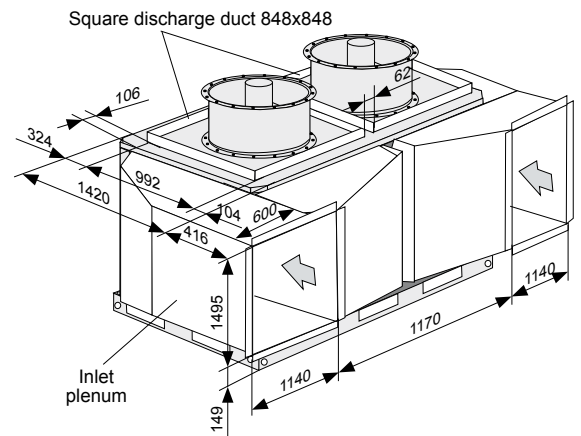

2.- SECURITY

MAIN SWITCH

The main switch is located on the access panel to the electrical box. It is equipped with a clutch gadget, which allows opening the panel of the electrical box, when it is on OFF position.

“SOFT STARTER” COMPRESSOR STARTING CURRENT CONSTRAINED.

It is an electronic element, which reduces the peak compressor starting current up to 40% (see pages of electrical data without soft starter).

RETURN LOCK THREE PHASES.

Located at electrical box of the unit. It assures that unit will not begin operation on detection of overvoltage, undervoltage, phase reversal fault or phase failure.

PROTECTION GRILL

The condenser coil protection grill prevents light damage to the coil when shipping and when installed.

3.- COMFORT, PRECISION AND ENERGY EFFICIENCY

LOW AMBIENT KIT 0° (COOLING UNITS ONLY, THE SERIES OF HEATING PUMP)

It is a crank case heater for the compressor which allows unit operation in cooling mode until 0°C of outdoor temperature. The purpose of the crank case heater is while the compressor is stopped, so that it can be properly lubricated when starts again.

LOW AMBIENT KIT -15°C (Only available for KSCM units).

It regulates the fan speed with a pressure transducer, in order to control condensing temperature. This option also includes a crankcase heater.

Thus the unit will be able to operate in the cooling cycles when the outdoor temperature is below 19°C (until -15°C). A solenoid valve has to be fitted by the installer in the liquid line (indoor unit) to prevent liquid return to the compressor. See electrical diagram supplied with the unit for the connection.

KIT LOW NOISE

Each compressor is fitted with a compressor acoustic jacket this provides attenuation of the compressor noise that radiates from the unit.

HOT GAS BY-PASS VALVE (Cooling only units).

Hot gas by-pass valve is an option that serves as extra stage of capacity control of the evaporator by injecting hot gas from high pressure side to the low pressure side after the expansion valve.

It can reduce the capacity of the unit between 40 and 80%.

HGBP valve has to be adjusted in the installation to regulate the capacity of the unit and taking into account evaporating in the compressor can not be below 2°C to prevent ice forming in the indoor coil.

The protection of indoor coil sensor is disabled by HGBP valve action.

RUBBER ANTI-VIBRATION MOUNTS

To install under the unit to avoid transmission of vibrations to the floor where unit is installed, while unit is operating. They are designed for low sensibility zones to vibration.

SPRING ANTI-VIBRATION MOUNTS (Only 112-152D units)

To install under the unit to avoid transmission of vibrations to the floor where unit is installed, while unit is operating. They are designed for medium and high sensibility zones to vibration.

4.- SERVICE

FACTORY PRECHARGED

This option includes service valves and R-410A refrigerant charged in outdoor unit (for 0 meters of connection lines).

SERVICE VALVES

As an option, the unit is fitted with gas and liquid service valves in order to make easier installation and maintenance operations.

- Valves for gas and liquid lines inside the units with welded connection for 22E to 214D.



DRIVE INDOOR FAN MOTOR OPTION

It includes the contactor and thermal switch, for indoor fan motor.

5.- COMMUNICATION CAPABILITIES

MODBUS

It is possible to connect several units with a communication system (MOD BUS Protocol).

6.- EXTENDED LIFECYCLE

PRECOATED COIL

Special protection of the aluminum condenser coil fins, to protect it from aggressive external environmental conditions.

PRELIMINARY CHECKS BEFORE FIRST OPERATION

- Check that the **power supply** is the same as stated on the Rating Plate which is in agreement with the electrical diagram for the unit and that cable sizes are correct.
- Check that **tightness of the electrical connections to their terminals and to ground.**
- Check the **control panel connections.**
(If the connection is wrong, the unit will not operate and the control panel display will not light).
- Check with your hand that the **fans turn freely.**

FIGURE FOR THE STANDARD UNIT
CONFIGURATION FOR MODELS:
52D-64D-76D-86D

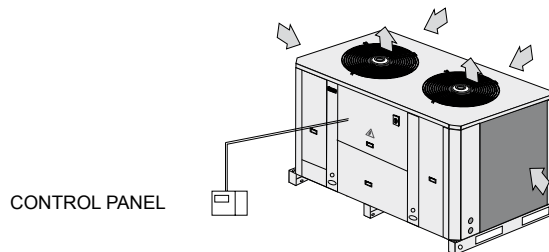

CHECK COMPRESSOR OIL LEVEL

- Part of the compressor oil is pumped to the system when the compressor start, so for splits systems part of the oil can be placed in the system: piping lines, siphons, evaporator, etc.
- Oil quantity in the system depends on refrigerant charge. The compressor can not work either refrigerant defect nor with an excessive amount of this one.
- Depending on piping length, it can be necessary to add oil to the system.
In case of having to add oil, remember the type of oil is synthetic POE.
Original oil charge in the compressor is ICI Emkarate RL32-3MAF. This type of oil has to be used too in case of replacing the oil completely.
On the other hand to add oil RL32-3MAF or Mobil EAC Artic 22C can be used.

PRELIMINARY CHECKS AT FIRST OPERATION

To start the unit, **follow the instructions given in the User Manual for the control** supplied with the unit (requesting operation in any of the modes, cooling, heating, or automatic).

After a time lapse, the unit will start.

With unit operating, check that the **fans are turning freely and in the proper direction.**



COMPRESSOR SHOULD BE CHECKED THAT ROTATES IN THE CORRECT DIRECTION.

- If you have return lock three phases as option check through it the correct rotation.
- If you do not have return lock three phases, check the correct direction of rotation. The pressure on the suction side decreases and the pressure on the discharge side increases when the compressor is activated.
- If the connection is wrong, the rotation will be reversed causing a a high noise level and a reduction in the amount of current consumed. If this occurs, the compressor's internal protection system will operate in shutting down the unit. The solution is to disconnect, switch the wires between two of the phases and connect the three again.
ASTP Protection is included with the unit compressors. See "Failure diagnosis" for more information.



WITH UNIT OPERATING, CHECK:

- Low pressure and high pressure.
- Evaporating and liquid temperature to calculate superheat and subcooling.
- Adjust according this values refrigerant charge and/or expansion valve in case it can be necessary.



COMPRESSOR OIL LEVEL

Oil level has always to be checked. When the compressor stops the level should be between 1/4 and 3/4 in the sight glass, while during operation the level should be between 3/4 and full.

In case of having to add oil, remember the type of oil is synthetic POE.

Original oil charge in the compressor is ICI Emkarate RL32-3MAF. This type of oil has to be used too in case of replacing the oil completely.

On the other hand to add oil RL32-3MAF or Mobil EAC Artic 22C can be used.

PREVENTIVE MAINTENANCE



**PREVENTIVE MAINTENANCE PREVENTS COSTLY REPAIRS.
BECAUSE OF THIS PERIODIC INSPECTIONS ARE REQUIRED:**

- GENERAL STATE OF THE CASING:

Furniture, paint, deterioration due to bumps, rust spots, leveling and supporting, state of the shock absorbers, if installed, screwed panels, etc.

- ELECTRICAL CONNECTIONS:

State of hoses, tightness of screws, grounding, current draw of the compressor and fans and checking that the unit is receiving the correct voltage.

- COOLING CIRCUIT:

Check that pressure values are correct and that there are no leaks. Check that there is no damage to the pipe insulation, that the state of the coils is correct and that there are no chips or clogs retained by the air flow, etc.

- COMPRESSOR:

Inspect the oil level, if sight glass is present.

Inspect the state of the silent block fixtures.

- FANS:

Check that fans turn freely and in the correct direction without excessive noises.

- CONTROL:

Check Set Points and normal operation.

CORRECTIVE MAINTENANCE



**IMPORTANT
MAKE SURE THAT THE UNIT IS COMPLETELY DISCONNECTED FROM THE POWER SUPPLY WHEN CARRYING OUT
ANY TYPE OF WORK ON THE MACHINE.**

If some component in the cooling circuit must be replaced, follow these recommendations:

- Always use original replacement parts.
- Remove the entire refrigerant charge from the unit through the schrader valves located in the outdoor section. Create a slight vacuum as a safety measure.
- Regulation prohibits the release of the refrigerant into the atmosphere.
- If cuts must be made in the pipe work, use pipe cutters. Do not use saws or any other tools that produce filings.
- All brazing must be carried out in a nitrogen atmosphere to prevent corrosion from forming.
- Use silver alloy brazing rod.
- Take special care that the flame from the torch is aimed in the opposite direction from the component to be welded and is covered with a wet rag in order to avoid overheating.

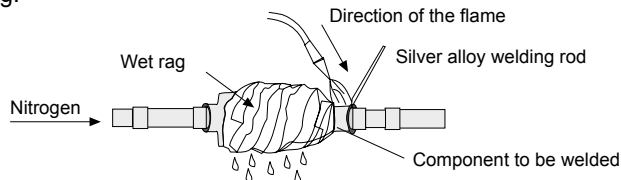

- Take very special care if 4-way check valves are to be replaced since these have internal components that are very heat-sensitive such as plastic, teflon, etc.
- If a compressor must be replaced, disconnect it electrically and un-braze the suction and discharge lines. Remove the securing screws and replace the old compressor with the new one. Check that the new compressor has the correct oil charge, screw it to the base and connect the lines and electrical connections.
- Carry out the vacuum above and below through the schrader valves of the outdoor unit until -750 mm Hg is reached. Once this level of vacuum has been reached, keep the pump in operation for at least one hour.

DO NOT USE THE COMPRESSOR AS A VACUUM PUMP.

- Charge the unit with refrigerant according to the data on the Rating Plate for the unit and **check that there are no leaks.**



PRECAUTIONS TO BE TAKEN IN THE USE OF R-410A Refrigerant:

R-410A Refrigerant is used in the unit; therefore, the following precautions characteristic of this gas should be taken:

- The Vacuum Pump must have a Check Valve or Solenoid Valve.
- Pressure Gauges and Hoses for the exclusive use with R-410A Refrigerant should be used.
- The charge should be carried out in the Liquid Phase.
- Always use scales to weight-in charge
- Use the Leak Detector exclusive for R-410A Refrigerant.
- Do not use mineral oil, only synthetic oil to ream, expand or make connections.
- Keep pipes wrapped before using them and be very thorough about any possible dirt (dust, filings, burrs, etc.).
- When there is a leak, gather what is left of the charge, create a vacuum in the unit and completely recharge with new R-410A Refrigerant.
- Brazing should always be carried out in a nitrogen atmosphere.
- Reamers should always be well sharpened.

FAILURE DIAGNOSIS

In case of failure or malfunction of the unit, the display on the control panel will show an error or alarm warning explained in the control panel manual. Nevertheless, whenever there is a unit failure, the unit should be shut down and our service technicians consulted.

FAILURE	POSSIBLE CAUSES	POSSIBLE SOLUTIONS
UNIT DOES NOT START	Failure in the power supply or insufficient voltage.	Connect the power supply or check the voltage.
	Circuit breakers have opened.	Reset.
	Power cable or control panel cable is defective.	Inspect and correct.
UNIT STOPS DUE TO HIGH PRESSURE DURING THE COOLING CYCLE	High pressure switch is defective.	Check cut-off pressure or change. Pressure switch if necessary.
	Outdoor fan is not working.	Check for voltage, inspect the motor and turbine or replace if necessary..
	Outdoor fan turns in the wrong direction.	Switch the power phases.
	Outdoor coil is dirty or clogged for passing air.	Inspect and clean.
	Excess charge of the refrigerant.	Remove the charge and charge according to the data on the rating plate.
UNIT STOPS DUE TO HIGH PRESSURE DURING THE HEATING CYCLE	The same causes and solutions as the cold cycle but with reference to the coils and indoor fan.	
UNIT STOPS DUE TO LOW PRESSURE	Low pressure switch defective.	Check the cut-off pressure with a pressure gauge and change the pressure switch if necessary.
	Indoor fan is not working.	Check for voltage and inspect the motor, turbine and replace if necessary.
	Indoor fan turns in the wrong direction.	Switch the power phases.
	Lack of refrigerant. Leak.	Correct leak, crate vacuum and charge.
	Dirty air filter.	Inspect and clean
	Clogged cooling circuit. Dirty filter drier.	Inspect and correct or change the filter drier.
UNIT STARTS AND STOPS IN SHORT CYCLES	Compressor overcharged.	Inspect suction and discharge pressure values and correct.
	Compressor cuts off due to Klixon.	Inspect input voltage and voltage drop.
	Lack of refrigerant.	Correct leak and replace.
LOAD AND ABNORMAL NOISE IN THE COMPRESSOR (SCROLL)	Power supply phases inverted (three-phase compressor).	Inspect and switch power phases.

SAFETY DEVICES

ASTP Protection:

This device protects the compressor against high discharge temperatures. When the temperature reaches critical values, ASTP protection causes "Scrolls" are separated. Compressor may stop pumping with motor running.



- Occasionally, when compressor stops and starts, there is a metallic noise because of spirals of the compressor. This is normal.
- Connect high and low pressure gauges and check that operating pressure values are normal.
- Measure electrical consumption for the unit and check that it is near what is indicated on the specification plate.
- Check the electrical consumption of the compressor and the fans with what is specified in the physical data sheets.
- In the case of a Heat Pump unit, make a cycle change on the Control Panel checking that the 4-way valve makes the change correctly. Check the pressure values in the new cycle.
- **Remember the low pressure switch is reset automatically and the high pressure switch is reset manually.**
- **Remember that low pressure switch is automatic reset, if it has 3 operations in one hour, it will be a manual reset, through the control of the unit.**

MAINTENANCE

COOLING ONLY KSCM UNITS

22E to 43E							52D to 86D							112D to 214D									
LP	STD UNIT			COOLING LAK -15°C			LP1	STD UNIT			COOLING LAK-15°C			LP1	STD/FP1/FP2 UNIT			COOLING LAK -15°C			COOLING LAK -15°C (FP1/FP2)		
	Cycle	Set	Reset	Cycle	Set	Reset		Cycle	Set	Reset	Cycle	Set	Reset		Cycle	Set	Reset	Cycle	Set	Reset	Cycle	Set	Reset
	cooling	3,5	4,5	cooling	3,5	4,5		cooling	3,5	4,5	cooling	3,5	4,5		cooling	3,5	4,5	cooling	3,5	4,5	cooling	3,5	4,5
HP		43	34	cooling	43	34	HP1	cooling	43	34	cooling	43	34	HP1	cooling	43	34	cooling	43	34	cooling	43	34
							HP2	cooling	43	34	cooling	43	34	HP2	cooling	43	34	cooling	43	34	cooling	43	34
														HPR11	cooling	22	28	FSC1 (6A)			FSC1 (12A) (112+152) FSC1 (20A) (214)		
													HPR12	cooling	37	30							
PT	n/a			(*)			PT1	n/a			(*)			PT1	n/a			(*)			(*)		
														HPR21	cooling	22	28	FSC2 (6A)			FSC2 (12A) (112+152) FSC2 (20A) (214)		
													HPR22	cooling	37	30							
							PT2	n/a			(*)			PT2	n/a			(*)			(*)		

Tables values in bar.

HEAT PUMP KSHM UNITS

22E to 43E				52D to 86D				112D to 214D			
LP	STD UNIT			LP1	STD UNIT			LP1	STD/FP1 / FP2 UNIT		
	Cycle	Set	Reset		Cycle	Set	Reset		Cycle	Set	Reset
	cooling	3,5	4,5		cooling	3,5	4,5		cooling	3,5	4,5
				LP2	cooling	3,5	4,5	LP2	cooling	3,5	4,5
HP	C/H	43	34	HP1	cooling	43	34	HP1	cooling	43	34
				HP2	cooling	43	34	HP2	cooling	43	34
								HPR12	cooling	37	30
PT	(*)			PT1	(*)			PT1	(*)		
								HPR22	cooling	37	30
				PT2	(*)			PT2	(*)		
								OT1	heating	6°C differential 2,3	

Tables values in bar.

(*) REGULATION WITH CONTROL CLIMATIC 40

1.- FAN SPEED REGULATION KSCM+KIT -15°C AND KSHM 22E-86D

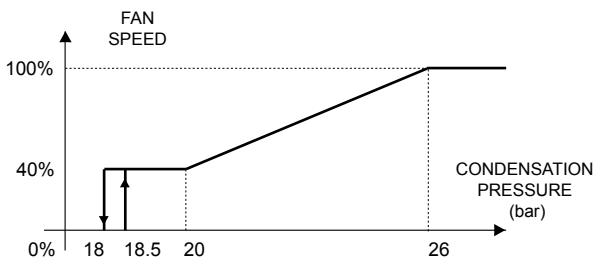

2.- DEFROST (PT/PT1/PT2)

- Start: 5,7 bars, during 60 seconds.
- End: 25 bars or passed 8 minutes, from the beginning of defrost.

1.- FAN SPEED REGULATION (PT1/PT2) KSHM STANDARD (with option FP1/FP2)

- Fan start-up 28 bar.
- Cut off 22 bar.

2.- DEFROST (PT1/PT2)

- Start: 5,7 bars, during 60 seconds.
- End: 25 bars or passed 8 minutes, from the beginning of defrost.

3.- FAN SPEED REGULATION WITH PROPORTIONAL CONTROL (FSC1/FSC2)(PT1/PT2)

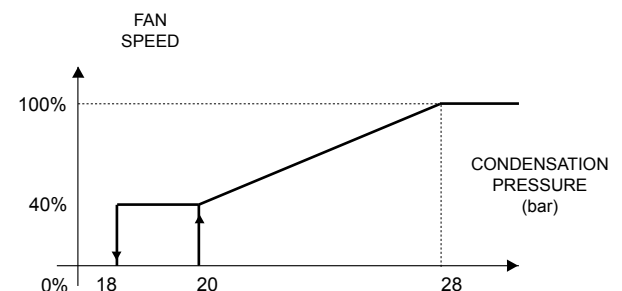

NOTES



www.lennox europe.com

BELGIUM, LUXEMBOURG
www.lennoxbelgium.com

CZECH REPUBLIC
www.lennox.cz

FRANCE
www.lennoxfrance.com

GERMANY
www.lennoxdeutschland.com

GREAT BRITAIN
www.lennoxuk.com

NETHERLANDS
www.lennoxnederland.com

POLAND
www.lennoxpolska.com

PORTUGAL
www.lennoxportugal.com

RUSSIA
www.lennoxrussia.com

SLOVAKIA
www.lennoxdistribution.com

SPAIN
www.lennoxspain.com

UKRAINE
www.lennoxrussia.com

OTHER COUNTRIES
www.lennoxdistribution.com

Due to Lennox's ongoing commitment to quality, the Specifications, Ratings and Dimensions are subject to change without notice and without incurring liability.

Improper installation, adjustment, alteration, service or maintenance can cause property damage or personal injury.

Installation and service must be performed by a qualified installer and servicing agency.



MIL84E-0607 09-2007