

WATER COOLED CHILLERS AND SPLIT UNITS

INSTALLATION OPERATION MAINTENANCE MANUAL

Ref: WC CHILLER-IOM-0108-E

The present manual applies to the following Chiller versions:

MCW Range: MCW-MCSB

Our company is a member of the Eurovent Certification Program, all LENNOX chillers are tested and rated in accordance with Eurovent certification program,

Our products comply with the European standards,

Product designed and manufactured under a quality management system certified to ISO 9001



LENNOX have been providing environmental solutions since 1895, our range of water cooled chillers continues to meet the standards that have made LENNOX a household name. Flexible design solutions to meet YOUR needs and uncompromising attention to detail. Engineered to last, simple to maintain and Quality that comes as standard. Information on local contacts at www.lennox europe.com.

All the technical and technological information contained in this manual, including any drawing and technical descriptions provided by us, remain the property of Lennox and must not be utilised (except in operation of this product), reproduced, issued to or made available to third parties without the prior written agreement of Lennox.

1 – PREFACE	4
2 – WARRANTY	6
2.1 – SAFETY	6
2.1.1 - Safety Definition	6
2.1.2 - Warning labels	6
3. INSTALLATION	7
3.1 - Transport – Handling	7
3.1.1 - Controls and delivery checks	7
3.1.2 – Storage.....	8
3.2 - LIFTING THE UNIT	8
3.2.1 - Safety instructions	8
3.2.2 – Handling	8
3.3 - LAY-OUT AND INSTALLATION REQUIREMENTS	9
3.4 - WATER CONNECTIONS	10
3.4.1 - Water connections - Evaporator/Condenser	10
3.4.2 - Water analysis	10
3.4.3 - Antifreeze protection	11
3.4.4 - Electrolytic corrosion	11
3.4.5 - Minimum water capacity	11
3.4.6 - Flow switch	11
3.5 - ELECTRICAL CONNECTIONS	11
3.6 - SOUND LEVELS	12
3.7 - CONNECTION OF SPLIT UNITS	12
3.7.1 - Liquid line sizing	12
3.7.2 - Discharge lines and suction lines	12
3.7.3 - Mechanical isolation of refrigerant lines	15
3.7.4 - Pressure test	15
3.7.5 - Refrigerant charge	16
3.7.6 - Oil charge	16
4 – PRELIMINARY CHECKS	17
4.1 – LIMITS	17
4.2 - REFRIGERATION CIRCUIT CHECKS AND RECOMMENDATIONS.....	17
4.3 - INSTALLATION OF EXTERNAL HYDRAULIC COMPONENTS	17
4.4 - CHECK LIST BEFORE START-UP	19
5 – UNIT START-UP	20
5.1 - CHECKS TO BE MADE DURING START UP	20
5.2 - OIL CHARGE	22
5.3 - REFRIGERANT CHARGE	22
6 – OPERATION	23
6.1 – OPERATING LIMITS	23
6.1.1 –MCW ALL SIZES	23
6.1.2 –MCSB WITH REMOTE CONDENSER ALL SIZES	24

6.2 - UNIT OPERATION: REFRIGERATION CIRCUIT 25
 6.2.1 – TANDEM SCROLL ASSEMBLIES 25
 6.2.2 – COPELAND SCROLL DISCHARGE TEMPERATURE PROTECTION 25
 6.2.3 – THERMOSTATIC EXPANSION VALVE 25
 6.2.4 – FILTER DRIER 25
 6.2.5 – HIGH AND LOW PRESSURE GAUGES 25
 6.2.6 – CRANKCASE HEATER 26
 6.2.7 – HIGH PRESSURE SWITCH 26

6.3 - UNIT OPERATION: ELECTRICAL AND CONTROL FEATURES 27
 6.3.1 – ANTIFREEZE PROTECTION 27
 6.3.2 – ANTI SHORT CYCLE PROTECTION 27
 6.3.3 – COMPRESSOR MOTOR OVER CURRENT PROTECTION 27
 6.3.4 – FLOW SWITCH FOR THE CHILLED WATER 27
 6.3.5 – HOT WATER CONTROL 28

6.4 – OTHER FEATURES AND OPTIONS 28
 6.4.1 – Differential oil pressure safety switch 28
 6.4.2 – Loss of power supply 28

7– MAINTENANCE 29
 7.1 WEEKLY MAINTENANCE 29
 7.2 ANNUAL MAINTENANCE 30
 7.3 CLEANING THE CONDENSER 30
 7.4 COMPRESSORS / OIL DRAINAGE 31
 7.5 IMPORTANT 31

8 – TROUBLESHOOTING – REPAIRS 32
 8.1 LIST OF THE MOST COMMON PROBLEMS 32
 8.2 CONTROL DEVICES 37
 8.3 REGULAR CHECKS TO BE MADE - CHILLER UNIT ENVIRONMENT 38
 8.4 MANUFACTURER’S RECOMMENDED INSPECTIONS 39
 8.4.1 - LIQUID CHILLERS WITH RECIPROCATING COMPRESSOR(S) 39
 8.4.2 - LIQUID CHILLERS WITH SCROLL COMPRESSOR(S) 41
 8.4.3 - LIQUID CHILLERS WITH SCREW COMPRESSOR(S) 43

CHECK LIST 45

APPENDIX 1: GENERAL REFRIGERATION CIRCUIT DRIAGRAM: MCW 47
APPENDIX 1: GENERAL REFRIGERATION CIRCUIT DRIAGRAM: MCSB 49
APPENDIX 2: GENERAL MECHANICAL DRAWING 51-56
APPENDIX 3: PRESSURE DROP 57

1 – PREFACE

You must read and be familiar with this operating manual prior to commission the chiller. Please follow the instructions closely.

We would like to stress the importance of training with respect to the correct handling of the chiller. Please consult Lennox on the options available in this field.

It is important that this manual be stored in a permanent location in the vicinity of the chiller.



IMPORTANT GENERAL INSTRUCTION

This manual contains important instructions regarding the commissioning of the chiller. It also includes important instructions to prevent personal injury and damage to the machine during operation. Furthermore, in order to promote fault-free operation of the chiller, maintenance information has been included. Please do not hesitate to contact one of our employees should you require further information on specific chiller subjects.

Order related documentation will be forwarded under separate cover.

This documentation consists of:

- **CE declaration.**
- **Operating manual for control system.**
- **Installation Operating manual**
- **Wiring diagram.**
- **Refrigerant flow diagram (except for WA-RA-WAH-LCH)**
- **Unit details are given on unit nameplate.**

The data published in this manual is based on the most recent information available. It is supplied conditional to later modifications. We reserve the right to modify the construction and/or design of our chillers, at any time, without prior notification or obligation to adapt previous supplies accordingly.



Any work on the Chiller should be carried out by trained and licensed competent technician. The following risks are present on the unit:

- **Risk of electrical shock**
- **Risk of injury from rotating parts**
- **Risk of injury from sharp edges and heavy weight**
- **Risk of injury from high pressure gas**
- **Risk of injury from high and low temperatures components.**

It is expected that all works on equipment be carried out in accordance with all local standards and norms.

It is expected that all works are carried out with good working practices.

**All Units are compliant with the PED directive 97-23-CE.
The following note must be followed carefully**

IMPORTANT NOTICE

All work on the unit must be carried out by a qualified and authorised employee.
Non-compliance with the following instructions may result in injury or serious accidents.

Work on the unit:

- . The unit shall be isolated from the electrical supply by disconnection and locking using the main isolating switch.
- . Workers shall wear the appropriate personal protective equipment (helmet, gloves, glasses, etc.).

Work on the electrical system:

- . Work on electric components shall be performed with the power off (see below) by employees having valid electrical qualification and authorisation.

Work on the refrigerating circuit(s):

- . Monitoring of the pressures, draining and filling of the system under pressure shall be carried out using connections provided for this purpose and suitable equipment.
- . To prevent the risk of explosion due to spraying of coolant and oil, the relevant circuit shall be drained and at zero pressure before any disassembly or unbrazing of the refrigerating parts takes place.
- . There is a residual risk of pressure build-up by degassing the oil or by heating the exchangers after the circuit has been drained. Zero pressure shall be maintained by venting the drain connection to the atmosphere on the low pressure side.
- . The brazing shall be carried out by a worker qualified to braze pipe work. The brazing shall comply with the standard NF EN1044 (Minimum 30% silver).

Replacing components:

- . In order to maintain CE marking compliance, replacement of components shall be carried out using spare parts, or using parts approved by Lennox.
- . Only the coolant shown on the manufacturer's nameplate shall be used, to the exclusion of all other products (mix of coolants, hydrocarbons, etc.).

CAUTION:

In the event of fire, refrigerating circuits can cause an explosion and spray coolant gas and oil.

2 – WARRANTY

The warranty of the chillers is subject to the warranty definitions as agreed upon in the order. It is expected that the design and installation of the unit utilises good working practices.

The warranty will be legally nil and void if:

- ***Service and maintenance have not been executed in accordance with the regulations; repairs have not been carried out by Lennox personnel or have been implemented without prior written permission by Lennox.***
- ***Modifications have been made to the equipment without prior written permission by Lennox.***
- ***Settings and protections have been modified without prior written permission by Lennox.***
- ***Non-original or other than the prescribed refrigerants or lubricants are used.***
- ***The equipment has not been installed and/or connected in accordance with the installation instructions.***
- ***The equipment is being used improperly, incorrectly, negligently or not in accordance with its nature and/or purpose.***
- ***A flow protection device is not fitted.***

In these circumstances Lennox is indemnified from any product liability claims from third parties.

In the event of a warranty claim the machine serial number and Lennox order number must be quoted.

2.1 - SAFETY

The safety information contained in this manual is provided as a guide for the safe handling of this installation. Lennox does not vouch for the completeness of this information and can therefore not accept liability for any possible omissions.

In the chillers, heat is being transported by a pressurised refrigerant, with changes in pressure and temperature. The protection of operating and maintenance personnel was central in the design of the chiller. Safety features have been included to prevent excessive pressure in the system. Sheet metal parts have been fitted to prevent inadvertent contact with (hot) pipes.

The electrical control panel is completely touch-proof. This excludes some parts operating at a safe voltage (< 50 Volt). The service panels can only be opened using tools.

Notwithstanding that the chillers are equipped with extensive safety and protection features, the utmost care and attention is needed when carrying out operations on the machine. Furthermore, ear protection should be worn when working on or in the vicinity of the chillers. Operations on the cooling circuit or electrical equipment should be carried out by authorised personnel.

2.1.1 - Safety Definition

The water cooled chillers meet the following safety definitions:

- Pr-EN-378-1.
- EU Directive 89/392/EG ("Machine Directive").
- EN-60204-1.
- "EMC Directive".
- Pressure Equipment Directive 97/23/CE.

And is provided with CE markings (on the condition that the necessary options are present) (for further information see II-A declaration).

2.1.2 - Warning labels

The chiller is marked with the following warning labels to alert to potential hazards (on or near the potentially hazardous part).



High temperatures



Electrical Voltage



Rotating parts



Sharp parts

Check regularly that the warning labels are still in the correct positions on the machine and replace them if necessary.

3 – INSTALLATION

3.1 - Transport - Handling

3.1.1 - Controls and delivery checks

On receipt of anew equipment please check the following points. It is the customer’s responsibility to ensure that the products are in good working order (fill the check list page 50):

- The exterior has not been damaged in any way.
- The lifting and handling equipment are suitable for the equipment and comply with the specifications of the handling instructions enclosed here-in.
- Accessories ordered for on site installation have been delivered and are in good working order.
- If the unit is delivered with its operating refrigerant charge, that there has been no leakage (use an electronic detector).
- The equipment supplied corresponds to the order and matches the delivery note.

If the product is damaged, exact details must be confirmed in writing by registered post to the shipping company within 48 hours of delivery (working days).

A copy of the letter must be addressed to LENNOX and the supplier or distributor for information purposes. Failure to comply will invalidate any claim against the shipping company. Please be reminded that LENNOX is not responsible for off-loading and positioning.

3.1.1.1: Unit Nameplate

The rating plate provides a complete reference for the model and ensures that the unit corresponds to the model ordered. It states the electrical power consumption of the unit on start-up, its rated power and its supply voltage.

The supply voltage must not deviate beyond +10/-10 %.

The start-up power is the maximum value likely to be achieved for the specified operational voltage. The customer must have a suitable electrical supply. It is therefore important to check whether the supply voltage stated on the unit’s rating plate is compatible with that of the mains electrical supply. The rating plate also states the year of manufacture as well as the type of refrigerant used and the required charge for each compressor circuit.

		Factory Mions Z.I LES MEURIERES 69780 MIONS FRANCE				 0062	
Unit type: MCW 262 S K AXIMA							
Serial NR: 138173/01							
	Voltage (V)	Phase (Ph)	Frequency (Hz)		Current (A)		
Elec supply	400	3	50		Nominal	Starting	
Elec auxiliary	24	1	50		172	430	
		Min			Max		
		Test	Service		Test	Service	
Pressure (bar)		15	19		29	32	
Temperature (°C)		-20			50		
Capacities (Kw)		Ref charge (Kg)				Dates	
Cooling	Heating	C1	C2	C3	C4	Prod.	Test
345	0	17	17	0	0	2007	14/01/08
Fluid		Fluid group		Energy class		Weight (Kg)	
R407C		2				950	
This product is used for Air Conditioning							

3.1.2 - Storage

When units are delivered on site they are not always required immediately and are sometimes put into storage. In the event of medium to long-term storage, we recommend the following procedures:

- Ensure that there is no water in the hydraulic systems.
- Keep the heat exchanger covers in position.
- Keep protective plastic film in position.
- Ensure the electrical panels are closed.
- Keep all items and options supplied in a dry and clean place for future assembly before using the equipment.

It is strongly recommended to store units in a dry, sheltered place (in particular for units that will be installed indoor).

3.2 - LIFTING THE UNIT

3.2.1 - Safety instructions

Installation, start up and adjustment of this equipment can be dangerous if certain system specific factors are ignored, such as operating pressures, electrical components, locations (roofs, terraces and other structures located well above ground level).

Only highly qualified contractors and technicians with sound knowledge of this type of equipment, are authorised to install, start up and service it.

During any service operations, observe the recommendations given on labels or instructions sent with the equipment, as well as any other applicable safety procedures.

- Follow all safety rules and regulations
- Wear protective glasses and work gloves
- Handle heavy or bulky equipment carefully during lifting and moving operations, and when setting it on the ground.

CAUTION: BEFORE EACH SERVICE OPERATION MAKE SURE THAT THE UNIT POWER SUPPLY IS PROPERLY ISOLATED AND LOCKED OUT.

NOTE: SOME UNITS MAY HAVE A SEPARATE 230V CONTROL SUPPLY THAT REQUIRES SEPARATE ISOLATION. PLEASE CHECK THE WIRING DIAGRAM.

3.2.2 - Handling

Handling operations must be carried out by qualified personnel. Comply strictly with lifting instruction pasted on the unit. Unit handling operations must be carried out carefully to avoid jolting the frame, the panels, the electrical box, etc....

NOTE:

The machine is also wrapped in packing foil. It is recommended to leave this protection in place during any transport and lifting operations, and not to remove the plastic plates until commissioning (take care that the protecting foil wrapping is not blown away!).

NOTE:

Rubber anti-vibrations mountings (AVM) & factory accessories are to be found in the control panel or in an extra box for shipping. If the unit is mounted on anti-vibration mountings, these should be fitted to the unit before final positioning.

3.3 - LAY-OUT AND INSTALLATION REQUIREMENTS

The following preparations are important for the installation of the chiller:

- Water -cooled chillers such as Hydrolean or MCW are designed for indoor installation. Please consult Lennox prior to implementing other types of installation.
- The ground beneath the unit must be flat, level and of sufficient strength to support the weight of the unit with its full liquid charge, and the occasional presence of the usual service equipment.
- In locations exposed to frost, the supporting surface, if the unit is installed on the ground, must be built on concrete stakes extending downwards beyond the normal depth of frost. It is always advisable to build a supporting surface detached from the general building structure to avoid transmission of vibrations.
- On normal applications, unit rigidity and point load positions enable installation to minimise vibrations. Vibration isolators may be used by contractors on installations requiring particularly low vibration levels.



Use of vibration isolators MUST be accompanied by installation of flexible connections in the unit water piping. Vibration isolators must also be secured to the unit BEFORE being attached to the ground. Selection of vibration absorbing isolator capacity is not Lennox's responsibility.

- The unit must be bolted to the vibration isolators and the latter solidly secured into the concrete slab. Check that vibration isolator contact surfaces fit flush to the floor. If necessary, use spacers or re-surface the flooring, but in all events, make sure that the isolators seat flatly on the supporting surface.
- It is essential that the units be installed with sufficient free space around them to provide easy access to all unit components for servicing and maintenance.

It is important that units must be levelled. Failure to install unit correctly will void warranty.

CLEARANCES DRAWINGS

Please consult the mechanical drawings or the drawings supplied with the ordered unit.

For any chiller a minimum distance of 1 meter is required for the good opening and servicing of the electrical box.

3.4 - WATER CONNECTIONS

3.4.1 - *Water connections - Evaporator/Condenser*

The water circulating pump will be preferably installed upstream so that the evaporator/condenser will be subjected to positive pressure. Entering and leaving water connections are indicated on the certified drawing sent with the unit or shown in the sales brochure.

For shell and tube heat exchangers, a drainage plug is located at the base of the evaporator. A drainage pipe may be connected to this to enable drainage of evaporator water for service operations or for seasonal shut down.

The use of a water filter in the water circuit upstream of the heat exchanger is mandatory. These filters must remove all particles with a diameter greater than 1 mm, and must be positioned within 1 meter of the inlet of the exchanger. They may be supplied as an option by the manufacturer.



LACK OF FILTER AT THE INLET OF A PLATE HEAT EXCHANGER WILL MAKE WARRANTY VOID.

Hydraulic drawings in Appendices, or supplied with the unit.

3.4.2 - *Water analysis*

The water must be analysed; the water circuit installed must include all items necessary for treatment of the water: Filters, additives, intermediate exchangers, bleed valves, vents, isolating valves, depending on the results of the analysis.



We do not advise operation of the units with open loops, which can cause problems with oxygenation, nor operation with untreated ground water.

Use of untreated or improperly treated water can cause deposits of scale, algae and sludge or cause corrosion and erosion. It is advisable to call in a qualified water treatment specialist to determine what kind of treatment will be necessary. The manufacturer cannot accept liability for damage caused by the use of untreated or improperly treated water, salt water or brine.

3.4.3 - Antifreeze protection

3.4.3.1: Use glycol/water solution

ADDITION OF GLYCOL IS THE ONLY EFFICIENT WAY TO PROTECT AGAINST FREEZING



The glycol/water solution must be sufficiently concentrated to ensure proper protection and prevent formation of ice at the lowest outdoor air temperatures expected on an installation. Take precautions when using non-passivated MEG antifreeze solutions (Mono Ethylene Glycol or MPG Mono Propylene Glycol). Corrosion can occur with these antifreeze solutions with oxygen.

3.4.3.2: Drain the installation



It is important to make sure that manual or automatic air bleeders are installed at all the high points of the water circuit. To enable drainage of the circuit, make sure that drain cocks are installed at all the low points of the circuit. To drain the circuit, the drain cocks must be opened and an air inlet ensured. Note: air bleeders are not designed to admit air.

FREEZING OF A HEAT EXCHANGER DUE TO COLD WEATHER CONDITIONS IS NOT COVERED BY LENNOX WARRANTY.

3.4.4 - Electrolytic corrosion



We would like to draw your attention to the problems of corrosion due to electrolytic corrosion caused by an imbalance between earthed points.

AN EXCHANGER THAT IS PUNCTURED BY ELECTROLYTIC CORROSION IS NOT COVERED BY THE UNIT WARRANTY

3.4.5 - Minimum water capacity



The minimum volume of the chilled water circuit must be calculated with the formula here under. If necessary, install a buffer tank. Proper operation of regulating and safety devices can only be ensured if the volume of water is sufficient. The theoretical volume of the water loop for a proper air conditioning operation can be calculated using the formula hereafter:

- Q → Cooling capacity of the chiller in kW
- N → Number of capacity stage of the chiller
- Dt → Water temperature Delta T.

$V_t = 72 \times Q / (n \times dt) \text{ litres}$

Example, for a chiller with 100kW, water conditions 12°C/7°C and 4 capacity stages, the minimum volume is: $V_t = 72 \times 100 / (5 \times 4) = 360 \text{ L}$

This formula will give the minimum water capacity of the installation that will accept a temperature rise of the water loop of (dt/n)°C during anti short cycle of compressors.

This formula is only applicable for air-conditioning installation and must not be used for process cooling where temperature stability is required.

3.4.6 - Flow switch



A flow switch must be installed on the evaporator water inlet or outlet, so as to enable detection of water flow through the heat exchanger before the unit is started up. This will protect the compressors against any eventual liquid slugging during the starting phase and prevent accidental ice formation in the evaporator, if the flow of water is interrupted.

Flow switches are available as standard on certain units and always as option. The normally open contact of the flow switch should be connected to the terminals provided to that effect in the unit electrical box. (See the wiring diagram supplied with the unit). The normally closed contact can be used as an indication of a lack of flow condition.

Warranty is void if a flow detection device is not fitted and connected to the LENNOX control panel.

3.5 - ELECTRICAL CONNECTIONS

First of all, make sure that power supplies from the building to the place where the unit is installed are properly established and that wire gauges are in keeping with the start up and running currents. Check tightness of all electrical connections. You **MUST** make absolutely certain that the power supplies applied to the power and control circuits are those for which the electrical panel was manufactured.

A main isolator switch must be inserted between the end of the power supply cable and the unit to enable total isolation of the latter when necessary. Chillers are usually supplied with a main isolator switch. If not it is available as an option.

WARNING



Wiring must conform to applicable regulations. The type and location of fused isolators must also conform to regulations. For the sake of safety, install them where they can be seen and in easy reach of the unit. Units must have full earthed continuity.

IMPORTANT



Operation of a unit with the wrong power supply or with excessive phase imbalance constitutes abuse and is not covered by the LENNOX warranty. If phase imbalance exceeds 2 % for voltage and 1 % for current, contact your local electricity company immediately before powering up the unit.

3.6 - SOUND LEVELS

Liquid chillers can be a significant source of noise in refrigeration and air conditioning systems.

Account is taken of technical constraints, both in design and manufacturing, sound levels cannot be improved much further than specified.

Sound levels must therefore be accepted for what they are, and the area surrounding the chillers should be treated as necessary. The quality of installation can either improve or decrease initial sound characteristics: it may be necessary to provide further treatment such as sound-proofing or installation of screens around units installed externally.

The choice of the location for the installation can be of great importance: reflection, absorption, transmission of vibrations.

The type of unit support is also very important: inertia of the room and the structure of the walling, interfere with the installation and its behaviour.

Before taking any other steps, first determine whether the sound level is compatible or not with the environment, what it is perfectly justifiable and that these measures envisaged will not cause unreasonable cost.

Determine what level of sound proofing is necessary on the equipment, the installation (silencer, vibration isolators, and screens) and on the building (reinforcement of flooring, false ceilings, and wall coverings).

It may be necessary to contact an engineering office that specialises in sound abatement.

3.7 - CONNECTION OF SPLIT UNITS

Connections between the unit and the condenser must be made by a qualified refrigeration engineer and require several important precautions.

In particular, the shape and dimensions of the hot gas lines must be carefully designed to ensure proper oil return in all cases and prevent liquid from returning into the cylinder heads when the compressor is stopped. On units fitted with capacity reducers, the piping sizes must be calculated so that gas velocity is sufficiently high when the unit is operating on capacity reduction.

Non application of these precautions will cancel the compressor warranty.

We recommend following ASHRAE recommendations.

3.7.1 - Liquid line sizing

Determine the size of liquid lines using:

- 1) Operating conditions at full load.
- 2) Maximum pressure drop of 100 kPa
- 3) Liquid velocity below 2 m/s (to avoid liquid slugging).
- 4) For liquid risers, make sure that liquid sub cooling is sufficient to counteract the loss of static pressure and prevent gas flashing.

3.7.2 - Discharge lines and suction lines

Calculate these to obtain a gas velocity in vertical sections that enables compressor oil migration and steady return to the compressor (tables C and D).

Determine the dimensions of vertical lines using the following tables.

Horizontal lines may be bigger in order to compensate pressure drop in vertical lines.

The total pressure drop in the piping has to be lower or equal to 1°C at saturation pressure on the suction side.

Units with remote condenser

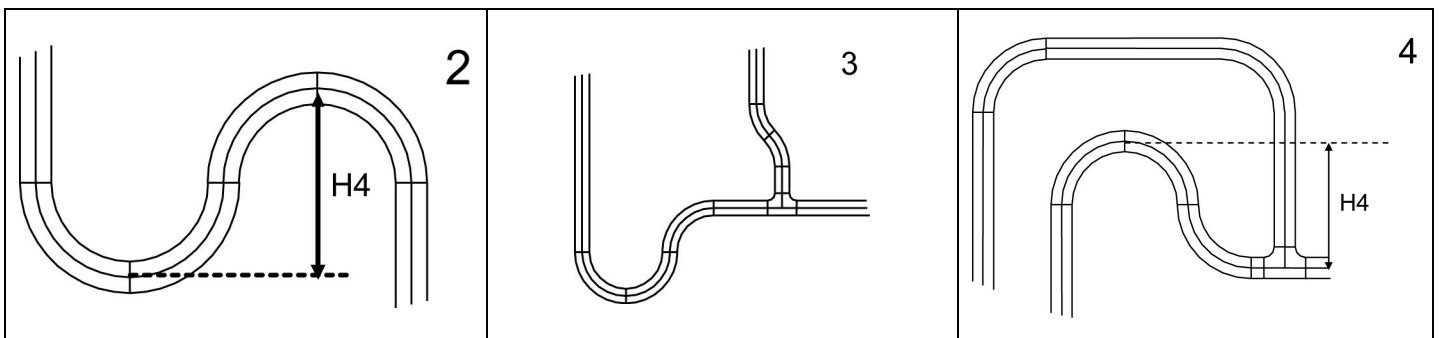
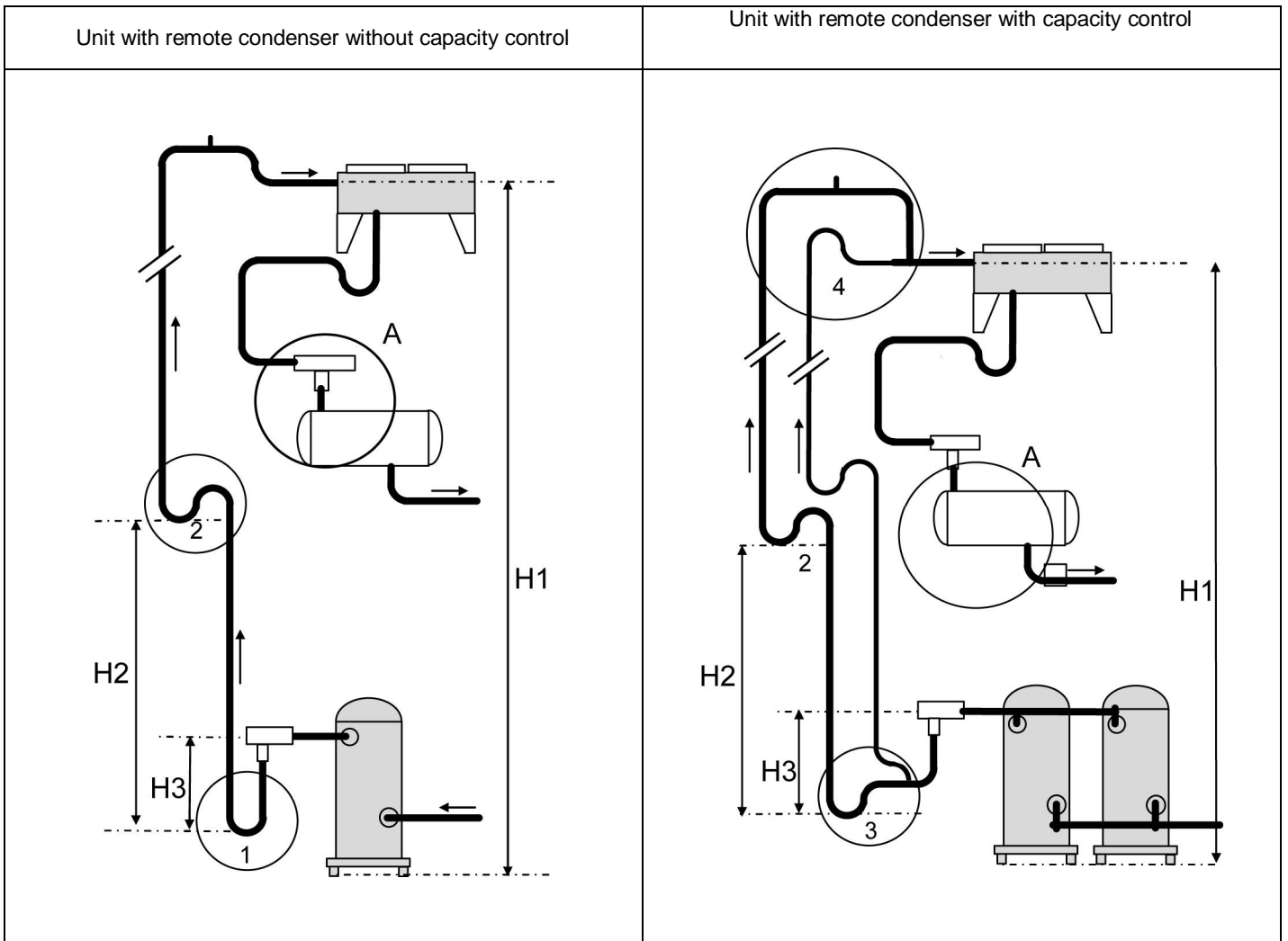

H1: 15 m. maxi
H2: 5 m. maxi
H3: 0,3 m. maxi
H4: 0,15 m. maxi

1 - Lower trap with single tube
2 - Close coupled trap
3 - Lower trap with double tubes
4 - Higher trap with double tubes

WARNING: The liquid level between the condenser and the check valve A must compensate the check valve pressure drop

Condensing Units

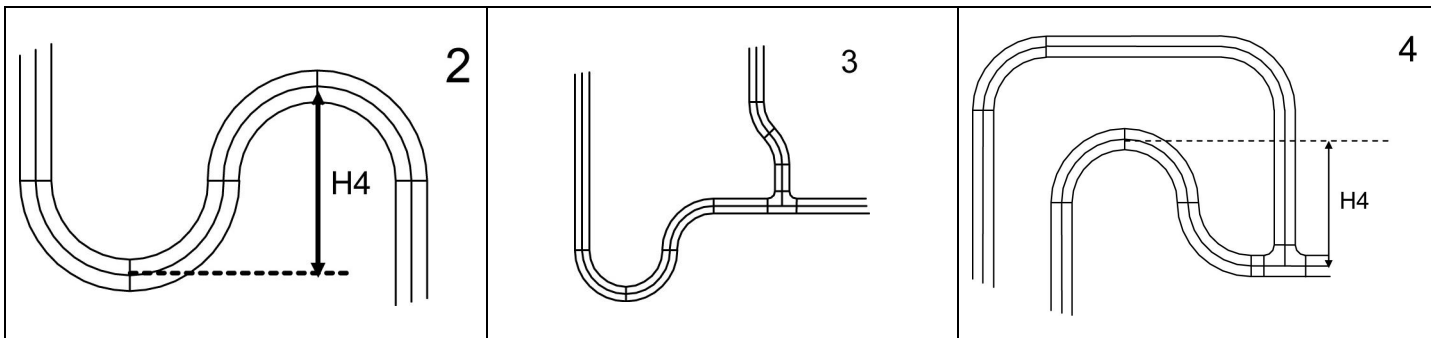
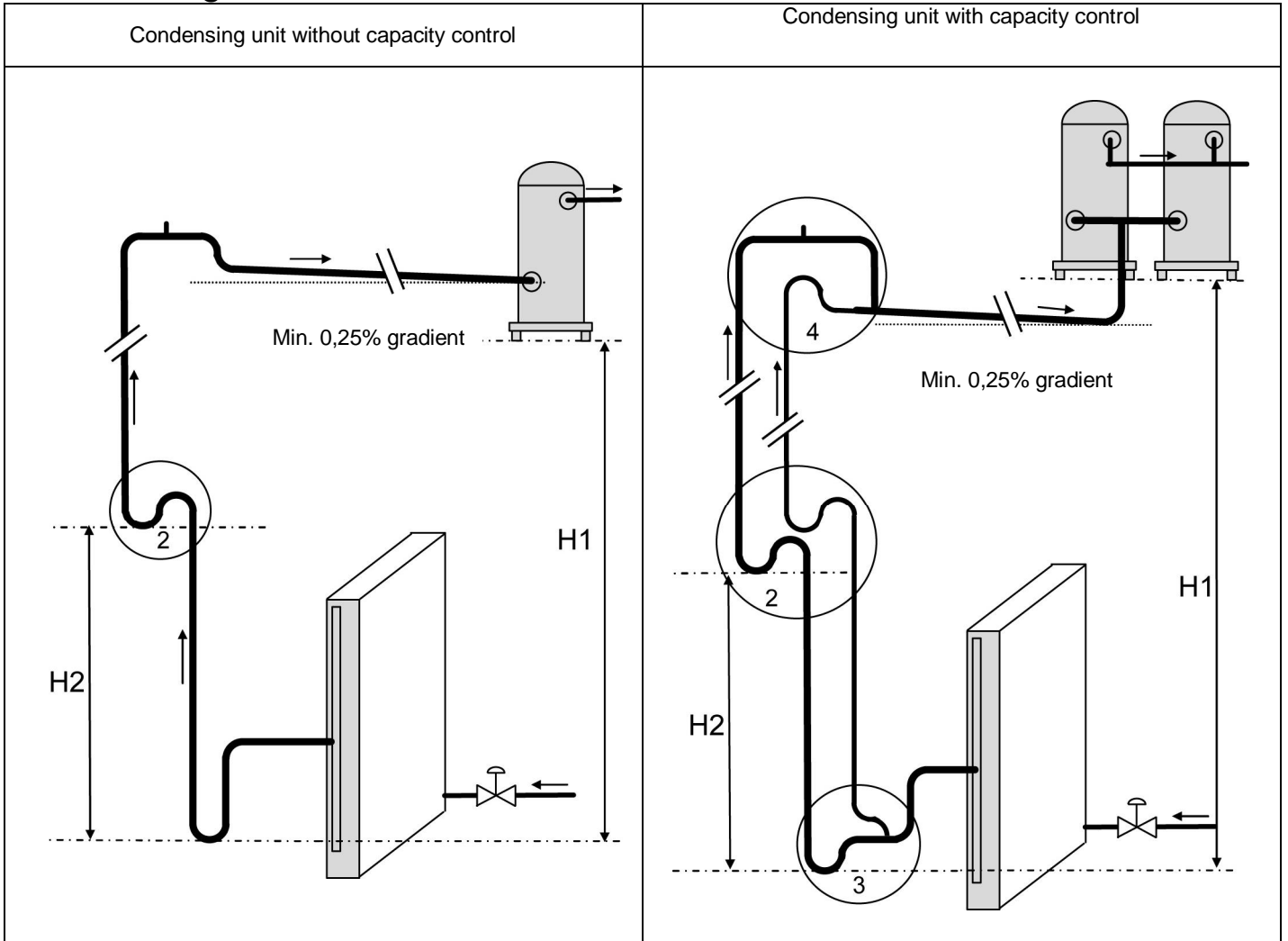

H1: 15 m. maxi
H2: 5 m. maxi
H4: 0,15 m. maxi

1 - Lower trap with single tube
2 - Close coupled trap
3 - Lower trap with double tubes
4 - Higher trap with double tubes

Minimum refrigeration capacity in kW for oil entrainments up Suction risers													
refrigerant R407C													
		Tubing Nominal OD, mm											
saturated temp °C	Suction gas temp °C	12	15	18	22	28	35	42	54	67	79	105	130
-5	0	0,39	0,71	1,20	2,04	3,88	6,88	11,11	21,31	36,85	55,86	115,24	199,30
	10	0,37	0,68	1,14	1,94	3,68	6,53	10,54	20,20	34,94	52,95	109,25	189,14
5	10	0,47	0,86	1,45	2,47	4,69	8,33	13,44	25,77	44,58	67,56	139,39	241,30
	20	0,44	0,81	1,36	2,31	4,39	7,79	12,58	24,13	41,73	63,25	130,49	225,90

Minimum refrigeration capacity in kW for oil entrainments up HOT-Gas risers													
refrigerant R407C													
		Tubing Nominal OD, mm											
saturated discharge temp °C	Discharge gas temp °C	12	15	18	22	28	35	42	54	67	79	105	130
30	70	0,60	1,09	1,84	3,13	5,95	10,55	17,03	32,65	56,47	85,59	176,59	305,70
	80	0,58	1,06	1,79	3,04	5,78	10,25	16,55	31,74	54,90	83,21	171,67	297,19
	90	0,57	1,04	1,74	2,96	5,64	10,00	16,14	30,95	53,53	81,13	167,39	289,77
40	80	0,62	1,13	1,90	3,24	6,16	10,93	17,65	33,85	58,55	88,73	183,07	316,92
	90	0,60	1,10	1,85	3,16	6,00	10,65	17,19	32,96	47,01	86,40	178,26	308,60
	100	0,58	1,07	1,80	3,07	5,83	10,34	16,70	32,02	55,38	83,94	173,17	299,79
50	90	0,63	1,16	1,94	3,31	6,29	11,16	18,02	34,55	59,77	90,58	186,88	323,52
	100	0,61	1,12	1,88	3,21	6,10	10,82	17,47	33,50	57,95	87,83	181,21	313,70
	110	0,60	1,09	1,83	3,13	5,94	10,54	17,02	32,63	56,44	85,53	176,47	305,49

3.7.3 - Mechanical isolation of refrigerant lines

Isolate refrigerant lines from the building to prevent the vibrations normally generated by the lines to the building structure. Avoid bypassing the isolation system on the unit by securing refrigerant lines or electrical conduits too tightly. Any vibrations will be transmitted to the building by rigid piping.

Lack of vibration isolation on refrigerant pipe work will lead to early failure of copper pipe and loss of gas.

3.7.4 - Pressure test

To avoid formation of copper oxide during brazing operations, blow a little dry nitrogen through the pipes. Piping must be made with tubing that is perfectly clean, plugged during storage and between connections operations.

During these operations, observe the following precautions:

- 1) Do not work in a confined atmosphere, refrigerant fluid can cause asphyxiation. Make sure there is sufficient ventilation.
- 2) Do not use oxygen or acetylene instead of refrigerant fluid and nitrogen for leak testing : this could cause a violent explosion.
- 3) Always use a regulator valve, isolating valves and a pressure gauge to control test pressure in the system. Excessive pressure can cause lines to burst damage to the unit and/or cause an explosion with severe personal injury.

Ensure conduct liquid line and gas line pressure tests are in conformity with applicable legislation. Before starting up a unit on a receiver, the piping and the condenser must be dehydrated. Dehydration should be carried out using a double stage vacuum pump, capable of drawing 600Pa absolute pressure vacuum. Best results are obtained with a vacuum down to 100 Pa.

To get down to this level at normal temperatures, i.e. 15 °C, it is often necessary to leave the pump running for 10 to 20 hours. The duration of pump operation is not a factor of efficiency. The pressure level must be checked before the unit is put into service.

3.7.5 - Refrigerant charge

Chillers with R407C must be filled in the liquid phase. Never charge a machine operating on R407C in the vapour phase (vapour): the composition of the mixture could be modified. In liquid phase, connect either to a liquid isolating valve, or to the quick-connector on the liquid line at the valve outlet.
 For unit using R22, the charging may be done in vapour phase in that case; connection will be made to the suction valve.

Note:

Splits units are supplied with a refrigerant or nitrogen holding charge. Before pulling down the vacuum for dehydration, completely purge the unit.

Charge the unit until there is a constant flow of bubble-free liquid in the sight-glass indicating that there is sufficient charge and controlled that sub cooling is correct according to the system design value.

In all cases, do not top up the charge until the unit reaches a stable state of operation.

It is pointless to overcharge a system, this can adversely affect operation.

Overcharging causes:

- Excessive discharge pressure,
- A risk of damage to the compressor,
- Excessive power consumption.

3.7.6 - Oil charge

All units are delivered with a complete oil charge. In the case of split units, it may be necessary, due to the length of piping installed, to add a certain amount of oil compatible with the type of compressor and refrigerant used.

Please refer to the following oil table.

Note: This table is valid for self-contained chillers only (or chillers mounted on receivers) on which the leaving water temperature is not lower than -5°C. For other cases, consult the documentation shipped with the machine.

Oil Recommendation for Lennox chillers

Refrigerant	Compressor Type	Brand	Oil Type
R407C	Screw CSH	Bitzer	BSE170
R407C	Scroll SZ	Maneurop	Maneurop 160SZ
R407C	Scroll ZR	Copeland	Copeland RL32-3MAF
R407C	Reciprocating D8	Copeland	Copeland RL32-3MAF
R407C	Reciprocating MSZ	Maneurop	Maneurop 300SZ

4 – PRELIMINARY CHECKS

Check that all drain and purge plugs are in place and well tightened prior to fill the installation with water.

4.1 - LIMITS

Prior to any operation, please check the operation limits of the unit given in the «APPENDIX» at the end of the IOM, These tables will give you all necessary information concerning the operating envelope of the unit.

Please consult the «Risk analysis and hazardous situations according to 97/123 directive» given in the «APPENDIX» at the end of the IOM, or supplied with the unit.

4.2 - REFRIGERATION CIRCUIT CHECKS AND RECOMMENDATIONS

In case of split units, check the installation has been made according to the recommendation described § Installation.

The unit refrigeration circuit sketch is given in the «APPENDICES» at the end of the IOM or supplied with the unit.

4.3 - INSTALLATION OF EXTERNAL HYDRAULIC COMPONENTS

Some hydraulic components may be supplied loose by Lennox:

Components supplied "loose" as an option

- 01 Kit For groove lock coupling
- 02 Evaporator water inlet filter
- 03 Condenser water inlet filter

Components supplied "loose" as standard

- 04 Paddle flow switch
- 05 Connection pipe for sensor
- A Inlet / Outlet Water temperature sensor

Components mounted inside the unit as Standard

- B Heat Exchangers

Refer to the "OPTIONS" section for information on connection and installation

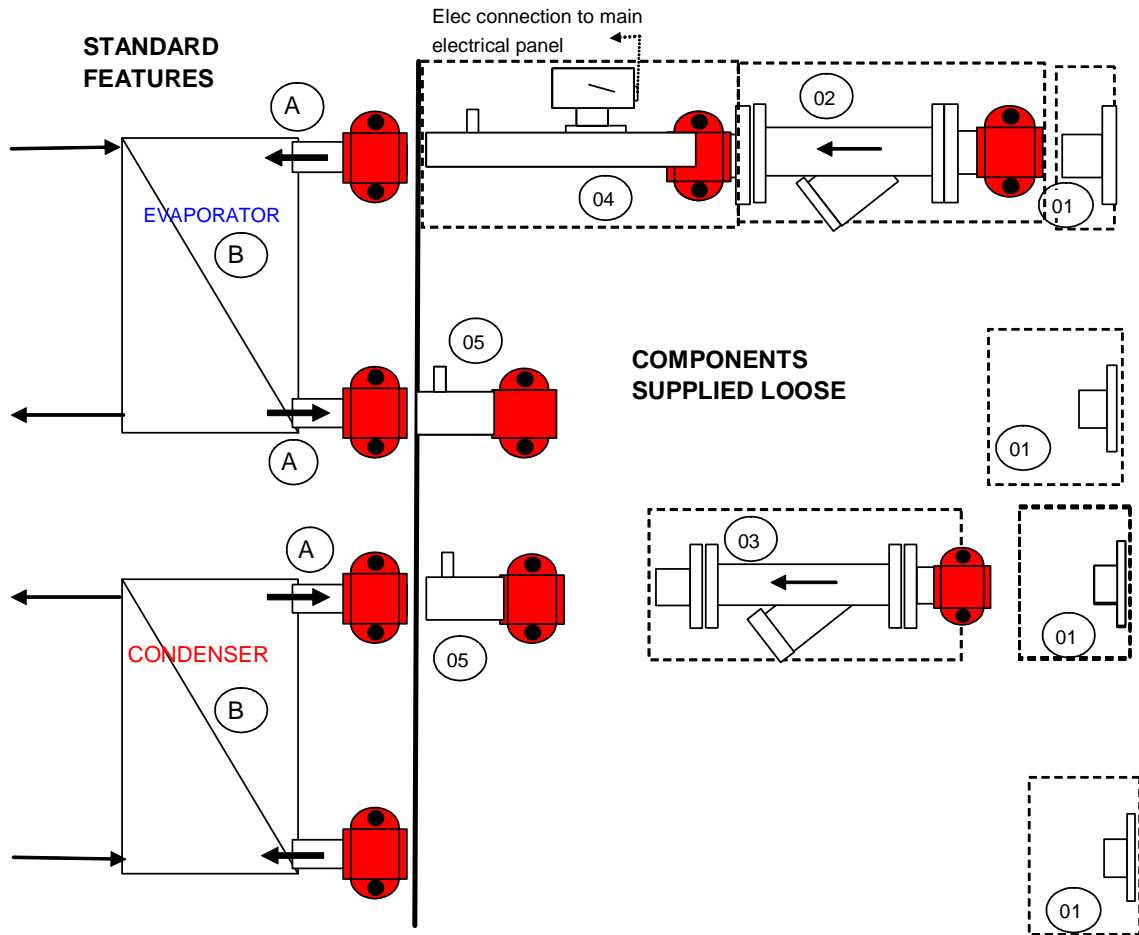



The components are located inside the units or in a separate box and must be installed by a qualified engineer.

Note: In case of plate heat exchangers it is mandatory that a filter is installed at exchanger unit entrance.

These filters must remove all particles with a diameter greater than 1 mm.

4.4 - CHECK LIST BEFORE START-UP

Before proceeding with start up, even for a test of short duration, check the following points, after having made sure that all the valves on the refrigeration circuit are fully open (discharge valves and liquid valves).

Starting up a compressor with the discharge valve closed will either trip the HP safety switch, or blow the cylinder head gasket or the internal pressure safety disc.

1) The liquid pump(s) and other apparatus interlocked with the unit (coils, air handling units, dry coolers, cooling towers, terminals such as fan coil units, etc.) are in working order as required by the installation and according to their own specific requirements.

Place all water valves and refrigerant valves in their operating positions and start the water circulating pumps. Ensure main power supply is isolated before any work is started. Ensure unit is correctly earthed and that earth continuity is correctly done.

Check that anti-vibration mountings are correctly installed and set.

2) **Check the cleanliness and the tightness of all electrical connections**, both the connections made at the factory and the connections made on site. Also make sure that all thermostat bulbs are correctly inserted and tightened in the various wells, if necessary add heat conducting paste to improve contact. Make sure all sensors are correctly fitted and that all capillary tubes are fastened. The technical data printed at the top of the wiring diagram should correspond with those indicated on the unit nameplate.

Make sure that the power supplied to the unit corresponds to its operating voltage and that **phase rotation corresponds to the direction of rotation of the compressors** (screw & scroll).

4) Ensure that the water circuits mentioned in 1 are completely filled with water or brine as the case may be; with the air bled out of all high points, including the evaporator ensuring they are perfectly clean and leak-tight. In the case of machines with water cooled condensers, the condenser water circuit must be ready to operate, filled with water, pressure tested, bled, filter cleaned after 2 hours of operation of the water pump. Cooling tower in operating condition, water supply and overflow checked, fan in operating condition.

5) Reset all manually resetting safety devices (where necessary).
Open power circuits to all components: compressors, fans....

6) Power up the unit with the main disconnect switch (option). Visually check the oil level in the compressor crankcases (bull's-eyes). This level may vary from one compressor to another, but should never be higher than the first third of the way up the bull's-eyes.



CAUTION: Power up the compressor crankcase heaters at least 24 hours before starting the unit. This will enable the refrigerant in the crankcases to evaporate off, and prevents damage to compressors through lack of lubrication during start up.

7) Start the pump(s) check the flow of liquid to be cooled through the heat exchangers: note the inlet and outlet water pressures, and, using the pressure drop curves, calculate liquid flow by applying the following formula:

Actual flow

$$Q = Q1 \times \sqrt{(P2/P1)}$$

Where

P2 = pressure drop measured on site

P1 = pressure drop published by LENNOX for a liquid flow of Q1

Q1 = nominal flow

Q = real flow

8) Before making any electrical connections, check that insulation resistance between power supply connection terminals is in keeping with applicable regulations. Check the insulation of all electrical motors using a DC 500V ohmmeter, following the manufacturer's instructions.

**CAUTION: Do not start any motor whose insulation resistance is lower than 2 Mega-ohms.
Never start any motor while the system is under a vacuum.**

5 – UNIT START-UP

5.1 - CHECKS TO BE MADE DURING START UP

Before starting the unit, fill in the check list sheet of this manual and follow the instructions below to be sure that the unit is correctly installed and ready to operate.

- 1) Thermometers and pressure switches installed in the chilled water circuit and the condenser water circuit. Check these safety devices in this order: high pressure switch, low pressure switch, fan control pressure switches and thermostats, anti short cycle relay. Make sure all indicator lights operate correctly.
- 2) Run evaporator pump prior to start the chiller.
- 3) Flow switch installed and wired into the control box operates properly.
- 4) Check that there is sufficient cooling load on the day the start up is conducted (at least 50 % of the nominal load).

PROCEDURE TO FOLLOW WHEN STARTING THE UNIT

4-a) Press the power “ON-OFF” switch. The compressor will only start if the evaporating pressure is greater than the cut-in set point of the low pressure switch. Check immediately the good rotation of the compressor.

Evaporating pressure drops steadily, the evaporator empties itself of the liquid refrigerant accumulated in it during storage. After a few seconds, the solenoid valve opens if any.

4-b) Check on the sight glass (upstream of the expansion valve if available) that the bubbles disappear progressively, indicating a correct refrigerant charge and without non condensable gas. If the humidity indicator changes colour, indicating the presence of humidity, replace the filter-drier cartridge if the latter is of the replaceable type. The best practice recommends checking the sub cooling after the condenser.

4-c) Check that, when the cooling load has been balanced by the capacity of the unit, the chilled liquid is at design temperature.

- 5) With the compressor running, check the oil pressure. If there is a fault, do not restart the compressor again until the source of the problem has been located.
- 6) Check the current values per phase on each compressor motor.
- 7) Check the current values per phase on each fan motor (If available)
- 8) Check compressor discharge temperature.
- 9) Check suction and discharge pressures and compressor suction and discharge temperatures.
- 10) Check chilled liquid entering and leaving temperatures.
- 11) Check condenser entering and leaving water temperatures.
- 12) Check outdoor air temperature in case of split units
- 13) Check liquid refrigerant temperature at the condenser outlet.

These verifications should be made as quickly as possible with a stable cooling load, i.e. the cooling load of the installation should be the same as the capacity developed by the unit. Measurements taken without heeding this condition will result in unusable and probably wrong values.

These verifications can only be made once the proper operation of all safety devices and unit controls has been established.

5.2 - OIL CHARGE

Units have a complete operating charge of oil when they are shipped, and there is no need to add any oil before start up or afterwards. Note that unit shutdowns by the differential oil pressure switch are usually caused by other problems than a lack of oil in the refrigeration circuits. Overcharging with oil can cause serious problems on an installation, particularly for the compressors. The only time any oil might need adding is when a compressor is replaced.

5.3 - REFRIGERANT CHARGE

Self-contained units have a complete refrigerant charge at the time they are shipped. This charge may need to be topped up when the unit is installed or at other times during the service life of the unit. Additional charge can be introduced through the Schrader valves on the suction line. Every time fluid is added, check the state of the charge with the sight glass if provided and also by the amount of liquid sub cooling at the condenser outlet.



IMPORTANT

- **Start up and commissioning must be conducted by LENNOX authorised engineer.**
- **Never shut of power to the crankcase heaters except for lengthy service operations or seasonal shutdown**

6 – OPERATION
6.1 – OPERATING LIMITS



WARNING: It is very important ensure the units operate well inside these envelopes.

6.1.1 –MCW all sizes

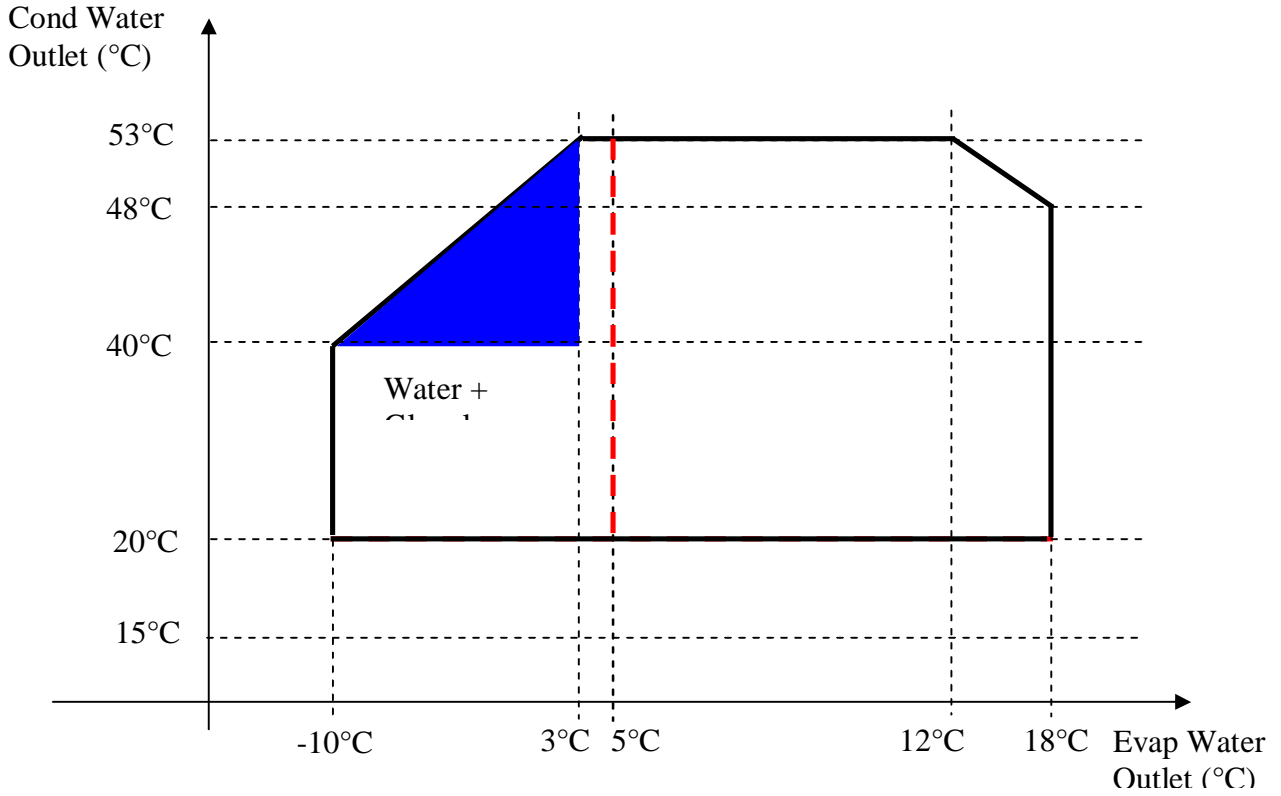

6.1.2 –MCSB WITH REMOTE CONDENSER (ALL SIZES)

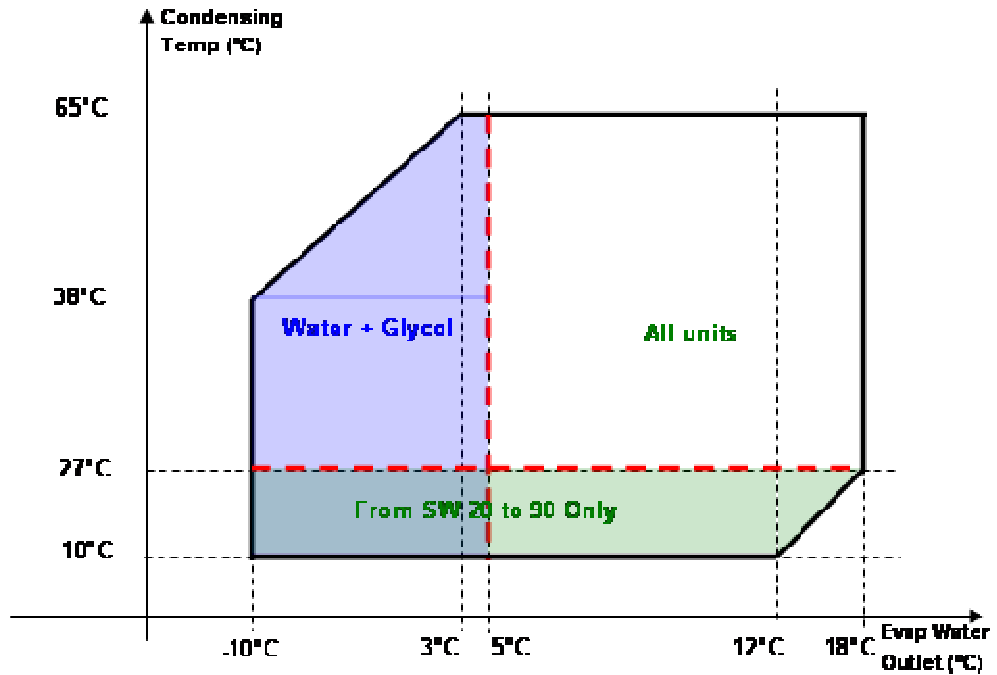

Indication on Pipe sizing for MCSB type units

	Discharge Lines		Liquid Lines	
	per circuit		per circuit	
	Mini Dia. Inches	Min / Max Speed	Mini Dia. Inches	Speed m/s
222	1" 5/8	10 / 15 m/s	1"1/8	0,5 / 1,5 m/s
262	1" 5/8	10 / 15 m/s	1"1/8	0,5 / 1,5 m/s
322	1" 5/8	10 / 15 m/s	1"3/8	0,5 / 1,5 m/s
422	2" 1/8	10 / 15 m/s	1"5/8	0,5 / 1,5 m/s

6.2 - UNIT OPERATION: REFRIGERATION CIRCUIT

6.2.1 – TANDEM SCROLL ASSEMBLIES

With “NEW” tandem assemblies the oil balancing is achieved through the use of a large two phase line tube.



It is **IMPERATIVE** that this tube is perfectly level during operation to ensure proper oil balancing between the two crankcases
 It is also **IMPERATIVE** for the compressor to be mounted on a rigid base frame as there is no flexibility in the oil equalizing line. The whole assembly can then be mounted on silencers.

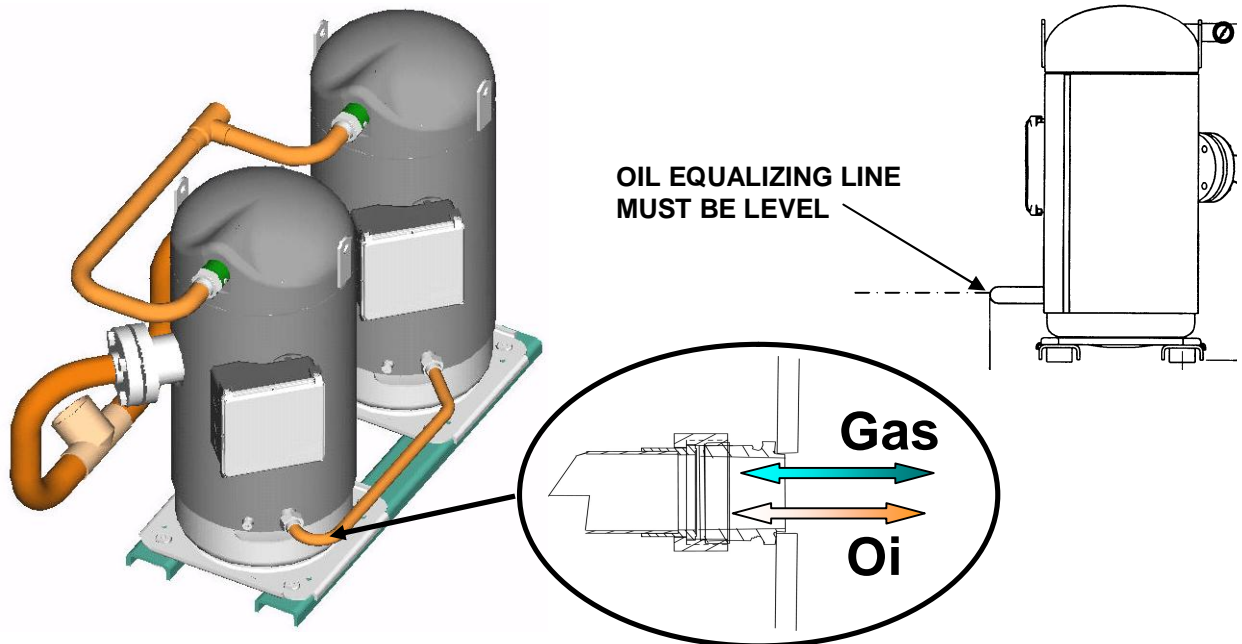

The oil equalizing Line is fitted with a sight glass which can be used to check the oil level in the compressor assembly. It is sometime better to stop both compressors to get a good reading of the oil level in the crankcase of the compressors.

There can be two types of tandem assemblies.

- EVEN TANDEM when both compressors are the same models
- UNEVEN TANDEM when compressors are different models

In the case of uneven tandem assemblies a restrictor is inserted in the suction of one of the two compressors.

The purpose of this restrictor is to equalize the suction pressure in order to ensure a better oil return to both compressors.

COMPRESSOR 1	COMPRESSOR 2	RESTRICTOR	RESTRICTOR REFERENCE	POSITION OF RESTRICTOR
ZR11	ZR11	NO		
ZR12	ZR12	NO		
ZR16	ZR16	NO		
ZR19	ZR19	NO		
ZR310	ZR310	NO		
ZR380	ZR380	NO		
ZR16	ZR310	YES	5110061 X	ZR16 Suction
ZR19	ZR380	YES	5110062 Y	ZR19 Suction
ZR310	ZR380	YES	5110063 Z	ZR310 Suction



WARNING: THE UNIT CAN NOT OPERATE WITHOUT A RESTRICTOR IF IT IS REQUIRED

6.2.2 – COPELAND SCROLL DISCHARGE TEMPERATURE PROTECTION (STANDARD)

If the oil in the compressor gets too hot it will start to deteriorate and lose its ability to lubricate, and will eventually cause a compressor failure. Lennox compressors are sometimes fitted with a specially designed sensor in the hottest part of the compression cycle, just above the discharge port of the scroll sets. This sensor is connected to the solid-state protection module in the terminal box. If the temperature rises above a pre-set value, the compressor will be shut down for **30 minutes before restarting the compressor**.

6.2.3 – THERMOSTATIC EXPANSION VALVE

The thermostatic expansion valve fitted on each machine has been selected for a given operating range; it must be replaced with a model with the same reference from the same manufacturer.

Very important:



The standard expansion valve fitted to the unit was selected for positive chiller water outlet temperatures

6.2.4 – FILTER DRIER (STANDARD):

This is designed to remove all traces of humidity from within the refrigeration circuit, since this can impair operation of the unit, by acidification of the oil, which causes slow disintegration of the varnish protecting the compressor motor windings.

Removable cartridge filter dryer on all units.

6.2.5 – HIGH AND LOW PRESSURE GAUGES (STD):

They enable an instantaneous readout of suction and discharge pressures.

Liquid filled gauges that measure the evaporating Low pressure (LP) and condensing high pressure (HP) on each refrigerant circuit. Gauges are “glycerine” filled to damp gas pulsation and are mounted externally. The gauges are compound gauges that display the saturated refrigerant temperature for the refrigerant R407C.



6.2.6- CRANKCASE HEATER (Standard)

Every compressor is fitted with a single phase crankcase heater that is activated when the compressor stops to ensure separation of the refrigerant and the compressor oil. It is also powered up when the compressor is not running.

6.2.7 – HIGH PRESSURE SWITCH (Standard)

This pressure switch initiates unconditional shut down of the unit if compressor discharge pressure exceeds the operating limits. Reset is automatic.

- Screw and reciprocating compressor with R407C high pressure switch equal 26.5 bars
- Scroll compressor with R407C high pressure switch equal 29 bars

On MCW, the High pressure switch is Auto reset. The controller will lock the fault preventing a new start up after three faults

6.3 - UNIT OPERATION: ELECTRICAL AND CONTROL FEATURES

cf. See the specific «CLIMATIC 50 controller» manual

6.3.1 – ANTIFREEZE PROTECTION (Standard):

This feature is provided as standard by the climatic controller: and can be adjusted for brine or glycol/water chilling for which the freezing temperature depends on the concentration of the solution.

The antifreeze protection provided causes an immediate shut down of the unit.

The controller monitors the chilled water outlet temperature and LP. It then triggers the fault if the LP goes below the antifreeze set point pressure (parameter 3421 only for units without glycol) or if the water outlet temperature drops below the minimum allowed chilled water outlet set point (parameter 3341)

6.3.2 – ANTI SHORT CYCLE PROTECTION (Standard):

This device limits the number of compressor start ups. It is a standard feature provided by the CL50 controller

6.3.3 – COMPRESSOR MOTOR OVER CURRENT PROTECTION (Standard):

Each compressor is fitted with independent circuit breaker designed to protect each motor winding against accidental over current.

6.3.4 – FLOW SWITCH FOR THE CHILLED WATER (Standard):

This control device is supplied loose as standard on all MCW and initiates unconditional unit shut down as soon as the flow of chilled liquid (water, brine, etc...) is too low.

On MCW units, a cable is provided to connect the external flow switch to the control panel.

If the user installs a flow switch himself, electrical connections should be made to the two remote interlock terminals (dry contact).

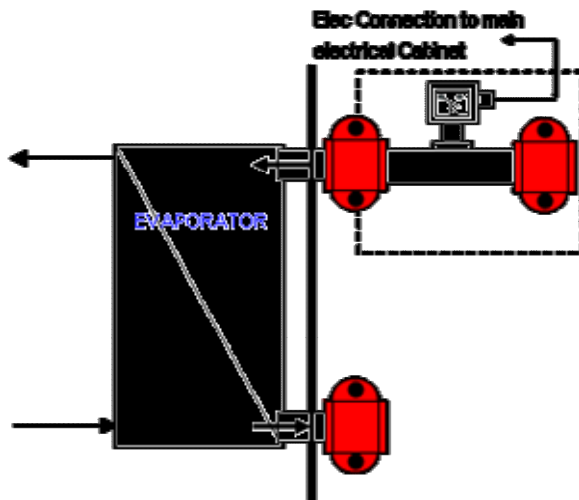

6.3.5 – HOT WATER CONTROL (OPTION)

This option can only be selected on request and consists in a special configuration of the program and temperatures probes fitted to the condenser



It is NOT recommended to use a Pressure Regulating Valve when the Control on Hot Water Option is selected

6.4 – OTHER FEATURES AND OPTIONS

6.4.1 – *Differential oil pressure safety switch: (only on units with semi-hermetic compressors)*

a) Reciprocating compressors:

This pressure switch initiates unconditional unit stoppage if differential oil pressure drops for more than two minutes below a pre-established minimum safety value.

Differential oil pressure is the difference between the oil pump discharge pressure and the gas pressure inside the compressor crankcase (suction pressure). The differential oil pressure safety switch is factory set and is not modifiable on site.

b) Screw compressors:

This pressure switch initiates unconditional unit stoppage if differential oil pressure rises above a preset safety value. Differential oil pressure in this case is high pressure less the compressor oil injection pressure.

6. 4.2 - *Loss of power supply:*

There are no problems restarting the machine after a loss of power supply of short duration (up to about one hour). If loss of power supply lasts longer than this, when power supply is resumed set the unit to «OFF» with the compressor crankcase heaters activated for as long as it takes to bring sump oil back up to temperature, then restart the unit.

7 – MAINTENANCE

The following maintenance instructions form a part of the operations required for this type of equipment. However, it is not possible to give fixed and precise rules for permanent maintenance procedures capable of keeping all units in perfect operating condition since too many factors depending on local conditions specific to the installation, the way the machine is operated, the frequency of operation, climatic conditions, atmospheric pollution, etc. Only trained experienced personnel can establish strict maintenance procedures adapted to the conditions listed above.

Nonetheless, we recommend a regular maintenance schedule:

- 4 times a year for chillers operating all year long
- 2 times a year for chiller that only operate during the cooling season

All operations must be performed in conformity with the maintenance plan; this will extend the service life of the unit and reduce the number of serious and costly breakdowns.

It is essential to keep a «service log», for weekly records of operating conditions of the machine. This log will serve as an excellent diagnostic tool for the maintenance team ; likewise, the machine operator, by noting down changes in machine operating conditions, will often be able to anticipate and avoid problems before they actually occur or worsen.

The manufacturer cannot be held responsible for any malfunctioning of any equipment it provides if it is caused by a lack of maintenance or by operating conditions beyond those recommended in this manual. Shown below, and as an illustration only, are some of the most common rules applied for maintenance.

7.1 WEEKLY MAINTENANCE

1) Check the compressor oil level. This should be half way up the sight glass with the machine running at full load. Let the compressor operate for 3 to 4 hours before adding any oil. Check the oil level every 30 minutes. If the level does not reach the level indicated above, contact a qualified refrigeration mechanic.

For uneven tandems and trios where the oil level sight glass is on the equalizing line, the control must be done after a complete stop of both compressors. The oil level should be half way up the sight glass.

2) Overcharging with oil can be as dangerous to a compressor as a lack of oil. Before topping up, contact a qualified technician. Only use oils recommended by the manufacturer.

3) Check the oil pressure for semi hermetic compressors.

4) The flow of liquid refrigerant through the sight glass should be steady and without bubbles. Bubbles are a sign of a low charge, a possible leak, or of a restriction in the liquid line. Contact a qualified technician. Each sight glass is fitted with a humidity indicator. The colour of the element changes according to the level of humidity in the refrigerant, but also according to temperature. It should indicate «dry refrigerant. If it shows «wet» or «CAUTION», contact a qualified refrigeration technician.

CAUTION: When starting up the unit, run the compressor for at least 2 hours before taking a humidity reading. The humidity detector is also sensitive to temperature, and as a consequence, the system must be at normal operating temperature to give a meaningful reading.

5) Check if the operating pressures are higher or lower than those recorded when the machine was put into service.

6) Inspect the entire system so as to detect any eventual abnormality: noisy compressor, loose casing panels, leaky pipes or juddering contacts.

7) Record temperatures, pressures, date and times and any other observations in the service log.

8) Leak detection is recommended.

7.2 ANNUAL MAINTENANCE

On units with water cooled condensers, it is important that the unit be serviced regularly by a qualified technician, at least once every year or every 1000 hours of operation. Failure to observe this rule can lead to cancellation of the warranty and will clear LENNOX of whatever responsibility.

A service visit by a qualified technician is also recommended after the first 500 hours of operation after the unit is first put into service.

- 1) Inspect valves and piping.
- 2) Clean the chilled water piping filters.

CAUTION: The chilled water circuit may be pressurised. Observe the usual precautions when depressurising the circuit before opening it. Failure to observe these rules could lead to accidents and cause injury to service personnel.

- 3) Clean any corroded surfaces and repaint them.
- 4) Inspect the chilled water circuit for any signs of leakage.
Check operation of the water circulating pump and its ancillaries.
Check the percentage of antifreeze in the chilled water circuit, top up as necessary (if antifreeze is used).

- 5) Carry out all weekly maintenance duties.

The first and last inspection will include the seasonal shutdown procedure or the restarting procedure depending on the case.

These inspections should include the following operations:

- Check the contacts of motor contactors and control devices.
- Check the adjustment and operation of each control device.
- Conduct an oil analysis to determine the acidity. Record the results.
- Change the oil if necessary.

WARNING: Oil analyses should be carried out by a qualified technician. Misinterpretation of the results could cause damage to the equipment.

Also, analysis operations should be conducted according to the right procedures, so as to avoid accidents and potential injury of service personnel.

- Follow the recommendations given by LENNOX as concerns compressor oil (see the appropriate table).
- Conduct a refrigerant leak test.
- Check motor winding isolation.

Other operations may be necessary depending on the age and the number of hours of operation of the installation.

7.3 CLEANING THE CONDENSER

7.3.1 Air cooled condensers

Clean the coils either with a vacuum cleaner, cold water, compressed air, or with a soft brush (non metallic). On units installed in a corrosive atmosphere, coil cleaning should be part of the regular maintenance program. On this type of installation, all dust gathered on the coils should be quickly removed by regular cleaning.

Caution: do not use high pressure cleaners that could cause permanent damage to the aluminium coil fins.

7.3.2 Shell and tube water cooled condensers

Use a cylindrical brush to remove sludge and other substances in suspension inside the condenser tubes. Use a non corrosive solvent to remove scale deposits.

The water circuit in the condenser is manufactured in steel and copper. A water treatment specialist, given the right information, will be able to recommend the right solvent for removing scale.

The equipment to be used for external water circulation, the quantity of solvent and the safety measures to be taken must be approved by the company supplying the cleaning products or by the company conducting these operations.

7.3.3 Plate heat exchanger condensers

Use a non corrosive solvent to remove scale deposits. The equipment to be used for external water circulation, the quantity of solvent and the safety measures to be taken must be approved by the company supplying the cleaning products or by the company conducting these operations.

7.4 COMPRESSORS / OIL DRAINAGE

Oil for refrigeration equipment is clear and transparent. It keeps its colour over a long period of operation. Given that a correctly designed and installed refrigeration system will operate without any problems, there is no need to replace the compressor oil even after a very long period of operation. Oil that has become dark in colour has been exposed to impurities in the refrigeration piping system or to excessive temperatures on the discharge side of the compressor, and this inevitably impairs the quality of the oil. Darkening of the colour of the oil or degradation of its qualities can also be caused by the presence of humidity in the system. When the oil has changed colour or has been degraded, it must be changed. In this event, before putting the unit back into service, the compressor and the refrigeration circuit will have to be evacuated.

7.5 IMPORTANT

Before proceeding with any service operations, make sure that the power supply to the unit is switched off. When the refrigeration circuit has been opened it will have to be evacuated, recharged, and inspected to ensure that it is perfectly clean (filter-drier) and leak tight. Remember that only trained and qualified personnel are authorised to operate on a refrigeration circuit. Regulations stipulate recovery of refrigerants and forbid wilful discharge of refrigerants into the atmosphere.

8 – TROUBLESHOOTING – REPAIRS

8.1 LIST OF THE MOST COMMON PROBLEMS

PROBLEMS – SYMPTOMS	PROBABLE CAUSE	RECOMMENDED ACTION
A) THE COMPRESSOR DOES NOT START		
- Motor control circuits established, the compressor does not run	- No power supply	- Check main power supply and switch positions
	- Compressor motor burnt out	- Replace
- The system does not start	- Breaker tripped or fuses blown	- Determine the cause. If the system is in running order, close the disconnect - Check condition of fuses
	- No water flow in the evaporator or condenser	- Measure flow, check the water pump and water circuitry and filters
	- Flow switch contacts open	- Find the cause of the trip out
		- Check circulation of liquid in the evaporator, and the condition of the flow switch
	- Anti short cycle relay action	- Wait until the anti short cycle time delay has expired
	- Faulty control thermostat	- Check for proper operation, set points, contacts
	- Oil pressure switch tripped	- Check the oil pressure switch and determine the cause of the trip out
	- Antifreeze thermostat or low pressure safety switch tripped	- Check evaporating pressure, the condition of the antifreeze thermostat and the low pressure safety switch
	- Compressor thermal protection relay tripped	- Check for proper operation of the relay
	- High pressure safety switch tripped	- Check the condensing pressure, and the condition of the high pressure safety switch
	- Low pressure safety switch trip out	- Check low pressure safety switch differential

PROBLEMS – SYMPTOMS	PROBABLE CAUSE	RECOMMENDED ACTION
B) THE COMPRESSOR DOES NOT START		
- Normal operation with too frequent starts and stoppages due to action of the low pressure safety switch. Bubbles in sight glass. Or, normal compressor operation, but the low pressure safety switch trips out and resets frequently	- Low refrigerant charge	- Check the charge through the Sight glass on the liquid line, carry out a leak test, then top up the refrigerant charge
- Suction pressure too low, Filter drier frozen up	- Filter-drier obstructed	- Check the state of the drier and replace the filter
	- Solenoid valve closed	- Check that the valve is operating properly
	- Expansion valve closed	- Check bulb and capillaries, operation of the valve
	- Compressor suction valve	- Check the filter
C) THE COMPRESSOR SHORT CYCLES ON HIGH PRESSURE SAFETY SWITCH TRIP OUT		
	- High pressure safety switch trip out	- Check high pressure safety switch differential
	- Low air/water flow in condenser or dirty condenser coil (poor heat exchange)	- Check that pumps are operating correctly or the state of cleanliness of the coils / check fan operation
	- Incondensable substances in the refrigeration circuit	- Bleed from circuit and top up the refrigerant charge. Note : it is not permitted to discharge refrigerant to atmosphere
D) THE COMPRESSOR RUNS IN LONG CYCLES OR RUNS CONTINUOUSLY		
	- Faulty control thermostat	- Check operation
- Temperature too low in the conditioned space	- Chilled water thermostat set too low	- Adjust it
- Bubbles in sight glass	- Low refrigerant charge	- Check the refrigerant charge in the sight glass and top up if necessary
	- Filter-drier partly obstructed	- Check the drier and replace as required, change the filter cartridge
	- Expansion valve partly closed	- Check expansion valve bulb and capillary, measure superheat
	- Liquid line valve not open far enough	- Open the valve completely
- Noisy compressor, or abnormally high suction pressure or low discharge pressure	- Leaky compressor valves	- Check valve gas-tightness; replace the valve plate if necessary. Tighten compressor nuts and bolts

PROBLEMS – SYMPTOMS	PROBABLE CAUSE	RECOMMENDED ACTION
E) THE COMPRESSOR CUTS OUT ON OIL PRESSURE SAFETY SWITCH		
	- Oil pressure switch tripped	- Check operation of the oil pressure safety switch
- Oil level in sight glass is too low -	- Oil pressure too low	- Check the oil level in the sight glass on the crankcase, check the cleanliness of the oil filter, check the oil pump
- Visible oil leak / Oil level too low	- Low oil charge	- Check that there is no leakage and add oil
	- Leaky oil sump	- Repair and add oil
- Suction line unusually cold, compressor noisy	- Liquid refrigerant present in the compressor crankcase	- Check appearance of the oil in the sight glass. Measure temperature of the oil pump, measure superheat at the expansion valve, check that the valve bulb is tightly attached
	- Poor heat exchange in the evaporator	- Check water flow. Check fouling by measuring the water pressure drop. Excessive oil migration in the circuit : measure evaporating pressure, superheat and the temperature of the oil pump
F) THE COMPRESSOR CUTS OUT ON ANTIFREEZE PRESSURE SWITCH		
	- Antifreeze pressure switch tripped	- Check that the pressure switch is operating properly
	- Low water flow in the evaporator	- Check the water pump
	- Evaporator obstructed	- Determine the degree of fouling by measuring water pressure drop
	- Evaporator frozen up	- Measure pressure drop in water circuit, keep water circulating until evaporator has thawed completely
	- Low refrigerant charge	- Check the refrigerant charge and add refrigerant if necessary

PROBLEMS – SYMPTOMS	PROBABLE CAUSE	RECOMMENDED ACTION
G) THE COMPRESSOR CUTS OUT ON ITS MOTOR PROTECTION THERMAL RELAY		
	- Thermal protection Tripped	- Check operation of thermal protection, change it if necessary
	- Motor windings are not being sufficiently cooled	- Measure superheat in the evaporator, adjust it if necessary
H) COMPRESSOR CUTS OUT THROUGH ACTION OF THE MAIN POWER FUSE		
	- Power supply on two phases only	- Check power supply voltage
	- Faulty motor windings	- Replace the compressor
	- Compressor seized	- Replace the compressor
I) THE COMPRESSOR STARTS WITH DIFFICULTY		
	- Faulty windings	- Replace the compressor
	- Mechanical problem	- Replace the compressor
J) THE COMPRESSOR IS NOISY		
	- If starting on a single winding on compressors fitted with part winding start or star-delta	- Check operation of the starter contacts, the start up time delay and the condition of the windings
- Compressor knocking	- Broken mechanical parts inside compressor	- Replace the compressor
- Suction line is unusually cold	a) Liquid slugging	a) Check superheat and that the expansion valve bulb is correctly installed
	b) Liquid slugging	b) Repair or replace
	- Broken suction valves	- Replace broken valves
- High discharge pressure. The water regulating valve or the pressure operated water valve taps or knocks	- Pressure operated water valve fouled, water pressure is too high or irregular	- Clean the valve. Install and expansion tank upstream of the valve
- Compressor shuts down through action of the oil pressure safety switch	- Low oil charge	- Add oil

PROBLEMS – SYMPTOMS	PROBABLE CAUSE	RECOMMENDED ACTION
K) DISCHARGE PRESSURE TOO HIGH		
- Water is far too hot at condenser outlet	- Water flow too low or water temperature too high in the condenser	- Adjust the pressure operated water valve or the thermostat on the cooling tower
- Water is far too cold at the condenser outlet	- Condenser tubes fouled	- Clean the tubes
- Condenser abnormally hot	- Presence of air or incondensibles in the circuit, or excessive refrigerant charge	- Purge incondensibles and/or air, and recover excess refrigerant
- Chilled water leaving temperature too high	- Excessive cooling load	- Reduce load, reduce water flow if necessary
L) DISCHARGE PRESSURE IS TOO LOW		
- Water is very cold at condenser outlet	- Condenser water flow too high or water temperature is too low	- Adjust the pressure operated water valve or the thermostat on the cooling tower
- Bubbles in sight glass	- Low refrigerant charge	- Repair the leak and add refrigerant
M) SUCTION PRESSURE IS TOO HIGH		
- The compressor runs continuously	- Too much cooling demand on the evaporator	
- Suction line unusually cold. Liquid refrigerant returns to compressor	a) Expansion valve opened too far	a) Adjust superheat and check that the expansion valve bulb is correctly fitted in place
	b) Expansion valve blocked in open position	b) Repair or replace
N) SUCTION PRESSURE IS TOO LOW		
- Bubbles in sight glass	- Low refrigerant charge	- Repair the leak and add refrigerant
- Excessive pressure drop across the filter-drier or the solenoid valve	- Filter-drier obstructed	- Replace the cartridge
- No refrigerant passing through the expansion valve	- Expansion valve bulb has lost its charge.	- Replace the bulb
- Loss of capacity	- Expansion valve obstructed	- Clean or replace
- Conditioned space too cold	- Control thermostat contacts stuck in closed position	- repair or replace
- Compressor short-cycling	- Capacity modulation setting too low	- Adjust
- Superheat value too high	- Excessive pressure drop in the evaporator	- Check the external equalizing line on the expansion valve
- Low pressure drop in the evaporator	- Low water flow	- Check water flow. Check the condition of the filters, look for obstructions in the chilled water circuit piping

8.2 CONTROL DEVICES

Operation

By reacting to compressor discharge pressure, the high pressure switch monitors efficiency of the condenser. Poor efficiency, the result of an excessive condensing pressure, is usually caused by :

- A dirty condenser
- Low water flow
- Low air flow

The low pressure switch monitors the pressure at which the refrigerant evaporates in the evaporator tubes.

Low evaporating pressure is usually caused by:

- Low refrigerant charge
- A faulty expansion valve
- An obstructed liquid line filter-drier
- A damaged compressor cylinder bank unloaded.

The control thermostat monitors chilled water temperature at the evaporator inlet. The most common causes of abnormal temperatures in this zone are:

- Low water flow
- Thermostat setting too low

The oil pressure switch monitors oil injection pressure on the compressor.

Low oil pressure is usually caused by:

- Low oil charge
- A worn or faulty oil pump
- A defective crankcase heater, causing condensation of refrigerant in the oil sump.

The above information does not represent a complete analysis of the refrigeration system. It is intended to familiarise the operator with unit operation and to provide him with the technical data required to enable him to recognise, correct or report a fault.



Only trained and qualified personnel is authorised to service and maintain this equipment.

8.3 REGULAR CHECKS TO BE MADE - CHILLER UNIT ENVIRONMENT

CHILLED WATER CIRCUIT VALUE

- Inlet / Outlet pressure gauges for pressure drop kPa
- Evaporator inlet temperature °C
- Evaporator outlet temperature °C
- Glycol concentration (1) %
- Flow switch operational at % débit
- Chilled water pump interlock []
- Filter on water circuit []

CONDENSER WATER CIRCUIT

- Inlet / Outlet pressure gauges for pressure drop kPa
- Condenser inlet temperature °C
- Condenser outlet temperature °C
- Regulation on condenser water inlet []
- Condenser pump interlock []
- Filter on water circuit []
- Unrestricted air flow on condenser coils (2) []

ELECTRICAL POWER SUPPLY

- Control circuit voltage V
- Power circuit power supply voltage L1/L2 V
- Power circuit power supply voltage L2/L3 V
- Power circuit power supply voltage L3/L1 V

(1) Depending on the application
 (2) According to the type of unit

8.4 MANUFACTURER’S RECOMMENDED INSPECTIONS

8.4.1 - LIQUID CHILLERS WITH RECIPROCATING COMPRESSOR(S)

8.4.1.1 - Number of recommended preventive maintenance visit:

NUMBER OF RECOMMENDED PREVENTIVE MAINTENANCE VISITS

Year	Start up	500/1000H visit	Major technical inspection	Inspection visit	15 000 h inspection	30000 h inspection	Tube analysis	
1	1	1		2				
2			1	3				
3			1	3				
4				3	1			
5			1	3			1 ⁽¹⁾	
6			1	3				
7				3		1		
8			1	3				
9			1	3				
10				3		1		1
+10					Every year	3 times a year	Every 15000 hours	Every 30000 hours

This table is published for units operating under normal conditions with an average annual runtime of 4000 hours.

In hostile industrial environments, a specific maintenance visit schedule must be planned.

(1) Depending on the quality of the water

8.4.1.2 - Description of inspection duties - Liquid chiller with reciprocating compressor(s)

START UP

- Check unit installation
- Check water flow and water circuit ancillaries
- Check safety devices
- Check leak tightness
- Configuration of the microprocessor based management system (if used)
- Verification of operating parameters and unit performance
- Transmission of the machine service log

500 H / 1000 H VISITS

- Post wear in inspection
- Oil acidity test, leak test
- Replacement of the filter-drier cartridges depending on the results of the test above.
- Monitor unit performance and any eventual variations linked to use of the installation.

INSPECTION VISIT

- Leak test
- Operating test with record of measurements taken and functional analysis.

MAJOR TECHNICAL INSPECTION

- Inspection visit
- Acid test
- Oil change if necessary
- Replacement of filter-drier cartridges if necessary
- Check up on the microprocessor based management system (if used)
- Adjustment of safety devices
- Verification of unit interlocks
- Lubrication of bearings / dampers if necessary

15 000 H VISIT

- Major technical inspection
- Inspection of the compressor and replacement of valves, springs and seals (depending on the type of compressor).

30 000 H VISIT

- Major technical inspection
- Inspection of the compressors with replacement of the valves, springs, seals and gaskets, bearings, oil discharge valve, piston rings.
- Dimensional inspection of the big ends and dudgeon pins, replacement of parts as required (quotation) (depending on the type of compressor).

TUBE ANALYSIS

- Inspection of water cooled evaporator and condenser tube bundles with an eddy current test to enable potentially serious problems to be anticipated.
- Frequency: Every 5 years up to 10 years (depending on the quality of water), then every 3 years.

8.4.2 - LIQUID CHILLERS WITH SCROLL COMPRESSOR(S)

8.4.2.1 - Number of recommended preventive maintenance visits :

NUMBER OF RECOMMENDED PREVENTIVE MAINTENANCE VISITS

Year	Start up	500/1000H visit	Major technical inspection	Inspection visit	Tube analysis
1	1	1		2	
2			1	3	
3			1	3	
4				3	
5			1	3	1 ⁽¹⁾
6			1	3	
7			1	3	
8			1	3	
9			1	3	
10			1	3	1
+10					Every year

This table is published for units operating under normal conditions with an average annual runtime of 4000 hours.

In hostile industrial environments, a specific maintenance visit schedule must be planned.

(1) Depending on the quality of the water

8.4.2.2 - Description of inspection duties - Liquid chiller with scroll compressor(s)

START UP

- Check unit installation
- Check water flow and water circuit ancillaries
- Check safety devices
- Check leak tightness
- Configuration of the microprocessor based management system (if used)
- Verification of operating parameters and unit performance
- Transmission of the machine service log

500 H / 1000 H VISITS

- Post wear in inspection
- Oil acidity test, leak test
- Replacement of the filter-drier cartridges depending on the results of the test above.
- Monitor unit performance and any eventual variations linked to use of the installation.

INSPECTION VISIT

- Leak test
- Operating test with record of measurements taken and functional analysis.

MAJOR TECHNICAL INSPECTION

- Inspection visit
- Acid test
- Oil change if necessary
- Replacement of filter-drier cartridges
- Check up on the microprocessor based management system (if used)
- Adjustment of safety devices
- Verification of unit interlocks
- Lubrication of bearings / dampers if necessary

TUBE ANALYSIS

- Inspection of water cooled evaporator and condenser tube bundles with an eddy current test to enable potentially serious problems to be anticipated.
- Frequency: Every 5 years up to 10 years (depending on the quality of water), then every 3 years.

8.4.3 - LIQUID CHILLERS WITH SCREW COMPRESSOR(S)

8.4.3.1 - Number of recommended preventive maintenance visits :

NUMBER OF RECOMMENDED PREVENTIVE MAINTENANCE VISITS

Year	Start up	500/1000H visit	Major technical inspection	Inspection visit	Tube analysis
1	1	1		2	
2			1	3	
3			1	3	
4				3	
5			1	3	1 ⁽¹⁾
6			1	3	
7			1	3	
8			1	3	
9			1	3	
10			1	3	1
+10					Every year

This table is published for units operating under normal conditions with an average annual runtime of 4000 hours.

In hostile industrial environments, a specific maintenance visit schedule must be planned.

(1) Depending on the quality of the water

8.4.3.2 - Description of inspection duties - Liquid chiller with screw compressor(s)

START UP

- Check unit installation
- Check water flow and water circuit ancillaries
- Check safety devices
- Check leak tightness
- Configuration of the microprocessor based management system
- Verification of operating parameters and unit performance
- Transmission of the machine service log

500 H / 1000 H VISITS

- Post wear in inspection
- Oil acidity test, leak test
- Replacement of the filter-drier cartridges depending on the results of the test above.
- Monitor unit performance and any eventual variations linked to use of the installation.

INSPECTION VISIT

- Leak test
- Operating test with record of measurements taken and functional analysis.

MAJOR TECHNICAL INSPECTION

- Inspection visit
- Acid test
- Oil change if necessary
- Replacement of filter-drier cartridges
- Check up on the microprocessor based management system
- Adjustment of safety devices
- Verification of unit interlocks
- Lubrication of bearings / dampers if necessary

30000 H VISIT

- Replacement of the compressor and return the old one for revision with replacement of bearing and inspection of compressor geometry
- Major technical inspection
- Start-up of the installation again

TUBE ANALYSIS

- Inspection of water cooled evaporator and condenser tube bundles with an eddy current test to enable potentially serious problems to be anticipated.
- Frequency: Every 5 years up to 10 years (depending on the quality of water), then every 3 years.

Machine identifications :	
Year of manufacture :	

NORMAL CONDITIONS OF USE

Leaving chilled water temperature : °C
Outdoor air temperature :	Max : °C
Power supply voltage :V/Ph/Hz
Refrigerant type :	
Date and time measurements were taken :	
Outdoor air temperature : °C
Company responsible for measurements :	
Name of technician :	
Remarks :

		Circuit 1			Circuit 2			Circuit 3	Circuit 4
		Compr. 1	Compr. 2	Compr. 3	Compr. 1	Compr. 2	Compr. 3	Compr. 1	Compr. 1
Number of hours of operation									
Compressors in service per circuit									
Evaporating pressure	Bar								
Suction piping temperature	°C								
Condensing pressure	Bar								
Discharge piping temperature	°C								
Oil pump temperature	°C								
Oil pressure	Bar								
Oil level	A								
Current on phase 1 per compressor	A								
Current on phase 2 per compressor	A								
Current on phase 3 per compressor	°C								
Liquid line temperature	Bar								
Evaporator pressure drop	°C								
Chilled water temperature	°C								
Leaving chilled water temperature	Bar								
Condenser pressure drop	°C								
Condenser entering water	°C								
Condenser leaving water	Bar								
H.P. pressure switch cut-out	Bar								
H.P. pressure switch cut-in	Bar								
Low pressure switch cut-in	Bar								
Oil pressure switch cut-out	Bar								
Antifreeze pressure switch cut-out	Bar								

Fan pressure switch 1 : (cut-out / bar)	Fan 2 :	Fan 3 :	Fan 4 :
--------------------------------------------	---------	---------	---------

This check list should be filled in by the contractor to make sure that unit installation takes place according to appropriate industry practices.

WARNING: Disconnect the power supply before carrying out any inspections on the unit. If the unit must be left powered up, proceed with precaution to avoid risk of electrocution.

Note: some units have a separate control circuit supply that is not isolated when the main power supply is OFF. This must be isolated separately.

RECEPTION

- Check absence of transport damage
- Check for missing items
- Availability of suitable lifting gear, slings and spacers

UNIT INSTALLATION

- Shipping crate removed
- Clearances checked
- Vibration isolators mounted
- Unit set in place
- Unit levelled

CHILLED WATER CIRCUIT

- All piping checked for leakage
- Thermometers installed
- Water pressure regulator installed
- Balancing valves installed
- Flow switch installed
- System rinsed, cleaned and filled before being connected to the unit. Check presence of filter on unit inlet and state of cleanliness of the filter.
- Checked operation of the pump and evaporator pressure drop

CONDENSER WATER CIRCUIT

- Checked order of power supply phases for scroll and screw compressor units
- All piping checked for leakage
- Thermometers installed
- Water pressure regulator installed
- System balancing valves installed
- System rinsed, cleaned and filled before being connected to the unit. Check presence of filter on unit inlet and state of cleanliness of the filter.
- Checked operation of the pump and condenser pressure drop

ELECTRICAL EQUIPMENT

- Check the main power supply matches the unit data plate.
- Check that the unit is correctly earthed
- Checked order of power supply phases for scroll and screw compressor units
- Checked correct direction of rotation of fan motors and proper operation of the latter.
- Direction of rotation of pump correct
- Control cabinet wired up.
- Power supply conforms with unit nameplate indications
- Pump starter and flow switch circuits complete and in working order
- Pipe heaters installed on all piping exposed to freezing temperatures
- All unions tightened with a torque wrench

GENERAL

- Cooling load available, minimum 50 %
- Coordination between different professions for final commissioning

CUSTOMER ORDER NUMBER: LENNOX REFERENCE:

DESIGNATION:

COMMENTS:

NAME: SIGNATURE:

APPENDICES

082

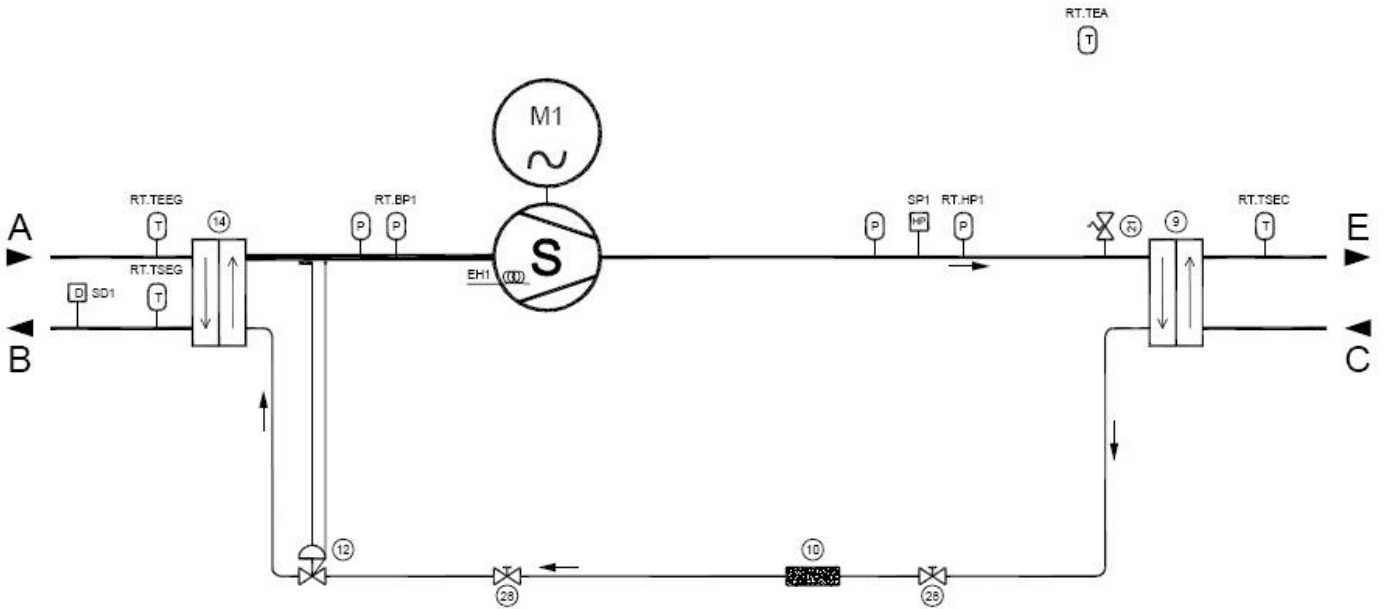

112-132-162-222-262-322

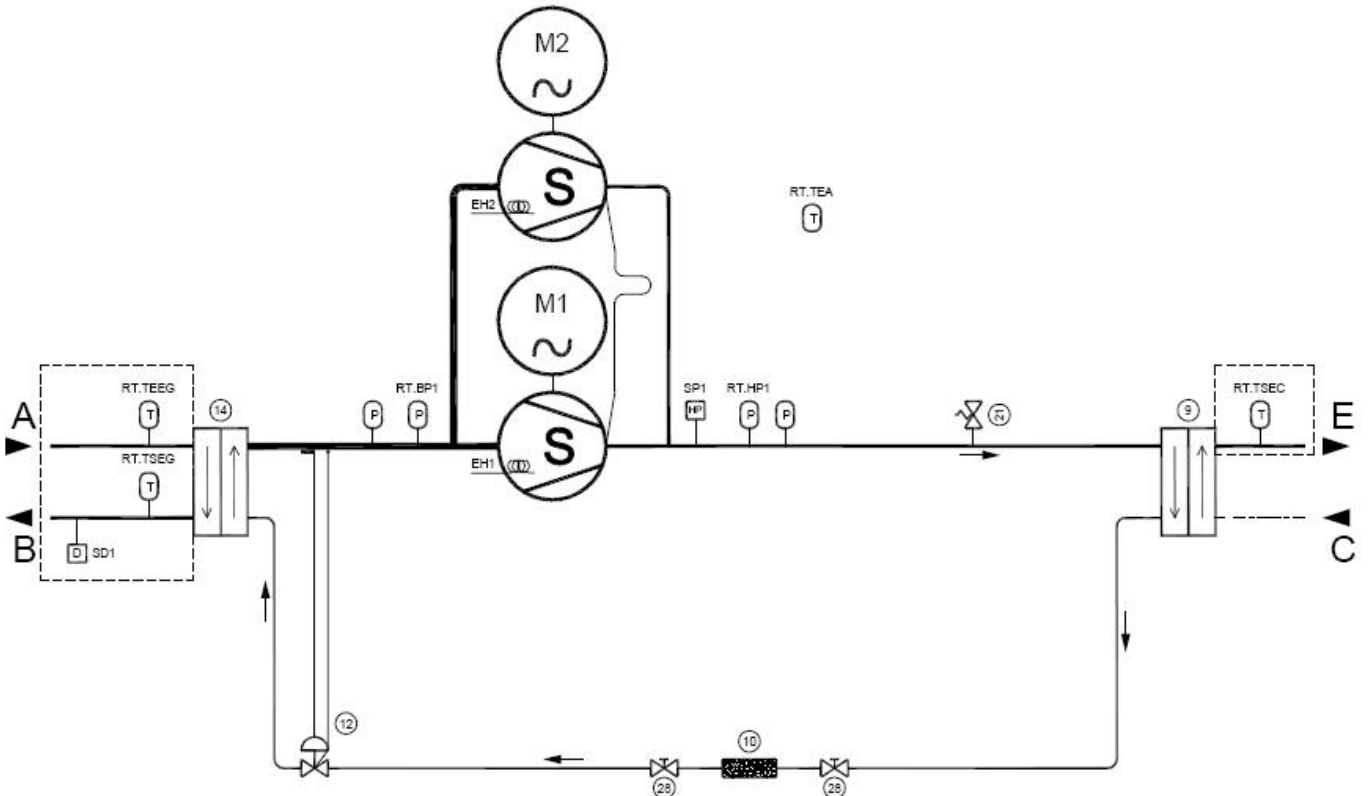

422

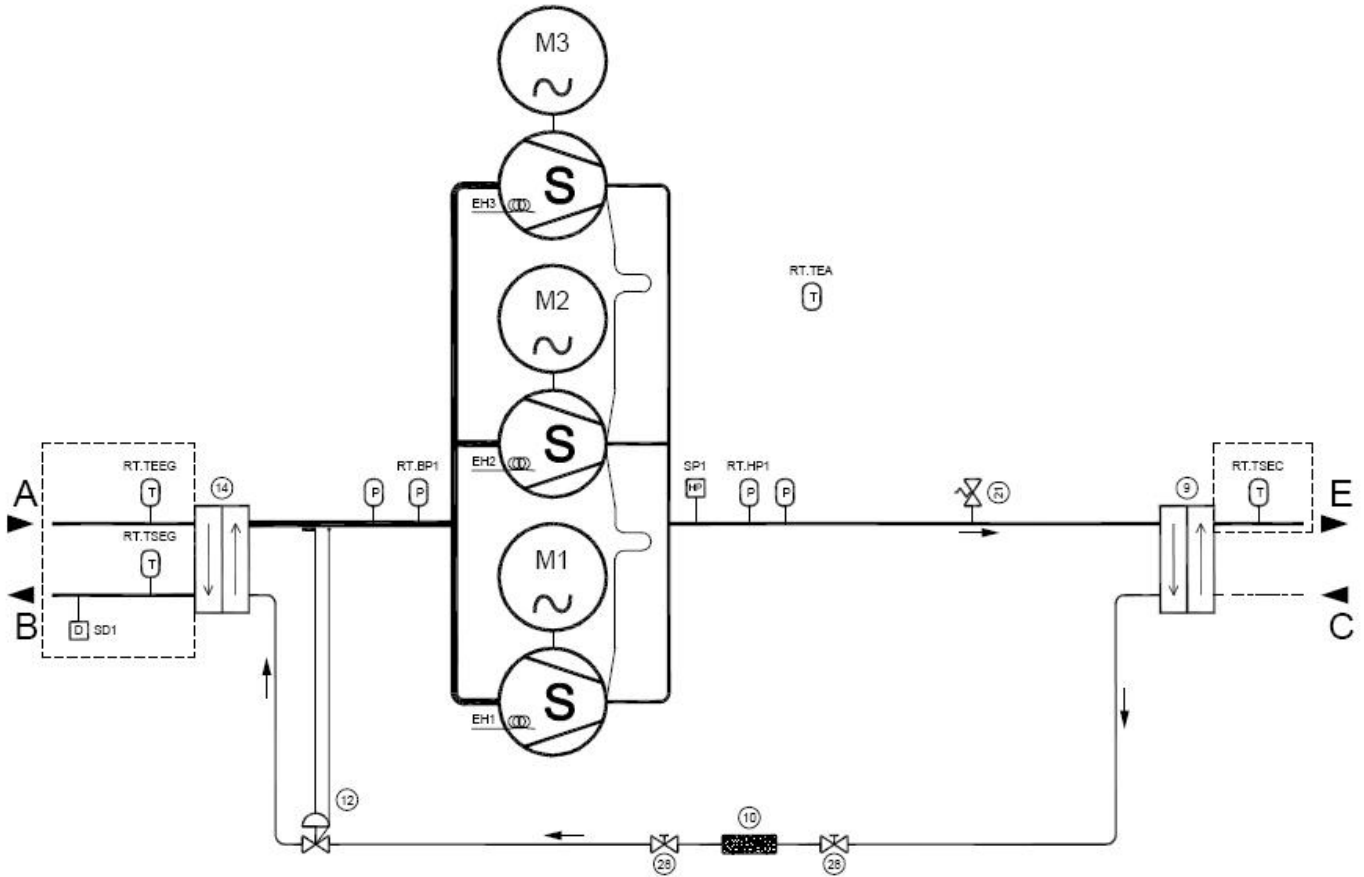

Standard Components		Options	
M1/ M2/ M3	Compressors	P	Low & high pressure gauges
14	Evaporator	28	Valves
9	Condenser	P RT	Low & high pressure sensors
12	Thermostatic expansion valve		
10	Filter drier		
HP SP	High pressure switch		

222-262-322

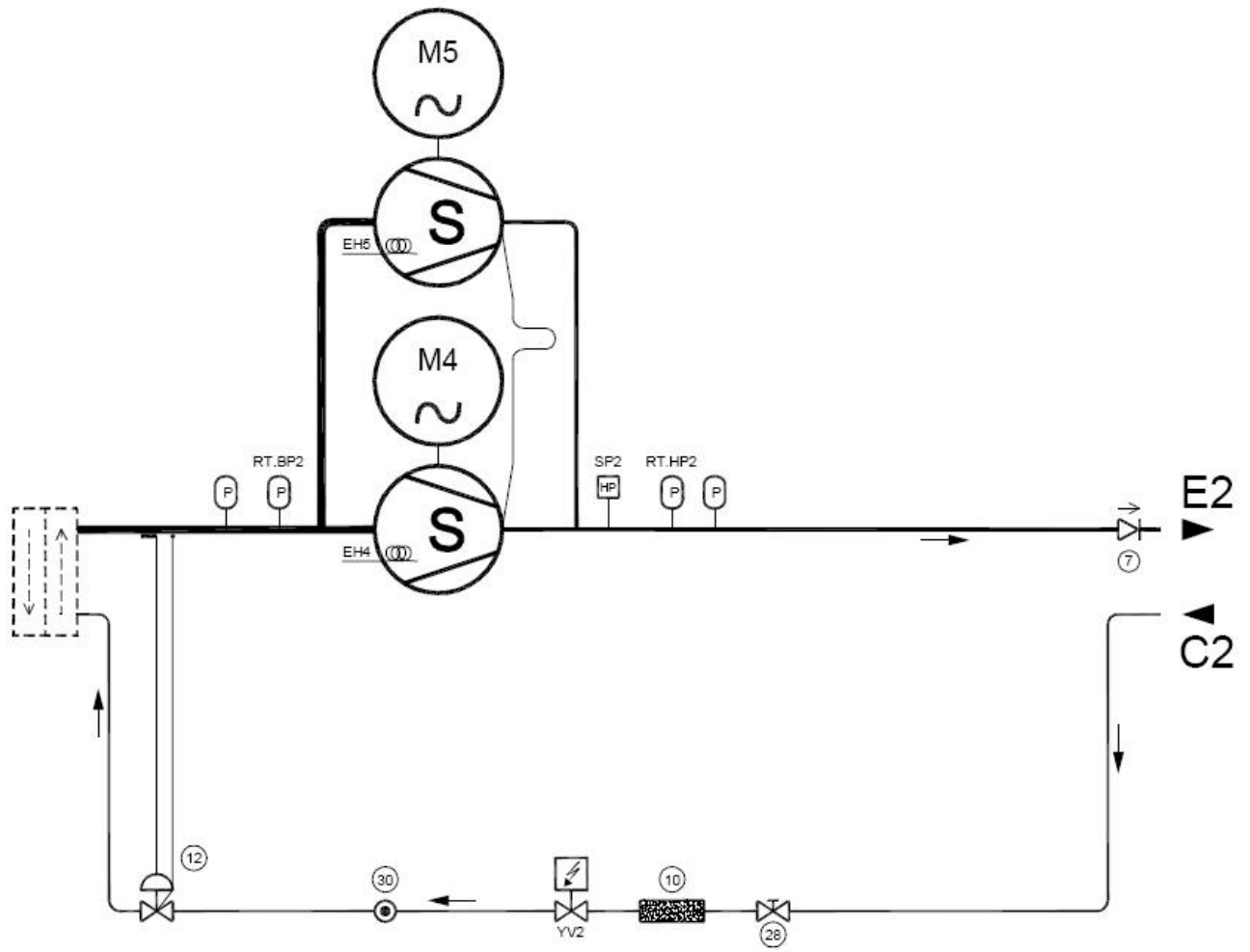

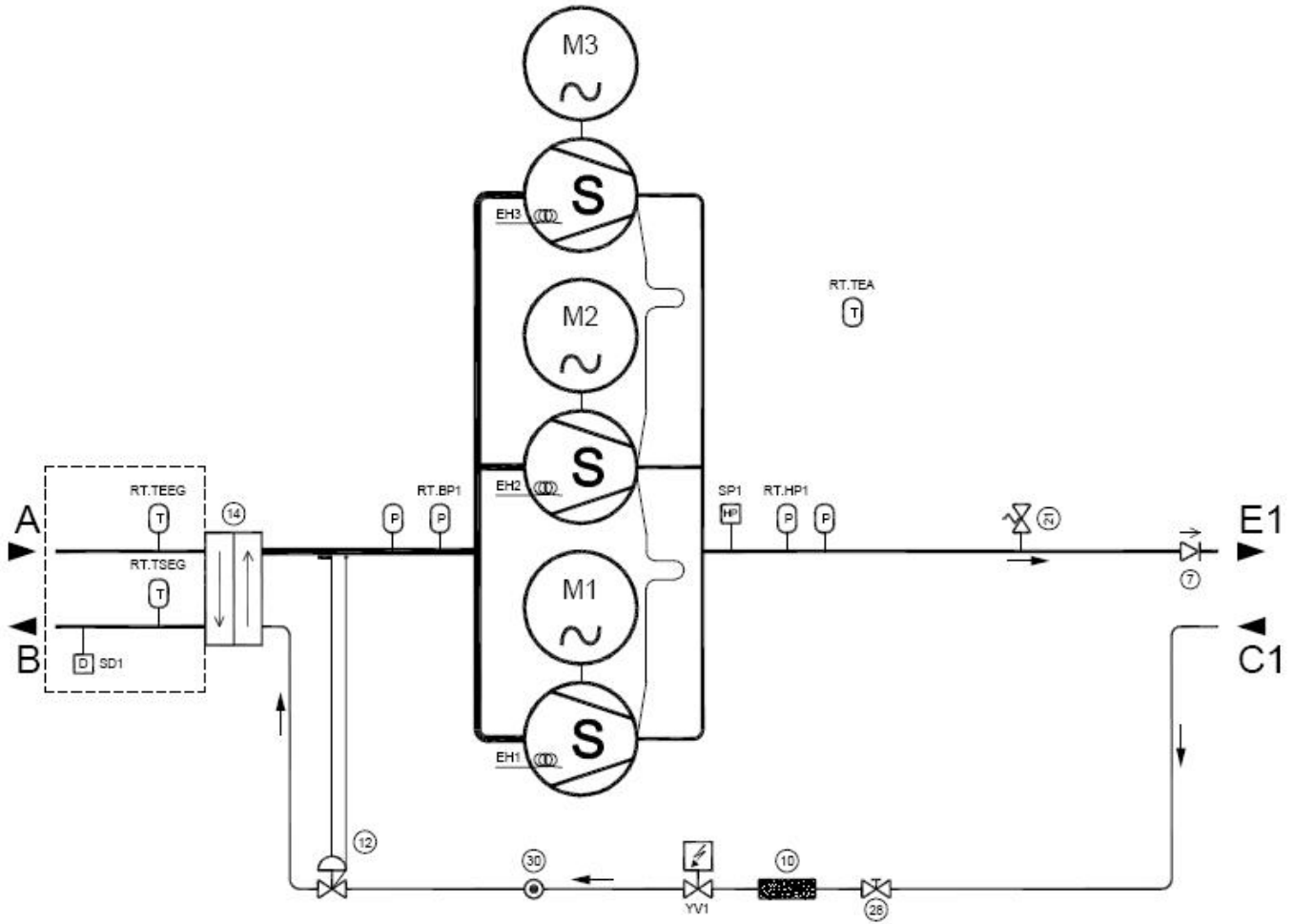

422

Standard Components		Options	
M1/ M2/ M3	Compressors	P	Low & high pressure gauges
14	Evaporator	28	Valves
7	Check valve	P RT	Low & high pressure sensors
12	Thermostatic expansion valve	30	Sight glass
10	Filter drier	YV	Electrical valve
HP SP	High pressure switch		

MCW 82 SK

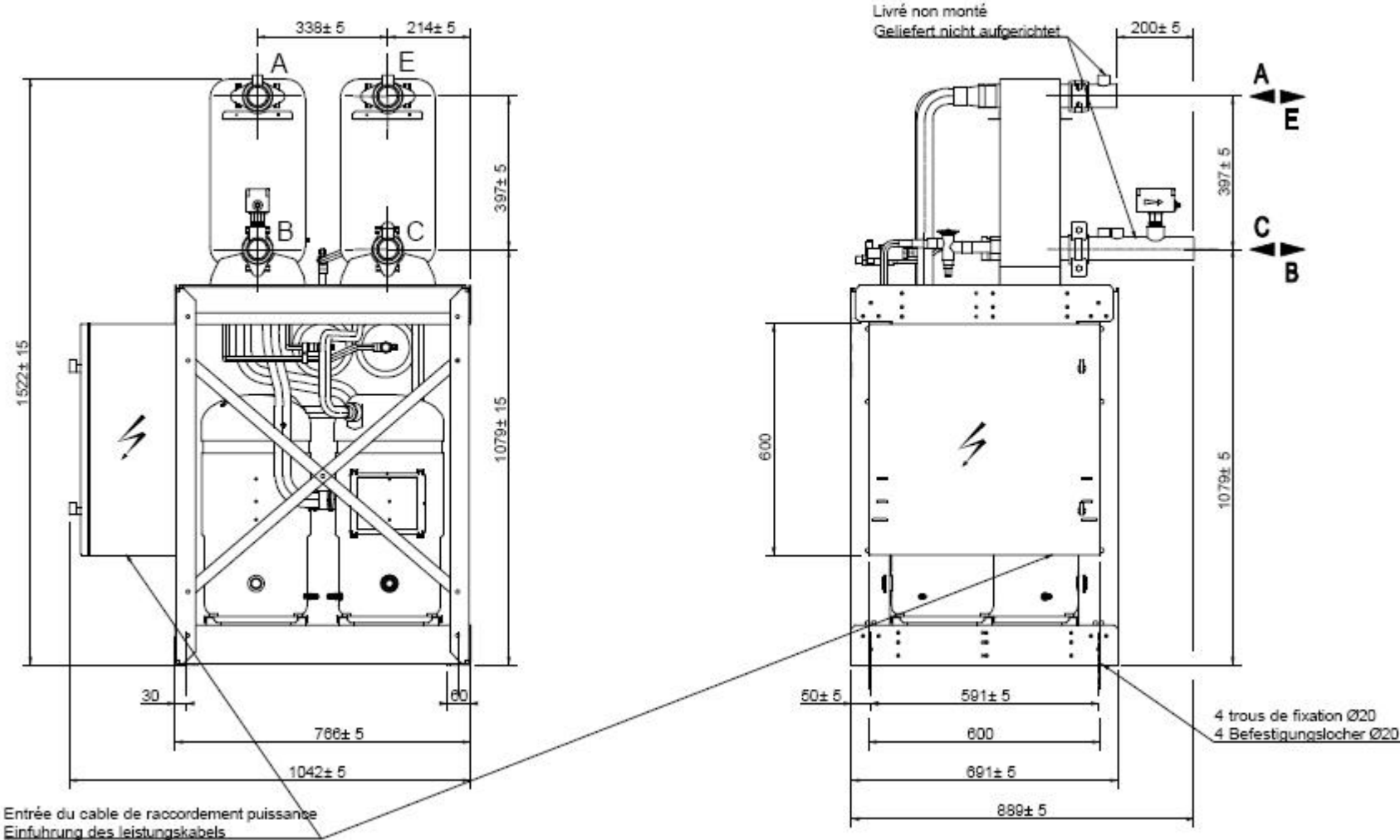

MCW 82 SK

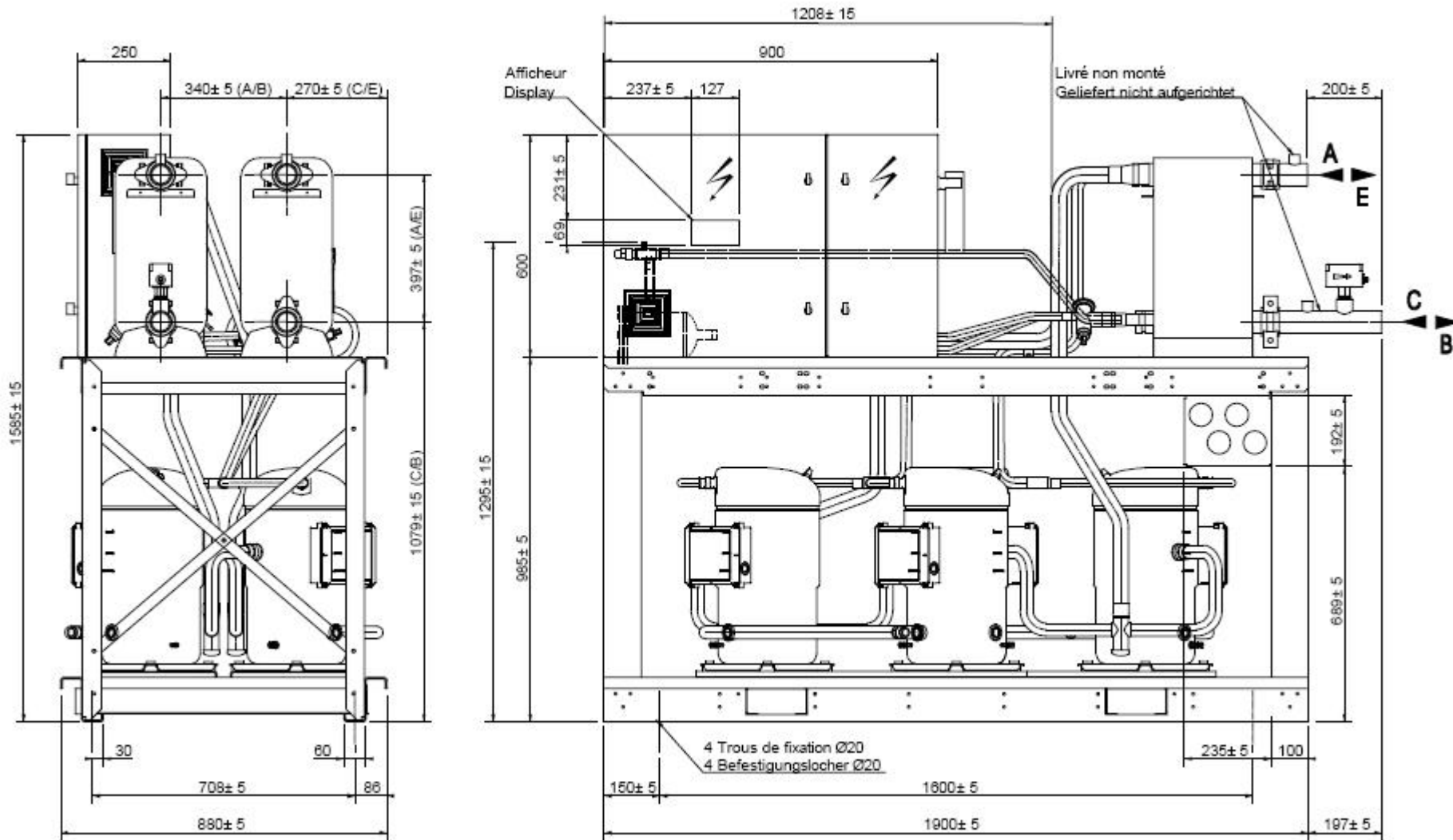

MCW 112-132-162 SK

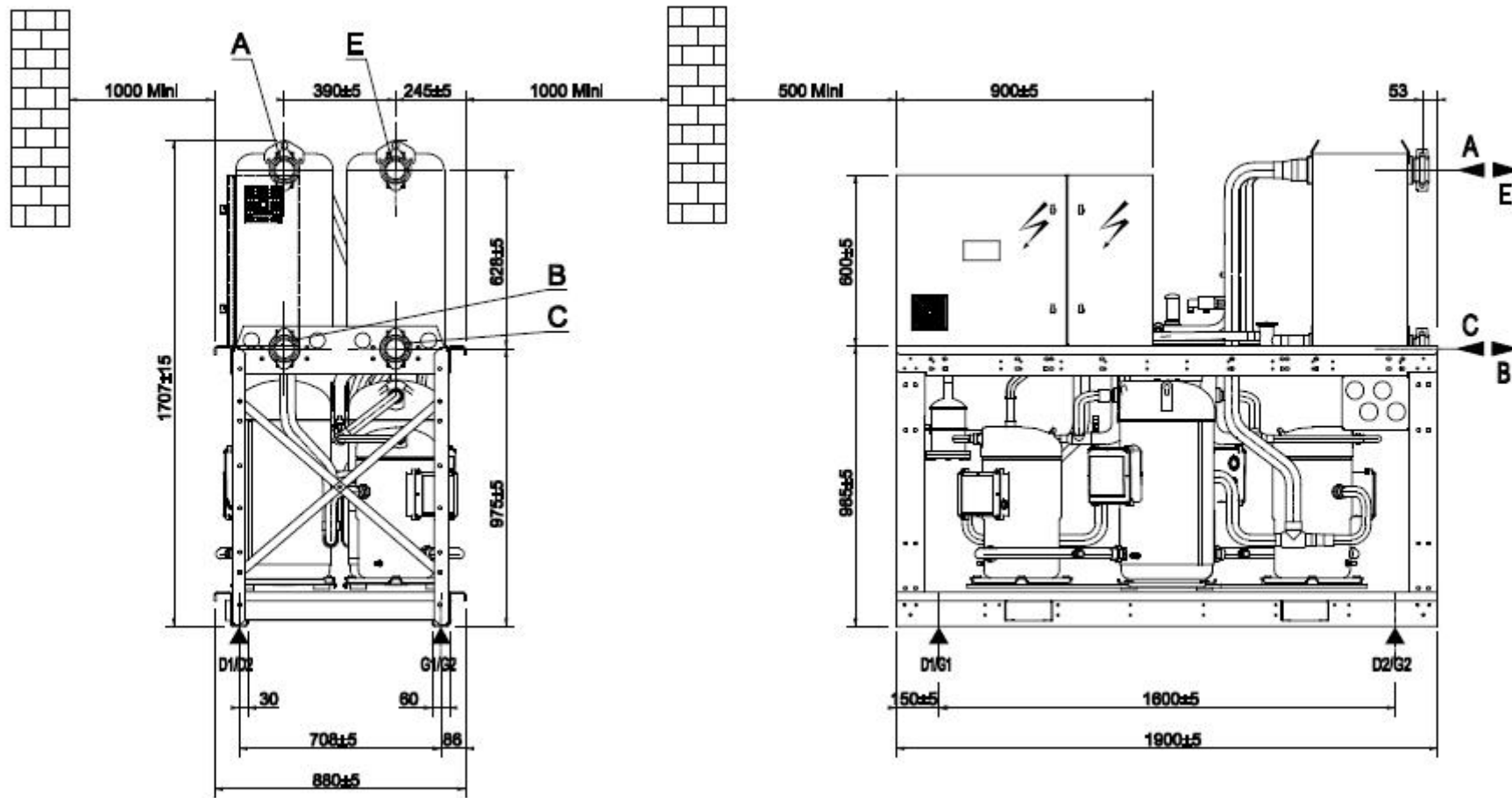

MCW 222-262-322 SK

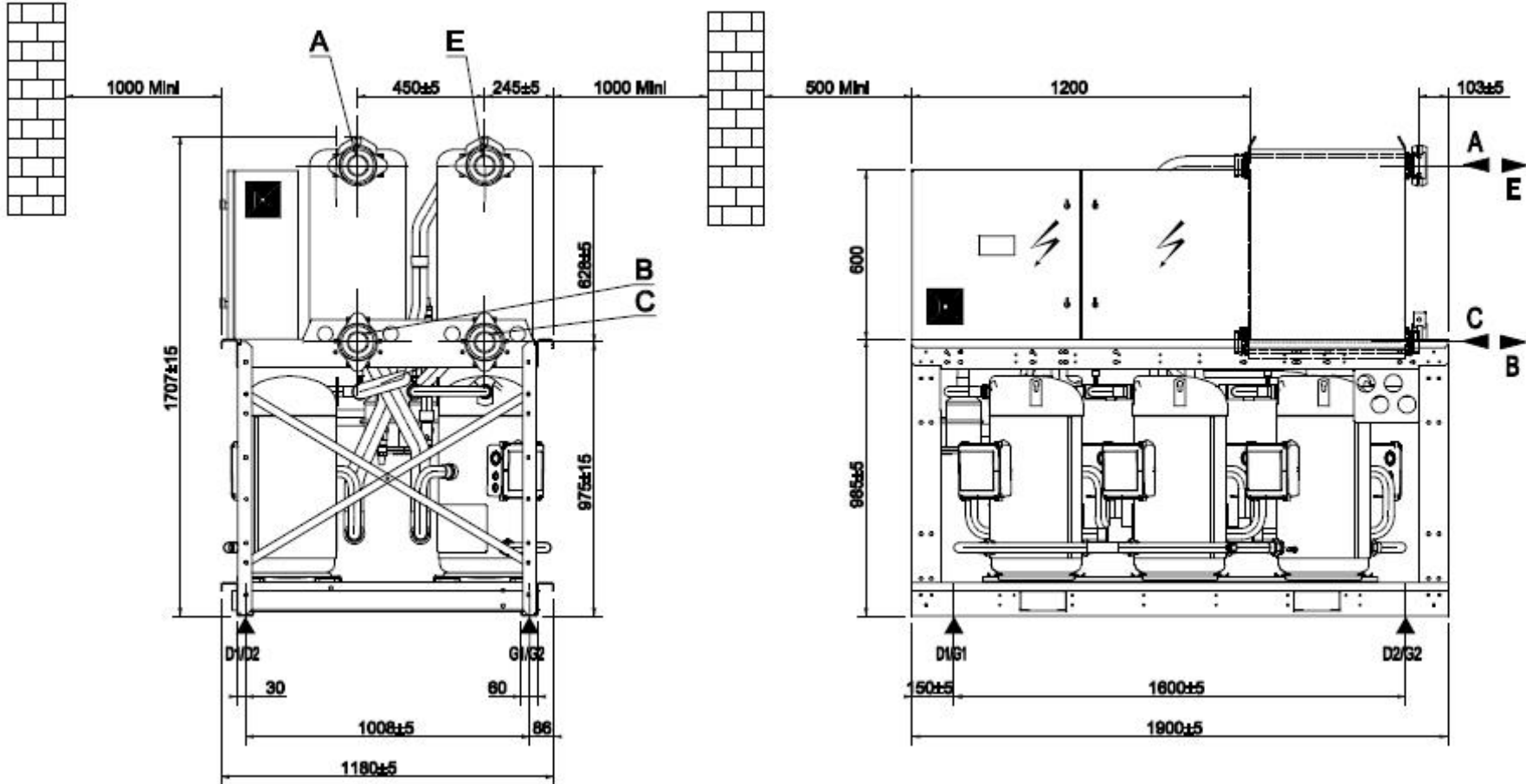

MCW 422 SK

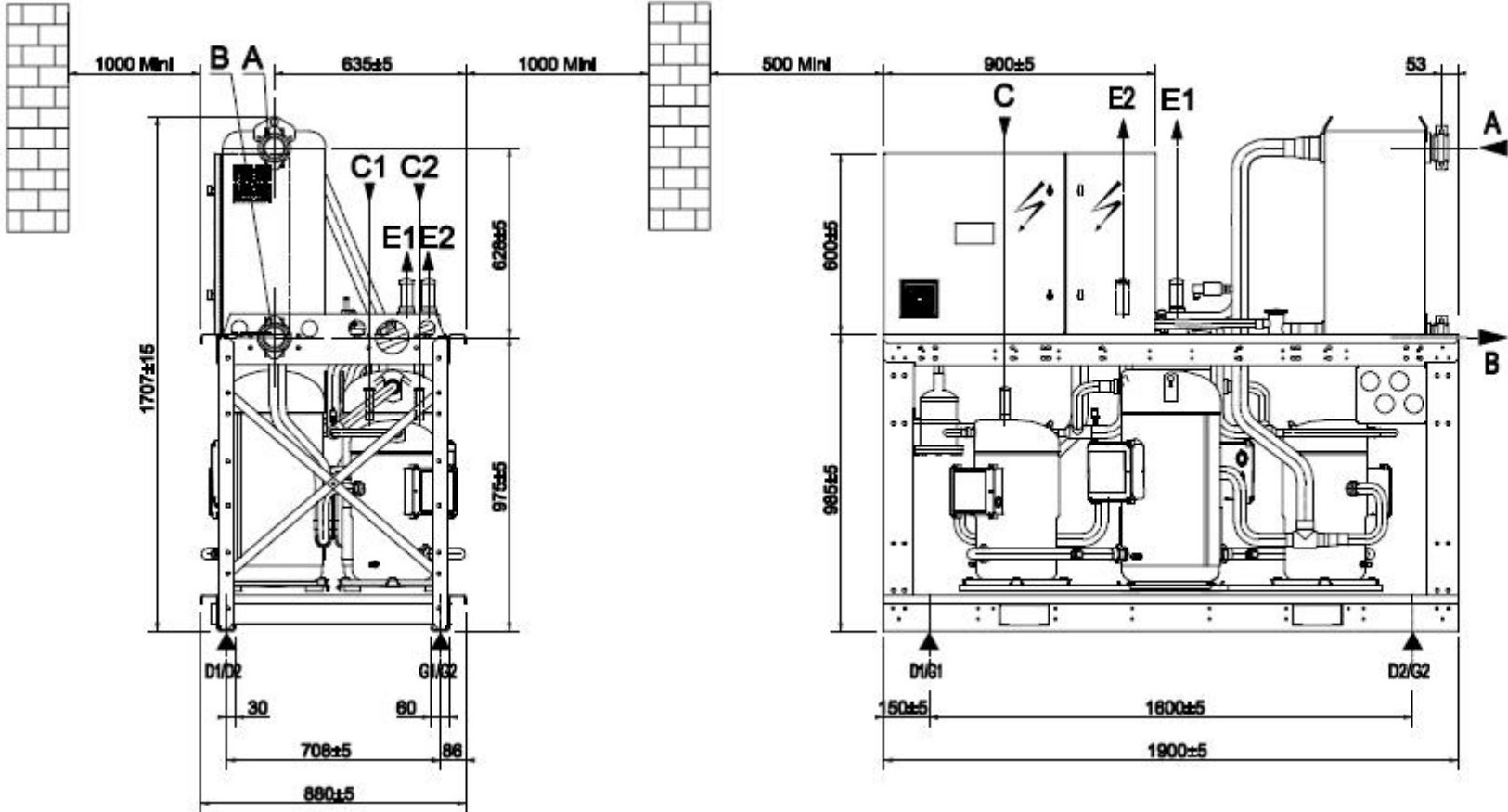

MCSB 222-262-322 SK

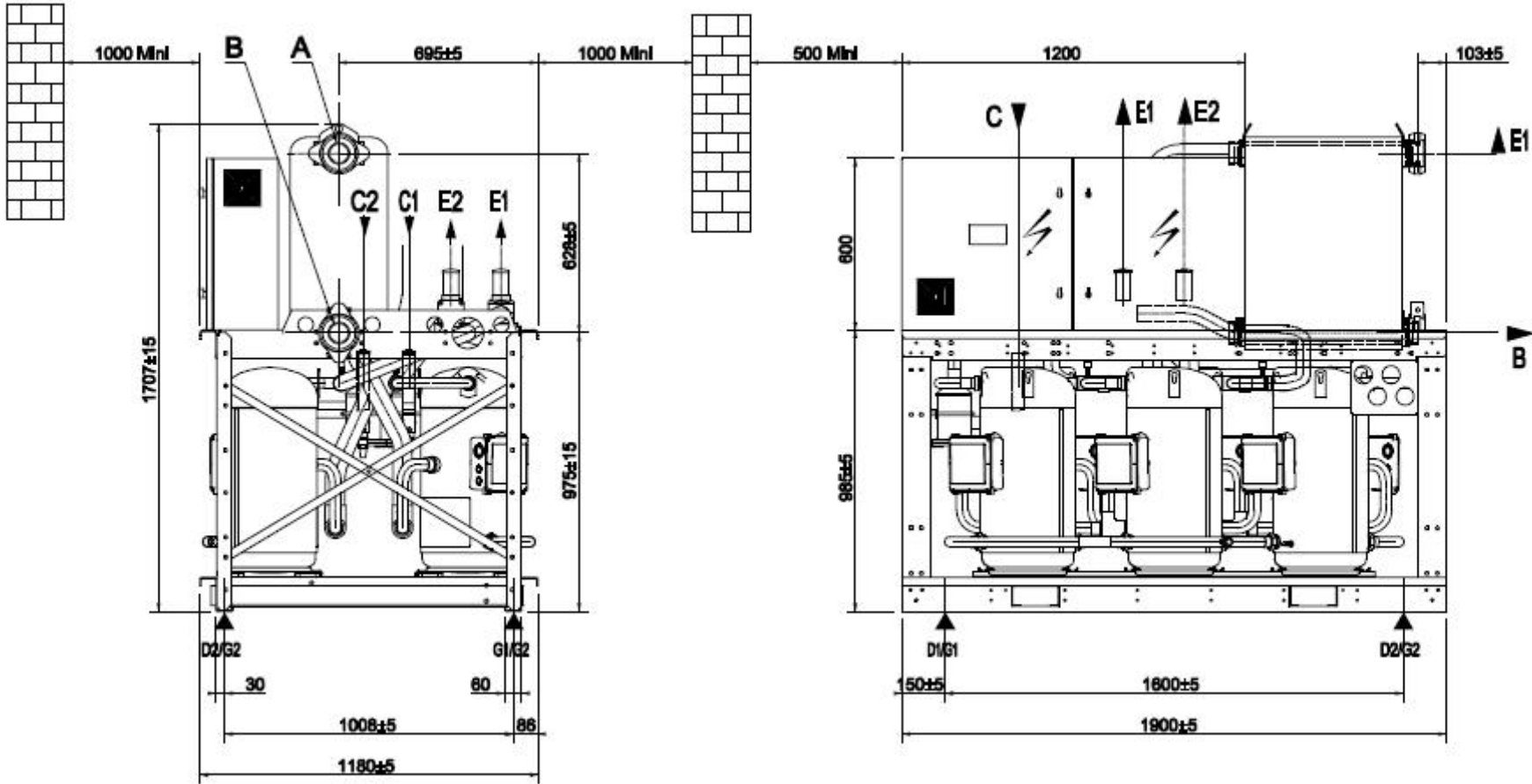

MCSB 422 SK

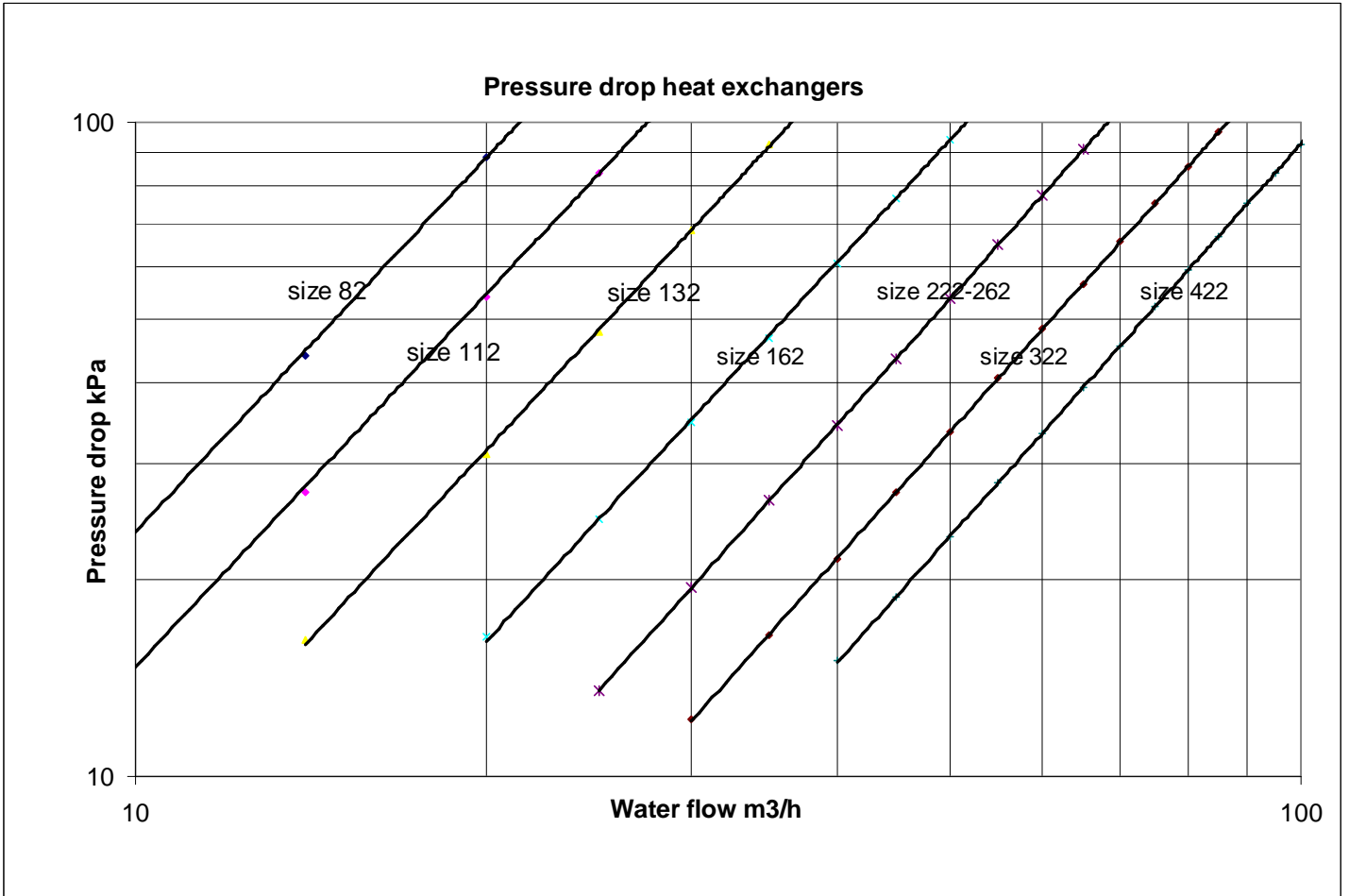



Certification

Attribuée à

LGL FRANCE

Zone Industrielle Les Meurières
69780 MIONS

FRANCE

BVQI certifie que le Système de Management de la Qualité de l'Entreprise susmentionnée a été évalué et jugé conforme aux exigences de la norme :

STANDARD

NF EN ISO 9001 : 2000

DOMAINE D'ACTIVITÉ :

CONCEPTION, FABRICATION ET CESSION INTERNE DE BIENS D'ÉQUIPEMENT DESTINÉS AU CONDITIONNEMENT D'AIR ET À LA RÉFRIGÉRATION.

DESIGN, MANUFACTURING AND INTERNAL TRANSFER OF EQUIPMENT GOODS DEDICATED TO AIR CONDITIONING AND REFRIGERATION.

Date de certification originale : **22 avril 2005**

Sous réserve du fonctionnement continu et satisfaisant du système qualité de l'entreprise, ce certificat est valable jusqu'au : **31 mars 2008**

Pour vérifier la validité du certificat, appelez le : 04.78.66.82.60

Tout éclaircissement sur cette certification peut-être obtenu auprès de l'entreprise certifiée.

Numéro de Certificat : 172696 Date : 22 avril 2005

Numéro d'Affaire : 1411599

Jean-Claude BOURGEOIS
Directeur Général



BUREAU EN CHARGE

BUREAU EMETTEUR

BVQI France S.A.
60, avenue du Général de Gaulle
92046 Paris-la-Défense Cedex
France

BVQI France – Dir. Contrats
1 rue des Vergers – Silc 4A
69760 Limonest
France



Bureau Veritas S.A. is a Notified

Body under the number 0062



ATTESTATION D'EXAMEN CE DE LA CONCEPTION (module H1)
EC DESIGN-EXAMINATION CERTIFICATE (module H1)
N° CE-PED-H1D-LEN 001-06-FRA

BUREAU VERITAS S.A., agissant dans le cadre de sa notification (numéro d'organisme notifié 0062), atteste que la conception de l'équipement sous pression identifiée ci-après, examinée selon les prescriptions du module H1 de l'annexe III de la directive "Equipements sous pression" n° 97/23/CE, est conforme aux dispositions correspondantes de la directive.

BUREAU VERITAS S.A., acting within the scope of its notification (notified body number 0062), attests that the design of an item of pressure equipment identified hereunder has been examined against the provisions of appendix III, module H1, of the Pressure Equipment directive n° 97/23/EC, and found to satisfy the provisions of the directive which apply to it.

Fabricant (Nom) / Manufacturer (Name):	LENNOX
Adresse / Address:	ZI les meurières, rue des albatros BP 71, 69780 MIONS, FRANCE
Marque commerciale / Branding name:	LENNOX
Description des équipements / Equipment description:	Ensemble sous pression, refroidisseurs de liquide à condensation par eau ou split.
Identification de la conception approuvée / Identification of the approved design:	Conception des ensembles refroidisseurs de liquide référencés dans le document DOCPED 0001 tenu à jour par le constructeur.
Versions couvertes par la conception approuvée (le cas échéant) / Versions covered by the approved design (where applicable):	Voir liste des équipements concernés.
Conditions de validité / Conditions for validity:	/

La liste des parties pertinentes de la documentation technique est annexée à la présente attestation.
A list of the relevant parts of the technical documentation is annexed to this certificate.

La présente attestation est présumée nulle et le fabricant supportera seul les conséquences de son utilisation, en cas de modification apportée à l'équipement susceptible de remettre en cause sa conformité aux exigences essentielles de sécurité ou à ses conditions d'utilisation prévues et, de manière générale, si le fabricant ne respecte pas, notamment, l'une ou l'autre des obligations mises à sa charge par la Directive 97/23/CE du 29 mai 1997 telle que transposée dans le(s) droit(s) national(aux) applicable(s).

This certificate shall be deemed to be void and the manufacturer shall alone bear any consequences pursuant to its use, in case of modification to the equipment where this may affect conformity with the essential safety requirements or the prescribed conditions for use of the equipment, and generally where the manufacturer fails in particular to comply with any of his obligations under directive nr 97/23/EC of 29 may 1997 as transposed in the applicable law(s).

Etabli à / Made at	Le (MM/JJ/AAAA) / On (MM/DD/YYYY)	Signé par / Signed by	Signature / Signature
CHARLY	10/31/2006	Jean-Marc Cabuzel	
Code d'enregistrement / Registration code: 2007/39.17.8663/P			

La présente attestation est soumise aux Conditions Générales de Service de Bureau Veritas jointes à la demande d'intervention signée par le demandeur. *This certificate is subject to the terms of Bureau Veritas General Conditions of Service attached to the agreement signed by the applicant.*

