

OPERATING LIMITS

Flow rate	up to 85 m ³ /h
Height	up to 24 m
Max pressure at the outlet	6.5 bar
Max pressure at the inlet	4 bar
Temperature range :	-20 °C to 60 °C
Ambient temperature	-15°C to +50°C

SHC

HORIZONTAL SINGLE STAGE COMPOSITE PUMP

Fix or variable speed pump

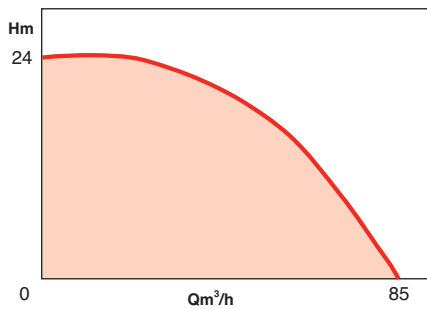

APPLICATIONS

- Chiller
- Swimming pool
- Balneo
- Washing machine / Tunnels

ADVANTAGES

- Different possible direction for the outlet
- Possibility to integrate sensor 1/4"
- Foot customizing Hydraulic fixation Victaulic or thread
- High hydraulic efficiency
- Low life cycle cost
- Full life grease ball bearing.
- Corrosion resistant
- Very low thermal lose through composite casing
- Possibility of thermal sensor

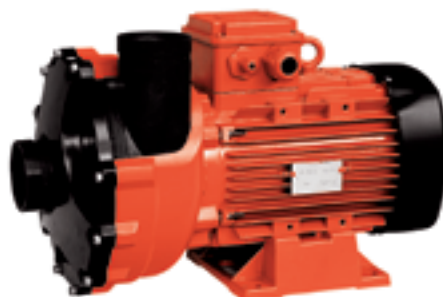

DESIGN

• Hydraulic parts

- Complete composite, monobloc
- Centrifugal single stage
- Axial Inlet / Off line outlet
- Mechanical seal rotative tightness.

• Motor

- Fan cooled motor
 - Long shaft
 - Three phased with or without thermal sensor
- Speed: 2900 RPM
 Winding: 400 V- 50 Hz
 Insulation class: 155 (F)
 Protection index: IP54

STANDARD CONSTRUCTION

Main parts	Material
Hydraulic	Composite
Ring holder	PPA
Casing	PA6.6 GF
Impeller	PPO / PA6.6
Mechanical seal	Carbon - Silicium carbide - EPDM
Shaft	Stainless steel
O Ring	EPDM

HYDRAULIC SELECTION CHARTS

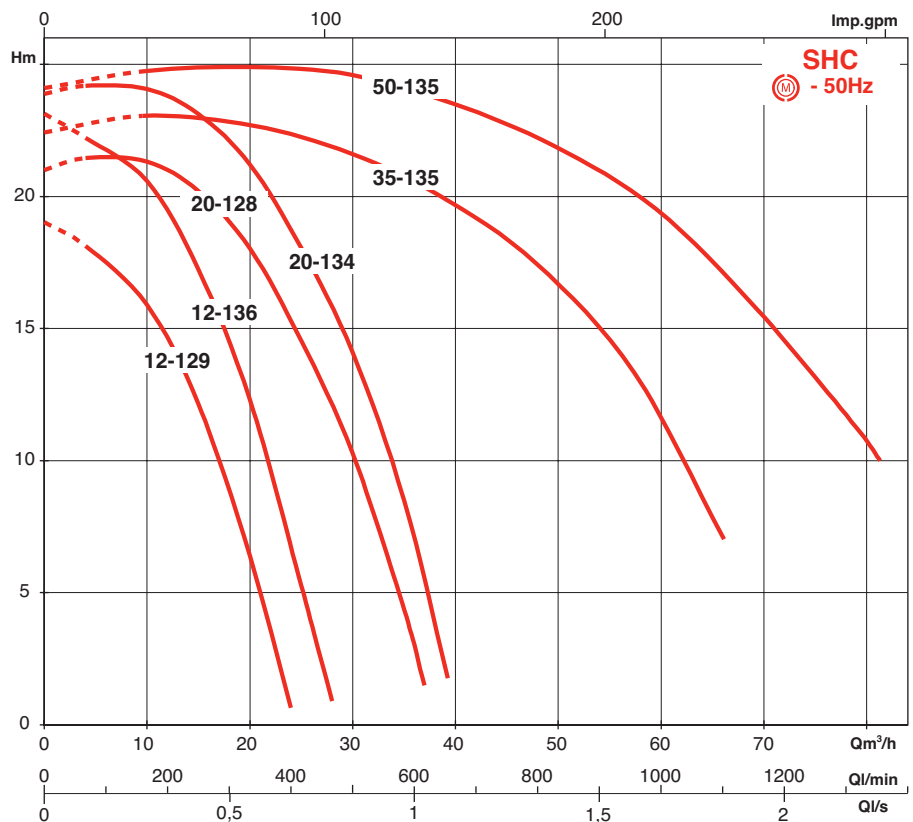

IDENTIFICATION

SHCE20-134/1.85-T-6/A-E/R-270-1/2G/OEM/XX/B

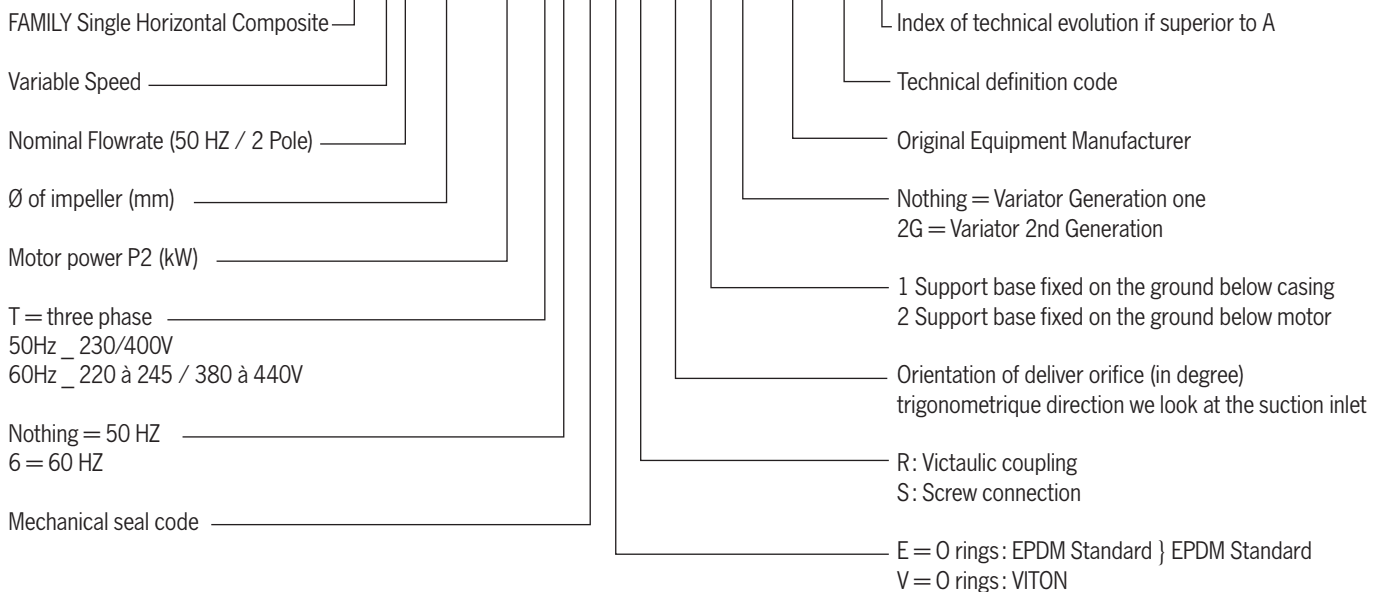

SECTIONAL VIEW

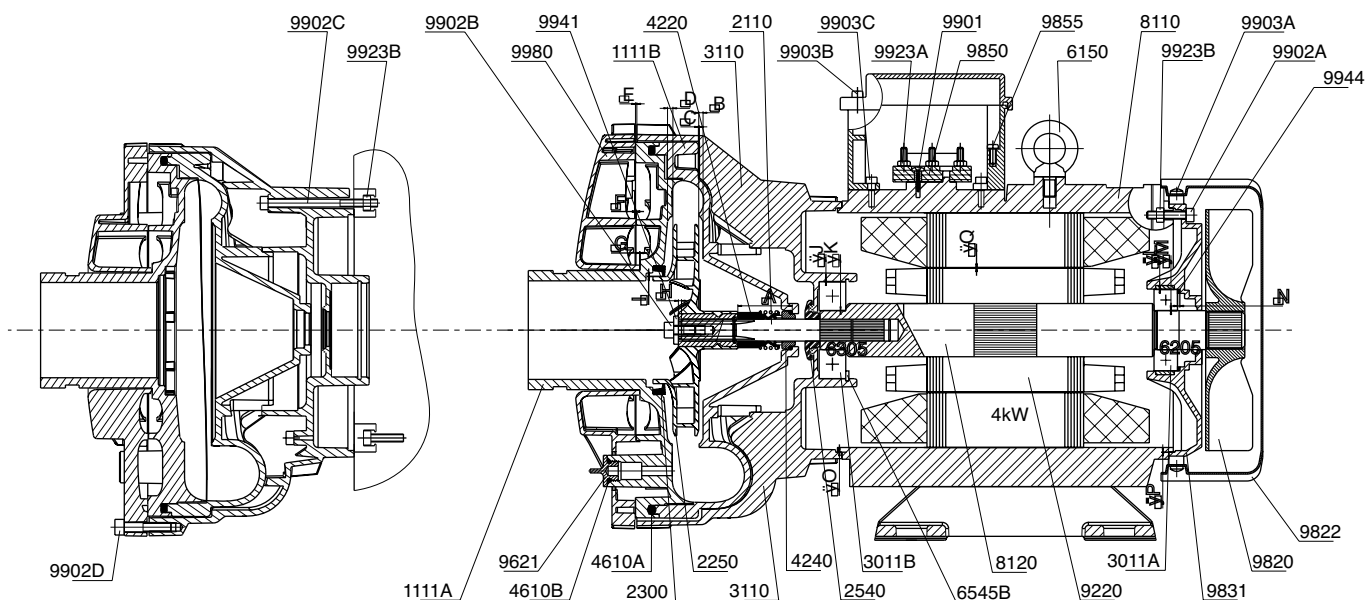

Cablage moteur triphase

Motor connections triples phase

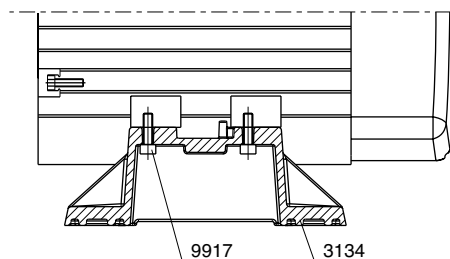
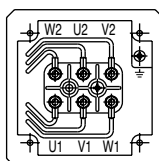

Part list

- 1111 Pump casing
- 2110 Pump shaft
- 2250 Radial flow impeller shrouded
- 2300 Impeller wear ring
- 2540 Thrower
- 3011 Radial ball bearing
- 3110 Bearing pedestal
- 3111 Bearing pedestal with flange for motor
- 3134 Support foot
- 4220 Rotating seal ring
- 4421 Shaft seal pipe
- 4610 Round section joint ring
- 6150 handling ring
- 6545 Circlip for shaft
- 8110 Motor casing
- 8120 Motor shaft
- 9220 Rotor laminations
- 9820 Fan
- 9822 Fan cover
- 9831 Rear endshield
- 9850 Terminal plate
- 9901 Slotted cheese head screw
- 9902 Hexagon socket heat cap screw
- 9903 Recessed cheese head screw
- 9917 Self-former screw
- 9923 Hexagon nut
- 9941 Plain washer
- 9944 Curved spring washer
- 9980 End shaft screw

EXPLODED VIEW

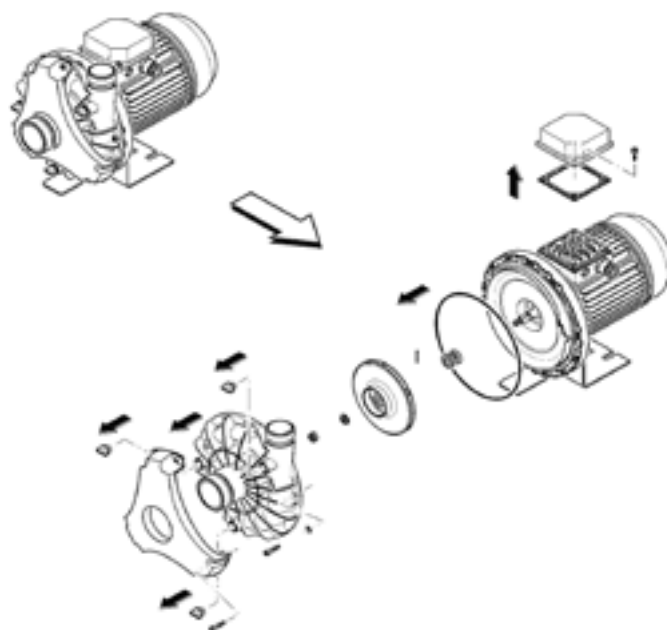

INSTALLATION

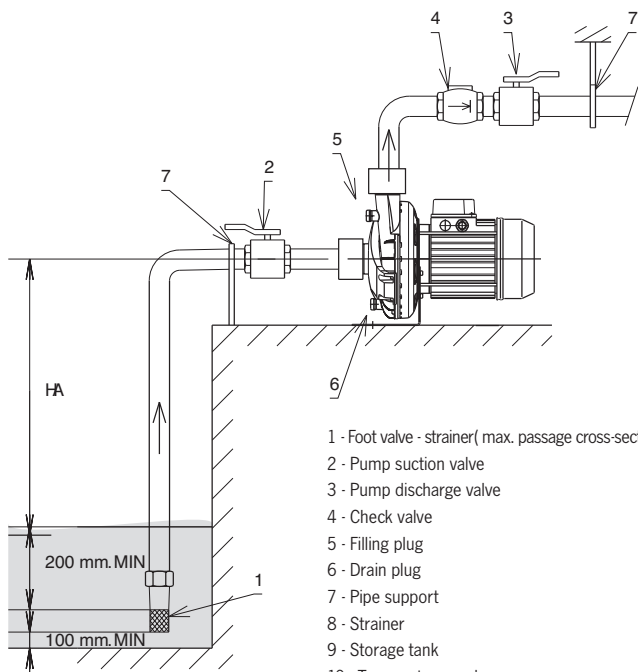

- 1 - Foot valve - strainer (max. passage cross-section of 1 mm)
- 2 - Pump suction valve
- 3 - Pump discharge valve
- 4 - Check valve
- 5 - Filling plug
- 6 - Drain plug
- 7 - Pipe support
- 8 - Strainer
- 9 - Storage tank
- 10 - Town water supply
- 11 - Motor protection relay for three-phase motor
- HA - Suction head
- HC - Discharge head

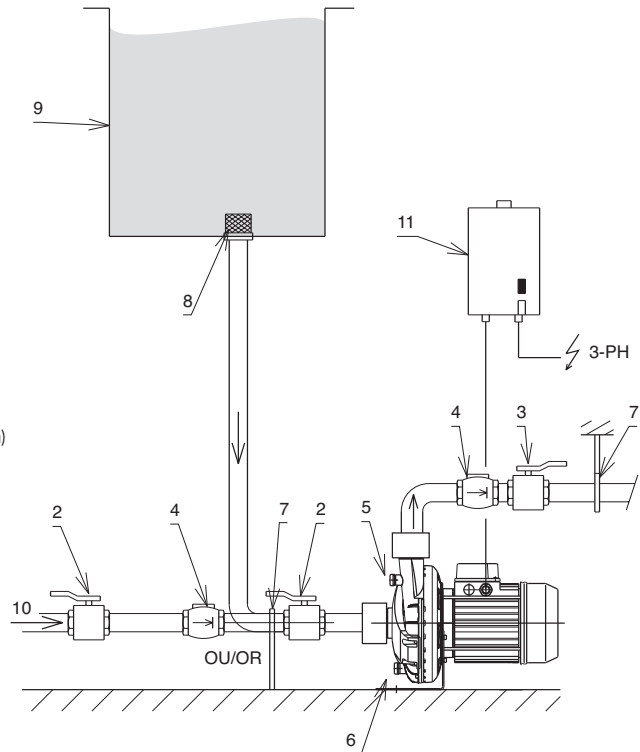

Cautious for installation and use :

- Liquid use in the cooling system circuit have to be in accordance with the VDI 2035 standard
- The maximum percentage of glycol acceptable is 35 %
- Some additives like descaler, stop-leakage; anti-corrosion could damage the parts of the pump

- Be cautious. Antifreeze additives must absolutely be neutral with the pump parts.
- No aggressive water: demineralised, de-ionised, sea water
- No oil emulsions
- Maximum viscosity = 50 cst
- Maximum density = 1.050 kg/m³

Connexion cautious

It is advice to connect the hydraulic parts before fixing the pump to the floor. The maximum strains for the casing are the following :

Max strain on the casing	Victaulic Flexible		Threat	
	Force	Torque	Force	Torque
Ø SUCTION	500 N	30 N.m	500 N	30 N.m
Ø DISCHARGE	500 N	30 N.m	500 N	30 N.m

Filling cautious

The filling of the pump must be done at a low flow rate without water hammer choc (Below 5 m³/h)

Fill out the air correctly with the upper plug especially when the discharge is horizontal.

ELECTRICAL CONNECTION

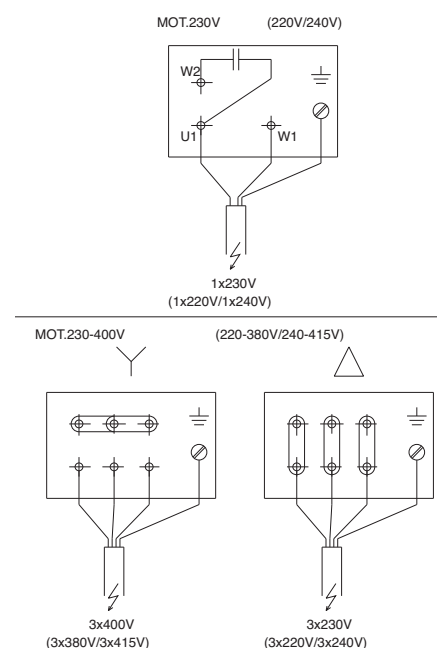

FLOW RATE RANGE

The large flow rate range is adapted to chillers from 40 kW to 300 kW.

The exceptional hydraulic efficiency reduce significantly the electrical consumption of the pump and so, follows the way of thinking of Kyoto rules and the French thermal regulation 2000 (Décret 2000-1153).

The mechanical load and electric consumption are increased by around 5 % when the liquid is made of 30 % of ethylene glycol at - 10°C

Pump	Nominal Flow rate	Ø Impeller	Number of pole	Frequency	Q Flow	H Height	P2 Power	P1 Power	Speed	Pump efficiency
		mm		Hz	m ³ /h	m	kW	kW	RPM	%
SHC 12-129	12	129	2	50	0	19,02	0,37	0,58	2890	0,00
	12	129	2	50	4	18,12	0,56	0,73	2830	35,46
	12	129	2	50	10	15,91	0,67	0,96	2775	64,42
	12	129	2	50	15	12,14	0,72	1,07	2749	69,11
	12	129	2	50	20	6,38	0,69	1,09	2761	50,39
	12	129	2	50	24	0,64	0,62	1,03	2806	6,78
SHC 12-136	12	136	2	50	0	23,14	0,53	0,77	2933	0,00
	12	136	2	50	4	22,22	0,76	1,03	2902	31,87
	12	136	2	50	10	20,59	0,93	1,24	2871	60,33
	12	136	2	50	15	17,23	1,03	1,35	2853	68,37
	12	136	2	50	20	12,28	1,04	1,39	2846	64,35
	12	136	2	50	25	5,27	0,98	1,31	2862	36,63
SHC 20-128	12	136	2	50	28	0,9	0,89	1,19	2876	7,72
	20	128	2	50	0	21	0,49	0,77	2955	0,00
	20	128	2	50	4	21,45	0,71	0,95	2938	32,93
	20	128	2	50	10	21,32	0,94	1,27	2914	61,80
	20	128	2	50	15	20,19	1,15	1,52	2893	71,76
	20	128	2	50	20	18,02	1,29	1,69	2867	76,13
	20	128	2	50	25	14,55	1,39	1,82	2844	71,31
	20	128	2	50	30	10,27	1,47	1,93	2836	57,11
SHC 20-134	20	128	2	50	35	4,34	1,47	1,93	2831	28,16
	20	128	2	50	37	1,5	1,46	1,92	2832	10,36
	20	134	2	50	0	23,88	0,64	0,92	2956	0,00
	20	134	2	50	4	24,19	0,88	1,19	2942	30,01
	20	134	2	50	10	24,07	1,12	1,47	2920	58,72
	20	134	2	50	15	23,11	1,36	1,74	2898	69,55
	20	134	2	50	20	21,2	1,55	1,96	2876	74,63
	20	134	2	50	25	18,06	1,68	2,13	2858	73,14
SHC 35-135	20	134	2	50	30	14,09	1,79	2,26	2844	64,24
	20	134	2	50	35	8,47	1,85	2,34	2833	43,78
	20	134	2	50	39,25	1,76	1,84	2,32	2835	10,21
	35	135	2	50	0	22,42	1,04	1,38	2963	0,00
	35	135	2	50	9,57	23,05	1,49	1,92	2946	40,34
	35	135	2	50	19,13	22,76	1,86	2,40	2933	63,78
	35	135	2	50	28,7	21,79	2,26	2,93	2915	75,40
	35	135	2	50	38,27	20,07	2,59	3,42	2898	80,81
SHC 50-135	35	135	2	50	47,83	17,46	2,82	3,85	2872	80,69
	35	135	2	50	57,4	13,32	2,92	4,07	2857	71,35
	35	135	2	50	66,14	7,03	2,84	3,90	2869	44,61
	50	135	2	50	0	24,1	1,30	1,62	2968	0,00
	50	135	2	50	9,92	24,75	1,84	2,19	2961	36,36
	50	135	2	50	19,84	24,9	2,30	2,72	2945	58,53
	50	135	2	50	29,77	24,61	2,77	3,27	2934	72,07
	50	135	2	50	39,69	23,53	3,18	3,82	2914	80,02
	50	135	2	50	49,61	21,91	3,55	4,34	2901	83,43
	50	135	2	50	59,54	19,51	3,83	4,77	2887	82,64
SHC 50-135	50	135	2	50	69,46	15,66	3,97	5,05	2873	74,66
	50	135	2	50	79,39	11,06	4,02	5,13	2871	59,52
	50	135	2	50	81,31	9,99	4,00	5,10	2871	55,33

HYDRAULIC PERFORMANCES - 50Hz

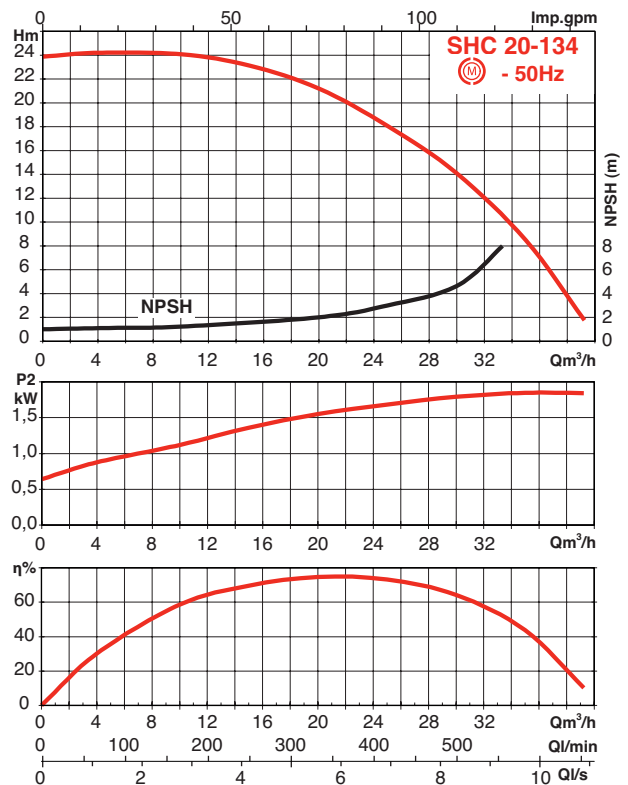
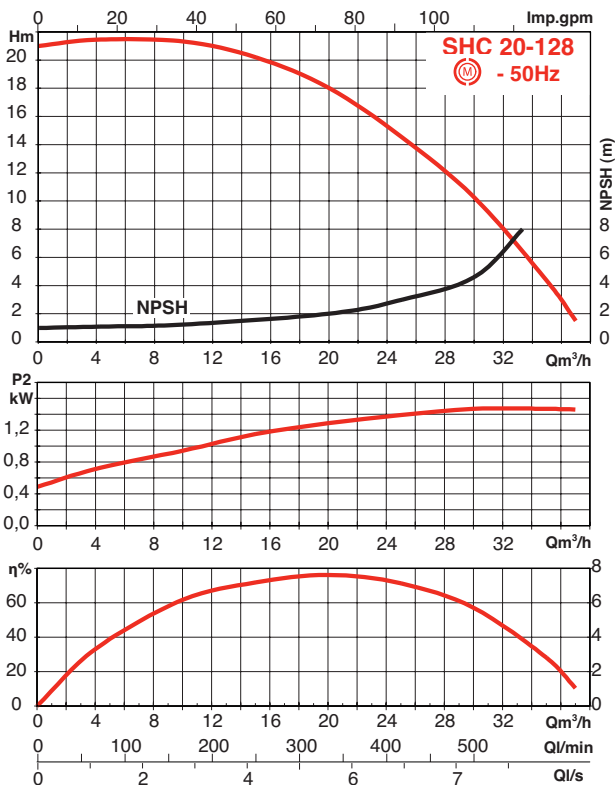
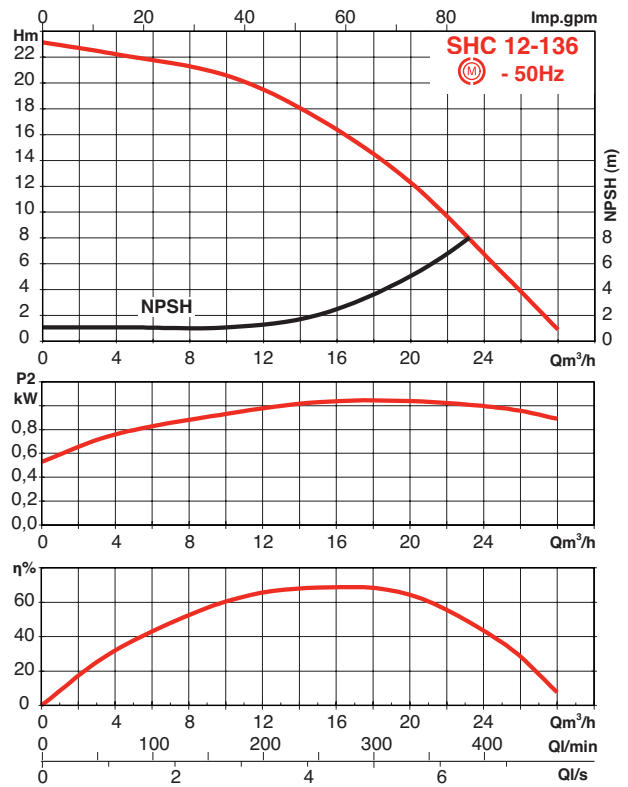
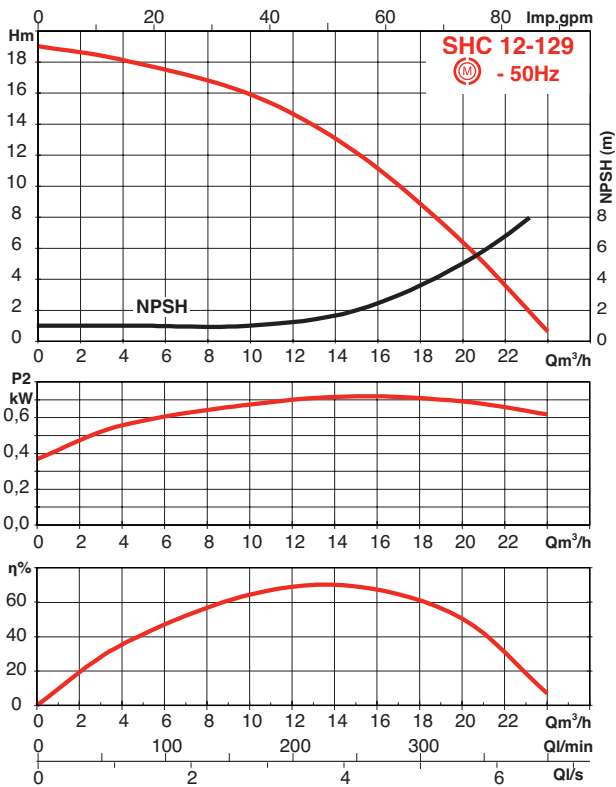

HYDRAULIC PERFORMANCES - 50Hz

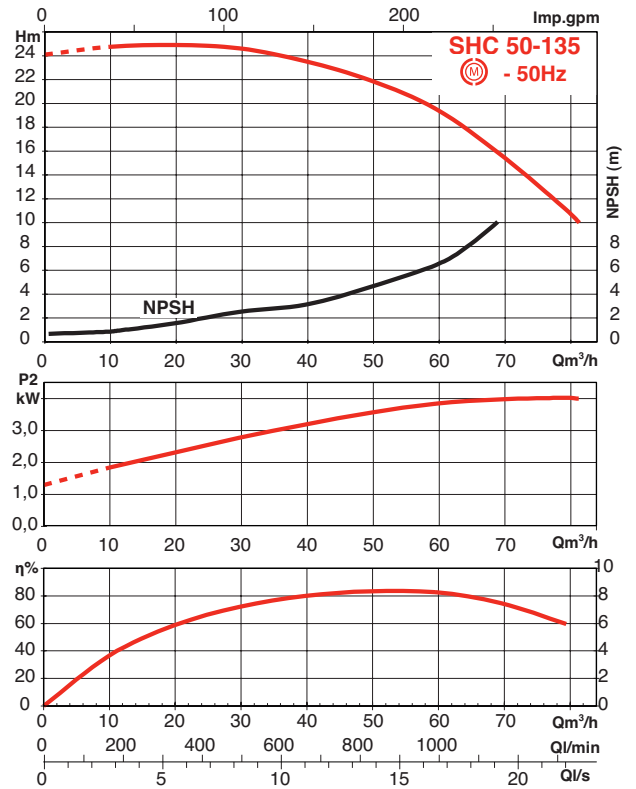
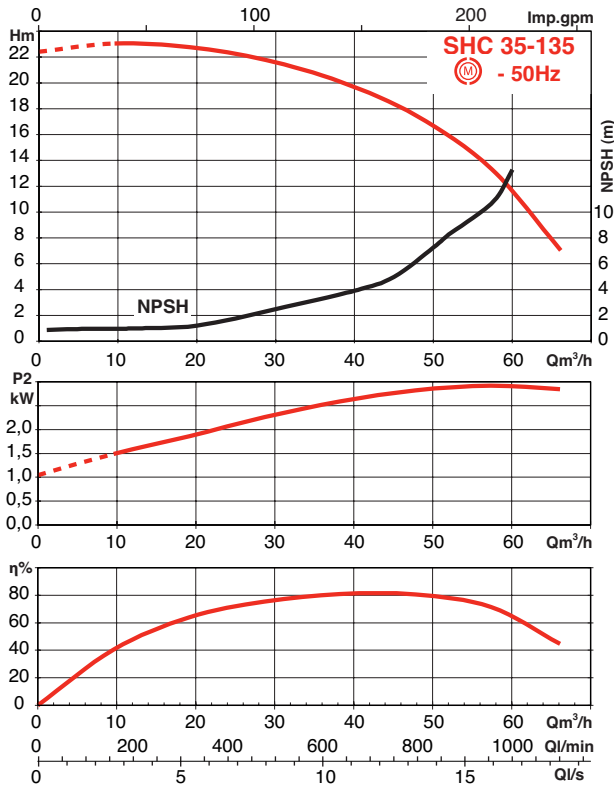

ELECTRICAL DATA AND DIMENSIONS

• SHC 2 kW

ORDER REFERENCE	TYPE	Index Tech.	~	Voltage	f	I	I	P1	P2	Ø impeller	Ø suction orifice	Ø deliver orifice	H	H1	L	E	Weight (Without Packaging)	Weight (With Packaging)
4081964	SHC12-120/1.1-T-6/A-E/R-2	3		220/380V	60	4,8	2,8	1,47	1,1	120	2"	1 ^{1/2} "	280	235	347	230	12,7	12,7
4081967	SHC12-120/1.1-T-6/A-E/S-2	3		220/380V	60	4,8	2,8	1,47	1,1	120	2"	1 ^{1/2} "	280	235	347	230	12,7	12,7
4081965	SHC12-128/1.5-T-6/A-E/R-2	3		220/380V	60	5,9	3,4	1,8	1,5	128	2"	1 ^{1/2} "	280	246	356	230	13,8	13,8
4081968	SHC12-128/1.5-T-6/A-E/S-2	3		220/380V	60	5,9	3,4	1,8	1,5	128	2"	1 ^{1/2} "	280	246	356	230	13,8	13,8
4061681	SHC12-129/0.75-T/A-E/R-2	/B	3	230/400V	50	3,6	2,1	1,08	0,75	129	2"	1 ^{1/2} "	280	235	347	230	10,4	10,4
4061685	SHC12-129/0.75-T/A-E/S-2	/B	3	230/400V	50	3,6	2,1	1,08	0,75	129	2"	1 ^{1/2} "	280	235	347	230	10,4	10,4
4061682	SHC12-136/1.1-T/A-E/R-2	/B	3	230/400V	50	5,3	3,1	1,44	1,1	136	2"	1 ^{1/2} "	280	235	347	230	12,7	12,7
4061686	SHC12-136/1.1-T/A-E/S-2	/B	3	230/400V	50	5,3	3,1	1,44	1,1	136	2"	1 ^{1/2} "	280	235	347	230	12,7	12,7
4081966	SHC12-136/1.85-T-6/A-E/R-2	3		220/380V	60	7,3	4,2	2,26	1,85	136	2"	1 ^{1/2} "	280	246	356	230	15,4	15,4
4081969	SHC12-136/1.85-T-6/A-E/S-2	3		220/380V	60	7,3	4,2	2,26	1,85	136	2"	1 ^{1/2} "	280	246	356	230	15,4	15,4
4061683	SHC20-128/1.5-T/A-E/R-2	/B	3	230/400V	50	6,6	3,8	1,92	1,5	128	2"	1 ^{1/2} "	280	246	356	230	13,8	13,8
4061687	SHC20-128/1.5-T/A-E/S-2	/B	3	230/400V	50	6,6	3,8	1,92	1,5	128	2"	1 ^{1/2} "	280	246	356	230	13,8	13,8
4061684	SHC20-134/1.85-T/A-E/R-2	/B	3	230/400V	50	8,55	4,95	2,45	1,85	134	2"	1 ^{1/2} "	280	246	356	230	15,4	15,4
4061688	SHC20-134/1.85-T/A-E/S-2	/B	3	230/400V	50	8,55	4,95	2,45	1,85	134	2"	1 ^{1/2} "	280	246	356	230	15,4	15,4

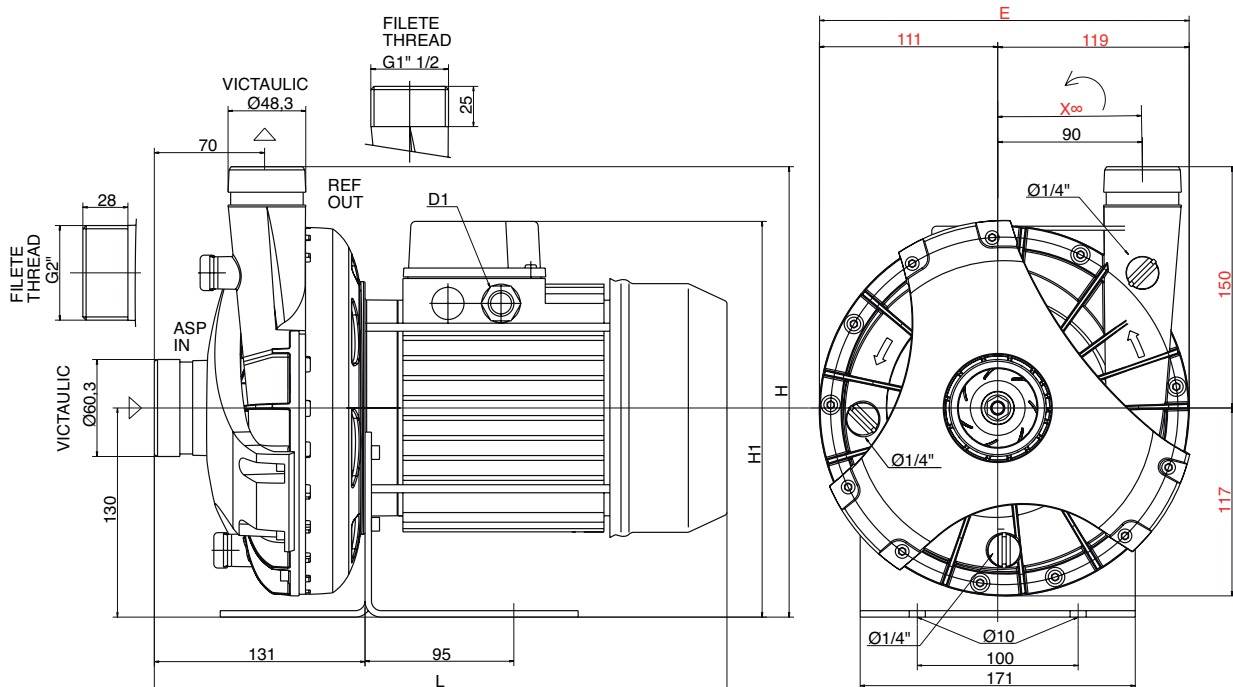

ELECTRICAL DATA AND DIMENSIONS

•SHC 4 kW

ORDER REFERENCE	TYPE	Indices Tech.	~	Voltage	f	I	I	P1	P2	Ø impeller	Ø suction orifice	Ø deliver orifice	H	H1	L	E	Weight (Without Packaging)	Weight (With Packaging)
4095271	SHC35-135/3-T/A-E/R-2	3	230/400V	50	10,7	6,2	3,8	3	135	3"OD	3"OD	291	300	463	263	24,5	26,8	
4095272	SHC50-135/4-T/A-E/R-2	3	230/400V	50	12,8	7,4	4,9	4	135	3"OD	3"OD	291	300	463	263	26,5	28,8	

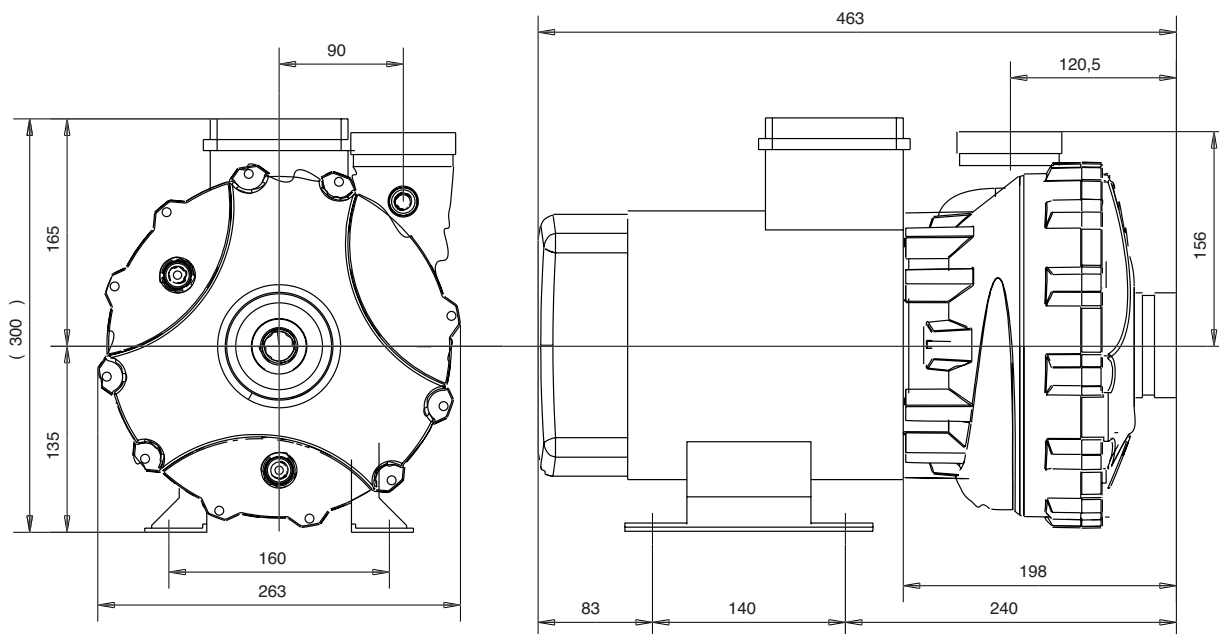

LIFE CYCLE COST :

The Life Cycle Cost must be calculated for each use according to the application of the cooling.

As an example, we will consider a building equipped by a reversible chiller of around 200 kW working more or less 8 months per year. When we look at the pump consumption, we will base our calculation at a working point of 22 m³/h—19 m of head.

At this point,

Hydraulic = 74%, and $P_{\text{electric}} = 2,1 \text{ kW}$ for a mix of water and 30% of ethylene glycol.

The figure to take in account are :

Acquisition cost + Installation cost

(Victaulic connection, Hirschmann connection : max : 15 min (OEM case)

Working cost - In the previous condition :

5 800 h = 12200 kW/h / year

(139 MWh TTC – average cost in UE)

+

Maintenance cost wearing parts

= Mechanical seal + Ball bearing (see life time table)

Life target

(MTBF of other parts than wear part > 80 000 h) : 40 000 h

Recycling cost + No bi-material parts except the motor parts (winding and rotor) :

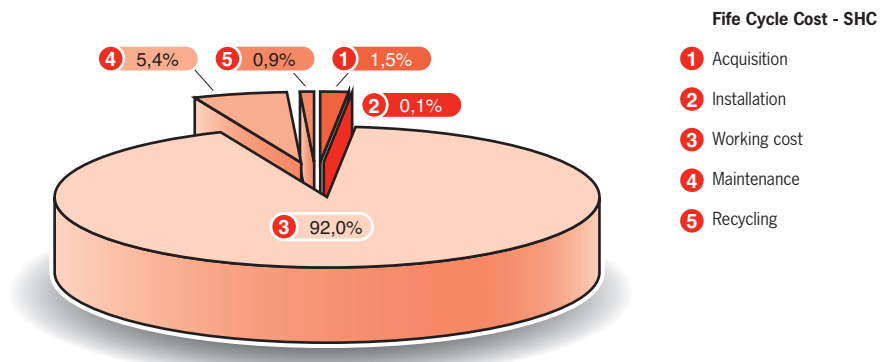

A delta of 5 points of hydraulic efficiency lead to a modification of 4,5 % of the end user life cycle cost



FEATURES

a) Electrical

- Standard connection in the terminal box
- Connexion with Hirschmann connector (in option)
- Thermal sensor in option : PTO.

b) Installation

- Easy and flexible fixation on the floor
- Easy to lift (lifting ring)
- Can be customized.
- 2 pumps connections are available : Victaulic or Threat
- The outlet can be turned in any direction perpendicularly to the impeller shaft.

c) Packaging

- individual packaging
- return collective packaging per 6 pumps (ISO14000)
- cardboard collective packaging per 18 pumps

d) Maintenance

- Replacement of wearing parts according to life time

Life time in normal conditions

	SHC12-20	SHC35-50
Mechanical seal	10 000 h	10 000 h
Ball bearing	20 000 h	40 000 h
Motor winding	40 000 h	40 000 h
Hydraulic	40 000 h	40 000 h

SHCE

The variable speed on the SHCE provide to the chillers the possibility to work at the optimised point of the chillers. The compressor can in that case be optimised. For a dedicated temperature, the SHCE provide the exact exchange you need and have an electrical consumption in accordance with this point.

The maximum hydraulic performances of the SHCE20-134 are the same as the SHC20-134.

This pump can be driven by a 4-20 mA signal or a communication bus (LON).