

**LENNOX<sup>®</sup>**

INSTALLATION  
OPERATING &  
MAINTENANCE MANUAL



PROVIDING GLOBAL SYSTEM SOLUTIONS

ECOLEAN  
EAC/EAR

English  
July 2003



## TABLE OF CONTENTS

### DATA PAGE FOR UNIT COMMISSIONING

PAGE 2

### 1.- GENERAL CHARACTERISTICS

PAGE

1.1.- TECHNICAL DATA	3-4
1.2.- ELECTRICAL DATA	5-7
1.3.- COMPONENT	8
1.4.- OPERATION LIMITS	9-10
1.5.- PRESSURE DROP IN THE WATER SYSTEM	11
1.6.- HYDRAULIC SYSTEM DATA	12
1.7.- SAFETY DEVICES	13-14
1.8.- PIPING DRAWINGS	15-16
1.9.- DIMENSIONS	17-19
1.10.- OPTIONALS	20-21

### 2.- INSTALLATION

PAGE

2.1.- PRELIMINARY PREPARATIONS	22
2.2.- UNIT RECEPTION	22
2.3.- INSTALLATION CLEARANCES	23
2.4.- UNIT INSTALLATION	24-25
2.5.- ELECTRICAL CONNECTIONS	26

### 3.- COMMISSIONING AND OPERATION

PAGE

3.1.- STEPS TO FOLLOW FOR COMMISSIONING THE UNITS	27
3.2.- CHECKING THE WATER FLOW RATE	28
3.3.- CORROSION RESISTANCE OF COPPER AND STAINLESS STEEL OF PLATES EXCHANGER	29

### 4.- MAINTENANCE

PAGE

4.1.- PREVENTIVE MAINTENANCE	30
4.2.- CORRECTIVE MAINTENANCE	31
4.3.- FAILURE DIAGNOSIS	32

Our company is a member of the Eurovent Certification Programme. The Ecolean™ range of Lennox chillers are tested and rated in accordance with the Eurovent certification program.



Our company's products comply with European standards.



The manufacturing of Ecolean™ answers to ISO9001 control quality system.



Lennox have been providing environmental solutions since 1895, our range of air cooled chillers continues to meet the standards that have made LENNOX a household name. Flexible design solutions to meet YOUR needs and uncompromising attention to detail. Engineered to last, simple to maintain and Quality that comes as standard.

The specifications and technical characteristics in this booklet are given for information purposes. The manufacturer reserves the right to modify them without prior notice or obligation to modify in a similar manner, the equipments previously supplied.

**DATA PAGE FOR UNIT COMMISSIONING**

UNIT: \_\_\_\_\_ SERIAL No.: \_\_\_\_\_

CONTROL PANEL IDENTIFICATION CODE \_\_\_\_\_

INSTALLATION ADDRESS: \_\_\_\_\_

INSTALLER: \_\_\_\_\_ INSTALLER TEL.: \_\_\_\_\_

INSTALLER ADDRESS: \_\_\_\_\_

DATE OF COMMISSIONING: \_\_\_\_\_

**CHECKS:**

SUPPLY VOLTAGE: \_\_\_\_\_ RATED VOLTAGE OF THE UNIT: \_\_\_\_\_

	YES	NO
UNIT ON RUBBER ANTIVIBRATION MOUNTS	<input type="checkbox"/>	<input type="checkbox"/>
GENERAL POWER SUPPLY CONNECTION	<input type="checkbox"/>	<input type="checkbox"/>
CONTROL PANEL CONNECTION (OPTIONAL)	<input type="checkbox"/>	<input type="checkbox"/>
COMPRESSOR OIL LEVEL INDICATOR	<input type="checkbox"/>	<input type="checkbox"/>
HYDRAULIC CONNECTION	<input type="checkbox"/>	<input type="checkbox"/>
PURGED OF THE INSTALLATION	<input type="checkbox"/>	<input type="checkbox"/>

**DATA INPUT:**

**COOLING CYCLE**

Air Input Temperature, Coil: \_\_\_\_\_ °C  
 Water Output Temperature: \_\_\_\_\_ °C  
 Water Input Temperature: \_\_\_\_\_ °C  
 High Pressure: \_\_\_\_\_  
 Low Pressure: \_\_\_\_\_

**ELECTRIC POWER CONSUMPTION (Amp.)**

Compressor 1 \_\_\_\_\_ / \_\_\_\_\_ / \_\_\_\_\_  
 Fan 1 \_\_\_\_\_ / \_\_\_\_\_ / \_\_\_\_\_  
 Compressor 2 \_\_\_\_\_ / \_\_\_\_\_ / \_\_\_\_\_  
 Fan 2 \_\_\_\_\_ / \_\_\_\_\_ / \_\_\_\_\_

**HEATING CYCLE**

Air Input Temperature, Coil: \_\_\_\_\_ °C  
 Water Output Temperature: \_\_\_\_\_ °C  
 Water Input Temperature: \_\_\_\_\_ °C  
 High Pressure: \_\_\_\_\_  
 Low Pressure: \_\_\_\_\_

Compressor 1 \_\_\_\_\_ / \_\_\_\_\_ / \_\_\_\_\_  
 Fan 1 \_\_\_\_\_ / \_\_\_\_\_ / \_\_\_\_\_  
 Compressor 2 \_\_\_\_\_ / \_\_\_\_\_ / \_\_\_\_\_  
 Fan 2 \_\_\_\_\_ / \_\_\_\_\_ / \_\_\_\_\_

Options Installed: \_\_\_\_\_

Comments: \_\_\_\_\_

## 1.- GENERAL CHARACTERISTICS

### 1.1.- TECHNICAL DATA

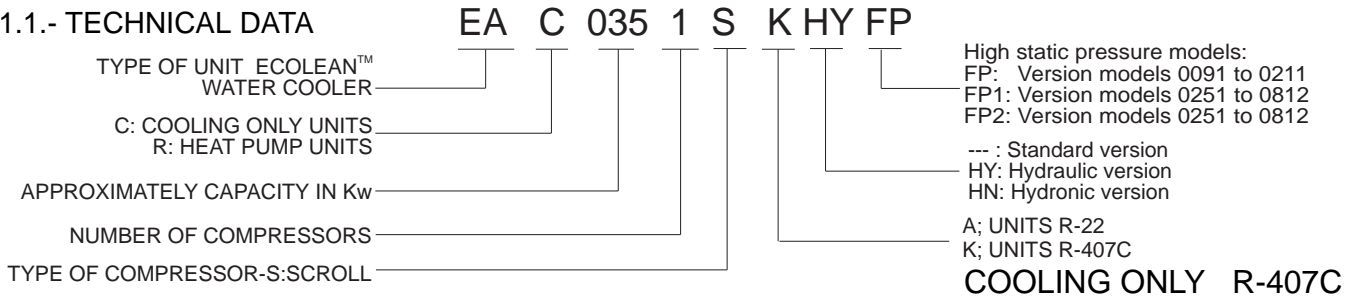

### COOLING ONLY R-407C

EAC MODELS		0091SK	0111SK	0151SK	0191SK	0211SK	0251SK	0291SK	0351SK	0431SK	0472SK	0552SK	0672SK	0812SK	
<b>Cooling capacity (*)</b>	kW.	8,5	10,5	12,5	17,0	18,5	22,5	26,0	32,0	38,5	44,0	51,0	62,5	75,0	
<b>Compressor</b>	No./Type:	1 / Scroll						2 / Scroll							
<b>Hydraulic connections</b>		1"G	1"G	1"G	1"G	1"G	1 1/2"G	1 1/2"G	1 1/2"G	1 1/2"G	2"G	2"G	2"G	2"G	
<b>Min. water rate</b>	l/h.	19,8	24,6	29,4	40,2	43,8	53,4	61,2	75,6	91,2	103,8	120,6	147,6	177,0	
<b>Net weight</b>	<b>Standard</b>	kg.	147	155	168	181	245	272	281	309	345	540	551	596	670
	<b>FP-FP1</b>	kg.	156	173	186	199	263	297	296	324	360	590	581	626	700
	<b>FP2</b>	kg.	---	---	---	---	---	317	316	344	380	630	621	666	740
<b>Refrigerant R-407C</b>	kg.	3,0	3,0	3,4	4,0	5,5	6,0	6,5	8,2	9,5	12,0	14,0	17,6	20,5	

### HEAT PUMP R-407C

EAR MODELS		0091SK	0111SK	0151SK	0191SK	0211SK	0251SK	0291SK	0351SK	0431SK	0472SK	0552SK	0672SK	0812SK	
<b>Cooling capacity (*)</b>	kW.	8,5	10,5	12,5	17,0	18,5	22,5	26,0	32,0	38,5	44,0	51,0	62,5	75,0	
<b>Heating capacity (**)</b>	kW.	8,7	10,7	13,0	17,6	19,9	23,8	26,7	33,4	41,3	46,6	52,3	65,4	81,0	
<b>Compressor</b>	No./Type:	1 / Scroll						2 / Scroll							
<b>Hydraulic connections</b>		1"G	1"G	1"G	1"G	1"G	1 1/2"G	1 1/2"G	1 1/2"G	1 1/2"G	2"G	2"G	2"G	2"G	
<b>Min. water rate</b>	l/h.	19,8	24,6	29,4	40,2	43,8	53,4	61,2	75,6	91,2	103,8	120,6	147,6	177,0	
<b>Net weight</b>	<b>Standard</b>	kg.	150	158	172	185	250	277	285	317	353	549	561	612	685
	<b>FP-FP1</b>	kg.	159	176	190	204	268	302	301	332	368	599	592	642	716
	<b>FP2</b>	kg.	---	---	---	---	---	322	321	352	388	639	632	682	756
<b>Refrigerant R-407C</b>	kg.	3,1	3,1	3,9	5,0	6,5	6,2	7,0	9,0	10,5	2 x 6,2	2 x 7,0	2 x 9,0	2 x 10,5	

### HEAT PUMP R-22

EAR MODELS		0091SA	0111SA	0151SA	0191SA	0211SA	0251SA	0291SA	0351SA	0431SA	0472SA	0552SA	0672SA	0812SA	
<b>Cooling capacity (*)</b>	kW.	8,5	10,5	12,5	17,0	18,5	22,5	26,0	32,0	38,5	44,0	51,0	62,5	75,0	
<b>Heating capacity (**)</b>	kW.	9,0	11,0	13,4	18,1	20,5	24,5	27,5	34,5	42,5	48,0	54,0	67,5	83,5	
<b>Compressor</b>	No./Type:	1 / Scroll						2 / Scroll							
<b>Hydraulic connections</b>		1"G	1"G	1"G	1"G	1"G	1 1/2"G	1 1/2"G	1 1/2"G	1 1/2"G	2"G	2"G	2"G	2"G	
<b>Min. water rate</b>	l/h.	19,8	24,6	29,4	40,2	43,8	53,4	61,2	75,6	91,2	103,8	120,6	147,6	177,0	
<b>Net weight</b>	<b>Standard</b>	kg.	150	158	172	185	250	277	285	317	353	549	561	612	685
	<b>FP-FP1</b>	kg.	159	176	190	204	268	302	301	332	368	599	592	642	716
	<b>FP2</b>	kg.	---	---	---	---	---	322	321	352	388	639	632	682	756
<b>Refrigerant R-22</b>	kg.	3,3	3,3	4,3	5,3	6,3	7,1	7,8	9,5	12,8	2 x 7,1	2 x 7,8	2 x 9,5	2 x 12,0	

\* Cooling capacity: Outside temperature: 35°C / Inlet/outlet water temperature: 12/7°C

\*\* Heating capacity: Outside temperature: 7°CDB / 6°C WB / Inlet/outlet water temperature: 45/50°C

### HYDRAULIC VERSION / HYDRONIC VERSION

<b>Pump type:</b>		Multicellular centrifugal pump with one speed												
<b>Expansion vessel</b>	Capacity	5L	5L	5L	5L	5L	12L	12L	12L	12L	18L	18L	18L	18L
<b>SET PRESSURE</b>														
	Security valves	bar	3	3	3	3	3	3	3	3	3	3	3	3
	Expansion vessel	bar	4	4	4	4	4	4	4	4	4	4	4	4
<b>Buffer tank (***)</b>	Capacity	50 L	50 L	50 L	50 L	50 L	75 L	75 L	75 L	75 L	100 L	100 L	100 L	100 L

\*\*\* Only in units with hydronic module

# 1.- GENERAL CHARACTERISTICS

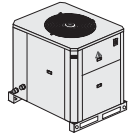

## 1.1.- TECHNICAL DATA

### STANDARD AXIAL FAN UNITS

MODELS	0091S	0111S	0151S	0191S	0211S	0251S	0291S	0351S	0431S	0472S	0552S	0672S	0812S
Fan type	Axial - Direct coupling 900 rpm 1N~230V												
Fan number	1	2				1				2			
Air flow rate m <sup>3</sup> /h	3500	6500	6700	6500	6300	9500	11500	11000	10500	19000	23000	22000	21000
Power Input kW	0,15	0,30	0,32	0,30	0,28	0,75	0,90	0,85	0,83	1,50	1,80	1,70	1,66

### HIGH STATIC PRESSURE UNITS

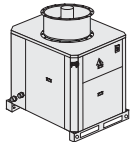

#### AVAILABLE STATIC PRESSURE UP TO 200 Pa - FP VERSION

MODELS	0091S-FP		0111S-FP		0151S-FP		0191S-FP		0211S-FP	
Fan type	Centrifugal - Direct coupling 1450 rpm 1N~230V									
Fan number	1		2							
Available static pressure Pa	Air flow rate m <sup>3</sup> /h	Power input kW	Air flow rate m <sup>3</sup> /h	Power input kW	Air flow rate m <sup>3</sup> /h	Power input kW	Air flow rate m <sup>3</sup> /h	Power input kW	Air flow rate m <sup>3</sup> /h	Power input kW
50	3500	0,9	6500	1,9	6700	1,95	6500	1,9	6300	1,85
100	2700	0,8	5700	1,75	5900	1,8	5700	1,75	5500	1,7
150	2500	0,75	5200	1,6	5400	1,65	5200	1,6	5000	1,55
200	2200	0,7	4700	1,45	4900	1,5	4700	1,45	4500	1,4

#### AVAILABLE STATIC PRESSURE UP TO 120 Pa - FP1 VERSION

MODELS	0251S-FP1		0291S-FP1		0351S-FP1		0431S-FP1		0472S-FP1		0552S-FP1		0672S-FP1		0812S-FP1	
Fan type	Axial - Direct coupling 1450 rpm 1N~230V															
Fan number	1								2							
Available static pressure Pa	Air flow rate m <sup>3</sup> /h	Power input kW	Air flow rate m <sup>3</sup> /h	Power input kW	Air flow rate m <sup>3</sup> /h	Power input kW	Air flow rate m <sup>3</sup> /h	Power input kW	Air flow rate m <sup>3</sup> /h	Power input kW	Air flow rate m <sup>3</sup> /h	Power input kW	Air flow rate m <sup>3</sup> /h	Power input kW	Air flow rate m <sup>3</sup> /h	Power input kW
50	11500	1,7	11500	1,7	11000	1,65	10500	1,65	23000	3,4	23000	3,4	22000	3,3	21000	3,3
75	9600	1,65	9600	1,65	9200	1,6	8800	1,6	19200	3,3	19200	3,3	18400	3,2	17600	3,2
100	8500	1,6	8500	1,6	8100	1,55	7700	1,55	17000	3,2	17000	3,2	16200	3,1	15400	3,1
125	7200	1,55	7200	1,55	6900	1,5	6600	1,5	14400	3,1	14400	3,1	13800	3	13200	3
150	6400	1,5	6400	1,5	6100	1,5	5800	1,5	12800	3	12800	3	12200	3	11600	3

#### AVAILABLE STATIC PRESSURE UP TO 350 Pa - FP2 VERSION

MODELS	0251S-FP2		0291S-FP2		0351S-FP2		0431S-FP2		0472S-FP2		0552S-FP2		0672S-FP2		0812S-FP2	
Fan type	Axial "short case" - Direct coupling 1450 rpm 3~230V/3N~400V															
Fan number	1								2							
Available static pressure Pa	Air flow rate m <sup>3</sup> /h	Power input kW	Air flow rate m <sup>3</sup> /h	Power input kW	Air flow rate m <sup>3</sup> /h	Power input kW	Air flow rate m <sup>3</sup> /h	Power input kW	Air flow rate m <sup>3</sup> /h	Power input kW	Air flow rate m <sup>3</sup> /h	Power input kW	Air flow rate m <sup>3</sup> /h	Power input kW	Air flow rate m <sup>3</sup> /h	Power input kW
150	12400	2,45	12400	2,45	11900	2,4	11500	2,35	24800	4,9	24800	4,9	23800	4,8	23000	4,7
200	10800	2,3	10800	2,3	10400	2,3	10000	2,25	21600	4,6	21600	4,6	20800	4,6	20000	4,5
250	9200	2,3	9200	2,3	8800	2,3	8500	2,3	18400	4,6	18400	4,6	17600	4,6	17000	4,6
300	7800	2,4	7800	2,4	7500	2,4	7250	2,45	15600	4,8	15600	4,8	15000	4,8	14500	4,9
350	6800	2,45	6800	2,45	6500	2,45	6250	2,5	13600	4,9	13600	4,9	13000	4,9	12500	5

## 1.- GENERAL CHARACTERISTICS

### 1.2.- STANDARD UNIT ELECTRICAL DATA

EAC / EAR MODELS			0091S	0111S	0151S	0191S	0211S	0251S	0291S
Voltage	V/f (50 Hz)	1N~230V							
		3~230V - 3N~400V							
Maximum consumption	Compressor	<b>kW.</b>	4,05	4,70	5,78	7,60	8,62	11,15	12,90
	Fan motor	<b>kW.</b>	0,15	0,30	0,32	0,30	0,28	0,75	0,90
	Total power	<b>kW.</b>	4,20	5,00	6,10	7,90	8,90	11,90	13,80
Maximum current	Compressor	<b>A</b>	1N~230V 23,10						
			3~230V 12,12	17,32	21,48	27,71	26,15	31,17	35,85
			3N~400V 7,00	10,00	12,40	16,00	15,10	18,00	20,70
	Fan motor	<b>A</b>	0,80	1,60	1,60	1,60	1,60	3,00	3,50
Total current	<b>A</b>	1N~230V 23,90							
		3~230V 12,92	18,92	23,08	29,31	27,75	34,17	39,35	
		3N~400V 7,80	11,60	14,00	17,60	16,70	21,00	24,20	
LRC	Total current	<b>A</b>	1N~230V 95,80						
			3~230V 91,80	99,60	134,60	179,60	167,60	213,00	227,50
			3N~400V 44,30	51,60	63,60	97,40	95,60	119,00	130,50

### HYDRAULIC VERSION / HYDRONIC VERSION

Water pump			1N~230V			3~230V - 3N~400V		
Nominal absorbed intensity	<b>kW.</b>		0,49	0,49	0,49	0,72	0,72	0,72
Maximum current	<b>A</b>	1N~230V 2,30	2,30	2,30	2,30			
		3~230V 2,40				2,40	2,40	2,40
		3N~400V 1,40				1,40	1,40	1,40

EAC / EAR MODELS			0351S	0431S	0472S	0552S	0672S	0812S
Voltage	V/f (50 Hz)	3~230V - 3N~400V						
Maximum consumption	Compressor	<b>kW.</b>	15,55	19,77	22,10	25,50	30,90	38,14
	Fan motor	<b>kW.</b>	0,85	0,83	1,50	1,80	1,70	1,66
	Total power	<b>kW.</b>	16,40	20,60	23,60	27,30	32,60	39,80
Maximum current	Compressor	<b>A</b>	3~230V 44,34	51,61	62,35	71,70	88,68	103,22
			3N~400V 25,60	29,80	36,00	41,40	51,20	59,60
	Fan motor	<b>A</b>	3,50	3,50	6,00	7,00	7,00	7,00
	Total current	<b>A</b>	3~230V 47,84	55,11	68,35	78,70	95,68	110,22
LRC	Total current	<b>A</b>	3~230V 282,50	333,50	243,70	262,70	324,10	382,00
			3N~400V 161,50	192,50	138,00	152,30	187,00	222,00

### HYDRAULIC VERSION / HYDRONIC VERSION

Water pump			3~230V - 3N~400V					
Nominal absorbed intensity	<b>kW.</b>		1,10	1,10	1,17	1,17	1,55	1,55
Maximum current	<b>A</b>	3~230V 3,00	3,00	3,00	3,00	3,00	4,80	4,80
		3N~400V 1,70	1,70	1,70	1,70	1,70	2,80	2,80

## 1.- GENERAL CHARACTERISTICS

### 1.2.-HIGH STATIC PRESSURE UNIT ELECTRICAL DATA

### FP VERSION

EAC / EAR MODELS		0091S	0111S	0151S	0191S	0211S			
Voltage	V/f (50 Hz)	1N~230V	3~230V - 3N~400V						
Maximum consumption	Compressor	<b>kW.</b>	4,05	4,70	5,78	7,60	8,62		
	Fan motor	<b>kW.</b>	0,90	1,90	1,95	1,90	1,85		
	Total power	<b>kW.</b>	4,95	6,60	7,73	9,50	10,47		
Maximum current	Compressor	<b>A</b>	1N~230V	23,10					
			3~230V	12,12	17,32	21,48	27,71	26,15	
			3N~400V	7,00	10,00	12,40	16,00	15,10	
	Fan motor	<b>A</b>		4,00	8,00	8,00	8,00	8,00	
	Total current	<b>A</b>	1N~230V	27,10					
			3~230V	16,12	25,32	29,48	35,71	34,15	
			3N~400V	11,00	18,00	20,40	24,00	23,10	
LRC	Total current	<b>A</b>	1N~230V	99,00					
				3~230V	95,00	106,00	141,00	186,00	174,00
				3N~400V	47,50	58,00	70,00	103,80	102,00

### HYDRAULIC VERSION / HYDRONIC VERSION

Water pump		V/f (50 Hz)	1N~230V	3~230V - 3N~400V
Nominal absorbed intensity	<b>kW.</b>		0,49	0,49
Maximum current	<b>A</b>	1N~230V	2,30	2,30
		3~230V		2,40
		3N~400V		1,40

### FP1 VERSION

EAC / EAR MODELS		0251S	0291S	0351S	0431S	0472S	0552S	0672S	0812S
Voltage	V/f (50 Hz)	3~230V - 3N~400V							
Maximum consumption	Compressor	<b>kW.</b>	11,15	12,90	15,55	19,77	22,10	25,50	30,90
	Fan motor	<b>kW.</b>	1,70	1,70	1,65	1,65	3,40	3,40	3,30
	Total power	<b>kW.</b>	12,85	14,60	17,20	21,42	25,50	28,90	34,20
Maximum current	Compressor	<b>A</b>	3~230V	31,17	35,85	44,34	51,61	62,35	71,70
			3N~400V	18,00	20,70	25,60	29,80	36,00	41,40
	Fan motor	<b>A</b>		8,00	8,00	8,00	16,00	16,00	16,00
	Total current	<b>A</b>	3~230V	39,17	43,85	52,34	59,61	78,35	87,70
			3N~400V	26,00	28,70	33,60	37,80	52,00	57,40
LRC	Total current	<b>A</b>	3~230V	218,00	232,00	287,00	338,00	253,68	271,66
				3N~400V	124,00	135,00	166,00	197,00	148,00

### HYDRAULIC VERSION / HYDRONIC VERSION

Water pump		V/f (50 Hz)	3~230V - 3N~400V						
Nominal absorbed intensity	<b>kW.</b>		0,72	0,72	1,10	1,10	1,17	1,17	1,55
Maximum current	<b>A</b>	3~230V	2,40	2,40	3,00	3,00	3,00	3,00	4,80
		3N~400V	1,40	1,40	1,70	1,70	1,70	1,70	2,80



## 1.- GENERAL CHARACTERISTICS

### 1.2.- HIGH STATIC PRESSURE UNIT ELECTRICAL DATA

#### FP2 VERSION

EAC / EAR MODELS			0251S	0291S	0351S	0431S	0472S	0552S	0672S	0812S	
<b>Voltage</b>	<b>V/f (50 Hz)</b>		3~230V - 3N~400V								
<b>Maximum consumption</b>	Compressor	<b>kW.</b>	11,15	12,90	15,55	19,77	22,10	25,50	30,90	38,14	
	Fan motor	<b>kW.</b>	2,45	2,45	2,40	2,35	4,90	4,90	4,80	4,70	
	Total power	<b>kW.</b>	13,60	15,35	17,95	22,12	27,00	30,40	35,70	42,84	
<b>Maximum current</b>	Compressor	<b>A</b>	3~230V 3N~400V	31,17 18,00	35,85 20,70	44,34 25,60	51,61 29,80	62,35 36,00	71,70 41,40	88,68 51,20	103,22 59,60
	Fan motor	<b>A</b>	3~230V 3N~400V	8,00 4,50	8,00 4,50	8,00 4,50	8,00 4,50	16,00 9,00	16,00 9,00	16,00 9,00	16,00 9,00
	Total current	<b>A</b>	3~230V 3N~400V	39,17 22,50	43,85 25,20	52,34 30,10	59,61 34,30	78,35 45,00	87,70 50,40	104,68 60,20	119,22 68,60
<b>LRC</b>	Total current	<b>A</b>	3~230V 3N~400V	218,00 120,50	232,00 131,50	287,00 162,50	338,00 193,50	253,68 141,00	271,66 154,30	333,06 189,00	390,98 224,00

#### HYDRAULIC VERSION / HYDRONIC VERSION

<b>Water pump</b>	<b>V/f (50 Hz)</b>		3~230V - 3N~400V							
<b>Nominal absorbed intensity</b>	<b>kW.</b>		0,72	0,72	1,10	1,10	1,17	1,17	1,55	1,55
<b>Maximum current</b>	<b>A</b>	3~230V	2,40	2,40	3,00	3,00	3,00	3,00	4,80	4,80
		3N~400V	1,40	1,40	1,70	1,70	1,70	1,70	2,80	2,80

## 1.- GENERAL CHARACTERISTICS

### 1.3.- COMPONENT

The ECOLEAN™ system comprises a water cooler or air/water pump combined with a series of hydraulic accessories obtaining the hydraulic or hydronic version.

COMPONENT:

HYDRONIC VERSION: 1,2,3,4,5,6,7,8,9,10, 11

HYDRAULIC VERSION: 1,4,5,6,7,8,9,10,11

- |                                   |   |
|-----------------------------------|---|
| 1.- Detachable water filter       | 7.- Water pump                          |
| 2.- Water tank                    | 8.- Air purge valve                     |
| 3.- Water tank heater (in option) | 9.- Plate exchanger                     |
| 4.- Safety valve                  | 10.- Flow switch                        |
| 5.- Manometer                     | 11.- Drain valve                        |
| 6.- Expansion vessel              | 12.- Water isolation valves (in option) |

### HYDRONIC VERSION

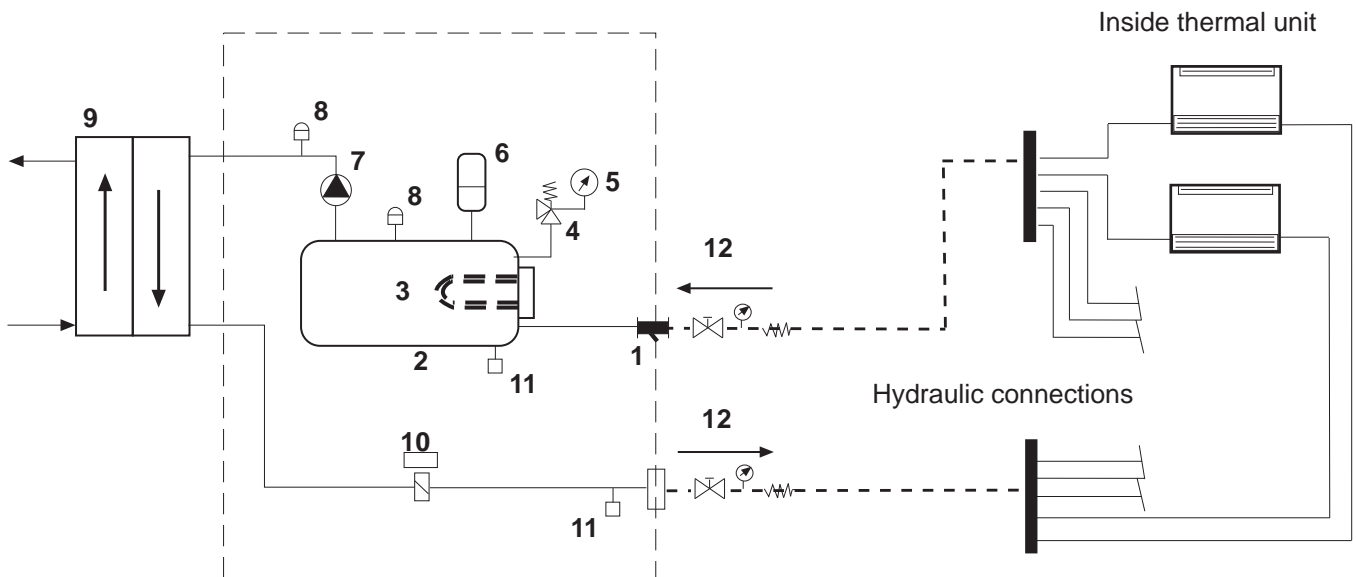

### HYDRAULIC VERSION

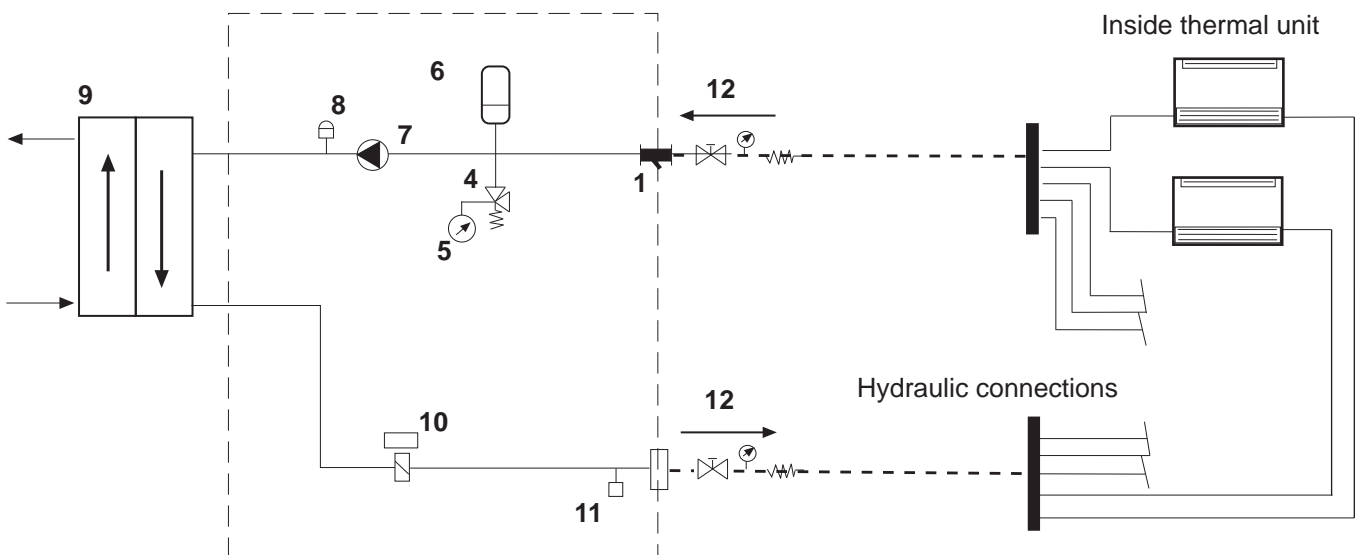

## 1.- GENERAL CHARACTERISTICS

### 1.4.- OPERATION LIMITS

#### STANDARD AXIAL FAN UNITS WITHOUT AIR DUCTS

##### COOLING MODE

MODELS	EAC / EAR	0091S	0111S	0151S	0191S	0211S	0251S	0291S	0351S	0431S	0472S	0552S	0672S	0812S
Outlet chilled water temperature		Minimum : +5°C Maximum : +12°C												
Inlet chilled water temperature		Minimum : +10 °C Maximum : +17°C												
Air inlet temperature	R-407C	Minimum : -5°C (1) Maximum : +46°C												
	R-22	Minimum : -5°C (1) Maximum : +48°C												

NOTE: With outdoor temperatures below +5°C, add glycol

(1) With the optional cooling low ambient kit (-5° to -15°C), it is possible the unit operation up to -15°C

##### HEATING MODE

MODELS	EAR	0091S	0111S	0151S	0191S	0211S	0251S	0291S	0351S	0431S	0472S	0552S	0672S	0812S
Hot water outlet temperature (operation)		Minimum : +20°C Maximum : +50°C												
Hot water inlet temperature (start)		Minimum : +10 °C Maximum : +43°C												
Difference hot water inlet/outlet		Minimum : +3°C Maximum : +8°C												
Air inlet temperature		Minimum : -10°C (2) Maximum : +23°C												

OUTSIDE THESE VALUES, PLEASE CONSULT US

(2) With the optional heating low ambient kit (-15°C), it is possible the unit operation up to -15°C

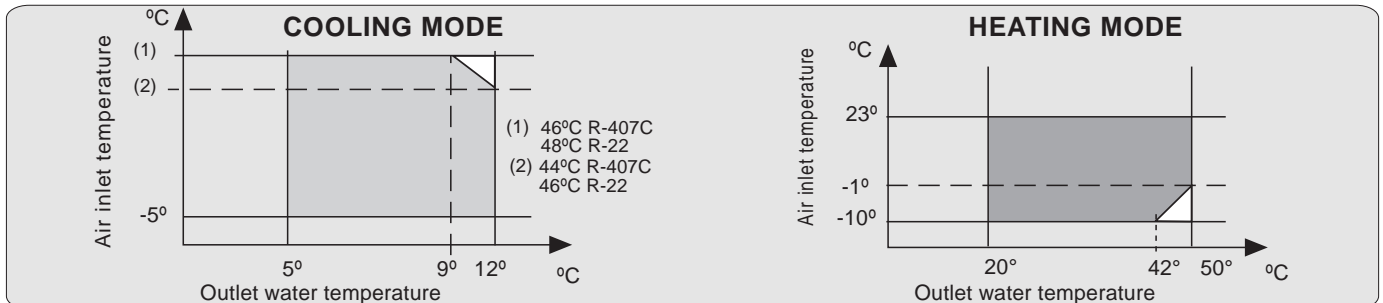

NOTE: With outdoor temperatures below +5°C, add glycol. The unit incorporates as standard a fan speed control in cooling mode, which allows the unit to operate at very low outside temperatures, until -5°C. If it is used the cooling low ambient kit (-5° to -15°C), it is possible the unit operation up to -15°C.

#### STANDARD AXIAL FAN UNITS WITH AIR DUCTS

##### COOLING MODE

AVAILABLE PRESSURE UP TO 50 Pa	0091 to 0211S		0251 to 0812S		0091 to 0211S		0251 to 0812S	
	R407C models				R22 models			
Available static pressure Pa	30	50	30	50	30	50	30	50
Maximum ambient temperature °C	43	40	42	38	46	44	45	43

##### HEATING MODE

AVAILABLE PRESSURE UP TO 50 Pa	0091 to 0211S		0251 to 0812S		0091 to 0211S		0251 to 0812S	
	R407C models				R22 models			
Available static pressure Pa	30	50	30	50	30	50	30	50
Minimum ambient temperature °C (1)	-8	-6	-8	-6	-8	-6	-8	-6

(1) With the optional heating low ambient kit (-15°C), it is possible the unit operation up to -15°C

## 1.- GENERAL CHARACTERISTICS

### 1.4.- OPERATION LIMITS

#### HIGH STATIC PRESSURE UNITS

#### COOLING MODE

##### AVAILABLE PRESSURE UP TO 200 Pa FP VERSION

	0091 to 0211S-FP MODEL UNITS							
	R407C models				R22 models			
	50	100	150	200	50	100	150	200
Available static pressure Pa	50	100	150	200	50	100	150	200
Maximum ambient temperature °C	46	45	41	38	48	47	44	42

##### AVAILABLE PRESSURE UP TO 120 Pa FP1 VERSION

	00251 to 0812S-FP MODEL UNITS									
	R407C models					R22 models				
	50	75	100	125	150	50	75	100	125	150
Available static pressure Pa	50	75	100	125	150	50	75	100	125	150
Maximum ambient temperature °C	46	43	39	35	---	50	48	45	43	40

##### AVAILABLE PRESSURE UP TO 350 Pa FP2 VERSION

	00251 to 0812S-FP MODEL UNITS									
	R407C models					R22 models				
	150	200	250	300	350	150	200	250	300	350
Available static pressure Pa	150	200	250	300	350	150	200	250	300	350
Maximum ambient temperature °C	47	44	41	38	35	50	48	46	44	42

#### HEATING MODE

##### AVAILABLE PRESSURE UP TO 200 Pa FP VERSION

	0091 to 0211S-FP MODEL UNITS							
	R407C models				R22 models			
	50	100	150	200	50	100	150	200
Available static pressure Pa	50	100	150	200	50	100	150	200
Minimum ambient temperature °C (1)	-10	-10	-8	-6	-10	-10	-8	-6

##### AVAILABLE PRESSURE UP TO 120 Pa FP1 VERSION

	00251 to 0812S-FP MODEL UNITS									
	R407C models					R22 models				
	50	75	100	125	150	50	75	100	125	150
Available static pressure Pa	50	75	100	125	150	50	75	100	125	150
Minimum ambient temperature °C (1)	-10	-8	-6	-5	---	-10	-10	-8	-6	-5

##### AVAILABLE PRESSURE UP TO 350 Pa FP2 VERSION

	00251 to 0812S-FP MODEL UNITS									
	R407C models					R22 models				
	150	200	250	300	350	150	200	250	300	350
Available static pressure Pa	150	200	250	300	350	150	200	250	300	350
Minimum ambient temperature °C (1)	-10	-10	-8	-6	-5	-10	-11	-10	-8	-6

(1) With the optional heating low ambient kit (-15°C), it is possible the unit operation up to -15°C

#### UNITS WITH LOW WATER TEMPERATURE KIT (OPTION)

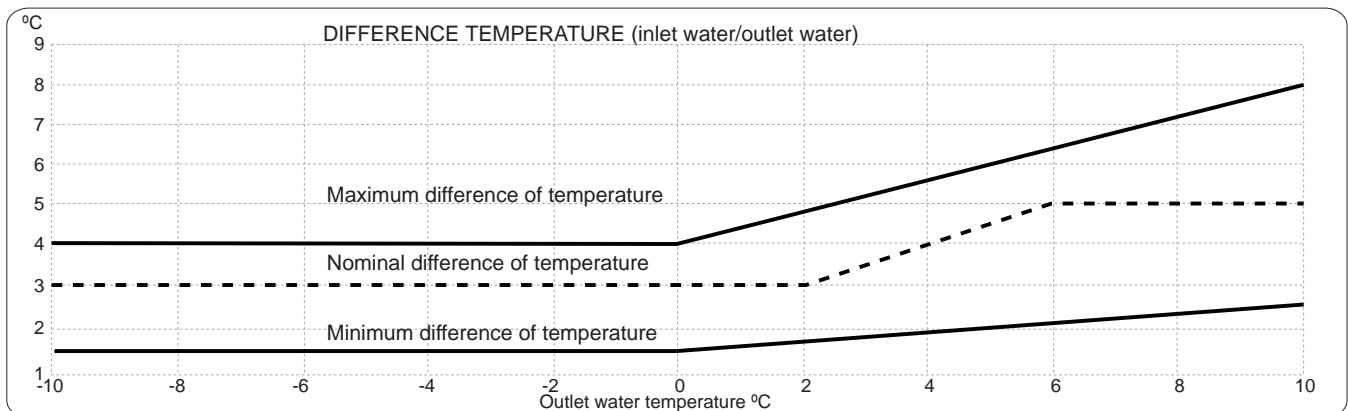

# 1.- GENERAL CHARACTERISTICS

## 1.5.-PRESSURE DROP IN THE WATER SYSTEM

**PRESSURE DROP IN WATER EXCHANGER (STANDARD UNIT)**

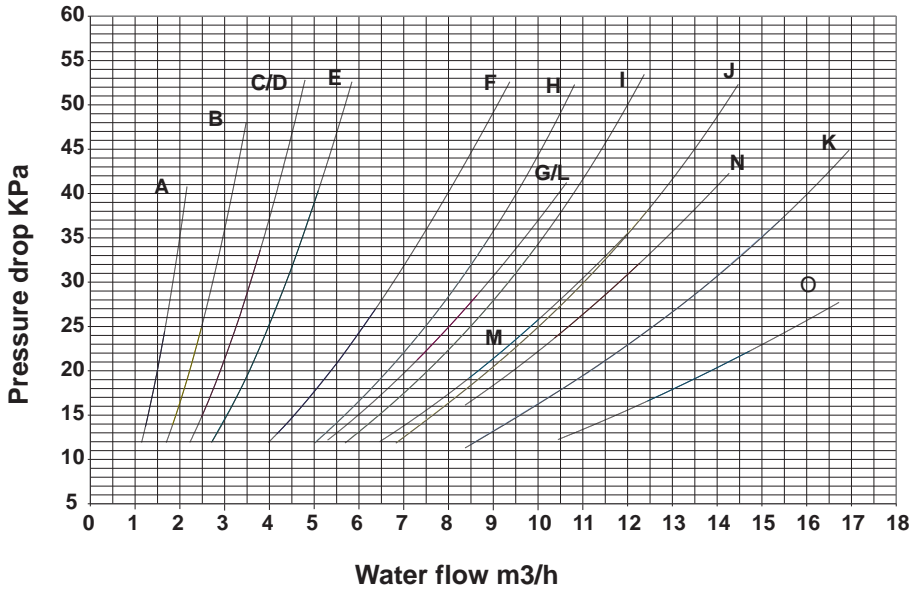

Unit	Curve
EAC/EAR 0091S	A
EAC/EAR 0111S	A
EAC/EAR 0151S	B
EAC/EAR 0191S	B
EAC/EAR 0211S	C
EAC/EAR 0251S	D
EAC/EAR 0291S	E
EAC/EAR 0351S	F
EAC/EAR 0431S	G
EAC 0472S	L
EAR 0472S	H
EAC 0552S	M
EAR 0552S	I
EAC 0672S	N
EAR 0672S	J
EAC 0812S	O
EAR 0812S	K

**PRESSURE DROP WATER EXCHANGER+WATER FILTER (\*)**

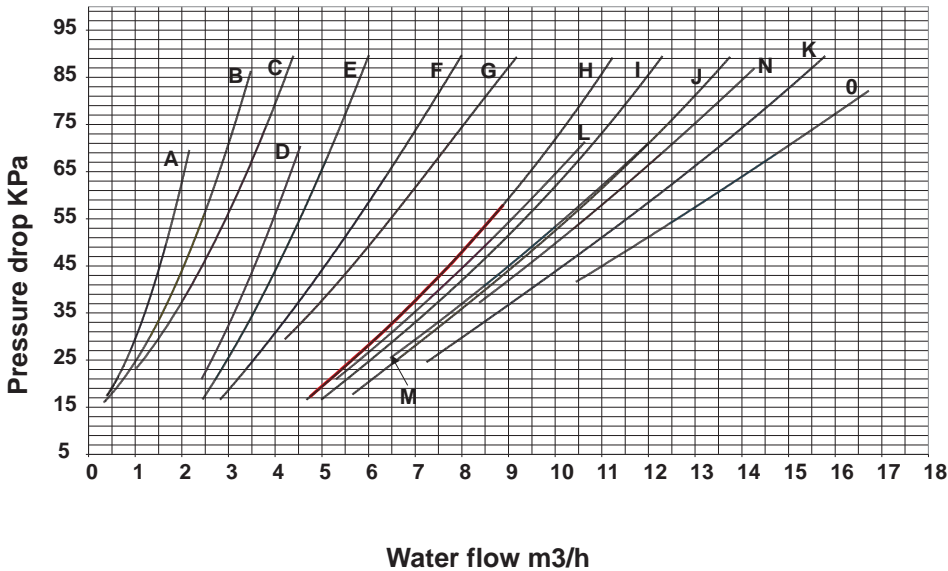

**INSTALLATION ADVISE**

The units **MUST** be fitted with a water filter at the inlet to the unit ( trapping any particles with a diameter greater than 1 mm.)

(\*) Optional in standard version and standard in hydronic and hydraulic version.

## 1.- GENERAL CHARACTERISTICS

### 1.6.-HYDRAULIC SYSTEM DATA.

WATER FLOW AND AVAILABLE STATIC PRESSURE (with standard water pump and filter, factory supplied)

	MODEL	EAC / EAR 009 1S K-A					EAC / EAR 011 1S K-A					EAC / EAR 015 1S K-A				
Water flow	l/s	0,33	0,37	0,41	0,45	0,49	0,41	0,45	0,49	0,53	0,60	0,49	0,53	0,57	0,61	0,72
	m3/h	1,19	1,33	1,48	1,62	1,76	1,48	1,62	1,76	1,91	2,16	1,76	1,91	2,05	2,20	2,59
Available static pressure	kPa	222	215	208	193	182	204	193	178	166	153	200	186	181	170	140

	MODEL	EAC / EAR 019 1S K-A					EAC / EAR 021 1S K-A					EAC / EAR 025 1S K-A				
Water flow	l/s	0,67	0,71	0,75	0,79	0,97	0,73	0,77	0,81	0,85	1,06	0,89	0,99	1,09	1,19	1,29
	m3/h	2,41	2,56	2,70	2,84	3,49	2,63	2,77	2,92	3,06	3,82	3,20	3,56	3,92	4,28	4,64
Available static pressure	kPa	181	175	168	160	139	184	176	165	155	128	182	162	143	132	115

	MODEL	EAC / EAR 029 1S K-A					EAC / EAR 035 1S K-A					EAC / EAR 043 1S K-A				
Water flow	l/s	1,02	1,12	1,22	1,32	1,49	1,26	1,36	1,46	1,56	1,83	1,52	1,62	1,72	1,82	2,21
	m3/h	3,67	4,03	4,39	4,75	5,36	4,54	4,90	5,26	5,62	6,59	5,57	5,83	6,19	6,55	7,96
Available static pressure	kPa	168	155	139	120	102	208	192	178	148	108	167	141	135	119	25

	MODEL	EAR 047 2S K-A					EAR 055 2S K-A					EAR 067 2S K-A				
Water flow	l/s	1,73	1,93	2,13	2,32	2,52	2,01	2,21	2,41	2,60	2,92	2,46	2,66	2,86	3,05	3,58
	m3/h	6,23	6,94	7,65	8,36	9,07	7,24	7,95	8,66	9,37	10,51	8,86	9,57	10,28	10,99	12,89
Available static pressure	kPa	164	149	138	123	113	151	141	132	116	97	227	213	192	169	119

	MODEL	EAR 081 2S K-A					EAC 047 2S K					EAC 055 2S K				
Water flow	l/s	2,95	3,15	3,35	3,54	4,30	1,73	1,93	2,13	2,32	2,52	2,01	2,21	2,41	2,60	2,92
	m3/h	10,62	11,33	12,04	12,75	15,48	6,23	6,94	7,65	8,36	9,07	7,24	7,95	8,66	9,37	10,51
Available static pressure	kPa	199	185	169	139	42	166	151	140	130	118	154	145	137	119	108

	MODEL	EAC 067 2S K					EAC 081 2S K				
Water flow	l/s	2,46	2,66	2,86	3,05	3,58	2,95	3,15	3,35	3,54	4,30
	m3/h	8,86	9,57	10,28	10,99	12,89	10,62	11,33	12,04	12,75	15,48
Available static pressure	kPa	229	214	195	173	126	205	192	177	148	55

NOTE: The flow data indicated in table are between a minimum and a maximum water flow  
With the twin pump kit, the available static pressure will decrease 5% from the data shown above

Unit conversion:

Pressure 1KPa = 1/9,8 m.c.a. = 0,01 bar

1 bar = 10 m.c.a. = 100 kPa

#### MINIMUM WATER FLOW

The installation never must operate with less than the minimum water flow (see table), since this can cause:

- i. - Freezing the water heat exchanger.
- ii. -The water exchanger gets dirty.

#### MAXIMUM WATER FLOW

See maximum water flow, indicated in table. Always assure a minimal  $\Delta T$  to the exchanger of 3K.

#### MAXIMUM WATER VOLUME IN THE INSTALLATION

The units with hydronic or hydraulic module include a expansion vessel.

The table below details the maximum water volume in the system.

Models	009/021	025/043	047/081
Solution	Water volume in liters		
Water	225	550	850
Water + 10% gyt	175	400	650
Water + 20% gyt	150	350	575
Water + 30% gyt	125	300	450
Water + 40% gyt	90	165	220

If the water volume in the system is greater than that detailed in the table it will be necessary to add additional expansion vessel(s).

## 1.- GENERAL CHARACTERISTICS

### 1.7.-SAFETY DEVICES



**It is strictly forbidden to change or remove a safety device.**

When a safety device is activated, qualified personnel must investigate the unit and rectify the problem.

**Note:** Before resetting a safety device, the cause of the problem must be found and rectified before the unit can be restarted.

The ECOLEAN™ units contain the following safety devices:

- 1.- Electrical safety devices.
- 2.- Cooling system safety devices.
- 3.- Water system safety devices.

They protect the unit's operation under both normal and abnormal conditions.

#### ELECTRICAL SAFETY DEVICES

The control system is protected against overloads and short circuits by a magnetic-thermal switch. The compressor is also protected against overloads and short circuits by an internal safety device and the external thermal relay. When the current drops below the set level, these devices are automatically enabled, except for the thermal relay which is manually enabled. The fan motors are also protected by an internal device. If the motor coil temperature reaches a set value, the isolator cuts the control circuit.

Units

ADJUSTMENTS		0091S	0111S	0151S	0191S	0211S	0251S	0291S	0351S	0431S	0472S	0552S	0672S	0812S	
Compressor fuses	A (1N-230V)	1X32	--	--	--	--	--	--	--	--	--	--	--	--	
	A (3-230V)	3X20	3X25	3X25	3X32	3X40	3X40	3X50	3X62	3X80	6x40	6x50	6x63	6x80	
	A (3N-400V)	3X10	3x16	3x16	3x20	3x20	3x25	3x25	3x32	3x40	6x25	6x25	6x32	6x40	
Water pump fuses	A (1N-230V)	1x6	1x6	1x6	--	--	--	--	--	--	--	--	--	--	
	A (3-230V)	--	--	--	3x6	3x6	3x6	3x6	3x6	3x6	3x6	3x6	3x6	3x6	
	A (3N-400V)	--	--	--	3x6	3x6	3x6	3x6	3x6	3x6	3x6	3x6	3x6	3x6	
Fan fuses	Standard	A (1N-230V)	--	--	--	--	--	--	--	--	1x16	1x16	1x16	1x16	
	FP	--	--	--	--	--	--	--	--	--	--	--	--	--	
	FP1	A (1N-230V)	--	--	--	--	--	1x10	1x10	1x10	1x10	1x20	1x20	1x20	
	FP2	A (3-230V)	--	--	--	--	--	3X10	3X10	3X10	3X10	6x10	6x10	6x10	6x10
		A (3N-400V)	--	--	--	--	--	3X16	3X16	3X16	3X16	6x16	6x16	6x16	6x16

#### COOLING SYSTEM SAFETY DEVICES

##### Pressure switches

To avoid high pressure in the cooling system liable to damage the unit, a high pressure switch, an electric (Push RESET in the controller to reset) safety device located in the top part of the cooling system, is incorporated. An automatic (electrical reset, if 2 sets in 1 hour occurs) low pressure switch in the bottom section of the system prevents the unit from operating under excessive low pressure conditions. The heating pump coolers have two low pressure switches because the minimum pressure in heating mode is much lower than in cooling mode. The low pressure switches are fitted with a time delay.

ADJUSTMENTS	SET	RESET	SET	RESET	
High switch pressostat (bar)	<b>28,7</b>	<b>24</b>	<b>28,7</b>	<b>24</b>	
Low switch pressostat heat cycle (bar)	<b>0,5</b>	<b>1,5</b>	<b>0,5</b>	<b>1,5</b>	
Low switch pressostat timer (minutes)	<b>2'</b>				
Low switch pressostat cool cycle (bar)	<b>Ambient temp. up to -5°C</b>		<b>Ambient temp. up to -15°C</b>		
	<b>Unit with low water temperature kit</b>				
		<b>1,8</b>	<b>2,7</b>	<b>0,5</b>	<b>1,5</b>
	0°C	<b>2</b>	<b>2,5</b>	<b>1,5</b>	<b>2</b>
	-5°C	<b>1,5</b>	<b>2</b>	<b>1</b>	<b>1,5</b>
-10°C	<b>0,8</b>	<b>1,3</b>	<b>0,5</b>	<b>1</b>	

## 1.- GENERAL CHARACTERISTICS

### 1.7.-SAFETY DEVICES

#### **WATER SYSTEM SAFETY DEVICES (included in units with hydraulic or hydronic module)**

These units contain various safety devices, in order to avoid the water reaches low temperatures so it may cause a damage to the system.

##### **1.- Flow switch (optional for standard unit)**

Stop the unit if water flow is under limits. Operating with water flow under limits is completely forbidden.

##### **2.- Water filter (optional for standard unit)**

The water filter protects the unit against particles getting inside the circuit. The units must be fitted with a water filter.



IT IS NECESSARY TO FIT A WATER FILTER IN THE INLET WATER OF THE UNIT

#### **3.- Anti-freeze protection**

This protection is activated by the control of the unit.

It comes ON when the outlet water temperature probe (ST2), located inside the water interchanger, measures a certain temperature and OFF when the outlet water temperature reaches set temperature as the following table shows:

	STANDARD UNIT (°C)	UNIT WITH LOW WATER TEMPERATURE KIT (°C)		
		0°C	-5°C	-10°C
Protection ON	+5°C	-2°C	-7°C	-12°C
Protection OFF	+6°C	0°C	-5°C	-10°C

When the protection is activated occurs as follow:

If the unit is on STAND-BY as the operating mode: the water pump comes on, along with electrical heater of evaporator and electrical heater of water tank (if included).



DO NOT TURN OFF THE POWER TO THE UNIT. WHEN THE POWER IS OFF THE ANTI FREEZE PROTECTION WILL NOT OPERATE.

- If the unit is operating on heating mode: feeds the electrical heater of water tank, the electrical heater of the water heat exchanger, and activates the hot gas injection valve (if the unit incorporates these optionals).
- If the unit is operating on cooling mode: feeds the electrical heater of water tank and the electrical heater of the water heat exchanger (if the unit incorporates these optionals).

#### **4.- Anti-freeze alarm**

This alarm activates when the outlet water temperature probe (ST2) measures a certain temperature, as a consequence the unit goes off, as the following table shows:

	STANDARD UNIT (°C)	UNIT WITH LOW WATER TEMPERATURE KIT (°C)		
		0°C	-5°C	-10°C
Alarm ON	+3°C	-3°C	-8°C	-13°C

#### **OTHER PROTECTIONS**

##### **Compressor crank case heater**

Located around compressor, this protection is activated when the compressor stops, to maintain the compressor oil temperature preventing the refrigerant diluting into the compressor oil.



DO NOT TURN OFF THE POWER TO UNIT, SO THIS PROTECTION CAN OPERATES.



# 1.- GENERAL CHARACTERISTICS

## 1.8.-PIPING DRAWINGS

### COOLING ONLY UNITS EAC 0091S A 0431S

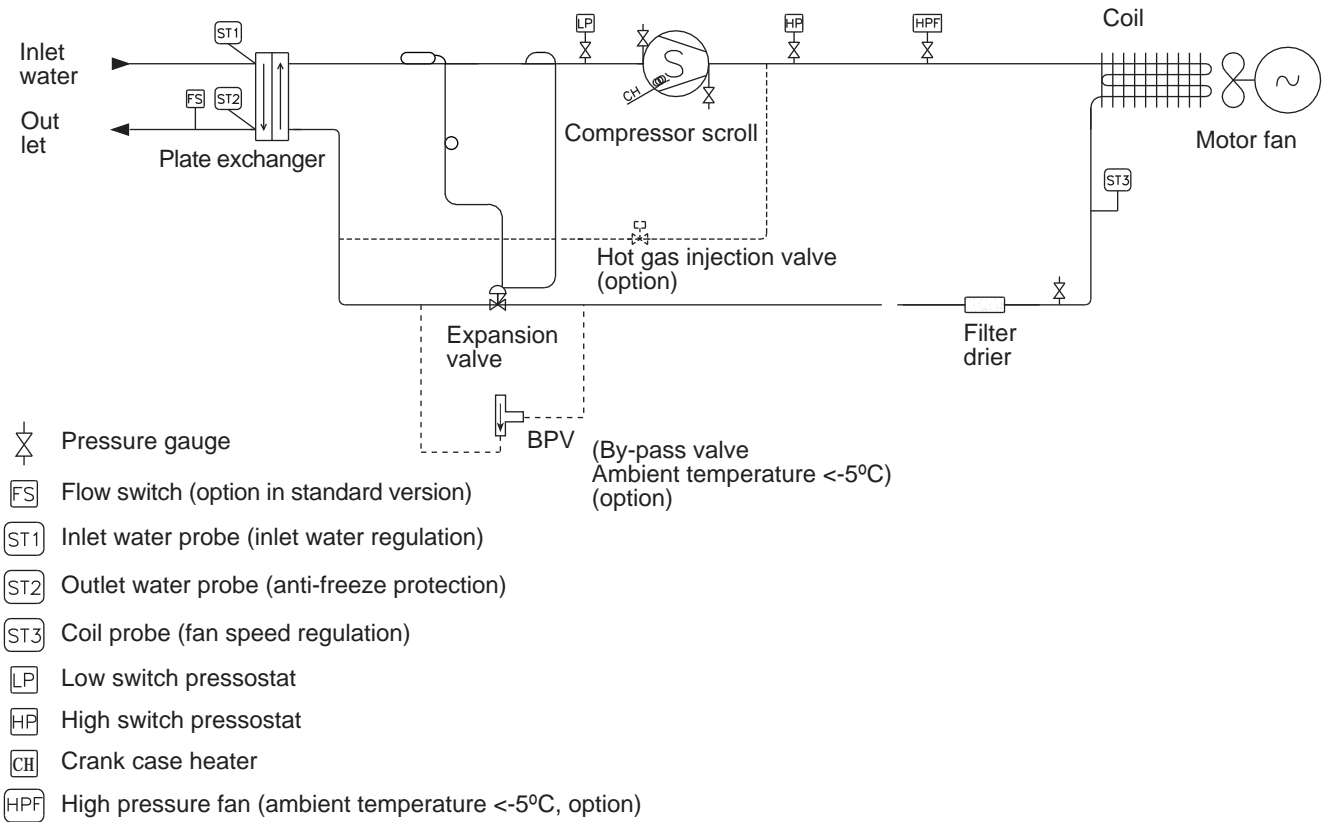

### COOLING ONLY UNITS EAC 0472S A 0812S

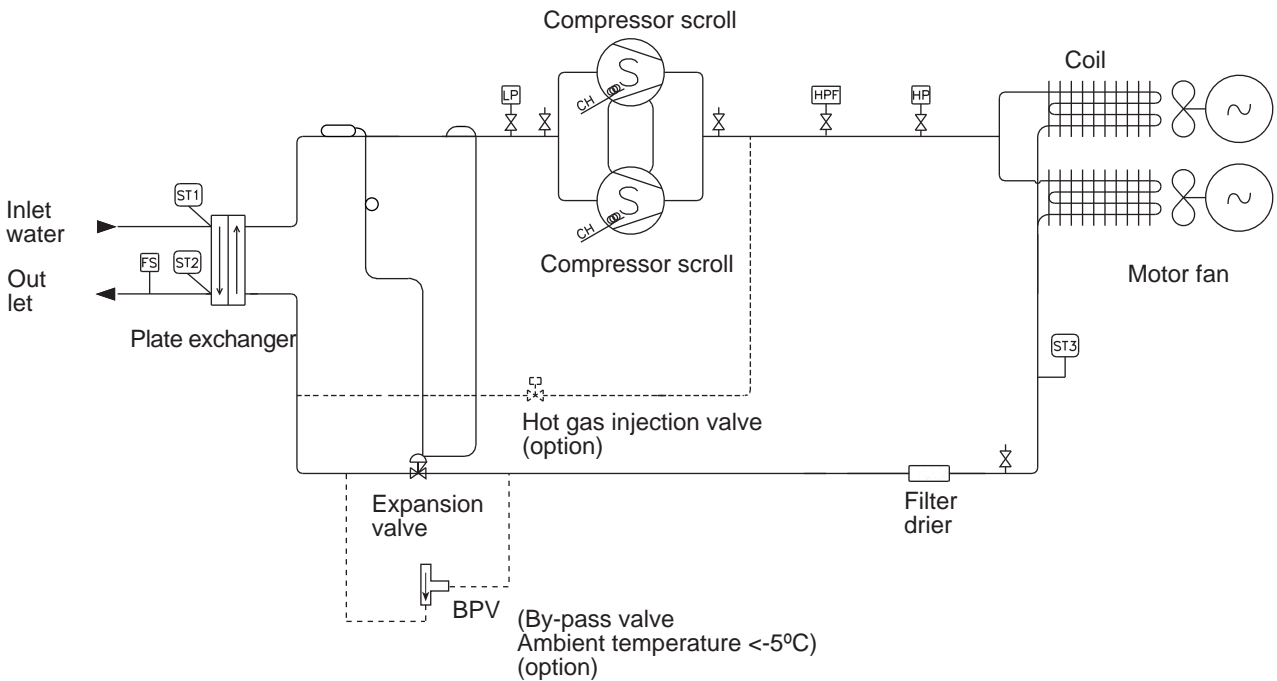

# 1.- GENERAL CHARACTERISTICS

## 1.8.-PIPING DRAWINGS

### HEAT PUMP UNITS EAR 0091S A 0431S

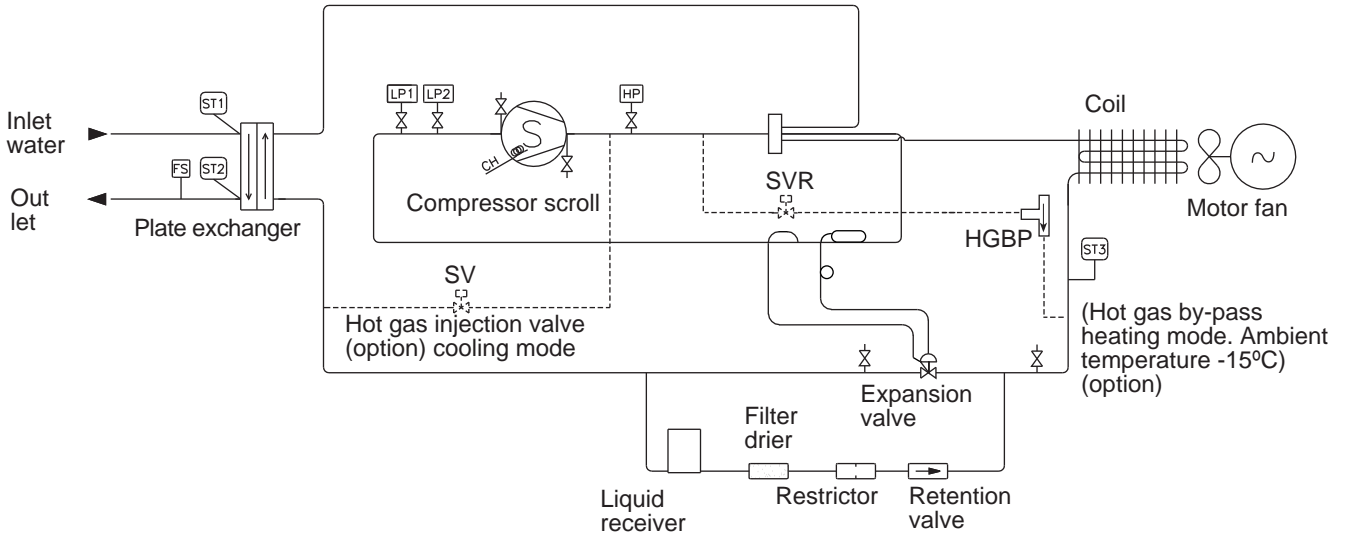

- |     |   |       |   |
|-----|---|-------|---|
| ⊗   | Pressure gauge  | LP1-1 | Low switch pressostat cooling cycle circuit 1 |
| FS  | Flow switch (option in standard version)                                | LP1-2 | Low switch pressostat heating cycle circuit 1 |
| ST1 | Inlet water probe (inlet water regulation)                              | LP2-1 | Low switch pressostat cooling cycle circuit 2 |
| ST2 | Outlet water probe (anti-freeze protection)                             | LP2-2 | Low switch pressostat heating cycle circuit 2 |
| ST3 | Coil probe circuit 1 (fan speed regulation and defrost heat pump units) | HP    | High switch pressostat                        |
| ST6 | Coil probe circuit 2 (fan speed regulation and defrost heat pump units) | HP1   | High switch pressostat circuit 1              |
| LP1 | Low switch pressostat cooling cycle                                     | HP2   | High switch pressostat circuit 2              |
| LP2 | Low switch pressostat heating cycle                                     | HPD1  | End defrost pressostat circuit 1              |
| CH  | Crank case heater   | HPD2  | End defrost pressostat circuit 2              |

### HEAT PUMP UNITS EAR 0472S A 0812S

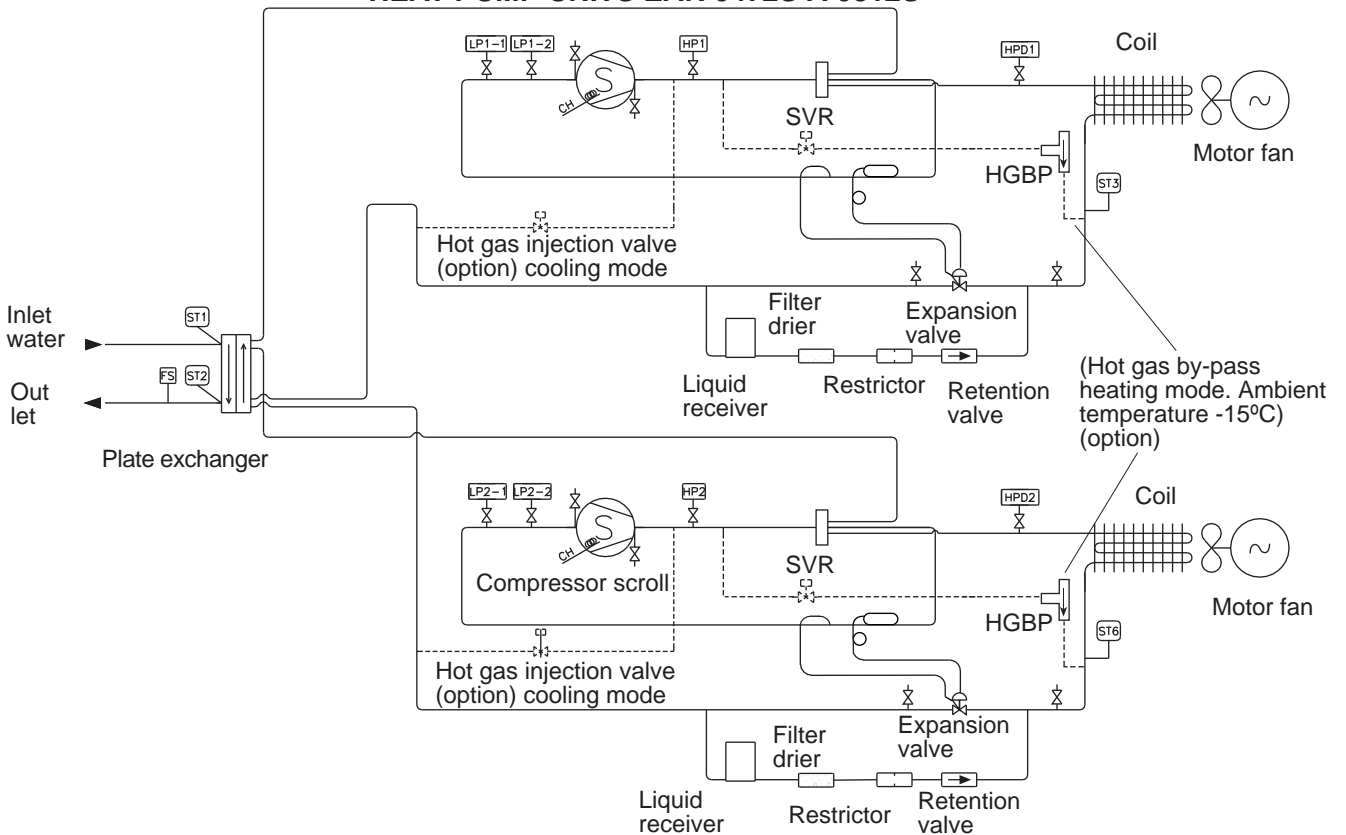

# 1.- GENERAL CHARACTERISTICS

## 1.9.- DIMENSIONS

**EAC/EAR  
0091S**

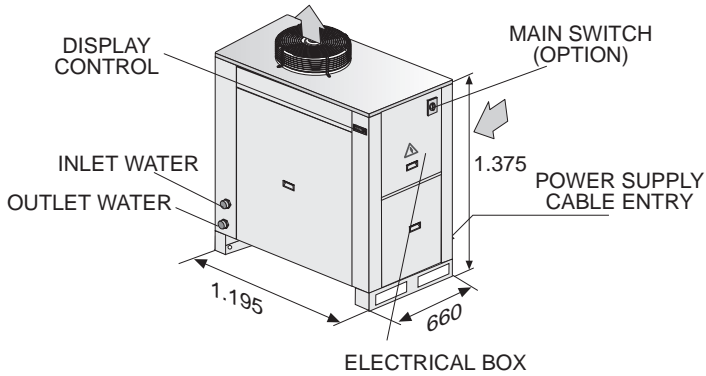

**COMPONENT DISPOSITION  
STANDARD UNIT**

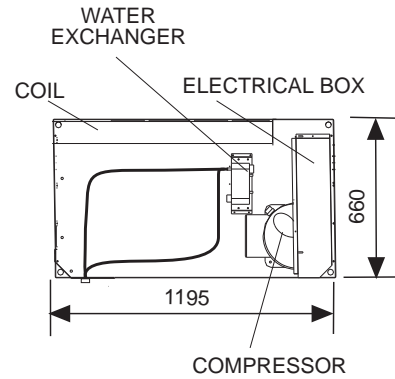

**EAC/EAR  
0091S FP**

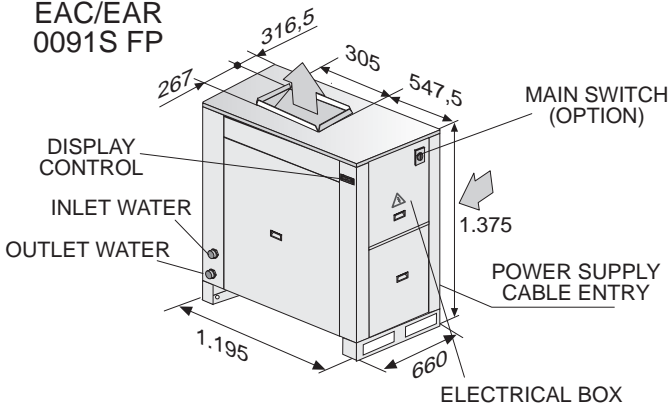

**COMPONENT DISPOSITION  
STANDARD UNIT WITH  
HYDRAULIC MODULE**

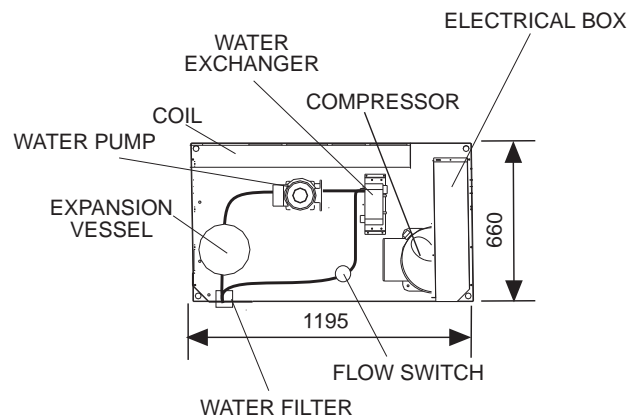

**EAC/EAR  
0111S-0151S-0191S-0211S**

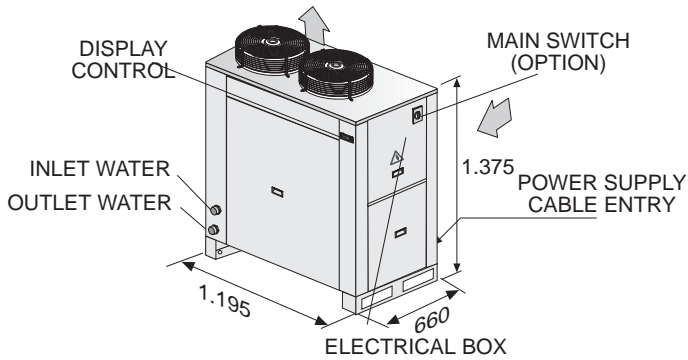

**COMPONENT DISPOSITION  
STANDARD UNIT WITH  
HYDRONIC MODULE**

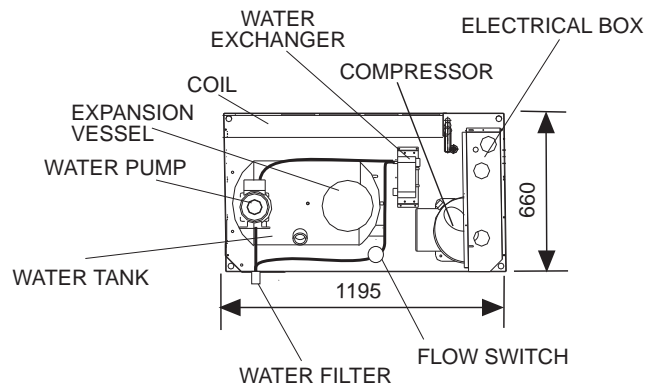

**EAC/EAR  
0111S-0151S-0191S-0211S FP**

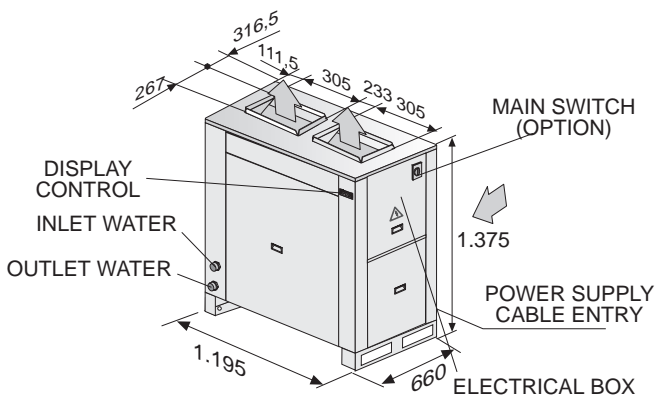

# 1.- GENERAL CHARACTERISTICS

## 1.9.- DIMENSIONS

EAC/EAR  
0251S-0291S-0351S-0431S FP1/FP2

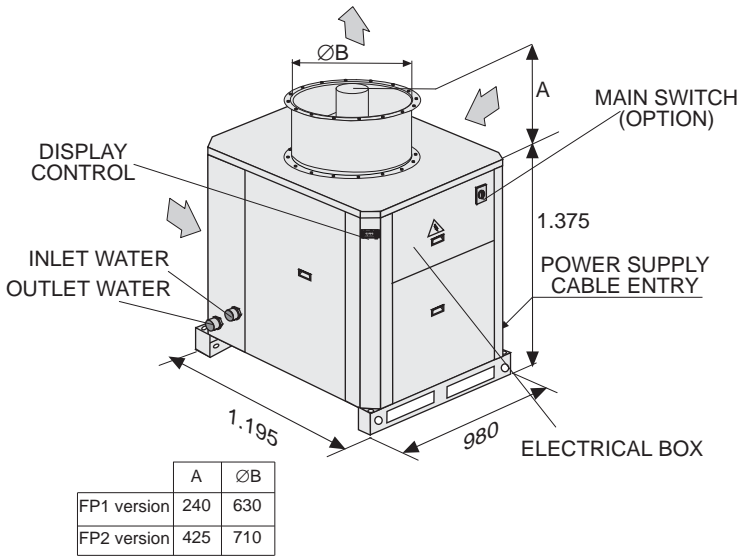

COMPONENT DISPOSITION  
STANDARD UNIT

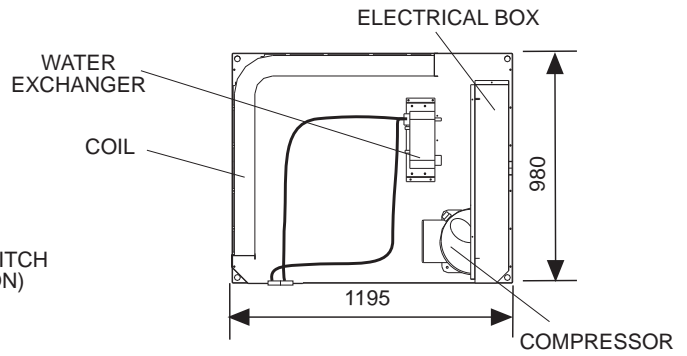

COMPONENT DISPOSITION  
STANDARD UNIT WITH  
HYDRAULIC MODULE

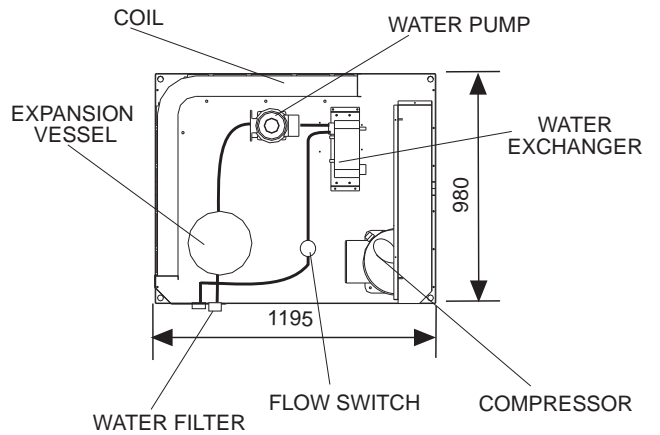

EAC/EAR  
0251S-0291S-0351S-0431S

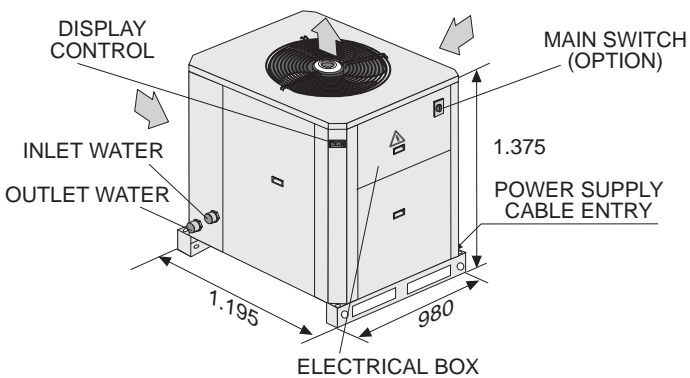

COMPONENT DISPOSITION  
STANDARD UNIT WITH  
HYDRONIC MODULE

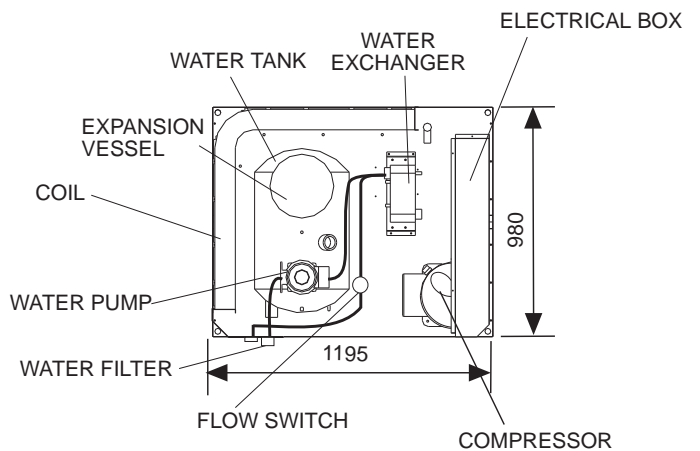

# 1.- GENERAL CHARACTERISTICS

## 1.9.- DIMENSIONS

**EAC/EAR**  
0472S-0552S-0672S-0812S

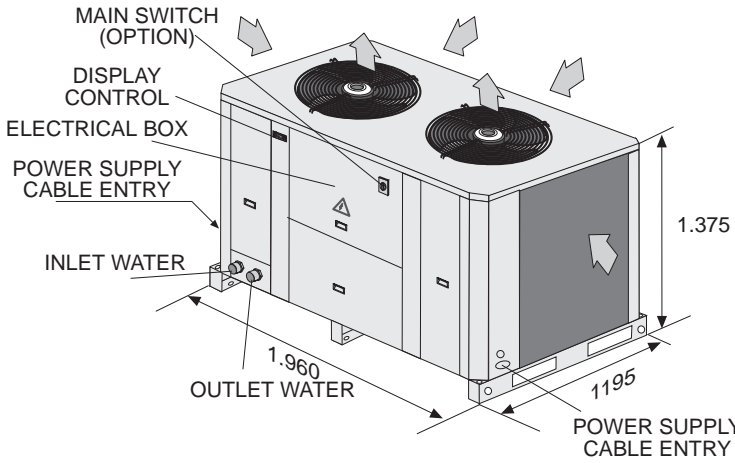

**COMPONENT DISPOSITION  
STANDARD UNIT**

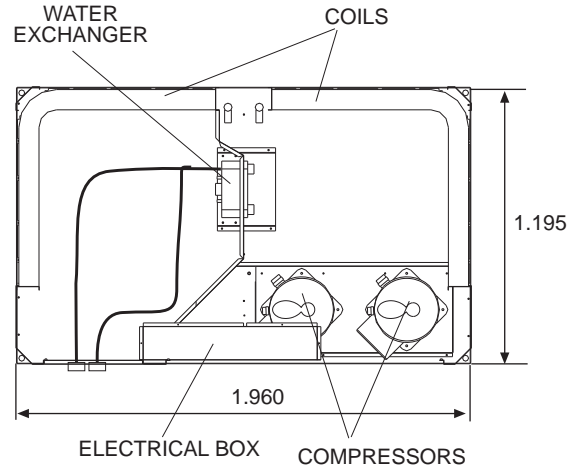

**COMPONENT DISPOSITION  
STANDARD UNIT WITH  
HYDRAULIC MODULE**

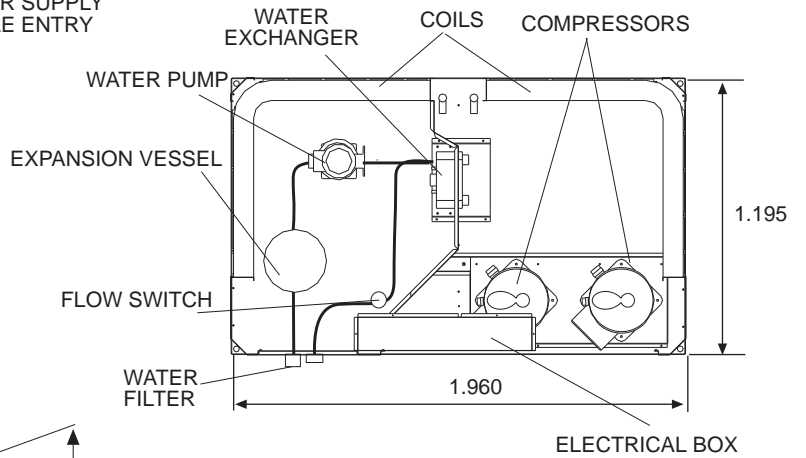

**EAC/EAR**  
0472S-0552S-0672S-0812S FP1/FP2

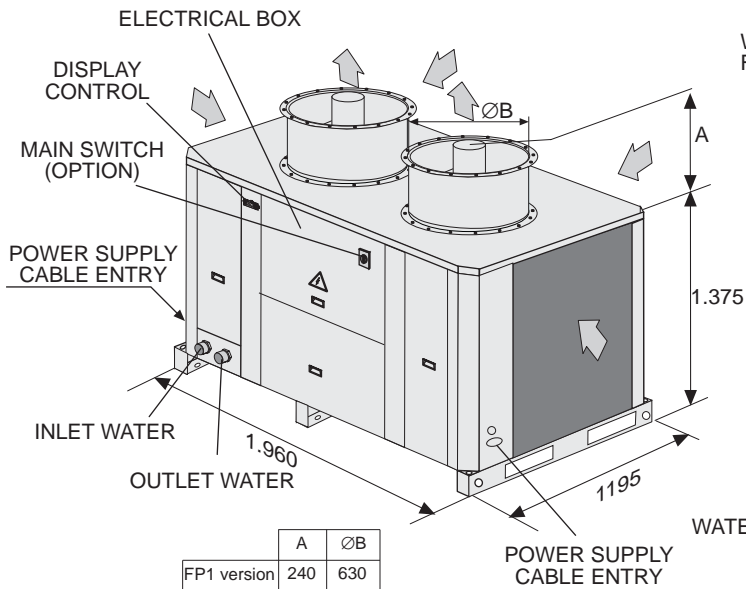

	A	ØB
FP1 version	240	630
FP2 version	425	710

**COMPONENT DISPOSITION  
STANDARD UNIT WITH  
HYDRONIC MODULE**

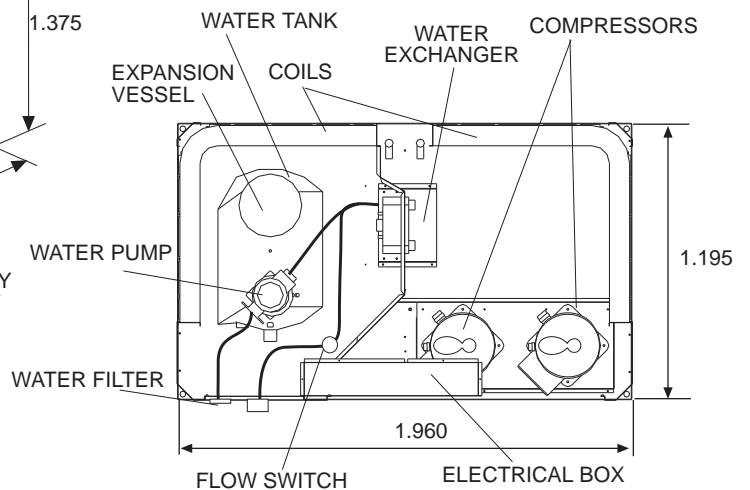

## 1.- GENERAL CHARACTERISTICS

### 1.10.- OPTIONALS

	Standard version unit	Hydraulic version unit	Hydronic (1) version unit
Main switch	X	X	X
Flow switch	X	included	included
Water filter	X	included	included
Evaporator anti freeze heater	X	X	X
Condenser coil guard	X	X	X
Hot gas injection valve	X	X	X
Phase protection	X	X	X
Gauges	X	X	X
Precoated coil	X	X	X
Remote controller	X	X	X
Water isolation valves	X	X	X
Rubber antivibration mounts	X	X	X
Kit low noise	X	X	X
"Soft starter" only 3N-400V units	X	X	X
Air intake plenum	X	X	X
Discharge plenum (2)	X	X	X
Operating unit with low water temperature	X	X	X
Water pump	X	included	included
Twin pumps	not available	X	X
Water tank electrical heater	not available	not available	X
Heating low ambient kit (-15°C)	X	X	X
Cooling low ambient kit (-15°C)	X	X	X

X Optional element

(1) Water tank included

(2) Only versions FP1/FP2



NOTE: All the optional will be supplied and mounted in the unit, except the water filter, water isolation valves, rubber antivibration mounts, remote controller and air intake plenum supplied to mount in the moment of installation.

#### MAIN SWITCH

Located at the electrical box of the unit.

#### FLOW SWITCH (included on hydraulic and hydronic versions)

The flow switch stops the unit if water flow is lower than the minimum.

#### WATER FILTER (included on hydraulic and hydronic versions)

The water filter must be fitted in the inlet water of the unit, it protects the unit against particles (greater than 1 mm) getting inside the water circuit, and prevents the water interchanger gets dirty.

#### EVAPORATOR ANTI FREEZE HEATER

The evaporator anti freeze heater prevents the water exchange from low temperatures.

#### CONDENSER COIL GUARD

The condenser coil protection grill prevents light damage to the coil when shipping and when installed. It cannot protect against very heavy impacts.

#### HOT GAS INJECTION VALVE

Supplies hot gas which is injected into the evaporator gas to increase the suction pressure if the chilled water temperature falls to low. It can be used to allow the unit to operate at reduced capacity, if the water temperature falls below the set point (5°C). It is controlled via the microprocessor controller ON at (5°C) and OFF (6°C) for example. This option is NOT available for units selected with low water temperature option (example only).

#### THREE PHASE PROTECTION

Located at the electrical box of the unit, it assures that unit will not begin operation if connection phases of compressor are not correct. Should this occur, then just switch two phase connections.

#### GAUGES

Visualize the high and low pressures of the refrigerant circuit.

#### PRECOATED COIL

Special protection of the aluminium condenser coil fins, to protect it from aggressive external environmental conditions.

#### REMOTE CONTROLLER

Controls and visualizes the unit's operating, it may be installed until 50 m from the unit.

#### HEATING LOW AMBIENT (-15°C) KIT

The reverse unit can operate in heating mode up to an ambient temperature of -15°C (standard unit just can operate up to -10°C).

#### COOLING LOW AMBIENT (-15°C) KIT

The cooling only unit can operate up to an ambient temperature of -15°C (standard unit just can operate up to -5°C).

## 1.- GENERAL CHARACTERISTICS

### 1.10.- OPTIONALS

#### WATER ISOLATION VALVES

To fit at inlet and outlet water of the unit. Isolating the unit from water circuit, so service and maintenance of the unit will be easier.

#### RUBBER ANTIVIBRATION MOUNTS

To install under the unit, to avoid transmission of vibrations, to the floor where unit is installed, while unit is operating.

#### COMPRESSOR ACOUSTIC JACKET

Each compressor is fitted with a compressor acoustic jacket this provides attenuation of the compressor noise that radiates from the unit when in operation.

#### SOFT STARTER (for 3N~400V units only)

It is an electronic element, which reduces the peak compressor starting current up to 40%.

#### AIR INTAKE PLENUM (models from 0251 to 0812 only)

It is a accessory for adapting the condenser air intake to accept a duct.

#### AIR DISCHARGE PLENUM (FP1 and FP2 unit versions and models from 0251 to 0812 only)

It is formed by 1 or 2 square frames, for adapting discharge air from the unit to a square duct.

#### 025 to 043 MODELS

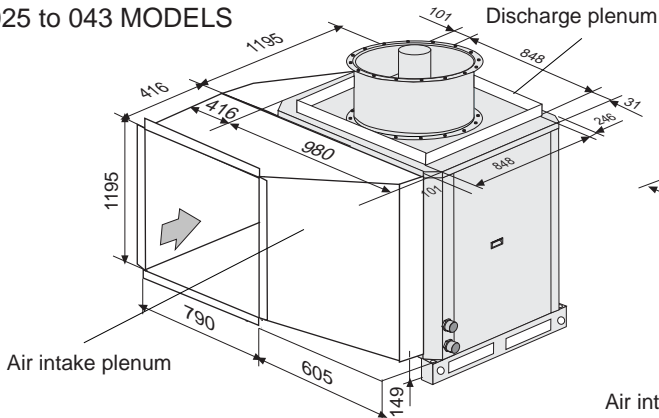

#### 047 to 081 MODELS

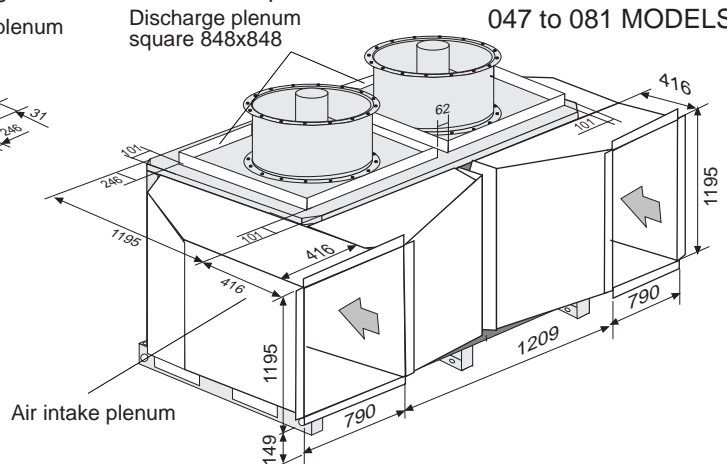

#### LOW WATER TEMPERATURE

Necessary for outlet water temperatures below +5°C

There are three different kits, which depend for selecting on the outlet water temperature desired, as the following table shows:

Denomination	Application duty on the outlet water temperature
KIT LOW WATER TEMPERATURE 0°C	For water temperatures below 5°C to 0°C
KIT LOW WATER TEMPERATURE -5°C	For water temperatures below 0°C to -5°C
KIT LOW WATER TEMPERATURE -10°C	For water temperatures below -5°C to -10°C

#### WATER PUMP (included on hydraulic and hydronic versions).

#### TWIN PUMPS KIT (models from 0251 to 0812 only)

It is formed by two-water pump mounted on parallel and with same characteristics as the single one. Only one pump is working, the other remains on stand by.

When the water pump which is operating cuts out, and the pump turns off, starting automatically the water pump on stand by.

It is possible to select which one of the pumps we want to be working through an external switch supplied with the kit.

With the twin pumps, the available static pressure will decrease 5% from the available static pressure with one water pump only.

**ANTI-FREEZE HEATER AND SUPPLEMENTARY** (available only for hydronic version): an immersion heater can be supplied complete with safety thermostat and pressostat fitted in the buffer tank, or an anti-freeze and supplementary heater (heat pump units only).

Anti-freeze heater: cooling only and heat pump units. It starts when water temperature in the buffer tank is lower than + 5 °C (Not for units with low water temperature kit).

Anti-freeze and supplementary heater: heat pump units only. The heater works as anti-freeze heater as explained before and as supplementary heater, when inlet warm water reaches a temperature below a value selected (example: 30 °C) through an independent thermostat included.

The power input is:

Models	009/021	025/043	047/081
Voltage	1N~230V		
	3~230V - 3N~400V		
Anti-freeze heater	2,25	2,25	2,25
(*) Heat pump units only	6	9	12

## 2.- INSTALLATION

### 2.1.- PRELIMINARY PREPARATIONS



**All INSTALLATION, SERVICE and MAINTENANCE operations must be carried out by QUALIFIED PERSONNEL.**

The unit must be transported in a **HORIZONTAL POSITION** on its metal bedplate profiles . Any other position may cause serious damage to the machine.

When the unit is received, it should be checked to assure that there are no bumps or other damage, following the instructions on the packaging. If there is damage, the unit may be rejected by notifying the LENNOX Distribution Department and reporting why the machine is unacceptable on the transport agent's delivery notice. Any later complaint or claim made to the LENNOX Distribution Department, for this type of anomaly, cannot be considered under the Guarantee.

Sufficient space must be allowed to facilitate placement of the unit. The unit may be mounted outdoors. There should be **NO** possibility of flooding if floor mounted.



**When positioning the unit, be sure that the Rating Plate will always be visible since this data will be necessary to assure proper maintenance.**

It is advisable to unpack the unit at the place where the unit is going to be installed, to avoid damages during manage.

### 2.2.- UNIT RECEPTION

#### How to hoist the unit

If unloading and placement require the use of a crane, then secure the suspension cables as shown in the figure. The unit can only be lifted and moved by its base.

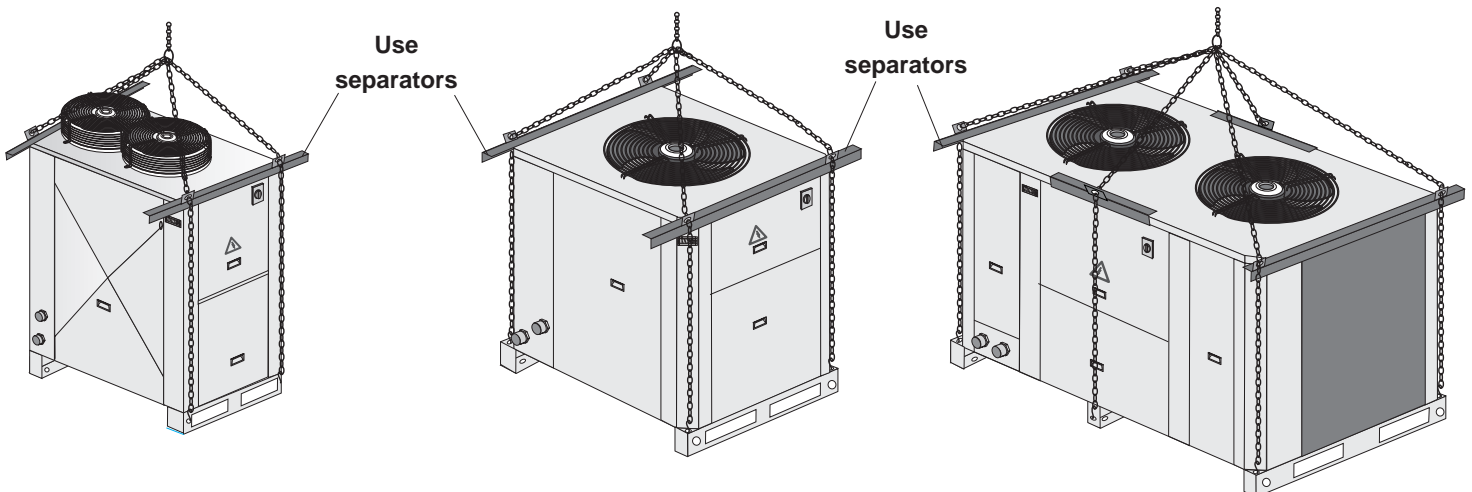



## 2.- INSTALLATION

### 2.3.- INSTALLATION CLEARANCES

(\*) Clearance around the unit for service and maintenance, for all unit versions.

#### INSTALLATION CLEARANCES

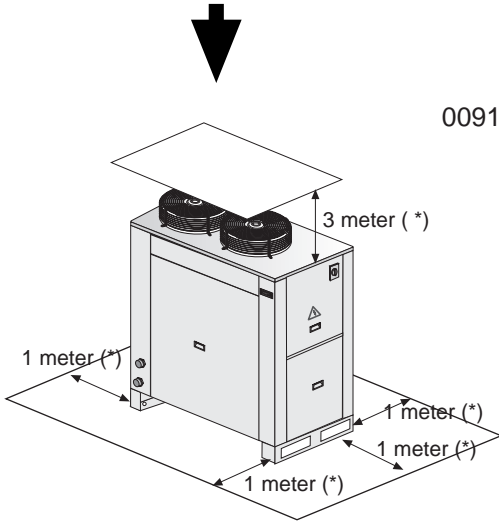

EAC/EAR  
0091S-0111S-0151S-0191S-0211S

#### MOUNTING PLATES

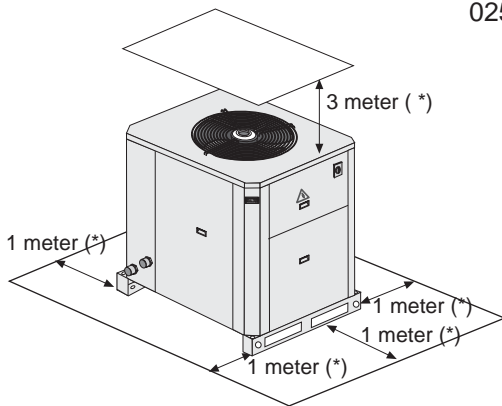
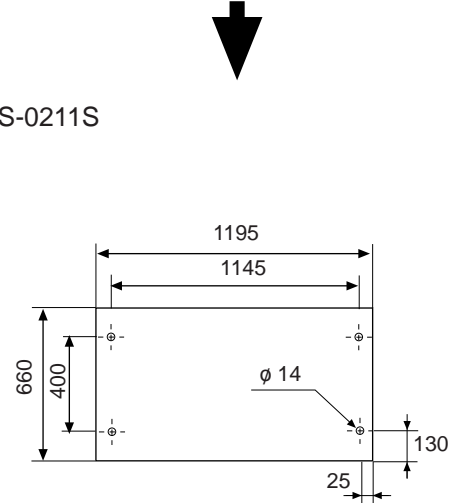

EAC/EAR  
0251S-0291S-0351S-0431S

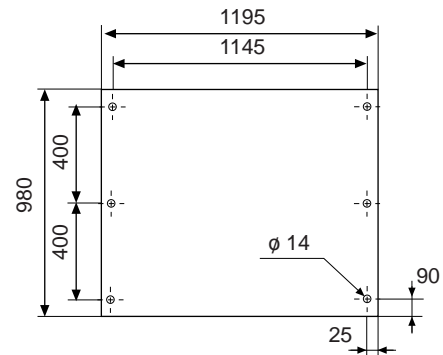

EAC/EAR  
0472S-0552S-0672S-0812S

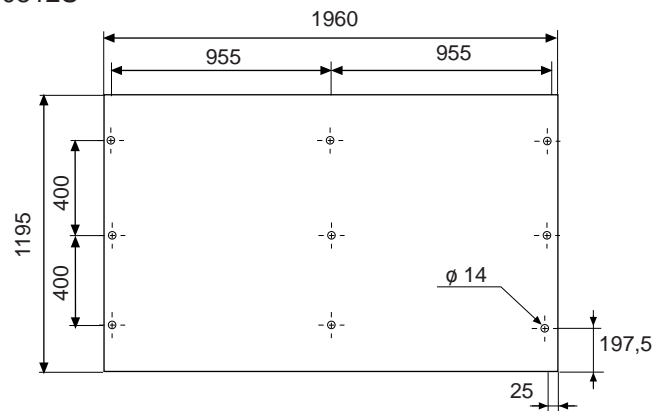
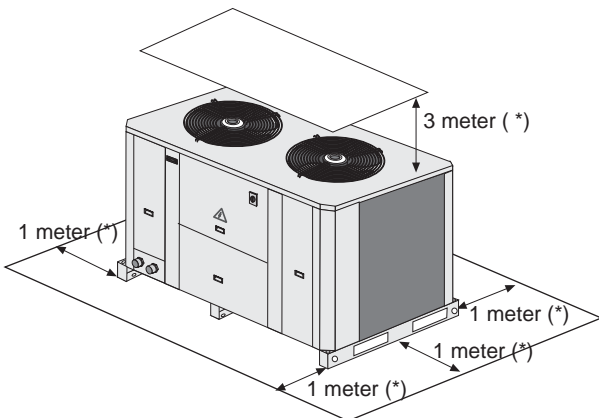

sizes in mm

## 2.- INSTALLATION

### 2.4.- UNIT INSTALLATION

- 1.- The ECOLEAN™ units could be installed outside or inside.
- 2.- See the minimum clearance diagrams for access - air supply to the batteries in the heating section of the unit. (see page 23)
- 3.- Assemble the unit on a resistant base, preferably concrete. To prevent vibrations, the concrete base should not come into contact with the building's foundations.
- 4.- It is advisable to assemble the unit on shock absorbers (antivibration mountings).
- 5.- During heating mode (heating pump coolers) ice forms in the coils. The defrost process is activated during heating mode in heat pump units, when the outside temperature is low and the outdoor coil could become frozen.

To melt the ice, the defrost function will switch the unit to cooling operation for a short period. When the evaporation temperature starts to drop, a defrost period sets in to provide sufficient heat transfer. During defrosting, the ice melts from the batteries. As a result, the ice contains water which must be removed.



If the outside temperature in the area where the unit is to be installed is likely to drop below 0°C, it may be necessary to install an electrical heater below the coils, which avoids the causing of ice in the coil.

- 6.- The water flow during cooling must be the same as during heating.
- 7.- Fit a water filter in the unit inlet



It is obligatory to install a mesh filter in units not equipped with hydronic or hydraulic module. The step of the mesh should not be superior to 1 mm.

- 8.- Use a decalcifying agent if necessary.
- 9.- The inlet water to the circuit has to be filled from lowest point, with purges opened, to prevent air being trapped.
- 10.- Location inside:

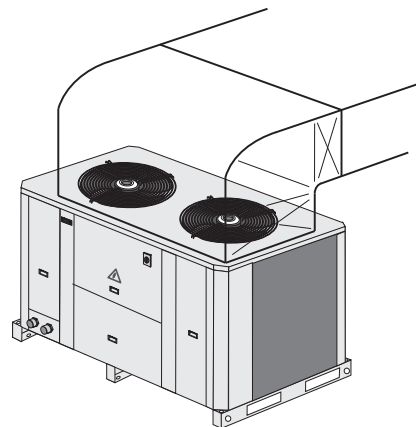
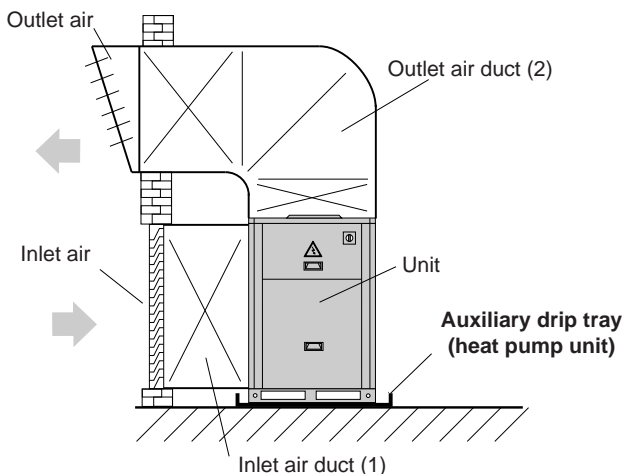

In heat pump units with double circuits, if only one duct is going to be installed, a regulated pressure damper should be installed for each fan, to avoid air by-pass through the fan if it has stopped.

For location inside, keep in mind following advice:

-In heat pump units during defrost cycle, the units produce a great amount of water melting the ice off coils.

If you wish to drain the water, an auxiliary drip tray should be installed behind the unit to collect and carry out the water where desired.

-Air duct installation:

If air duct has been installed, the operating limits get reduced (see operation limits section in this manual).

(1) The air intake plenum (option) available for models from 0251 to 0812 makes easier the installation of the air intake duct (see page 21).

(2) The discharge plenum (option) lets the installation of a square discharge duct for the high static pressure units FP1 and FP2 (see page 21).

## 2.- INSTALLATION

### 2.4.- UNIT INSTALLATION

#### IMPORTANT



If the outside temperature in the area where the ECOLEAN™ unit is to be installed is likely to drop below 5°C, it is very important to take the following precautions to avoid that water in the circuit freezing, that may produce damage to the components.

-If unit has to work under low outside temperatures:

\* Do not disconnect power supply in order that water pump starts when detects water temperatures below +5 °C (only hydraulic and hydronic models).

\* If the outside temperature where the system is to be installed or the outlet water temperature is likely to drop below 5°C, it is very important to use glycol anti-freeze.

The amount of anti-freeze required will vary depending on the minimum ambient temperature or the outlet water temperature.

When the percentage of glycol increases the standard pump flow decreases, the pressure drop increases and the cooling and thermal capacities drop. As a result the minimum flow must be multiplied by the coefficient shown in the table:

MINIMUM AMBIENT TEMPERATURE OR OUTLET WATER TEMPERATURE	ETHYLENE GLYCOL %	PRESSURE DROP	WATER FLOW	CAPACITIES	
				COOL	HEAT
FROM +5°C TO 0°C	10 %	1,05	1,02	0,99	0,994
FROM 0°C TO -5°C	20 %	1,10	1,05	0,98	0,993
FROM -5°C TO -10°C	30 %	1,15	1,08	0,97	0,99
FROM -10°C TO -15°C	40 %	1,20	1,11	0,96	0,987

Example: 10 % glycol in EAC0091SKHN

Minimum flow:  $1,19 \text{ m}^3/\text{h} \times 1,02$

Pressure drop  $\times 1,07$

System capacity  $\times 0,99$

Also is advisable to use a heater on water exchange "auto-trace heater".

Do not take advise of these actions over exchangers, piping, devices etc., may damage the installation.

**Optionally**, an immersion heater can be supplied complete with safety thermostat and pressostat fitted in the buffer tank of the cooling only chiller. A similar option is available for heat pump versions with the added advantage of a supplementary heating source (hydronic version units).

11.-For cooler or heating pump units the hydraulic system component settings such as pump, buffer tank, expansion device, safety valve etc. must be calculated and entered.

12.-See pressure drop of the unit, and add to piping pressure drop, to obtain the total pressure drop of the system.

13.-When the measurements are correct install a pressure reducing valve to provide sufficient pressure for the water pump to compensate the loss of power.

## 2.- INSTALLATION

### 2.5.- ELECTRICAL CONNECTIONS



- BEFORE MAKING ANY ELECTRICAL CONNECTIONS, BE SURE THAT ALL CIRCUIT BREAKERS ARE OPEN.
- IN ORDER TO CARRY OUT THE ELECTRICAL CONNECTIONS, FOLLOW THE ELECTRICAL DIAGRAM SUPPLIED WITH THE UNIT.

POWER SUPPLY	230V SINGLE PHASE UNITS		230V THREE-PHASE UNITS		400V THREE-PHASE UNITS	
	 1N ~ 230V - 50 Hz + PE		 3 ~ 230V - 50 Hz + PE		 3N ~ 400V - 50 Hz + PE	
UNIT MODEL	NUMBER OF WIRES X SECTION					
	Without AEC	With AEC	Without AEC	With AEC	Without AEC	With AEC
0091S	3 x 4 mm <sup>2</sup>	3 x 4 mm <sup>2</sup>	4 x 4 mm <sup>2</sup>	4 x 6 mm <sup>2</sup>	5 x 2,5 mm <sup>2</sup>	5 x 4 mm <sup>2</sup>
0111S	---	---	4 x 4 mm <sup>2</sup>	4 x 6 mm <sup>2</sup>	5 x 2,5 mm <sup>2</sup>	5 x 4 mm <sup>2</sup>
0151S	---	---	4 x 6 mm <sup>2</sup>	4 x 10 mm <sup>2</sup>	5 x 4 mm <sup>2</sup>	5 x 4 mm <sup>2</sup>
0191S	---	---	4 x 10 mm <sup>2</sup>	4 x 10 mm <sup>2</sup>	5 x 4 mm <sup>2</sup>	5 x 4 mm <sup>2</sup>
0211S	---	---	4 x 10 mm <sup>2</sup>	4 x 10 mm <sup>2</sup>	5 x 4 mm <sup>2</sup>	5 x 4 mm <sup>2</sup>
0251S	---	---	4 x 10 mm <sup>2</sup>	4 x 10 mm <sup>2</sup>	5 x 4 mm <sup>2</sup>	5 x 6 mm <sup>2</sup>
0291S	---	---	4 x 10 mm <sup>2</sup>	4 x 16 mm <sup>2</sup>	5 x 6 mm <sup>2</sup>	5 x 10 mm <sup>2</sup>
0351S	---	---	4 x 16 mm <sup>2</sup>	4 x 25 mm <sup>2</sup>	5 x 10 mm <sup>2</sup>	5 x 10 mm <sup>2</sup>
0431S	---	---	4 x 16 mm <sup>2</sup>	4 x 25 mm <sup>2</sup>	5 x 10 mm <sup>2</sup>	5 x 10 mm <sup>2</sup>
0472S	---	---	4 x 25 mm <sup>2</sup>	4 x 35 mm <sup>2</sup>	5 x 10 mm <sup>2</sup>	5 x 16 mm <sup>2</sup>
0552S	---	---	4 x 25 mm <sup>2</sup>	4 x 35 mm <sup>2</sup>	5 x 16 mm <sup>2</sup>	5 x 16 mm <sup>2</sup>
0672S	---	---	4 x 35 mm <sup>2</sup>	4 x 50 mm <sup>2</sup>	5 x 16 mm <sup>2</sup>	5 x 25 mm <sup>2</sup>
0812S	---	---	4 x 50 mm <sup>2</sup>	4 x 50 mm <sup>2</sup>	5 x 16 mm <sup>2</sup>	5 x 25 mm <sup>2</sup>

- AEC: Auxiliary Electric Coil
- The sections have been calculated to a distance of 50m and a low supply of 10V.  
Do not start the unit if the drop is greater than this.
- The wiring and circuit breakers to be mounted in the installation must comply with the Regulations in force.
- Ground wires must be properly connected and have a greater length than the phase wires.

#### VOLTAGE OPERATION LIMITS

MODELS	VOLTAGE	LIMIT
009	1N~230V-50Hz	1N~198-264V-50Hz
009-011-015-019	3~230V-50Hz	3~180-242V-50Hz
	3N~400V-50Hz	3N~342-462V-50Hz
019-021-025-029-035-043-047-055-067-081	3~230V-50Hz	3~198-264V-50Hz
	3N~400V-50Hz	3N~342-462V-50Hz

A remote controller is offered as an option.

To install this optional remote controller proceeded as follow:

- Connect exactly as indicated in electrical diagram
- The wire should not exceed 50 m.

**The three cables for connection from the keypad to the power board must be kept separate from other cables, using an individual cable channel; and use shielded cables, with a cross-section of 1 mm<sup>2</sup>.**

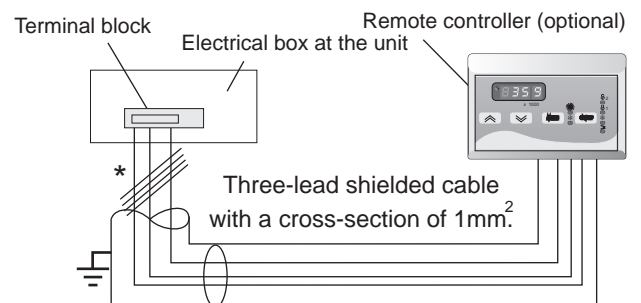

\*Connection to be made by installer  
MAXIMUM LENGTH 50m

---

## 3.- COMMISSIONING AND OPERATION

### 3.1.- STEPS TO FOLLOW FOR COMMISSIONING THE UNITS

#### PRE-START

Before commissioning the unit check the following:

- 1.- Check that the voltage is the same as the rated voltage on the specification plate.
  - 2.- Check that the supply to the control system is connected in accordance with the electrical diagram (if incorporates).
  - 3.- Check that the main switch is ON (if incorporates).
  - 4.- Make sure that the water connections are correct and have not been altered, as this can result in incorrect operation the flow divider will not operate if the connections are mixed.
  - 5.- Check that the fan can rotate freely.
  - 6.- Check the water pump's direction of rotation.
  - 7.- Check for air in the water system. Purge if necessary.
  - 8.- The compressor must not be started until the crankcase heater has been running for at least 8 hours.
- The compressor has a single phase electric heating element to assure a separation between the Refrigerant and the oil in the housing. This heater is activated when the compressor is off and stops working when the compressor is on.  
About eight hours before start up or after a long shutdown period, voltage should be supplied to the unit so that this heater will be activated.
  - Check that the compressor starts after two minutes.
  - Select cool or heat as the operating mode at the control unit.
  - When the compressor starts the fans rotate at maximum speed for a short time. They then rotate in accordance with the condensation temperature/pressure.



REMEMBER THAT THE COMPRESSOR IS A SCROLL TYPE COMPRESSOR:

**Before starting the unit, the compressor should be checked that rotates in the correct direction, through a three phase protection. Scroll type compressors only compress in one direction of the rotation. Single phase models are always started up in the proper direction; however, the three phase models, turn in either direction depending on the order of the power supply phases. Therefore, it is essential that the phase connection for scroll-type three-phase compressors be carried out correctly (the correct direction of rotation can be checked when the pressure on the suction side decreases and the pressure on the discharge side increases when the compressor is activated). If the connection is wrong, the rotation will be reversed causing a high noise level and a reduction in the amount of current consumed. If this occurs, the compressor's internal protection system will kick in shutting down the unit. The solution is to disconnect, switch the wires between two of the phases and connect the three again).**

- Occasionally, when compressor stops and starts, there is a metallic noise because of spirals of the compressor. This is normal.
- Check compressor oil level, sight glass included (on the sides of the compressor, the level should be between 1/4 and 3/4 in the sight glass, while during operation the level should be between 3/4 and full).
- Connect high and low pressure gauges and check that operating pressure values are normal.
- Measure electrical consumption for the unit and check that it is near what is indicated on the specification plate.
- Check the electrical consumption of the compressor and the fans with what is specified in the physical data sheets.
- In the case of a Heat Pump unit, make a cycle change on the Control Panel checking that the 4-way valve makes the change correctly. Check the pressure values in the new cycle.
- **Remember the low pressure switch is reset automatically and the high pressure switch is reset electronically.**
- **Remember that low pressure switch is automatic reset, if it has 3 cuts in one hour, it will be a manual reset, through the control of the unit.**

### 3.- COMMISSIONING AND OPERATION

#### 3.2.- CHECKING THE WATER FLOW RATE

It is very important that the unit operates at the correct water flow rate. It is dangerous to leave the unit operating at a low flow rate as this could result in serious damage to components as well as the water exchanger. If the unit operates at too high a flow rate, this will also hinder optimum performance. The best way of determining the operating flow rate is to measure the temperature difference between the inlet and outlet water.

##### Checking the water flow rate (it is vital to measure the thermal peak) (Standard unit)

For nominal and minimum water flow the difference between the inlet and outlet water temperature should be 5K (cooling and heating pump units in cooling cycle only) for an inlet temperature of 12°C, an outlet temperature of 7°C and an outside temperature of 35°C. If these conditions change, the unit capacity will also change and as a result for nominal flow the difference between the inlet and outlet water temperature will vary slightly from 5K as can be seen in the following table, based on nominal flow rate.

		$\Delta T$ ( inlet water temperature - outlet water temperature)						
		Outside temperature °C						
Water output °C		15	20	25	30	35	40	45
7		6,1	5,8	5,5	5,3	5,0	4,7	4,4
9		6,5	6,2	5,9	5,6	5,3	5,0	4,7
11		7,0	6,7	6,4	6,0	5,7	5,4	5,0

If the unit must be started in the heating cycle and if you wish to operate at nominal cooling rate, the following shows the approximate differences between the inlet and outlet water temperatures for the various conditions.

		$\Delta T$ ( inlet water temperature - outlet water temperature)				
		Outside temperature °C W.B.				
Water output °C		-6	0	6	12	18
35		4,5	5,5	6,5	7,5	8,5
50		4	5	6	7	8

**Note:** The unit control system displays the inlet and outlet water temperature to be displayed. See the Control Description section.

Check that the correct water pump has been selected, taking into account the loss of pressure in the hydraulic system. It is dangerous to let the unit run at a low rate and any faults which may result will not be covered under warranty.

Do not start up the air conditioning units or the fan coils until the water temperature reaches the set temperature or use an automatic control device which cancels the air conditioning unit operation if the installation is not properly set.

When everything is operating normally, take a reading of all the data and fill out the Commissioning Sheet.

### 3.- COMMISSIONING AND OPERATION

#### 3.3.- CORROSION RESISTANCE OF COPPER AND STAINLESS STEEL OF PLATES EXCHANGER (WATER EXCHANGER)

GUIDE TO MEASURE A ANALYSIS OF THE WATER IN THE CIRCUIT.

The resistance guide below is an attempt of give a picture of the corrosion resistance of the stainless steel of the type AISI 316 and pure copper in the water, to a number of important chemical factors. The actual corrosion is however a very complex process influenced by many factors in combination. This table is therefore a considerable simplification and should not be overvalued.

Explanations:

- + Good resistance under normal conditions
- 0 Corrosion problems can occur especially when the factors are valued as 0
- Use is not recommended

WATER CONTAINING	CONCENTRATION mg/l or ppm	AISI 316	COPPER
Alcanity (HCNO <sub>3</sub> )	<70	+	0
	70-300	+	+
	>300	+	0
Sulfate (SO <sub>4</sub> <sup>2-</sup> )	<70	+	+
	70-300	+	-
	>300	0	-
HCO <sub>3</sub> / SO <sub>4</sub> <sup>2-</sup>	>1.0	+	+
	<1.0	+	-
Electrical conductivity	<10 µS/cm	+	0
	10-500 µS/cm	+	+
	>500 µS/cm	+	0
pH	<6.0	0	0
	6.0-7.5	0/+	0
	7.5-9.0	+	+
	>9.0	+	0
Ammonium (NH <sub>3</sub> )	<2	+	+
	2-20	+	0
	>20	+	-
Chloroides(Cl <sup>-</sup> )	<300	+	+
	>300	0	0
Free chlorine (Cl <sub>2</sub> )	<1	+	+
	1-5	+	0
	>5	0/+	-
Hydrogen sulfide (H <sub>2</sub> S)	<0.05	+	+
	>0.05	+	-
Free (aggressive) Carbon Dioxide (CO <sub>2</sub> )	<5	+	+
	5-20	+	0
	>20	+	-
Total hardness (°dH)	4.0-8.5	+	+
Nitrate (NO <sub>3</sub> )	<100	+	+
	>100	+	0
Iron (Fe)	<0.2	+	+
	>0.2	+	0
Aluminum (Al)	<0.2	+	+
	>0.2	+	0
Manganese (Mn)	<0.1	+	+
	>0.1	+	0

---

## 4.- MAINTENANCE

### 4.1.- PREVENTIVE MAINTENANCE



#### PREVENTIVE MAINTENANCE PREVENTS COSTLY REPAIRS.

We recommend regular and thorough servicing of the LENNOX unit. It is therefore advisable to ask your dealer about maintenance contracts. Check maintenance of the following points (depending on the operating conditions maintenance every 6 months may be necessary).

#### - GENERAL STATE OF THE CASING:

Caseing, paint, deterioration due to bumps, rust spots, leveling and supporting, state of the antivibration mounts, if installed, screwed panels, etc.

#### - ELECTRICAL CONNECTIONS:

State of hoses, tightness of screws, grounding, current draw of the compressor and fans and checking that the unit is receiving the correct voltage.

#### - COOLING CIRCUIT:

Check that pressure values are correct and that there are no leaks. Check that there is no damage to the pipe insulation, that the state of the batteries is correct and that there are no chips or clogs retained by the air flow, etc.

#### - COMPRESSOR:

Inspect the oil level, if sight glass is present.  
Inspect the state of the compressor mountings.

#### - FANS:

Check that fans turn freely and in the correct direction without excessive noises.

#### - CONTROL:

Check Set Points and normal operation.

#### - WATER:

If the installation contains anti-freeze, regularly check the state of the anti-freeze as well as the cleanliness of the water.

#### - WATER FILTER:

Clean the inlet water filter if necessary.

#### - WATER PUMP:

When the installation is going to work with percentages of glycol up to 20% and water temperatures below -5°C, even do we use a specific closing for the water pump, it is advisable to clean the water pump's closing every year and a half, in order to avoid leaks by crystallization.

#### - PLATE EXCHANGER:

Prove the general isolation state and tightness of the water connections.



## 4.- MAINTENANCE

### 4.2.- CORRECTIVE MAINTENANCE



#### IMPORTANT

MAKE SURE THAT THE UNIT IS COMPLETELY DISCONNECTED FROM THE POWER SUPPLY WHEN CARRYING OUT ANY TYPE OF WORK ON THE MACHINE

If some component in the cooling circuit must be replaced, follow these recommendations:

- Always use original replacement parts.
- Remove the entire refrigerant charge from the unit from through the schrader valves. Create a slight vacuum as a safety measure.
- Regulation prohibits the release on the refrigerant into the atmosphere.
- If cuts must be made in the pipe work, use pipe cutters. Do not use saws or any other tools that produce filings.
- All brazing must be carried out in a nitrogen atmosphere to prevent corrosion from forming.
- Use silver alloy brazing rod.
- Take special care that the flame from the torch is aimed in the opposite direction from the component to be welded and is covered with a wet rag in order to avoid overheating.

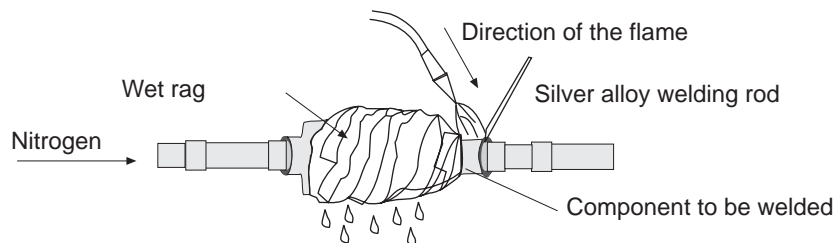

- Take very special care if 4-way check valves are to be replaced since these have internal components that are very heat-sensitive such as plastic, teflon, etc.
- If a compressor must be replaced, disconnect it electrically and un-braze the suction and discharge lines. Remove the securing screws and replace the old compressor with the new one. Check that the new compressor has the correct oil charge, screw it to the base and connect the lines and electrical connections.
- Carry out the vacuum above and below through the schrader valves of the outdoor unit until -750 mm Hg is reached. Once this level of vacuum has been reached, keep the pump in operation for at least one hour. **DO NOT USE THE COMPRESSOR AS A VACUUM PUMP.**
- Charge the unit with refrigerant according to the data on the Rating Plate for the unit and **check that there are no leaks.**



#### PRECAUTIONS TO BE TAKEN IN THE USE OF R-407C Refrigerant

If R-407C Refrigerant is used in the unit, the following precautions characteristic of this gas should be taken:

- The Vacuum Pump must have a Check Valve or Solenoid Valve.
- Pressure Gauges and Hoses for the exclusive use with R-407C Refrigerant should be used.
- The charge should be carried out in the Liquid Phase.
- Always use scales to weight-in charge
- Use the Leak Detector exclusive for R-407C Refrigerant.
- Do not use mineral oil, only synthetic oil to ream, expand or make connections.
- Keep pipes capped before using them and be very thorough about any possible dirt (dust, filings, burrs, etc.).
- When there is a leak, gather what is left of the charge, create a vacuum in the unit and completely recharge with new R-407C Refrigerant.
- Brazing should always be carried out in a nitrogen atmosphere.
- Reamers should always be well sharpened.
- The refrigerant bottle must contain at least 10 % of the total amount .

## 4.- MAINTENANCE

### 4.3.- FAILURE DIAGNOSIS

PROBLEM	CAUSE	ACTION
The unit does not start after the last start.	<ul style="list-style-type: none"> <li>* Disconnected supply.</li> <li>* Main switch set to STOP.</li> <li>* No water flow.</li> <li>* Fuses are broken.</li> <li>* Low electrical supply.</li> <li>* One of the safety devices has been activated.</li> <li>* Compressor fault.</li> <li>* Low water temperature.</li> </ul>	<ul style="list-style-type: none"> <li>* Check electrical supply.</li> <li>* Connect main switch.</li> <li>* Start water pump (and check air in system).</li> <li>* Check voltage.</li> <li>* Check antifreeze thermostat.</li> <li>* Check high/low pressure switch.</li> <li>* Change compressor.</li> <li>* Create demand for cooling.</li> </ul>
The fan does not work (although the compressor is operating).	<ul style="list-style-type: none"> <li>* Internal safety device open.</li> <li>* Bad connection.</li> <li>* Poor condensation control.</li> </ul>	<ul style="list-style-type: none"> <li>* Let the motor cool.</li> <li>* Connect properly.</li> <li>* Check operation.</li> </ul>
The compressor stops when the high pressure switch is cut off.	<ul style="list-style-type: none"> <li>* Battery blocked.</li> <li>* Unit operating outside of limiting.</li> <li>* Abnormal operation of the fans.</li> </ul>	<ul style="list-style-type: none"> <li>* Maintain battery.</li> <li>* Check the ventilators.</li> </ul>
The compressor stops when the low pressure switch is cut off.	<ul style="list-style-type: none"> <li>* Insufficient R-22 charge.</li> <li>* The water exchanger is blocked (water side).</li> <li>* No water flow.</li> </ul>	<ul style="list-style-type: none"> <li>* Check the R-22 charge.</li> <li>* Maintain the exchanger.</li> <li>* Check that there is sufficient water flow.</li> </ul>
The oil level in the compressor is very low.	<ul style="list-style-type: none"> <li>* The cabinet heater is not working.</li> </ul>	<ul style="list-style-type: none"> <li>* Replace the cabinet heater and fill up with oil.</li> </ul>
High noise level of compressor and high and low pressures are abnormal.	<ul style="list-style-type: none"> <li>* Phase connection for compressor power supply incorrectly.</li> </ul>	<ul style="list-style-type: none"> <li>* Switch the wires between two of the phases of compressor power supply.</li> </ul>



<b>BELGIUM, LUXEMBOURG :</b>	LENNOX BENELUX N.V./S.A. tel. : + 32 3 633 30 45 fax : + 32 3 633 00 89 e-mail : info.be@lennoxbenelux.com
<b>CZECH REPUBLIC :</b>	JANKA LENNOX a.s. tel. : + 420 2 510 88 111 fax : + 420 2 579 10 393 e-mail : janka@janka.cz
<b>FRANCE :</b>	LENNOX FRANCE tel. : + 33 1 64 76 23 23 fax : + 33 1 64 76 35 75 e-mail : marketing.france@lennoxfrance.com
<b>GERMANY :</b>	LENNOX DEUTSCHLAND GmbH tel. : + 49 69 42 09790 fax : + 49 69 42 09 79 40 e-mail : info.de@lennoxdeutschland.com
<b>NETHERLANDS :</b>	LENNOX BENELUX B.V. tel. : + 31 33 2471 800 fax : + 31 33 2459 220 e-mail : info@lennoxbenelux.com
<b>POLAND :</b>	LENNOX POLSKA Sp. z o.o. tel. : + 48 22 832 26 61 fax : + 48 22 832 26 62 e-mail : info@lennoxpolska.pl
<b>PORTUGAL :</b>	LENNOX PORTUGAL LDA. tel. : +351 22 998 33 70 fax : +351 22 998 33 79 e-mail : info@lennoxportugal.com
<b>RUSSIA :</b>	LENNOX DISTRIBUTION MOSCOW tel. : + 7 095 246 07 46 fax : + 7 502 933 29 55 e-mail : lennox.dist.moscow@netmaster.ru
<b>SLOVAKIA :</b>	LENNOX SLOVENSKO s.r.o. tel. : + 421 2 44 87 19 27 fax : + 421 2 44 88 64 72 e-mail : lennox.slovensko@lennox.sk
<b>SPAIN :</b>	LENNOX REFAC S.A. tel. : + 34 915 40 18 10 fax : + 34 915 42 84 04 e-mail : marketing@lennox-refac.com
<b>UKRAINE :</b>	LENNOX DISTRIBUTION KIEV tel. : + 380 44 213 14 21 fax : + 380 44 213 14 21 e-mail : jankauk@uct.kiev.ua
<b>UNITED KINGDOM, IRELAND :</b>	LENNOX INDUSTRIES LTD tél. : + 44 1604 599400 fax : + 44 1604 594200 e-mail : ukmarketing@lennoxind.com
<b>OTHER EUROPEAN COUNTRIES, AFRICA, MIDDLE-EAST :</b>	LENNOX DISTRIBUTION tel. : + 33 4 72 23 20 14 fax : + 33 4 72 23 20 28 e-mail : marketing@lennoxdist.com



**LENNOX**<sup>®</sup>

[www.lennox europe.com](http://www.lennox europe.com)

**ECOLEAN IOM**  
**Cod : MIL76E-0703**

Due to Lennox's ongoing commitment to quality, Specifications, Ratings and Dimensions subject to change without notice and without incurring liability. Improper installation, adjustment, alteration, service or maintenance can cause property damage or personal injury. Installation and service must be performed by a qualified installer and servicing agency.