

In the ecolean units ,we supply the following antivibration mounts as option

In models EAC/EAR from 009 to 043 we supply 4 avm`s code 43202350 (60 SHORE)

In models EAC/EAR from 0472 to 0812 we supply 6 avm`s code 43202351 (75 SHORE)



DIMENSIONS

A	90 mm
B	40 mm
C	10 mm
D	20 mm
E	53 mm
F	110 mm
G	137 mm

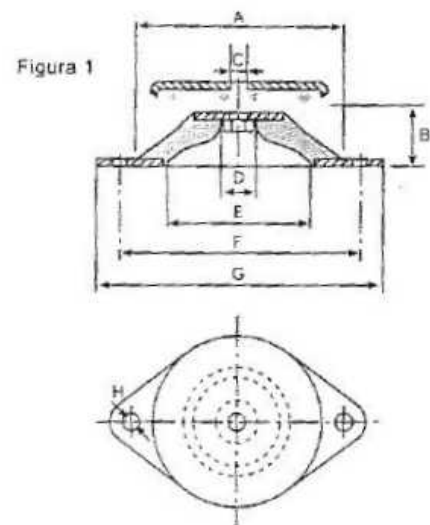

CALCULATION OF AVM'S DEFLECTION

B60 : Each avm support 160 kg with a deflection of 4 mm (43202350)

C75 : Each avm support 220 kg with a deflection of 4 mm (code 43202351)

