

*DOSSIER ELECTRIQUE  
ELECTRICAL FILE*



WA 370D K LN

Name / Name

Date: / Date  
19/10/2006

SE134642

1/  
21

CARACTERISTIQUES MACHINE			
MACHINE CHARACTERISTICS			
400 V	Pmax (kW)	Imax (A)	Idem (A)
	180.00	294.00	520.00
3.50Hz			

**CARACTERISTIQUES MOTEURS  
MOTOR CHARACTERISTICS**

REPERE MARKER	DESIGNATION	DESIGNATION	REFERENCE REFERENCE	Pabs. (kW)	Inom. (A)
M1	Compresseur	Compressor motor	ZR310	28.68	46.61
M2	Compresseur	Compressor motor	ZR310	28.68	46.61
M3	Compresseur	Compressor motor	ZR310	28.68	46.61
M4	Compresseur	Compressor motor	ZR310	28.68	46.61
M5	Compresseur	Compressor motor	ZR310	28.68	46.61
M6	Compresseur	Compressor motor	ZR310	28.68	46.61
M31	Ventilateur	Fan motor	ZA_900	0.98	1.75
M32	Ventilateur	Fan motor	ZA_900	0.98	1.75
M33	Ventilateur	Fan motor	ZA_900	0.98	1.75
M34	Ventilateur	Fan motor	ZA_900	0.98	1.75
M35	Ventilateur	Fan motor	ZA_900	0.98	1.75
M36	Ventilateur	Fan motor	ZA_900	0.98	1.75

NOMENCLATURE ARMOIRE ELECTRIQUE  
ELECTRIC PANEL ASSEMBLY BILL OF MATERIAL

REPERE MARKER	DESIGNATION	DESIGNATION	FOURNISSEUR SUPPLIER	REFERENCE REFERENCE
AP1	Carte interface circuit 1	Interface board circuit1	INF-03	
AP2	Carte interface circuit 2	Interface board circuit 2	INF-04	
Dép1	Alimentation peigne	Supply cable assembly	GV1G09	
Dép2	Peigne 1	Cable assembly 1	GV2G445	
KM1	Contacteur compresseur M1	Compressor contactor M1	LC1D40B7	
KM2	Contacteur compresseur M2	Compressor contactor M2	LC1D40B7	
KM3	Contacteur compresseur M3	Compressor contactor M3	LC1D40B7	
KM32	Contacteur ventilateur M32	Fan contactor M32	GV2ME07K1B7	
KM33	Contacteur ventilateur M33	Fan contactor M33	GV2ME07K1B7	
KM35	Contacteur ventilateur M35	Fan contactor M35	GV2ME07K1B7	
KM36	Contacteur ventilateur M36	Fan contactor M36	GV2ME07K1B7	
KM4	Contacteur compresseur M4	Compressor contactor M4	LC1D40B7	
KM5	Contacteur compresseur M5	Compressor contactor M5	LC1D40B7	
KM6	Contacteur compresseur M6	Compressor contactor M6	LC1D40B7	
QF1	Disjoncteur compresseur M1	Compressor circuit breaker M1	GV3ME63	
QF2	Disjoncteur compresseur M2	Compressor circuit breaker M2	GV3ME63	
QF3	Disjoncteur compresseur M3	Compressor circuit breaker M3	GV3ME63	
QF31	Disjoncteur ventilateur M31	Fan circuit breaker M31	GV2ME073	
QF34	Disjoncteur ventilateur M34	Fan circuit breaker M34	GV2ME073	
QF4	Disjoncteur compresseur M4	Compressor circuit breaker M4	GV3ME63	
QF5	Disjoncteur compresseur M5	Compressor circuit breaker M5	GV3ME63	
QF6	Disjoncteur compresseur M6	Compressor circuit breaker M6	GV3ME63	
QF70	Disjoncteur primaire TC1	Primary circuit breaker TC1	GB2DB08	
QF72	Disjoncteur secondaire TC1	Secondary circuit breaker TC1	GB2CD16	
QF73	Disjoncteur secondaire TC1	Secondary circuit breaker TC1	GB2CD16	
QF74	Disjoncteur départ résistances	Fan circuit breaker M38	GV2ME083	
QSG	Interrupteur INS 320A - 3P	Interrupteur INS 320A - 3P AN	31108	
QSG	Répartiteur	Terminal block	REP400A	
QSG	Cde frontale prolongée	Front operated isolator	31052	
QSG	Cache bornes	Terminal block cover	32565	
TC1	Transformateur contrôle	Transformer 24V	ABL6TTS63B	

SCHEMA ELECTRIQUE

0	1	2	3	4	5	6	7	8	9
EH1-->9	Résistance carter Crankcase heater		R	Résistances triphasée 3 phase heater		SP111-->115	Pressostat HP BP combiné HP LP combined switch		
EH11-->15	Résistance bouteille Receiver heater		RC	Circuits RC RC circuit		ST11-->15	Thermostat de commande résistances bouteille Receiver control thermostat		
EH16-->25	Résistance évaporateur Evaporator heater		RT	Sondes ou Capteurs Temperature or pressure sensor		ST16-->25	Thermostat de commande résistances évaporateur Evaporator resistance control thermostat		
EH26-->35	Résistance condenseur Condenser heater		RTTEA	Température d'entrée d'air Air inlet temperature		ST126-->30	Thermostat de commande résistances condenseur Condenser resistance control thermostat		
EH90-->100	Résistances diverses Various heaters		RTTEEG	Température d'entrée d'eau glacée Water inlet temperature		ST56-->65	Thermostat de surchauffe Overheat thermostat		
EH101	Résistance armoire Electrical panel heater		RTTEEG	Température de sortie d'eau glacée Water outlet temperature		ST166-->70	Thermostat de commande ventilateur armoire Electrical panel fan control thermostat		
FR91-->99	Protection moteur compresseur Solid state motor protection		RTTREF	Température de refoulement Discharge temperature		ST71-->75	Thermostat de dégivrage Defrost thermostat		
FU90	Fusibles divers Various fuses		RTTASP	Température d'aspiration Suction temperature		ST76-->85	Thermostat antiigel Antifreeze thermostat		
HA	Signalisation sonore Sound signal		RTTBP	Température d'évaporation Evaporating temperature		ST90-->100	Thermostat divers Various thermostats		
HL01	Voyant défaut général General fault light		SA90.	Interrupteurs divers Various switches		V	Diode Diode		
HL1-->9	Voyant marche compresseur Compressor operating light		SB90.	Boutons poussoirs divers Various push buttons		V0PT	Optocoupleur Optoelectronic coupler		
HL11-->20	Voyant marche ventilateur Fan running light signal		SD1	Contrôleur de débit Flow switch		XB	Barrette sectionnable Isolator link		
HL25-->29	Voyant défaut pompe Pump fault light signal		SL1-->5	Contrôleur de niveau d'eau Water Level controller		XS90	Prise de courant plug		
HL30	Voyant sous tension Voltage ON light signal		SL16-->20	Contrôleur de niveau d'huile Oil level controller		YP1-->5	Détendeur électronique Electronic expansion valve		
HL31-->39	Voyant arrêt contrôle Control shutdown light signal		SP1-->9	Pressostat HP sécurité HP pressure switch		YV1-->5	Electrovanne liquide liquid line solenoid valve		
HL41-->49	Voyant arrêt sécurité Safety shutdown light signal		SP11-->15	Pressostat BP sécurité BP pressure switch		YV6-->15	Electrovanne réduction de puissance compresseur Compressor capacity reduction solenoid valve		
HL51-->60	Voyant défaut ventilateur Fan shutdown light signal		SP16-->25	Pressostat d'huile Oil pressure switch		YV16-->20	Electrovanne injection de liquide Liquid injection solenoid valve		
HL65-->69	Voyant marche pompe Pump operation light		SP26-->30	Pressostat BP antiigel Antifreeze LP pressure switch		YV21-->25	Electrovanne économiseur Economizer solenoid valve		
HL90	Voyant divers Various light signal		SP31-->50	Pressostat HP de commande ventilateur Fan control HP pressure switch		YV26-->35	Electrovanne by-pass compresseur Compressor by-pass solenoid valve		
KA50-->75	Relais divers Various relays		SP51-->55	Pressostat HP de commande résistance bouteille Receiver heater HP pressure switch		YV36-->40	Electrovanne gaz chauds pressostatique Pressure control hot gas solenoid valve		
KM90	Contacteurs divers Various contactors		SP56-->60	Pressostat HP de commande vanne décharge bouteille Discharge valve HP pressure switch		YV41-->45	Electrovanne gaz chauds thermostatique Thermostatic hot gas solenoid valve		
KT90	Relais temporisés divers Various time delayed relays		SP61-->65	Pressostat HP de commande de délestage Overload control HP pressure switch		YV61-->70	Electrovanne inversion de cycle 4 way reversing solenoid valve		
M111	Ventilateur de culasse compresseur Compressor cylinder head fan		SP71-->75	Pressostat de commande by-pass détenteur Expansion valve by-pass control pressure switch		YV71-->75	Electrovanne by-pass détenteur Thermostatic expansion valve by-pass solenoid valve		
P1	Afficheur Display		SP90-->110	Pressostats divers Various pressure switch		YV90	Electrovanne diverses Various solenoid valves		

SE134642

## SCHEMA ELECTRIQUE



0 1 2 3 4 5 6 7 8 9

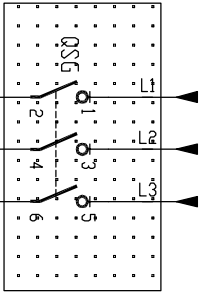

OPTIDN  
 INTERUPTEUR GENERAL  
 MAINS SWITCH  
 OPTIDN

L11  
 L12  
 L13

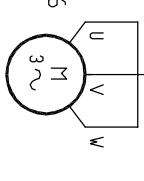
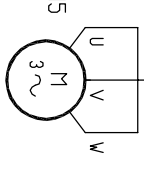
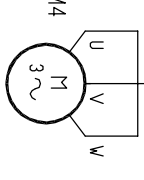
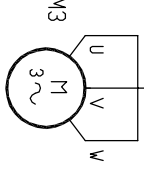
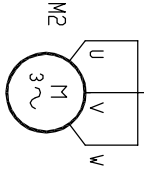
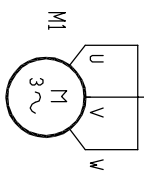
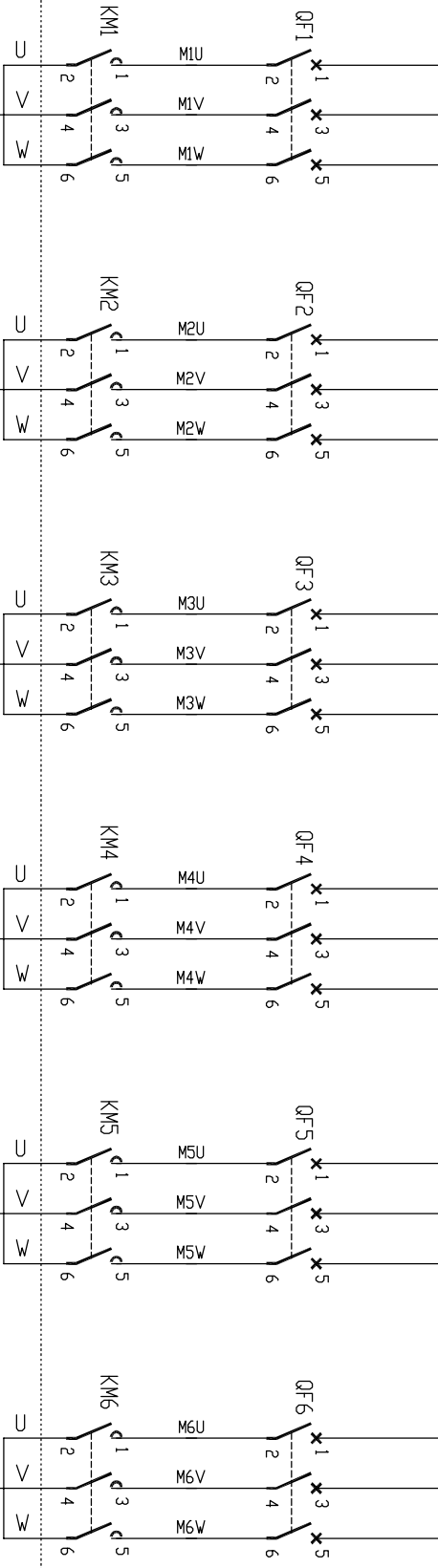

SCHEMA ELECTRIQUE

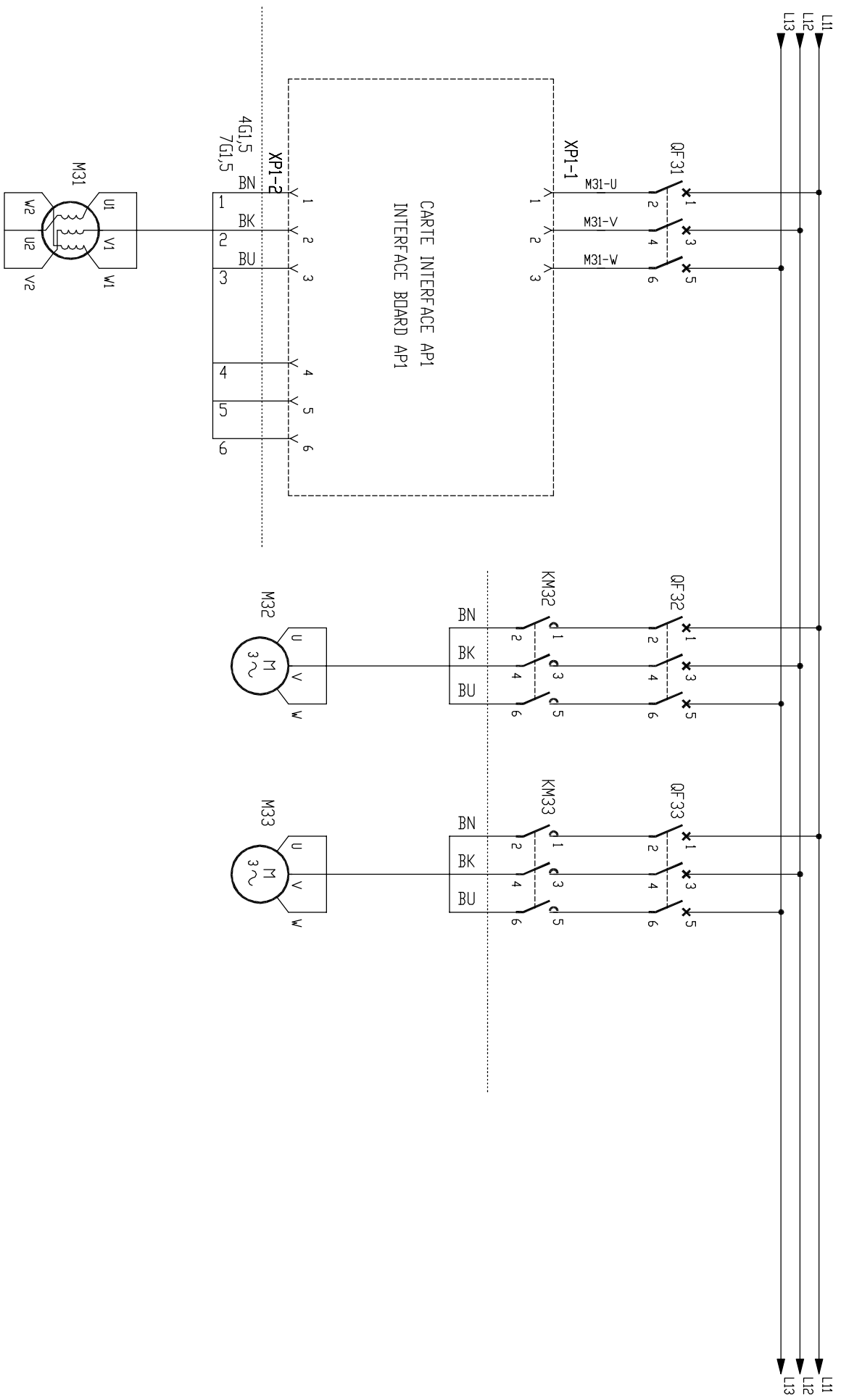

**SCHEMA ELECTRIQUE**

0 1 2 3 4 5 6 7 8 9

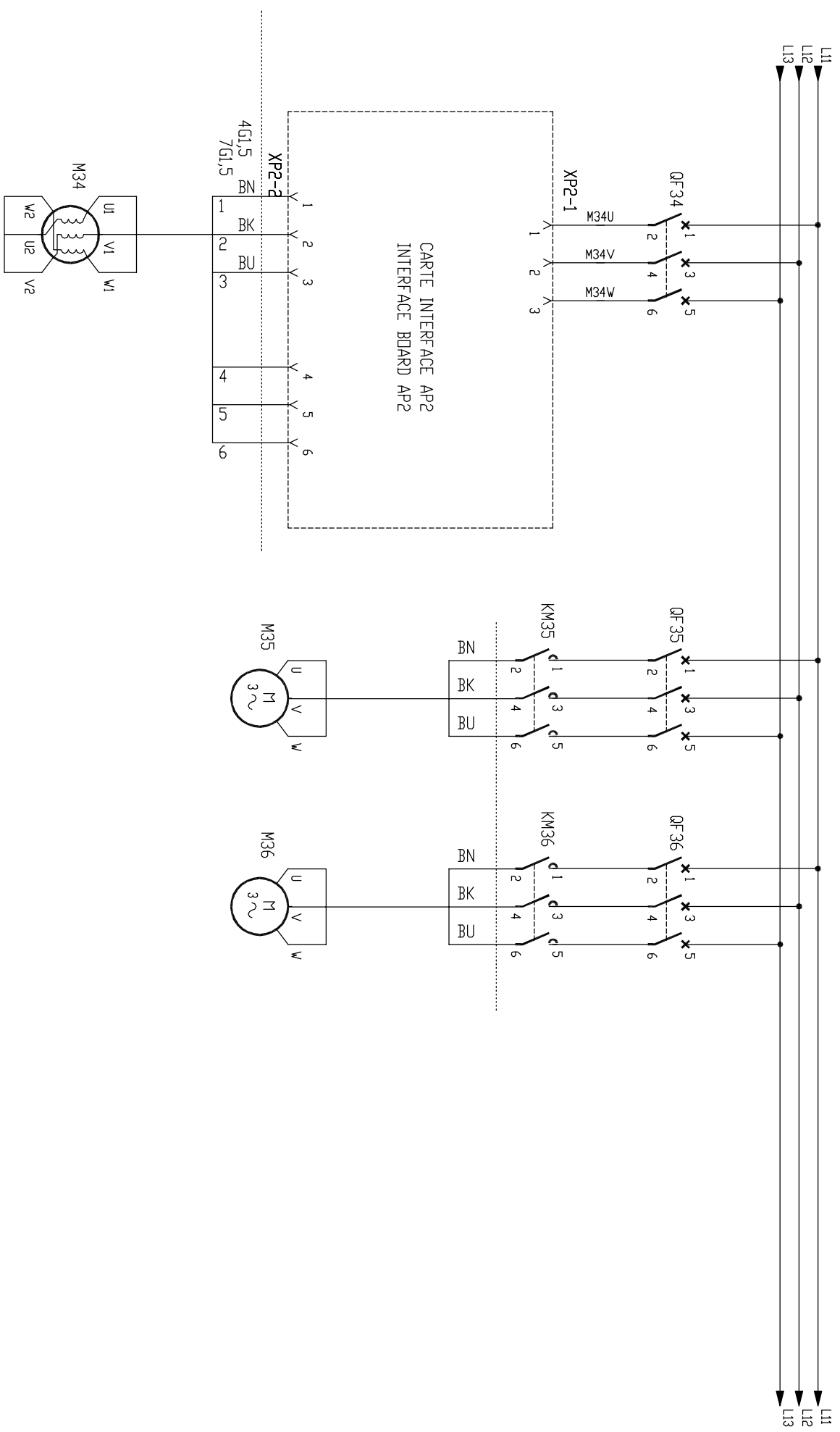

SCHEMA ELECTRIQUE



IF: SOFT STARTER OPTION LH4: KM1 --> KA11  
 SI: DEM. ELFC. OPTION LH4: KM2 --> KA12  
 KM3 --> KA13  
 KM4 --> KA14  
 KM5 --> KA15  
 KM6 --> KA16

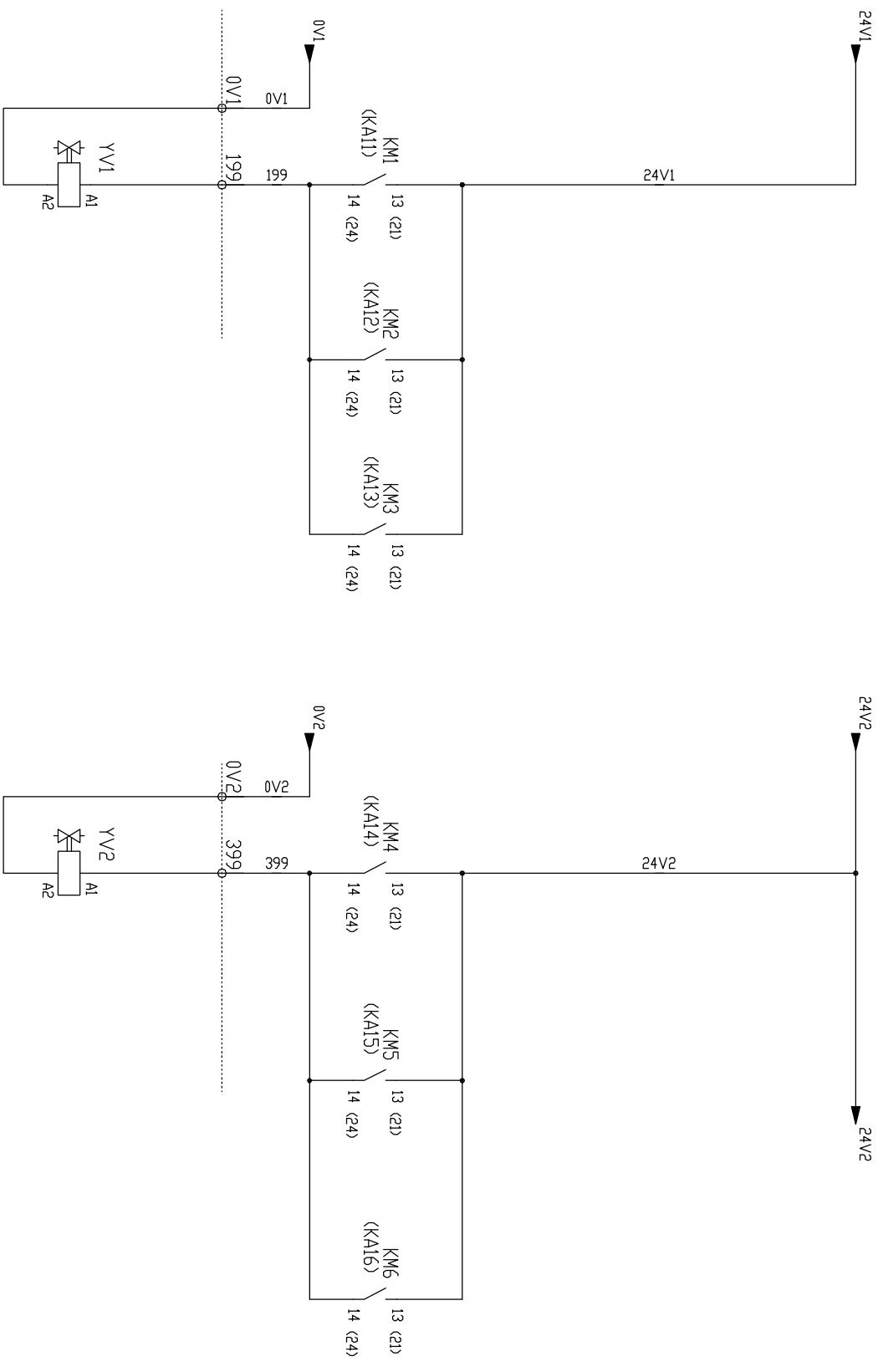

SCHEMA ELECTRIQUE

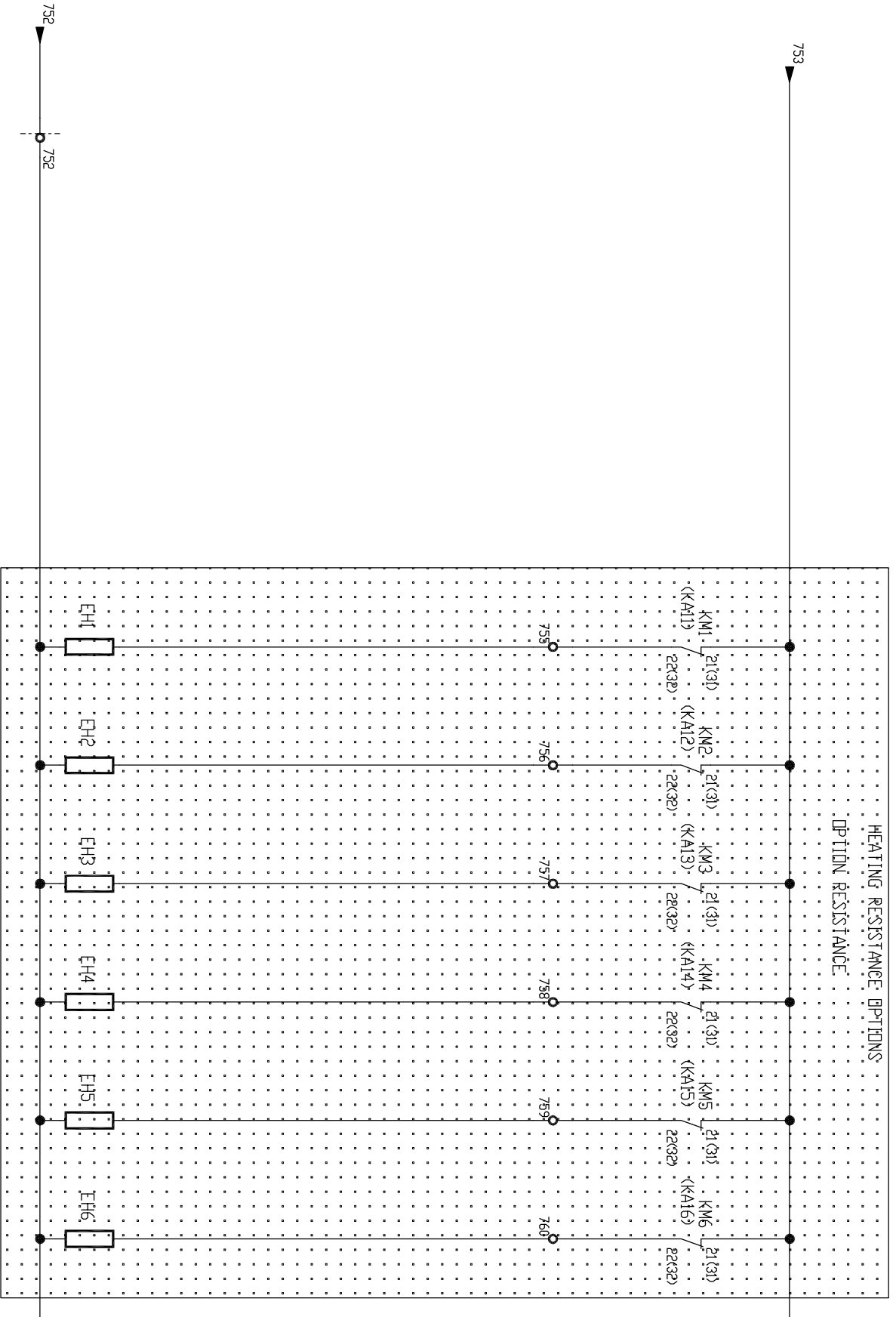

TF: SOFT STARTER OPTION LH4: KM1 → KA11  
 SI: DEM. ELEC. OPTION LH4: KM2 → KA12  
 KM3 → KA13  
 KM4 → KA14  
 KM5 → KA15  
 KM6 → KA16

# SCHEMA ELECTRIQUE

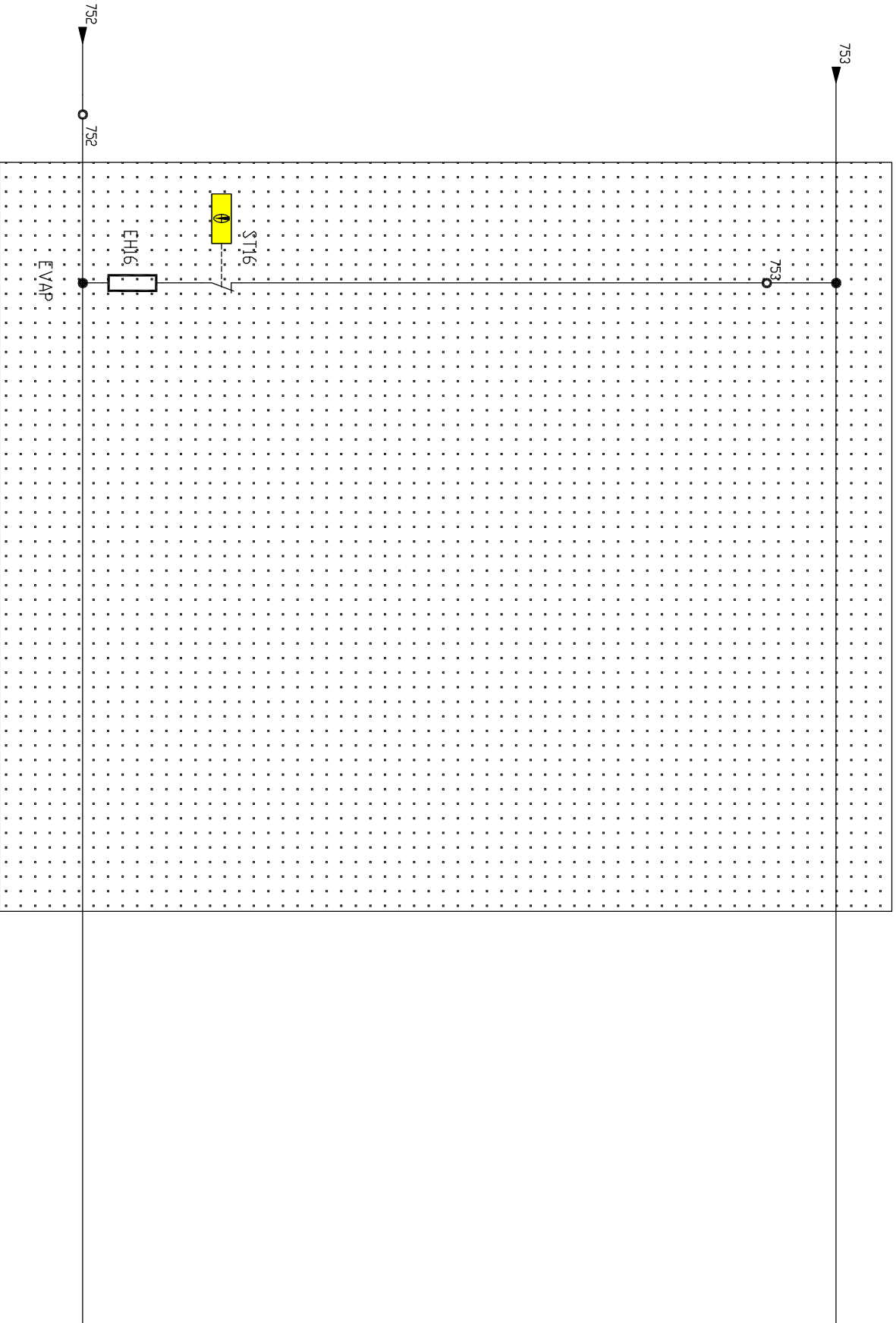

**SCHEMA ELECTRIQUE**

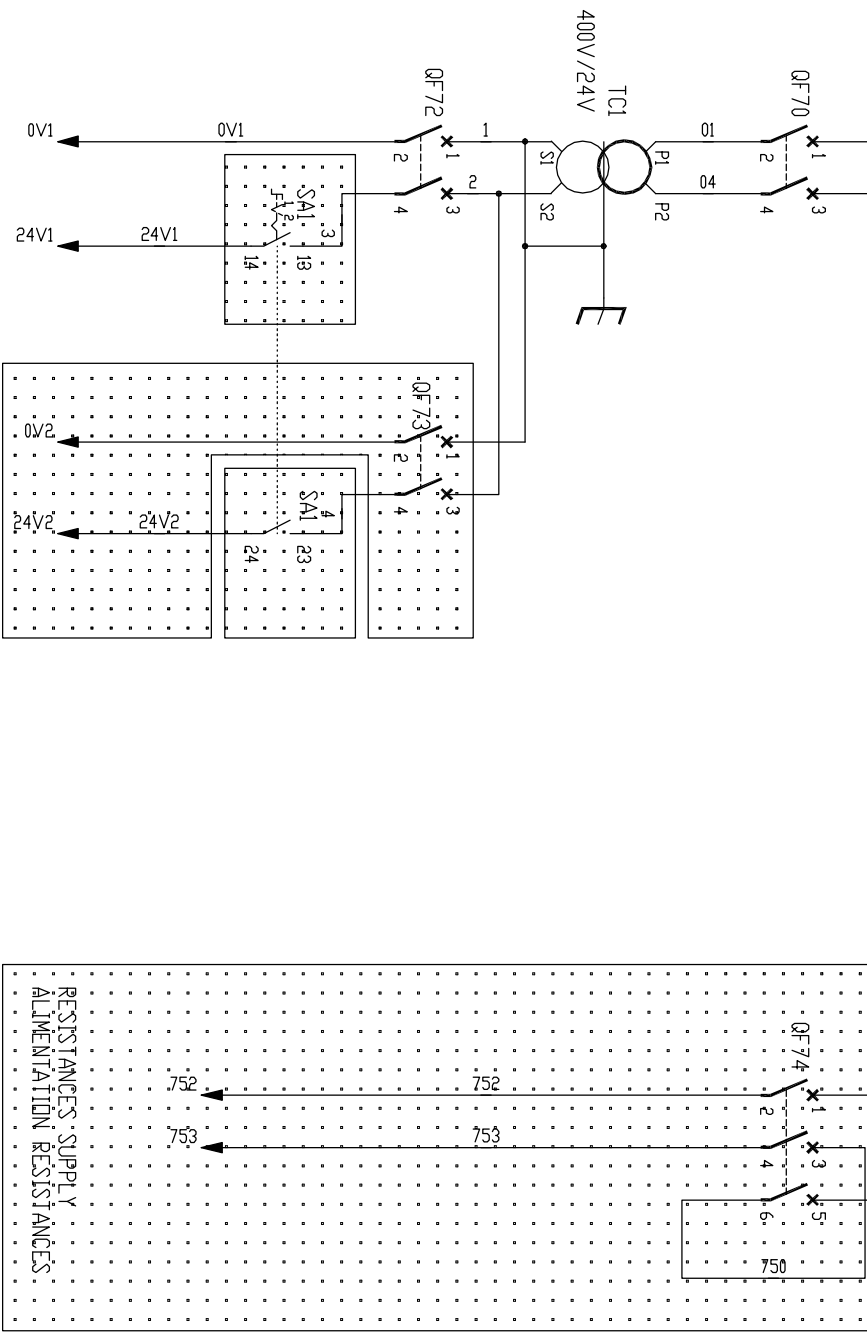
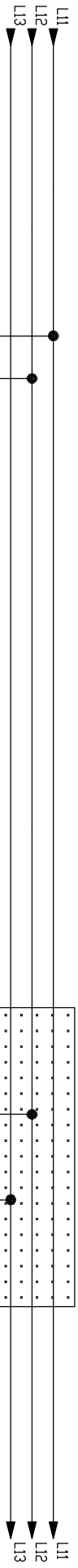

IF ND OPTIION  
 MAINS SWITCH  
 SAI DOOR MOUNTED  
 SI PAS OPTIION  
 INTERRUPTEUR AG  
 SAI SUR PORTE

SI POWER  
 TRANSFD >250 VA  
 SI PUISSANCE  
 TRANSFD >250 VA

CONTROL POWER SUPPLY  
 ALIMENTATION CONTROL

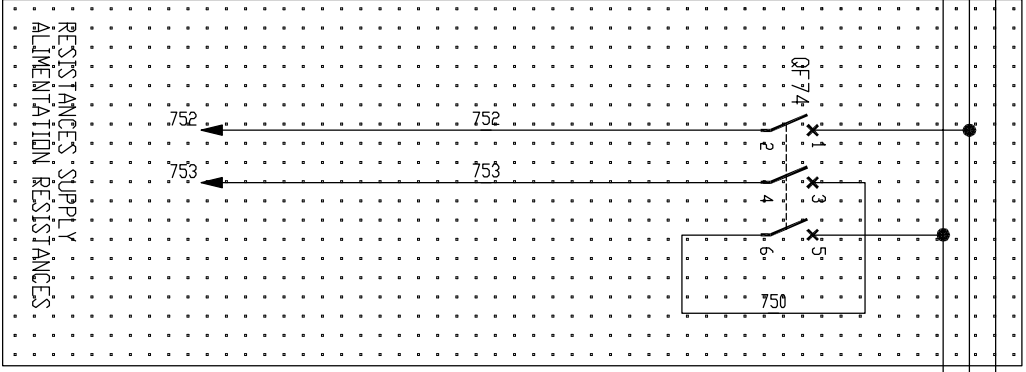

# SCHEMA ELECTRIQUE

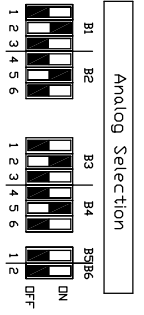
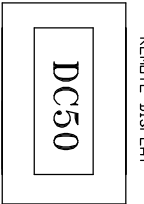
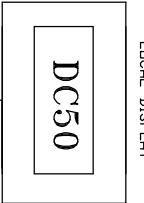
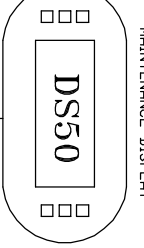
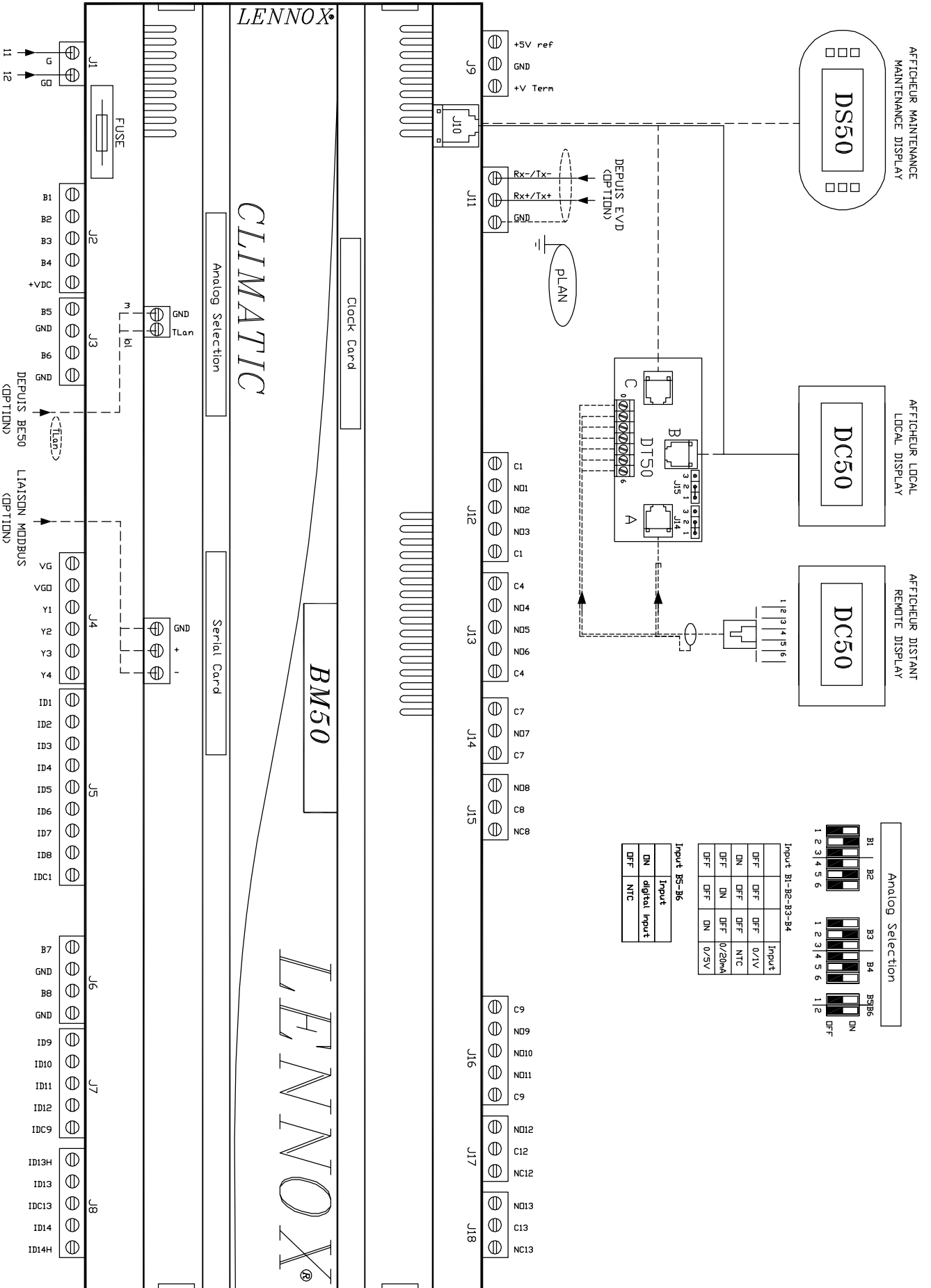

Input	B1-B2-B3-B4	Input
OFF	OFF	0/1V
ON	OFF	NTC
OFF	ON	0/20mA
OFF	OFF	0/5V

Input	B5-B6	Input
ON	digital input	
OFF	NTC	

SCHEMA ELECTRIQUE

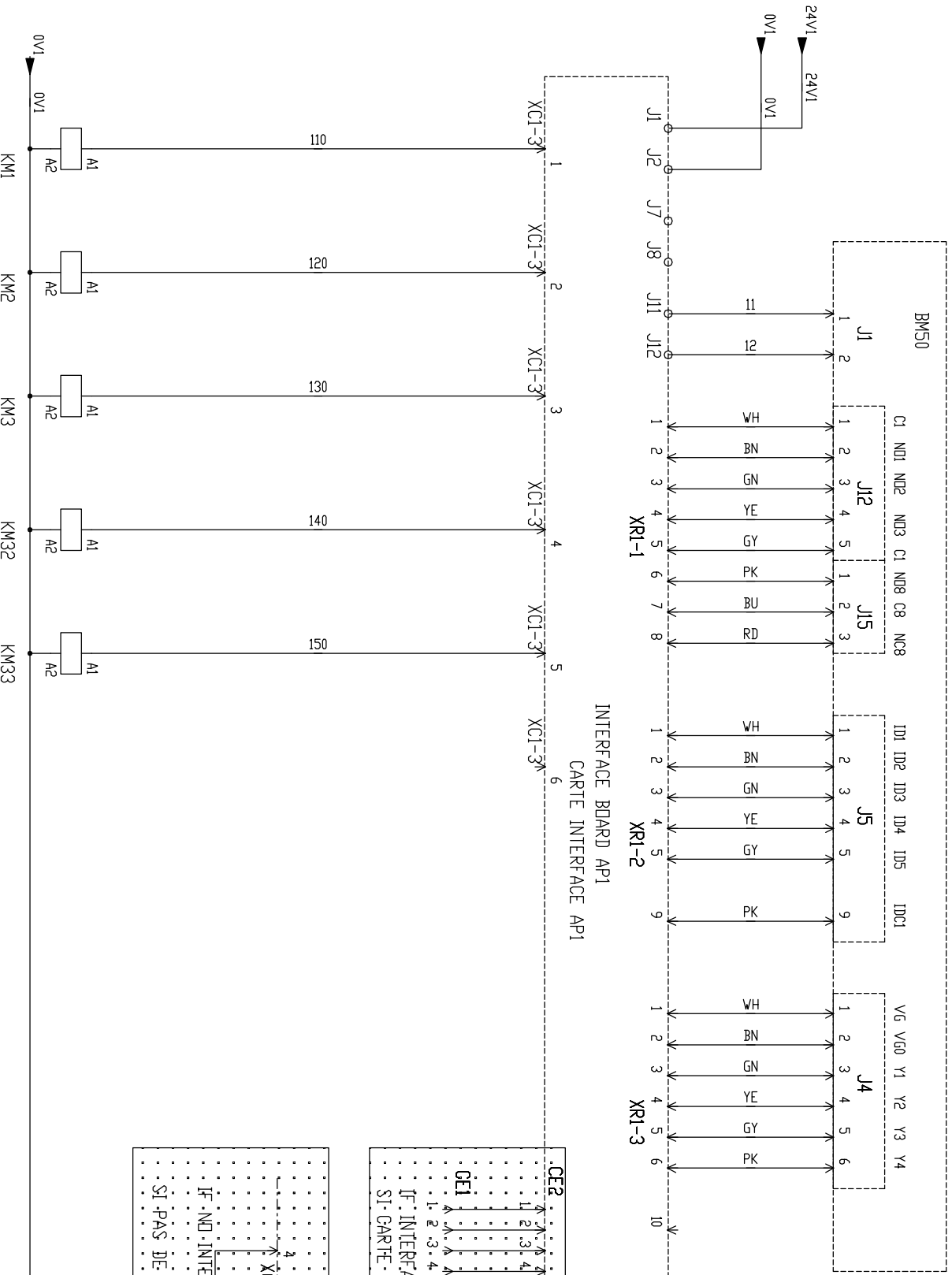

IF: SOFT-STARTER OPTIION LHM4 KM1 --> KA11  
 SI: option démarreur LHM4 : KM2 --> KA12  
 KM3 --> KA13  
 KM32  
 KM33

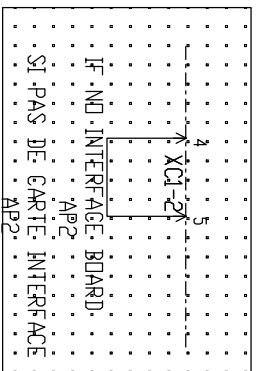
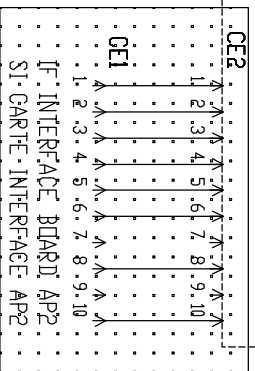
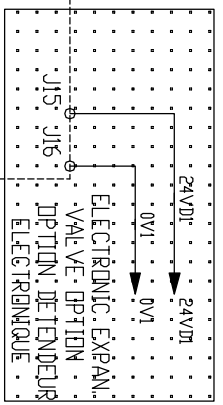

SCHEMA ELECTRIQUE

-IF SOFTSTARTER OPTION LHM4 KM4 -> KA14 . . . . . KM6 -> KA15 . . . . .  
 Si option démarreur LH4 : KM5 -> KA15 . . . . .

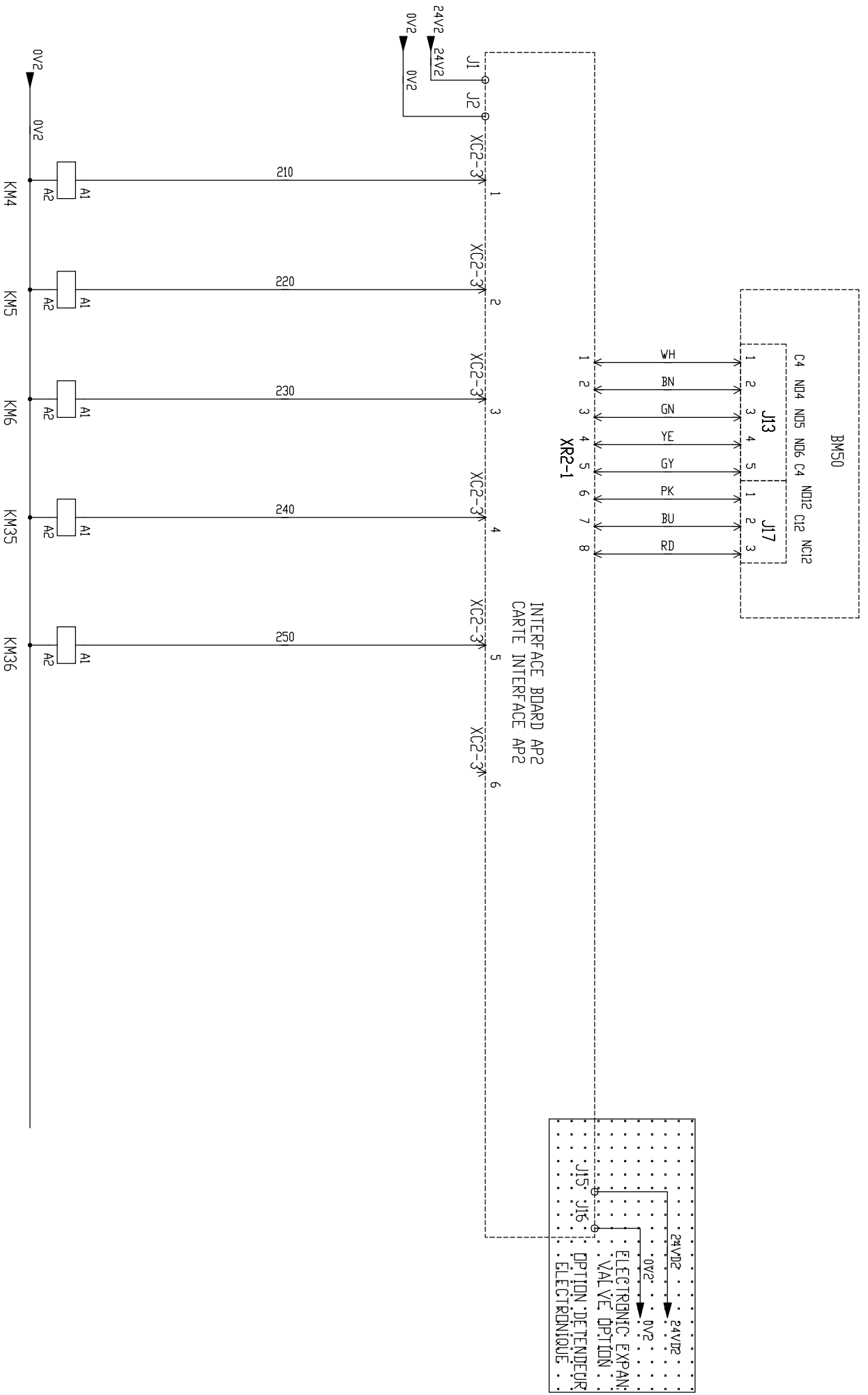

INTERFACE BOARD AP2  
 CARTE INTERFACE AP2

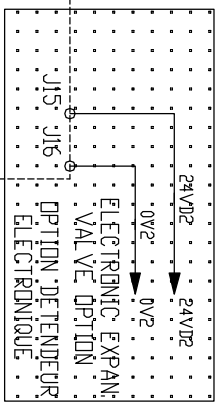

# SCHEMA ELECTRIQUE

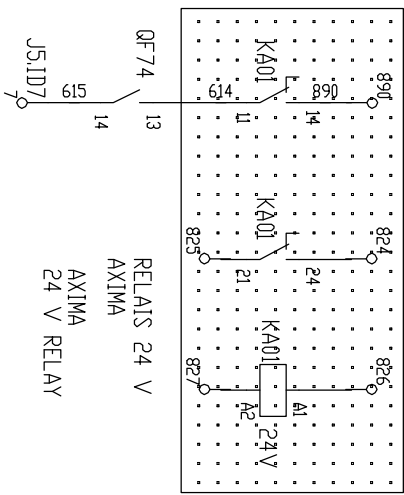
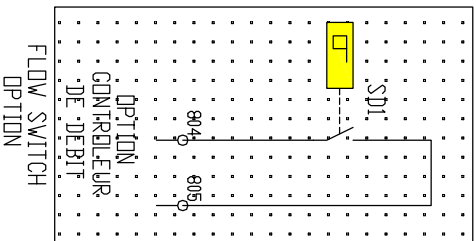
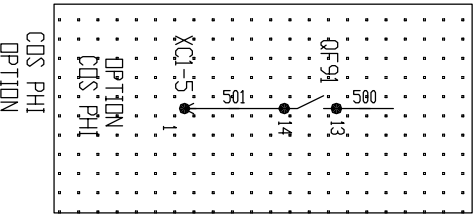
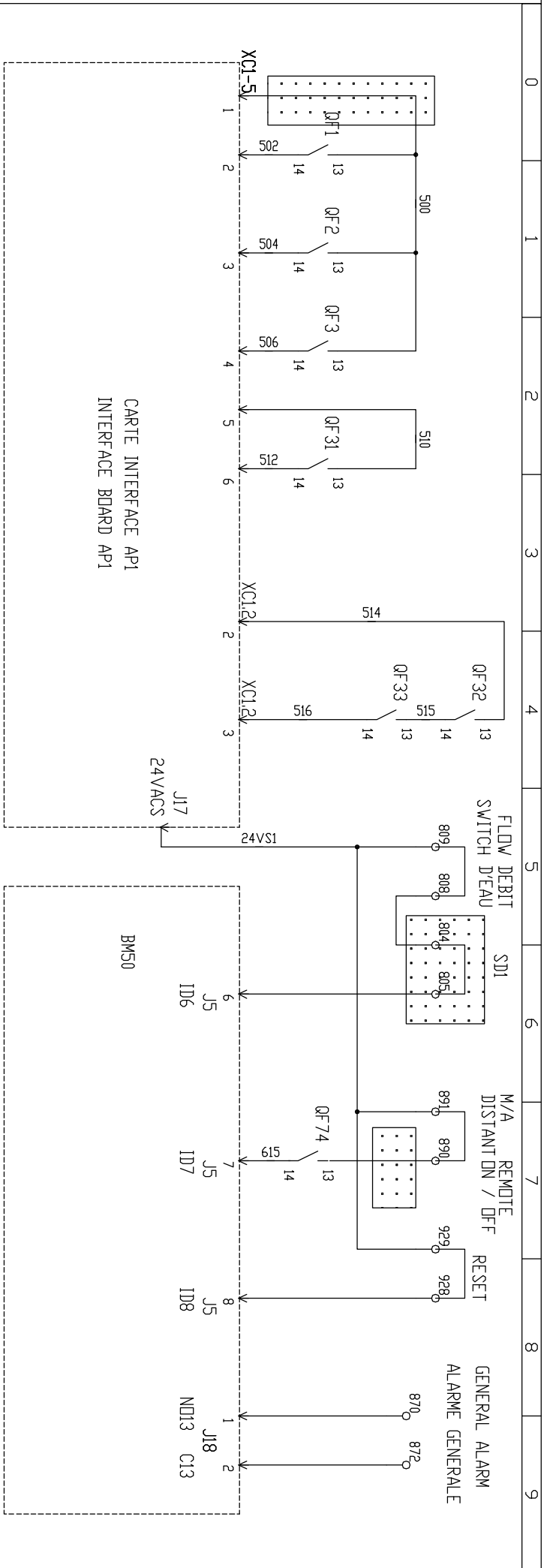

# SCHEMA ELECTRIQUE



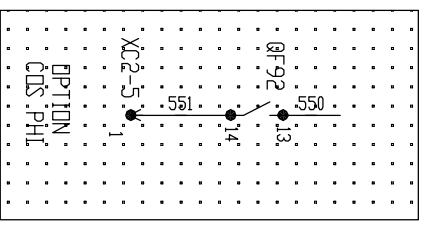
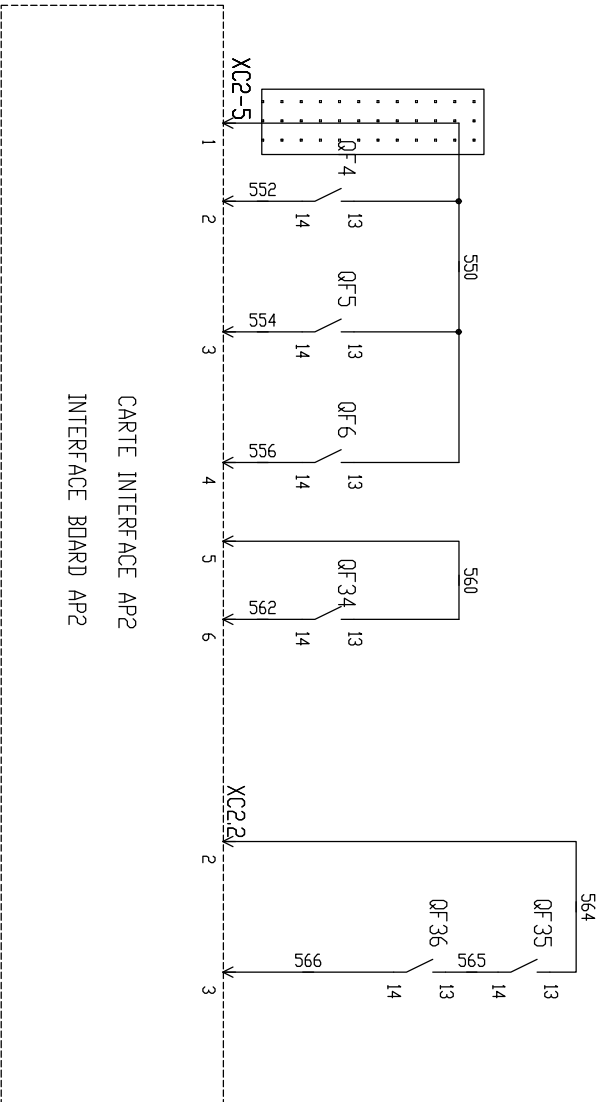

**SCHEMA ELECTRIQUE**

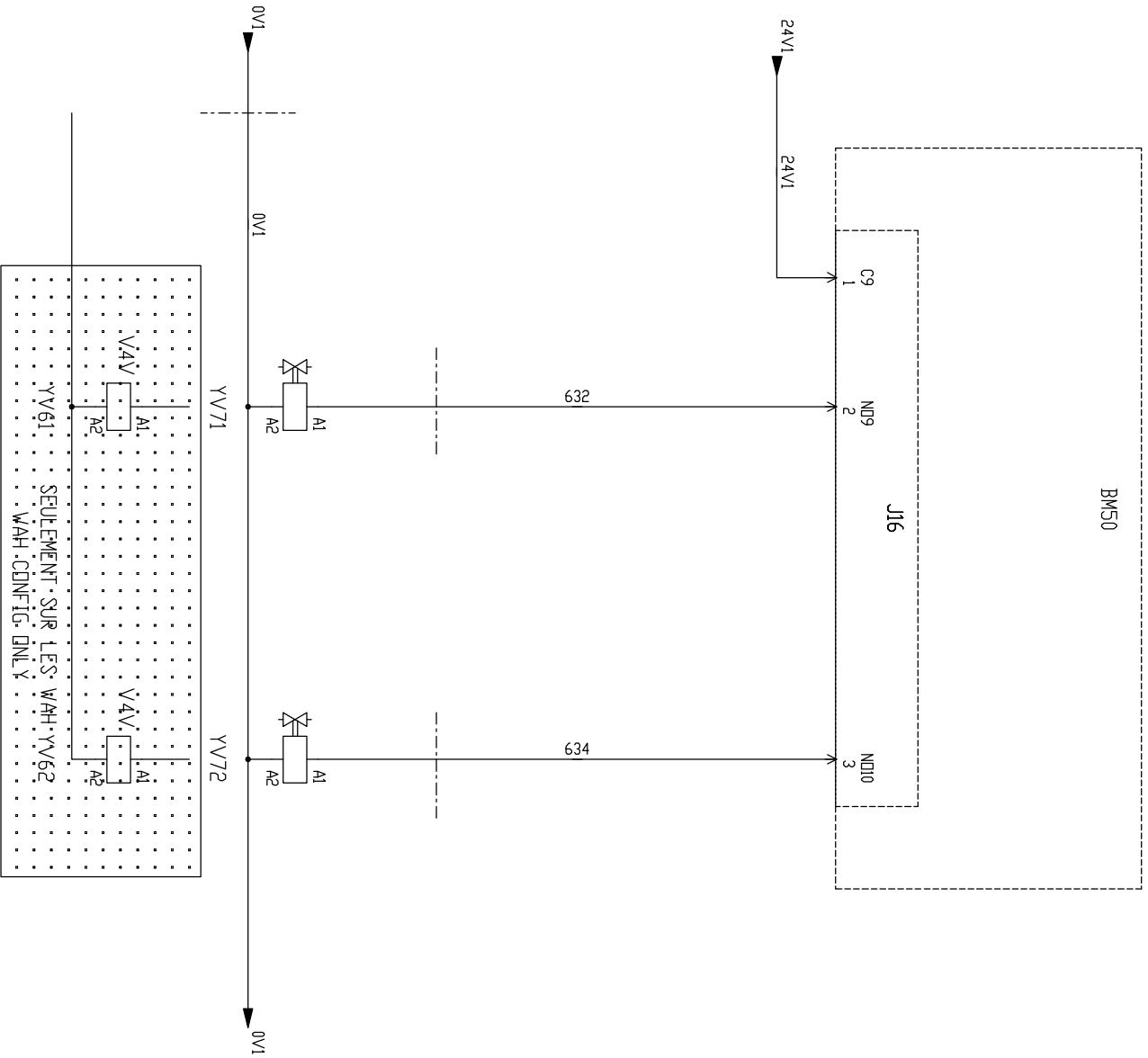

# SCHEMA ELECTRIQUE

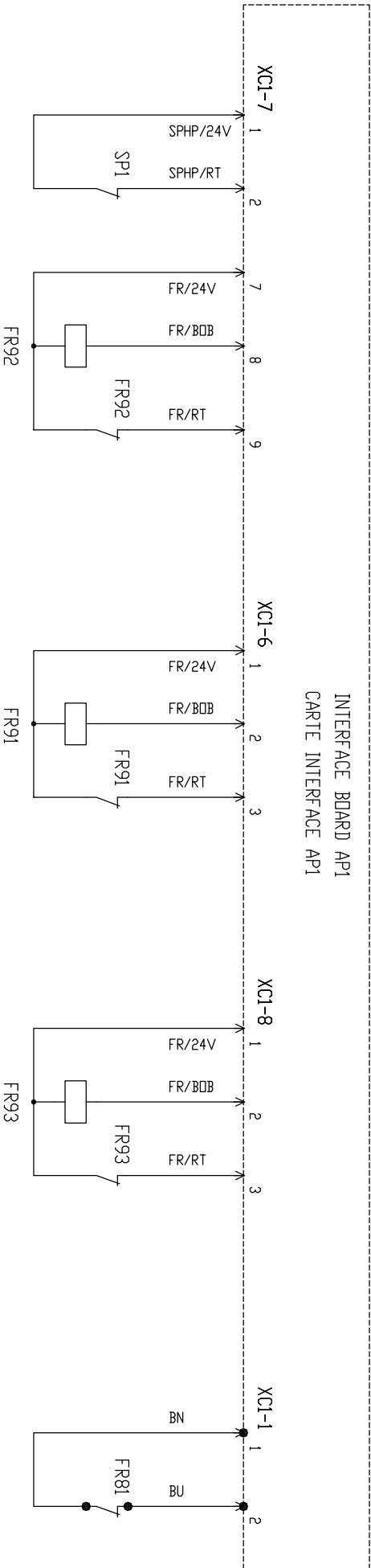

INTERFACE BEARD AP1  
CARTI INTERFACE AP1

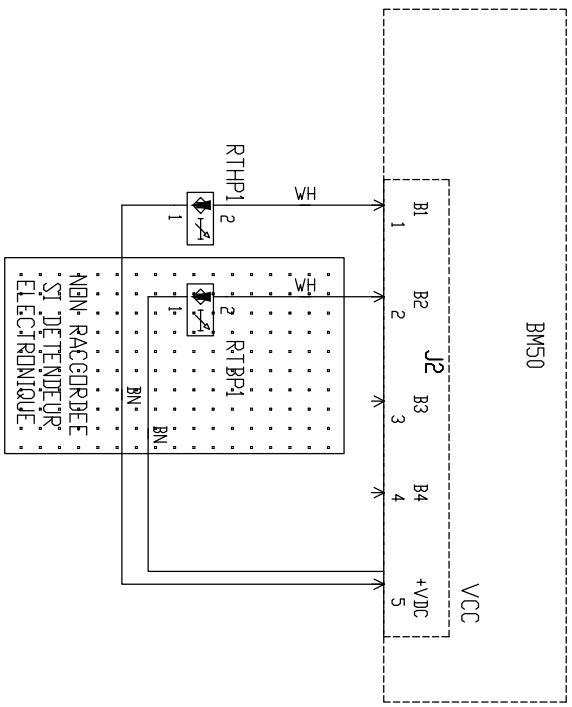

NOT CONNECTED  
IF ELEC EXPANSION VALVE

**SCHEMA ELECTRIQUE**

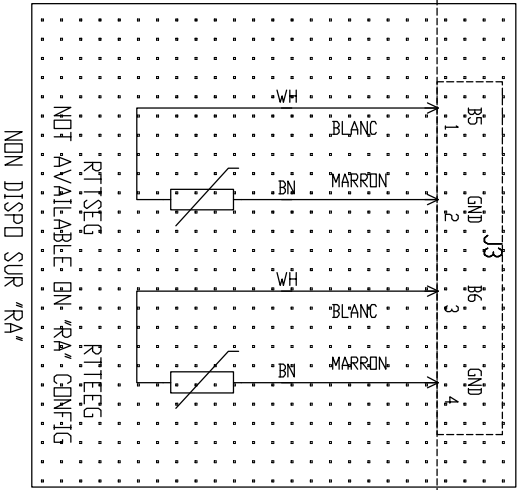

BMS0

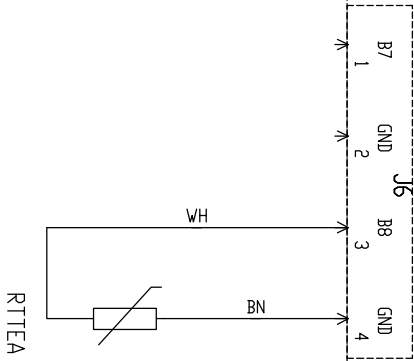

# SCHEMA ELECTRIQUE

INTERFACE BOARD AP2  
 CARTE INTERFACE AP2

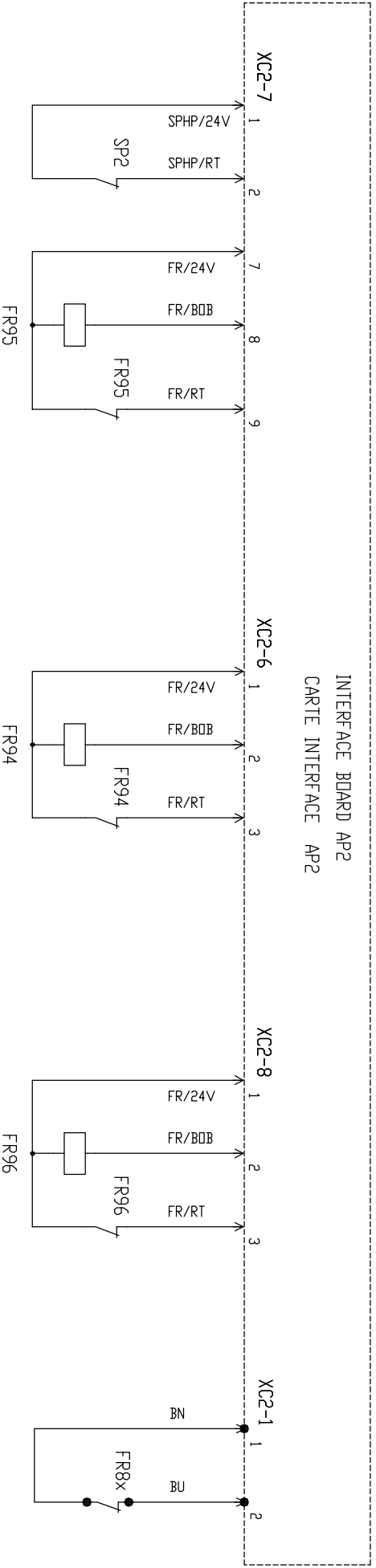

x = 3 IF 4 FAN MOTORS / SI 4 Moto Ventilateurs  
 x = 4 IF 6 FAN MOTORS / SI 6 Moto Ventilateurs

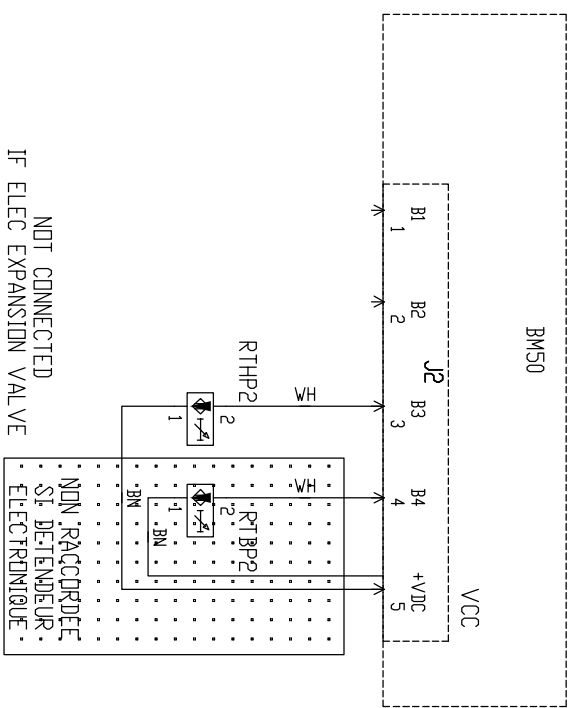

NON RACCORDARE  
 SI DELENDEUR  
 ELECTRONIQUE.

SCHEMA ELECTRIQUE