

*DOSSIER ELECTRIQUE  
ELECTRICAL FILE*

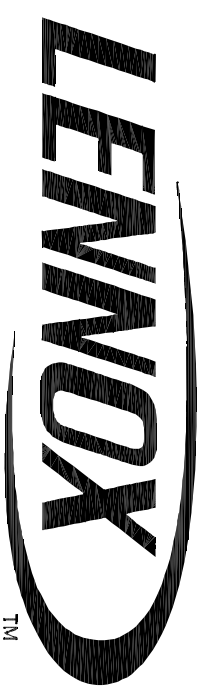

WA 270D K HE

Name / Name

Date: / Date  
26/04/2007

SE135916

1/  
20

CARACTERISTIQUES MACHINE			
MACHINE CHARACTERISTICS			
400 V	Pmax (kW)	Imax (A)	Idem (A)
	137.00	227.00	361.00
3.50Hz			

**CARACTERISTIQUES MOTEURS  
MOTOR CHARACTERISTICS**

REPERE MARKER	DESIGNATION	DESIGNATION	REFERENCE REFERENCE	Pabs. (kW)	Inom. (A)
M1	Compresseur	Compressor motor	ZR310	28.68	46.61
M2	Compresseur	Compressor motor	ZR380	35.24	58.52
M3	Compresseur	Compressor motor	ZR310	28.68	46.61
M4	Compresseur	Compressor motor	ZR380	35.24	58.52
M31	Ventilateur	Fan motor	ZA_900	0.98	1.75
M32	Ventilateur	Fan motor	ZA_900	0.98	1.75
M33	Ventilateur	Fan motor	ZA_900	0.98	1.75
M34	Ventilateur	Fan motor	ZA_900	0.98	1.75
M35	Ventilateur	Fan motor	ZA_900	0.98	1.75
M36	Ventilateur	Fan motor	ZA_900	0.98	1.75
M37	Ventilateur	Fan motor	ZA_900	0.98	1.75
M38	Ventilateur	Fan motor	ZA_900	0.98	1.75

NOMENCLATURE ARMOIRE ELECTRIQUE  
ELECTRIC PANEL ASSEMBLY BILL OF MATERIAL

REPERE MARKER	DESIGNATION	DESIGNATION	FOURNISSEUR SUPPLIER	REFERENCE REFERENCE
AP1	Carte interface circuit 1	Interface board circuit1	INF-03	
AP2	Carte interface circuit 2	Interface board circuit 2	INF-04	
AZ1	Démarrur compresseur M1	Démarrur compresseur M1_AN	ATS01N272Q	
AZ2	Démarrur compresseur M2	Démarrur compresseur M2_AN	ATS01N272Q	
AZ3	Démarrur compresseur M3	Démarrur compresseur M3_AN	ATS01N272Q	
AZ4	Démarrur compresseur M4	Démarrur compresseur M4_AN	ATS01N272Q	
Dép1	Alimentation peigne	Supply cable assembly	GV1G09	
Dép2	Peigne 1	Cable assembly 1	GV2G445	
Dép3	Peigne 2	Cable assembly 2	GV2G345	
KA11	Relais compresseur M1	Compressor relay M1	RXM3AB1B7	
KA11	Relais compresseur M1	Compressor relay M1	RXZE1S111M	
KA11	Relais compresseur M1	Compressor relay M1	RXZR235	
KA12	Relais compresseur M2	Compressor relay M2	RXM3AB1B7	
KA12	Relais compresseur M2	Compressor relay M2	RXZE1S111M	
KA12	Relais compresseur M2	Compressor relay M2	RXZR235	
KA13	Relais compresseur M3	Compressor relay M3	RXM3AB1B7	
KA13	Relais compresseur M3	Compressor relay M3	RXZE1S111M	
KA13	Relais compresseur M3	Compressor relay M3	RXZR235	
KA14	Relais compresseur M4	Compressor relay M4	RXM3AB1B7	
KA14	Relais compresseur M4	Compressor relay M4	RXZE1S111M	
KA14	Relais compresseur M4	Compressor relay M4	RXZR235	
KM32	Contacteur ventilateur M32	Fan contactor M32	GV2ME07K1B7	
KM33	Contacteur ventilateur M33	Fan contactor M33	GV2ME07K1B7	
KM34	Contacteur ventilateur M34	Fan contactor M34	GV2ME07K1B7	
KM36	Contacteur ventilateur M36	Fan contactor M36	GV2ME07K1B7	
KM37	Contacteur ventilateur M37	Fan contactor M37	GV2ME07K1B7	
KM38	Contacteur ventilateur M38	Fan contactor M38	GV2ME07K1B7	
QF1	Disjoncteur compresseur M1	Compressor circuit breaker M1	GV3ME63	
QF2	Disjoncteur compresseur M2	Compressor circuit breaker M2	GV3ME63	
QF3	Disjoncteur compresseur M3	Compressor circuit breaker M3	GV3ME63	
QF31	Disjoncteur ventilateur M31	Fan circuit breaker M31	GV2ME073	
QF35	Disjoncteur ventilateur M35	Fan circuit breaker M35	GV2ME073	
QF4	Disjoncteur compresseur M4	Compressor circuit breaker M4	GV3ME63	
QF70	Disjoncteur primaire TC1	Primary circuit breaker TC1	GB2DB06	
QF72	Disjoncteur secondaire TC1	Secondary circuit breaker TC1	GB2CD12	
QF73	Disjoncteur secondaire TC1	Secondary circuit breaker TC1	GB2CD09	
QF74	Disjoncteur départ résistances	Fan circuit breaker M38	GV2ME073	
QSG	Interrupteur INS 250A - 3P	Interrupteur INS 250A - 3P_AN	31106	
QSG	Répartiteur	Terminal block	4033	
QSG	Cde frontale prolongée	Front operated isolator	31050	
QSG	Cache bornes	Terminal block cover	29324	
QSG	Répartiteur	Terminal block	4155	
TC1	Transformateur contrôle	Transformer 24V	ABL6T525B	

SCHEMA ELECTRIQUE

0	1	2	3	4	5	6	7	8	9
EHI1-->9	Résistance carter Crankcase heater		R	Résistances triphasées 3 phase heater		SP1111-->115	Pressostat HP BP combiné HP LP combined switch		
EHI1-->15	Résistance bouteille Receiver heater		RC	Circuits RC RC circuit		ST11-->15	Thermostat de commande résistances bouteille Receiver control thermostat		
EHI6-->25	Résistance évaporateur Evaporator heater		RT	Sondes ou Capteurs Temperature or pressure sensor		ST16-->25	Thermostat de commande résistances évaporateur Evaporator resistance control thermostat		
EH26-->35	Résistance condenseur Condenser heater		RTTEA	Température d'entrée d'air Air inlet temperature		ST126-->30	Thermostat de commande résistances condenseur Condenser resistance control thermostat		
EH90-->100	Résistances diverses Various heaters		RTTEEG	Température d'entrée d'eau glacée Water inlet temperature		ST56-->65	Thermostat de surchauffe Overheat thermostat		
EH101	Résistance armoire Electrical panel heater		RTTEEG	Température de sortie d'eau glacée Water outlet temperature		ST166-->70	Thermostat de commande ventilateur armoire Electrical panel fan control thermostat		
FR91-->99	Protection moteur compresseur Solid state motor protection		RTTREF	Température de refoulement Discharge temperature		ST71-->75	Thermostat de dégivrage Defrost thermostat		
FU90	Fusibles divers Various fuses		RTTASP	Température d'aspiration Suction temperature		ST76-->85	Thermostat antigel Antifreeze thermostat		
HA	Signalisation sonore Sound signal		RTTBP	Température d'évaporation Evaporating temperature		ST90-->100	Thermostat divers Various thermostats		
HL01	Voyant défaut général General fault light		SA90.	Interrupteurs divers Various switches		V	Diode Diode		
HL1-->9	Voyant marche compresseur Compressor operating light		SB90.	Boutons poussoirs divers Various push buttons		VOP1	Optocoupleur Optoelectronic coupler		
HL11-->20	Voyant marche ventilateur Fan running light signal		SD1	Contrôleur de débit Flow switch		XB	Barrette sectionnable Isolator link		
HL25-->29	Voyant défaut pompe Pump fault light signal		SL1-->5	Contrôleur de niveau d'eau Water Level controller		XS90	Prise de courant plug		
HL30	Voyant sous tension Voltage ON light signal		SL16-->20	Contrôleur de niveau d'huile Oil level controller		YP1-->5	Détendeur électronique Electronic expansion valve		
HL31-->39	Voyant arrêt contrôle Control shutdown light signal		SP1-->9	Pressostat HP sécurité HP pressure switch		YV1-->5	Électrovanne liquide liquid line solenoid valve		
HL41-->49	Voyant arrêt sécurité Safety shutdown light signal		SP11-->15	Pressostat BP sécurité BP pressure switch		YV6-->15	Électrovanne réduction de puissance compresseur Compressor capacity reduction solenoid valve		
HL51-->60	Voyant défaut ventilateur Fan shutdown light signal		SP16-->25	Pressostat d'huile Oil pressure switch		YV16-->20	Électrovanne injection de liquide Liquid injection solenoid valve		
HL65-->69	Voyant marche pompe Pump operation light		SP26-->30	Pressostat BP antigel Antifreeze LP pressure switch		YV21-->25	Électrovanne économiseur Economizer solenoid valve		
HL90	Voyant divers Various light signal		SP31-->50	Pressostat HP de commande ventilateur Fan control HP pressure switch		YV26-->35	Électrovanne by-pass compresseur Compressor by-pass solenoid valve		
KA50-->75	Relais divers Various relays		SP51-->55	Pressostat HP de commande résistance bouteille Receiver heater HP pressure switch		YV36-->40	Électrovanne gaz chauds pressostatique Pressure control hot gas solenoid valve		
KM90	Contacteurs divers Various contactors		SP56-->60	Pressostat HP de commande vanne décharge bouteille Discharge valve HP pressure switch		YV41-->45	Électrovanne gaz chauds thermostatique Thermostatic hot gas solenoid valve		
KT90	Relais temporisés divers Various time delayed relays		SP61-->65	Pressostat HP de commande de délestage Overload control HP pressure switch		YV61-->70	Électrovanne inversion de cycle 4 way reversing solenoid valve		
M111	Ventilateur de culasse compresseur Compressor cylinder head fan		SP71-->75	Pressostat de commande by-pass détenteur Expansion valve by-pass control pressure switch		YV71-->75	Électrovanne by-pass détenteur Thermostatic expansion valve by-pass solenoid valve		
P1	Afficheur Display		SP90-->110	Pressostats divers Various pressure switch		YV90	Électrovanne diverses Various solenoid valves		

SE135916

## SCHEMA ELECTRIQUE

0	1	2	3	4	5	6	7	8	9
EH1-->9	Crankcase heater		R	3 phase heater		SP111-->115	HP LP combined switch		
EH1-->15	Receiver heater		RC	RC circuit		ST11-->15	Receiver control thermostat		
EH16-->25	Evaporator heater		RT	Temperature or pressure sensor		ST16-->25	Evaporator resistance control thermostat		
EH26-->35	Condenser heater		RTTEA	Air inlet temperature		ST126-->30	Condenser resistance control thermostat		
EH90-->100	Various heaters		RTTEEG	Water inlet temperature		ST56-->65	Overheat thermostat		
EH101	Electrical panel heater		RTTSEG	Water outlet temperature		ST166-->70	Electrical panel fan control thermostat		
FR91-->99	Solid state motor protection		RTTREF	Discharge temperature		ST71-->75	Defrost thermostat		
FU90	Various fuses		RTTASP	Suction temperature		ST76-->85	Antifreeze thermostat		
HA	Sound signal		RTTBP	Evaporating temperature		ST90-->100	Various thermostat		
HL01	General fault light		SA90.	Various switches		V	Diode		
HL1-->9	Compressor operating light		SB90.	Various push buttons		V0PT	Optoelectronic coupler		
HL11-->20	Fan running light signal		SD1	Flow switch		XB	Isolator link		
HL25-->29	Pump fault light signal		SL1-->5	Water level controller		XS90	plug		
HL30	Voltage ON light signal		SL16-->20	Oil level controller		YP1-->5	Electronic expansion valve		
HL31-->39	Control shutdown light signal		SP1-->9	HP pressure switch		YV1-->5	liquid line solenoid valve		
HL41-->49	Safety shutdown light signal		SP11-->15	BP pressure switch		YV6-->15	Compressor capacity reduction solenoid valve		
HL51-->60	Fan shutdown light signal		SP16-->25	Oil pressure switch		YV16-->20	Liquid injection solenoid valve		
HL65-->69	Pump operation light		SP26-->30	Antifreeze LP pressure switch		YV21-->25	Economizer solenoid valve		
HL90	Various light signal		SP31-->50	Fan control HP pressure switch		YV26-->35	Compressor by-pass solenoid valve		
KA50-->75	Various relays		SP51-->55	Receiver heater HP pressure switch		YV36-->40	Pressure control hot gas solenoid valve		
KM90	Various contactors		SP56-->60	Discharge valve HP pressure switch		YV41-->45	Thermostatic hot gas solenoid valve		
KT90	Various time delayed relays		SP61-->65	Overload control HP pressure switch		YV61-->70	4 way reversing solenoid valve		
M111	Compressor cylinder head fan		SP71-->75	Expansion valve by-pass control pressure switch		YV71-->75	Thermostatic expansion valve by-pass solenoid valve		
P1	Display		SP90-->110	Various pressure switch		YV90	Various solenoid valves		

SE135916

# SCHEMA ELECTRIQUE

0 1 2 3 4 5 6 7 8 9

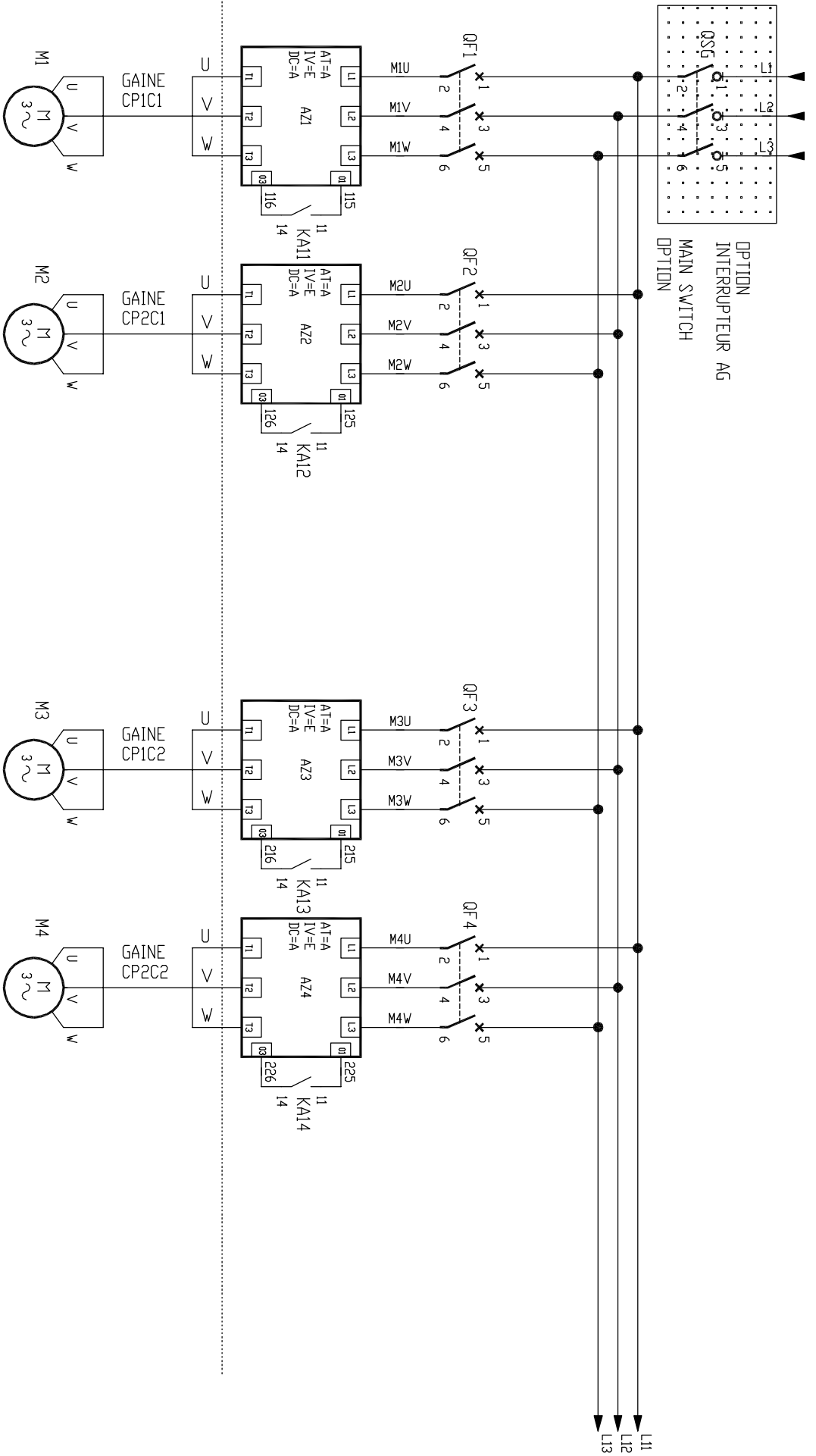

FOR SFTSTARTER ATSO1N2220N AND ATSO1N2320N  
 POUR LES ATSO1N2220N ET ATSO1N2320N  
 BORNE 01 = L1+  
 BORNE 03 = L12

SCHEMA ELECTRIQUE

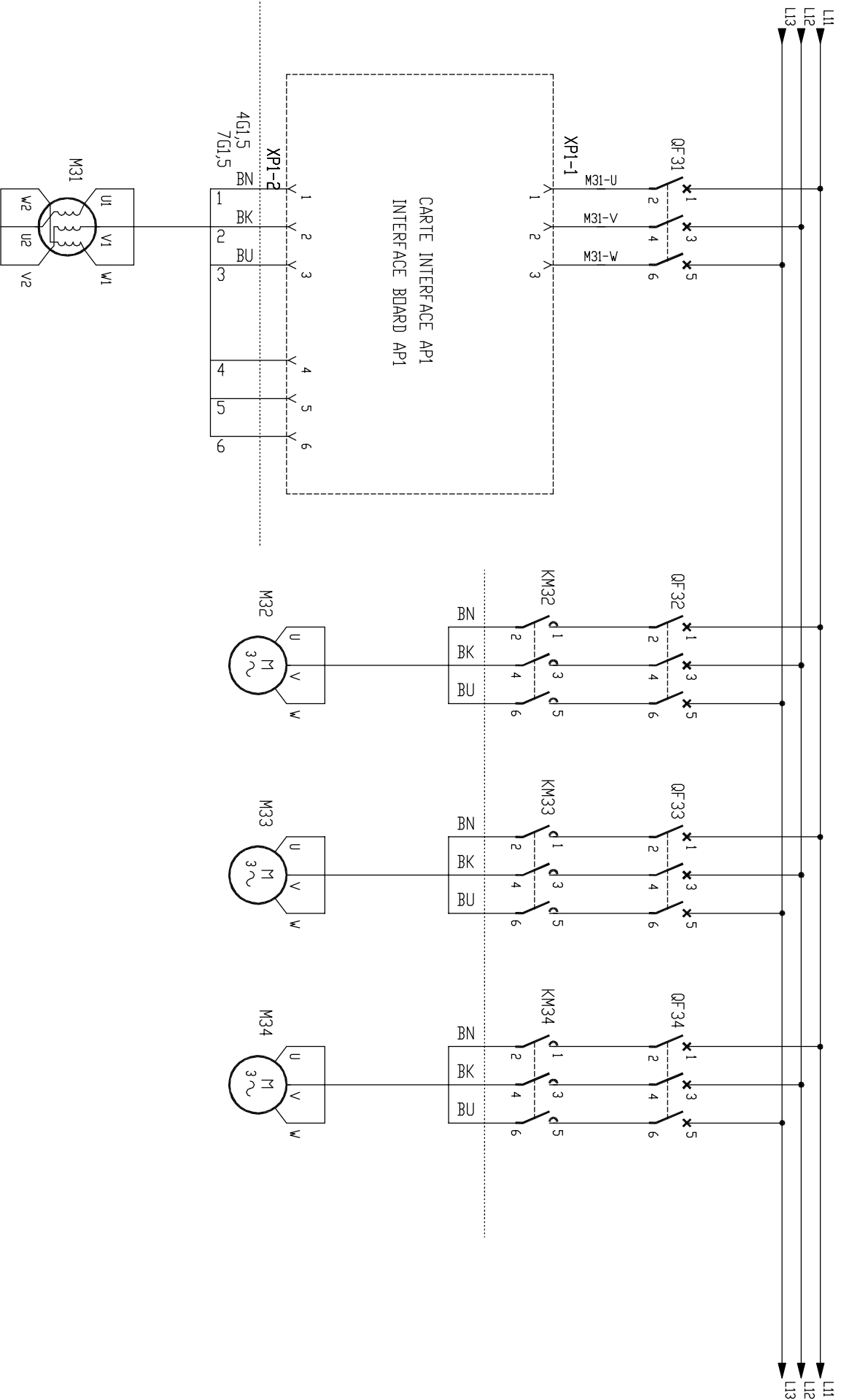

**SCHEMA ELECTRIQUE**

0 1 2 3 4 5 6 7 8 9

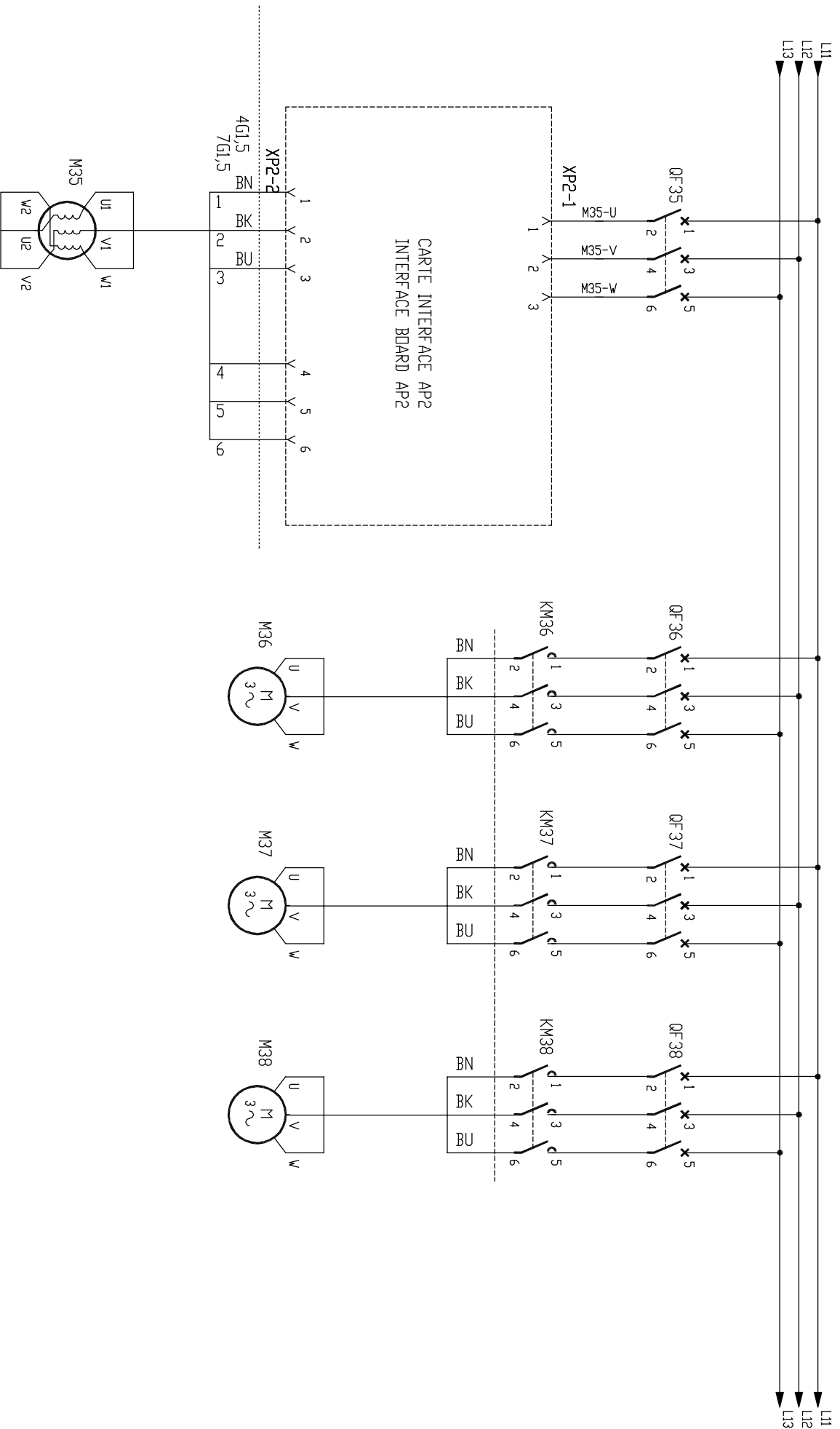

**SCHEMA ELECTRIQUE**



HF · SOFTSTARTER · OPTION · LH4 · KM1 → · KA11 · . . . . . KM3 → · KA13 · . . .  
 ST · DEM · ELEC · OPTION · CH4 · . . . KM2 → · KA12 · . . . . . KM4 → · KA14 · . . .

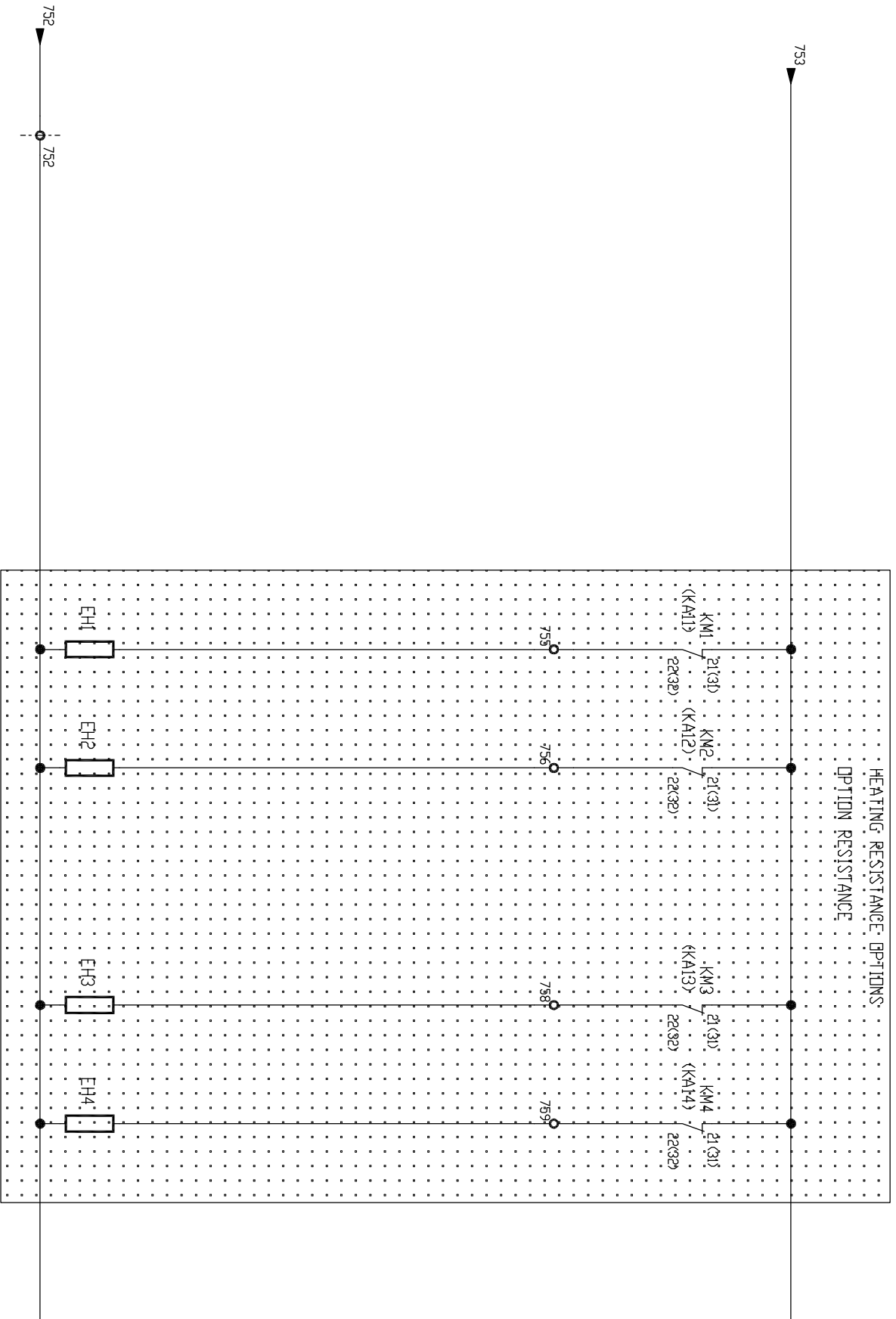

SCHEMA ELECTRIQUE

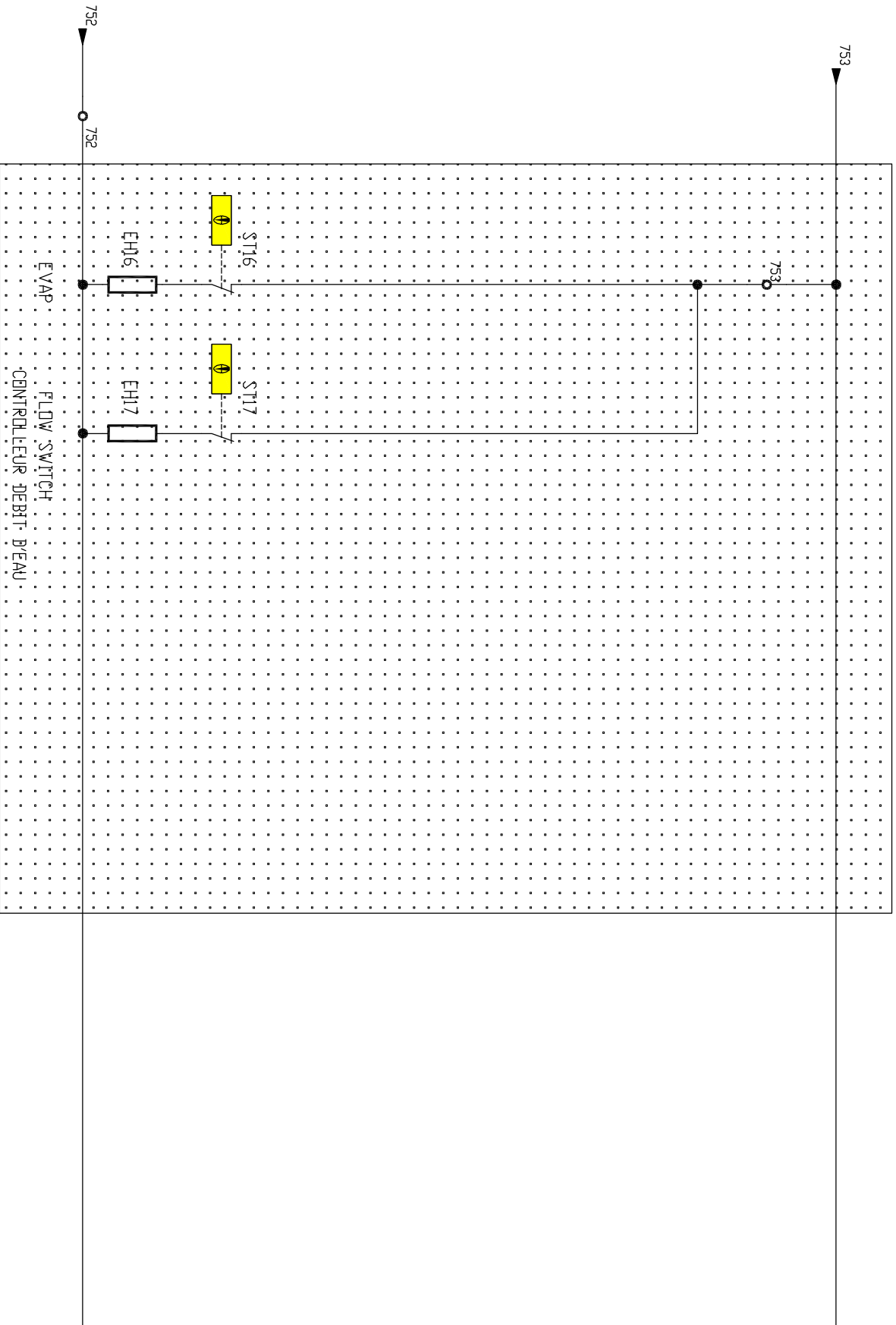

# SCHEMA ELECTRIQUE

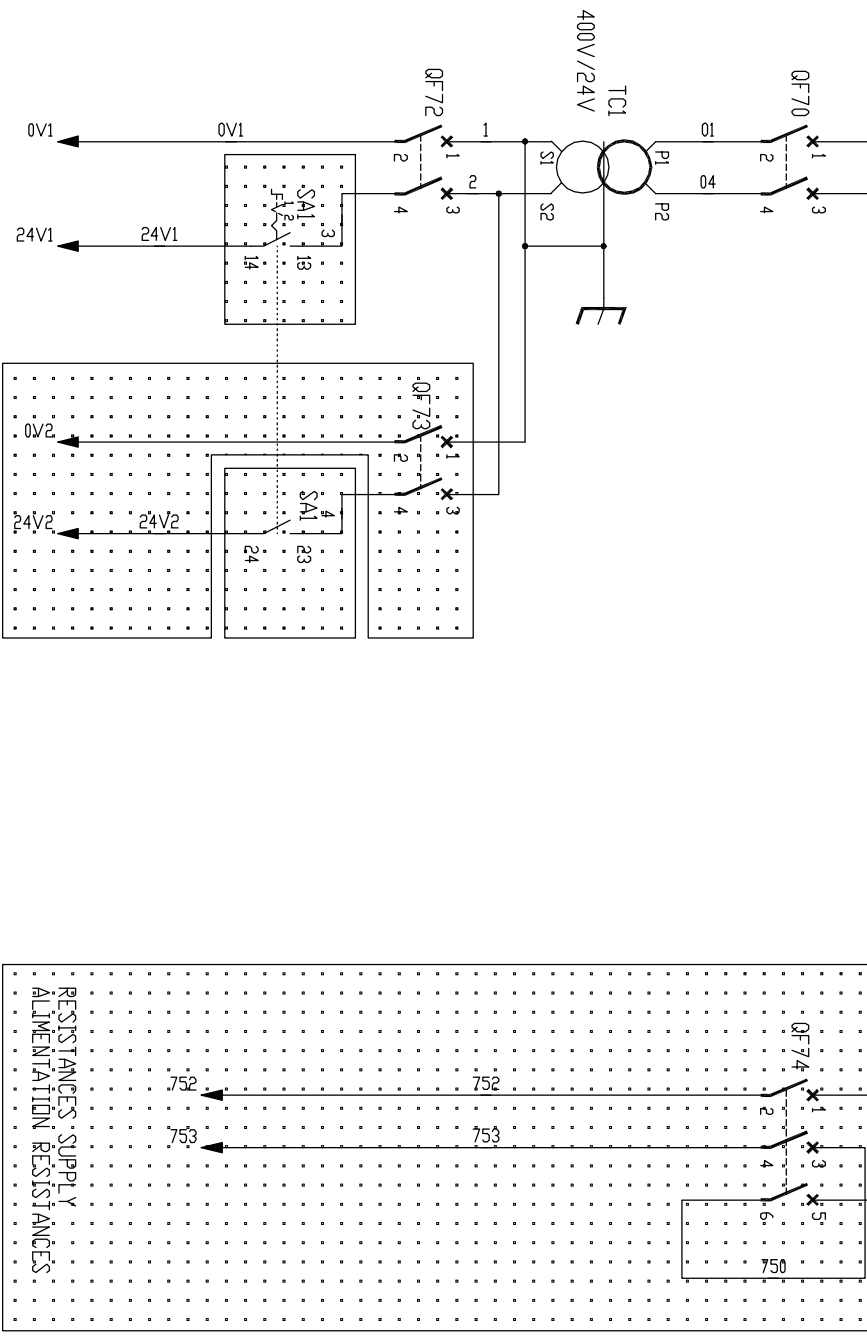
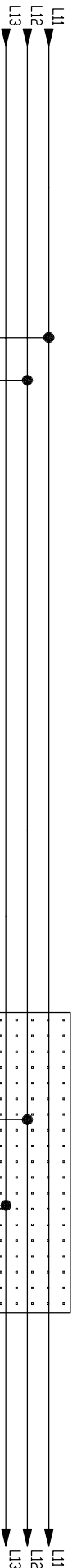

IF ND OPTIION  
 MAINS SWITCH  
 SAI DOOR MOUNTED

SI PAS OPTIION  
 INTERRUPTEUR AG  
 SAI SUR PORTE

SI POWER  
 TRANSFD >250 VA

CONTROL POWER SUPPLY  
 ALIMENTATION CONTROL

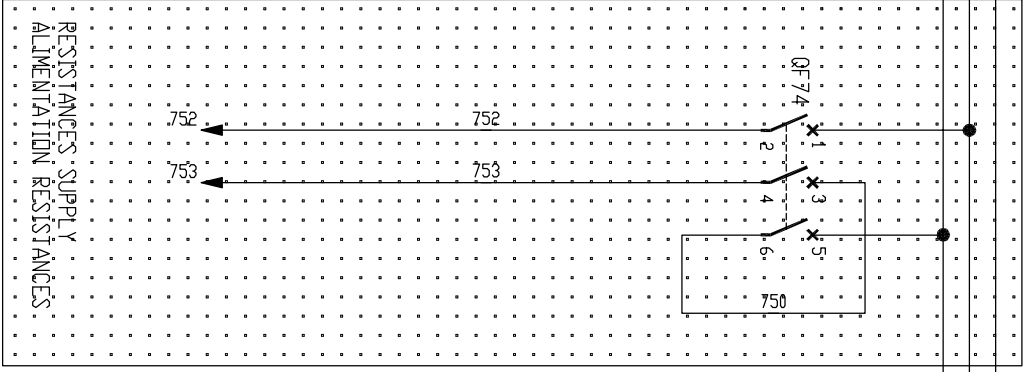

# SCHEMA ELECTRIQUE

0 1 2 3 4 5 6 7 8 9

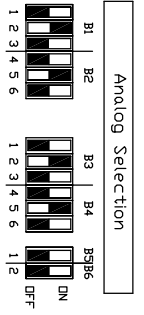
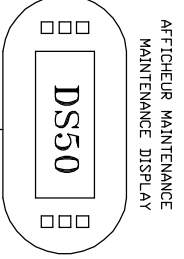
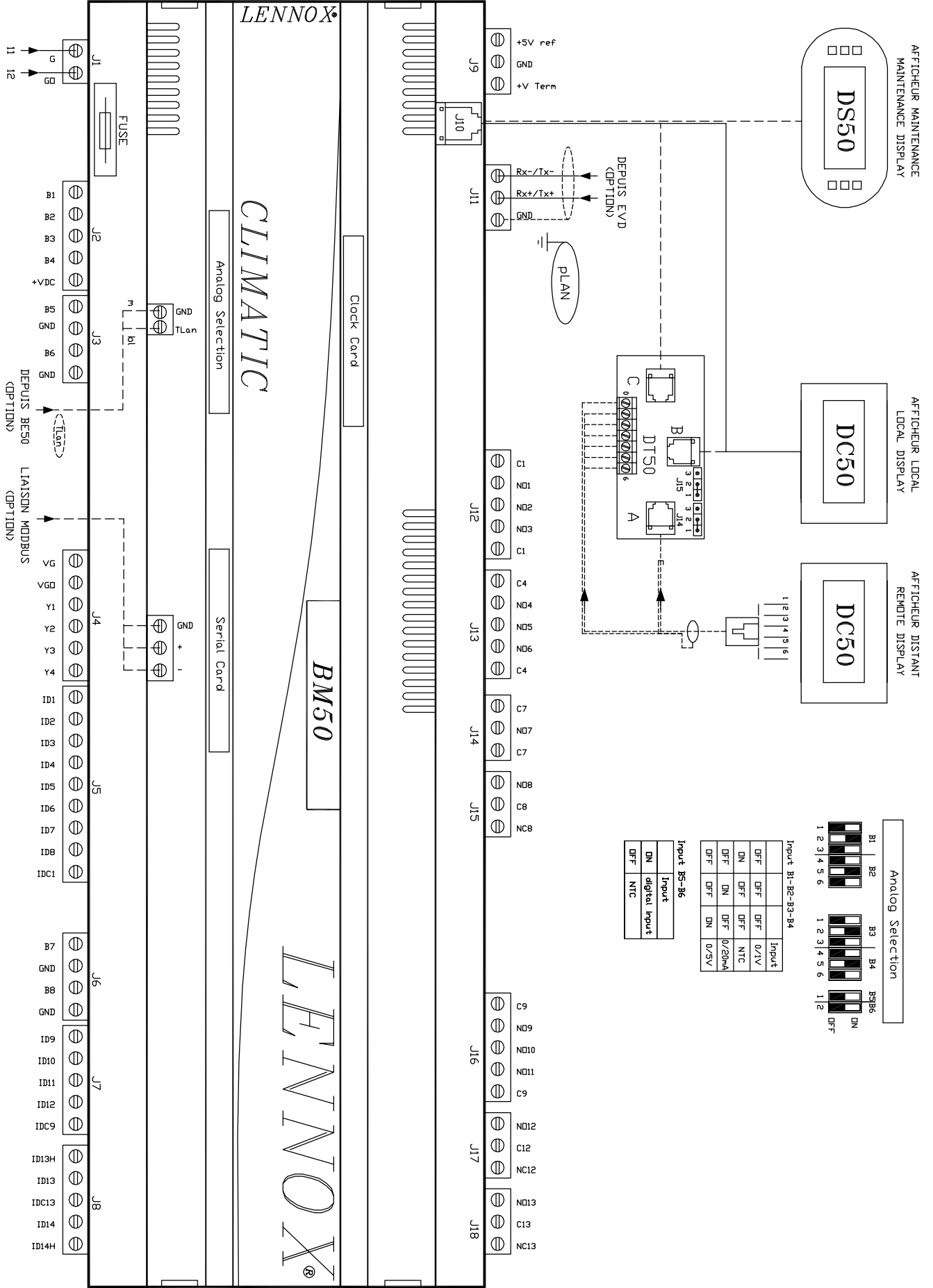

Input B1-B2-B3-B4	Input
OFF	OFF
OFF	0/1V
DN	OFF
OFF	NTC
OFF	DN
OFF	0/20mA
OFF	DN
OFF	0/5V

Input B5-B6	Input
DN	digital input
OFF	NTC

LENNOX®

CLIMATIC

BM50

LENNOX®

Clock Card

Analog Selection

Serial Card

J1  
11 12

J2  
B1 B2 B3 B4 +VDC B5 B6 B7 B8

J3  
n TL n

DEPUIS BE50 (OPTIONN)

LAISON MODBUS (OPTIONN)

J4  
V5 V6 1 2 3 4

J5  
1D1 1D2 1D3 1D4 1D5 1D6 1D7 1D8 1D9 1D10 1D11 1D12 1D13 1D14

J6  
87 88 89 90

J7  
91 92 93 94 95 96 97 98 99 100

J8  
101 102 103 104 105 106 107 108 109 110 111 112 113 114 115 116 117 118 119 120

SCHEMA ELECTRIQUE

IF: SOFTSTARTER OPTION LH4 KM1 --> KA11  
 Si option démarreur LH4 : KM2 --> KA12

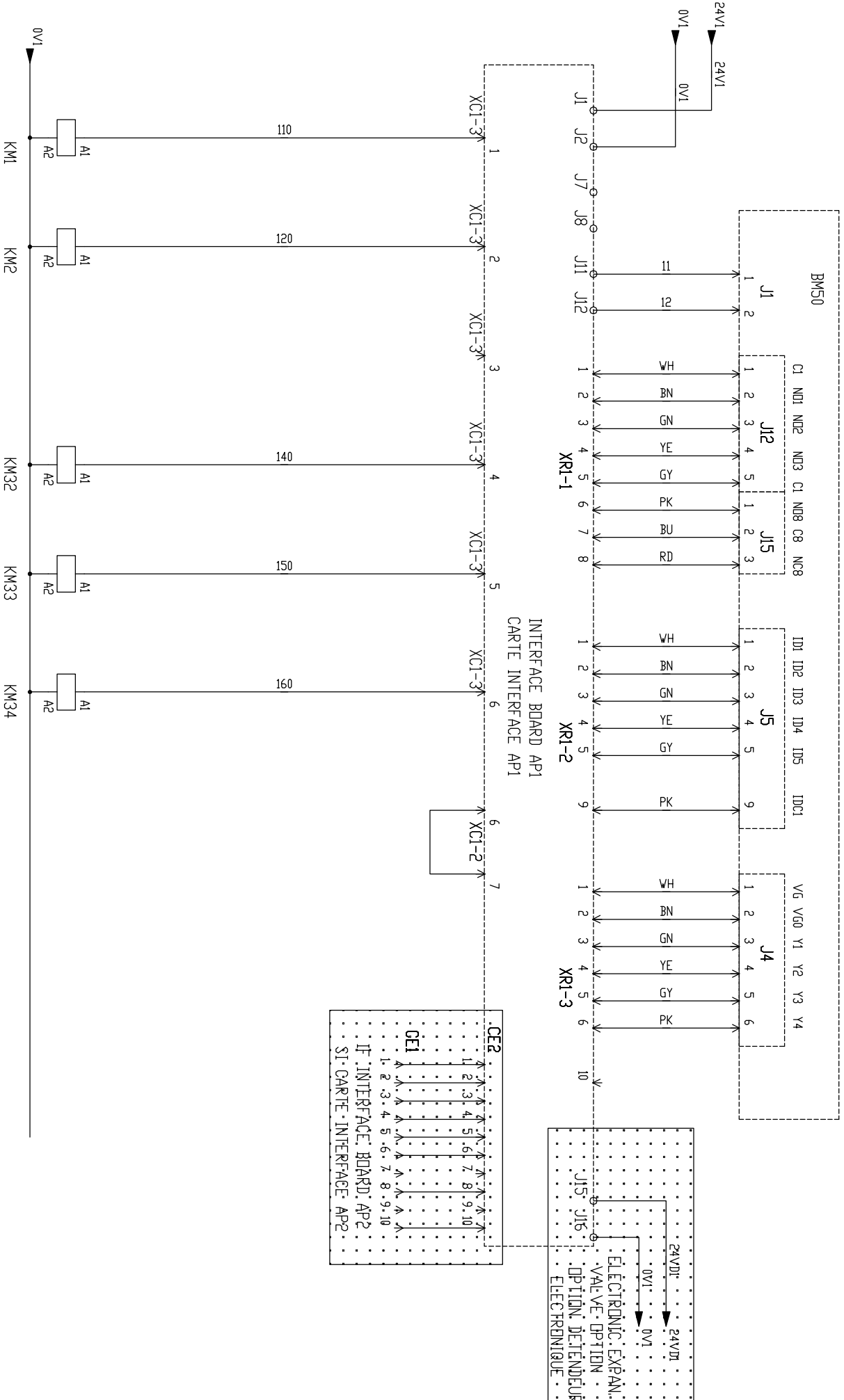

SCHEMA ELECTRIQUE

-IF SOFTSTARTER OPTION LH4: KM3 -> KA13  
 -Si option démarreur LH4: KM4 -> KA14

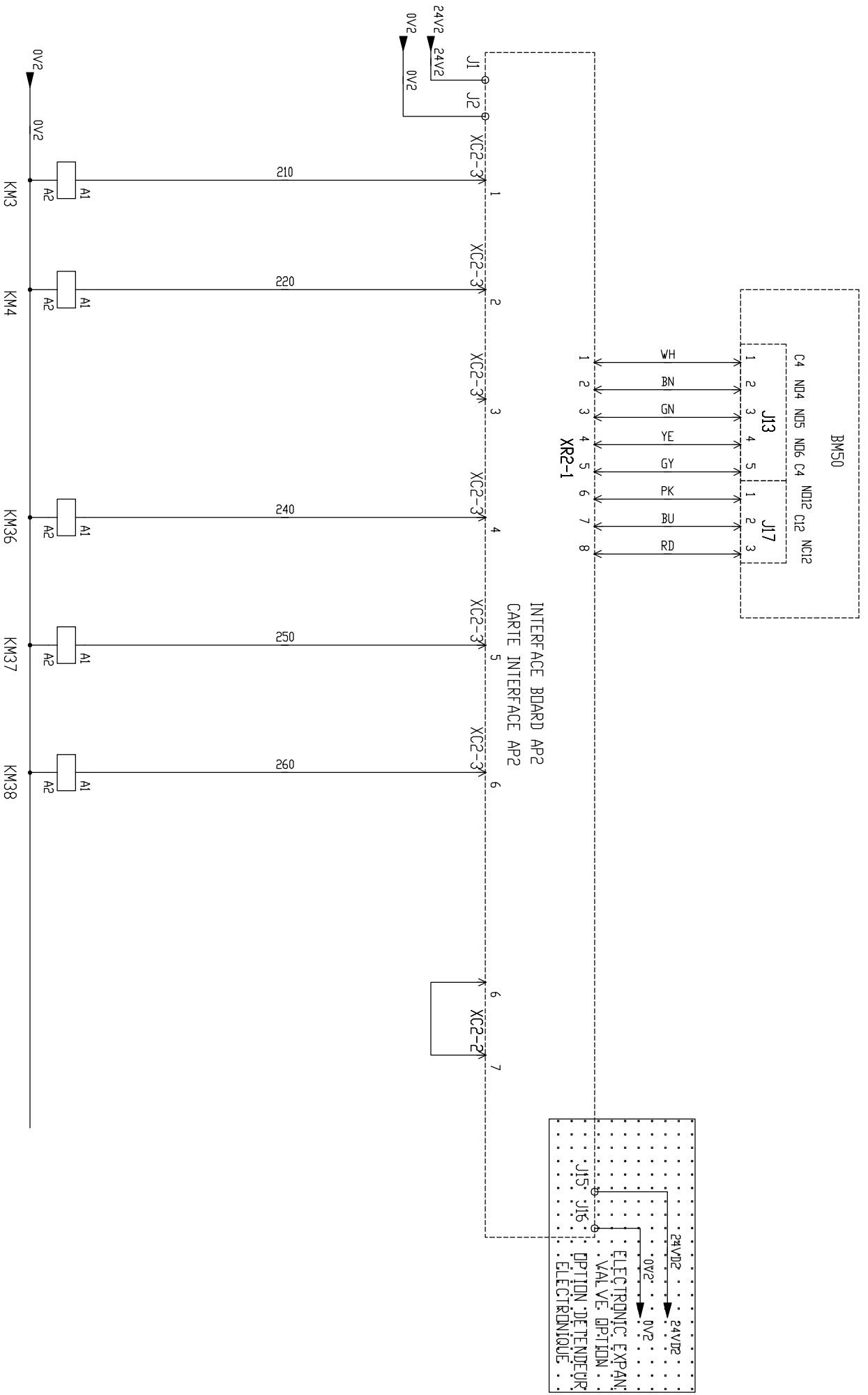

INTERFACE BOARD AP2  
 CARTE INTERFACE AP2

# SCHEMA ELECTRIQUE

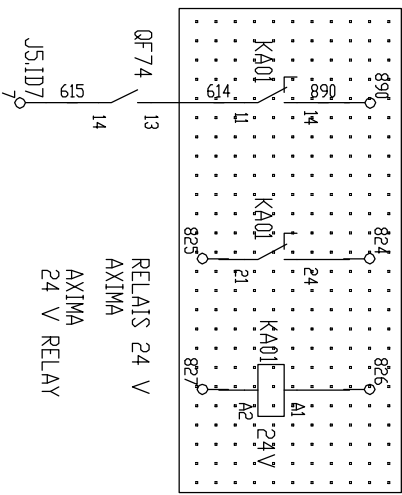
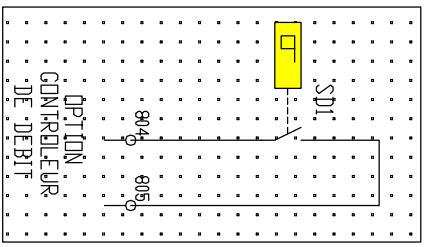
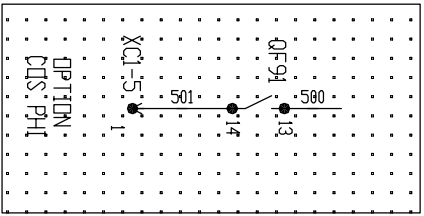
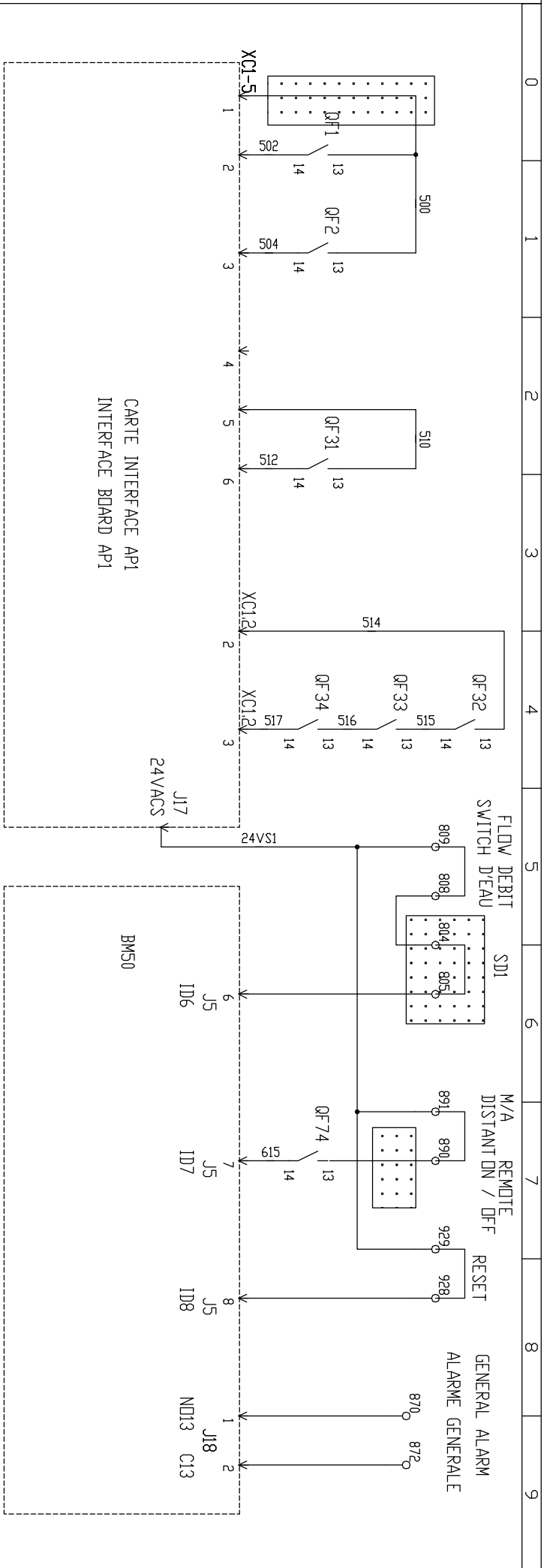

# SCHEMA ELECTRIQUE

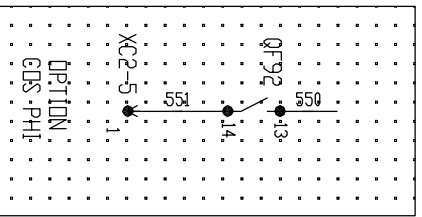
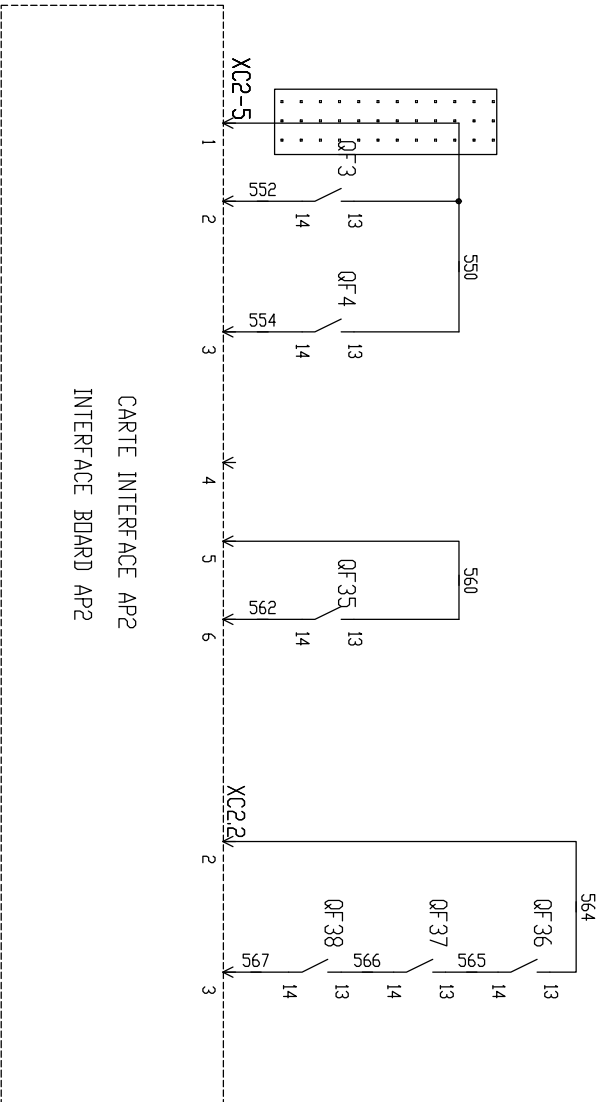

# SCHEMA ELECTRIQUE



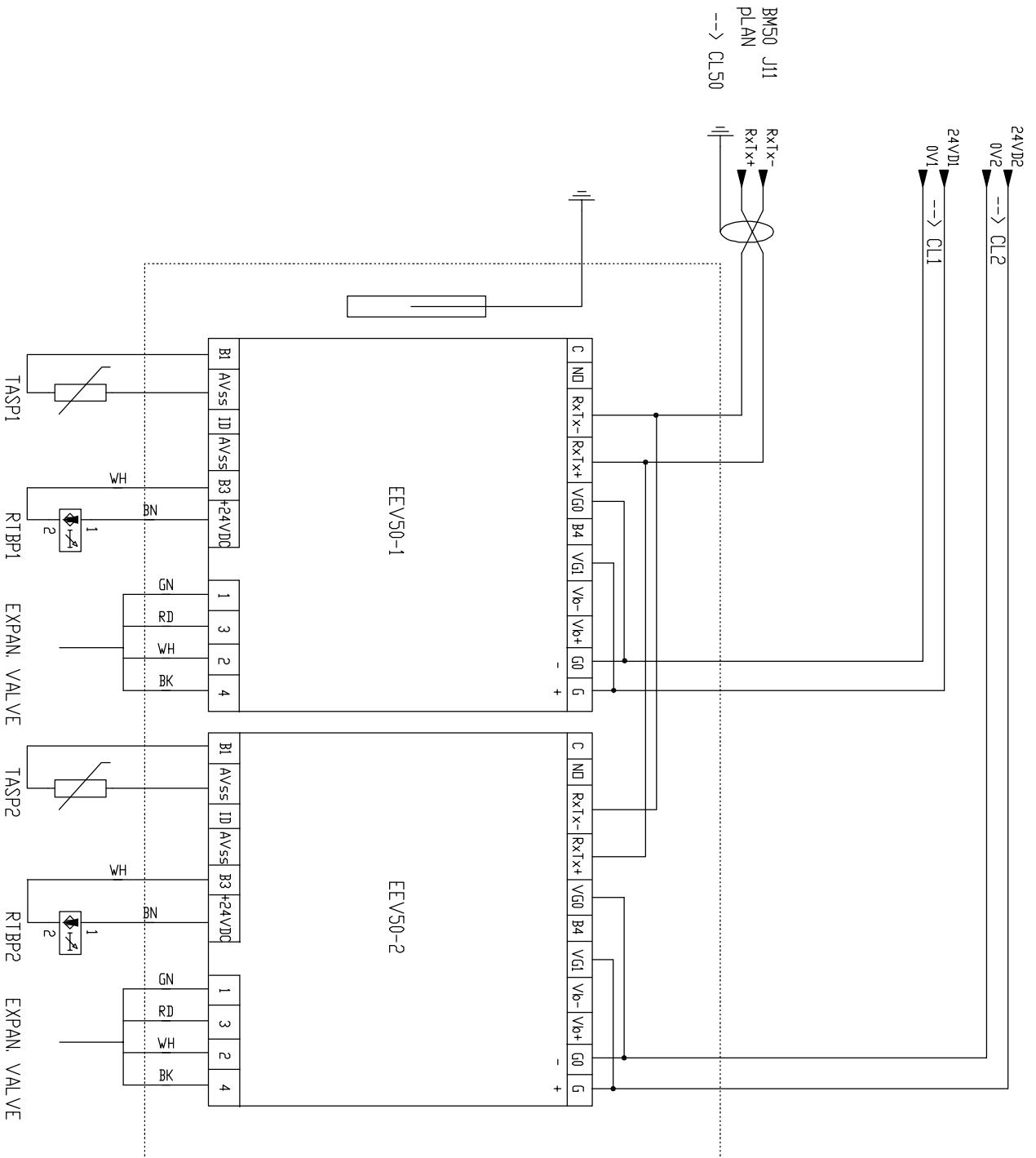

**SCHEMA ELECTRIQUE**

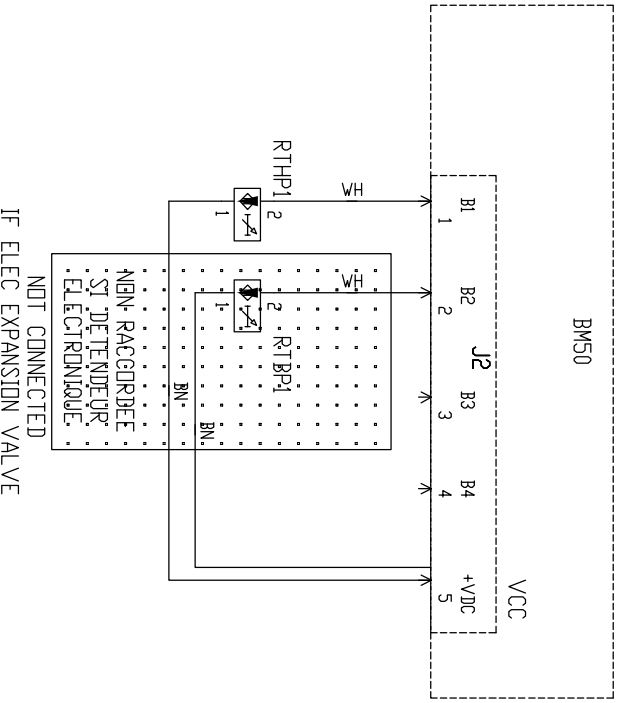
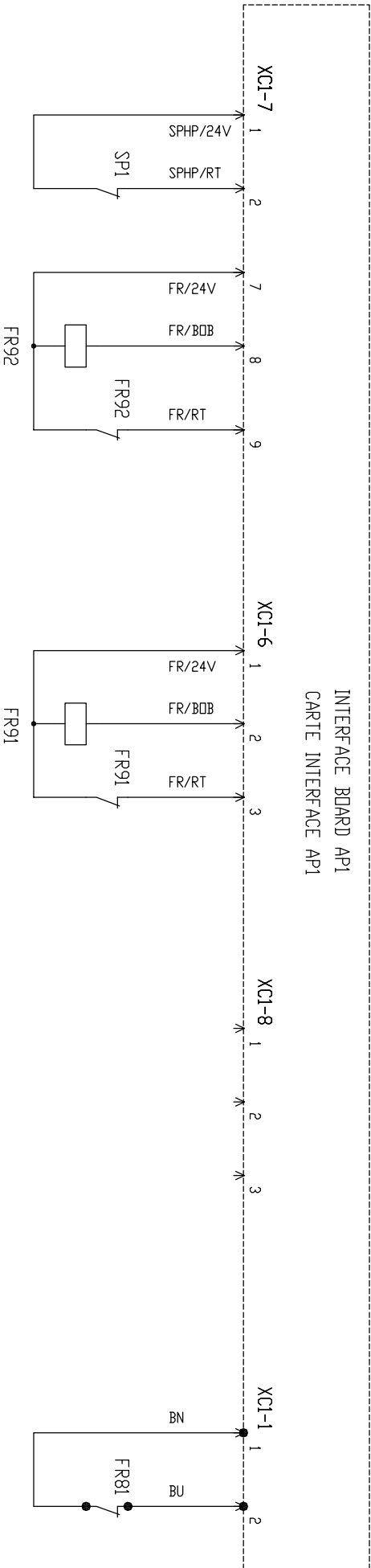

NOT CONNECTED  
IF ELEC EXPANSION VALVE

# SCHEMA ELECTRIQUE

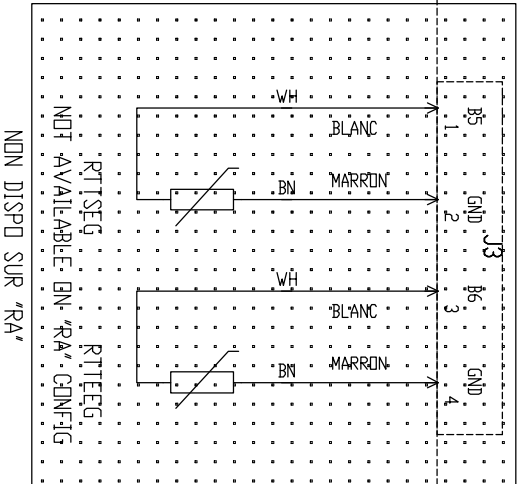

BM50

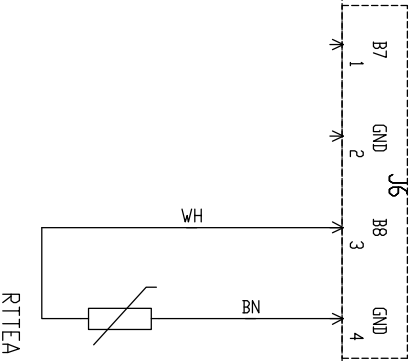

# SCHEMA ELECTRIQUE

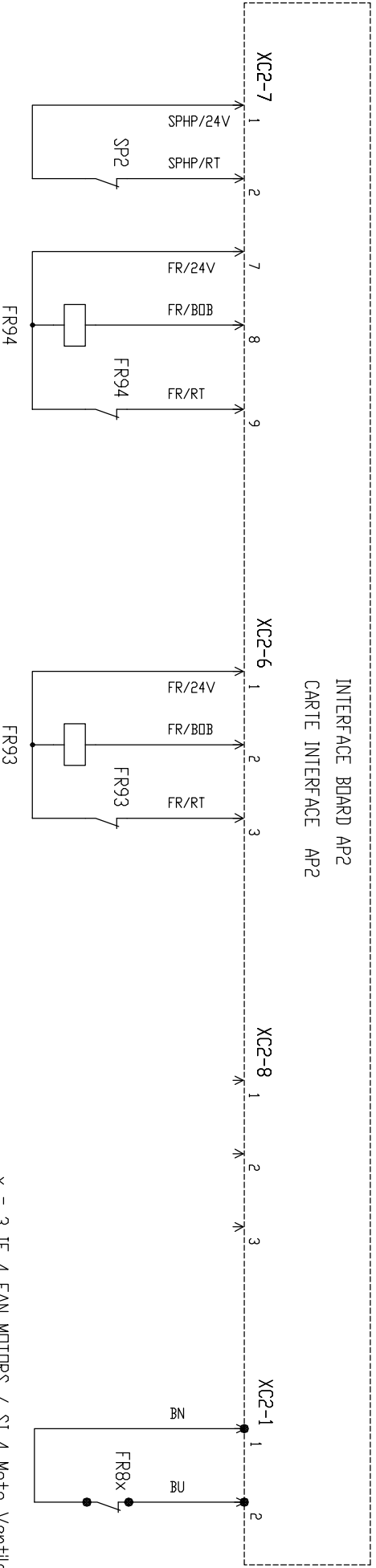

INTERFACE BOARD AP2  
CARTI INTERFACE AP2

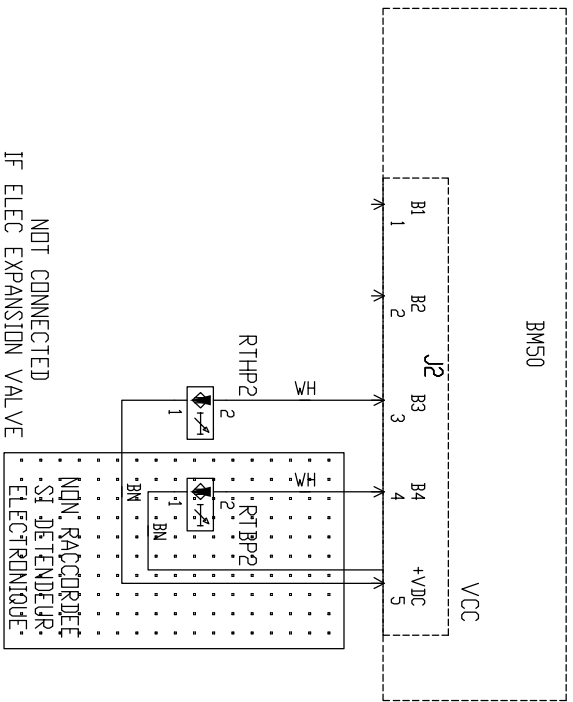

x = 3 IF 4 FAN MOTORS / SI 4 Moto Ventilateurs  
x = 4 IF 6 FAN MOTORS / SI 6 Moto Ventilateurs

**SCHEMA ELECTRIQUE**