





Installation, operating and maintenance **MINIAIR / MINIAIR +**



- Providing indoor climate comfort



SYMBOLOLOGY

| | |
|---|---|
|  | ATTENTION |
|  | DANGER |
|  | a) HIGH RISK OF ELECTRIC SHOCK |
|  | b) ATTENTION: AUTHORIZED PERSONNEL ONLY |

INDEX

MiniAir

SECTION 1 – PRESENTATION

- 1.1 Manual Presentation page 4
- 1.2 Unit Identification page 4

SECTION 2 – TECHNICAL CHARACTERISTICS

- 2.1 Unit dimensions page 5
- 2.2 Unit technical data page 6

SECTION 3 – TRANSPORTATION

- 3.1 Packing page 6
- 3.2 Transportation page 6
- 3.3 Checklist page 6
- 3.4 Storing page 6

SECTION 4 – INSTALLATION & CONNECTION

- 4.1 Definition page 7
- 4.2 Safety Regulations page 7
- 4.3 Preliminary operations page 8
- 4.4 Choosing installation position page 8
- 4.5 Connecting accessories page 8
- 4.6 MINIAIR unit positioning page 9
- 4.7 Duct connection page 10
- 4.8 Hydraulic connection page 10
- 4.9 Electrical connections page 11

SECTION 5 – PRE START CHECKLIST

- 5.1 Checks prior to initial Start-up page 12

SECTION 6 – STANDARD MAINTENANCE

- 6.1 Monthly maintenance page 12
- 6.2 Yearly maintenance page 13

SECTION 7 – TROUBLESHOOTING

- 7.1 Finding faults page 13

SECTION 8 – SPARE PARTS

- 8.1 Spare part order page 14

SECTION 9 – MATERIAL DISPOSAL

- 9.1 Material disposal page 14

MiniAir +

SECTION 10 – PRESENTATION

- 10.1 Manual presentation page 15
- 10.2 Machine identification page 15

SECTION 11 – TECHNICAL CHARACTERISTICS

- 11.1 General characteristics page 15
- 11.2 Accessories page 15
- 11.3 Packing dimensions page 16
- 11.4 Unit technical data page 17
- 11.5 Accessories technical data page 18
- 11.6 Possible positioning page 19
- 11.7 By-pass for de-frosting or free-cooling page 21

SECTION 12 – TRANSPORTATION

| | | |
|------|----------------|---------|
| 12.1 | Packing | page 21 |
| 12.2 | Transportation | page 22 |
| 12.3 | Checklist | page 22 |
| 12.4 | Storing | page 22 |

SECTION 13 – INSTALLATION & CONNECTION

| | | |
|------|---------------------------------------|---------|
| 13.1 | Definition | page 22 |
| 13.2 | Safety regulations | page 22 |
| 13.3 | Preliminary operations | page 23 |
| 13.4 | Choosing place of installation | page 23 |
| 13.5 | Machine positioning | page 24 |
| 13.6 | Duct connection | page 25 |
| 13.7 | Hydraulic connection | page 26 |
| 13.8 | Electrical connection | page 27 |
| 13.9 | Installation of CVU & PCU accessories | page 27 |

SECTION 14 – ELECTRICAL SCHEMES

| | | |
|-------|--|---------|
| 14.1 | MINIAIR+ 03-06 direct connection | page 29 |
| 14.2 | MINIAIR+ 03-06 connection with CVU speed control | page 29 |
| 14.3 | MINIAIR+ 03-06 connection with SKE & PCU control panel | page 30 |
| 14.4 | MINIAIR+ 10-14-19-25 direct connection | page 30 |
| 14.5 | MINIAIR+ 10-14-19-25 connection with CVU speed control | page 31 |
| 14.6 | MINIAIR+ 10-14-19-25 connection with SKE & PCU control panel | page 31 |
| 14.7 | MINIAIR+ 30 direct connection | page 32 |
| 14.8 | MINIAIR+ 30 connection with CVU speed control | page 32 |
| 14.9 | MINIAIR+ 30 connection with SKE & PCU control panel | page 33 |
| 14.10 | MINIAIR+ 40 direct connection | page 33 |
| 14.11 | MINIAIR+ 40 connection with CVU speed control | page 34 |
| 14.12 | MINIAIR+ 40 connection with SKE & PCU control panel | page 34 |

SECTION 15 – PRE-START CHECKLIST

| | | |
|------|----------------------------------|---------|
| 15.1 | Checks prior to initial start-up | page 35 |
|------|----------------------------------|---------|

SECTION 16 – STANDARD MAINTENANCE

| | | |
|------|---------------------|---------|
| 16.1 | Monthly maintenance | page 35 |
| 16.2 | Yearly maintenance | page 36 |

SECTION 17 – TROUBLESHOOTING

| | | |
|------|----------------------------|---------|
| 17.1 | Localisation of breakdowns | page 37 |
|------|----------------------------|---------|

SECTION 18 – MATERIAL DISPOSAL

| | | |
|------|-------------------|---------|
| 18.1 | Material disposal | page 37 |
|------|-------------------|---------|

MINIAIR

SECTION 1 – PRESENTATION

1.1 Manual Presentation

This instruction manual supplies the necessary information for the transportation, the installation, operation and maintenance of the **MINIAIR** apparatus as supplied by the company LENNOX (from this point named as the supplier). It supplies the user with as much information as is normally useful for a correct and secure installation of the unit.

Lack of observation of the details found within this manual, and an inadequate installation of the MINIAIR may cause the withdrawal of the warranty supplied with the equipment.

Furthermore, the Supplier will not respond to any eventual damage, whether direct or indirect, caused by the incorrect installation, or for damages caused by the installation being effectuated by inexperienced or unauthorised personnel.

Verify, upon acquisition, that the apparatus is complete and supplied as described.

Any eventual disputes must be presented in writing within 8 days from the reception of the goods.

1.2 Unit Identification

The MINIAIR Unit is provided with identification plate listing the following:

- Address of Constructor;
- "CE" Mark;
- Model;
- Serial Number;
- Maximum absorbed current "A";
- Power supply voltage "V";
- Power supply frequency "Hz";
- Number of phases "Ph";
- Date of fabrication;
- Unit Code.

SECTION 2 – TECHNICAL FEATURES

2.1 Unit Dimensions

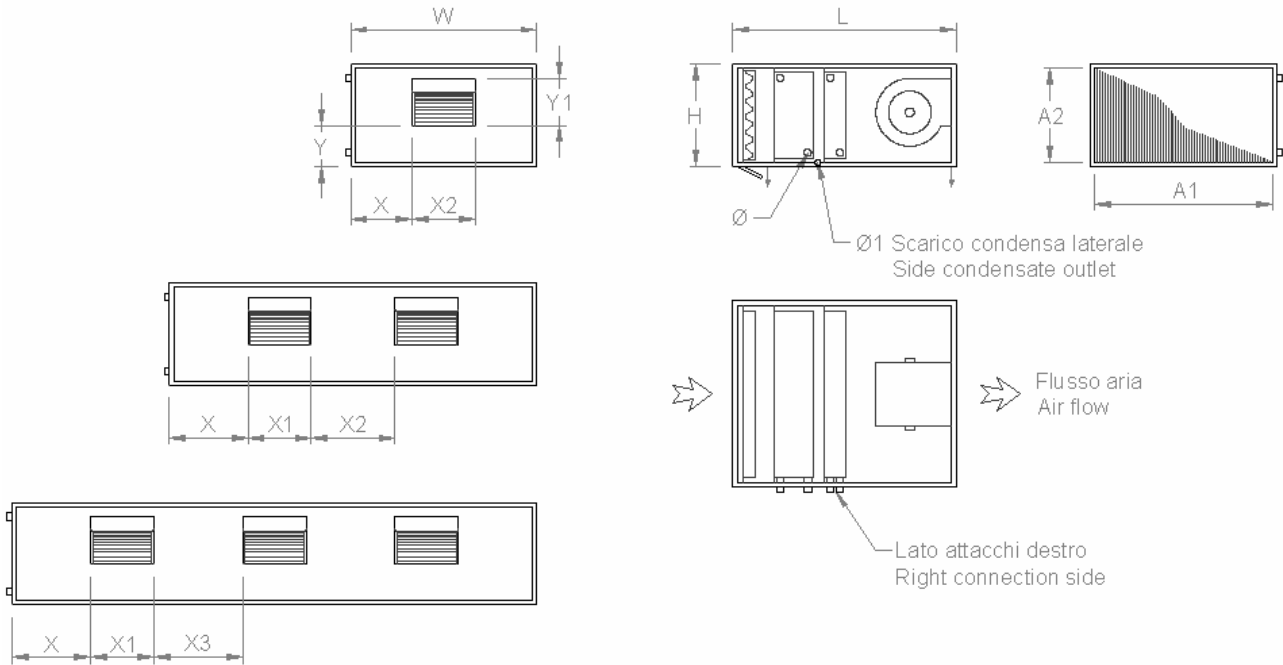

| Model | 10 | 20 | 25 | 30 | 40 | 50 | 60 |
|---------------|-------|-------|-------|-------|--------|---------|---------|
| 2) W | 710 | 1070 | 1400 | 1400 | 1680 | 1780 | 2000 |
| L | 390 | 390 | 390 | 390 | 390 | 480 | 480 |
| H | 850 | 850 | 850 | 850 | 850 | 960 | 960 |
| □ 2 R | ¾" | ¾" | ¾" | ¾" | ¾" | 1" | 1" |
| □ 4 R | ¾" | ¾" | 1" | 1" | 1" | 1 ¼" | 1 ¼" |
| □ 6 R | ¾" | 1" | 1" | 1" | 1 ¼" | 1 ¼" | 1 ¼" |
| □ 1 | 20 | 20 | 20 | 20 | 20 | 20 | 20 |
| X1 | 240 | 306 | 240 | 240 | 306 | 306 | 306 |
| 3) Y1 | 216 | 270 | 216 | 270 | 270 | 270 | 270 |
| X2 | - | - | 318 | 318 | 418 | 435 | - |
| X3 | - | - | - | - | - | - | 285 |
| A1 | 670 | 1030 | 1360 | 1360 | 1640 | 1720 | 1940 |
| A2 | 350 | 350 | 350 | 350 | 350 | 420 | 420 |
| X | 235 | 382 | 301 | 301 | 325 | 366 | 256 |
| Y | 136 | 82 | 136 | 82 | 82 | 160 | 160 |
| Weight | 52÷60 | 60÷70 | 75÷88 | 78÷90 | 96÷110 | 101÷120 | 120÷140 |

2.2 Unit technical data

| Model | | 10 | 20 | 25 | 30 | 40 | 50 | 60 |
|------------------------------|-------------------|--------------|-----------|-----------|-----------|-----------|-----------|-----------|
| Airflow rate | m ³ /h | 1040 | 2150 | 2740 | 3360 | 3950 | 5070 | 6450 |
| External static pressure (Δ) | Pa | 150 | 150 | 150 | 150 | 150 | 150 | 150 |
| 1 m sound pressure level | dB (A) | 52 | 55 | 55 | 57 | 58 | 57 | 59 |
| Motor power | W | 147 | 350 | 2 x 350 | 2 x 350 | 2 x 350 | 2 x 420 | 3 x 420 |
| Max. current | A | 1,9 | 3,0 | 2 x 3,0 | 2 x 3,0 | 2 x 3,0 | 2 x 3,8 | 3 x 3,8 |
| Fan speeds | | 3 | 3 | 3 | 3 | 3 | 3 | 3 |
| Protection grade | IP | 20 | 55 | 55 | 55 | 55 | 20 | 20 |
| Isolation Class | | B | F | F | F | F | B | B |
| Electrical power supply | V/ph/Hz | 230 / 1 / 50 | | | | | | |

| Model | | 10 | 20 | 25 | 30 | 40 | 50 | 60 |
|----------------------------------|--|-----------|-----------|-----------|-----------|-----------|-----------|-----------|
| N° G3 filter cells (356x293x48) | | 2 | 3 | 4 | 4 | 5 | 5 | 6 |
| N° F6 filter cells (356x293x320) | | 2 | 3 | 4 | 4 | 5 | 5 | 6 |

(Δ) 4 row coil version at nominal airflow rate

SECTION 3 – TRANSPORTATION



3.1 Packing

The MINIAIR units and their accessories are provided with adequate packing, that must stay intact until the moment of installing.

The materials that are not required for technical motives are supplied in fitted packing fixed externally and internally to the unit.

3.2 Transportation

For the lifting and transportation of the unit, use adequate equipment, according to the 89/391/CEE regulations and successive modifications.

Each individual machine weight is listed in this manual.

Avoid any uncontrolled rotation.

3.3 Checklist

Upon reception of the apparatus, we suggest that a complete control is carried out, to verify that the unit is intact and complete, and no damage has been sustained during transport. Any eventual damage revealed must be communicated to the carrier, demonstrating the reserve clause within the transport documents, specifying the type of damage.

3.4 Storing

In case of long term storage, the apparatus must be kept free from dust, and away from areas susceptible to heat and vibration.

The manufacturer declines any responsibility for any damage as a result of negligence or lack of protection from atmospheric agents.

SECTION 4 – INSTALLATION & CONNECTION



4.1 Definition

CLIENT– The client is the person, activity or the society, that has bought or hired the apparatus, and intends to utilise the machinery for its intended use.

USER / OPERATOR – The User or Operator, is the actual person that has been authorised by the client to utilise the apparatus.

TECHNICIAN – Defined as the person who has followed a relevant/specific course of study, and so is able to understand the dangers derived from the use of the apparatus, and in turn, due to this, are capable of solving major dilemmas.



4.2 Safety Regulations

The Manufacturer declines any responsibility for failure to respect the Safety Regulations, and the prevention as described below. Furthermore, the manufacturer declines any responsibility for damage caused by the improper use of the unit and/or modifications carried out without proper authorisation.

- **Qualified personnel must carry out the installation.**
- During the installation operation, use protective clothing, for example: glasses, gloves, etc. as indicated by 686/89/CEE and successive regulations.
- During the installation operate in absolute security, pollution free air and in an area free of obstructions.
- Respect the regulations in force in the country in which the apparatus is being installed. Specifically relative to its use, and to the disposal of packing and products used for the cleaning and maintenance of the unit. Respect the recommendations given by the producers of such products.
- Before placing in function the unit, check the perfect connection of the various components and the internal parts of the system.
- Avoid at all costs human contact with moving parts and contact with the parts themselves.
- **Do not commence with servicing or cleaning of the unit, before the unit has been disconnected from the main supply.**
- The maintenance and the substitution of damaged or consumed parts must be carried out only by specialised personnel, following the indications found within this manual.

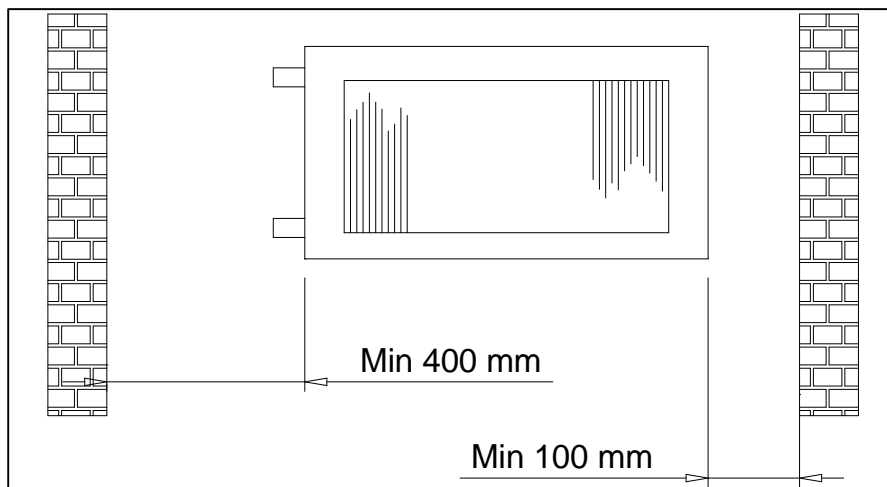

- Spare parts must correspond to the requirements specified by Manufacturer.
- In case of dismantling of the unit, respect the anti-pollution regulations in force.

N.B. The installer and the user of the apparatus must take into account, and solve problems, connected with any other type of risk that may occur to the unit. For example, risks derived from the entrance of foreign bodies, or risks due to the presence of flammable or toxic gas.

4.3 Preliminary Operations



- Check the perfect condition of the various components of the unit.
- Control that contained within the packing, there are the installation accessories, and documentation.
- Transport the packed section as close as is possible to the intended place of installation.
- Do not place tools or weight on top of the packed unit.

4.4 Choosing installation position



- Position the unit on a solid structure, that will not vibrate, and is capable supporting the weight of the machine.
- Position the unit in a point where the condensation discharge may occur easily.
- Do not position the unit in an area in which flammable gases, acidic or corrosive substances are present. They may damage various components in an irreparable manner.
- Allow a minimum amount of free space as indicated in the figure. This permits ease of installation and maintenance.

4.5 Connecting accessories



1. Fix the angular fixing clamp
2. Place together the fixing modules
3. Pass the M8 x 25 screws through the adjacent holes and necessary washers (see diagram)
4. Screw the nut by hand
5. Tighten with an Allen key

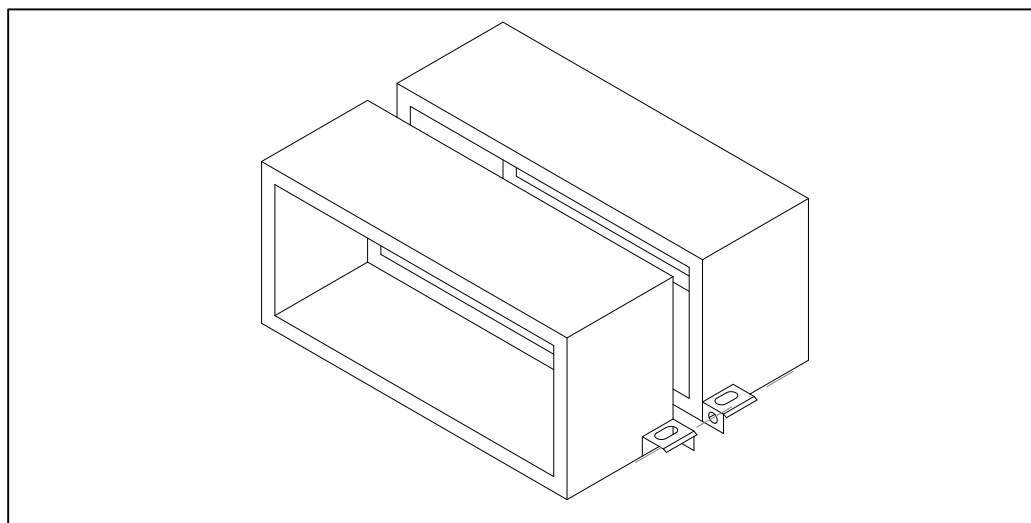

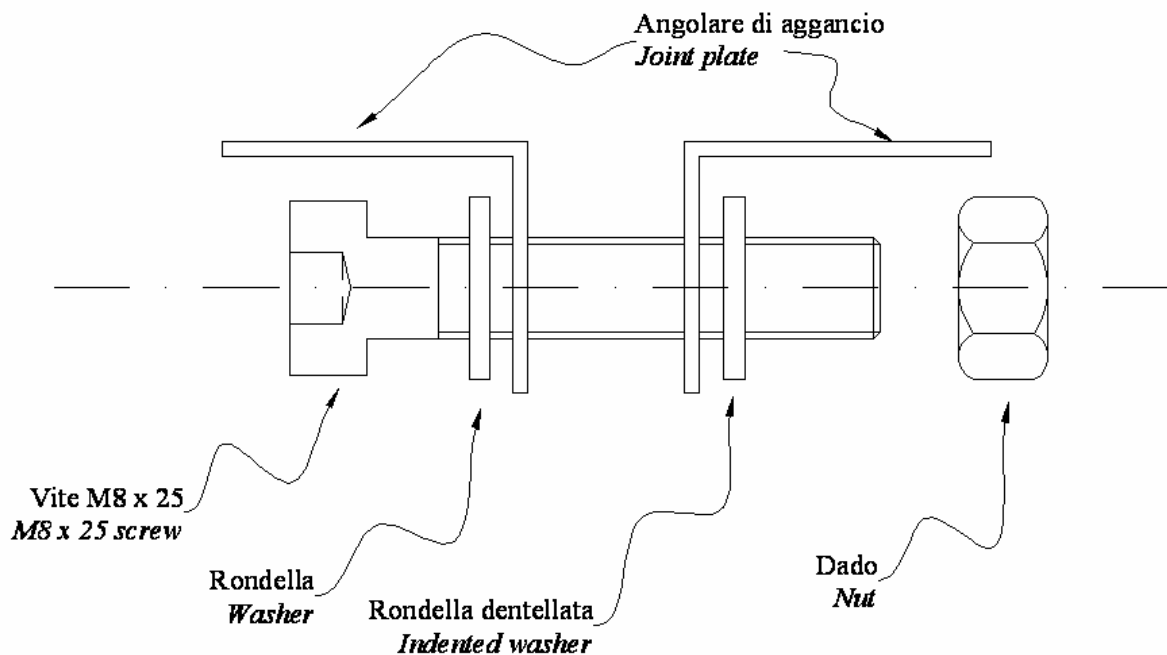

4.6 MINIAIR unit positioning

The unit is equipped with anti-vibration support plates.

As follows are indications the various sequence of assembly:

1. Carry out the drilling of the ceiling, and fit the four M8 threaded bolts as indicated in the diagram.
2. Position the unit on the four bolts using the supplied fixing plates.
3. Block the unit tightening the fixing bolts.

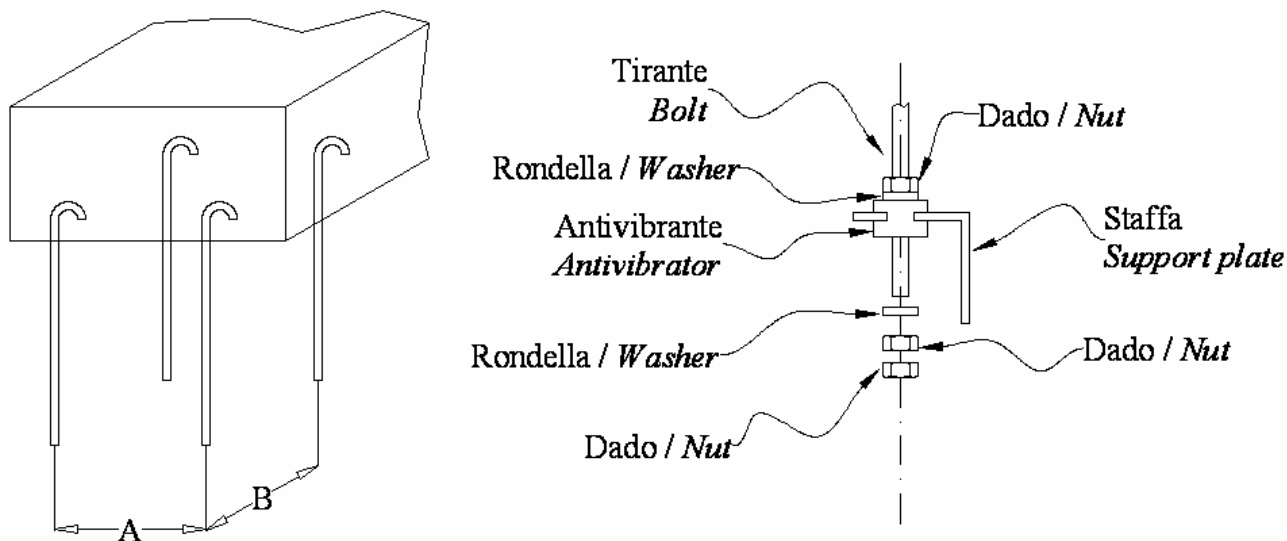

| <i>i. Dimensions</i> | 10 | 20 | 25 | 30 | 40 | 50 | 60 |
|----------------------|-----|------|------|------|------|------|------|
| A | 745 | 1105 | 1435 | 1435 | 1715 | 1820 | 2040 |
| B | 820 | 820 | 820 | 820 | 820 | 922 | 922 |

To aid the regular flow of the condensation, it is advised to install the unit with a 3mm inclination towards the condensation outlet.

4.7 Duct connection

IMPORTANT: IT IS IMPORTANT NOT TO PLACE IN OPERATION THE UNIT IF THE FAN OUTLETS ARE NOT DUCTED OR NOT PROTECTED BY A SAFETY NET ADHERING WITH REGULATION UNI 9219 OR SUCCESSIVE.

- The Ducts must be the correct dimension based on the functions of system and the air diffusion characteristics of the unit fans. A mistaken calculation of the ducting will cause power loss or the intervention of any eventual devices present on the system.
- To prevent the formation of condensation and cut down the sound level it is advised to use internally lined Ducts.
- To avoid the transmission of machine vibrations into the environment, it is advised to fit an anti-vibration joint between the fans and Ducts. The electrical continuity must be guaranteed between the Ducts and the apparatus via an earth cable.

4.8 Hydraulic connections

- The installation and connecting of the piping is an operation that must be done correctly, otherwise it may compromise the performance of the system. At worst it may cause irreversible damage to the machine. These operations are to be effectuated by **qualified personnel**.
- The MINIAIR units are supplied with “female” mounted, GAS threaded water coils.
- Extreme caution must be taken during the installation operation, to avoid damage.
- The tube path must be studied in such a way to not create obstacles should an eventual extraction of unit coil or filter be required.
- Water inlet and outlet must occur allowing the thermal exchange in counterflow: follow the indications found on the WATER INLET and WATER OUTLET plate.
- Supply a lower valve for the emptying of the water contained in the coil.
- Fix securely the tubes to the outside of the unit, so as to avoid offloading the weight onto the coil headers.
- Once the connection has been followed, fix the external rubber seals against the panel to avoid passing of air.
- The lining must just rest on the panel, to avoid the risk of burning.
- Supply an interception valve to isolate the coil from the rest of the circuit in case of extraordinary maintenance.
- Should the installation of the apparatus occur in areas with particularly cold climates, empty the system prior to an extended period of inutilization.

4.8.1 Condensation outlet connection

- The stainless steel condensation drip tray is provided with 20 mm outlet diameter.
- The system of drainage must provide an adequate trap.
- The dimensions and execution of the trap must guarantee that $H \geq 50$ mm.

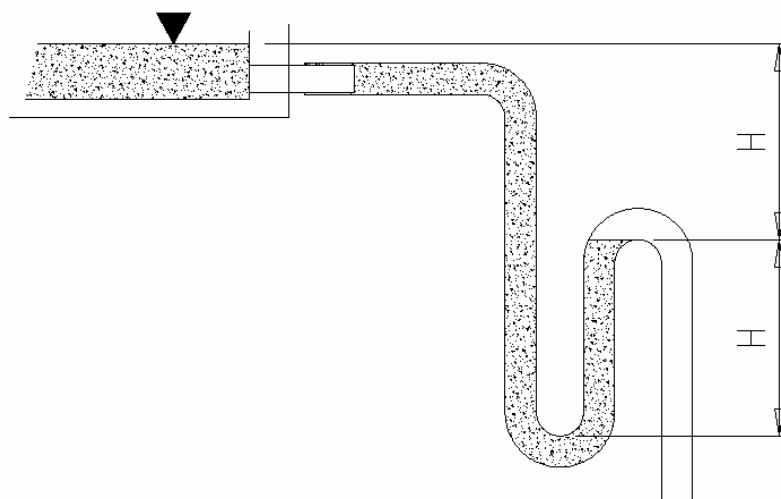

- The trap must have a tap for correct cleaning of the lower part, and must allow an easy disassembly.
- The path of the condensation drainage tube must always have a gradient toward external.
- Insure that the condensation run-off tube does not interfere with discharge of the unit.

4.8.2 Water humidifier connection

The evaporative pack section is feded by water public network (no water pump inside); the feeding system must provide a valve (supplied by the installer) for the adjustment of the water flow; an excessive quantity may overflow the driptray system present in the system.

For the drainage of the water and the realisation of the trap, see previous paragraph; furthermore it is recommended to not reduce the diameter of the drainage tube till the sewer outlet, so as to avoid overflow and nasty odours.

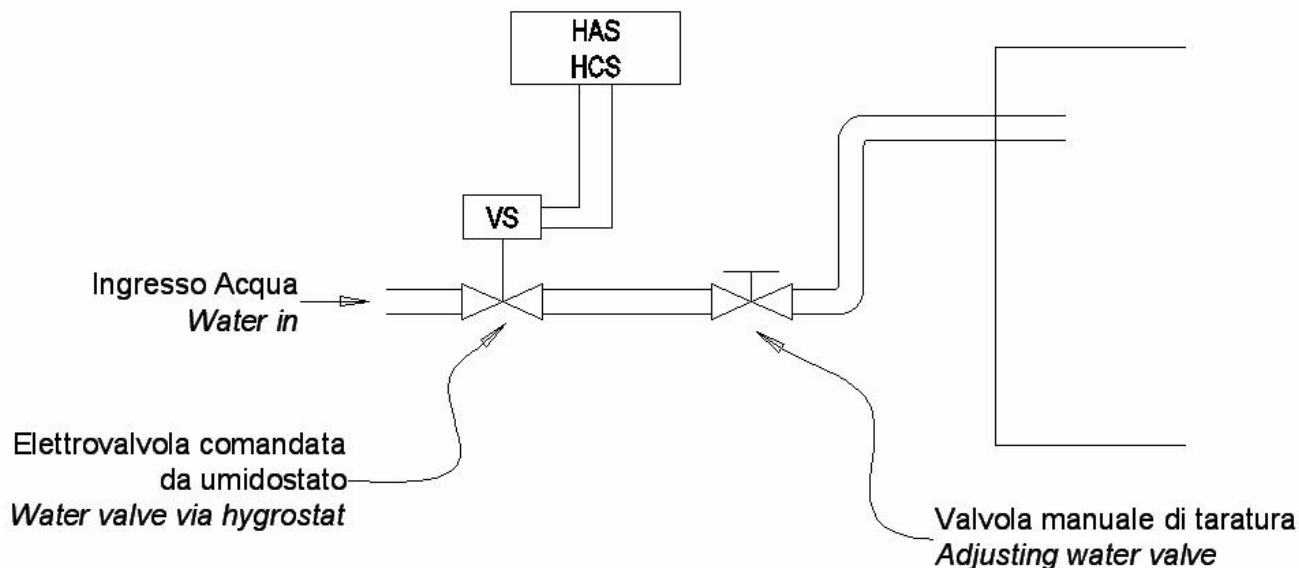

4.9 Electrical connections



Before starting any operation, insure that the general power supply has been switched off.

- Qualified personnel according to the supplied schemes must carry out the electrical connections at the control panel.
- Insure that the voltage and the frequency shown on the technical plate correspond to the connecting power supply.

Connect the unit and its accessories using adequate wiring for the used power while respecting the country regulations. The dimension of the wiring must be enough to support a voltage drop in start up phase lower than 3% of the nominal one.

- For the general power supply of the unit and its accessories, the use of adapters, multiple plugs and extension leads is to be avoided.
- **It is the responsibility of the installer to insure that the installation of the unit is as close as possible to the mains power supply, or sufficiently close to protect the electrical parts.**
- Connect the unit to an efficient power point, using the correct screws as supplied with the unit.

The electrical wiring diagrams of the ordered unit are supplied with it when delivered and they are related to the real accessory selection.

SECTION 5 – PRE START CHECKLIST

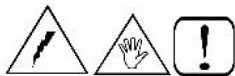

5.1 Checks prior to Start-up

Before turning on the apparatus verify the following:

- Fixing of unit to ceiling;
- Connection of ducts;
- Correct condensation run-off;
- Connection of mains supply;
- Closing of all electrical clamps.

SECTION 6 – STANDARD MAINTENANCE



BEFORE FOLLOWING ANY TYPE OF MAINTENANCE OPERATION, BE CERTAIN THAT THE APPARATUS MAY NOT CASUALLY OR ACCIDENTALLY BE CONNECTED TO THE ELECTRICAL MAINS SUPPLY. THEREFORE IT IS NECESSARY TO SHUTDOWN THE UNIT'S POWER SUPPLYAD PRIOR TO MAINTENANCE.

- It is the responsibility of the user to carry out all types of maintenance operations.
- Only personnel previously trained and qualified may carry out maintenance operations.
- Should the apparatus require disassembly, hand protection is required



6.1 Monthly maintenance

6.1.1 Filter section check

If the filter is dirty, open the lower panel door, remove the screws as seen in figure 1, remove filter door and remove the filter from below (figure 2). For cleaning, utilise a vacuum cleaner or wash with normal detergent in warm water, dry well. Remember to always fit the filter before re-starting the apparatus.

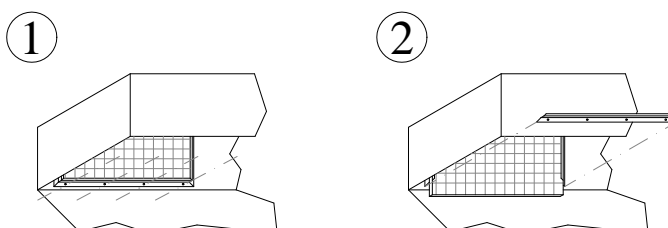

6.1.2 Bag filter section check

The soft bag filters are high performance type and require periodical checking, as a marked deterioration may occur during usage, especially at the point where they are attached to the main frame. This is due to the continuous deformation, and for the weight of the dust caught.

These filters are not recyclable, and any cleaning may only be carried a few times by turning the filter upside down.

Should it become necessary to substitute the filters, verify the condition of the sealing, and proceed with the substitution.

The bags full of dust must be removed with great care, or to achieve a safer operation, cover the air inlet area. This will avoid the over-spill of dust inside the apparatus.

6.1.3 Coil check

Check that the Coil exchanger is clean and in a perfect condition so as to guarantee correct performance.

6.1.4 Water humidifier section check

A periodical cleaning of the drip tray is recommended by using steam (high pressure or similar) or specific cleaning products. Alternatively, replace the evaporation pack, efficient working of which is fundamental to guarantee the air quality.

The pack must be replaced when limestone build-up is found.

The evaporative pack must be fitted in its correct position, controlling the air direction through the apparatus and the water flow on the filter.

Always check the cleaning and the efficiency of the outlet and the inlet of the water section.

6.1.5 Power supply check

Control that the power supply voltage falls within the prescribed limits.

6.2 Yearly maintenance

Check that all the electrical equipment, in particular the fixing of the electrical connections.

Check the tightness of all nuts, bolts, flanges and hydraulic connections that the vibrations of the machine may have loosened.

SECTION 7 – TROUBLESHOOTING



7.1 Finding faults

| ANOMALY | POSSIBLE CAUSE |
|--|---|
| The motor does not run | <ul style="list-style-type: none">• Power supply not present• The thermostat switches are not in their exact functioning position• Material/foreign bodies blocking moving parts• Loose electrical connections |
| Loss of performance after a period of satisfactory working | <ul style="list-style-type: none">• The filter and coil are dirty• The system is not correctly balanced• Air present in hydraulic system. Release with specific valve.• Obstruction present in ducts |

SECTION 8 – SPARE PARTS



8.1 Spare part order

In the following table there are the codes of the unit components that might be replaced; the Customer must refer to these codes for the possible spare part order. See 2.2 paragraph for the used quantity in the specific model.

| ii. Spare part | Model | | | | | | |
|-------------------|------------|------------|----------|------------|------------|----------|----------|
| | 10 | 20 | 25 | 30 | 40 | 50 | 60 |
| Direct driven fan | 03305021 | AMF0000097 | 03305028 | AMF0000040 | AMF0000097 | 03305063 | 03305063 |
| 2-row water coil | 03420192 | 03420193 | 03420105 | 03420105 | 03420106 | 03420199 | 03420202 |
| 4-row water coil | 03420169 | 03420170 | 03420100 | 03420100 | 03420171 | 03420198 | 03420201 |
| 6-row water coil | 03420194 | 03420195 | 03420102 | 03420102 | 03420196 | 03420150 | 03420200 |
| G3 filter | AMF0002466 | | | | | | |
| F6 bag filter | AMF0001743 | | | | | | |

SECTION 9 – MATERIAL DISPOSAL



9.1 Material disposal

At the end of the productive life cycle, the MINIAIR Unit must be dismantled and disposed of respecting the operational regulations present in its country of installation.

The materials that the unit is constructed of are:

- Aluzink sheet metal;
- Zinc-plated sheet metal;
- Aluminium;
- Copper;
- Polyester;
- Polyethylene;
- Inox Stainless Steel;
- Plastic.

18.2

MINIAIR+

SECTION 10 – PRESENTATION

10.1 Manual presentation

This instruction manual supplies the necessary information for the transportation, the installation, operation and maintenance of the **MINIAIR+** apparatus as supplied by the company LENNOX (from this point named as the supplier). It supplies the user with as much information as is normally useful for a correct and secure installation of the unit.

Lack of observation of the details found within this manual, and an inadequate installation of the MINIAIR+ may cause the withdrawal of the warranty supplied with the equipment.

Furthermore, the Supplier will not respond to any eventual damage, whether direct or indirect, caused by the incorrect installation, or for damages caused by the installation being effectuated by inexperienced or unauthorised personnel.

Verify, upon acquisition, that the apparatus is complete and supplied as described.

Any eventual disputes must be presented in writing within 8 days from the reception of the goods.

10.2 Machine identification

The MINIAIR+ Unit is provided with identification plate listing the following:

- Address of Constructor
- “CE” Mark
- Model
- Serial Number
- Maximum Current absorbed in “A”
- Power supply voltage in “V”
- Power supply frequency in “Hz”
- Number of phases indicated with “Ph”
- Date of fabrication
- Gross weight in “Kg”

SECTION 11 – TECHNICAL CHARACTERISTICS

11.1 General characteristics

- Completely removable aluzink plate side panels.
- Panel thermal and acoustic insulation by means of polyethylene/polyester panels with a medium thickness of 20 mm.
- High efficiency aluminium plate static type heat recuperators, with air flows separated by special seals.
- UE3 efficiency air filters, which may be easily removed from the sides allowing their periodic cleaning.
- Fan bodies mounted on anti-vibrators.
- Double inlet centrifugal fans (for MINIAIR+03 single inlet fans) which may be removed from the sides for periodic maintenance.
- Multi-speed directly coupled electric motors..
- To aid the electrical connections and ventilator control, a terminal block with a relay board is fitted.
- Stainless steel condensation collecting tray, with condensation drainage towards the lower part

11.2 Accessories

- Electrical reheating **SKE**
- Water coil for reheating **SKW**
- Regulation damper **SKR**
- Speed selector **CVU**
- Apparatus Control Panel **PCU**
- Pressure operated soiled filter cut-off switch **PSTD**
- Servomotor for damper regulations **SSE**
- Anti-freeze thermostat **TEG**

11.3 Packing dimensions

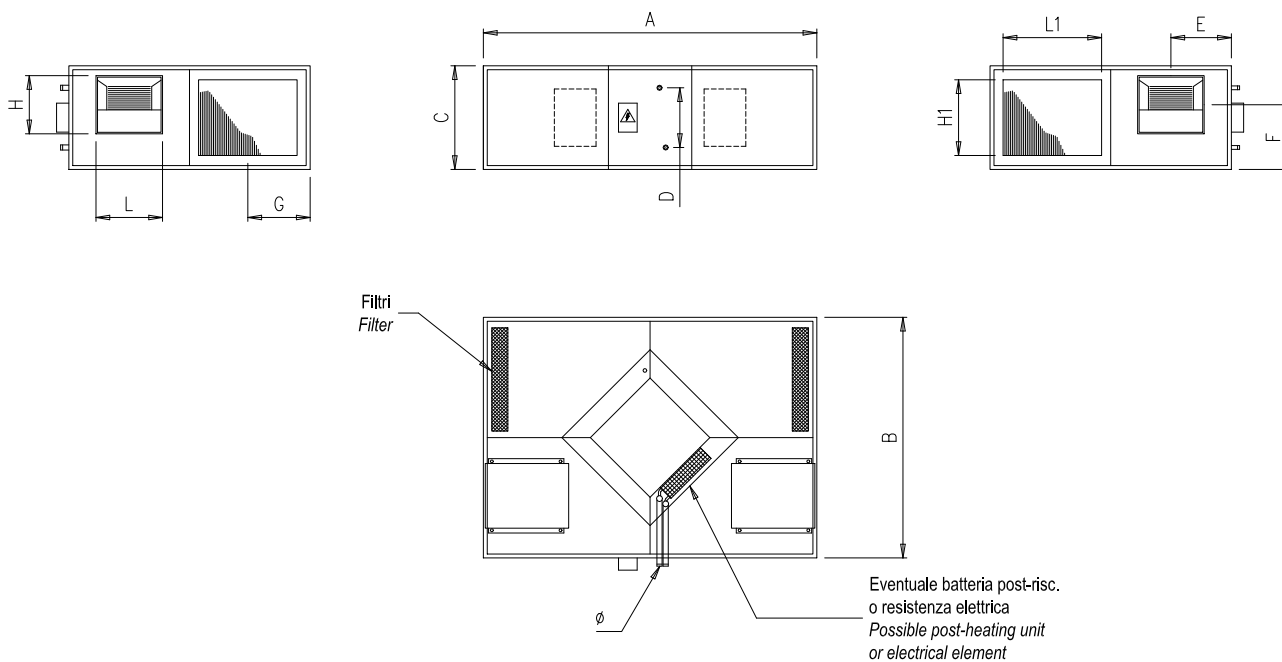

| Model | 03 | 06 | 10 | 14 | 19 | 25 | 30 | 40 |
|---------|-----|-----|-----------------|-----------------|-----------------|-----------------|-----------------|-----------------|
| A (mm) | 990 | 990 | 1150 | 1350 | 1450 | 1700 | 1700 | 1700 |
| B (mm) | 750 | 750 | 860 | 900 | 900 | 1230 | 1230 | 1230 |
| C (mm) | 270 | 270 | 385 | 410 | 470 | 490 | 530 | 630 |
| L (mm) | 127 | 164 | 240 | 240 | 240 | 306 | 339 | 339 |
| H (mm) | 112 | 100 | 218 | 270 | 270 | 270 | 297 | 297 |
| L1 (mm) | 275 | 275 | 330 | 337 | 337 | 502 | 502 | 502 |
| H1 (mm) | 153 | 153 | 267 | 267 | 327 | 347 | 387 | 487 |
| D (mm) | - | - | 230 | 230 | 280 | 305 | 305 | 405 |
| E (mm) | 120 | 197 | 225 | 241 | 230 | 323 | 308 | 308 |
| F (mm) | 135 | 171 | 238 | 224 | 284 | 304 | 331 | 431 |
| G (mm) | 195 | 195 | 222 | 239 | 239 | 321 | 321 | 321 |
| ϕ | - | - | G $\frac{3}{4}$ | G $\frac{3}{4}$ | G $\frac{3}{4}$ | G $\frac{3}{4}$ | G $\frac{3}{4}$ | G $\frac{3}{4}$ |

11.4 Unit technical data

| Model | | MINIAIR+ 03 | MINIAIR+ 06 | MINIAIR+ 10 | MINIAIR+ 14 | MINIAIR+ 19 | MINIAIR+ 25 | MINIAIR+ 30 | MINIAIR+ 40 |
|---------------------------|-------------------|-------------|-------------|-------------|-------------|-------------|-------------|-------------|-------------|
| Air flow | m ³ /h | 290 | 550 | 1000 | 1400 | 1900 | 2500 | 3200 | 4000 |
| Available static pressure | Pa | 60 | 65 | 90 | 140 | 120 | 110 | 170 | 170 |
| Liv. Sound pressure | dB (A) | 53 | 54 | 54 | 59.5 | 58 | 57,5 | 60,5 | 62 |

| Fans | | MINIAIR+ 03 | MINIAIR+ 06 | MINIAIR+ 10 | MINIAIR+ 14 | MINIAIR+ 19 | MINIAIR+ 25 | MINIAIR+ 30 | Section 1.0 MINIAIR+ 40 | |
|------------------|---------|--------------|-------------|-------------|-------------|-------------|-------------|-------------|----------------------------|--|
| Absorbed power | W | 2 x 45 | 2 x 65 | 2x 147 | 2x 350 | 2x 350 | 2x 350 | 2x 550 | 2x 750 | |
| Poles | n° | 4 | 2 | 4 | 4 | 4 | 4 | 4 | 4 | |
| Max current | A | 1,32 | 1,6 | 3 | 5,8 | 6,2 | 6 | 11,4 | 6,2 | |
| N° fan speed | | 2 | 2 | 3 | 3 | 3 | 3 | 3 | 2 | |
| Protection | | 20 | 44 | 44 | 55 | 44 | 55 | 20 | 55 | |
| Insulation Class | | B | F | F | F | F | F | F | F | |
| Power supply | V/ph/Hz | 230 / 1 / 50 | | | | | | | 400/3/50 | |

| Thermal recuperator (*) | | MINIAIR+ 03 | MINIAIR+ 06 | MINIAIR+ 10 | MINIAIR+ 14 | MINIAIR+ 19 | MINIAIR+ 25 | MINIAIR+ 30 | MINIAIR+ 40 |
|-------------------------|----|-------------|-------------|-------------|-------------|-------------|-------------|-------------|-------------|
| Efficiency | % | 52,3 | 54,6 | 53,4 | 52,1 | 51,8 | 57,6 | 56 | 55,6 |
| Capacity recovered | kW | 1,34 | 2,57 | 4,6 | 6,2 | 8,4 | 12,3 | 15,3 | 19,4 |
| Outlet temp | °C | 8,1 | 8,7 | 8,3 | 8,0 | 7,9 | 9,4 | 9,0 | 8,9 |

| Filters(*) | | MINIAIR+ 03 | MINIAIR+ 06 | MINIAIR+ 10 | MINIAIR+ 14 | MINIAIR+ 19 | MINIAIR+ 25 | MINIAIR+ 30 | MINIAIR+ 40 |
|-------------------|-----|-------------|-------------|-------------|-------------|-------------|-------------|-------------|-------------|
| Efficiency | | G3 | G3 | G3 | G3 | G3 | G3 | G3 | G3 |
| Frontal air speed | m/s | 1,7 | 3,6 | 2,9 | 4,1 | 4,5 | 3,8 | 4,3 | 4,3 |
| Size | mm | 300 | 300 | 356 | 356 | 363 | 528 | 528 | 628 |
| | | 178 | 178 | 293 | 293 | 353 | 373 | 413 | 413 |
| | | 48 | 48 | 48 | 48 | 48 | 48 | 48 | 48 |

(*) Size valued in the following hypothesis: T_{ing}. External = -5°C; T_{ambient} 20°C ; nominal air flow.

11.5 Accessories technical data

11.5.1 Water coil for reheating

| Section 1.03 Coil code | | SKW 10 | SKW 14 | SKW 19 | SKW 25 | SKW 30 | SKW 40 |
|-------------------------------|-----|---------------|---------------|---------------|---------------|---------------|---------------|
| Geometry | | 25 22 | 25 22 | 25 22 | 25 22 | 25 22 | 25 22 |
| Tubes per row | N ° | 14 | 14 | 16 | 17 | 17 | 21 |
| Rows | N ° | 3 | 3 | 3 | 3 | 3 | 3 |
| Fin pitch | mm | 2.5 | 2.5 | 2.5 | 2.5 | 2.5 | 2.5 |
| Capacity | KW | 9.4 | 13.4 | 16.6 | 23.9 | 28.4 | 36.2 |
| Outlet temp | ° C | 36 | 36.6 | 34.1 | 36.6 | 34.5 | 34.3 |
| Air pressure drop | Pa | 65 | 64 | 85 | 62 | 85 | 92 |
| Water pressure drop | kPa | 8 | 16 | 10 | 11 | 15 | 27 |

Size valued in the following hypothesis:
 Water 70/60°C;
 Air entrance temperature 8°C;
 Nominal air volume.

11.5.2 Electrical reheating

| Coil code | | SKE 03 | SKE 06 | SKE 10 | SKE 14 | SKE 19 | SKE 25 | SKE 30 | SKE 40 |
|-------------------------|----|---------------|---------------|---------------|---------------|---------------|---------------|---------------|---------------|
| Electrical coil 1 stage | kW | 2 | 4 | 4.5 | 6 | 9 | 12 | 12 | 12 |
| Power supply | V | 230 | 230 | 400 | 400 | 400 | 400 | 400 | 400 |
| Phases | n° | 1 | 1 | 3 | 3 | 3 | 3 | 3 | 3 |
| Stage | n° | 1 | 1 | 1 | 1 | 1 | 1 | 1 | 1 |
| Absorbed current | A | 8.7 | 17.4 | 6.5 | 8.7 | 13 | 17.3 | 17.3 | 17.3 |
| Outlet Air Temp (+) | °C | 28.4 | 27.8 | 21.3 | 20.7 | 22 | 22.2 | 19.5 | 17 |

(+) Size valued with Ting air = 8°C and nominal air capacity.

11.6 Possible positioning

For each size available, four possible positions for the recuperators are available. Depending on the net configuration, and available space, one of the four possibilities below may be employed

11.6.1 Horizontal unit orientation

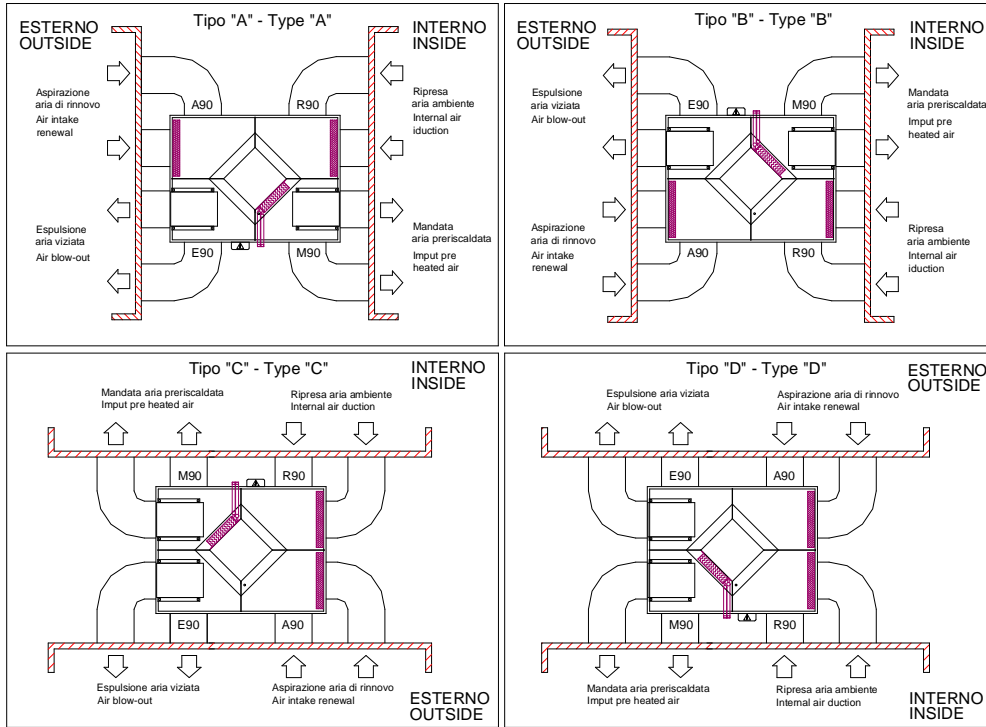

11.6.2 Vertical unit orientation

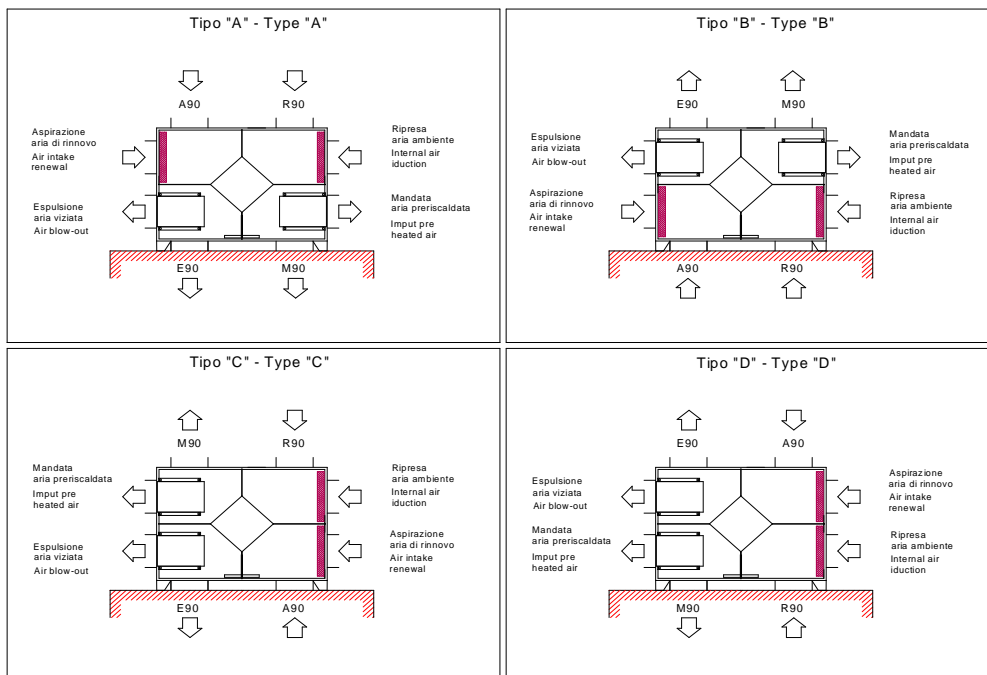

11.6.3 Vertical unit with post-heating coil

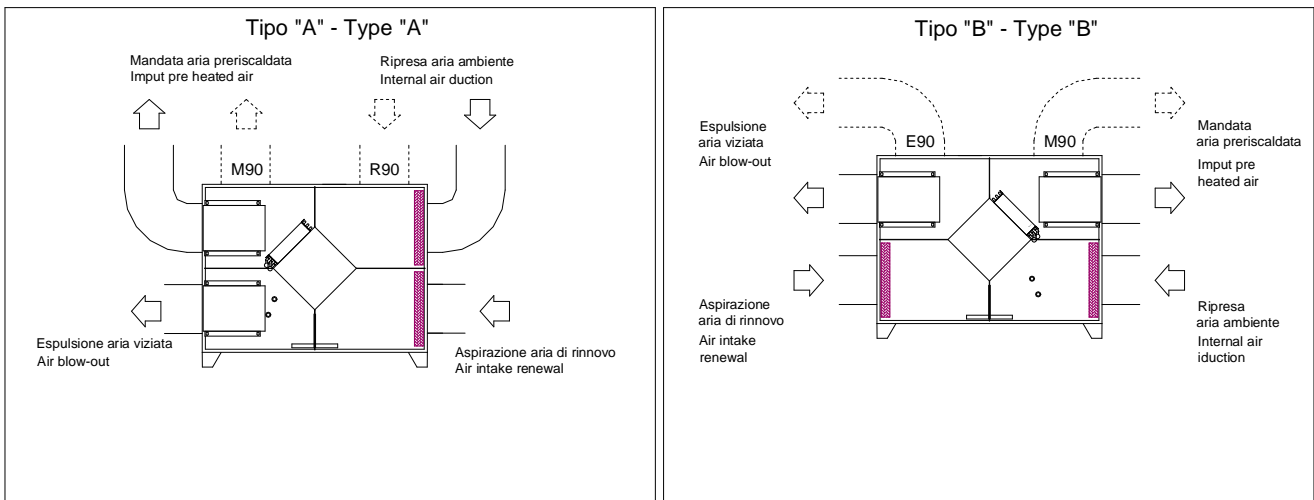

As shown in the figure below, by simply changing the position of two panels it is possible to suck or blow out air from the sides instead from the front of the unit

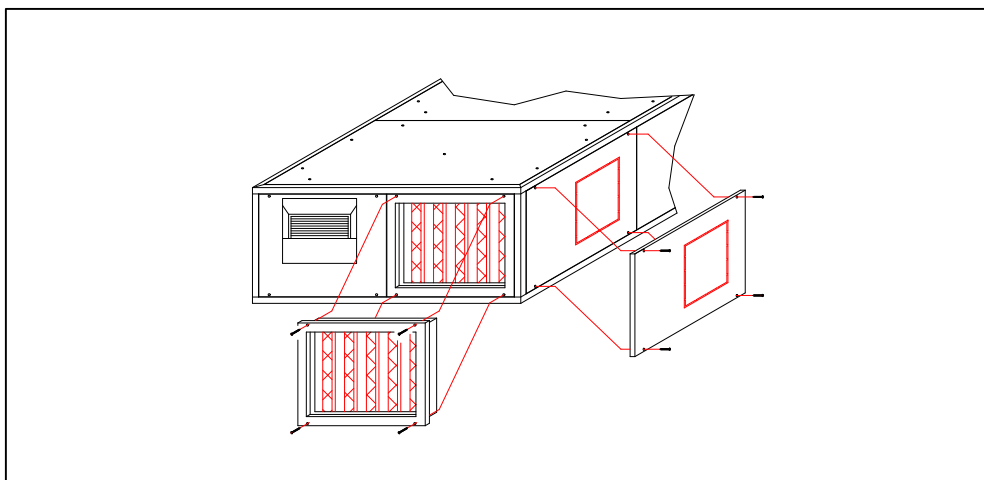

11.7 By-pass for de-frosting or free-cooling

For MINIAIR+ 03-06-10-14-19-25-30 models the structure has a presplitting allowing defrosting by-pass or free cooling to be carried out.

Free cooling. When the external temperature is close to the internal temperature the recuperator may be bypassed inserting renewal air directly in the room.

It is possible to do this by opening damper B and at the same time closing damper A.

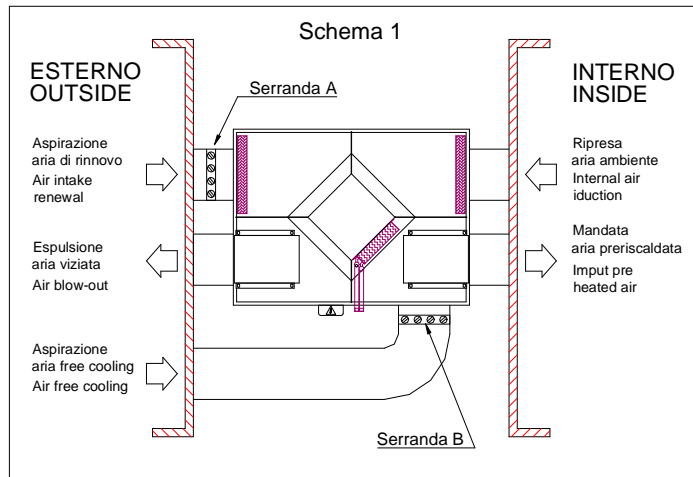

Defrosting. In very cold periods the room delivery air could frost blocking the passage through the recuperator. Installing an antifreeze thermostat (optional) combined with the bypass system indicated in the figure unit defrosting is obtained. In fact opening gate A and closing gate B the recuperator is bypassed with cold air and the flow of hot air coming from the room air delivery allows a rapid defrosting of the recuperator itself which can therefore return to operation in normal conditions.

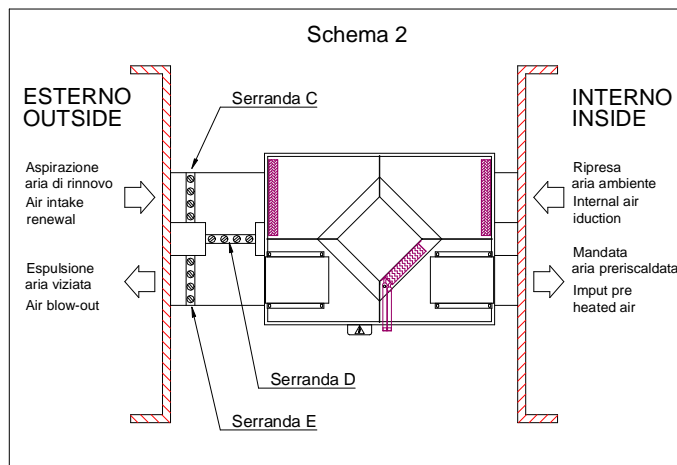

SECTION 12 – TRANSPORTATION



12.1 Packing

The recuperators are placed in carton boxes that must remain intact until the moment of installation. The materials that are not required for technical motives are supplied in fitted packing fixed externally and internally to the unit.

12.2 Transportation

For the lifting and transportation of the unit, use adequate equipment, according to the 89/391/CEE regulations and successive modifications.

Each individual machine weight is listed in this manual.

Avoid rotation without control.

12.3 Checklist

Upon reception of the apparatus, we suggest that a complete control is carried out, to verify that the unit is intact and complete, and no damage has been sustained during transport. Any eventual damage revealed must be communicated to the carrier, demonstrating the reserve clause within the transport documents, specifying the type of damage.

12.4 Storing

In case of long term storage, the apparatus must be kept free from dust, and away from areas susceptible to heat and vibration.

The manufacturer declines any responsibility for any damage as a result of negligence or lack of protection from atmospheric agents.

SECTION 13 – INSTALLATION & CONNECTION



13.1 Definition

CLIENT– The client is the person, activity or the society, that has bought or hired the apparatus, and intends to utilise the machinery for its intended use.

USER / OPERATOR – The User or Operator, is the actual person that has been authorised by the client to utilise the apparatus.

TECHNICIAN – Defined as the person who has followed a relevant/specific course of study, and so is able to understand the dangers derived from the use of the apparatus, and in turn, due to this, are capable of solving major dilemmas.



13.2 Safety regulations

The Manufacturer declines any responsibility for failure to respect the Safety Regulations, and the prevention as described below. Furthermore, the manufacturer declines any responsibility for damage caused by the improper use of the unit and/or modifications carried out without proper authorisation.

- **Qualified personnel must carry out the installation.**
- During the installation operation, use protective clothing, for example: glasses, gloves, etc. as indicated by 686/89/CEE and successive regulations.
- During the installation operate in absolute security, pollution free air and in an area free of obstructions.
- Respect the regulations in force in the country in which the apparatus is being installed. Specifically relative to its use, and to the disposal of packing and products used for the cleaning and maintenance of the unit. Respect the recommendations given by the producers of such products.
- Before placing in function the unit, check the perfect connection of the various components and the internal parts of the system.
- Avoid at all costs human contact with moving parts and contact with the parts themselves.
- **Do not commence with servicing or cleaning of the unit, before the unit has been disconnected from the main supply.**

- The maintenance and the substitution of damaged or consumed parts must be carried out only by specialised personnel, following the indications found within this manual.
- Spare parts must correspond to the requirements specified by Manufacturer.
- In case of dismantling of the unit, respect the anti-pollution regulations in force.

N.B. The installer and the user of the apparatus must take into account, and solve problems, connected with any other type of risk that may occur to the unit. For example, risks derived from the entrance of foreign bodies, or risks due to the presence of flammable or toxic gas.

13.3 Preliminary operations



- Check the perfect condition of the various components of the unit.
- Control that contained within the packing, there are the installation accessories, and documentation.
- Transport the packed section as close as is possible to the intended place of installation.
- Do not place tools or weight on top of the packed unit.

13.4 Choosing place of installation



- Position the unit on a solid structure, that will not vibrate, and is capable supporting the weight of the machine.
- Position the unit in a point where the condensation discharge may occur easily.
- Do not position the unit in an area in which flammable gases, acidic or corrosive substances are present. They may damage various components in an irreparable manner.
- Allow a minimum amount of free space as indicated in the figure. This permits ease of installation and maintenance.

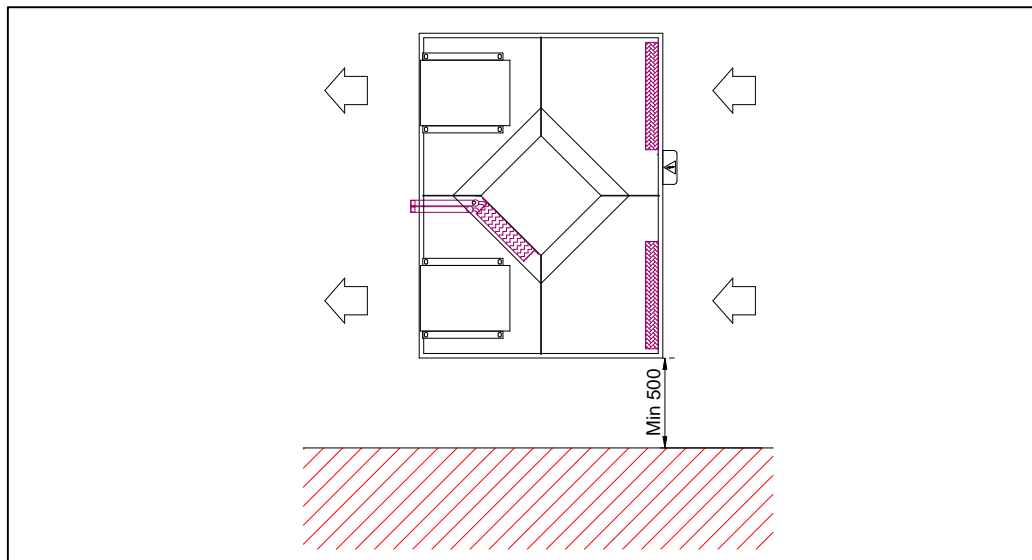

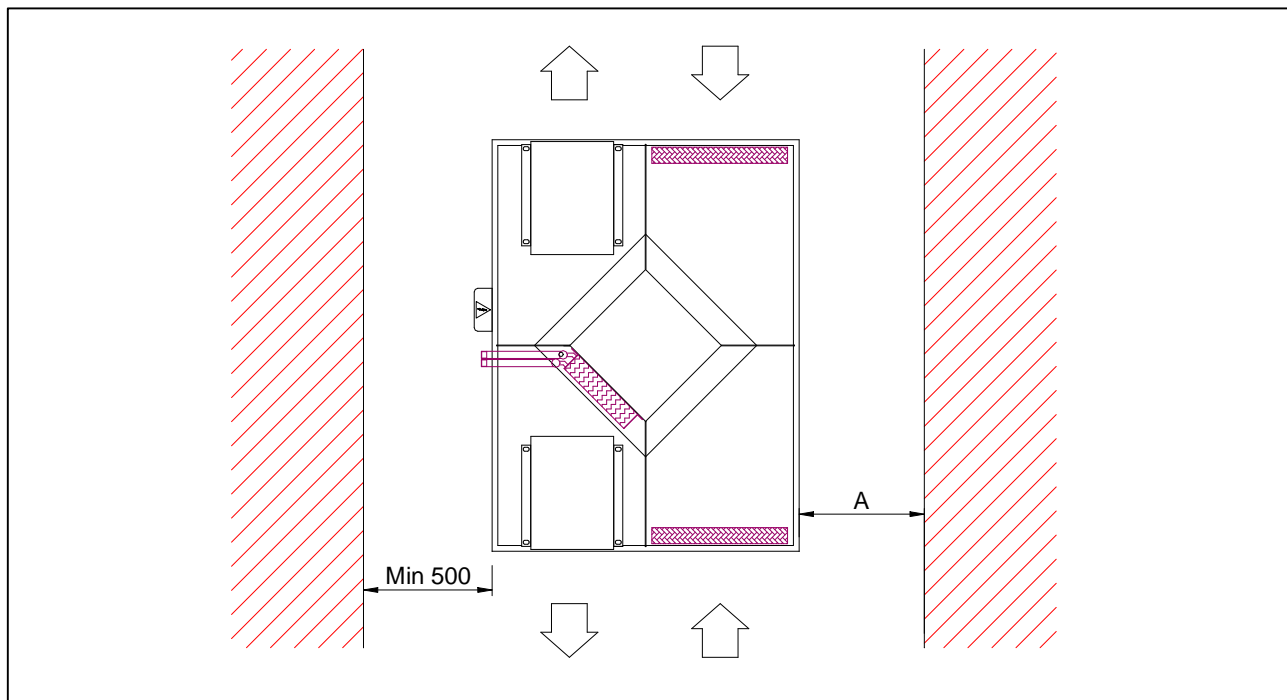

| Model | 03 | 06 | 10 | 14 | 19 | 25 | 30 |
|----------------|-----|-----|-----|-----|-----|-----|-----|
| Section 1.04 A | 300 | 300 | 350 | 400 | 400 | 450 | 450 |

13.5 Machine positioning

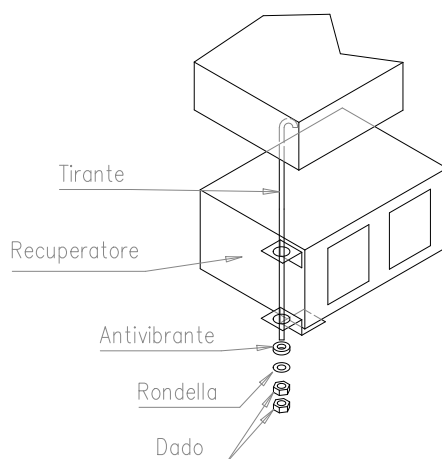

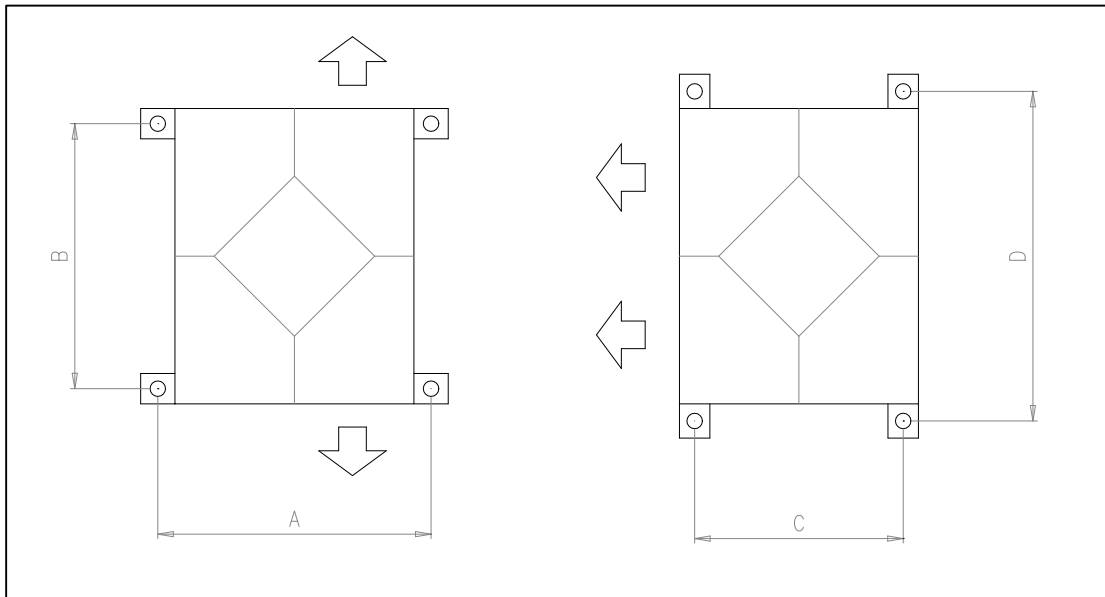

| Model | 03 | 06 | 10 | 14 | 19 | 25 | 30 |
|-----------------------|------|------|------|------|------|------|------|
| Section 1.05 A | 796 | 796 | 906 | 946 | 946 | 1276 | 1276 |
| B | 940 | 940 | 1100 | 1230 | 1380 | 1630 | 1630 |
| C | 700 | 700 | 810 | 830 | 830 | 1160 | 1160 |
| D | 1036 | 1036 | 1196 | 1346 | 1496 | 1746 | 1746 |

To aid the regular flow of the condensation, it is advised to install the apparatus with a 3 mm inclination towards the condensation outlet.

13.6 Duct connection



IMPORTANT: IT IS IMPORTANT NOT TO PLACE IN OPERATION THE UNIT MINIAIR+ IF THE MOUTHS OF THE FANS ARE NOT DUCTED OR NOT PROTECTED BY A SAFETY NET ADHERING WITH REGULATION UNI 9219 OR SUCCESSIVE.

- The Ducts must be the correct dimension based on the functions of system and the air diffusion characteristics of the unit fans. A mistaken calculation of the ducting will cause power loss or the intervention of any eventual devices present on the system.
- To prevent the formation of condensation and cut down the sound level it is advised to use internally lined Ducts.
- To avoid the transmission of machine vibrations into the environment, it is advised to fit an anti-vibration joint between the fans and Ducts. The electrical continuity must be guaranteed between the Ducts and the apparatus via an earth cable.

13.7 Hydraulic connections

The installation and connecting of the piping is an operation that must be done correctly, otherwise it may compromise the performance of the system. At worst it may cause irreversible damage to the machine. These operations are to be effectuated by **qualified personnel**.

13.7.1 Condensation outlet connection

- The condensation drip tray in stainless steel inox has a depth of D. 12 mm.
- The system of drainage must provide an adequate trap to prevent the undesirable entrance of air into the system in depression. The trap is also useful to avoid the infiltration of odours and insects.
- The dimensions and execution of the trap must guarantee that $H \geq P$, where P is expressed in mm.c.a, and is equal to the useful static pressure of the unit installed.

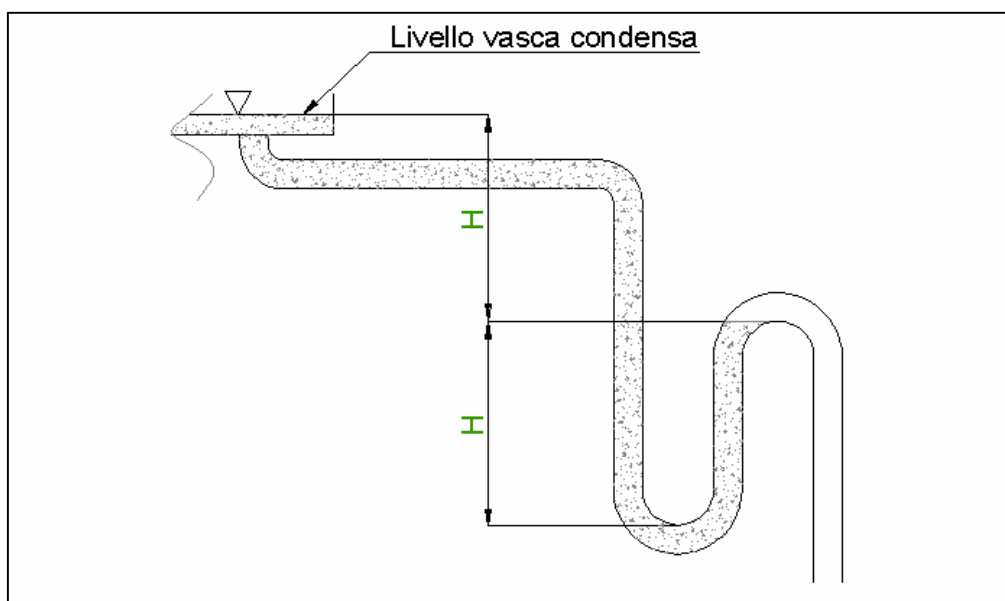

- The trap must have a tap for correct cleaning of the lower part, and must allow an easy disassembly.
- The path of the condensation drainage tube must always have a gradient toward external.
- Insure that the condensation run-off tube does not interfere with discharge of the unit.

13.7.2 Eventual connection for SKW water reheating coil

- The eventual water reheating coil is supplied with “male” connections with gas threads.
- The tightening must be carried out with extreme care to avoid damage to the copper collectors of the coil.
- The path of the tubes must be studied in a way to avoid obstacles should it be necessary to extract the unit coil.
- Inlet and outlet water must consent the thermal exchange against the current. Follow instructions found on the WATER INLET and WATER OUTLET plate.
- Provide an escape valve at the top of the unit, and a discharge valve at the bottom.
- Reinforce sufficiently the units external tubes to avoid offloading the weight onto the coil.
- Once connection has been effectuated, fix the external seal flush against the control panel, in this way avoiding the passing of air.
- La insulation must not rest against the panelling, as this may provoke burning.
- For control purposes, organize the interception of the tube side coil when the fan is off, to avoid internal overheating and possible damage to internal components.
- Provide an anti-freeze system.
- Provide a cut out switch to isolate the coil from the rest of the circuit in case of extensive maintenance needs.
- Should the unit be installed in particularly cold areas, drain completely before long periods of in-operation.

13.8 Electrical connections



Before commencing any operation, insure that the general power supply has been isolated

- Qualified personnel according to the supplied schemes must carry out the electrical connections at the control panel.
- Insure that the voltage and the frequency shown on the technical plate correspond to the connecting power supply.

Follow the connection of the unit and its accessories using adequate cabling for the power used, and respecting the country regulations. The dimensions of the cabling must be sufficient to support a voltage drop in start up phase inferior to 3% of the nominal

- For the general power supply of the unit, and its accessories, the use of adapters, multiple plugs and extension leads is to be avoided.
- **It is the responsibility of the installer to insure that the installation of the unit is as close as possible to the mains power supply, or sufficiently close to protect the electrical parts.**
- Connect the unit to an efficient power point, using the correct screws as supplied with the unit.
- In the unit with relay board the screws of the connectors must be screwed with tork equal to 0,5 Nm

13.9 Installation of CVU & PCU accessories

13.9.1 CVU speed control

Adaptable for wall installation, allows the possibility to select one of three fan speeds.

Present on the control panel is:

- On – Off switch;
- Three speed Selector switch.

Installation and fitting

1. Loosen the central screws;
2. Remove the cap;
3. Fix the base to the wall, approximately 1,5 metres from the floor surface;
4. Carry out electrical connections;
5. Replace cap, and tighten central screws.

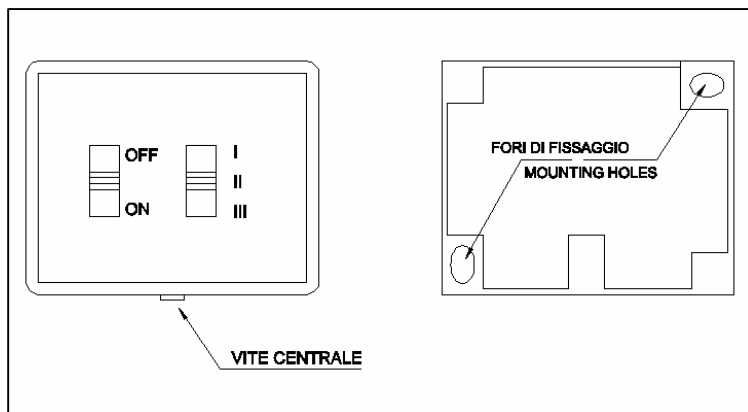

Technical characteristics

| | |
|-----------------|--|
| Power supply: | 230 +/- 10% Vac ; 50/60Hz |
| Control: | Manual : On / Off Manual : Min/ Med / Max |
| Relay capacity: | 6A with resistive load |

13.9.2 PCU Control panel

Adaptable for wall installation, the PCU Control Panel allows environmental temperature control, for both summer and winter. It also allows the possibility to select the three speed Electro-fan.

Present on the control panel is:

- On (summer ☀-winter ❄) – Off switch;
- Switch for temperature regulation;
- Three speed Selector switch;

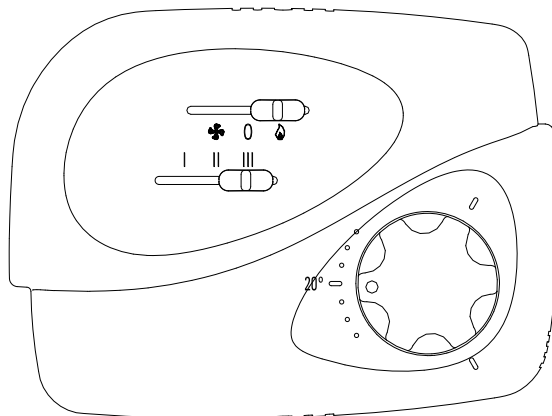

Technical characteristics

| | |
|-----------------|--|
| Power supply: | 230 +/- 10% Vac ; 50/60Hz |
| Control: | Manual : On / Off Manual : Min/ Med / Max |
| Relay capacity: | 6A with resistive load |

SECTION 14 – ELECTRICAL SCHEMES

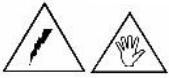

14.1 MINIAIR+ 03-06 direct connection

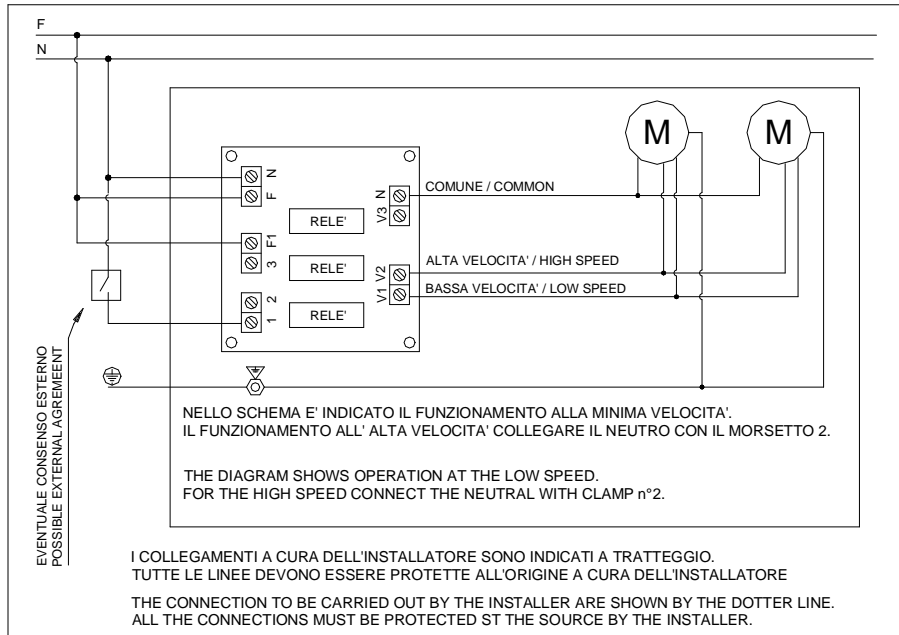

14.2 MINIAIR+ 03-06 connection with CVU speed control

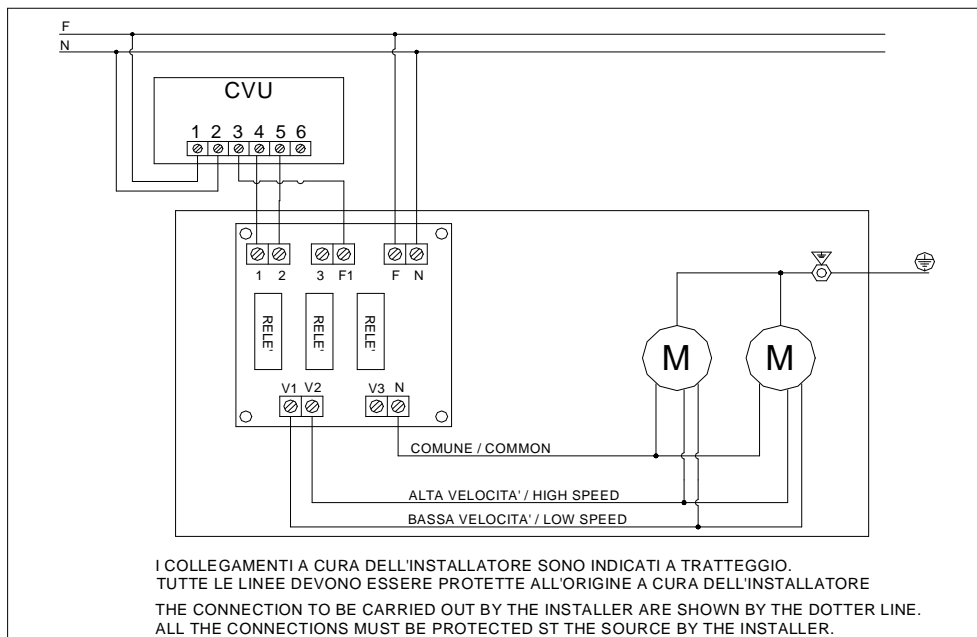

14.3 MINIAIR+ 03-06 connection with SKE & PCU control panel

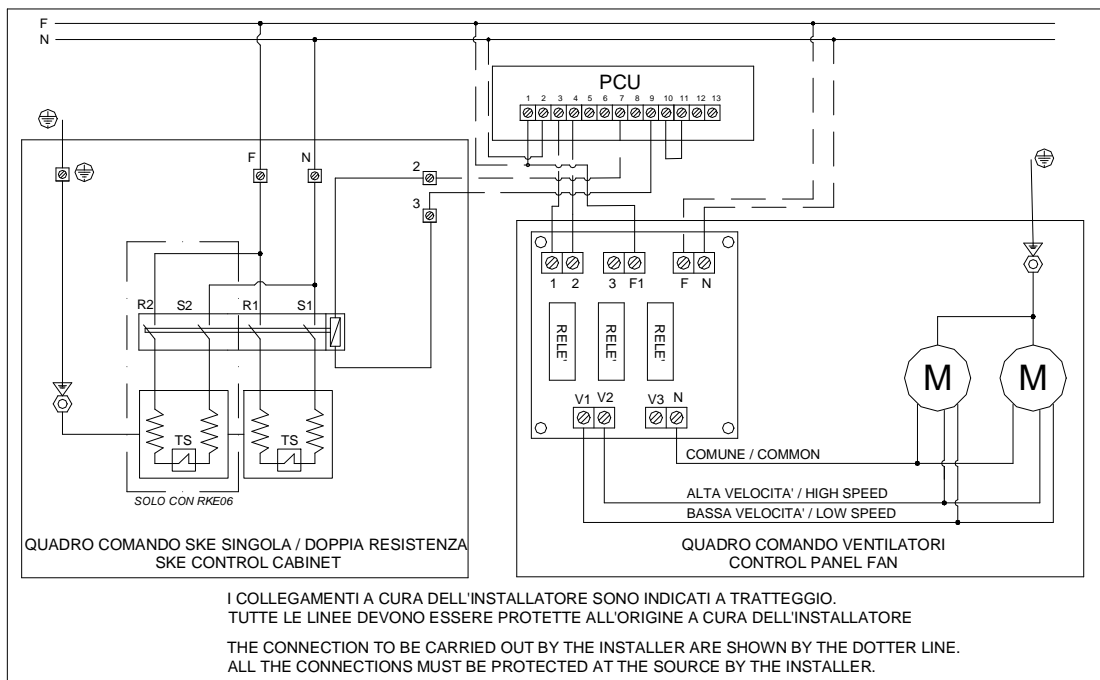

14.4 MINIAIR+ 10-14-19-25 direct connection

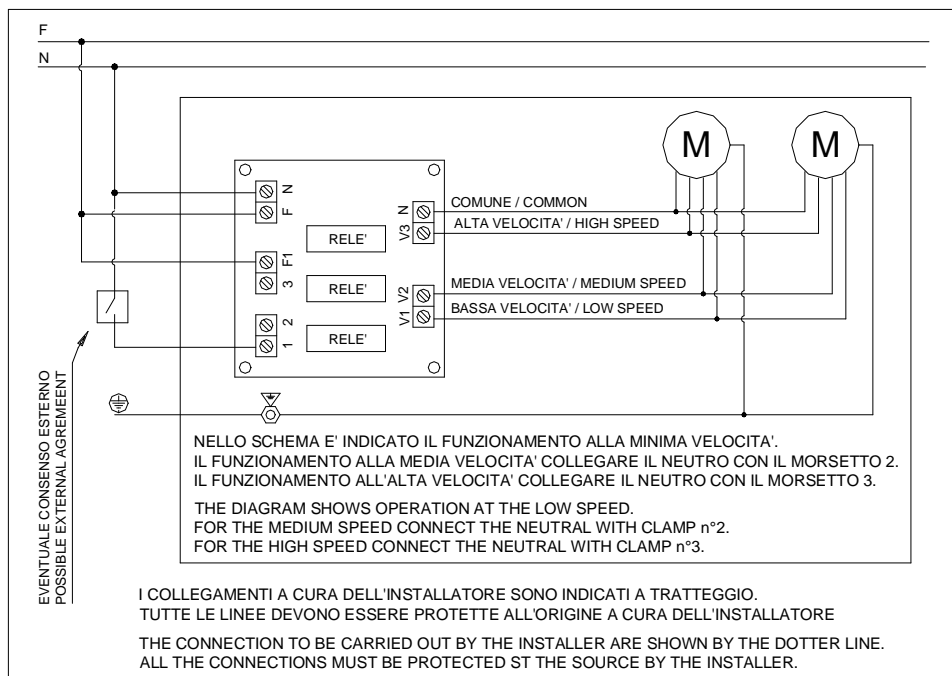

14.5 MINIAIR+ 10-14-19-25 connection with CVU speed control

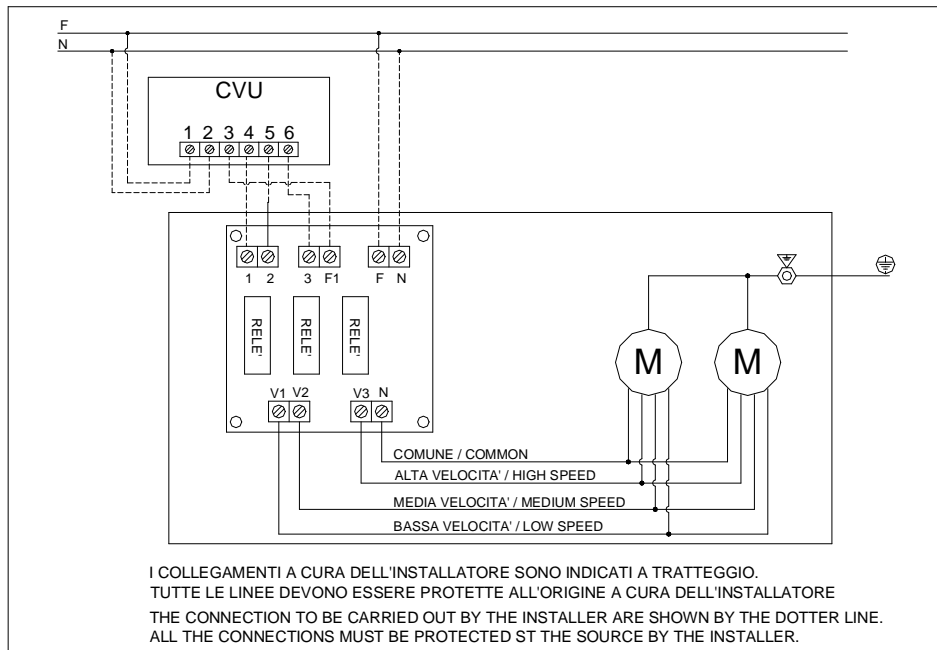

14.6 MINIAIR+ 10-14-19-25 connection with SKE & PCU control panel

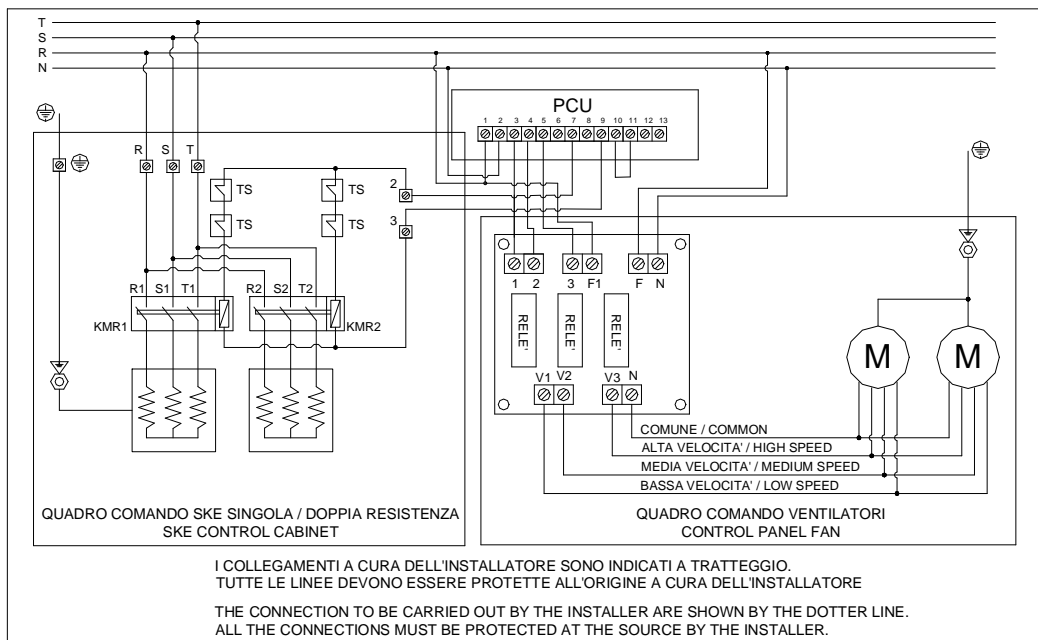

14.7 MINIAIR+ 30 direct connection

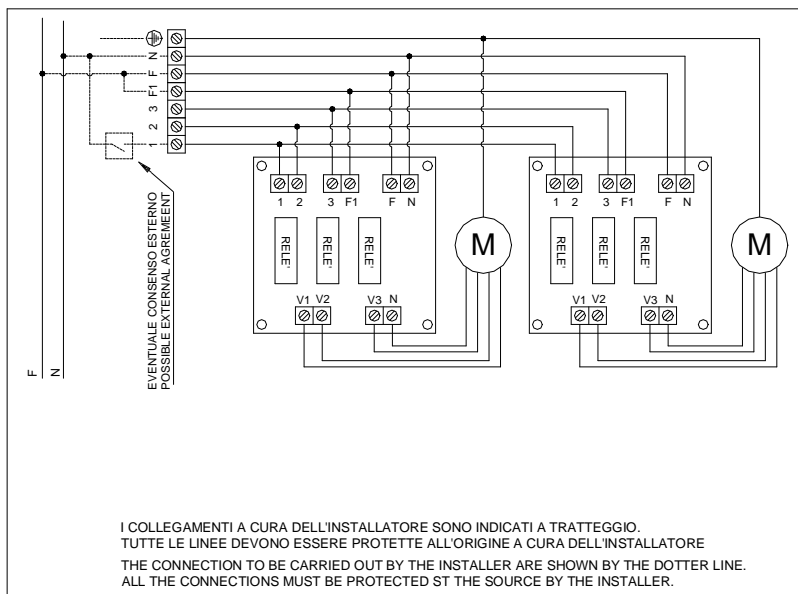

14.8 MINIAIR+ 30 connection with CVU speed control

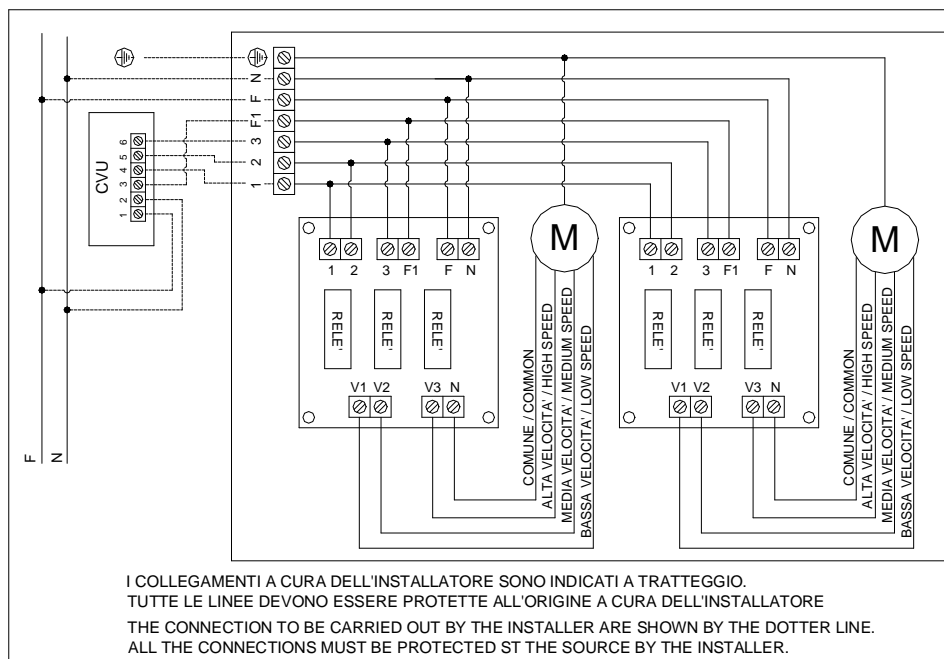

14.9 MINIAIR+ 30 connection with SKE & PCU control panel

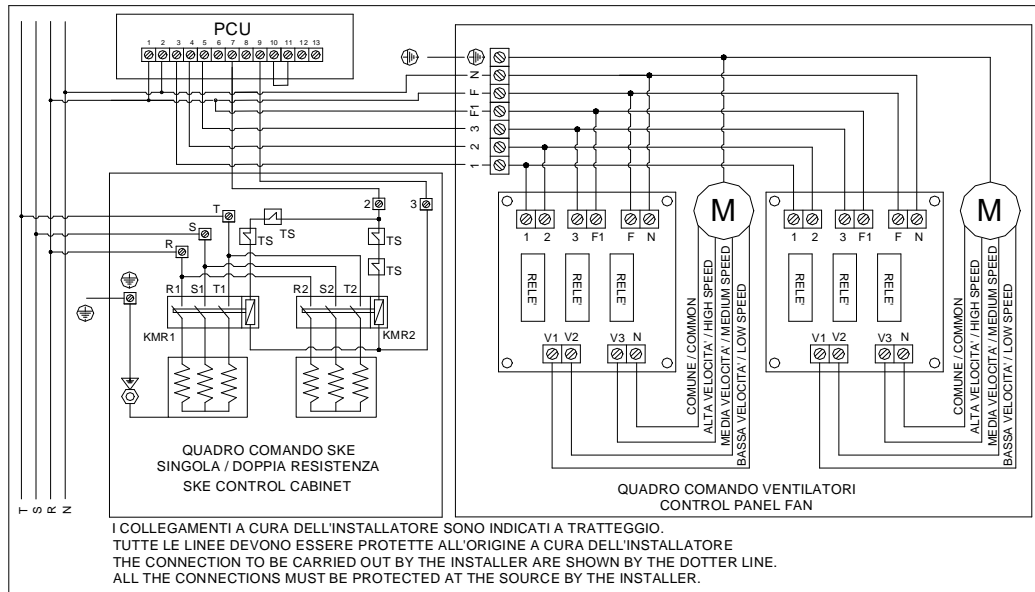

14.10 MINIAIR+ 40 direct connection

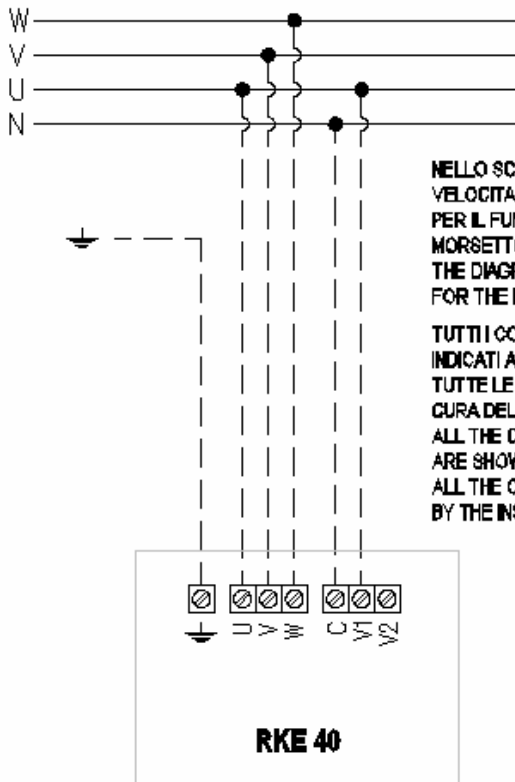

NELLO SCHEMA E' INDICATO IL COLLEGAMENTO ALLA MINIMA VELOCITA' PER IL FUNZIONAMENTO ALLA MASSIMA COLLEGARE LA FASE AL MORSETTO 2.
THE DIAGRAM SHOWS OPERATION AT LOW SPEED. FOR THE HIGH SPEED CONNECT THE PHASE WITH CLAMP N°2.
TUTTI I COLLEGAMENTI A CURA DELL'INSTALLATORE SONO INDICATI A TRATTEGGIO.
TUTTE LE LINEE DEVONO ESSERE PROTETTE ALL'ORIGINE A CURA DELL'INSTALLATORE.
ALL THE CONNECTION TO BE CARRIED OUT BY THE INSTALLER ARE SHOWN BY DOTTED LINE.
ALL THE CONNECTIONS MUST BE PROTECTED AT THE SOURCE BY THE INSTALLER.

14.11 MINIAIR+ 40 connection with CVU speed control

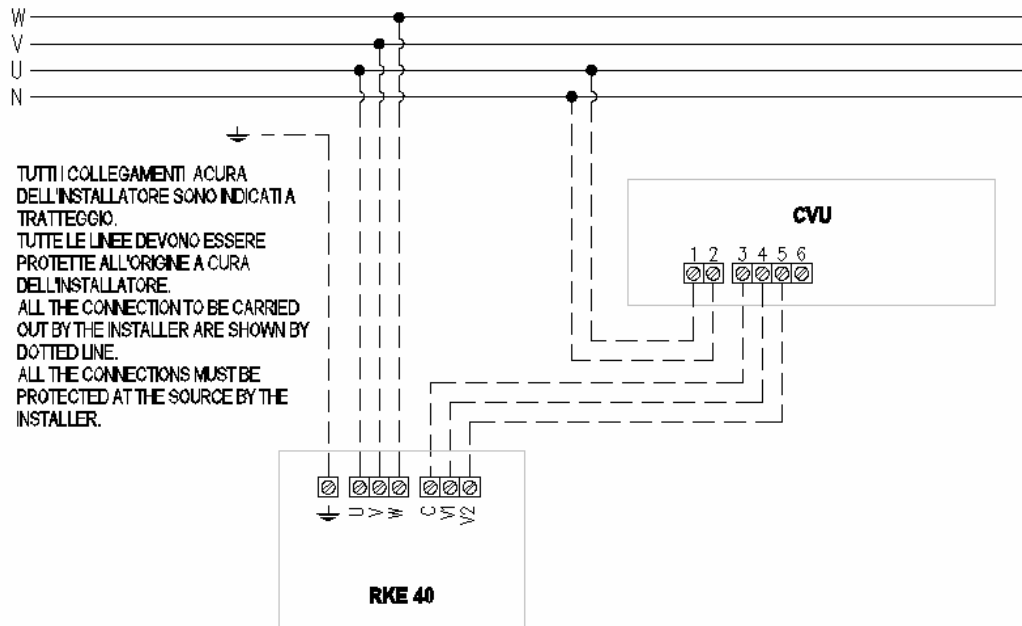

14.12 MINIAIR+ 30 connection with SKE & PCU control panel

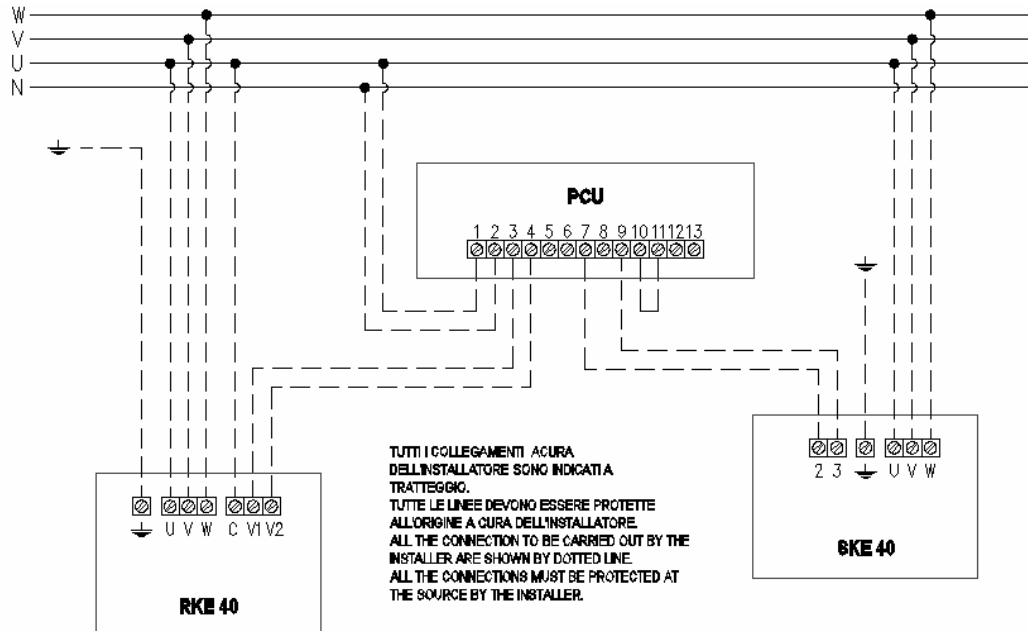

SECTION 15 – PRE-START CHECKLIST

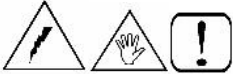

6.1 Checks prior to initial start-up

Before turning on the apparatus verify the following:

1. Fixing of unit to ceiling;
2. Connection of ducts;
3. Correct condensation run-off;
4. Connection of mains supply;
5. Closing of all electrical clamps.

SECTION 16 – STANDARD MAINTENANCE



BEFORE FOLLOWING ANY TYPE OF MAINTENANCE OPERATION, BE CERTAIN THAT THE APPARATUS MAY NOT CASUALLY OR ACCIDENTALLY BE CONNECTED TO THE ELECTRICAL MAINS SUPPLY. THEREFORE IT IS NECESSARY TO SHUTDOWN THE UNIT'S POWER SUPPLY PRIOR TO MAINTENANCE.

- It is the responsibility of the user to carry out all types of maintenance operations.
- Only personnel previously trained and qualified may carry out maintenance operations.
- Should the apparatus require disassembly, hand protection is required

16.1 Monthly maintenance

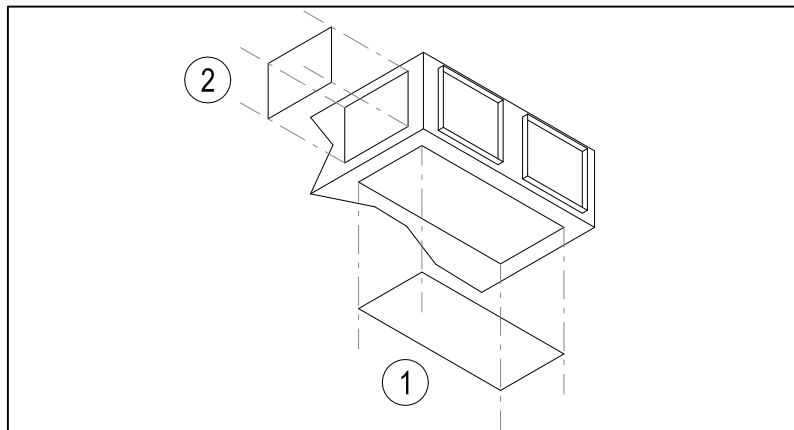

16.1.1 Filter section checklist

Possibility for inspection to replace filters from below **1** and laterally **2**

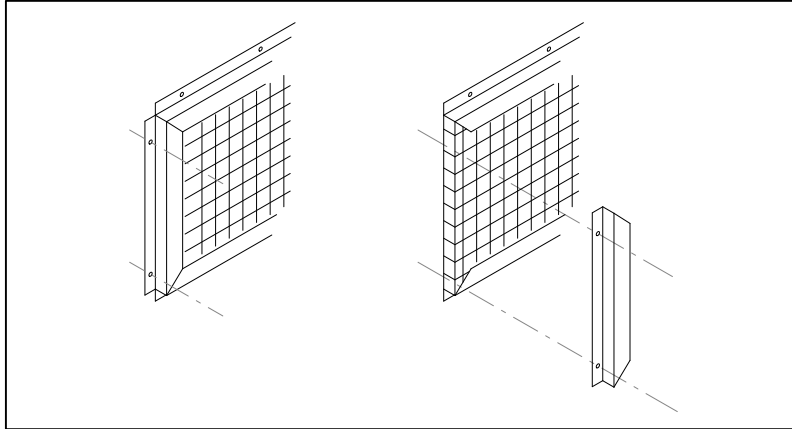

To remove filter, dis-assemble the guides and extract filter.

For the cleaning, utilize a vacuum cleaner or wash with normal detergent and warm water, allow to dry well. Remember to assemble the filter before operating the unit.

16.1.2 Recuperator Checklist

Verify that the plate exchanger does not demonstrate signs of impurity, as this may lower significantly its efficiency. It is possible to dismantle the recuperator from below, removing the condensation drip tray.

Unscrew the plugs 1, remove the tray and extract the recuperator pack

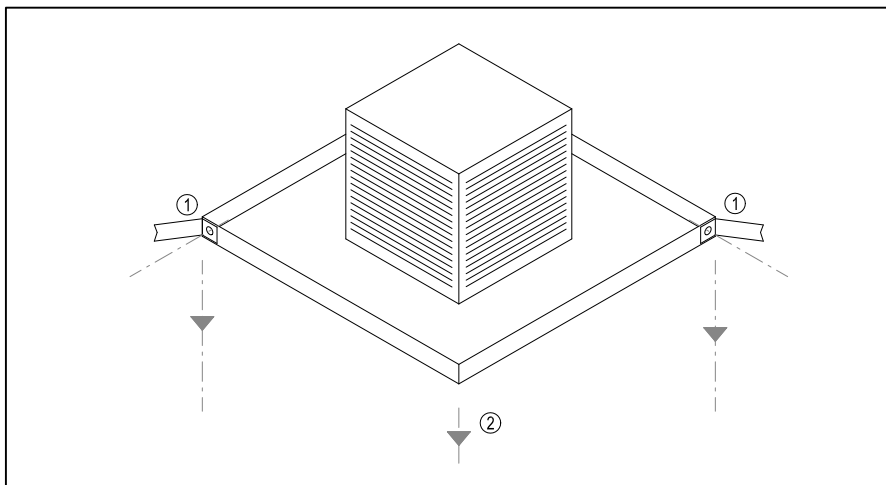

16.1.3 Condensation discharge Checklist

Remove side panel and clean, if necessary, the dirt and impurities that have formed in the condensation tray. Also check the efficiency of the siphon.

16.1.4 Water coil Checklist

Check that the coil exchanger (optional) is clean and in perfect state to guarantee the normal levels of performance.

16.2 Yearly maintenance

Check that all the electrical equipment, in particular the fixing of the electrical connections.

Check the tightness of all nut, bolts, flanges and hydraulic connections that the vibrations of the machine may have loosened.

SECTION 17 – TROUBLESHOOTING



17.1 Finding Faults

| SYMPTOMS | REASON |
|--|---|
| The motor does not turn | <ul style="list-style-type: none">• Power supply not present• The thermostat switches are not in their exact functioning position• Material/foreign bodies blocking moving parts• Loose electrical connections |
| Loss of performance after a period of satisfactory running | <ul style="list-style-type: none">• The filter and plate exchanger are dirty• Obstruction present in ducts |

SECTION 18 – MATERIAL DISPOSAL



18.1 Material Disposal

At the end of the productive life cycle, the MINIAIR+ Unit must be dismantled and disposed of respecting the operational regulations present in its country of installation.
The materials that the unit is constructed of are:

- Aluzink sheet metal;
- Zinc-plated sheet metal;
- Aluminium;
- Copper;
- Polyester;
- Polyethylene;
- Inox Stainless Steel;
- Plastic.



www.lennox europe.com

BELGIUM, LUXEMBOURG
www.lennoxbelgium.com

CZECH REPUBLIC
www.lennox.cz

FRANCE
www.lennoxfrance.com

GERMANY
www.lennoxdeutschland.com

GREAT BRITAIN
www.lennoxuk.com

NETHERLANDS
www.lennoxnederland.com

POLAND
www.lennoxpolska.com

PORTUGAL
www.lennoxportugal.com

RUSSIA
www.lennoxrussia.com

SLOVAKIA
www.lennoxdistribution.com

SPAIN
www.lennoxspain.com

UKRAINE
www.lennoxrussia.com

OTHER COUNTRIES
www.lennoxdistribution.com

Due to Lennox's ongoing commitment to quality, the Specifications, Ratings and Dimensions are subject to change without notice and without incurring liability.

Improper installation, adjustment, alteration, service or maintenance can cause property damage or personal injury.

Installation and service must be performed by a qualified installer and servicing agency.



MINIAIR-IOM-0507-E