

# Application guide

## MINIAIR / MINIAIR +



- Providing indoor climate comfort





## INTRODUCTION

The MINIAIR series AHU units are dedicated to all those air conditioning installations that require compact units because of not enough technical spaces. Available with a wide range of accessories, they allow a complete series of filtering, heating, cooling and humidifying treatments as well as they are suitable for the most of civil, commercial and industrial applications. Robustness, easy installation and product flexibility are the other characteristics of this series. MINIAIR series consists of 7 sizes, to cover 500 ÷ 6450 m<sup>3</sup>/h airflow range, with 2, 4, 6 row water coils.

The heat recovery units MINIAIR+ are designed and developed for residential and commercial applications and allow the room air renewal with a sure energy saving. In fact, where the room air renewal is needed, the unit transfers heat between the fresh air and the room air, otherwise would be lost. These units may be integrated with traditional heating and cooling systems, but they can operate also autonomously if equipped with the proper accessories.

MINIAIR+ series, for both horizontal and vertical configuration, consists of 8 sizes, to cover 500 ÷ 4600 m<sup>3</sup>/h airflow rates.

## INDEX

### SECTION 1 – TECHNICAL FEATURES MINIAIR

|     |                                      |        |
|-----|--------------------------------------|--------|
| 1.1 | General features                     | page 2 |
| 1.2 | Unit dimensions                      | page 2 |
| 1.3 | Available versions as basic version  | page 3 |
| 1.4 | Unit technical data and performances | page 3 |

### SECTION 2 – ACCESSORIES MINIAIR

|     |                       |         |
|-----|-----------------------|---------|
| 2.1 | Available accessories | page 8  |
| 2.2 | Air pressure drop     | page 15 |

### SECTION 3 – ELECTRONIC CONTROL MINIAIR

|     |                            |         |
|-----|----------------------------|---------|
| 3.1 | On/off control devices     | page 19 |
| 3.2 | Modulating control devices | page 19 |

### SECTION 4 – UNIT IDENTIFICATION MINIAIR

|   |                     |         |
|---|---------------------|---------|
| 4 | Unit identification | page 19 |
|---|---------------------|---------|

### SECTION 5 – TECHNICAL FEATURES MINIAIR+

|     |                                 |         |
|-----|---------------------------------|---------|
| 5.5 | General features                | page 20 |
| 5.6 | Unit dimensions                 | page 20 |
| 5.7 | Technical data and performances | page 21 |
| 5.8 | Possible orientations           | page 21 |

### SECTION 6 – ACCESSORIES MINIAIR+

|      |                                  |         |
|------|----------------------------------|---------|
| 6.1  | Accessoires                      | page 23 |
| 6.2  | Electric heater SKE              | page 23 |
| 6.3  | Re-heating section SKW           | page 23 |
| 6.4  | Cooling section SAF              | page 24 |
| 6.5  | Adjusting damper SKR             | page 24 |
| 6.6  | 3-way mixing box MS3             | page 25 |
| 6.7  | Soft bag filter FTK              | page 26 |
| 6.8  | Built-in inverter motors DDE     | page 26 |
| 6.9  | Fan speed control CVU            | page 26 |
| 6.10 | Unit control panel PCU/PCUR      | page 27 |
| 6.11 | Air filter pressure switch PSTD  | page 27 |
| 6.12 | Antifreeze thermostat TEG        | page 27 |
| 6.13 | On/off damper servocontrol SSE   | page 27 |
| 6.14 | Circular duct connection BCC     | page 28 |
| 6.15 | Antivibrating duct joint GAT     | page 28 |
| 6.16 | 3 way on/off water valve V3/S230 | page 28 |
| 6.17 | Roof cover TPR                   | page 28 |
| 6.18 | Modulating control devices       | page 29 |

|                                       |         |
|---------------------------------------|---------|
| SECTION 7 – AIR PERFORMANCES MINIAIR+ | page 31 |
|---------------------------------------|---------|

### SECTION 8 – UNIT IDENTIFICATION MINIAIR+

|   |                     |         |
|---|---------------------|---------|
| 8 | Unit identification | page 35 |
|---|---------------------|---------|

## SECTION 1 – TECHNICAL FEATURES

### 1.1 GENERAL FEATURES

- Precoated steel frame RAL 9002
- Sandwich panels, galvanized steel sheet metal inside and RAL 9002 precoated steel sheet metal outside
- Unit inspection by lower panels, removable for fan and coils, provided with hasps for filter
- Thermal and sound insulation made from Rockwool, 10 mm (10 to 40 model) or 20 mm thickness (50 and 60 models)
- G3 efficiency class synthetic cell filter
- Cu tube and Al fins water coils with steel or copper headers, easy removable
- Stainless steel drain tray with a special fixing system for an easy extraction; side condensate outlet
- Electric heaters made from armored carbon steel modules, complete with electric board, relays and safety thermostat
- 3- speed double inlet forward curved direct driven fans; fan groups mounted on anti-vibrators
- Wholly wired main electric board fitted with speed relays

### 1.2 UNIT DIMENSIONS

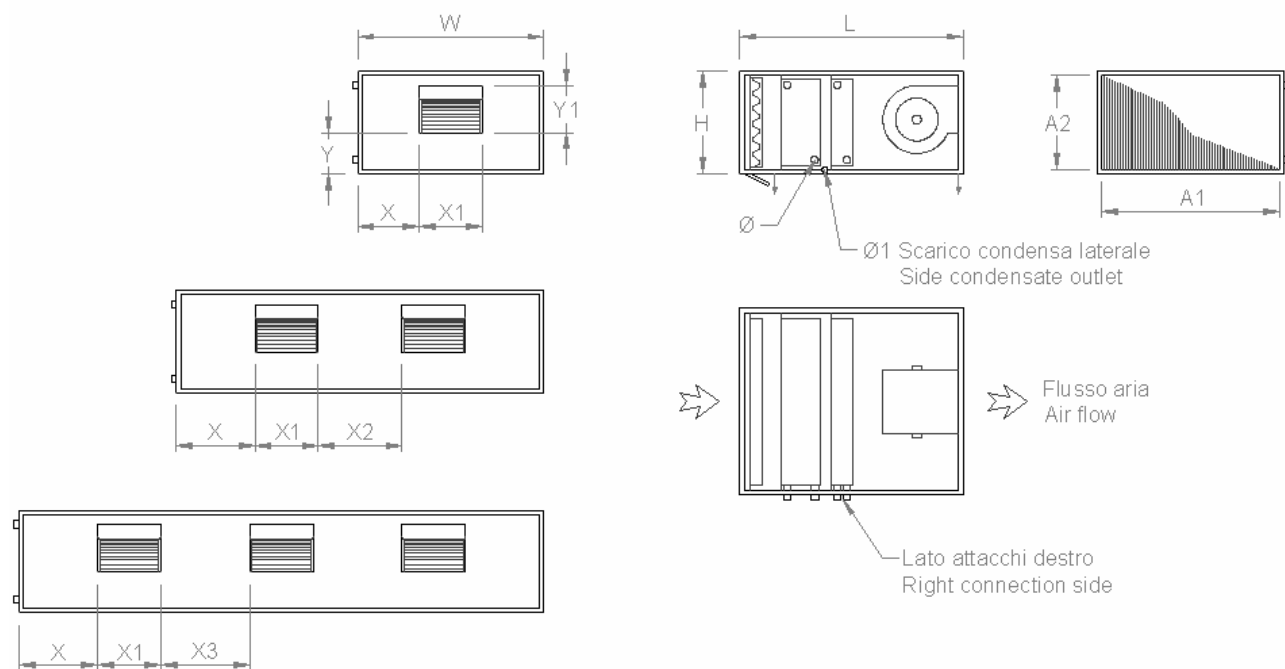

| MODEL         |           | 10    | 20    | 25    | 30    | 40     | 50      | 60      |
|---------------|-----------|-------|-------|-------|-------|--------|---------|---------|
| <b>W</b>      | <b>mm</b> | 710   | 1070  | 1400  | 1400  | 1680   | 1780    | 2000    |
| <b>H</b>      | <b>mm</b> | 390   | 390   | 390   | 390   | 390    | 480     | 480     |
| <b>L</b>      | <b>mm</b> | 850   | 850   | 850   | 850   | 850    | 960     | 960     |
| <b>φ 2R</b>   |           | 3/4"  | 3/4"  | 3/4"  | 3/4"  | 1"     | 1"      | 1"      |
| <b>φ 4R</b>   |           | 3/4"  | 3/4"  | 1"    | 1"    | 1"     | 1"      | 1 1/4"  |
| <b>φ 6R</b>   |           | 3/4"  | 1"    | 1"    | 1"    | 1 1/4" | 1 1/4"  | 1 1/4"  |
| <b>φ1</b>     | <b>mm</b> | 20    | 20    | 20    | 20    | 20     | 20      | 20      |
| <b>X1</b>     | <b>mm</b> | 240   | 306   | 240   | 240   | 306    | 306     | 306     |
| <b>Y1</b>     | <b>mm</b> | 216   | 270   | 216   | 270   | 270    | 270     | 270     |
| <b>X2</b>     | <b>mm</b> | -     | -     | 318   | 318   | 418    | 435     | -       |
| <b>X3</b>     | <b>mm</b> | -     | -     | -     | -     | -      | -       | 285     |
| <b>A1</b>     | <b>mm</b> | 670   | 1030  | 1360  | 1360  | 1640   | 1720    | 1940    |
| <b>A2</b>     | <b>mm</b> | 350   | 350   | 350   | 350   | 350    | 420     | 420     |
| <b>X</b>      | <b>mm</b> | 235   | 382   | 301   | 301   | 325    | 366     | 256     |
| <b>Y</b>      | <b>mm</b> | 136   | 82    | 136   | 82    | 82     | 160     | 160     |
| <b>Weight</b> | <b>kg</b> | 52÷60 | 60÷70 | 75÷88 | 78÷90 | 96÷110 | 101÷120 | 120÷140 |

### 1.3 AVAILABLE VERSIONS AS BASIC UNIT

- MINIAIR2** : single 2 row water coil
- MINIAIR4** : single 4 row water coil
- MINIAIR6** : single 6 row water coil
- MINIAIR42** : two water coils (4+2 row)
- MINIAIR62** : two water coils (6+2 row)
- MINIAIR4E** : single 4 row water coil and electric heater (max 2 stages)
- MINIAIR6E** : single 6 row water coil and electric heater (max 2 stages)
- MINIAIR4S** : single 4 row water coil and droplet eliminator
- MINIAIR6S** : single 6 row water coil and droplet eliminator

#### 1.4 UNIT TECHNICAL DATA AND PERFORMANCES

| MODEL                |                   | Aeraulic performances (*) |      |      |      |      |      |      |
|----------------------|-------------------|---------------------------|------|------|------|------|------|------|
|                      |                   | 10                        | 20   | 25   | 30   | 40   | 50   | 60   |
| Airflow rate         | m <sup>3</sup> /h | 1040                      | 2150 | 2740 | 3360 | 3950 | 5070 | 6450 |
| E.S.P.               | Pa                | 150                       | 150  | 150  | 150  | 150  | 150  | 150  |
| Sound level (at 1 m) | dB(A)             | 51                        | 55   | 55   | 57   | 58   | 57   | 59   |

(\*) 4-row coil at max fan speed

| MODEL            |   | Fan electrical features |     |         |         |         |         |         |
|------------------|---|-------------------------|-----|---------|---------|---------|---------|---------|
|                  |   | 10                      | 20  | 25      | 30      | 40      | 50      | 60      |
| Shaft power      | W | 147                     | 350 | 2 x 350 | 2 x 350 | 2 x 350 | 2 x 420 | 3 x 420 |
| Poles            |   | 4                       | 4   | 4       | 4       | 4       | 4       | 4       |
| Fan speeds       |   | 3                       | 3   | 3       | 3       | 3       | 3       | 3       |
| Max current      | A | 1,9                     | 3,0 | 2 x 3,0 | 2 x 3,0 | 2 x 3,0 | 2 x 3,8 | 3 x 3,8 |
| Protection class |   | min. IP31               |     |         |         |         |         |         |
| Isolation class  |   | B                       | F   | F       | F       | F       | B       | B       |
| Power supply     |   | 230 V – 1ph – 50 Hz     |     |         |         |         |         |         |

| MODEL |              | Heating capacities (**) |      |      |      |      |      |      |      |
|-------|--------------|-------------------------|------|------|------|------|------|------|------|
|       |              | 10                      | 20   | 25   | 30   | 40   | 50   | 60   |      |
| 2R    | Max capacity | kW                      | 9,5  | 18,5 | 24,2 | 27,7 | 33,3 | 34,9 | 41,2 |
|       | Water flow   | m <sup>3</sup> /h       | 0,84 | 1,63 | 2,13 | 2,44 | 2,93 | 3,07 | 3,63 |
|       | Water Δp     | kPa                     | 22   | 23   | 21   | 27   | 26   | 26   | 17   |
| 4R    | Max capacity | kW                      | 13,8 | 27,7 | 35,8 | 42,5 | 50,3 | 58,1 | 71,3 |
|       | Water flow   | m <sup>3</sup> /h       | 1,21 | 2,44 | 3,15 | 3,74 | 4,43 | 5,12 | 6,28 |
|       | Water Δp     | kPa                     | 21   | 29   | 23   | 32   | 26   | 19   | 23   |
| 6R    | Max capacity | kW                      | 14,9 | 30,5 | 39,1 | 47,1 | 55,7 | 67,0 | 83,3 |
|       | Water flow   | m <sup>3</sup> /h       | 1,31 | 2,68 | 3,44 | 4,14 | 4,90 | 5,89 | 7,33 |
|       | Water Δp     | kPa                     | 22   | 26   | 21   | 30   | 23   | 18   | 19   |

(\*\*) air inlet temperature 20°C; water temperature 70°/60° C; airflow rate as above

| MODEL |               | Cooling capacities (***) |      |      |      |      |      |      |      |
|-------|---------------|--------------------------|------|------|------|------|------|------|------|
|       |               | 10                       | 20   | 25   | 30   | 40   | 50   | 60   |      |
| 4R    | Max capacity  | kW                       | 6,0  | 12,1 | 15,7 | 18,2 | 21,6 | 24,1 | 32,5 |
|       | Sensible cap. | kW                       | 4,5  | 8,9  | 11,6 | 13,6 | 16,1 | 19,7 | 25,6 |
|       | Water flow    | m <sup>3</sup> /h        | 1,04 | 2,07 | 2,69 | 3,12 | 3,69 | 4,13 | 5,57 |
|       | Water Δp      | kPa                      | 21   | 29   | 23   | 32   | 26   | 19   | 23   |
| 6R    | Max capacity  | kW                       | 7,1  | 14,3 | 18,5 | 21,9 | 26,2 | 34,3 | 42,1 |
|       | Sensible cap. | kW                       | 5,0  | 10,2 | 13,2 | 15,7 | 18,7 | 24,6 | 30,6 |
|       | Water flow    | m <sup>3</sup> /h        | 1,21 | 2,46 | 3,17 | 3,76 | 4,49 | 5,88 | 7,21 |
|       | Water Δp      | kPa                      | 26   | 29   | 24   | 33   | 25   | 23   | 24   |

(\*\*\*) air inlet condition 27°C 47% RH; water temperature 7°/12° C; airflow rate as above

### 1.4.1 HEATING CAPACITIES AT NOT NOMINAL CONDITIONS

To determine the heating capacities when the working conditions are different from nominal ones (both for air and water side), it is possible to use the following wording, valid for purely sensible heat exchange (heating or cooling without dehumidification) :

$$W = W_{sp} * (T_{wi} - T_{ai}) \text{ [Watt]}$$

where  $T_{wi}$  [°C] is the inlet water temperature,  $T_{ai}$  [°C] is the inlet air temperature and  $W_{sp}$  [W/°C] the average specific capacity (at nominal airflow rate) depending on the considered model.

| MODEL |                          |      | 10  | 20  | 25  | 30  | 40   | 50   | 60   |
|-------|--------------------------|------|-----|-----|-----|-----|------|------|------|
| 2R    | Average specif. capacity | W/°C | 200 | 390 | 510 | 585 | 700  | 735  | 870  |
| 4R    | Average specif. capacity | W/°C | 283 | 570 | 735 | 875 | 1036 | 1203 | 1480 |
| 6R    | Average specif. capacity | W/°C | 304 | 620 | 795 | 960 | 1135 | 1375 | 1710 |

### 1.4.2 COOLING CAPACITIES AT NOT NOMINAL CONDITIONS

The following tables show the cooling capacities for typical working conditions (both for air side and water side), at nominal airflow rate.

| Air in 32°C 50% RH – Water in/out 7/12°C |                |    |      |      |      |      |      |      |      |
|--|----------------|----|------|------|------|------|------|------|------|
| MODEL                                    |                |    | 10   | 20   | 25   | 30   | 40   | 50   | 60   |
| 4R                                       | Total capacity | kW | 9,9  | 19,9 | 25,7 | 30,3 | 35,8 | 42,0 | 55,4 |
|  | Sens.capacity  |    | 5,5  | 11,1 | 14,3 | 16,9 | 20,0 | 24,5 | 31,8 |
| 6R                                       | Total capacity | kW | 11,0 | 22,5 | 28,9 | 34,6 | 41,1 | 53,9 | 66,9 |
|  | Sens.capacity  |    | 6,1  | 12,4 | 15,9 | 19,1 | 22,6 | 29,8 | 37,1 |

| Air in 32°C 50% RH – Water in/out 9/14°C |                |    |     |      |      |      |      |      |      |
|--|----------------|----|-----|------|------|------|------|------|------|
| MODEL                                    |                |    | 10  | 20   | 25   | 30   | 40   | 50   | 60   |
| 4R                                       | Total capacity | kW | 8,8 | 17,7 | 23,0 | 27,0 | 31,9 | 36,8 | 48,9 |
|  | Sens.capacity  |    | 5,1 | 10,2 | 13,2 | 15,6 | 18,5 | 22,6 | 29,4 |
| 6R                                       | Total capacity | kW | 9,9 | 20,2 | 26,0 | 31,1 | 37,0 | 48,5 | 59,9 |
|  | Sens.capacity  |    | 5,6 | 11,5 | 14,8 | 17,7 | 21,0 | 27,6 | 34,4 |

| Air in 27°C 47% RH – Water in/out 9/14°C |                |    |     |      |      |      |      |      |      |
|--|----------------|----|-----|------|------|------|------|------|------|
| MODEL                                    |                |    | 10  | 20   | 25   | 30   | 40   | 50   | 60   |
| 4R                                       | Total capacity | kW | 4,9 | 9,7  | 12,7 | 14,5 | 17,2 | 18,5 | 25,4 |
|  | Sens.capacity  |    | 4,0 | 8,0  | 10,4 | 12,2 | 14,4 | 17,6 | 22,9 |
| 6R                                       | Total capacity | kW | 5,9 | 11,8 | 15,3 | 18,0 | 21,6 | 28,2 | 34,4 |
|  | Sens.capacity  |    | 4,5 | 9,2  | 11,9 | 14,2 | 16,8 | 22,2 | 27,5 |

### 1.4.3 AIR PERFORMANCE

The following curves are the air performances of MINIAIR units, size by size (4 row coil basic version) at the 3 fan speeds; 1 m sound pressure levels are also shown.

**MiniAir 10 (4R)**

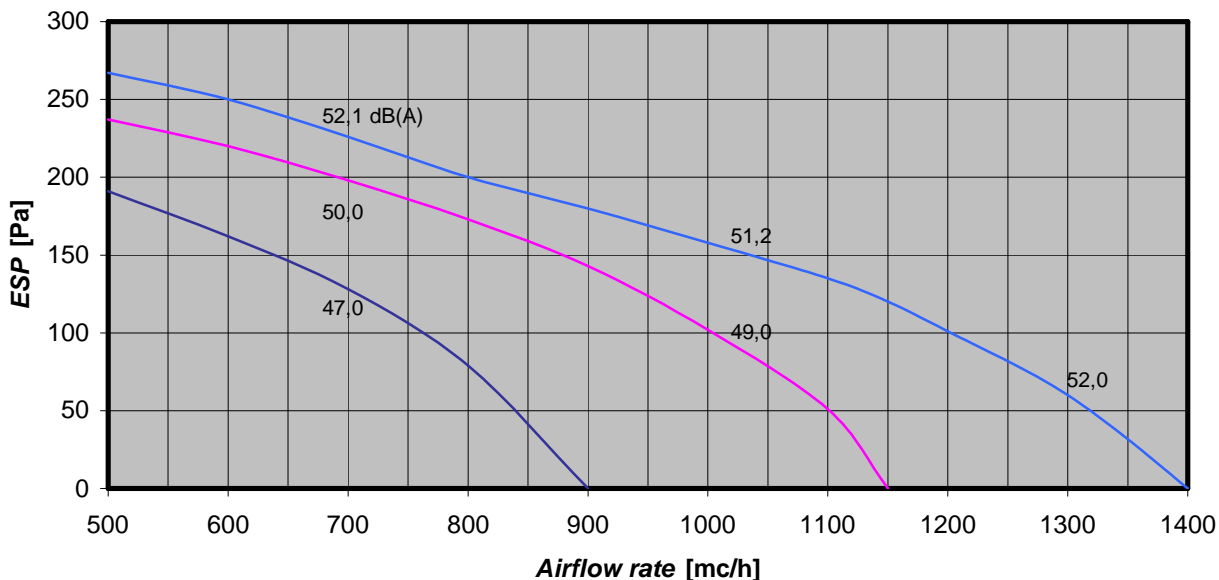

**MiniAir 20 (4R)**

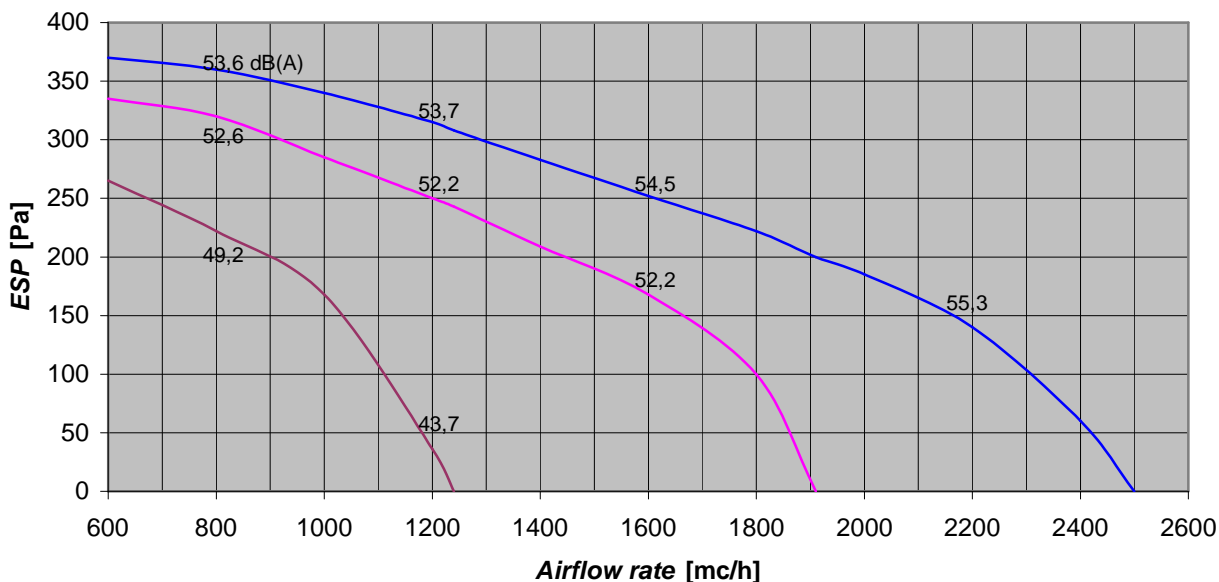

### MiniAir 25 (4R)

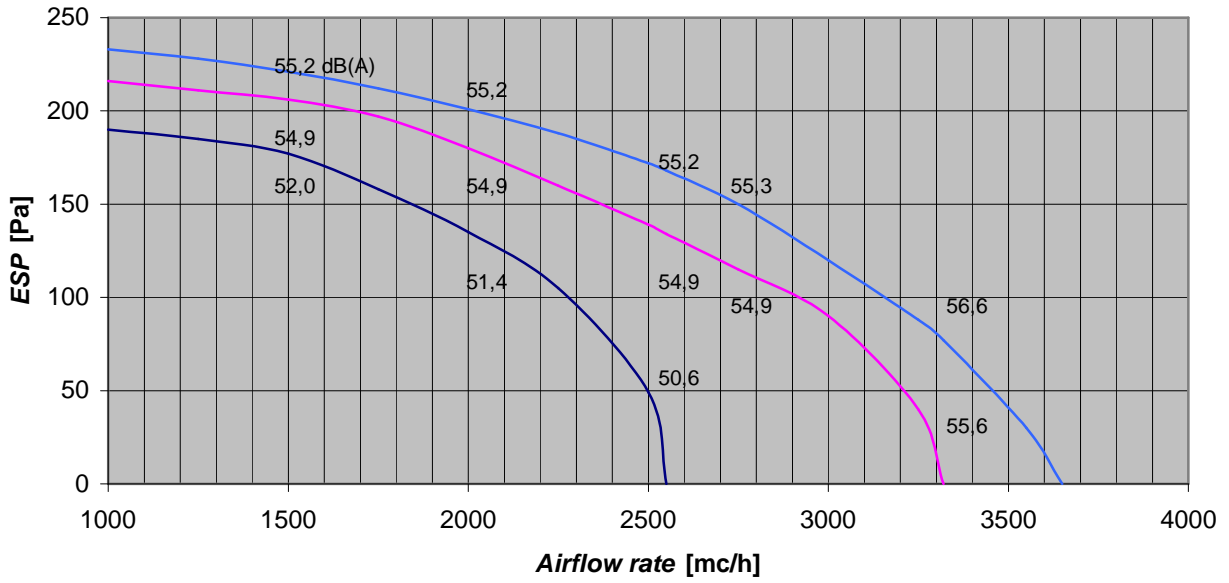

### MiniAir 30 (4R)

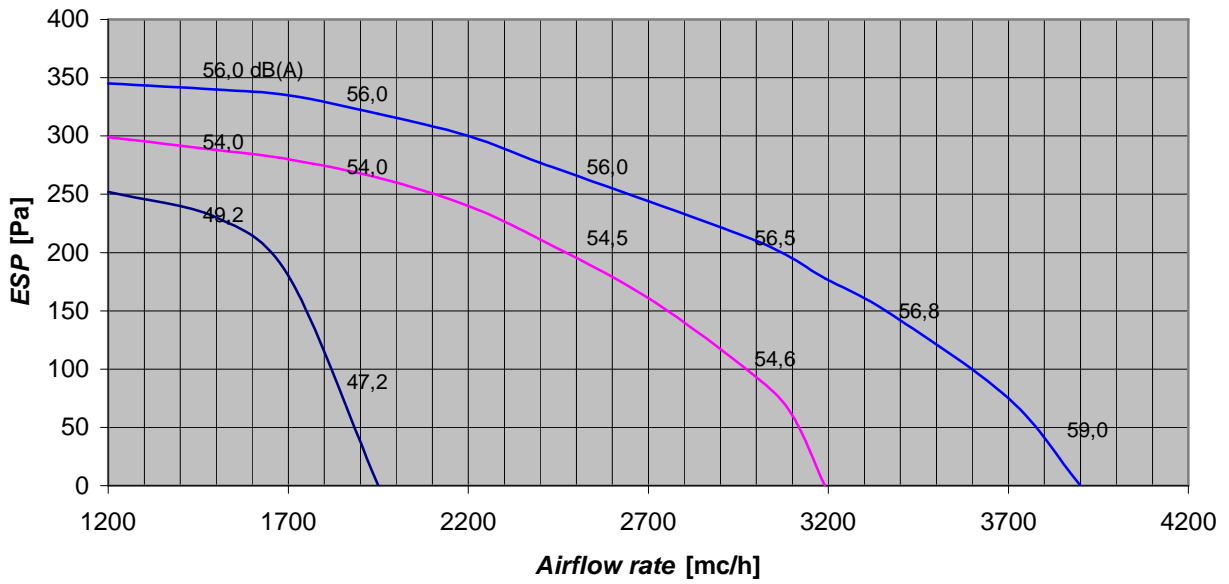



**MiniAir 40 (4R)**

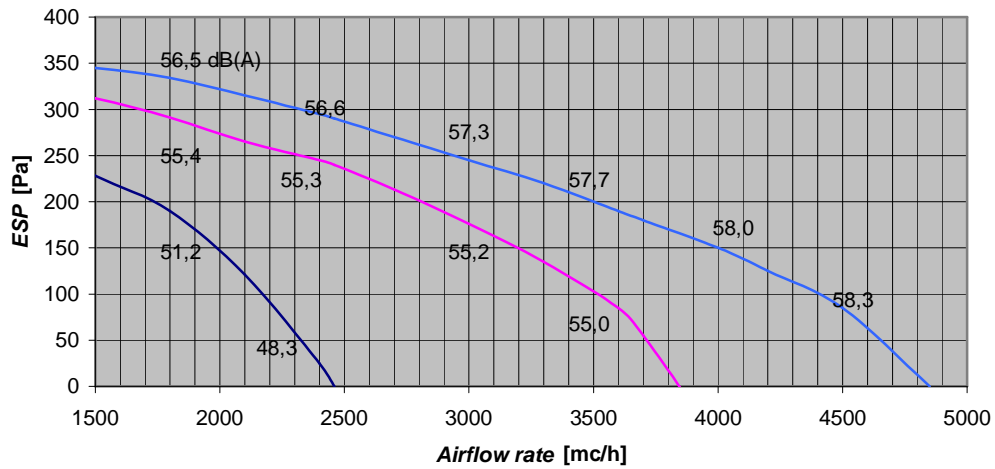

**MiniAir 50 (4R)**

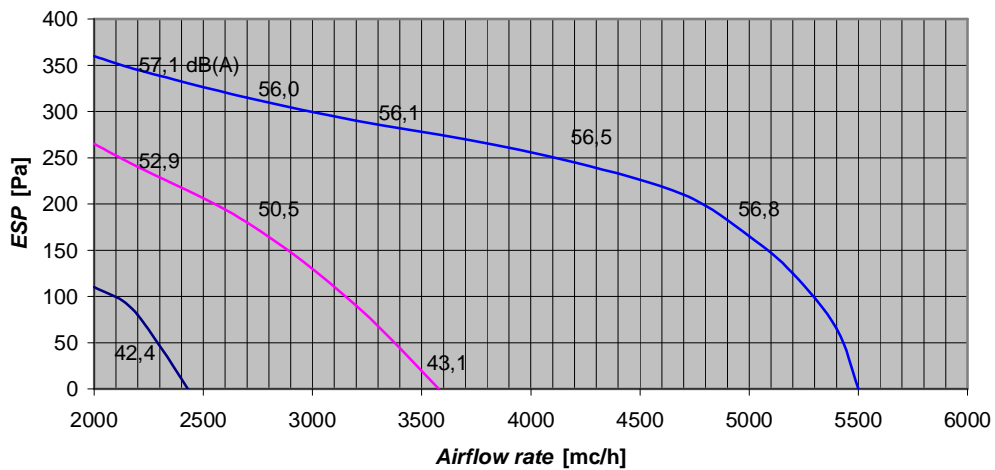

**MiniAir 60 (4R)**

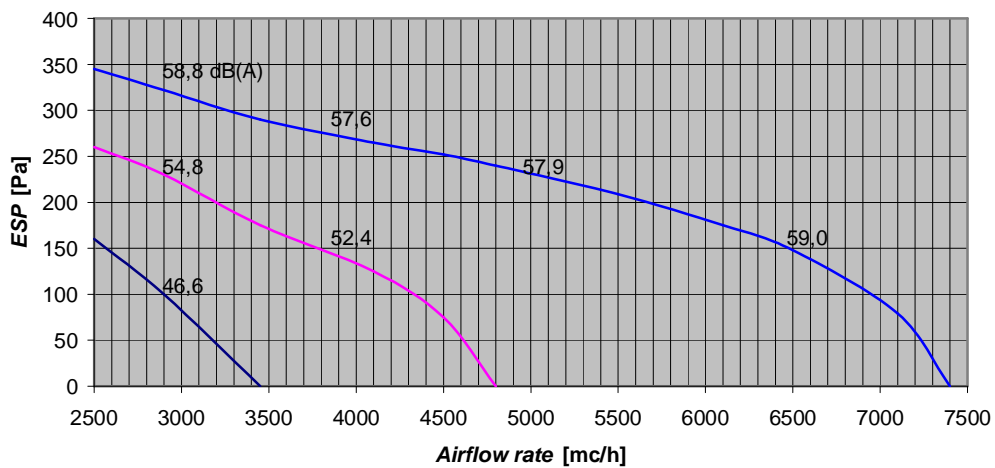

## SECTION 2 – ACCESSORIES

### 2.1 AVAILABLE ACCESSORIES

MINIAIR units can be provided with a complete series of accessories to allow a perfect adaptation to the most of compact installations.

For each model, the following accessories can be selected :

- **GRA** intake grill
- **SRR** adjusting damper
- **PAR** return plenum
- **CMS** 2 damper mixing box
- **SLR** return sound attenuator
- **FTM** F6 soft bag filter section
- **UPA** evaporative pack humidifier complete with droplet eliminator
- **UV** prearranged section for steam distributor
- **SRW** water coil re-heating section
- **BRE** electric heater section (max 3 stages)
- **SLM** supply sound attenuator
- **PCF** circular duct connections supply adaptor
- **PMA** supply plenum
- **BMA** adjusting fins supply grill

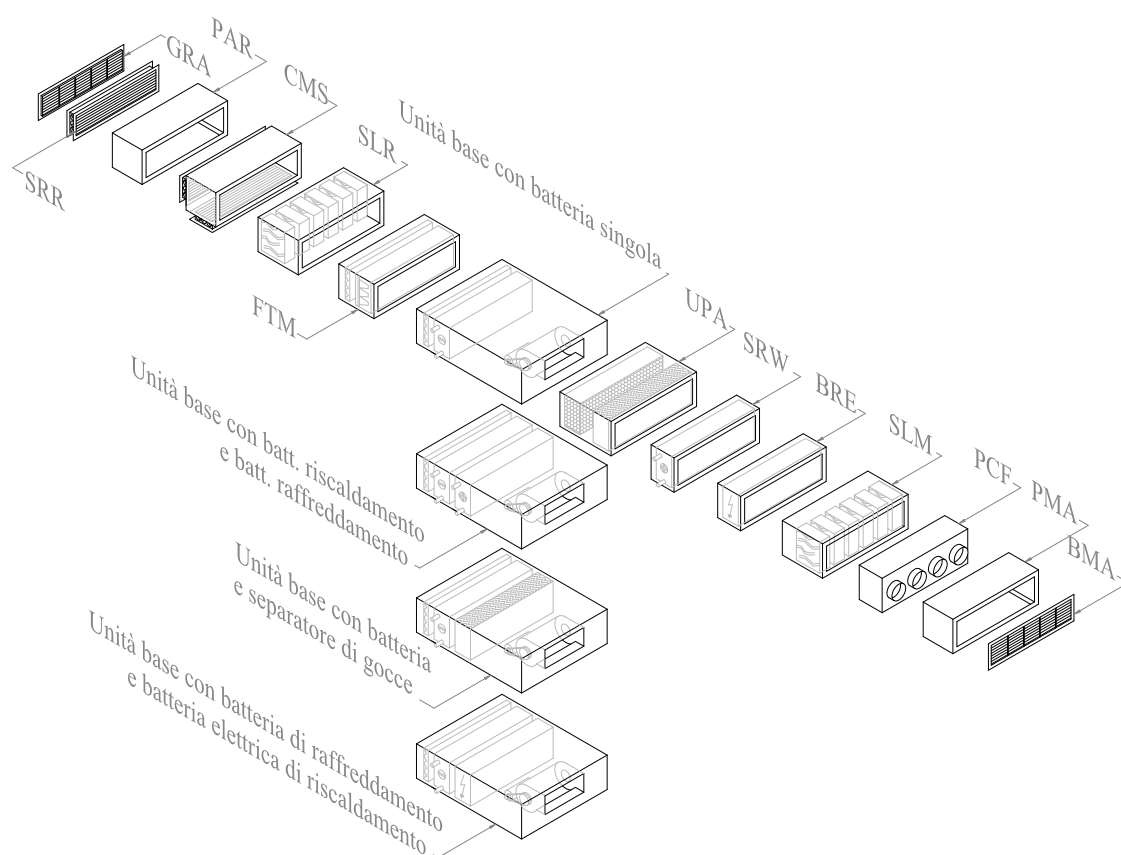

### 2.1.1 INTAKE GRILL GRA

Made from aluminium with one row inclined fixed fins, it meets PAR return plenum, on the rear or on the bottom.

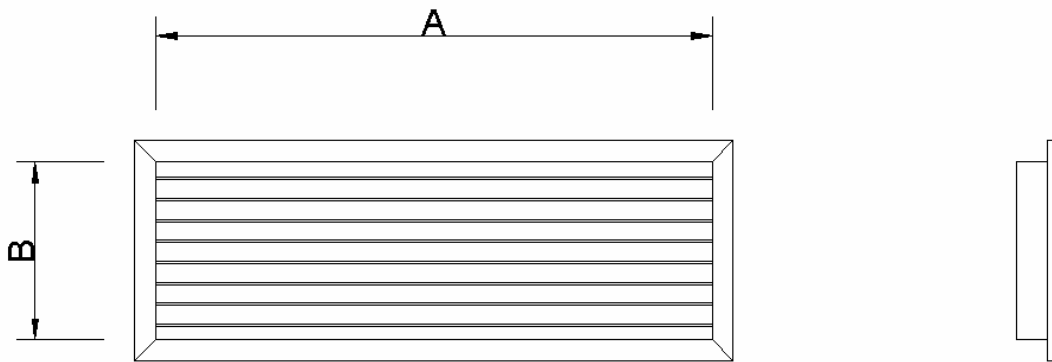

| MODEL    |    | 10  | 20  | 25   | 30   | 40   | 50   | 60   |
|----------|----|-----|-----|------|------|------|------|------|
| <b>A</b> | mm | 600 | 900 | 1300 | 1300 | 1500 | 1700 | 1900 |
| <b>B</b> | mm | 200 | 200 | 200  | 300  | 300  | 400  | 400  |

### 2.1.2 ADJUSTING DAMPER SRR

It allows the airflow rate adjustment and shut off and it is made from aluminium with ABS gear movement; the shaft is suitable for manual lever or electric servocontrol.

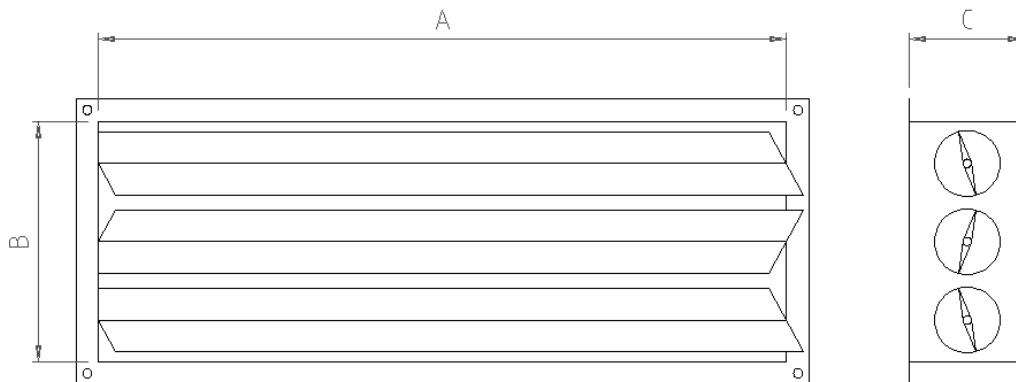

| MODEL    |    | 10  | 20  | 25   | 30   | 40   | 50   | 60   |
|----------|----|-----|-----|------|------|------|------|------|
| <b>A</b> | mm | 600 | 900 | 1300 | 1300 | 1500 | 1600 | 1800 |
| <b>B</b> | mm | 210 | 210 | 210  | 310  | 310  | 410  | 410  |
| <b>C</b> |    | 150 | 150 | 150  | 150  | 150  | 150  | 150  |

### 2.1.3 RETURN PLENUM PAR

It is prearranged for holes allowing the use of SRR damper or GRA grill (but not together in the same hole), lower down or behind.

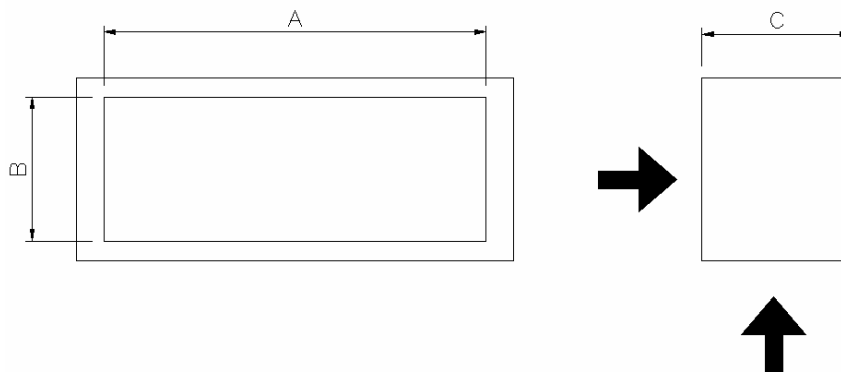

| MODEL |    | 10  | 20  | 25   | 30   | 40   | 50   | 60   |
|-------|----|-----|-----|------|------|------|------|------|
| A     | mm | 600 | 900 | 1300 | 1300 | 1500 | 1700 | 1900 |
| B     | mm | 200 | 200 | 200  | 300  | 300  | 400  | 400  |
| C     |    | 460 | 460 | 460  | 460  | 460  | 480  | 480  |

### 2.1.4 MIXING BOX CMS

It allows to adjust and mix return/recirculated airflow and outside renewal airflow together.

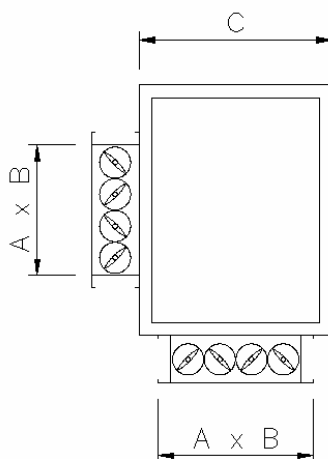

| MODEL |    | 10  | 20  | 25   | 30   | 40   | 50   | 60   |
|-------|----|-----|-----|------|------|------|------|------|
| A     | mm | 600 | 900 | 1300 | 1300 | 1500 | 1600 | 1800 |
| B     | mm | 210 | 210 | 210  | 310  | 310  | 410  | 410  |
| C     |    | 460 | 460 | 460  | 460  | 460  | 480  | 480  |

### 2.1.5 SOUND ATTENUATOR SLR/SLM

It is used for the reduction of the fan noise through sound absorbing elements made from high density mineral wool, covered with anti-flaking film.

The following table shows the octave band [Hz] sound attenuation [dB].

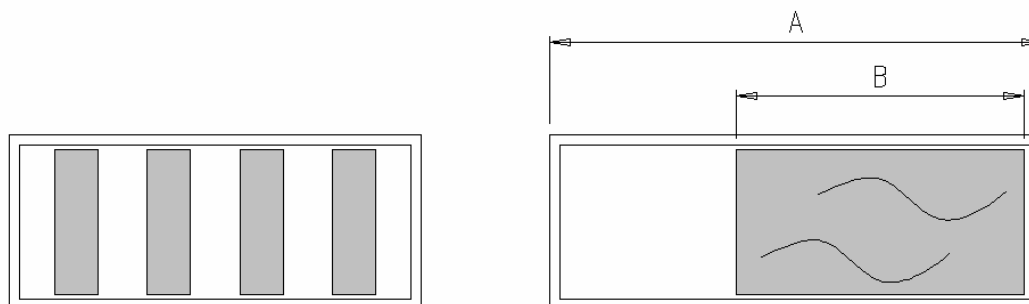

| Frequency [Hz]  |    | 63 | 125 | 250 | 500 | 1000 | 2000 | 4000 |
|-----------------|----|----|-----|-----|-----|------|------|------|
| Noise reduction | dB | 4  | 8   | 12  | 18  | 25   | 22   | 16   |

| MODEL |    | 10  | 20  | 25  | 30  | 40  | 50  | 60  |
|-------|----|-----|-----|-----|-----|-----|-----|-----|
| A     | mm | 850 | 850 | 850 | 850 | 850 | 960 | 960 |
| B     | mm | 500 | 500 | 500 | 500 | 500 | 500 | 500 |

### 2.1.6 SOFT BAG FILTER SECTION FTM

It takes F6 efficiency class (according to EN 779) soft bag filter made from synthetic media and galvanized steel frame; when selected, G3 basic unit prefilter passes into this section.

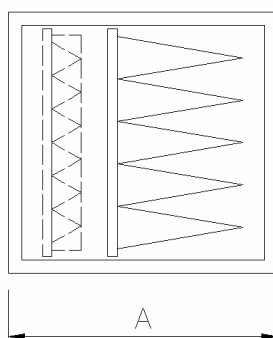

| MODEL                       |    | 10  | 20  | 25  | 30  | 40  | 50  | 60  |
|-----------------------------|----|-----|-----|-----|-----|-----|-----|-----|
| A                           | mm | 460 | 460 | 460 | 460 | 460 | 480 | 480 |
| N° filter cells 356x293x320 |    | 2   | 3   | 4   | 4   | 5   | 5   | 6   |

### 2.1.7 EVAPORATIVE PACK HUMIDIFIER UPA

This section includes a cellulose evaporative pack, impregnated with a water resistant resin, complete with a metal frame and water distributor in the upper part. The pack thickness is 100 mm and it is fed by not-recirculated water; the rated saturation efficiency is 70%. The section is also complete with plastic droplet eliminator.

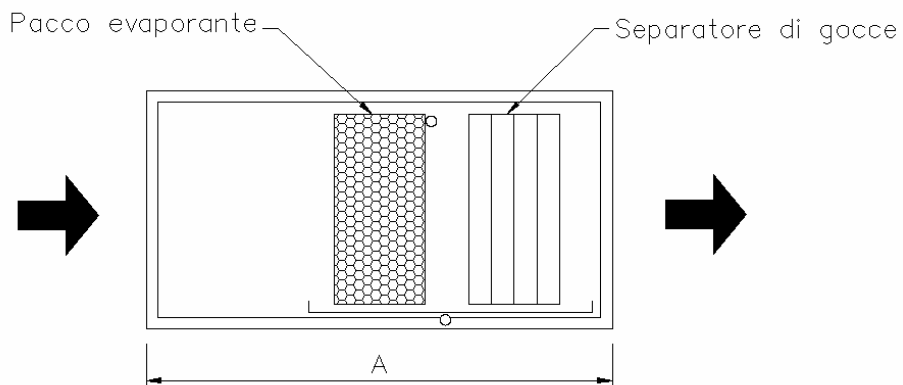

| MODEL |    | 10  | 20  | 25  | 30  | 40  | 50  | 60  |
|-------|----|-----|-----|-----|-----|-----|-----|-----|
| A     | mm | 850 | 850 | 850 | 850 | 850 | 960 | 960 |

### 2.1.8 PLENUM FOR STEAM DISTRIBUTOR UV

This section is prearranged for installing the steam distributor and includes the drain tray (steam generator and distributor excluded).

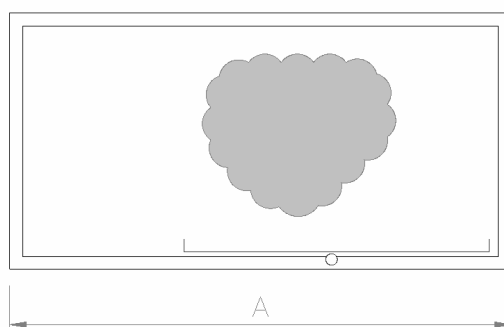

| MODEL |    | 10  | 20  | 25  | 30  | 40  | 50  | 60  |
|-------|----|-----|-----|-----|-----|-----|-----|-----|
| A     | mm | 850 | 850 | 850 | 850 | 850 | 960 | 960 |

### 2.1.9 WATER COIL RE-HEATING SECTION SRW

It contains a 2 row water coil whose capacity can be as per 1.4.1 paragraph.

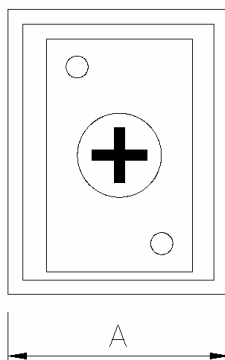

| MODEL |    | 10  | 20  | 25  | 30  | 40  | 50  | 60  |
|-------|----|-----|-----|-----|-----|-----|-----|-----|
| A     | mm | 460 | 460 | 460 | 460 | 460 | 480 | 480 |

### 2.1.10 ELECTRIC HEATER SECTION BRE

This section utilizes a series of armored electric resistors, assembled in 1, 2 or 3 stages, each of them complete with safety thermostat and relay inside the external electric control panel. The power supply is three-phase, 400 V – 50 Hz; the line protection must be carried out by the installer.

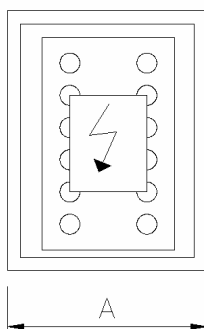

| MODEL |    | 10  | 20  | 25  | 30  | 40  | 50  | 60  |
|-------|----|-----|-----|-----|-----|-----|-----|-----|
| A     | mm | 460 | 460 | 460 | 460 | 460 | 480 | 480 |

| MODEL |          | 10 | 20 | 25   | 30   | 40   | 50   | 60   |      |
|-------|----------|----|----|------|------|------|------|------|------|
| 1 st  | Capacity | kW | 3  | 4,5  | 6,6  | 7,5  | 8,1  | 8,7  | 10,5 |
| 2 st  | Capacity | kW | 6  | 9    | 13,2 | 15   | 16,2 | 17,4 | 21   |
| 3 st  | Capacity | kW | 9  | 13,5 | 19,8 | 22,5 | 24,3 | 26,1 | 31,5 |

### 2.1.11 CIRCULAR DUCT CONNECTIONS SUPPLY ADAPTOR PCF

It allows the connection to circular air joints or ducts; the number and the dimensions of the connections are shown in the table as below.

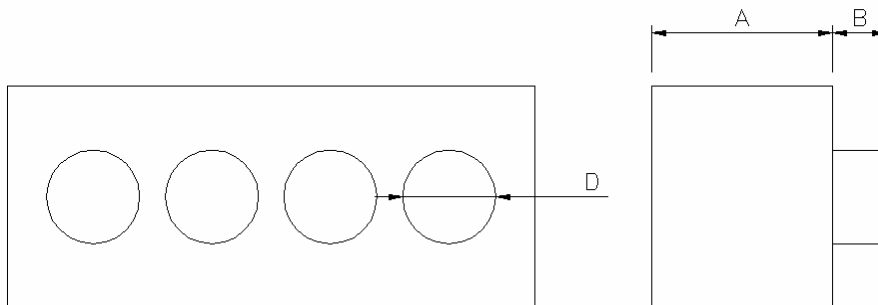

| MODEL |    | 10      | 20      | 25      | 30      | 40      | 50      | 60      |
|-------|----|---------|---------|---------|---------|---------|---------|---------|
| A     | mm | 460     | 460     | 460     | 460     | 460     | 480     | 480     |
| B     | mm | 100     | 100     | 100     | 100     | 100     | 100     | 100     |
| D     | mm | 200 x 2 | 200 x 4 | 250 x 4 | 250 x 4 | 315 x 4 | 315 x 4 | 315 x 5 |

### 2.1.12 SUPPLY PLENUM PMA

It can be used to calm the airflow coming out from the basic unit or to carry it by 90°; the outlet dimensions are for the possible installation of BMA supply grill.

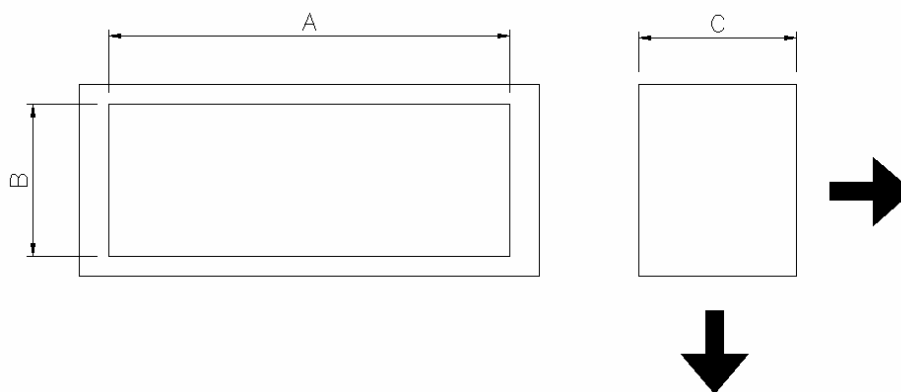

| MODEL |    | 10  | 20  | 25   | 30   | 40   | 50   | 60   |
|-------|----|-----|-----|------|------|------|------|------|
| A     | mm | 600 | 900 | 1300 | 1300 | 1500 | 1700 | 1900 |
| B     | mm | 200 | 200 | 200  | 300  | 300  | 400  | 400  |
| C     |    | 460 | 460 | 460  | 460  | 460  | 480  | 480  |



### 2.1.13 SUPPLY GRILL BMA

Applied on PMA plenum, it is useful for direct air diffusion to the room without air ducts; it has two rows of adjustable fins so that the airflow is adequately delivered.

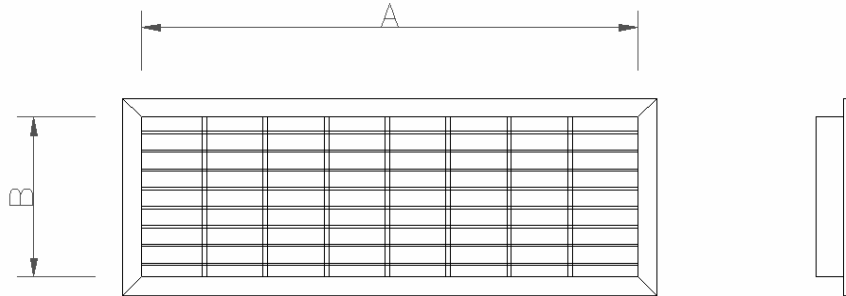

| MODEL    |    | 10  | 20  | 25   | 30   | 40   | 50   | 60   |
|----------|----|-----|-----|------|------|------|------|------|
| <b>A</b> | mm | 600 | 900 | 1300 | 1300 | 1500 | 1700 | 1900 |
| <b>B</b> | mm | 200 | 200 | 200  | 300  | 300  | 400  | 400  |

### 2.2 AIR PRESSURE DROPS

The following diagrams show, for each model, the air pressure drop of the selected accessories; the not cited accessories don't produce air pressure drop.

MiniAir 10

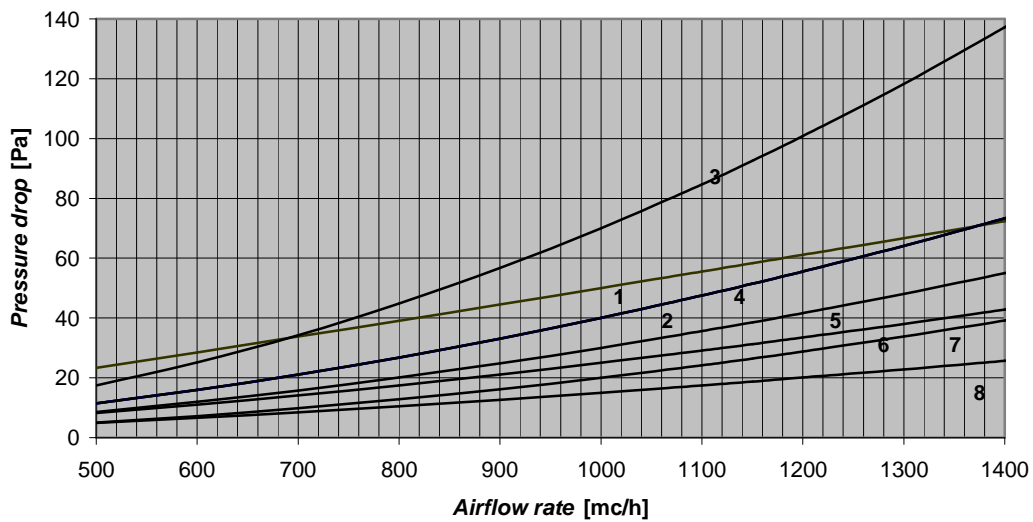

**MiniAir 20**

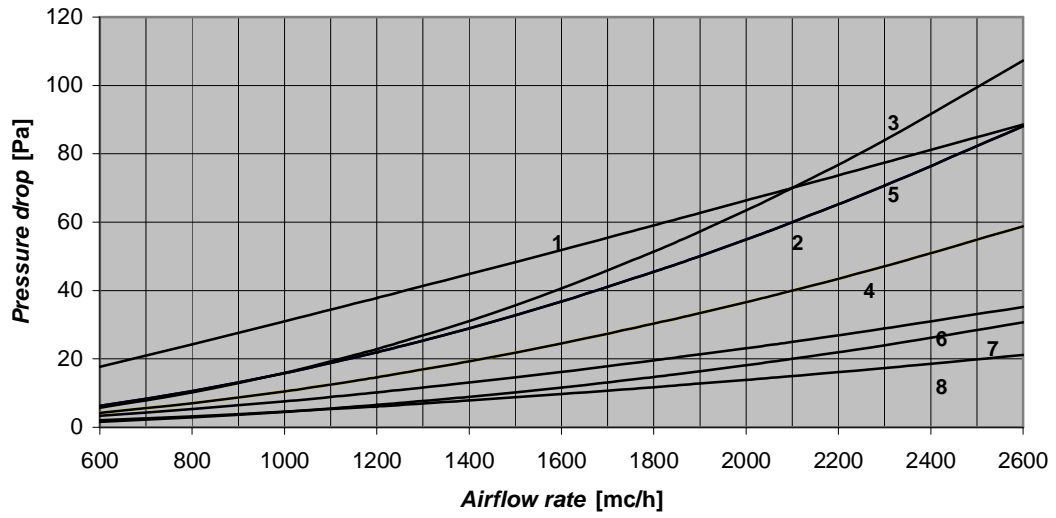

**MiniAir 25**

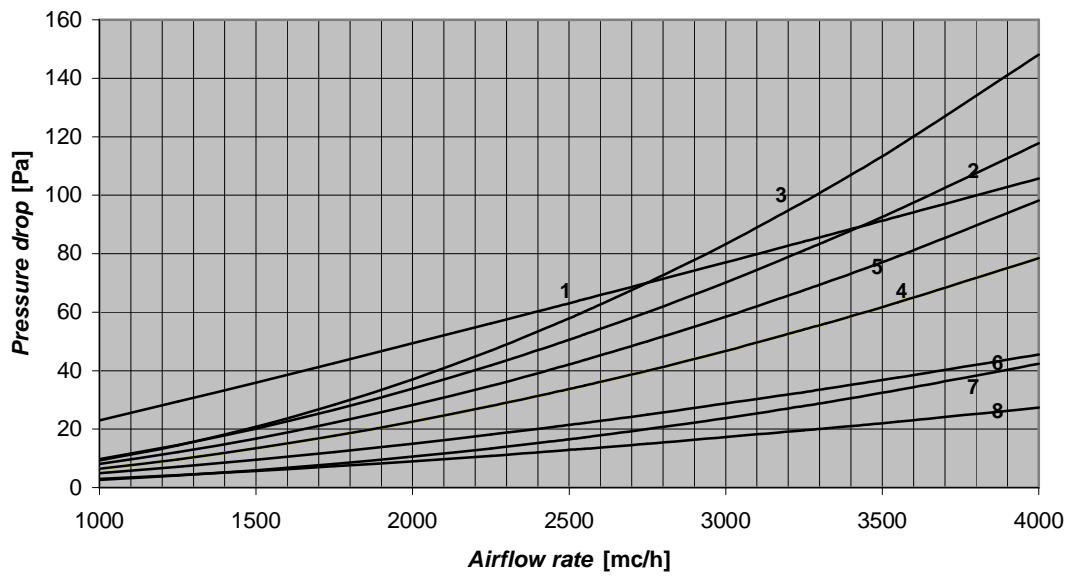

**MiniAir 30**

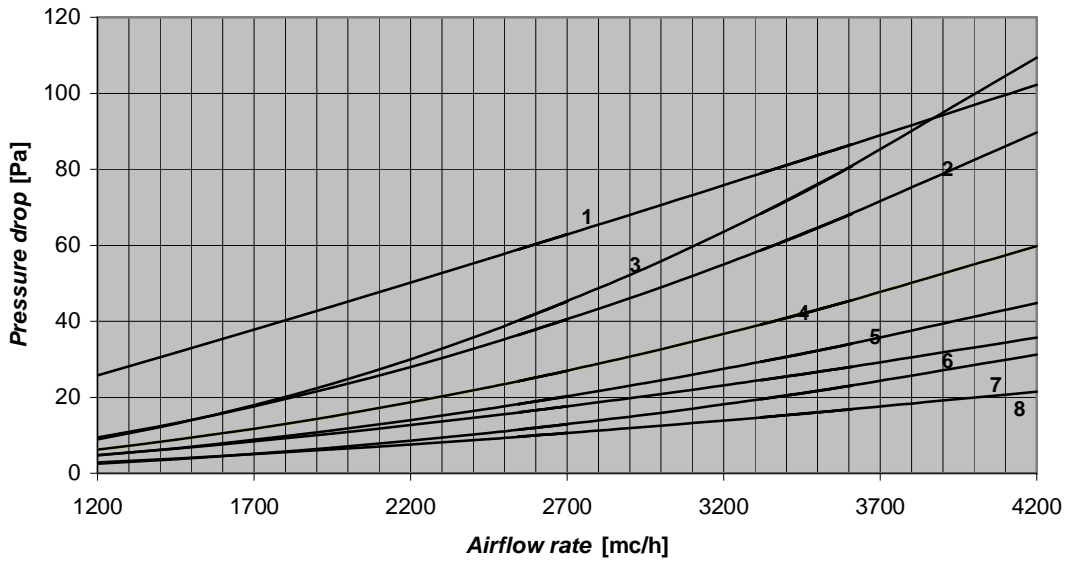

**MiniAir 40**

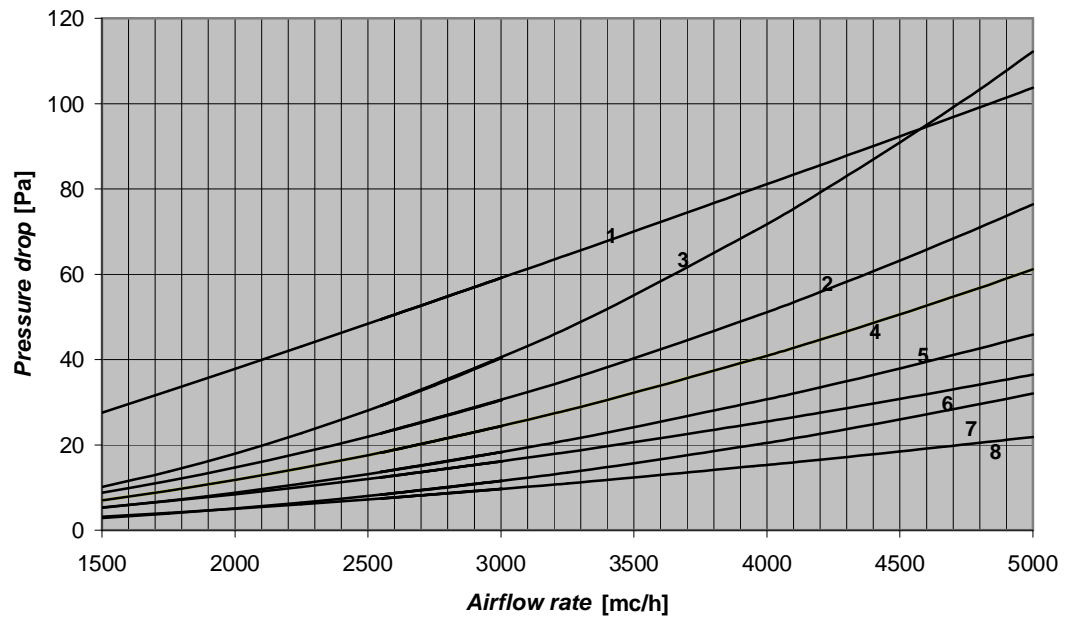

### MiniAir 50

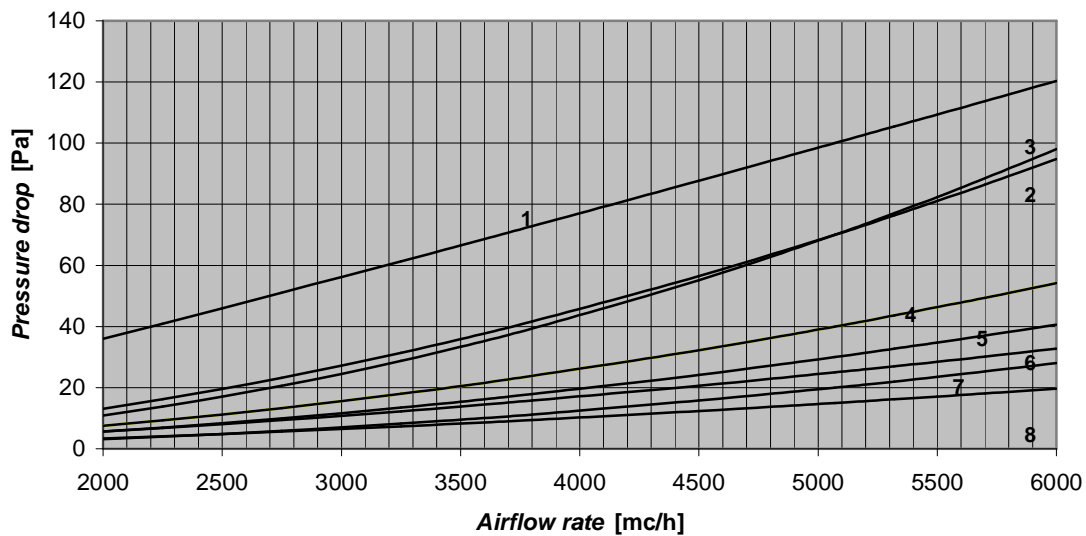

### MiniAir 60

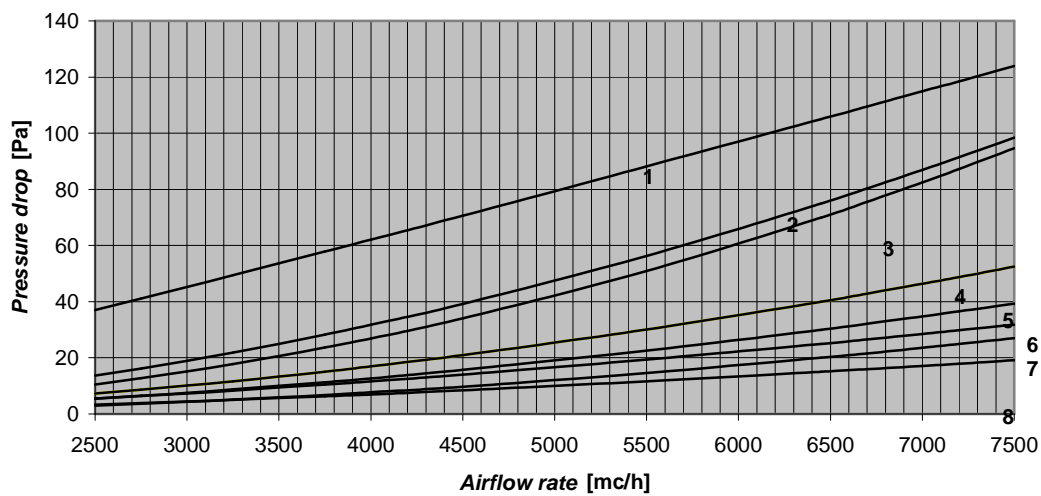

- 1 = FTM
- 2 = BMA
- 3 = UPA
- 4 = SLR/SLM/PCF
- 5 = GRA
- 6 = SRW
- 7 = PAR/PMA/CMS
- 8 = BRE (1 st.)

## SECTION 3 – ELECTRONIC CONTROL

### 3.1 ON/OFF CONTROL DEVICES

They mean the following control devices whose specific technical features are given together the supplied unit and their selected accessories :

- **CVU** : 3 step fan speed control (min/med/max)
- **PCU** : control panel with 3 step fan speed control, winter/summer switch, room thermostat (remote 4,7 k $\Omega$  NTC sensor as an option), heating/cooling water coil control
- **PCUR** : like PCU with electric heater on/off control
- **V3/S230** : 3 way water valve complete with 230 V servocontrol and join tubing
- **SSE** : 230 V on/off damper servocontrol with spring back
- **HAS** : room hygostat
- **HCS** : duct hygostat
- **VS** : water humidifier 230 V solenoid valve
- **PSTD** : air filter pressure switch

### 3.2 MODULATING CONTROL DEVICES

They mean a water valve kit and an electronic control kit, complete with electrical board; the specific technical features are given together the supplied unit.

#### Water valve kit

- **V3P2 $\underline{x}$**  : 3 way water valve for  $\underline{x}$  row coil complete with modulating servocontrol (24 V power supply, 0÷10 V control signal) and join tubing

#### Electronic control kit

- **RQ** : temperature analogical controller complete with n°3 NTC sensors and electrical board

#### Services

- Heating/cooling/free-cooling mode
- Winter/summer mode (by parameter setting)
- Antifreeze mode
- Electric heater on/off mode
- Manual or automatic fan speed selection (also by air quality sensor control signal)
- Dirty filter alarm (by PSTD)
- Chronothermostat
- Missing ventilation alarm (prearrangement)
- Building Management System (prearrangement; select TNET accessory)

## SECTION 4 – UNIT IDENTIFICATION

For the correct identification of the unit and their selected accessories it must be specified when ordering:

- the version (MINIAIR42 for example)
- the model (30 for example)
- the accessories (SLR and PMA for example)

So, the complete order will be :

**MINIAIR42 30 SLM PMA**

## SECTION 1 – TECHNICAL FEATURES

### 1.1 GENERAL FEATURES

- Aluzink frame
- Fully removable Aluzink panels
- Rockwool thermal and acoustic insulation; thickness 10 mm (up to 10 size), 20 mm (for upper sizes)
- High efficiency crossflow heat recovery, aluminium heat exchanger plates with supplementary sealing; stainless steel drain tray, extended to all the cooling/heating components and heat insulated and fitted with ½” GAS female threaded bottom outlet
- G3 efficiency class synthetic cell filters, positioned on suction sections, easily removable from side or bottom
- Multi-speed direct driven double inlet forward curved fans, eventually supplied with built-in frequency converter motors; fan groups mounted on anti-vibrators
- External terminal block with a relay board to aid the electrical connections and fan speed control.

### 1.2 UNIT DIMENSIONS

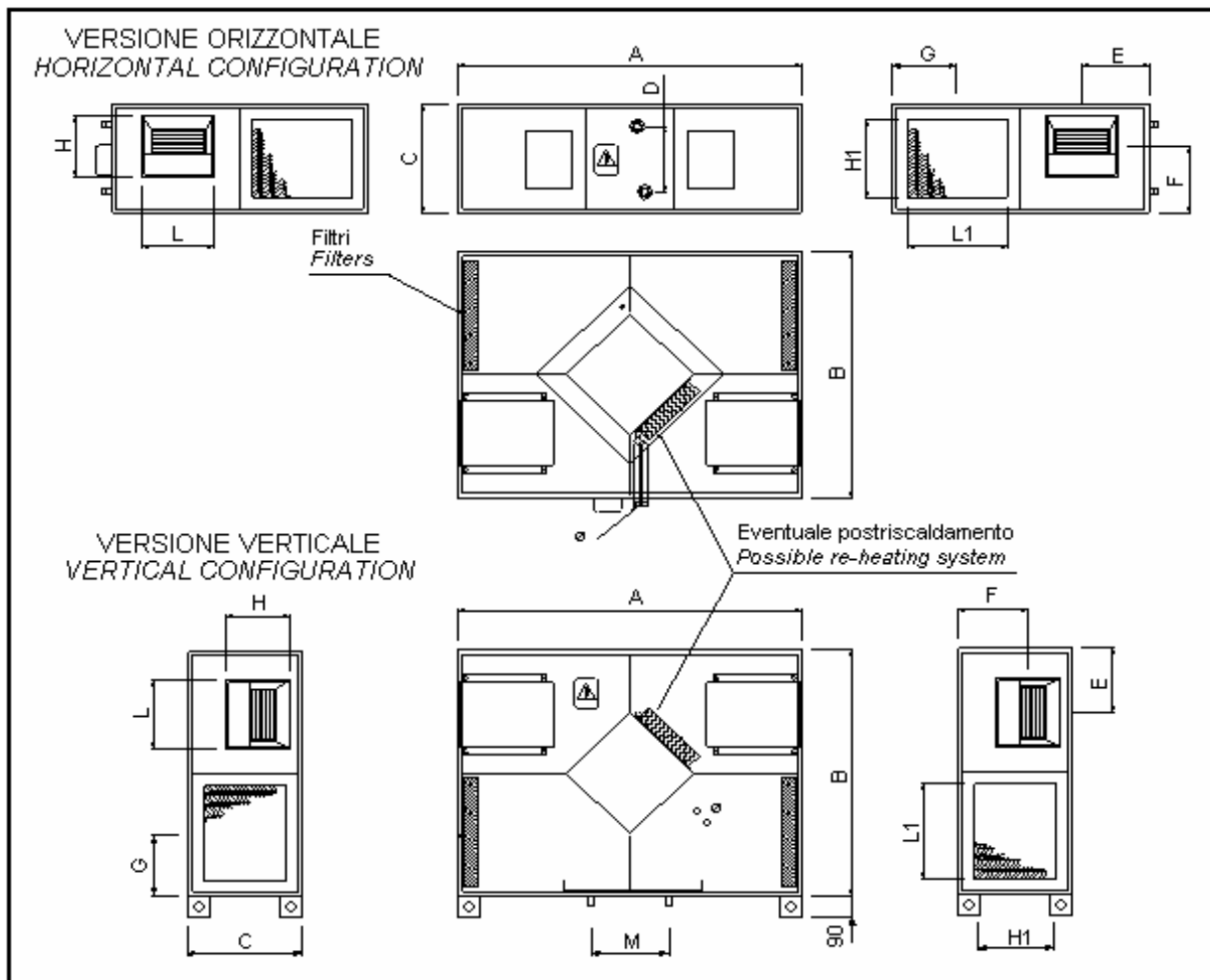

| MODEL  |    | MINIAIR+<br>03 | MINIAIR+<br>06 | MINIAIR+<br>10 | MINIAIR+<br>14 | MINIAIR+<br>19 | MINIAIR+<br>25 | MINIAIR+<br>30 | MINIAIR+<br>40 |
|--------|----|----------------|----------------|----------------|----------------|----------------|----------------|----------------|----------------|
| A      | mm | 990            | 990            | 1150           | 1300           | 1450           | 1700           | 1700           | 1700           |
| B      | mm | 750            | 750            | 860            | 900            | 900            | 1230           | 1230           | 1230           |
| C      | mm | 270            | 270            | 385            | 410            | 470            | 490            | 530            | 630            |
| D      | mm | -              | -              | 230            | 230            | 280            | 305            | 305            | 405            |
| L      | mm | 127            | 164            | 240            | 240            | 240            | 306            | 339            | 339            |
| H      | mm | 108            | 100            | 218            | 270            | 270            | 270            | 297            | 297            |
| L1     | mm | 275            | 275            | 330            | 337            | 337            | 502            | 502            | 502            |
| H1     | mm | 153            | 153            | 267            | 267            | 327            | 347            | 387            | 487            |
| E      | mm | 120            | 197            | 225            | 241            | 230            | 323            | 308            | 308            |
| F      | mm | 135            | 171            | 238            | 224            | 284            | 304            | 331            | 431            |
| G      | mm | 197            | 197            | 225            | 241            | 241            | 323            | 323            | 323            |
| M      | mm | 100            | 100            | 100            | 100            | 145            | 100            | 100            | 100            |
| φ      |    | -              | -              | G 3/4          | G 3/4          | G 3/4          | G 3/4          | G 3/4          | G 3/4          |
| Weight | kg | 39             | 41             | 68             | 91             | 99             | 140            | 155            | 179            |

### 1.3 TECHNICAL DATA AND PERFORMANCES

| Aeraulic performances (*) |                   |             |             |             |             |             |             |             |             |
|---------------------------|-------------------|-------------|-------------|-------------|-------------|-------------|-------------|-------------|-------------|
| MODEL                     |                   | MINIAIR+ 03 | MINIAIR+ 06 | MINIAIR+ 10 | MINIAIR+ 14 | MINIAIR+ 19 | MINIAIR+ 25 | MINIAIR+ 30 | MINIAIR+ 40 |
| Airflow rate              | m <sup>3</sup> /h | 290         | 550         | 1000        | 1400        | 1900        | 2500        | 3200        | 4000        |
| E.S.P.                    | Pa                | 60          | 65          | 90          | 140         | 120         | 110         | 170         | 170         |
| Sound level               | dB(A)             | 53          | 54          | 53          | 60          | 59          | 56          | 59          | 62          |

(\*) at fan max speed; sound level at 1 m far from the unit

| Fan electrical features |    |                  |             |             |             |             |             |             |             |
|-------------------------|----|------------------|-------------|-------------|-------------|-------------|-------------|-------------|-------------|
| MODEL                   |    | MINIAIR+ 03      | MINIAIR+ 06 | MINIAIR+ 10 | MINIAIR+ 14 | MINIAIR+ 19 | MINIAIR+ 25 | MINIAIR+ 30 | MINIAIR+ 40 |
| Motor power             | W  | 2 x 45           | 2 x 65      | 2 x 147     | 2 x 350     | 2 x 350     | 2 x 350     | 2 x 550     | 2 x 750     |
| Current                 | A  | 1,3              | 1,6         | 3           | 5,8         | 6,2         | 6           | 11,4        | 6,2         |
| Fan speeds              |    | 2                | 2           | 3           | 3           | 3           | 3           | 3           | 2           |
| Protection degree       | IP | Min 20           |             |             |             |             |             |             |             |
| Temperat. class         |    | Min. B           |             |             |             |             |             |             |             |
| Power supply            |    | 230 V/1 ph/50 Hz |             |             |             |             |             |             | 400/3/50    |

| Heat recovery performances (**) |    |             |             |             |             |             |             |             |             |
|---------------------------------|----|-------------|-------------|-------------|-------------|-------------|-------------|-------------|-------------|
| MODEL                           |    | MINIAIR+ 03 | MINIAIR+ 06 | MINIAIR+ 10 | MINIAIR+ 14 | MINIAIR+ 19 | MINIAIR+ 25 | MINIAIR+ 30 | MINIAIR+ 40 |
| Efficiency                      | %  | 52,3        | 54,9        | 53,4        | 52,1        | 51,8        | 57,6        | 56,0        | 55,6        |
| Heat capacity                   | kW | 1,4         | 2,8         | 4,6         | 6,2         | 8,4         | 12,3        | 15,3        | 19,4        |

(\*\*) at fan max speed; outside air temperature -5°C 80% RH, room air temperature 20°C 50% RH

### 1.4 POSSIBLE ORIENTATIONS

According to the air duct lay-out, it is possible to rotate adequately the MINIAIR+ unit air inlets and outlets to give the following combinations, each of them is a specific unit orientation to be specified when ordering:

#### Horizontal configuration

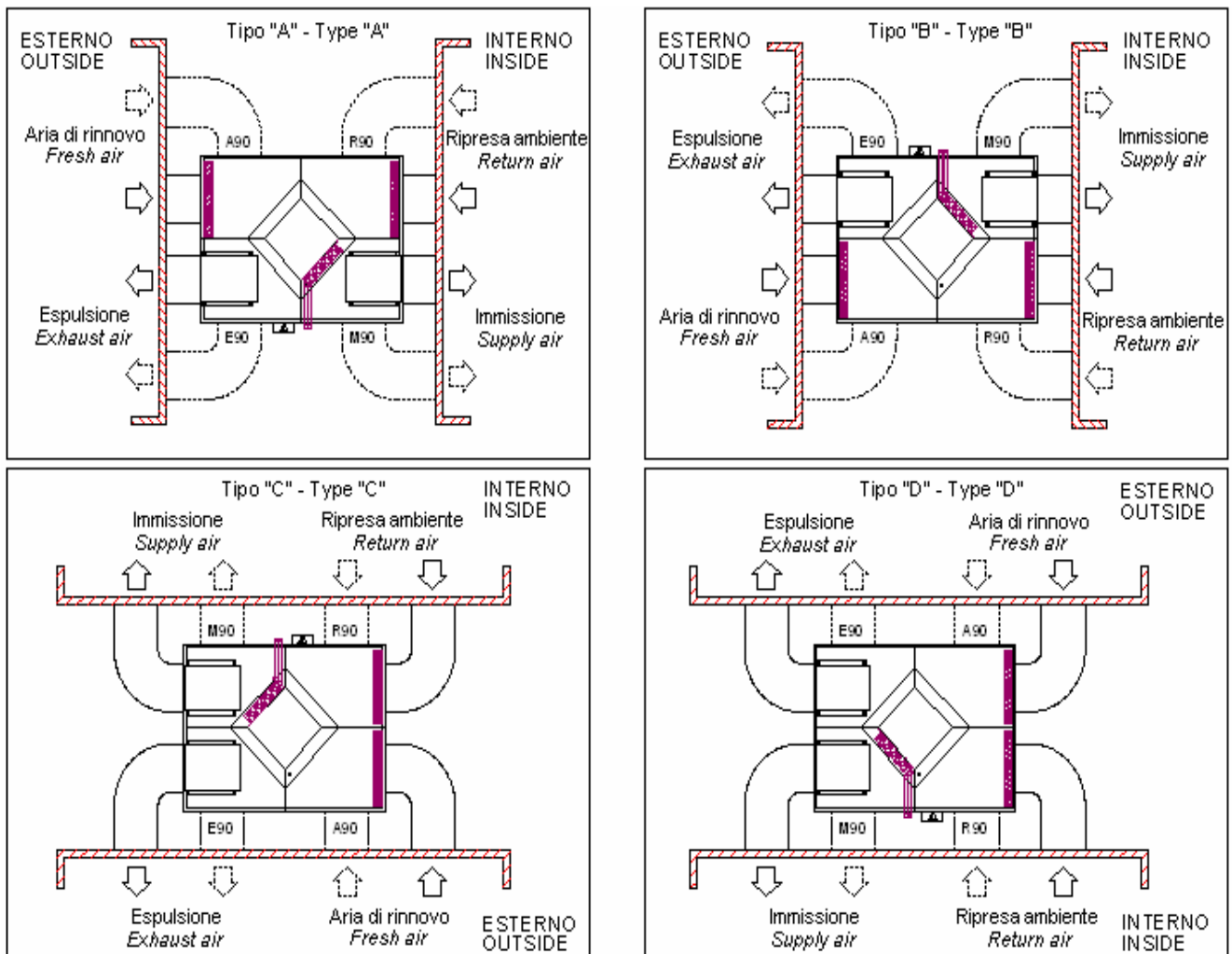

Vertical configuration (also with re-heating system)

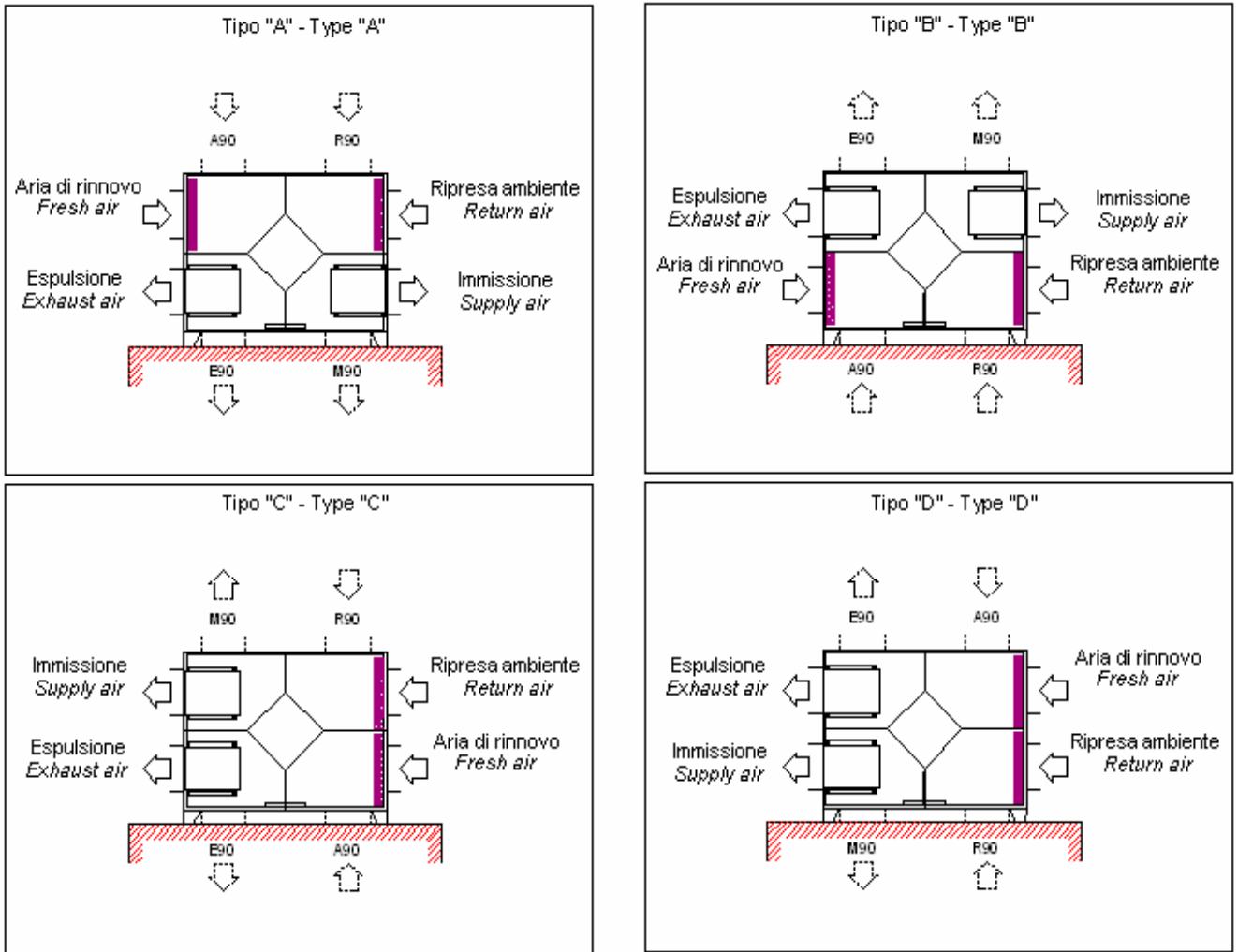

To modify the position of the suction inlets it is sufficient to exchange two panels each other, as shown in the figure below.

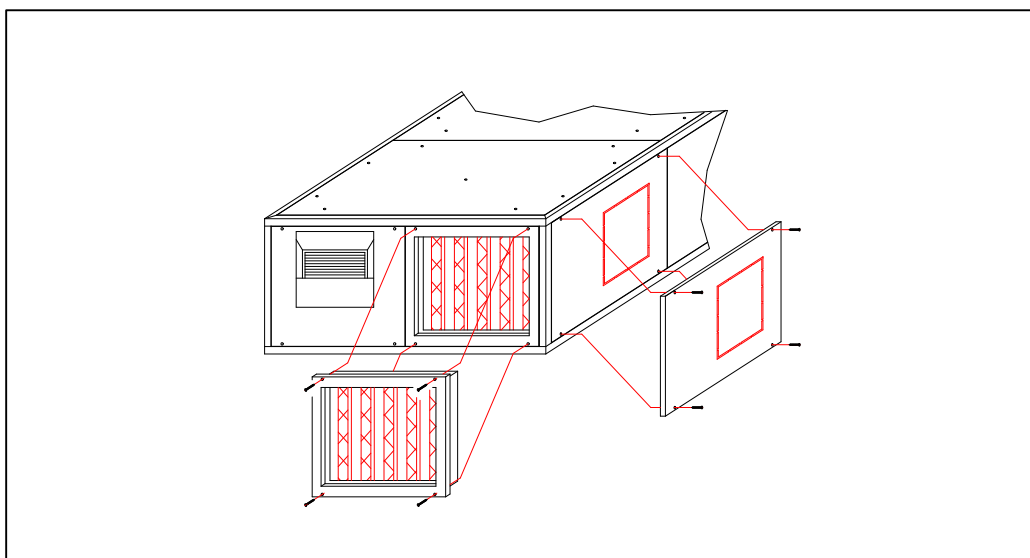



## SECTION 2 – ACCESSORIES

### 2.1 ACCESSORIES

MINIAIR+ units can be supplied with a complete series of accessories, selected for facilitating and completing the installation, the air treatments and the unit control; they are :

- Electric heater **SKE**
- Re-heating internal water coil **SKW**
- Water cooling ducted section **SAF**
- Adjusting damper **SKR**
- 3-way mixing box **MS3**
- F6 soft bag filter **FTK**
- Built-in inverter motors **DDE**
- Fan speed control **CVU**
- Unit control panel **PCU/PCUR**
- Air filter pressure switch **PSTD**
- Antifreeze thermostat **TEG**
- On/off damper servo control **SSE**
- Circular duct connection (one piece) **BCC**
- Flexible duct joint (one piece) **GAT**
- 3 way on/off water valve (one set) **V3/S230**
- Roof cover **TPR**
- Modulating control devices

### 2.2 ELECTRIC HEATER

#### SKE

It takes place inside MINIAIR+ unit as preheater or reheater or both in the fresh air circuit, as defrost system in the return circuit.

It is made from modular electric heating elements which are able to supply the power as in the table 2.2.1; it is complete of control relay and safety thermostat, while power line protection must be carried out by the installer.

#### 2.2.1 SKE technical features

| MODEL             |    | 03               | 06   | 10  | 14               | 19   | 25   | 30   | 40   |
|-------------------|----|------------------|------|-----|------------------|------|------|------|------|
| Power             | kW | 2                | 4    | 4,5 | 6                | 9    | 12   | 12   | 12   |
| Power supply      |    | 230 V/1 ph/50 Hz |      |     | 400 V/3 ph/50 Hz |      |      |      |      |
| Current           | A  | 8,7              | 17,4 | 6,5 | 8,7              | 13,0 | 17,3 | 17,3 | 17,3 |
| Air pressure drop | Pa | 5                | 5    | 6   | 6                | 8    | 6    | 9    | 13   |
| Weight            | kg | 2                | 2    | 3   | 3                | 3    | 3    | 3    | 3    |

### 2.3 RE-HEATING WATER COIL

#### SKW

It takes place inside MINIAIR+ unit after the heat recovery in the supply circuit and it is useful as a hot water reheater to avoid too low supply temperature. It's not suitable for cooling working mode (see the following 2.4).

The table as below gives the heater performance at the nominal airflow rate and at the specified conditions; for different working conditions and for different airflow rates, the updated heating performance can be valued by the specific LENNOX selection software (contact LENNOX Sales Department) :

| MODEL                          |     | 03   | 06 | 10   | 14   | 19   | 25   | 30   | 40   |
|--------------------------------|-----|--|----|------|------|------|------|------|------|
| Heat capacity                  | KW  | non disponibile<br><br><i>not available</i><br>(*) |    | 11,3 | 16,3 | 20,4 | 29,7 | 35,1 | 44,3 |
| Supply temperat.               | °C  |  |    | 40,5 | 41,5 | 39,0 | 42,2 | 39,6 | 39,9 |
| Air pressure drop              | Pa  |  |    | 65   | 64   | 85   | 62   | 85   | 92   |
| H <sub>2</sub> O pressure drop | kPa |  |    | 13   | 31   | 18   | 20   | 27   | 49   |
| Weight                         | kg  |  |    | 3    | 3    | 3    | 6    | 6    | 8    |

Inlet air temperature 8°C, in/out water temperature 70/60°C

(\*) Eventually use SAF ducted section supplied with hot water or SKE electric heater

## 2.4 COOLING SECTION

### SAF

It's an insulated box with a coil inside and takes place between the MINIAIR+ unit and the supply duct, useful as an air cooler, even suitable as a reheater; the condensate outlet (1/2" GAS female threaded) is on the bottom through a stainless steel drain tray.

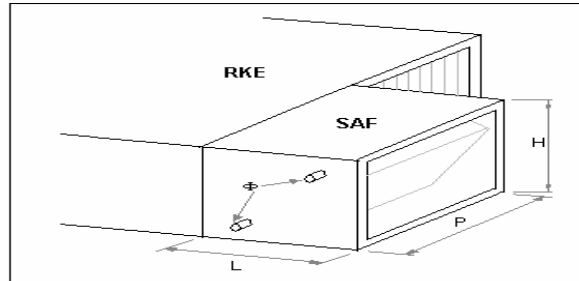

| MODEL                          |     | 03  | 06  | 10  | 14  | 19   | 25   | 30   | 40   |
|--------------------------------|-----|-----|-----|-----|-----|------|------|------|------|
| Cooling capacity               | KW  | 2,5 | 3,8 | 6,5 | 9,6 | 13,1 | 18,1 | 21,2 | 28,1 |
| Air pressure drop              | Pa  | 23  | 67  | 79  | 87  | 96   | 70   | 105  | 96   |
| H <sub>2</sub> O pressure drop | kPa | 9   | 11  | 12  | 25  | 32   | 18   | 24   | 41   |
| Width P                        | mm  | 375 | 375 | 430 | 450 | 450  | 615  | 615  | 615  |
| Length L                       | mm  | 400 | 400 | 700 | 700 | 700  | 700  | 800  | 800  |
| Height H                       | mm  | 270 | 270 | 385 | 410 | 470  | 490  | 630  | 630  |
| Connection $\phi$              | mm  | 16  | 16  | 18  | 22  | 28   | 35   | 42   | 42   |
| Weight                         | kg  | 9   | 9   | 17  | 20  | 21   | 25   | 30   | 30   |

Inlet air condition 29°C 60% RH, in/out water temperature 7/12°C, nominal airflow rate

## 2.5 ADJUSTING DAMPER

### SKR

It is necessary when air duct pressure drops must meet with external static pressure of supply and return fans. It is made from aluminium frame and aluminium contrasted paddles, controlled by handle lever or electrical servocontrol (not supplied).

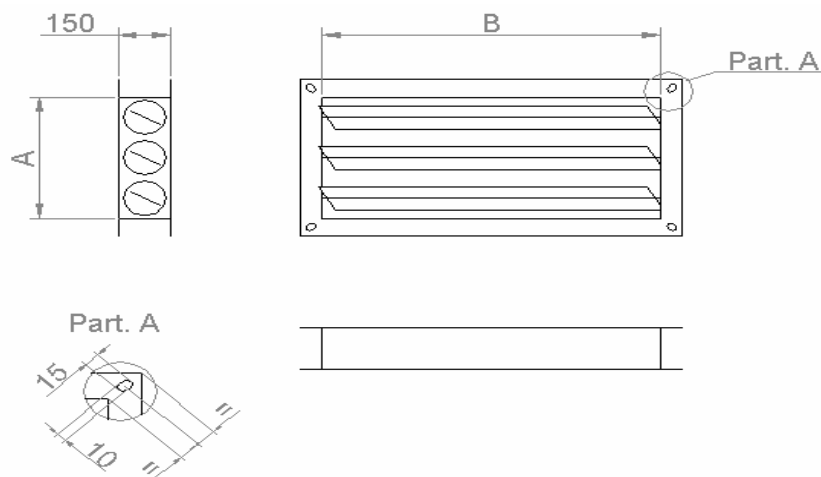

| MODEL  |    | 03  | 06  | 10  | 14  | 19  | 25  | 30  | 40  |
|--------|----|-----|-----|-----|-----|-----|-----|-----|-----|
| A      | mm | 210 | 210 | 310 | 310 | 410 | 410 | 410 | 510 |
| B      | mm | 280 | 280 | 330 | 330 | 330 | 500 | 500 | 500 |
| Weight | kg | 2,5 | 2,5 | 3,5 | 3,5 | 4   | 5   | 5   | 6   |

Moreover, if two dampers are used in the return/exhaust air circuit as shown in the figure, it is possible to have an external heat recovery by-pass system, allowing the free-cooling unit working mode.

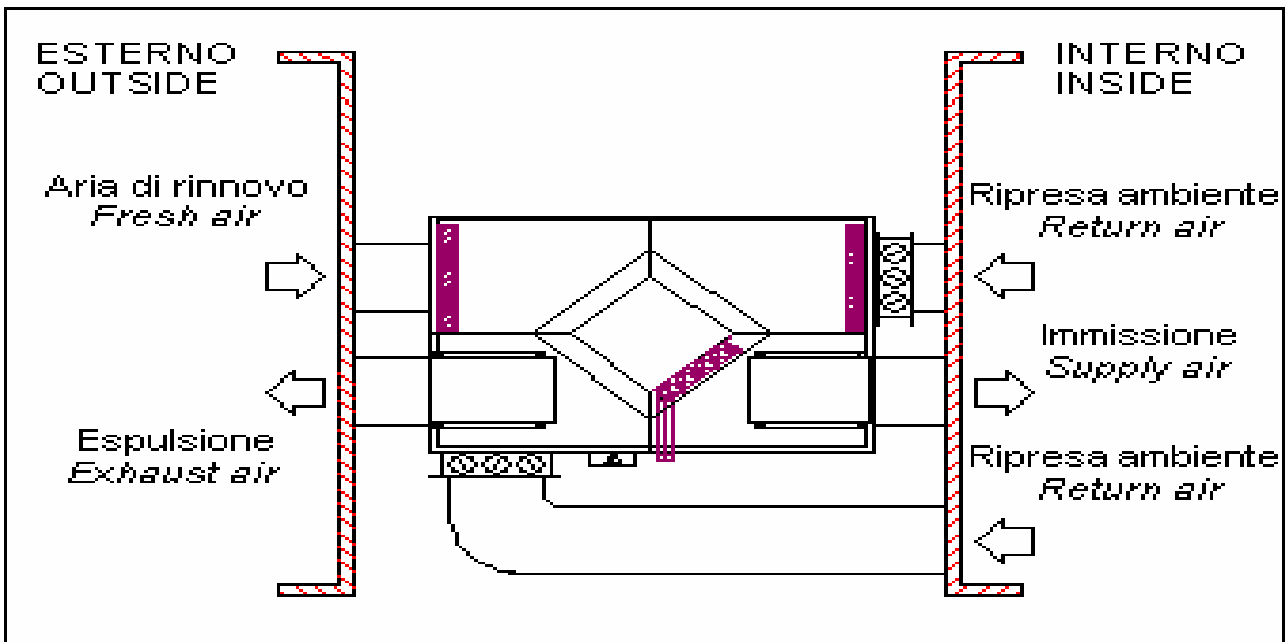

### 2.6 3-WAY MIXING BOX MS3

It can be used when recirculation working mode is needed, for example, for speeding-up the room temperature or for defrosting the recovery pack.

Each of the three dampers can be controlled by an own servocontrol or all the three dampers by one servocontrol via a lever system (LCS accessory).

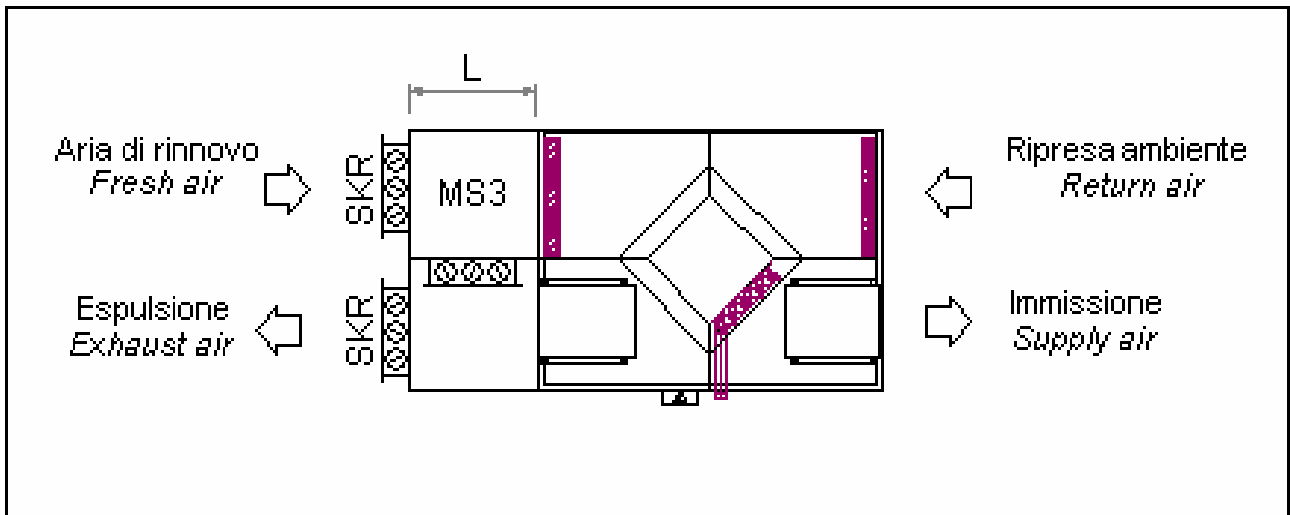

| MODEL  |    | 03              | 06 | 10  | 14  | 19  | 25  | 30  | 40  |
|--------|----|-----------------|----|-----|-----|-----|-----|-----|-----|
| L      | mm | non disponibile |    | 400 | 400 | 500 | 600 | 600 | 600 |
| Weight | kg | not available   |    | 47  | 59  | 66  | 90  | 99  | 121 |

## 2.7 SOFT BAG FILTER

### FTK

Available from 14 model, it increases the unit filtering capacity. Made from synthetic material, it is put inside the unit, in the same frame of the G3 prefilter.

| MODEL                 |    | 03                   | 06 | 10 | 14  | 19  | 25  | 30  | 40  |
|-----------------------|----|----------------------|----|----|-----|-----|-----|-----|-----|
| Air pressure drop (*) | Pa | non disponibile      |    |    | 140 | 160 | 160 | 160 | 180 |
| Weight                | kg | <i>not available</i> |    |    | 1   | 1   | 1,5 | 2   | 2,5 |

(\*) *At nominal airflow rate*

## 2.8 BUILT-IN INVERTER MOTORS

### DDE

When controlled changing or automatic preservation of nominal airflow rate is required while air pressure drops are changing, it is possible to use fan-motors equipped with integrated frequency regulation.

The control is made by 0÷5V analog input signal; the relation between frequency (speed) motor and analog control signal is proportional type, depending on frequency range selected (by dip-switch) and analog control signal type; when frequency is less than 10% nominal range frequency, motor is off:

| Input signal | $X_{max}$ | $X_0$ | K                     |
|--------------|-----------|-------|-----------------------|
| 0 ÷ 5 [V]    | 5 [V]     | 0 [V] | 0,22 $F_{nom}$ [Hz/V] |

Independently from unit size, DDE motor power supply is single phase 230 V.

DDE fan-motors have protection functions as:

- Undervoltage protection
- Overcurrent and overload protection
- Safety thermal hardware protection
- Blocked rotor condition control

## 2.9 FAN SPEED CONTROL

### CVU

Suitable for wall installation, it allows to select one of the possible fan speeds.

On the control panel there are :

- on/off switch
- 3 position speed switch

#### 2.9.1 Technical features

|                          |                            |
|--------------------------|----------------------------|
| Power supply             | 230 ± 10% Vac 50/60 Hz     |
| Temperature limits       | -10°C ÷ 50°C               |
| Relative humidity limits | 10 ÷ 90 % without condens. |
| Protection degree        | IP 20                      |

## 2.10 UNIT CONTROL PANEL PCU/PCUR

Suitable for wall installation, it allows to control the room temperature (on/off control) both in summer and winter mode and to select the fan speed; the temperature sensor can be eventually far from the wall panel.

On the control panel there are :

- on/off and S/W switch
- 3 position speed switch
- temperature control knob
- electric heater on/off control (only by PCUR)

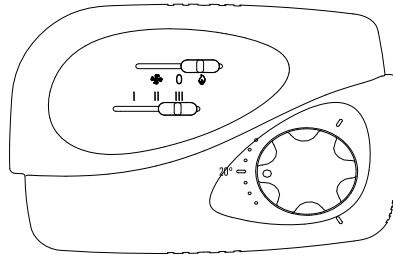

### 2.10.1 Technical features

|                                 |                            |
|---------------------------------|----------------------------|
| <b>Power supply</b>             | 230 ± 10% Vac 50/60 Hz     |
| <b>Temperature range</b>        | 6°C ÷ 30°C                 |
| <b>Temperature sensor</b>       | NTC 4,7 kΩ                 |
| <b>Temperature differential</b> | 0,5°C ± 0,1°C              |
| <b>Temperature limits</b>       | 0°C ÷ 50°C                 |
| <b>Relative humidity limits</b> | 20 ÷ 90 % without condens. |
| <b>Protection degree</b>        | IP 20                      |

## 2.11 AIR FILTER PRESSURE SWITCH PSTD

It is suitable for control of air filter dirt condition, by acting on an electrical circuit when set-point pressure value is achieved.

## 2.12 ANTIFREEZE THERMOSTAT TEG

It can be used everywhere temperature must not drop below a certain fixed safety value.

### 2.12.1 Technical features

|                                 |                           |
|---------------------------------|---------------------------|
| <b>Power supply</b>             | 250 Vac 50/60 Hz          |
| <b>Temperature range</b>        | -10°C ÷ 12°C              |
| <b>Capillary length</b>         | 1,8 m                     |
| <b>Reset</b>                    | automatic                 |
| <b>Temperature limits</b>       | -20°C ÷ 80°C              |
| <b>Relative humidity limits</b> | 0 ÷ 95 % without condens. |
| <b>Protection degree</b>        | IP 54                     |

## 2.13 ON/OFF DAMPER SERVOCONTROL SSE

It is suitable for damper control; the power supply is 230 V single phase. It is fitted with automatic spring back.

## 2.14 CIRCULAR DUCT CONNECTION BCC

It allows the connection between the unit and the air plant fitted with circular joints or ducts; it can be installed both on the air inlets and outlets.

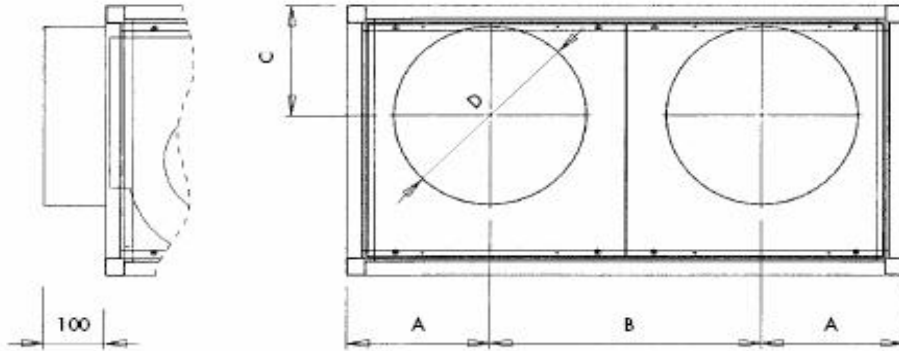

| MODEL |    | 03  | 06  | 10  | 14  | 19  | 25  | 30  | 40  |
|-------|----|-----|-----|-----|-----|-----|-----|-----|-----|
| A     | mm | 114 | 197 | 224 | 241 | 230 | 323 | 307 | 307 |
| B     | mm | 522 | 356 | 411 | 418 | 440 | 583 | 616 | 616 |
| C     | mm | 135 | 133 | 194 | 208 | 208 | 228 | 250 | 275 |
| D     | mm | 156 | 196 | 312 | 312 | 312 | 351 | 396 | 446 |

## 2.15 FLEXIBLE DUCT JOINT GAT

It allows the flexible connection between the unit and the air ducts, to cut off the transmission of the mechanical vibrations due to the mobile parts of the unit. For the dimensions, see the SKR dimensions for the considered MINIAIR+ model.

## 2.16 3 WAY ON/OFF WATER VALVE V3/S230

Combined with PCU/PCUR control panel and suitable for SKW and SAF control, the set is composed of a 3-way valve, on/off 230 V servomotor and copper connectors to the coil headers.

| MODEL                           | 03 | 06  | 10 | 14 | 19  | 25 | 30 | 40 |
|---------------------------------|----|---|----|----|---|----|----|----|
| Water connection<br>(SKW & SAF) |    | $\frac{1}{2}$ " GAS femmina<br>$\frac{1}{2}$ " GAS female |    |    | $\frac{3}{4}$ " GAS femmina<br>$\frac{3}{4}$ " GAS female |    |    |    |

## 2.17 ROOF COVER TPR

The Aluzink roof cover is to be used when RFM unit is installed outdoor; however, it is recommended to install the unit in suitable, indoor and easily accessible places possibly.

## 2.18 MODULATING CONTROL DEVICES

They mean a water valve kit and an electronic control kit, complete with electrical board; the specific technical features are given together the supplied unit.

### **Water valve kit**

- **V3P2** : 3 way water valve complete with modulating servocontrol (24 V power supply, 0÷10 V control signal) and join tubing (for SKW or SAF)
- **V3P4** : n°02 3 way water valves each of them complete with modulating servocontrol (24 V power supply, 0÷10 V control signal) and join tubing (for SKW and SAF)

### **Electronic control kit**

**RQ** : temperature analogical controller complete with n°3 NTC sensors and electrical board

### Electronic control services

1. Heating/cooling/free-cooling mode
2. Antifreeze mode
3. Electric heater on/off mode
4. Winter room temperature speeding up
5. Heat recovery defrost mode
6. Fan speed manual or automatic control (also via air quality sensor signal)
7. Dirty filter alarm (via PSTD)
8. Lost ventilation alarm (via pressare switch signal)
9. Clock
10. Building Management System (prearrangement; select TNET accessory)

### SECTION 3 – AIR PERFORMANCES

The following curves are, model by model, the external static pressure of the basic unit (G3 filter + heat recovery) while changing the airflow rate and the fan speed.

#### MINIAIR+ 03

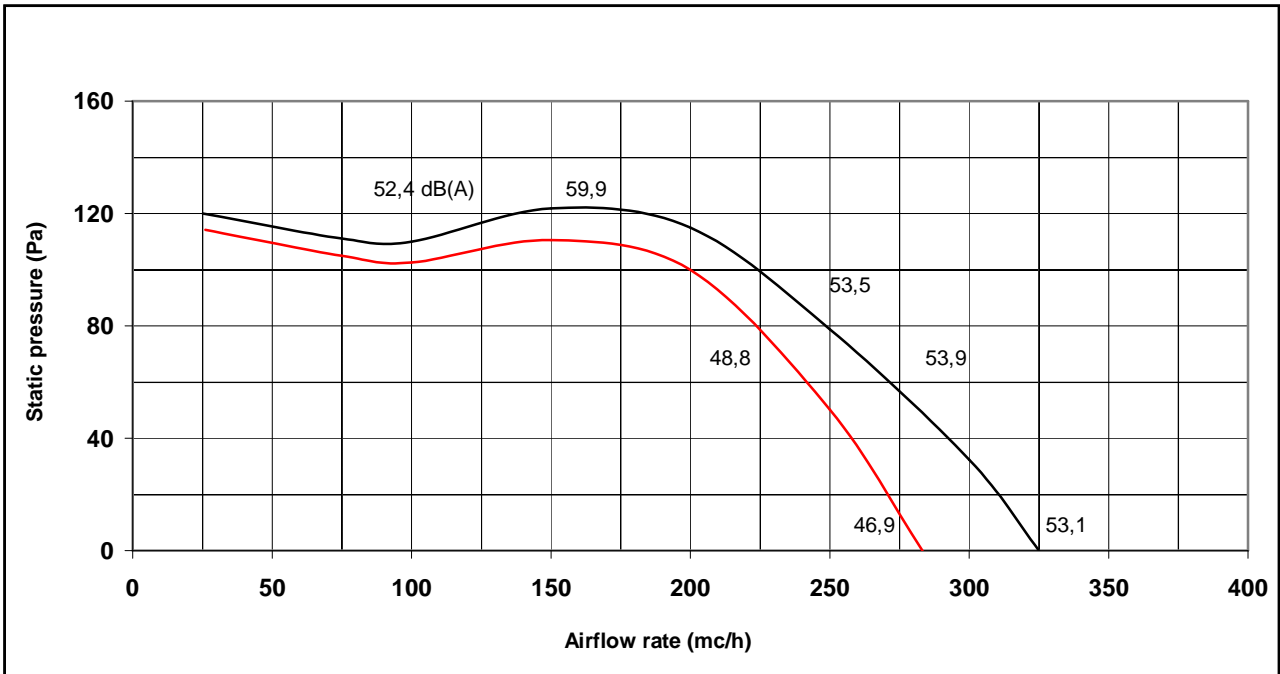

#### MINIAIR+ 06

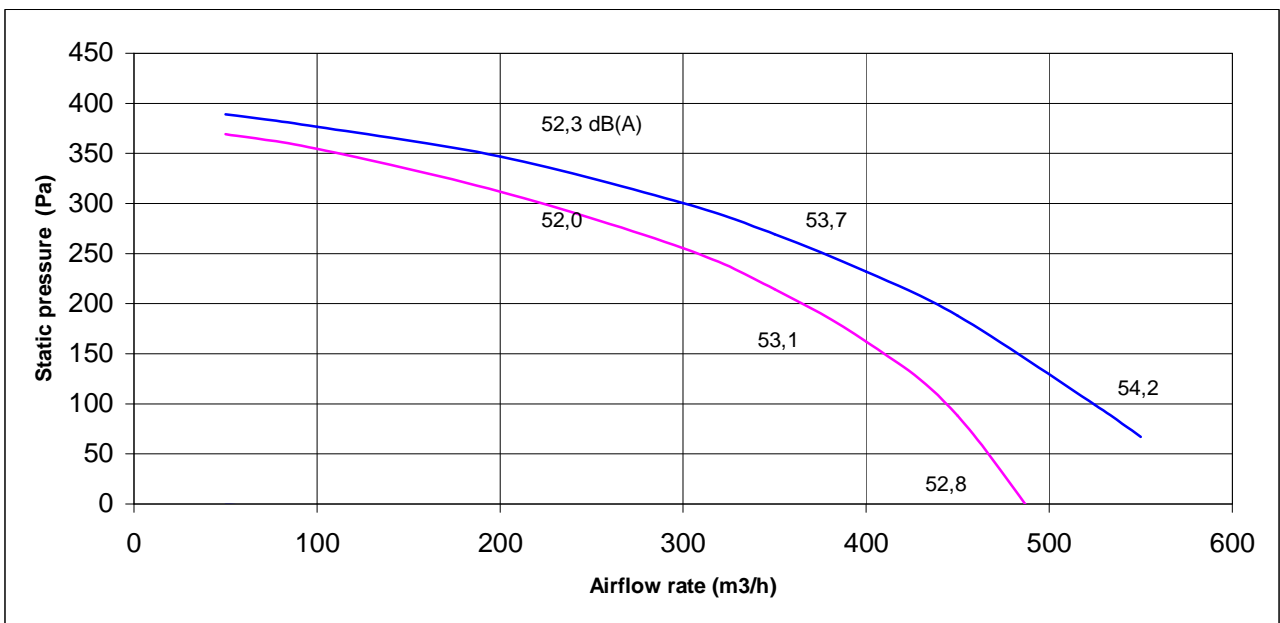



**MINIAIR+ 10**

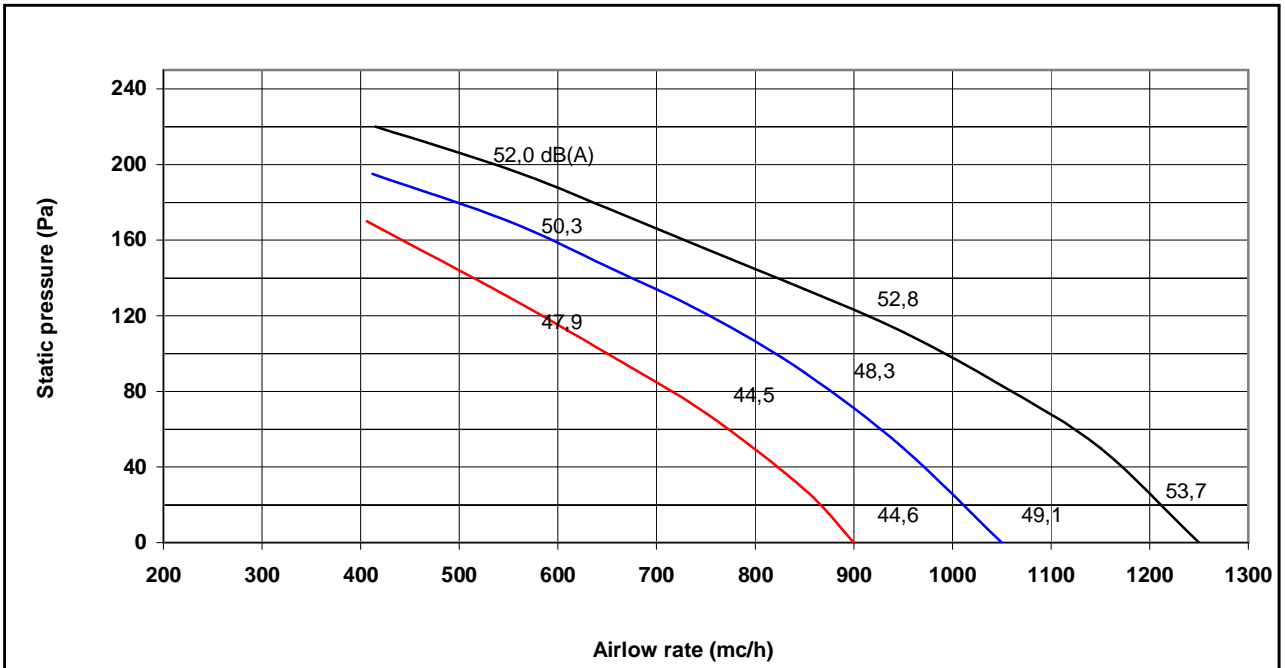

**MINIAIR+ 14**

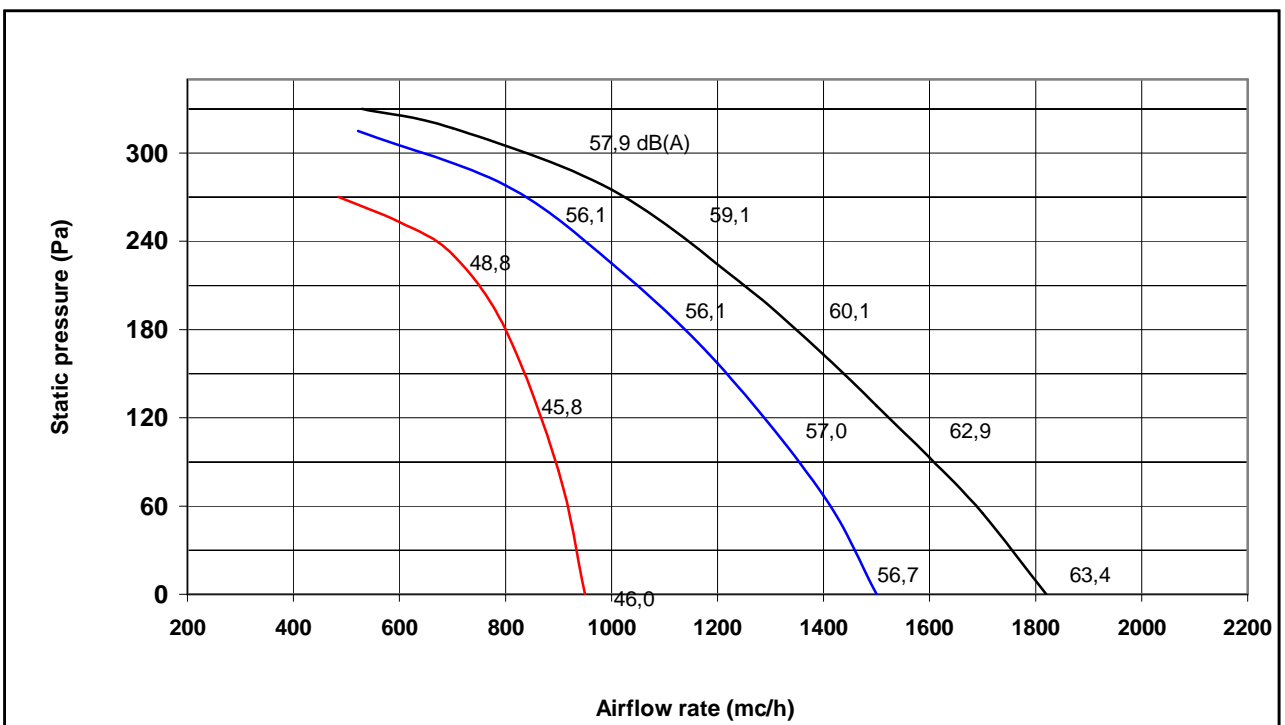

**MINIAIR+ 19**

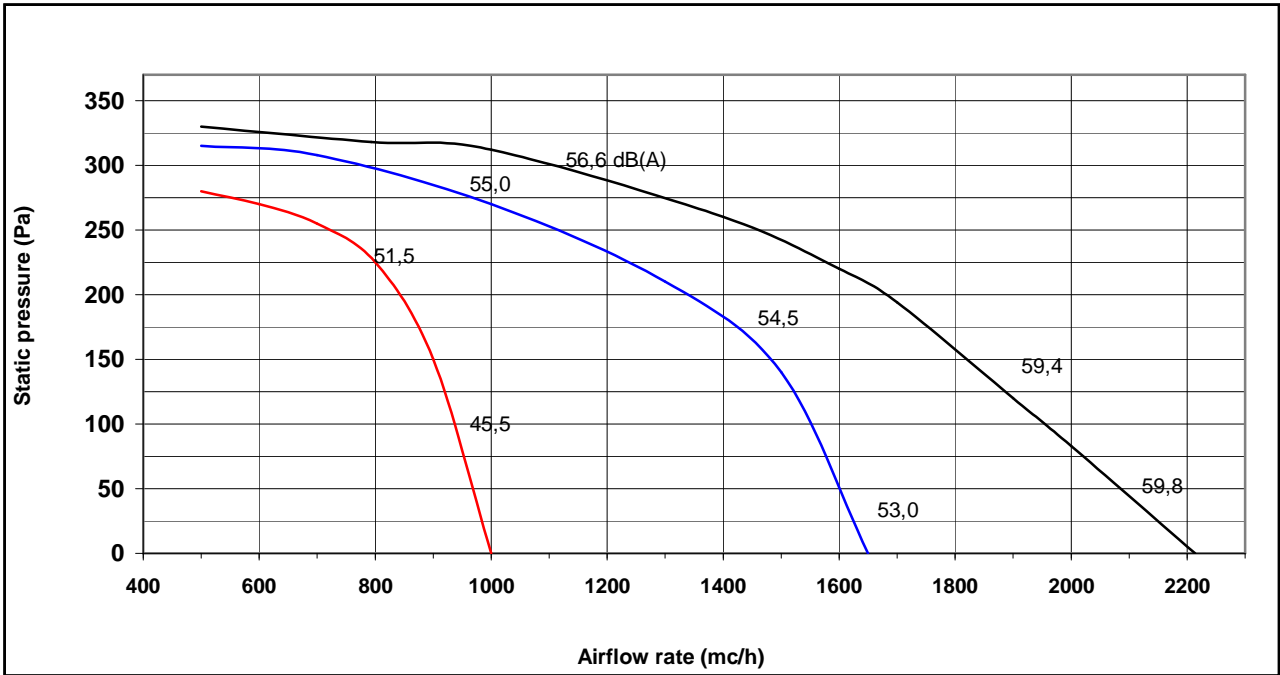

**MINIAIR+ 25**

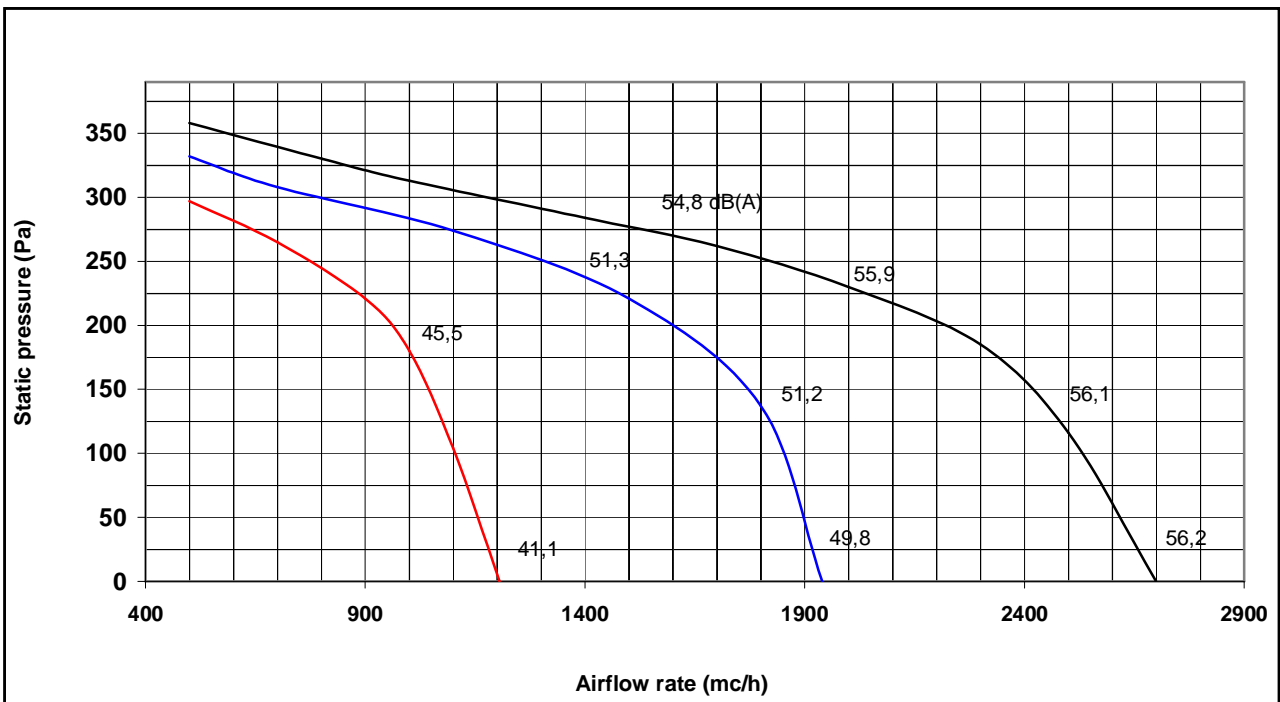

**MINIAIR+ 30**

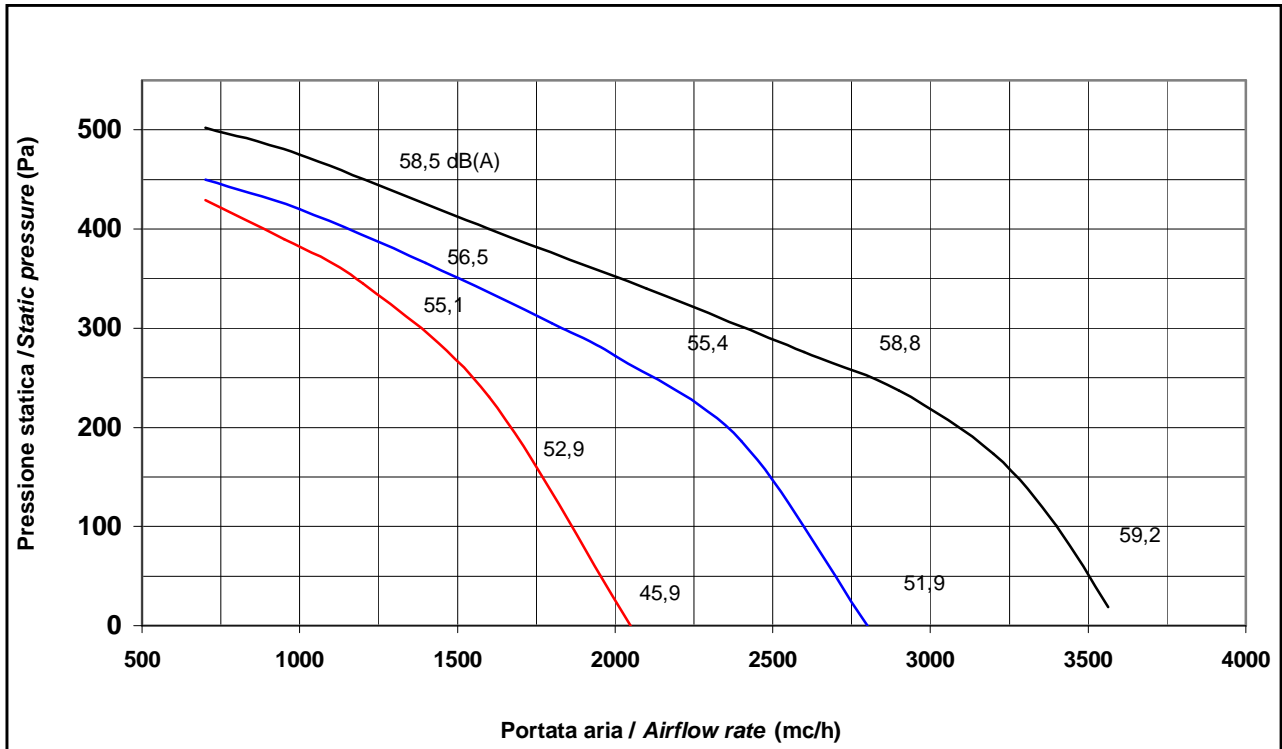

**MINIAIR+ 40**

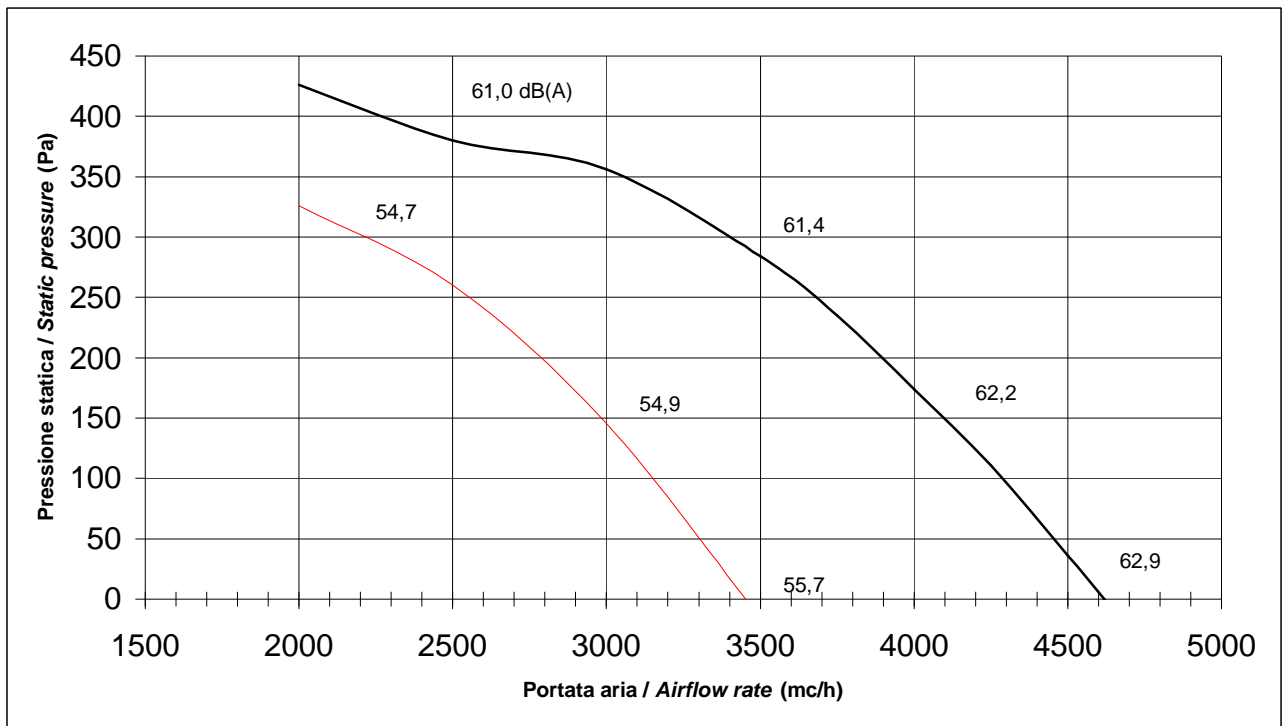

## **SECTION 4 – UNIT IDENTIFICATION**

### **4.1 UNIT IDENTIFICATION**

For a precise definition of the unit it is suggested to specify all necessary data, such as the base model (for example, MINIAIR+/V), then the size (for example, 25), the version (for example, DP), the orientation (for example, type A) and the accessories if present (for example, SKR PSTD); therefore, the complete unit will be defined by:

**MINIAIR+/V 25 DP – type A – SKR PSTD**

Besides, each supplied unit is characterized from its own code and serial number, also present on external CE plate.





[www.lennox europe.com](http://www.lennox europe.com)

**BELGIUM, LUXEMBOURG**  
[www.lennoxbelgium.com](http://www.lennoxbelgium.com)

**CZECH REPUBLIC**  
[www.lennoxczech.com](http://www.lennoxczech.com)

**FRANCE**  
[www.lennoxfrance.com](http://www.lennoxfrance.com)

**GERMANY**  
[www.lennoxdeutschland.com](http://www.lennoxdeutschland.com)

**GREAT BRITAIN**  
[www.lennoxuk.com](http://www.lennoxuk.com)

**NETHERLANDS**  
[www.lennoxnederland.com](http://www.lennoxnederland.com)

**POLAND**  
[www.lennoxpolska.com](http://www.lennoxpolska.com)

**PORTUGAL**  
[www.lennoxportugal.com](http://www.lennoxportugal.com)

**RUSSIA**  
[www.lennoxrussia.com](http://www.lennoxrussia.com)

**SLOVAKIA**  
[www.lennoxdistribution.com](http://www.lennoxdistribution.com)

**SPAIN**  
[www.lennoxspain.com](http://www.lennoxspain.com)

**UKRAINE**  
[www.lennoxrussia.com](http://www.lennoxrussia.com)

**OTHER COUNTRIES**  
[www.lennoxdistribution.com](http://www.lennoxdistribution.com)

Due to Lennox's ongoing commitment to quality, the Specifications, Ratings and Dimensions are subject to change without notice and without incurring liability.

Improper installation, adjustment, alteration, service or maintenance can cause property damage or personal injury.

Installation and service must be performed by a qualified installer and servicing agency.



**MINIAIR-AGU-0507-E**