

EXTRACTION

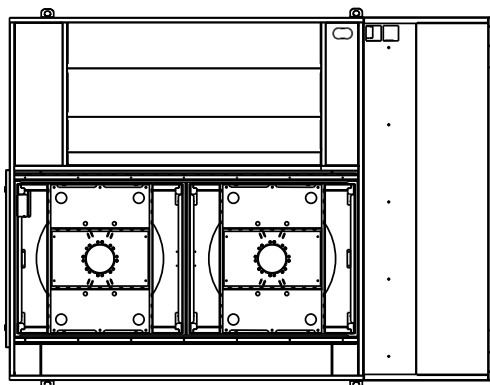

SOUFFLAGE  
SUPPLY AIR

EXTRACTION

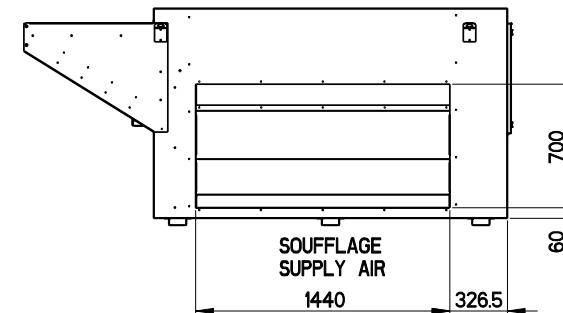
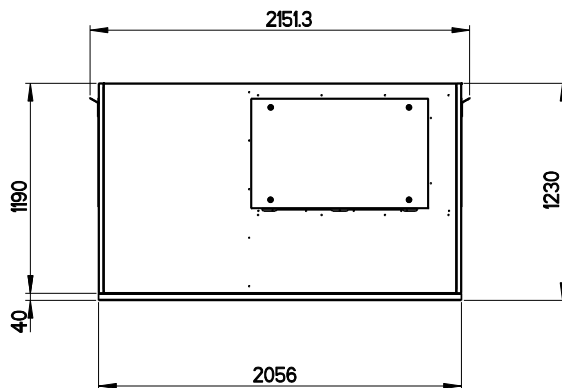
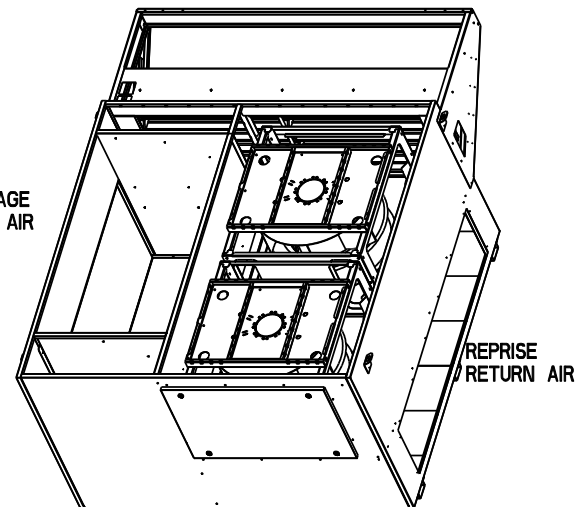

FLEXY-2 F-BOX

RETURN ROOFCURB HORIZONTALFLOW



"LGL Europe" ZI Les Meurières BP 71 69780 Mions France  
Tel : +33 472232020 www.lennox europe.com

TOLERANCE PLAQUE 1/1000 DU FORMAT BENDING TOLERANCE 1/1000 FORMAT	AJOUT SERMAFLEX	SQ	23/02/2009	13FF60001								Weight : 505.58 Kg	folio : 1 / 5	ACF60001 G
TOLERANCE DEBIT TUBE 1/100 DU DEBIT DIMENSIONS TOLERANCE 1/100 OVER ALL DIMENSION	Modification	Name	Date	Code_ERP	Material	Thickness	Painting	Painting color	Diameter	Tube_cut	Date : 03-Oct-08	Designer : SQ		

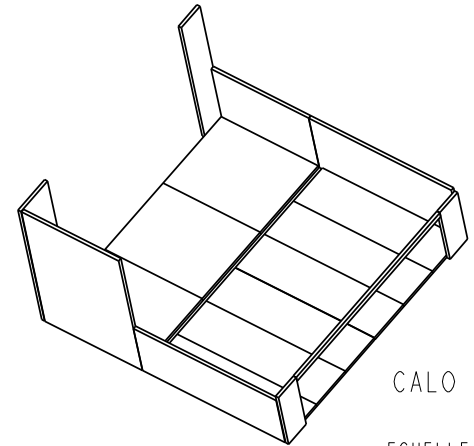
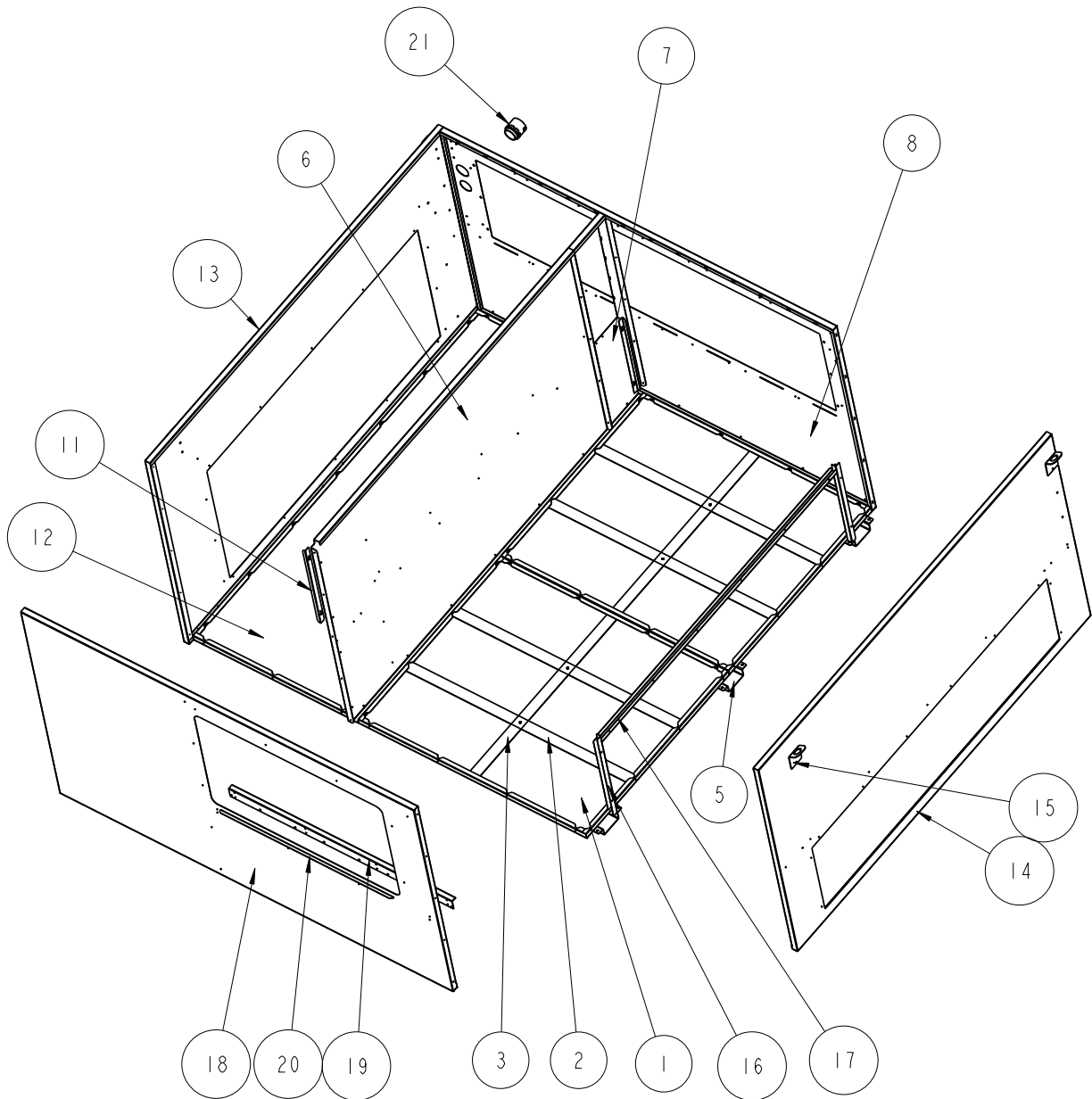

CALO SEF80044  
ECHELLE 0.030

REP	Nb	DESIGNATION
21	1	RACC-SEMAFLEX-PG48-D54
20	1	7500856
19	1	7500846
18	1	7501567
17	1	7501063
16	2	7501064
15	4	7500197
14	1	7501566
13	1	7501568
12	1	7501053
11	2	7500837
8	1	7501825
7	1	7501711
6	1	7501710
5	3	7500853
3	2	7580764
2	4	7580744
1	2	7501052
REP	Nb	DESIGNATION

**FLEXY-2 F-BOX**

**RETURN ROOFCURB HORIZONTALFLOW**

**LENNOX** "LGL Europe" ZI Les Meurières BP 71 69780 Mions France  
Tel : +33 472232020 www.lennox europe.com

Weight : 505.58 Kg folio : 2 / 5  
Date : 03-Oct-08 Designer : SQ

**ACF60001** G

TOLERANCE PLIAGE 1/1000 DU FORMAT BENDING TOLERANCE 1/1000 FORMAT	AJOUT SERMAFLEX	SQ	23/02/2009	13FF60001														
TOLERANCE DEBIT TUBE 1/100 DU DEBIT DIMENSIONS TOLERANCE 1/100 OVER ALL DIMENSION	Modification	Name	Date	Code_ERP	Material	Thickness	Painting	Painting color	Diameter	Tube_cut								

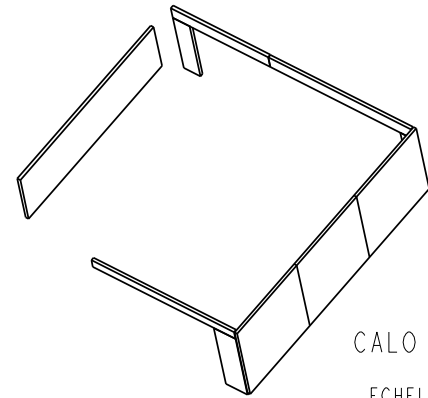
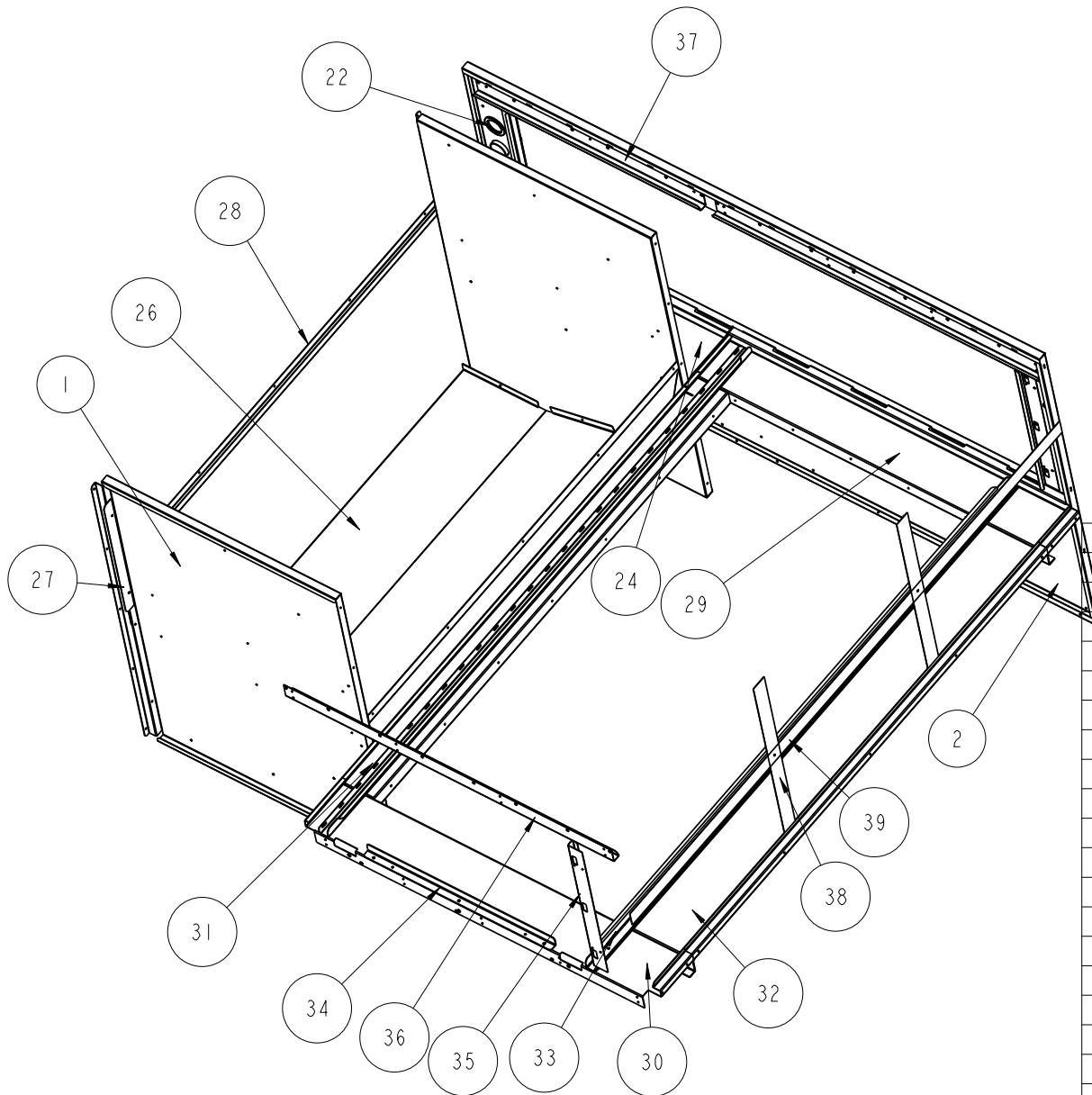

CALO SEF80044  
ECHELLE 0.030

39	1	7580739
38	2	7580709
37	1	7500847
36	2	7500846
35	3	7500845
34	1	7500855
33	2	7501021
32	1	7501019
31	1	7501018
30	1	7501017
29	1	7501016
28	1	7501062
27	1	7580742
26	1	7501057
24	1	7501020
22	1	DG-48-61
3	1	RACC-SEMAFLEX-PG48-D54
2	1	7501825
1	2	7501712
REP	Nb	DESIGNATION

**FLEXY-2 F-BOX**

**RETURN ROOFCURB HORIZONTALFLOW**



"LGL Europe" ZI Les Meurières BP 71 69780 Mions France  
Tel : +33 472232020 www.lennox europe.com

TOLERANCE PLIAGE 1/1000 DU FORMAT BENDING TOLERANCE 1/1000 FORMAT	AJOUT SERMAFLEX	SQ	23/02/2009	13FF60001									Weight : 505.58 Kg	folio : 3 / 5	ACF60001 G
TOLERANCE DEBIT TUBE 1/100 DU DEBIT DIMENSIONS TOLERANCE 1/100 OVER ALL DIMENSION	Modification	Name	Date	Code_ERP	Material	Thickness	Painting	Painting color	Diameter	Tube_cut			Date : 03-Oct-08	Designer : SQ	

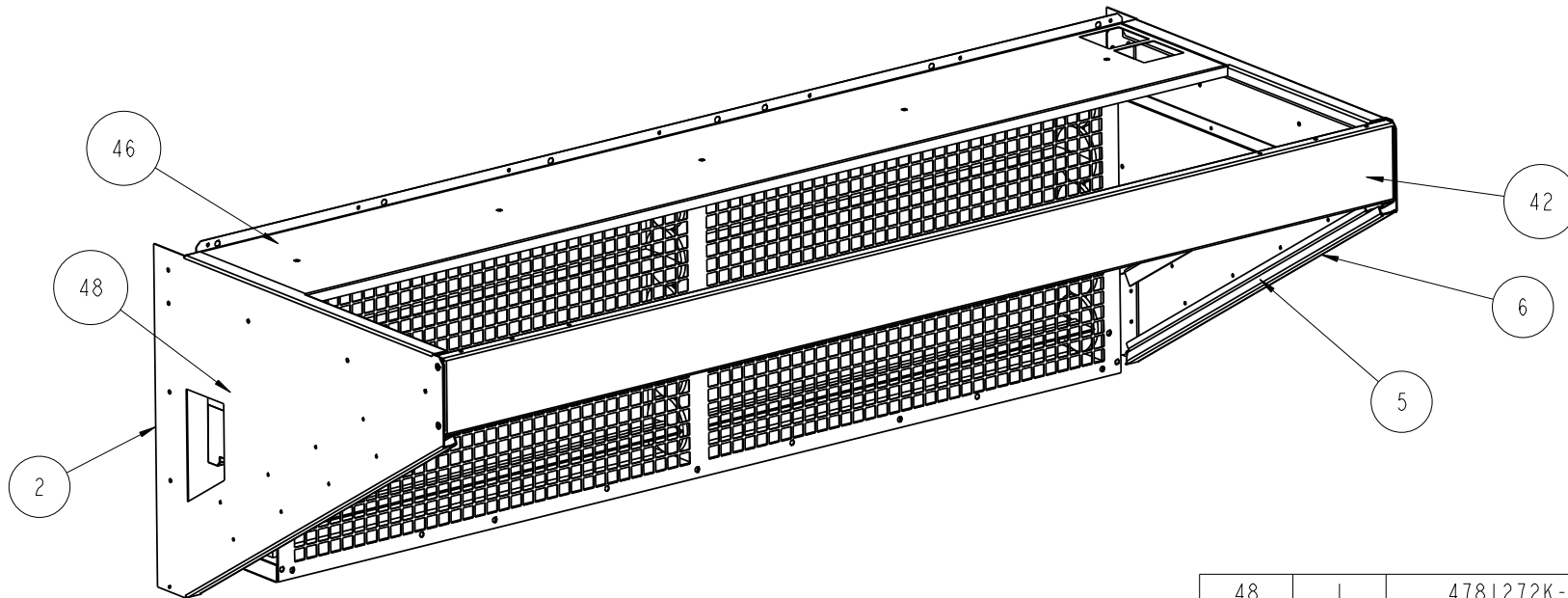

48	1	4781272K-SERVOMOTEUR-24V-SMI7
46	1	SEG61004
42	1	7500832
9	1	7501563
8	1	7501562
7	1	7501561
6	1	7501399
5	1	7501378
4	1	7501377
3	2	7501359
2	1	7501358
1	1	7501353
REP	Nb	DESIGNATION

**FLEXY-2 F-BOX**

**RETURN ROOFCURB HORIZONTALFLOW**



"LGL Europe" ZI Les Meurières BP 71 69780 Mions France  
Tel : +33 472232020 www.lennox europe.com

TOLERANCE PLAQUE 1/1000 DU FORMAT  
BENDING TOLERANCE 1/1000 FORMAT  
TOLERANCE DEBIT TUBE 1/100 DU DEBIT  
DIMENSIONS TOLERANCE 1/100 OVER ALL DIMENSION

AJOUT SERMAFLEX	SQ	23/02/2009	13FF60001								
Modification	Name	Date	Code_ERP	Material	Thickness	Painting	Painting color	Diameter	Tube_cut		

	Weight : 505.58 Kg	folio : 4 / 5
	Date : 03-Oct-08	Designer : SQ

ACF60001 G

