

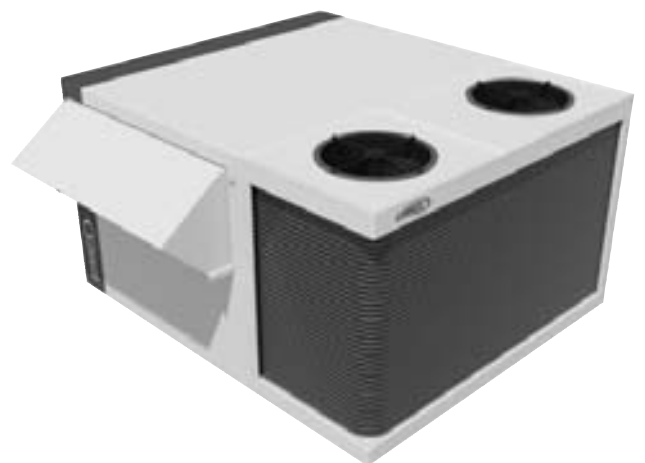

Installation, operating and maintenance **BALTIC R410A**



- Providing indoor climate comfort



INSTALLATION – OPERATING – MAINTENANCE MANUAL

Ref. BALTIC-IOM-0708-E

The present manual applies to the following ROOFTOP versions:

BAC020SNM	BAH020SNM	BAG020SHM	BAG045SSM	BAM020SHM	BAM045SSM
BAC030SNM	BAH030SNM	BAG020SSM	BAG055SHM	BAM020SSM	BAM055SHM
BAC035SNM	BAH035SNM	BAG030SHM	BAG055SSM	BAM030SHM	BAM055SSM
BAC045SNM	BAH045SNM	BAG030SSM	BAG065DHM	BAM030SSM	BAM065DHM
BAC055SNM	BAH055SNM	BAG035SHM	BAG065DSM	BAM035SHM	BAM065DSM
BAC065DNM	BAH065DNM	BAG035SSM	BAG075DHM	BAM035SSM	BAM075DHM
BAC075DNM	BAH075DNM	BAG045SHM	BAG075DSM	BAM045SHM	BAM075DSM

NOTES FOR UNIT FITTED WITH GAS BURNER:

THE UNIT MUST BE INSTALLED IN ACCORDANCE WITH LOCAL SAFETY CODES AND REGULATIONS AND CAN ONLY BE USED IN WELL VENTILLATED AREA.
PLEASE READ CAREFULLY THE MANUFACTURER’S INSTRUCTIONS BEFORE STARTING THIS UNIT.

THIS MANUAL IS ONLY VALID FOR UNITS DISPLAYING THE FOLLOWING CODES: GB IR GR DA NO FI IS

In case these symbols are not displayed on the unit, please refer to the technical documentation which will eventually detail any modifications required to the installation of the unit in a particular country.

LENNOX have been providing environmental solutions since 1895, our range of Baltic™ rooftop continues to meet the standards that have made LENNOX a household name. Flexible design solutions to meet YOUR needs and uncompromising attention to detail. Engineered to last, simple to maintain and Quality that comes as standard. Information on local contacts at www.lennox europe.com.
All the technical and technological information contained in this manual, including any drawing and technical descriptions provided by us, remain the property of Lennox and must not be utilised (except in operation of this product), reproduced, issued to or made available to third parties without the prior written agreement of Lennox.

The technical information and specifications contained in this manual are for reference only. The manufacturer reserves the right to modify these without warning and without obligation to modify equipment already sold.

COMMISSIONING REPORT..... 5

INSTALLATION

Transport - Handling 11
Mandatory handling devices 12
Dimensions and weights 13
Lifting the units 14
Lifting the roofcurbs 15
Lifting the energy recovery module 16
Preliminary checks 17
Minimum clearances around the unit 18
Installation on roof mounting frames 19
 Positioning roofcurb 19
 Non adjustable Non assembled roof curb 20
 Securing the curb 22
 Curbing and flashing 22
 Heat recovery installation 23
Economiser and extraction 24

COMMISSIONING

Electrical connections..... 26
Preliminary checks 26
Starting the unit..... 27
Powering the unit 28

ARRANGEMENT DRAWINGS

BALTIC BAC-BAH-BAG-BAM 020 to 075..... 29
Non adjustable roofcurb 37
Adjustable roofcurb 38
Multidirectional horizontal roofcurb..... 42
Exhaust vertical roofcurb 46
Exhaust horizontal roofcurb 50
Transition roofcurb 53
Energy recovery option..... 54

VENTILATION

Belt tension 58
Mounting & adjusting pulleys 59
Airflow balancing 60
Filters 71
Fan starter 72

HEATING OPTIONS

Hot water coils73
Electric heater75
Gas burners76
Modulating gas burners.....88

CLIMATIC CONTROLLER

See specific content on page 93 93

PRINCIPLE SKETCHES

Refrigerant circuits 114
Hot water coil diagram 117

MAINTENANCE DIAGNOSTIC 118

MAINTENANCE PLAN 121

WARRANTY 124

CERTIFICATES 125

All Baltic Units are compliant with the PED directive 97-23/CE

The following note must be followed carefully

All work on the unit must be carried out by a qualified and authorised employee.

Non-compliance with the following instructions may result in injury or serious accidents.

Work on the unit:

- The unit shall be isolated from the electrical supply by disconnection and locking using the main isolating switch.
- Workers shall wear the appropriate personal protective equipment (helmet, gloves, glasses, etc.).

Work on the electrical system:

- Work on electric components shall be performed with the power off (see below) by employees having valid electrical qualification and authorisation.

Work on the refrigerating circuit(s):

- Monitoring of the pressures, draining and filling of the system under pressure shall be carried out using connections provided for this purpose and suitable equipment.
- To prevent the risk of explosion due to spraying of coolant and oil, the relevant circuit shall be drained and at zero pressure before any disassembly or unbrazing of the refrigerating parts takes place.
- There is a residual risk of pressure build-up by degassing the oil or by heating the exchangers after the circuit has been drained. Zero pressure shall be maintained by venting the drain connection to the atmosphere on the low pressure side.
- The brazing shall be carried out by a qualified brazier. The brazing shall comply with standard NF EN1044 (minimum 30% silver).

Replacing components:

- In order to maintain CE marking compliance, replacement of components shall be carried out using spare parts, or using parts approved by Lennox.
- Only the coolant shown on the manufacturer's nameplate shall be used, to the exclusion of all other products (mix of coolants, hydrocarbons, etc.).

CAUTION:

In the event of fire, refrigerating circuits can cause an explosion and spray coolant gas and oil.

Site details / Informations site		Controller/ Contrôleur
Site / Site	Model/Model	Serial No/ No Série
Unit Ref/ N° Affaire	Refrigerant / Réfrigérant	
Installer/ Installateur		

(1) ROOF INSTALLATION / INSTALLATION SUR LE TOIT

Sufficient Access OK / Accès Suffisants Yes/Oui <input type="checkbox"/> No/ Non <input type="checkbox"/>	Condensate drain fitted / Drainage condensats Installé Yes/Oui <input type="checkbox"/> No/ Non <input type="checkbox"/>	Roofcurb / Costière OK <input type="checkbox"/> Not OK/PasOK <input type="checkbox"/>
--	---	--

(2) CONNECTIONS CHECK / VERIFICATIONS DE RACCORDEMENTS

Phase check/ Vérification des Phases Yes / Oui <input type="checkbox"/> No / Non <input type="checkbox"/>	Voltage between Phases Tension entre Phases	1 / 2	2 / 3	1 / 3
--	--	----------------	----------------	----------------

(3) CLIMATIC CONFIGURATION CHECK / VERIFIER LA CONFIGURATION CLIMATIC

CLIMATIC 50 Configured according to the Options and Specifications / CLIMATIC 50 configuré en fonction des options et des spécifications: Yes/Oui <input type="checkbox"/> No/ Non <input type="checkbox"/>
--

(4) SUPPLY BLOWER SECTION / VENTILATION TRAITEMENT

Type / Type:		N°1	N°2
Power displayed on plate / Puissance affichée sur la plaque:	KW
Voltage displayed on plate / Tension affichée sur la plaque:	V
Current displayed on plate / Intensité affichée sur la plaque:	A
Fan Type / Type de Ventilateur:		Forward / Action <input type="checkbox"/> Backward / Réaction <input type="checkbox"/>	Forward / Action <input type="checkbox"/> Backward / Réaction <input type="checkbox"/>
Displayed Belt Length / Longueur Courroie affichée:	mm
Tension Checked/ Tension Vérifiée:		Yes/Oui <input type="checkbox"/> No/ Non <input type="checkbox"/>	Yes/Oui <input type="checkbox"/> No/ Non <input type="checkbox"/>
Alignment Checked/ Alignement Vérifié:		Yes/Oui <input type="checkbox"/> No/ Non <input type="checkbox"/>	Yes/Oui <input type="checkbox"/> No/ Non <input type="checkbox"/>
Motor Pulley Dia/ Poulie Moteur Dia: D _M	mm
Fan Pulley Dia/ Poulie Ventilateur Dia: D _P	mm
Fan Speed / Vitesse rotation Ventilateur = Motor rpm x D _M / D _P	rpm
Averaged Measured Amps / Intensité Mesurée moyenne:	A
Shaft Mechanical Power (Refer to airflow balancing) Puissance Mécanique à l'Arbre (Voir section réglage débit)	W
Operating point checked / Vérif. Point de fonctionnement:		Yes/Oui <input type="checkbox"/> No/ Non <input type="checkbox"/>	Yes/Oui <input type="checkbox"/> No/ Non <input type="checkbox"/>
Estimated Airflow / Estimation Débit d'Air	m ³ /h

(5) AIRFLOW PRESS. SENSOR CHECK / VERIF. DES SECURITES PRESSOSTATS D'AIR

Measured pressure drop / Pertes de charge au pressostat mbar	Set Points Adjusted / Changement des consignes: Yes/Oui <input type="checkbox"/> No/ Non <input type="checkbox"/> If Yes enter new values/ Si oui noter les nouvelles consignes: 3410: 3411: 3412:
---	--

(6) EXTERNAL SENSOR CHECKS / VERIFICATION DES CAPTEURS EXTERNES

Check electrical connections / Vérification des connections électriques: Yes/Oui <input type="checkbox"/> No/ Non <input type="checkbox"/>	Check and record temp. in menu 2110 / Vérifier et mesurer les températures. Dans menu 2110 : Yes/Oui <input type="checkbox"/> No/ Non <input type="checkbox"/>	
	100% Fresh Air / 100% Air neuf	100% return Air / 100% Air repris
Supply Temperature / Température Soufflage°C°C
Return Temperature / Température reprise°C°C
Outdoor Temperature / Température extérieure°C°C

(7) MIXING AIR DAMPERS CHECKS / VERIFICATIONS VOILETS DE MELANGE

Dampers open & close freely/ Volets s'ouvrent et se ferment OK Yes/Oui <input type="checkbox"/> No/ Non <input type="checkbox"/>	% Minimum FA: %minimum Air Neuf:%	Power exhaust checked/ Ventilateur extraction Yes/Oui <input type="checkbox"/> No/ Non <input type="checkbox"/>	Enthalpy sensor(s) checked/ Control enthalpie installé Yes/Oui <input type="checkbox"/> No/ Non <input type="checkbox"/>
--	---	---	--

(8) REFRIGERATION SECTION / SECTION REFRIGERATION

Outdoor Fan Motor Current / Intensité Moteurs Batterie externe:				Check Rotation		Compressor Voltage/ Tension Compresseur.	
Motor 1 / Moteur 1	L1A	L2A	L3A	Yes/Oui <input type="checkbox"/>	No/ Non <input type="checkbox"/>	Comp1: V	
Motor 2 / Moteur 2	L1A	L2A	L3A	Yes/Oui <input type="checkbox"/>	No/ Non <input type="checkbox"/>	Comp2: V	
Motor 3 / Moteur 3	L1A	L2A	L3A	Yes/Oui <input type="checkbox"/>	No/ Non <input type="checkbox"/>	Comp3: V	
Motor 4 / Moteur 4	L1A	L2A	L3A	Yes/Oui <input type="checkbox"/>	No/ Non <input type="checkbox"/>	Comp4: V	
Motor 5 / Moteur 5	L1A	L2A	L3A	Yes/Oui <input type="checkbox"/>	No/ Non <input type="checkbox"/>		
Motor 6 / Moteur 6	L1A	L2A	L3A	Yes/Oui <input type="checkbox"/>	No/ Non <input type="checkbox"/>		
Compressor Amps COOLING / Intensité Compresseur MODE FROID				Pressures & Temperatures / Pressions & températures			
				Temperatures / Temperatures		Pressures / Pressions	
				Suction/ Asp		Disch / refoul	
				LP/ BP		HP / HP	
Comp 1 A A A °C °C Bar Bar
Comp 2 A A A °C °C Bar Bar
Comp 3 A A A °C °C Bar Bar
Comp 4 A A A °C °C Bar Bar
Check Reversing valves / Vérifier vannes d'inversion:				Valve1/Vanne1: Yes/Oui <input type="checkbox"/> No/ Non <input type="checkbox"/>		Valve3/Vanne3: Yes/Oui <input type="checkbox"/> No/ Non <input type="checkbox"/>	
				Valve2/Vanne2: Yes/Oui <input type="checkbox"/> No/ Non <input type="checkbox"/>		Valve4/Vanne4: Yes/Oui <input type="checkbox"/> No/ Non <input type="checkbox"/>	
Compressor Amps HEATING / Intensité Compresseur en Pompe à Chaleur				Pressures & Temperatures / Pressions & températures			
				Temperatures / Temperatures		Pressures / Pressions	
				Suction/ Asp		Disch / refoul	
				LP/ BP		HP / HP	
Comp 1 A A A °C °C Bar Bar
Comp 2 A A A °C °C Bar Bar
Comp 3 A A A °C °C Bar Bar
Comp 4 A A A °C °C Bar Bar
HP cut out / Coupure HP				LP cut out / Coupure sécurité BP			
Refrigerant charge / Charge réfrigérant				C1 :kg	C2 :kg	C3 :kg	C4 :kg

(8)ELECTRIC HEATER SECTION / SECTION RECHAUFFEUR ELECTRIQUE

Type / Type:	Serial No/ No Série:.....				
AMPS 1 st stage (Baltic) / Intensité 1 ^{er} étage (Baltic)			AMPS 2 nd stage (Baltic) / Intensité 2 ^e étage (Baltic)		
1	2	3	1	2	3

(9) HOT WATER COIL SECTION / SECTION BATTERIE EAU CHAUDE

Check Three Way Valve Movement / Vérification Mouvement Vanne trois voies: Yes/Oui <input type="checkbox"/> No/ Non <input type="checkbox"/>
--

(10) GAS HEATING SECTION / RAMPE GAZ

Gas Burner N°1 / Brûleur gaz N°1				Gas Burner N°2 / Brûleur gaz N°2			
Size / Taille:		Valve type / Type vanne:		Size / Taille:		Valve type / Type vanne:	
Pipe size/ tuyauterie:		Gas type / Type gas : G		Pipe size/ tuyauterie		Gas type / Type gas : G	
Line press./ press. ligne :		Drop test / test pression Yes/Oui <input type="checkbox"/> No/ Non <input type="checkbox"/>		line press./ press. ligne :		Drop test / test pression Yes/Oui <input type="checkbox"/> No/ Non <input type="checkbox"/>	
Check manifold pressure/ Pression injection: High fire/Grande allure.....Low fire/Petite allure.....				Check manifold pressure/ Pression injection: High fire/Grande allure..... Low fire/Petite allure.....			
Pressure cut out airflow press switch / Pression coupure pressostat débit d'air :mbar /Pa				Pressure cut out airflow press switch / Pression coupure pressostat débit d'air :mbar /Pa			
Motor amps I moteur:A	Flue temp / temp fumées °C	CO2 %:%	CO ppm:%	Motor Amps I Moteur:A	Flue temp / temp fumées °C	CO2 %:%	CO ppm:%

(11) REMOTE CONTROL BMS CHECK / VERIFICATIONS BMS CONTROL A DISTANCE

Type / Type:	Sensor type / Type Capteur	Interconnect wiring checked: Yes/Oui <input type="checkbox"/> No/ Non <input type="checkbox"/>
--------------------	----------------------------------	---

It is recommended that you fill the two tables below before transferring the zone settings to the Climatic controller.

Il est recommandé de remplir les deux tableaux ci-dessous avant de transférer les consignes de zones vers le contrôleur Climatic50.

Refer to control section page 55 / Se référer à la section régulation page 55

Time Zones / Zones Horaires

Hour	0	1	2	3	4	5	6	7	8	9	10	11	12	13	14	15	16	17	18	19	20	21	22	23
<i>Example</i>	UNO							7h15	ZA			11h00	ZB			14h00	ZC			19h00	UNO			
Monday																								
Tuesday																								
Wednesday																								
Thursday																								
Friday																								
Saturday																								
Sunday																								

Variables to adjust for each time zone / Consignes à renseigner pour chaque zone horaire

	Start z.A		Start z.B		Start z.C		Start UNO	
	hour (3211)	min (3212)	hour (3213)	min (3214)	hour (3215)	min (3216)	hour (3217)	min (3218)
Monday								
Tuesday								
Wednesday								
Thursday								
Friday								
Saturday								
Sunday								

Description	Unit	Menu	Min	Max	Zone A	Zone B	Zone C	UNOC
Sp Room	°C	3311	8	35				
Mini.Air	%	3312	0	100				
Sp Dyna	°C	3321	0	99.9				
Sp Cool	°C	3322	8	35				
Sp Heat	°C	3323	8	35				
Swap Heater	On/Off	3324	~	~				
Activation	On/Off	3331	~	~				
Swap Heater	On/Off	3332	~	~				
Sp.Dehu	%	3341	0	100				
Sp.Humi	%	3342	0	100				
Fan On/Off	On/Off	3351	~	~				
Fan Dead	On/Off	3352	~	~				
F.Air	On/Off	3353	~	~				
CO2	On/Off	3354	~	~				
Comp.Cool.	On/Off	3355	~	~				
Comp.Heat.	On/Off	3356	~	~				
AuxHeat	On/Off	3357	~	~				
Humidif.	On/Off	3358	~	~				
Low Noise	On/Off	3359	~	~	N/A	N/A	N/A	

COMMENTS:.....

DELIVERY CHECKS

On receipt of a new equipment please check the following points. It is the customer's responsibility to ensure that the products are in good working order:

- The exterior has not been damaged in any way.
- The lifting and handling equipment are suitable for the equipment and comply with the specifications of the handling instructions enclosed here-in.
- Accessories ordered for on site installation have been delivered and are in good working order.
- The equipment supplied corresponds to the order and matches the delivery note.

If the product is damaged, exact details must be confirmed in writing by registered post to the shipping company within 48 hours of delivery (working days). A copy of the letter must be addressed to Lennox and the supplier or distributor for information purposes. Failure to comply will invalidate any claim against the shipping company.

RATING PLATE

The rating plate provides a complete reference for the model and ensures that the unit corresponds to the model ordered. It states the electrical power consumption of the unit on start-up, its rated power and its supply voltage. The supply voltage must not deviate beyond +10/-15 %. The start-up power is the maximum value likely to be achieved for the specified operational voltage. The customer must have a suitable electrical supply. It is therefore important to check whether the supply voltage stated on the unit's rating plate is compatible with that of the mains electrical supply. The rating plate also states the year of manufacture as well as the type of refrigerant used and the required charge for each compressor circuit.

LENNOX		CE 0162		Usine Dijon ZI LONGVIC 21600 LONGVIC FRANCE	
TYPE UNIT TYPE	BAM055NM1M		Usage Climatisation		
IN SERIE	208770 / 1		ANNEE -YAP 2008		
ALIMENTATION	400 V 3 ~ 50 Hz				
I MAX	74.1	I DEPART	223	A	COMMANDE
MAX AMP		START UP AMP		CONTROL DEL	24 V
REFRIGERANT	R410A		kg	13.4	13.4
FLUIDE Group 3			kg		
Date d'essai	18/05/2008		Pression de travail (PT) de l'électrovanne (pression de travail) Maximum working pressure (PT)		
			42.0 bar		
Température stockage	50 °C		Température stockage		
Maximum storage temp			-35 °C		

Fig. 1

STORAGE

When units are delivered on site they are not always required immediately and are sometimes put into storage. In the event of medium to long-term storage, we recommend the following procedures:

- Ensure that there is no water in the hydraulic systems.
- Keep the heat exchanger covers in position (AQUILUX cover).
- Keep protective plastic film in position.
- Ensure the electrical panels are closed.
- Keep all items and options supplied in a dry and clean place for future assembly before using the equipment.

MAINTENANCE KEY

On delivery we recommend that you keep the key which is attached to an eyebolt in a safe and accessible place. This allows you to open the panels for maintenance and installation work.

The locks are ¼ turn + then tighter (figure 2).



Figure 2

CONDENSATE DRAINS

The condensate drains are not assembled when delivered and are stored

in the electrical panel with their clamping collars.

To assemble them, insert them on the condensate tray outlets and use a screwdriver to tighten the collars (Figure 3).



Fig. 3

MANDATORY HANDLING DEVICES

Handling slings to guide the unit towards the roofcurb



Vacuum lifting beam to position the unit



COMPLIANT



NON-COMPLIANT

DIMENSIONS AND WEIGHTS

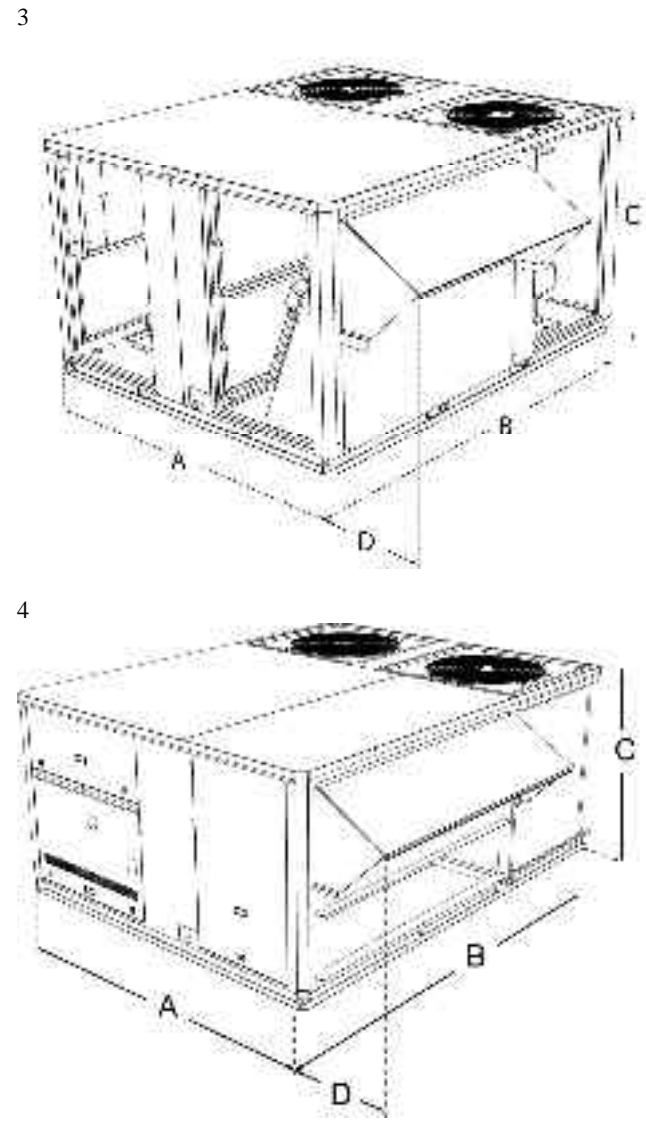
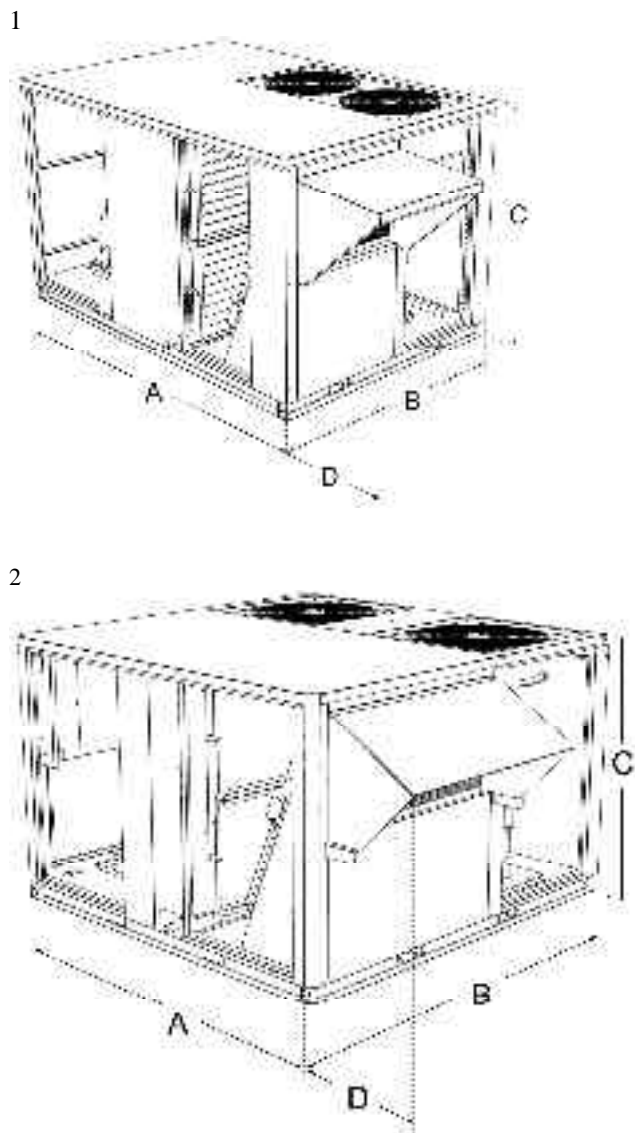

BALTIC™ BAC/BAH/BAG/BAM		20S	30S	35S	45S	55S	65D	75D
A	mm	2017	2017	1890	1910	1910	2260	2260
B	mm	1418	1418	1915	2235	2235	2873	2873
C	mm	1220	1220	1221	1221	1221	1225	1225
D	mm	484	484	414	418	418	418	418
Weight of standard units								
Without hood	kg	394	414	547	604	619	796	852
With hood	kg	417	437	575	677	652	837	893
Poids des unités à gaz								
Standard heat without hood	kg	445	465	608	678	693	904	960
Standard heat with hood	kg	468	488	636	711	726	945	1001
High heat without hood	kg	454	474	627	700	715	963	1019
High heat with hood	kg	477	497	655	733	748	1004	1060

LIFTING THE UNITS

B box

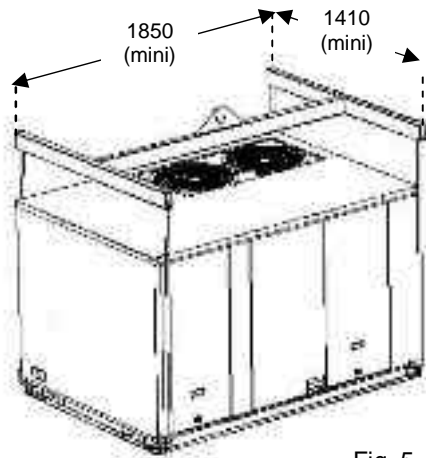

Fig. 5

C box

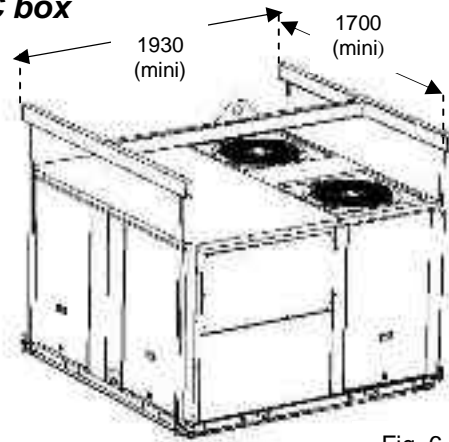

Fig. 6

D box

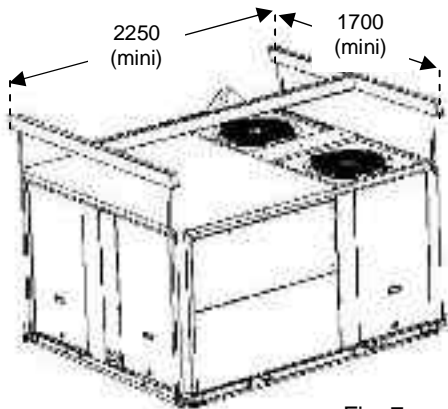

Fig. 7

E box

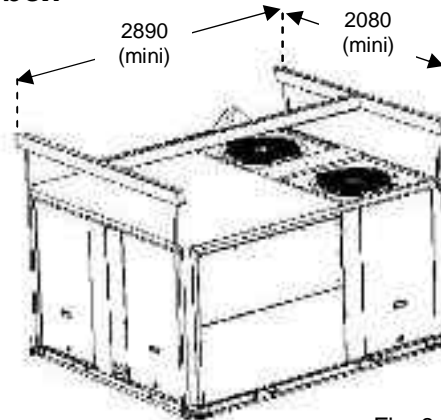

Fig. 8

RETRACTABLE LIFTING LUG



Fig. 9

LIFTING THE ROOF CURBS

ADJUSTABLE ROOF CURB

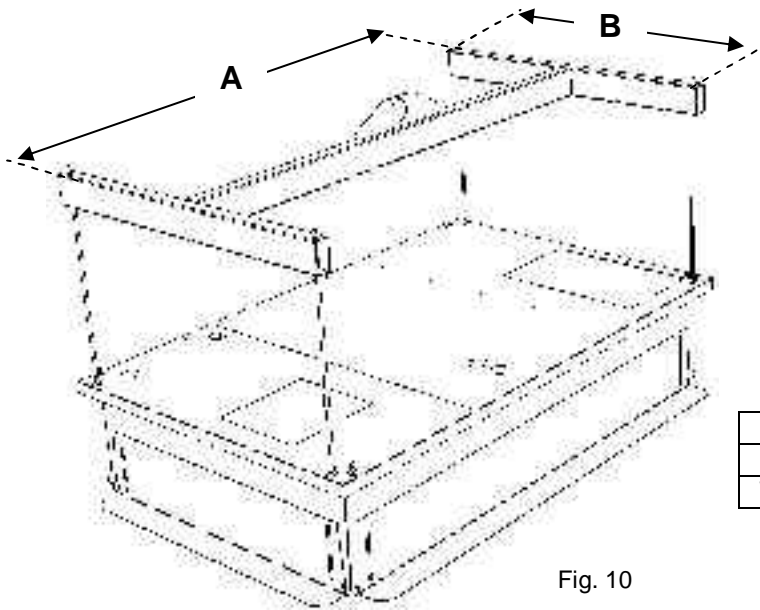

Fig. 10

Dimensions (mm)

	B box	C box	D box	E box
A	1890	1735	1735	2085
B	1100	1295	1545	1995

Weights (kg)

	B box	C box	D box	E box
No aux.heating	87	94	104	152
With aux.heating	86	90	100	138.2

EXHAUST ROOF CURB

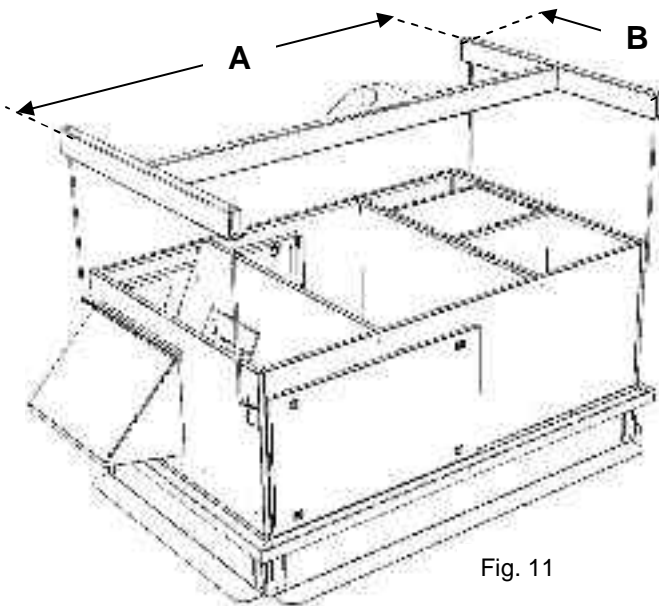

Fig. 11

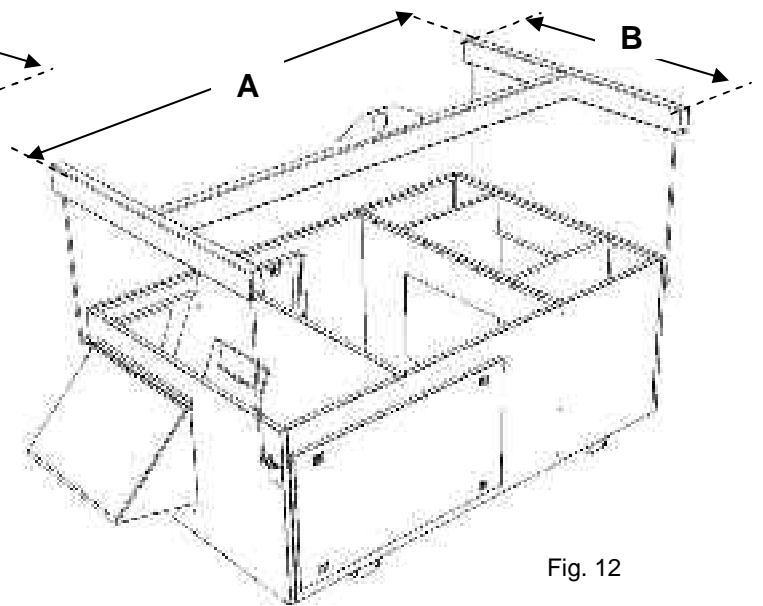

Fig. 12

Dimensions

	B box	C box	D box	E box
A	2050	1900	1900	2250
B	1160	1360	1610	2060

Weights

	B box	C box	D box	E box
Vertical No aux.heating	192	220	240	370
Vertical With aux.heating	194	194	240	365
Horizontal	142	168	185	301

MULTIDIRECTIONAL ROOF CURB

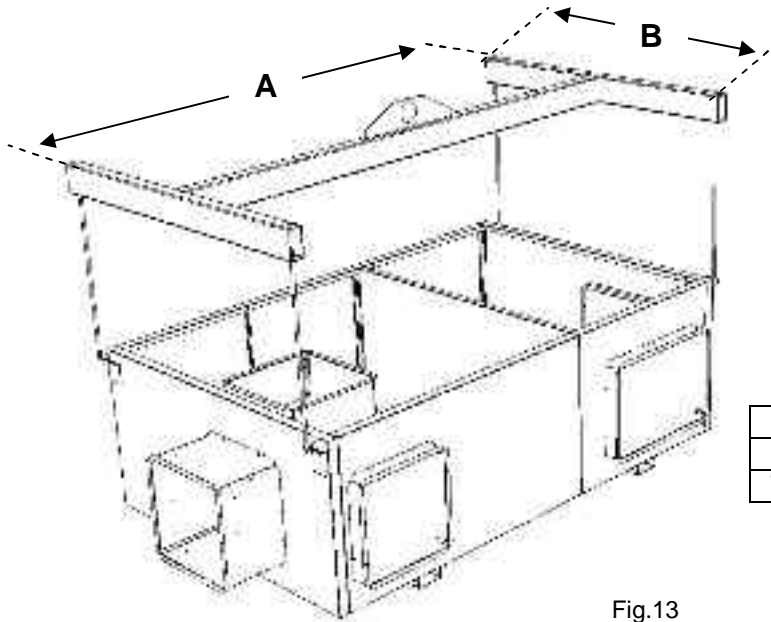

Dimensions (mm)

	B box	C box	D box	E box
A	2050	1900	1900	2250
B	1160	1360	1610	2060

Weights (kg)

	B box	C box	D box	E box
No aux.heating	81	88	100	147
With aux.heating	90	93	103	146.7

Fig.13

LIFTING THE ENERGY RECOVERY MODULE

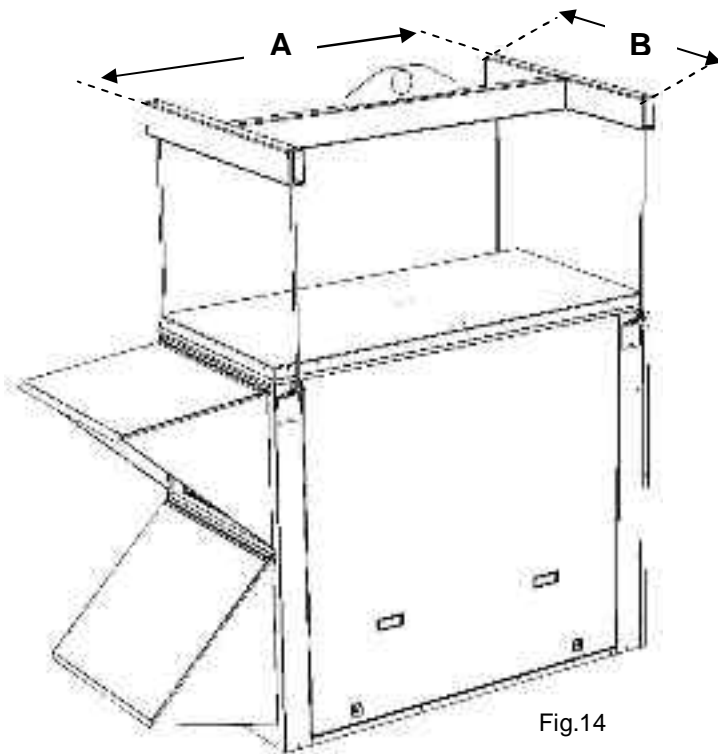

Dimensions

	B box	C box	D box	E box
A	1290	1290	1290	1290
B	820	1170	1547	1895

Weights (kg)

B box	C box	D box	E box
143	172	229	317

Fig.14

FORKLIFT PROTECTIONS**REMOVE THE FORKLIFT PROTECTIONS BEFORE INSTALLATION**

Fig. 15

PRELIMINARY CHECKS

Before installing the equipment, the following points **MUST** be checked:

- Have the forklift protections been removed?
- Is there sufficient space for the equipment?
- Is the surface on which the equipment is to be installed sufficiently solid to withstand its weight? A detailed study of the frame must be made beforehand.
- Do the supply and return ductwork openings excessively weaken the structure?
- Are there any obstructing items which could hinder the operation of the equipment?
- Does the electrical power available correspond to the equipment's electrical specifications?
- Is drainage provided for the condensate?
- Is there sufficient access for maintenance?
- Installation of the equipment could require different lifting methods which may vary with each installation (helicopter or crane). Have these been evaluated?
- Ensure that the unit is installed in accordance with the installation instructions and local applicable codes.
- Check to ensure that the refrigerant lines do not rub against the cabinet or against other refrigerant lines.

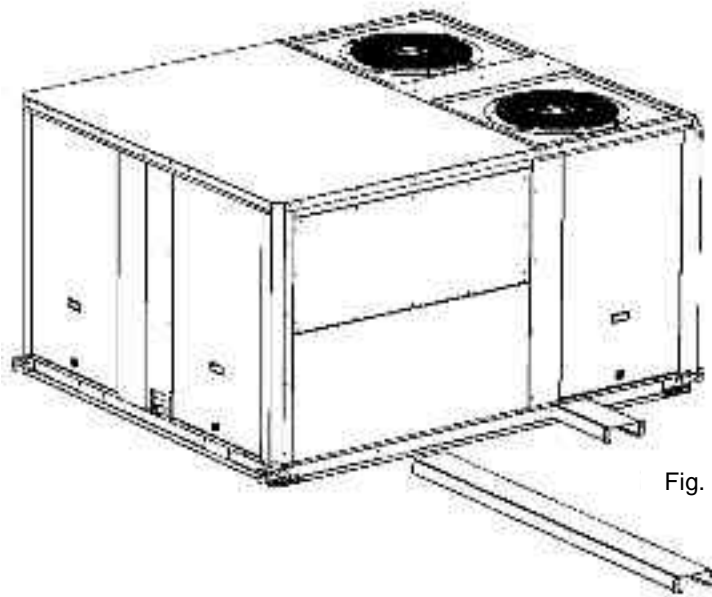
In general, make sure no obstacles (walls, trees or roof ledges) are obstructing the duct connections or hindering assembly and maintenance access.

INSTALLATION REQUIREMENTS

The surface on which the equipment is to be installed must be clean and free of any obstacles which could hinder the flow of air to the condensers:

- Avoid uneven surfaces
- Avoid installing two units side by side or close to each other as this may restrict the airflow to the condensers.

Before installing a packaged Rooftop unit it is important to understand:

- The direction of prevailing winds
- The direction and position of air flows.
- The external dimensions of the unit and the dimensions of the supply and return air connections.
- The arrangement of the doors and the space required to open them to access the various components.

CONNECTIONS

- Ensure that all the pipe-work crossing walls or roofs are secured, sealed and insulated.
- To avoid condensation problems, make sure that all pipes are insulated according to the temperatures of fluids and type of rooms.

NOTE: The AQUILUX protection sheets fitted to the finned surfaces must be removed prior to start up.

MINIMUM CLEARANCE AROUND THE UNIT

Figure 4 shows the required clearances and service access around the unit.

NOTE: Ensure the fresh air inlet does not face prevailing wind direction.

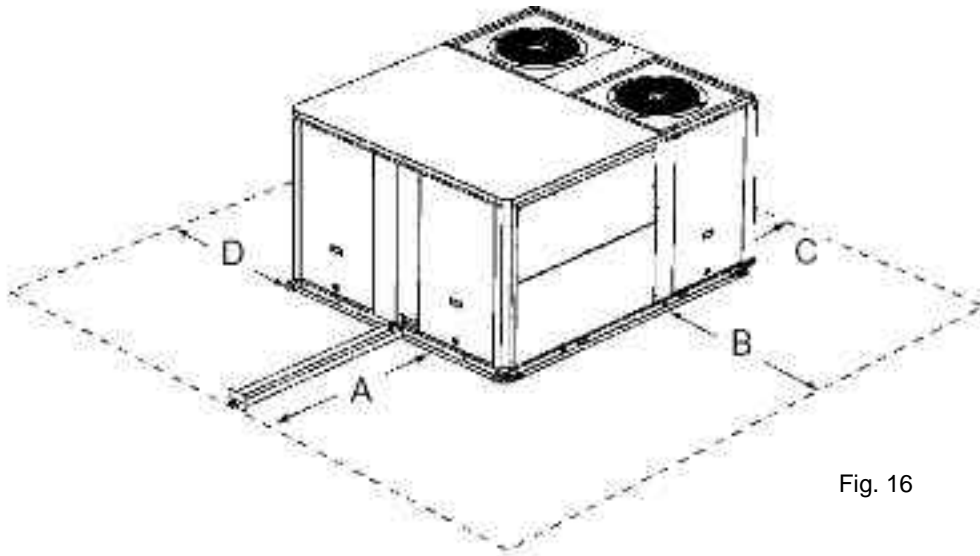

Fig. 16

	A	B	C	D
B Box	1000 ⁽¹⁾	1500 ⁽²⁾	1500	1000
C Box	1200 ⁽¹⁾	1500 ⁽²⁾	1500	1000
D Box	1400 ⁽¹⁾	1500 ⁽²⁾	1500	1000
E Box	1800 ⁽¹⁾	1500 ⁽²⁾	1500	1100

- (1) Add 1 meter if the units are equipped with gas burner
- (2) Double this distance if the units are equipped with extraction

POSITIONING ROOFCURBS

As levels are adjustable, observe the following recommendations when installing the equipment.

Above all, ensure that all the adjustable returns are facing outward ("**1**" **figure 17**). They are usually turned inside-out for transport.

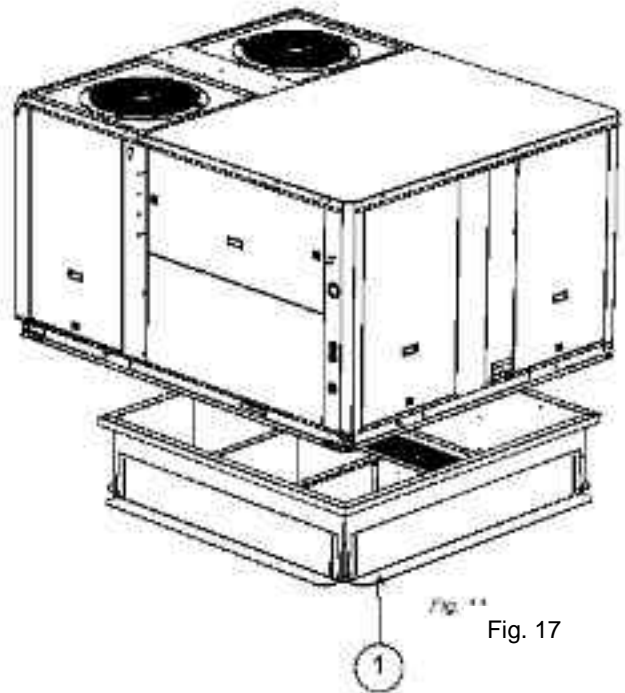

Place the roof mounting frame on the trimmer beam by first lining up the inlet and the outlet opening. ("**2**"- **figure 18**)

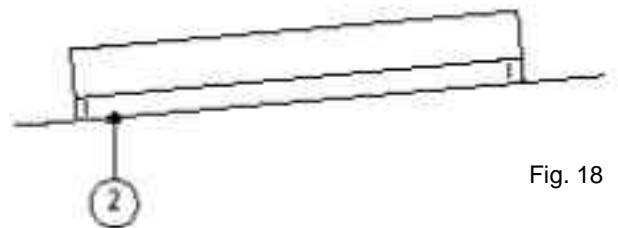

After levelling the frame, secure the adjustable returns on the trimmer.

It is important to centre the unit on the roof frame.

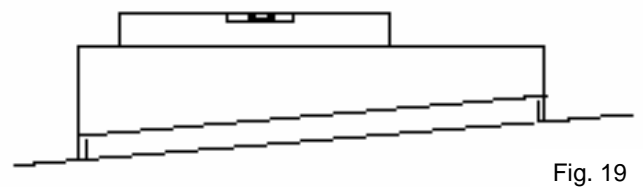

NON ADJUSTABLE NON ASSEMBLED ROOFCURB

FRAME PARTS IDENTIFICATION

Figure 20 shows the different parts used in the assembly of this roof mounting frame.

INSTALLATION

The roof mounting frame provides support when the units are installed in down-flow configurations. The non adjustable, non assembled roof mounting frame can be installed directly on decks having adequate structural strength or on roof supports under deck. See page 24 for frame dimensions, location of supply and return air opening

NOTE: frame assembly must be installed flat, levelled within 5mm per linear meter in any direction.

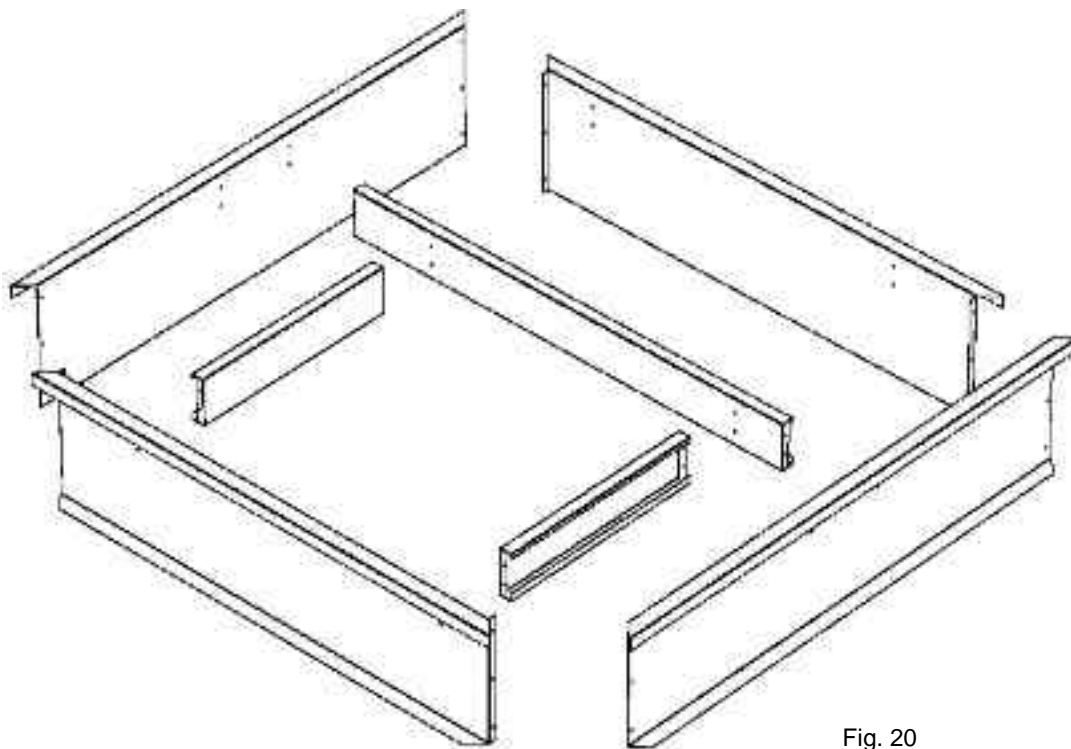

Fig. 20

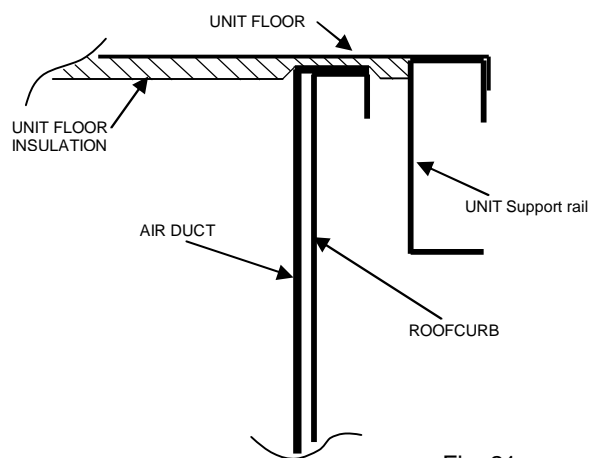

Fig. 21

NON ADJUSTABLE NON ASSEMBLED ROOFCURB

ASSEMBLY

The frame is supplied as a single package and shipped folded down for ease of transport and handling. It is easy field assembled as all parts required are supplied with the frame.

SECURING THE FRAME

To ensure proper mating with units (figure 22), it is mandatory that the roof mounting frame be squared to roof structure as follows:

- With frame positioned levelled in the desired location on roof trusses, tack weld corner of frame.
- Measure frame diagonally from corner to corner as shown in figure 16. These Dimensions must be equal in order for the fame to be square.
- It is extremely important to sight frame from all corner to ensure it is not twisted across. Shim frame under any low side. The maximum slope tolerance is 5mm per linear meter in any direction.
- After the frame has been squared, straightened and shimmed, weld or secure the frame to the roof deck.

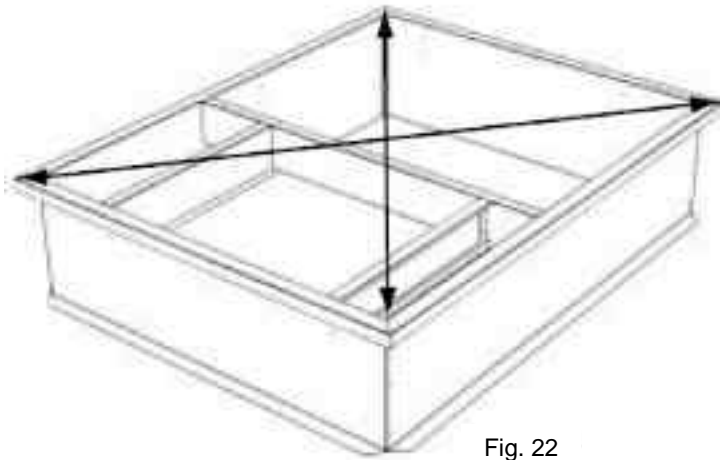

Fig. 22

NOTE: It must be securely fastened to the roof as per local codes and regulations.

SECURING THE CURB

When the frame is correctly positioned, it is essential to secure the assembly with a disconnected stitched welded seam (20 to 30 mm every 200 mm - - -) along the outside or by using an alternative method.

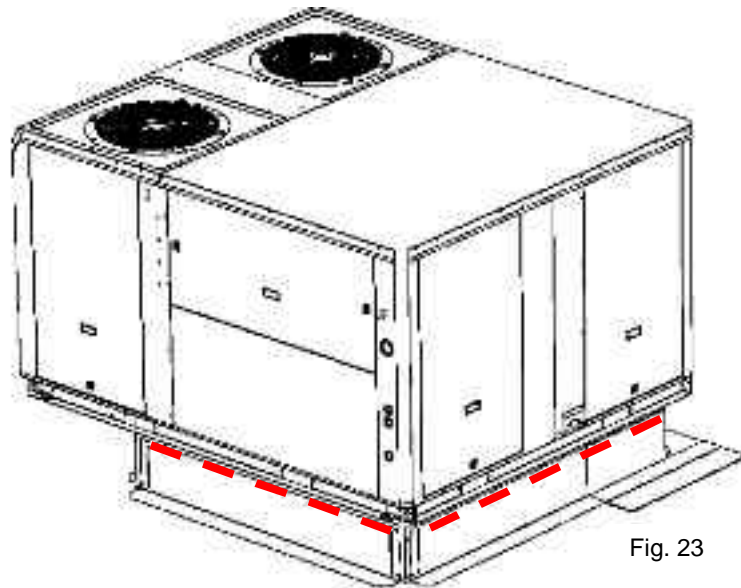

Fig. 23

CURBING AND FLASHING

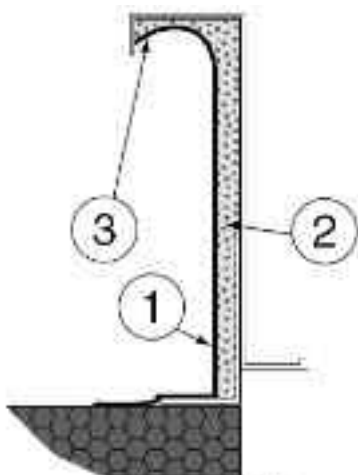

Fig. 24

Outside of frame must be insulated with rigid type insulation;
We recommend a minimum of 20 mm thick insulation (2 figure 24).

Check that the insulation is continuous, counter flash and seal around the frame as shown in (1-figure 24).

CAUTION: To be effective, the upstream must end below the drop edge (3 - figure 24).

Where pipes and electrical conduits extend through the roof, flashing must conform to local codes of practice

Before installing the equipment, make sure that seals are not damaged and check that the unit is secured to the mounting frame. Once in position, the bottom of the equipment must be horizontal.
The installer must comply with local authority standards and specifications.

Heat Recovery Installation

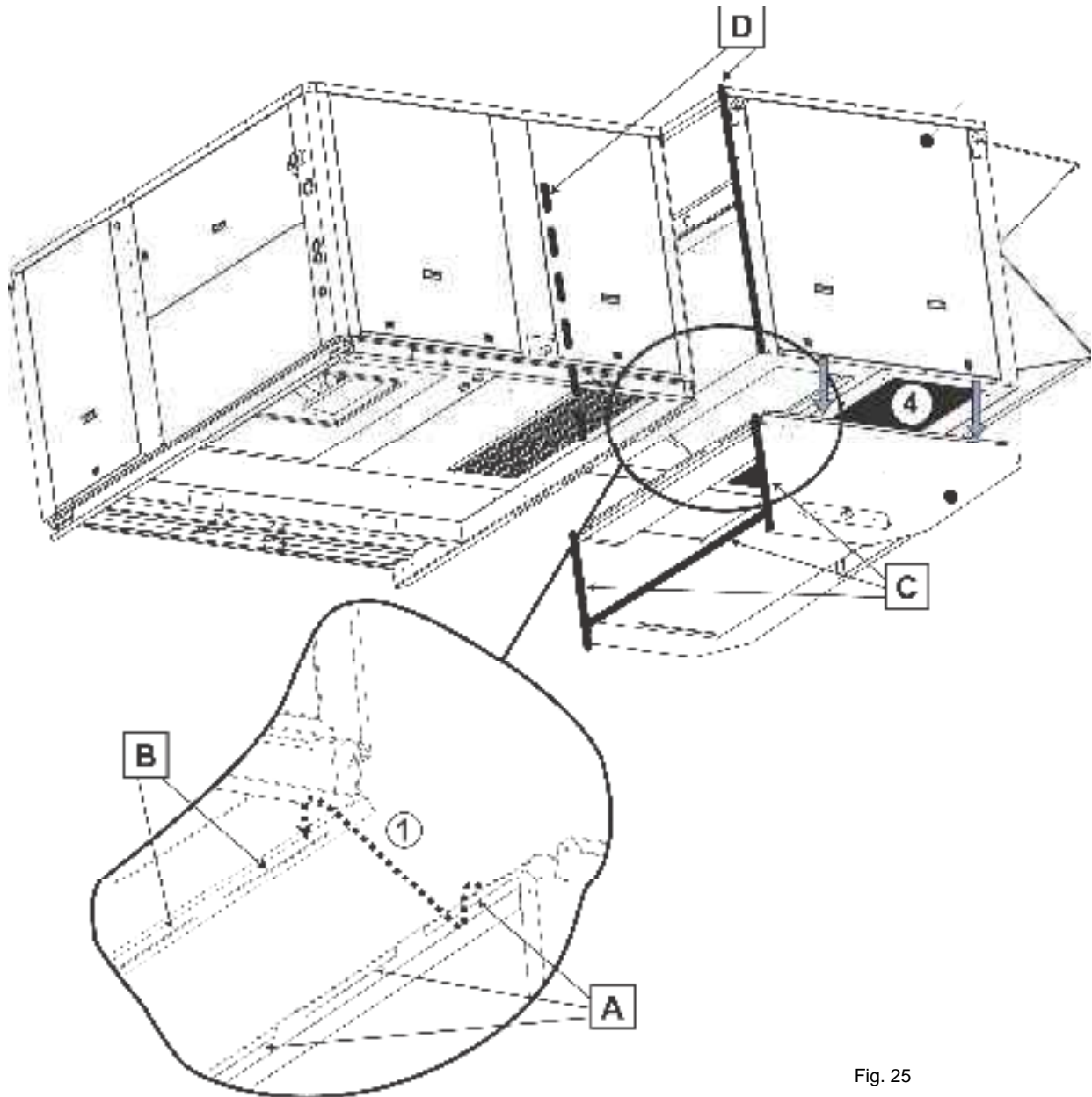

Fig. 25

- 1) The unit being already erected on the roof curb, position the elbow by plugging the returns (A) in the slits (B) of the framework of the unit: see detail **1**
- 2) Fix the elbow with caged nuts at envisaged places (C)
- 3) Apply mastic on the two side studs and on the superior stud of the energy recovery box.
- 4) Pose the energy recovery box on the elbow **4**
- 5) Fix the energy recovery box thanks to the two edges at 45° right and left with self-drilling screws (D)

Economiser

Free cooling can be provided through the use of fresh air where appropriate rather than cooling excessive amounts of return air.

The economiser is factory fitted and tested prior to shipment. It includes two dampers operating from a 24V actuator

Rain hood

It also includes a factory fitted rain hood. Hoods is folded during transportation to limit risks of damage and must be unfolded on site as shown on fig. 26

Extraction

Installed with economiser assembly, the gravity exhaust dampers relieve the pressure when outside air is introduced into the system.

When large amount of fresh air is introduced into the system power exhaust fans can be used to equalise the pressures.

The extraction fan runs when return air dampers are being closed and supply air blower is in operation. The extraction fan runs when outdoor air dampers are at least 50% open (adjustable value). It is overload protected.

NOTE: When horizontal flow configuration is required, the multidirectional roof curb will be installed.

0-25% fresh air manual (Fig. 27)

It is enough to loosen the mobile grid's screws and to make it slip.

0%: screw into limit stop on the right

25%: screw into limit stop on the left

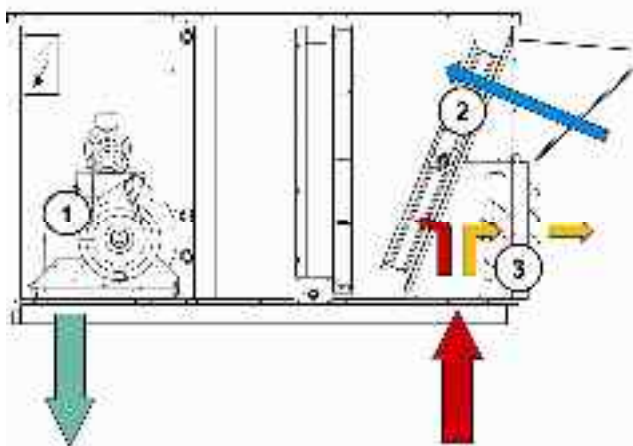

Fig. 26

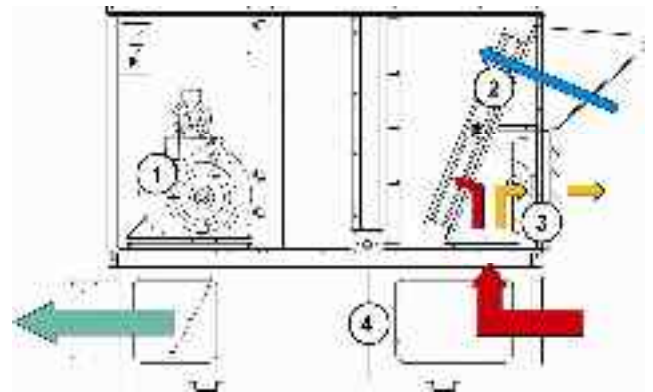

Fig. 27

VERTICAL FLOW



MULTIDIRECTIONAL ROOFCURB



**ENERGY RECOVERY MODULE + EXHAUST ROOFCURB
(Vertical flow)**

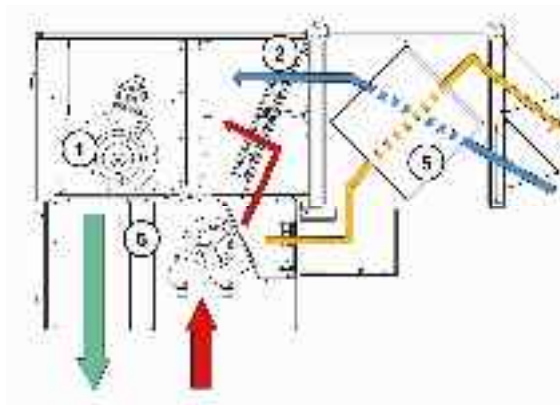

**ENERGY RECOVERY MODULE + EXHAUST ROOFCURB
(Horizontal flow)**

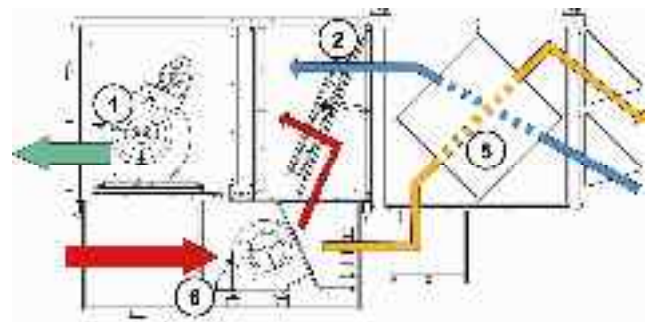

	Fresh air	1	Supply fan	4	Multidirectional roofcurb
	Return air	2	Economiser damper	5	Heat recovery module
	Exhaust air	3	Exhaust damper	6	Exhaust Roofcurb
	Supply air				

THIS WORK MUST ONLY BE CARRIED OUT BY TRAINED REFRIGERATION ENGINEERS

FILL THE COMMISSIONING SHEET AS YOU GO ALONG

ELECTRICAL CONNECTIONS

- Ensure that the power supply between the building and the unit meets local authority standards and that the cable specification satisfies the start-up and operating conditions.

ENSURE THAT THE POWER SUPPLY INCLUDES 3 PHASES (+ NEUTRAL if the unit is equipped with the power exhaust fan)

- Check the following wire connections for tightness: Main switch connections, mains wires linked to the contactors and circuit breakers and the cables in the 24V control supply circuit.

How to connect roof curbs and energy recovery module

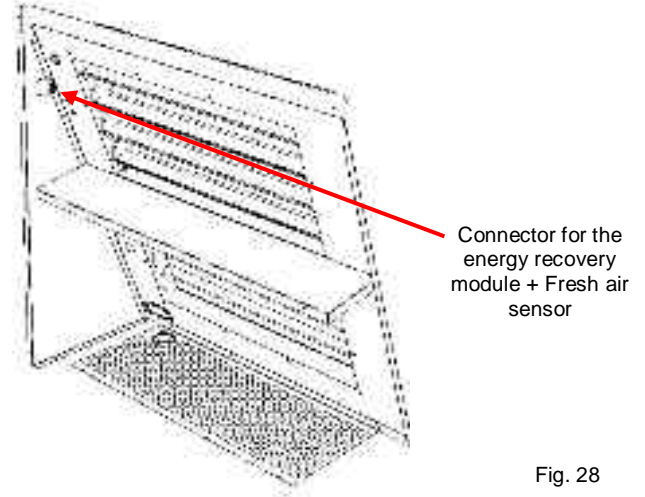
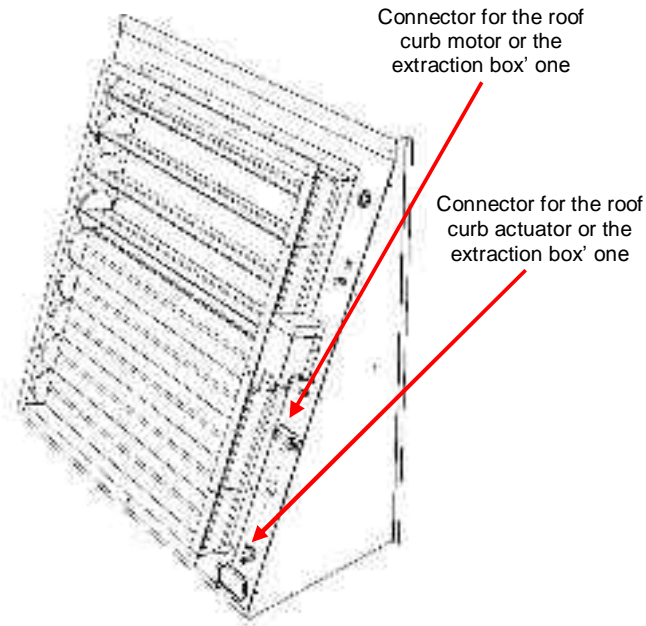

Fig. 28

Cables and their connectors corresponding to the roof curb' motor and actuator and extraction box' ones are already rolled up in these elements; it is enough to bring them through the openings envisaged and to connect them on the sites indicated on the figure 28.

It's the same procedure when you have an energy recovery module.

PRELIMINARY CHECKS

- Ensure that all drive motors are secure.
- Ensure that the adjustable pulley blocks are secure and that the belt is tensioned with the transmission correctly aligned. Refer to the next section for details.
- Using the electrical wiring diagram, check the conformity of the electrical safety devices (circuit breaker settings, presence and rating of fuses).
- Check the temperature probe connections.



Fig.29

STARTING THE UNIT

At this point the unit circuit breakers should be open

You will need a **DS50** maintenance controller or Climalook with appropriate Interface.

Fig. 30



The jumpers are factory set and the configuration switches are adjusted depending on the option the type of unit.

Connecting the CLIMATIC displays



Fig. 31

Close the 24V Control Circuit breakers.

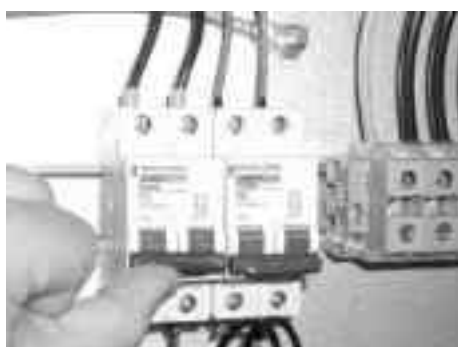

Fig. 32

The CLIMATIC 50 starts after 30s

Reset the DAD photo (If fitted)

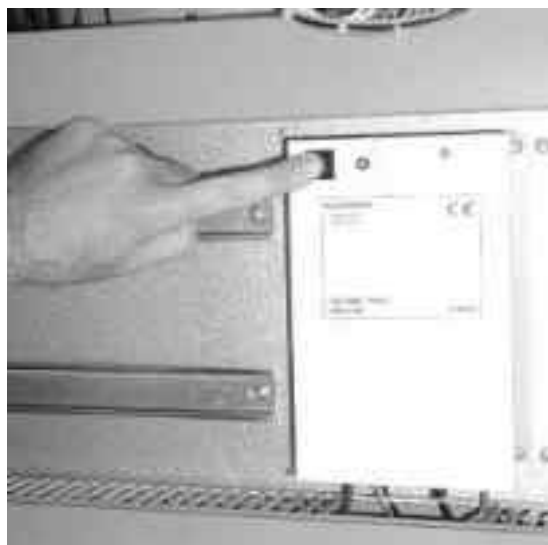

Fig. 33

Check and adjust the control settings.

Refer to the control section in this manual to adjust the different parameters

POWERING THE UNIT

- Power up the unit by closing the isolator switch (if fitted).
- At this point the blower should start unless the climatic does not energise the contactor. In this particular case the blower can be forced by bridging the port NO7 and C7 on connector J14 on the Climatic. Once the fan is running, check the rotation direction. Refer to the rotation arrow located on the fan.
- The fans and compressors direction of rotation is checked during the end of line test. They should therefore all turn in either the right or wrong direction.

NOTE: A compressor rotating in the wrong direction will fail.

- If the fan turns in the wrong direction (the right direction is shown on figure n° 27), disconnect the main power supply to the machine at the building's mains switch, reverse two phases and repeat the above procedure.
- Close all circuit breakers and power up the unit, remove the bridge on connector J14 if fitted.
- If now only one of the components rotates in the wrong direction, disconnect the power supply at the machine's isolator switch (if fitted) and reverse two of the component's phases on the terminal within the electrical panel.
- Check the current drawn against the rated values, in particular on the supply fan (ref. page 34).
- If the readings on the fan are outside the specified limits, this usually indicates excessive air flow which will affect the life expectancy and the thermodynamic performances of the unit. This will also increase the risks of water ingress into the unit. Refer to the "Air Flow Balancing" section to correct the problem.

At this point attach the manometers to the refrigerant circuit

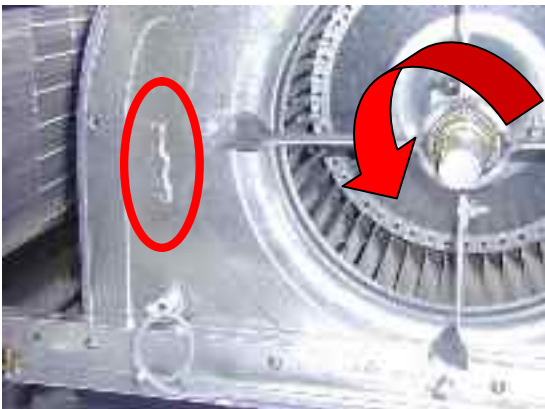

Fig. 34

RUN TEST

Start unit in cooling mode

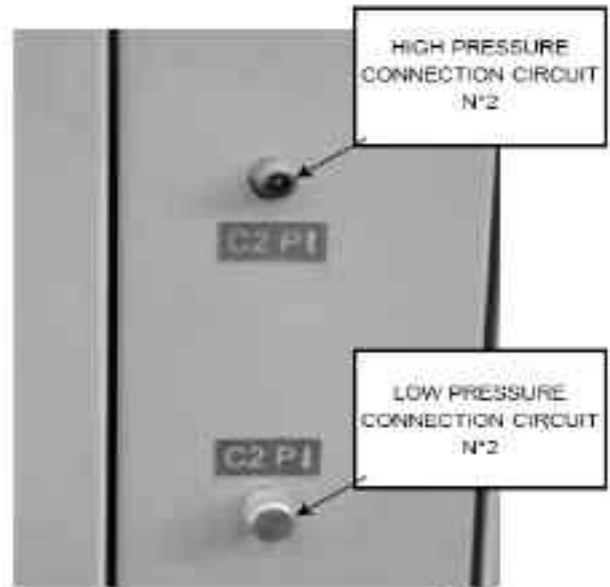

Fig. 35

Thermodynamic readings using manometers and prevailing environmental conditions

No rated values are given here. These depend on the climatic conditions both outside and inside the building during operation. However, an experienced refrigeration engineer will be able to detect any abnormal machine operation.

Safety test

- Check Air pressure switch (if fitted) "Dirty filter" detection test: vary the set-point value (**menu page 3413 on DS50**) in respect to the air pressure value. Observe the response of the CLIMATIC™.
- Same procedure for detecting "Missing Filter" (**page menu 3412**) or "Air Flow Detection" (**page menu 3411**).
- Check the smoke detection function (if fitted).
- Check the Firestart by pressing the test button (if fitted).
- Disconnect the circuit breakers of the capacitor fans and check the high pressure cut-out points on different refrigerant circuits.

Reverse cycle test

This test is designed to check the good operation of the 4-way reversing valves on heat pump reversible systems. Start the reverse cycle by adjusting the cold or hot temperature threshold data according to the indoor and outdoor conditions at the time of test (**menu 3320**)

WITH OPTIONS <i>(Return and supply opening shown on this drawing do not apply to BAC/BAH with electric heater or hot water coil)</i>				BAC	020	030
				BAH		

1D	Down supply air	3	Fresh air	5D	Down hot water entry	8	Extraction
1F	Front supply air	4F	Front main power entry			9	Smoke outlet
2D	Down return air	4D	Down main power entry	71	Outdoor coil inlet	10	Condensate drainage
2F	Front return air	5F	Front hot water entry	70	Outdoor coil outlet		

(*) Total Length (unit + option)

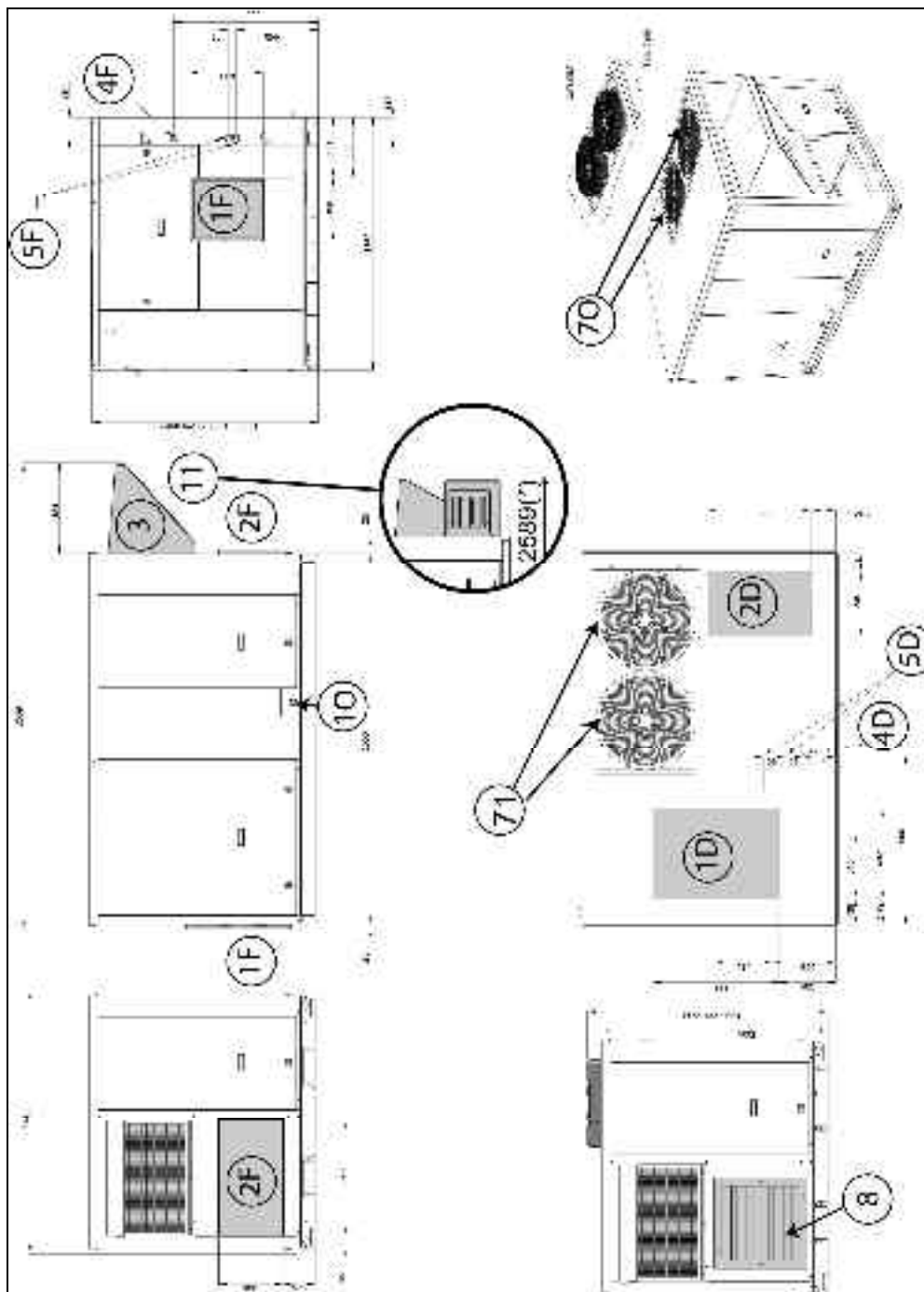

WITH OPTIONS (Return and supply opening shown on this drawing do apply to BAC/BAH with electric heater or hot water coil)					BAG BAM	020	030
--	--	--	--	--	--------------------	------------	------------

1D	Down supply air	3	Fresh air			8	Extraction
1F	Front supply air	4F	Front main power entry	6	Gas supply inlet	9	Smoke outlet
2D	Down return air	4D	Down main power entry	71	Outdoor coil inlet	10	Condensate drainage
2F	Front return air			70	Outdoor coil outlet		

(*) Total Length (unit + option)

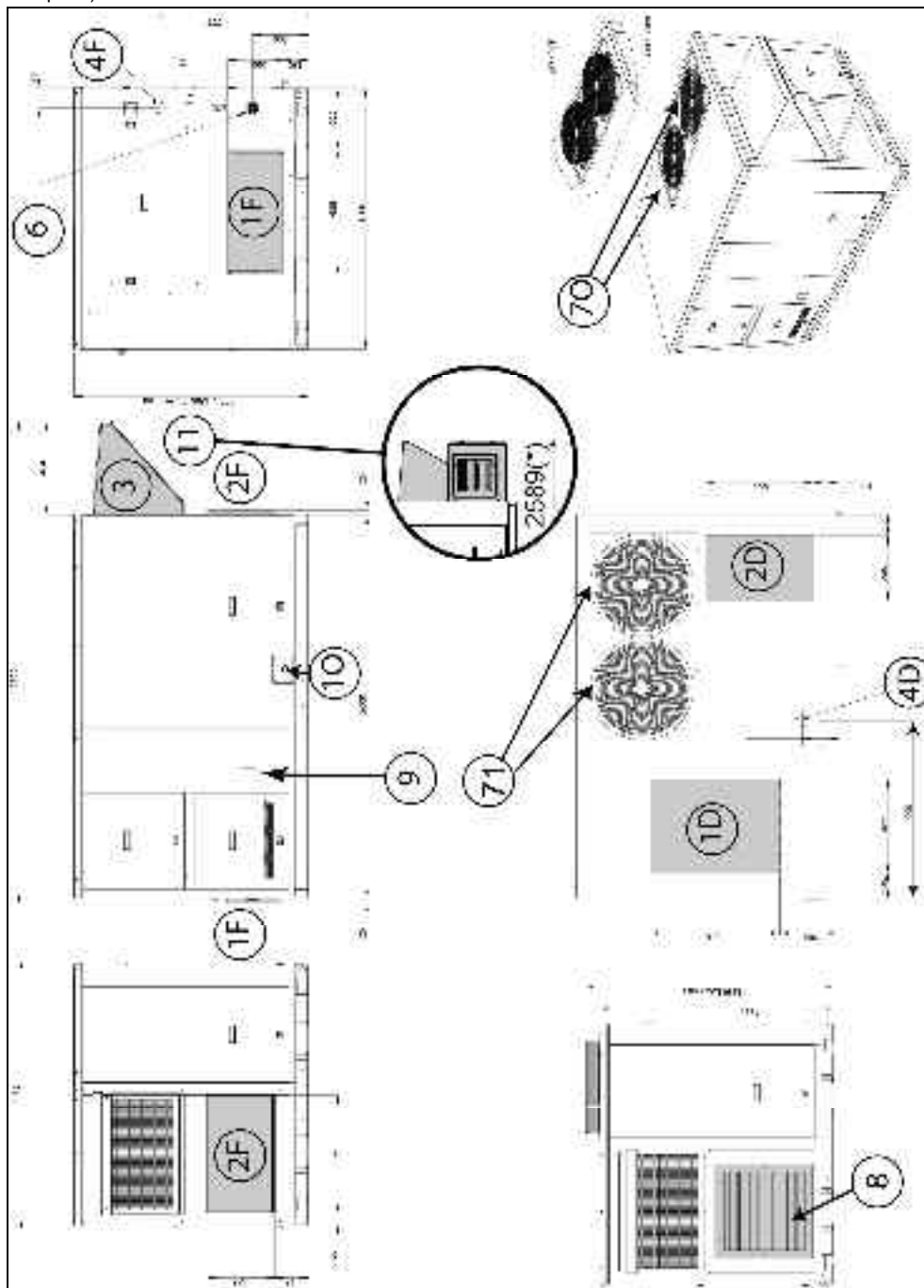

<p>WITH OPTIONS <i>(Return and supply opening shown on this drawing do not apply to BAC/BAH with electric heater or hot water coil)</i></p>	BAC BAH	035
--	--------------------	-----

1D	Down supply air	3	Fresh air	5D	Down hot water entry	8	Extraction
1F	Front supply air	4F	Front main power entry			9	Smoke outlet
2D	Down return air	4D	Down main power entry	71	Outdoor coil inlet	10	Condensate drainage
2F	Front return air	5F	Front hot water entry	70	Outdoor coil outlet		

(*) Total Length (unit + option)

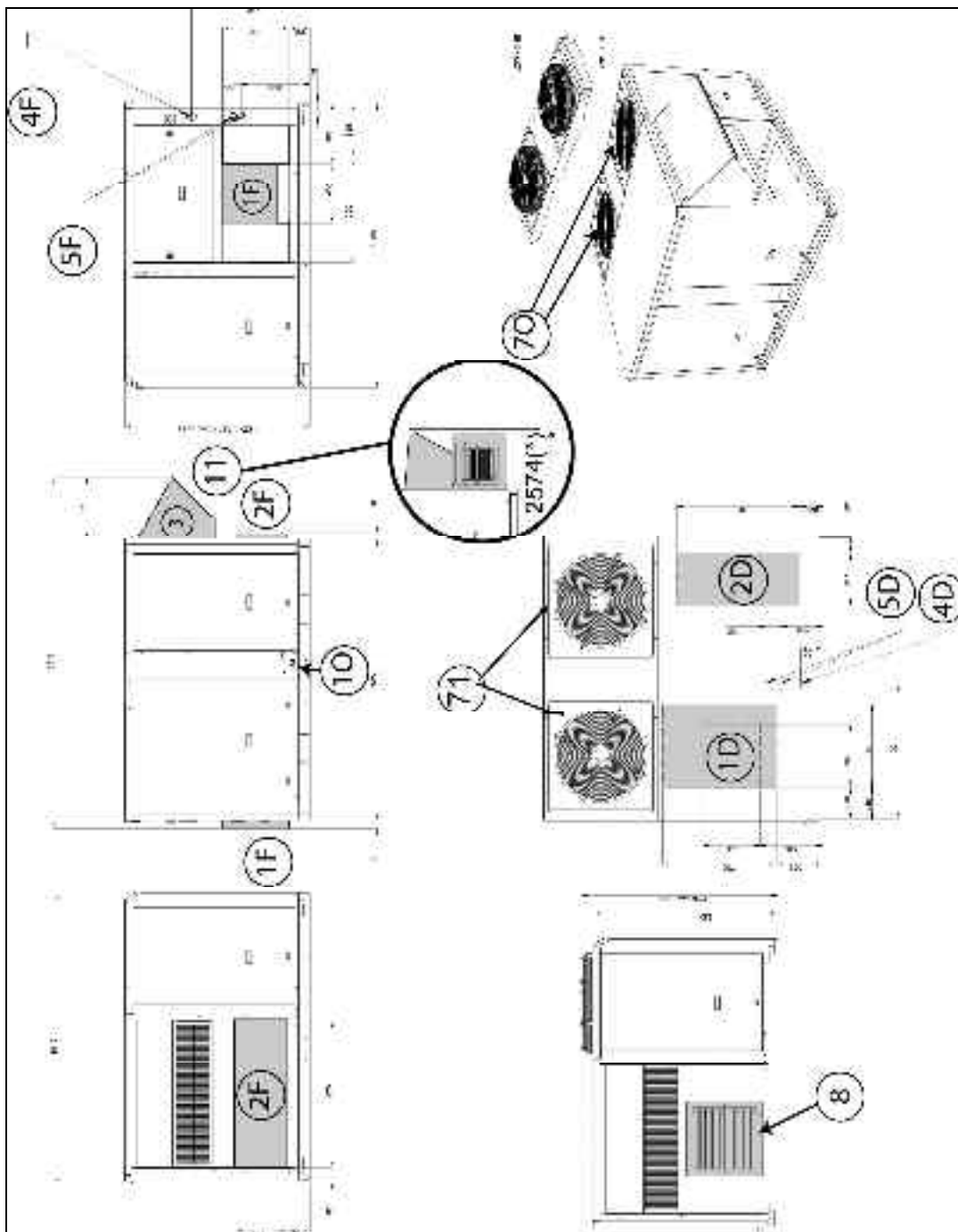

WITH OPTIONS <i>(Return and supply opening shown on this drawing do apply to BAC/BAH with electric heater or hot water coil)</i>						BAG BAM	035
---	--	--	--	--	--	------------	-----

1D	Down supply air	3	Fresh air			8	Extraction
1F	Front supply air	4F	Front main power entry	6	Gas supply inlet	9	Smoke outlet
2D	Down return air	4D	Down main power entry	71	Outdoor coil inlet	10	Condensate drainage
2F	Front return air			70	Outdoor coil outlet		

(*) Total Length (unit + option)

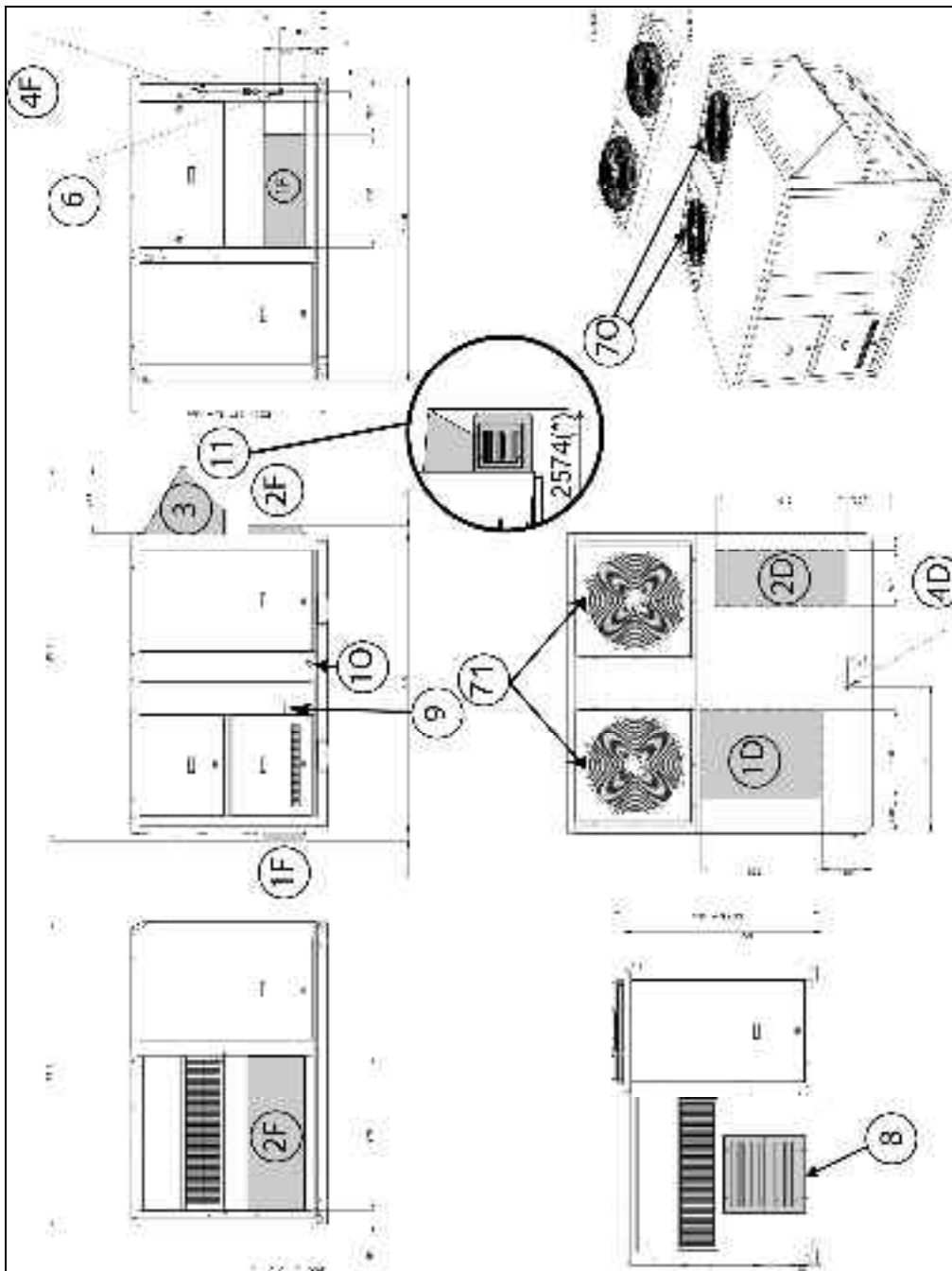

WITH OPTIONS <i>(Return and supply opening shown on this drawing do not apply to BAC/BAH with electric heater or hot water coil)</i>				BAC	045	055
				BAH		

1D	Down supply air	3	Fresh air	5D	Down hot water entry	8	Extraction
1F	Front supply air	4F	Front main power entry			9	Smoke outlet
2D	Down return air	4D	Down main power entry	71	Outdoor coil inlet	10	Condensate drainage
2F	Front return air	5F	Front hot water entry	70	Outdoor coil outlet		

(*) Total Length (unit + option)

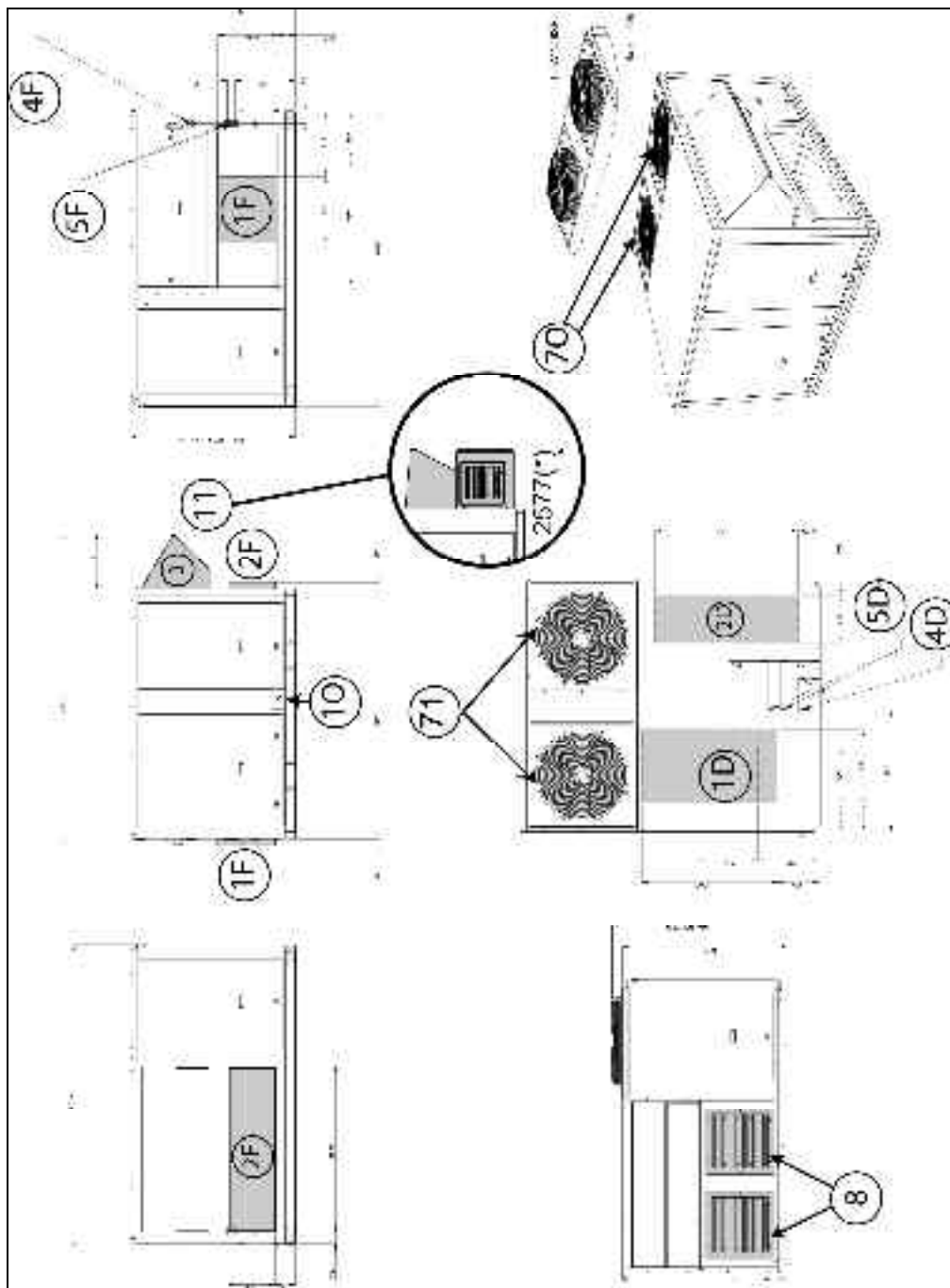

WITH OPTIONS <i>(Return and supply opening shown on this drawing do apply to BAC/BAH with electric heater or hot water coil)</i>					BAG BAM	045	055
---	--	--	--	--	--------------------	------------	------------

1D	Down supply air	3	Fresh air			8	Extraction
1F	Front supply air	4F	Front main power entry	6	Gas supply inlet	9	Smoke outlet
2D	Down return air	4D	Down main power entry	71	Outdoor coil inlet	10	Condensate drainage
2F	Front return air			70	Outdoor coil outlet		

(*) Total Length (unit + option)

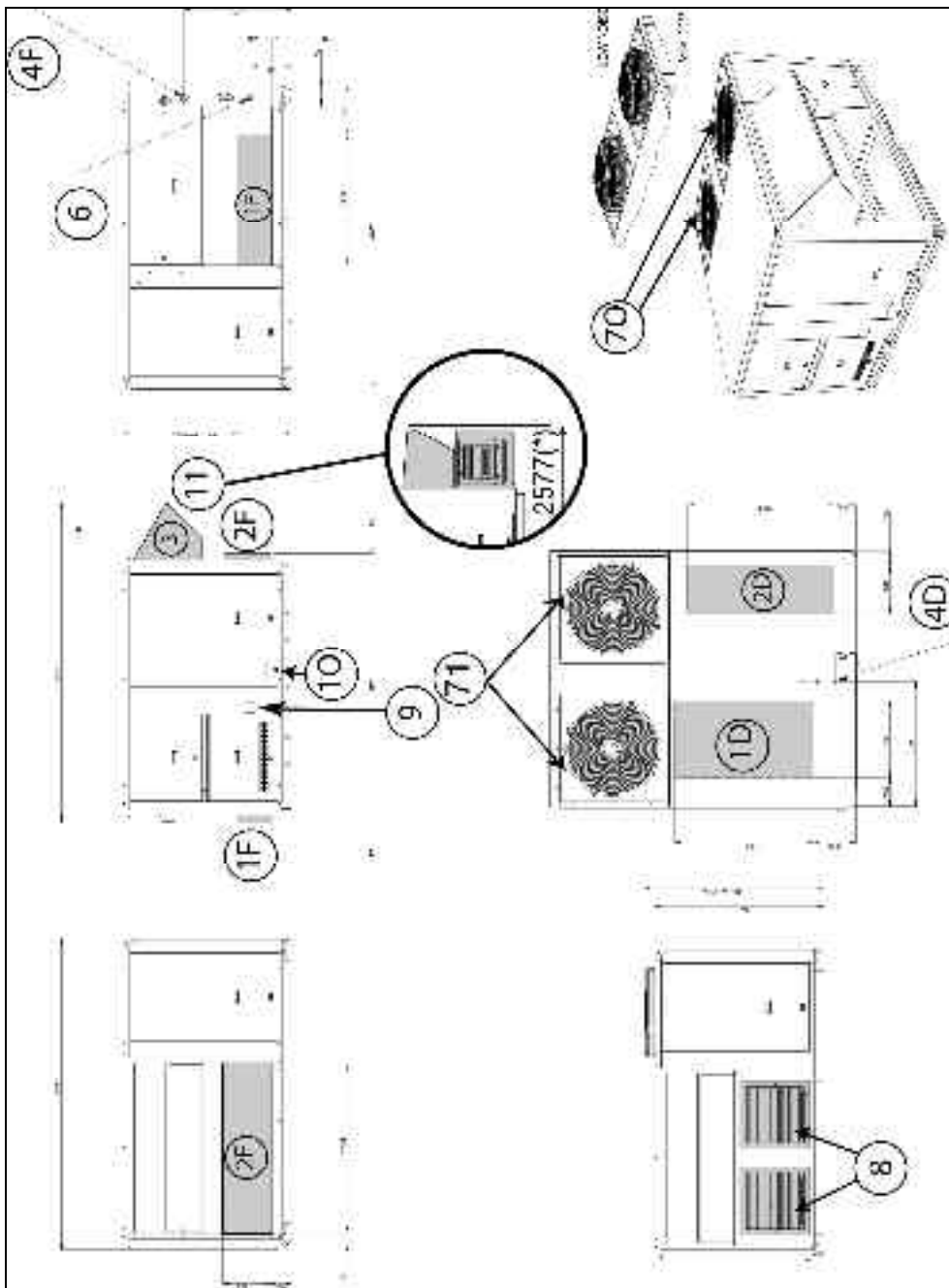

WITH OPTIONS <i>(Return and supply opening shown on this drawing do not apply to BAC/BAH with electric heater or hot water coil)</i>				BAC	065	075
				BAH		

1D	Down supply air	3	Fresh air	5D	Down hot water entry	8	Extraction
1F	Front supply air	4F	Front main power entry			9	Smoke outlet
2D	Down return air	4D	Down main power entry	71	Outdoor coil inlet	10	Condensate drainage
2F	Front return air	5F	Front hot water entry	70	Outdoor coil outlet		

(*) Total Length (unit + option)

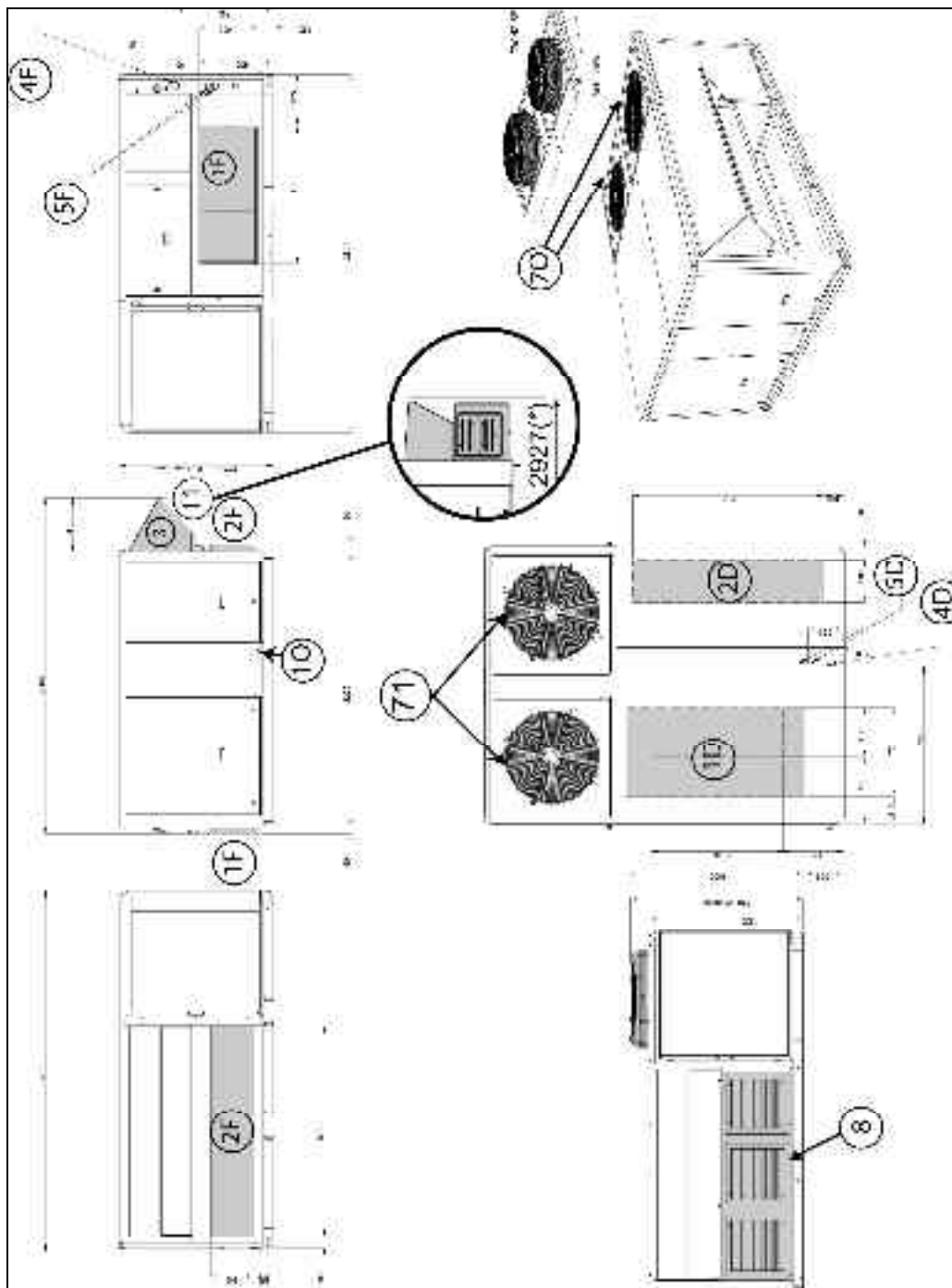

WITH OPTIONS <i>(Return and supply opening shown on this drawing do apply to BAC/BAH with electric heater or hot water coil)</i>					BAG BAM	065	075
--	--	--	--	--	--------------------	------------	------------

1D	Down supply air	3	Fresh air			8	Extraction
1F	Front supply air	4F	Front main power entry	6	Gas supply inlet	9	Smoke outlet
2D	Down return air	4D	Down main power entry	71	Outdoor coil inlet	10	Condensate drainage
2F	Front return air			70	Outdoor coil outlet		

(*) Total Length (unit + option)

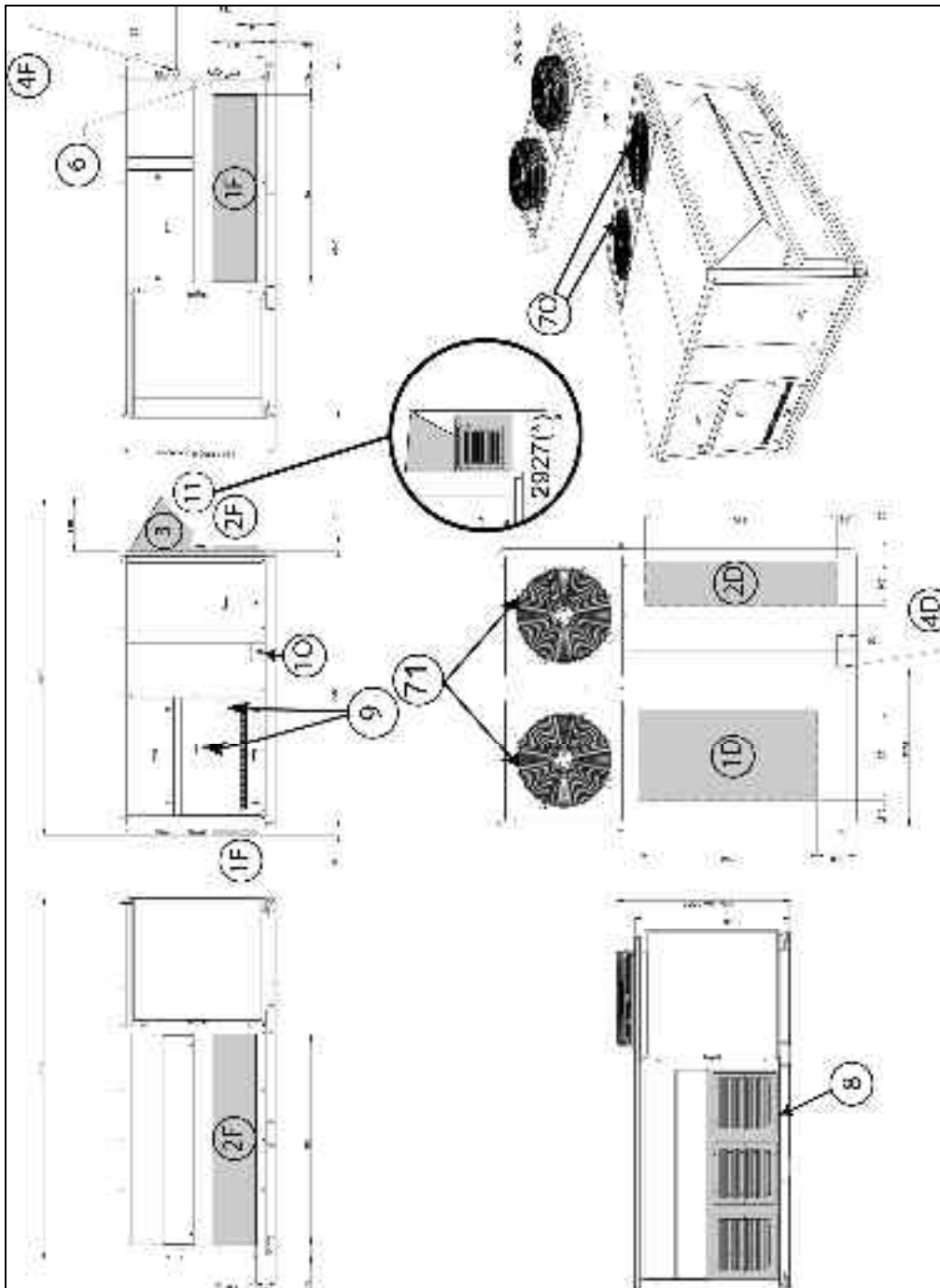

NON ADJUSTABLE ROOFCURB



BAC = Cooling only unit
BAH = Heat pump unit
BAG = Cooling only unit with gas fired heating
BAM = Heat pump unit with gas fired heating

ALL UNITS

1D	Down supply air	8	Main Power Entry 030-035-040-045-050
2D	Return air	8'	Main Power Entry 020-025

Type	Size	A	B	C	D	E	F	G	H	I	J
All	020	1183	1893	691	400	246	246	515	50	1783	1083
	030										
	035	1380	1740	790	400	351	240	675	50	1640	1280
	045										
	055	1630	1740	1050	400	352	229	675	50	1640	1530
	065										
075	2080	2090	1400	400	425	255	720	156	1990	1980	

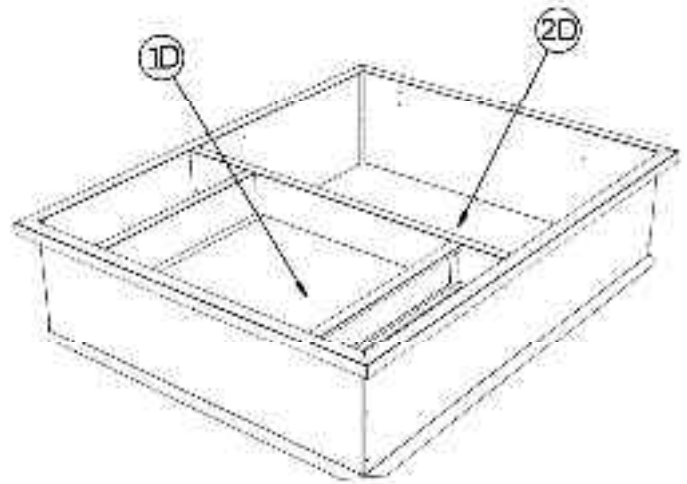
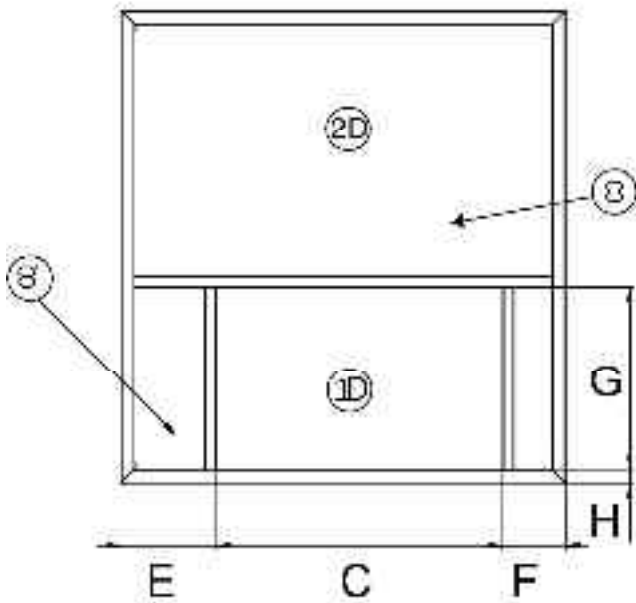
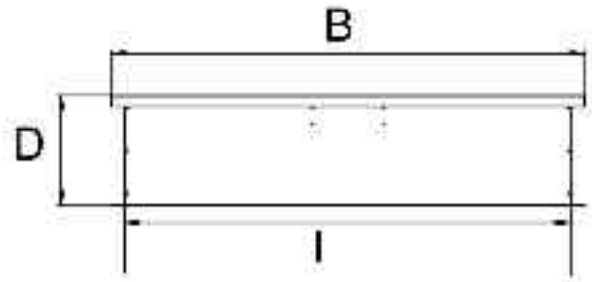
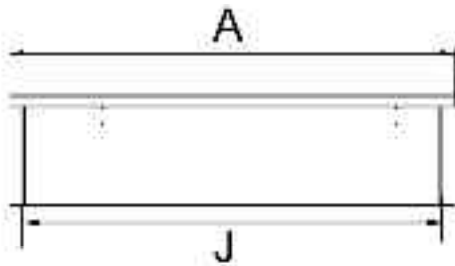

Roof opening I x J

020 030

	A	B
BAC / BAH _BAG / BAM or BAC / BAH with auxiliary heating	247	691

1D	Down supply air	4D	Down main power entry
2D	Down return air	5D	Down hot water entry
8	Main power entry		

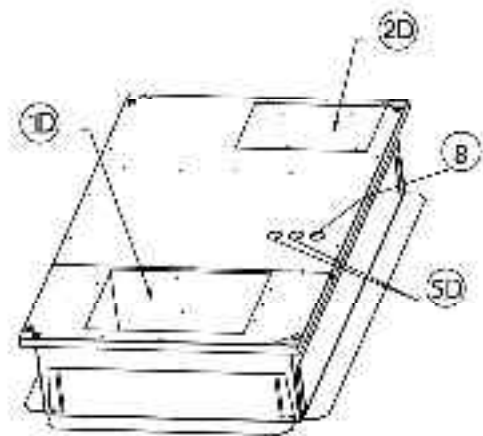
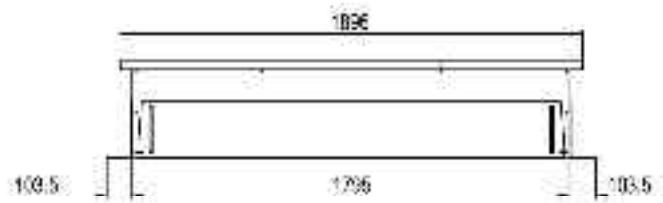
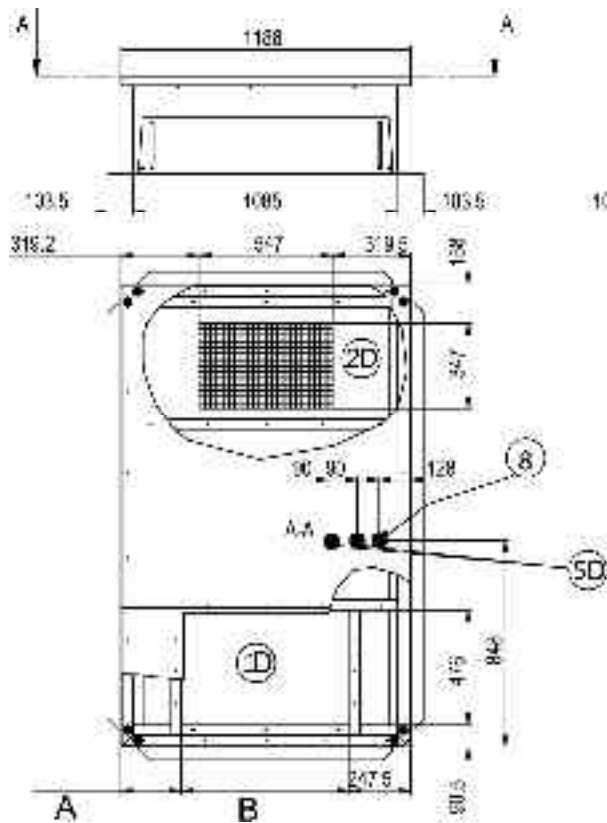

Roof opening 1795 x 1085

035

	A	B	C	D
BAC / BAH _BAG / BAM or BAC / BAH with auxiliary heating	636	351	790	241

1D	Down supply air	4D	Down main power entry
2D	Down return air	5D	Down hot water entry
8	Main power entry		

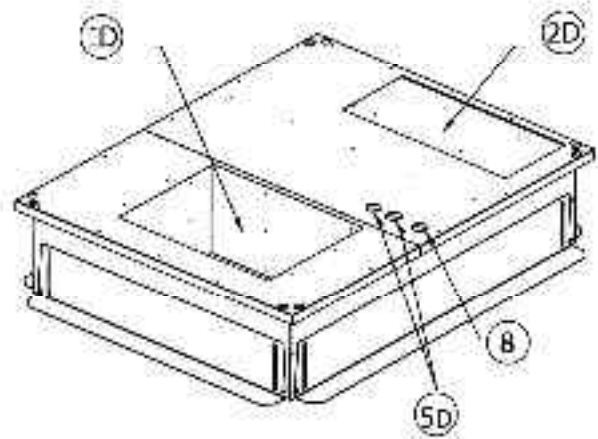
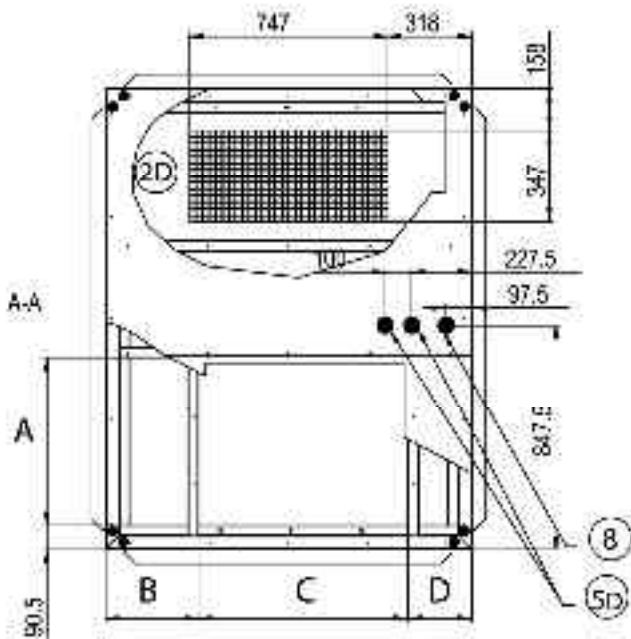
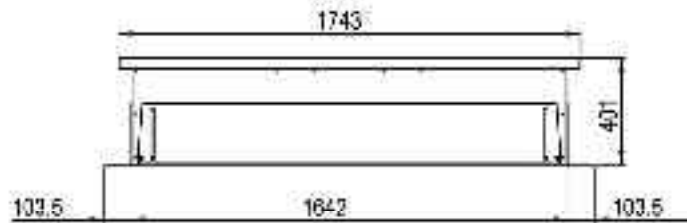
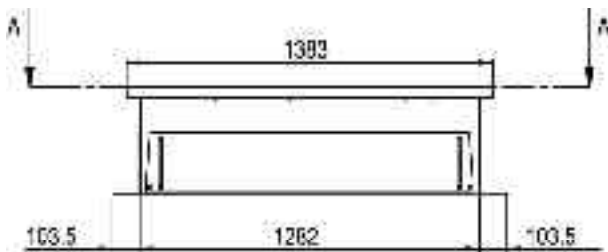

Roof opening 1642 x 1282

045 055

	A	B	C	D
BAC / BAH _ BAG / BAM or BAC / BAH with auxiliary heating	352	1050	230	637

1D	Down supply air	4D	Down main power entry
2D	Down return air	5D	Down hot water entry
8	Main power entry		

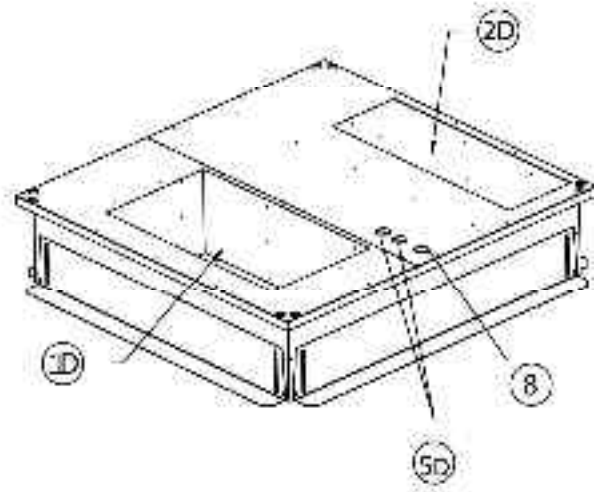
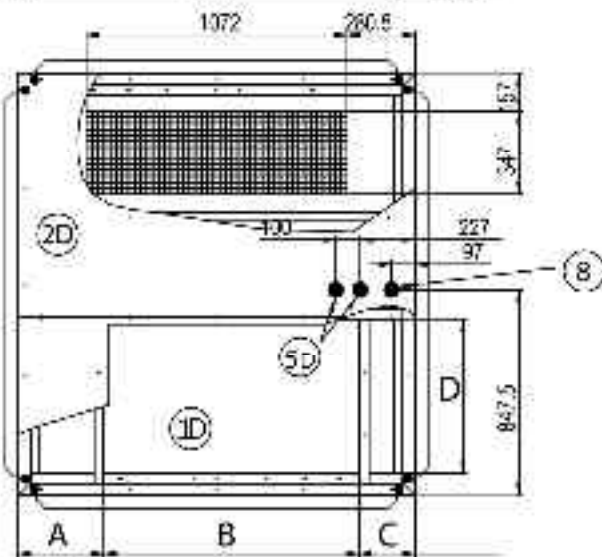
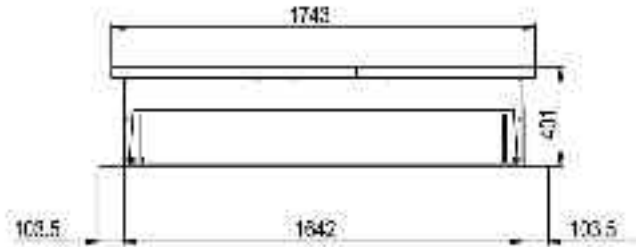
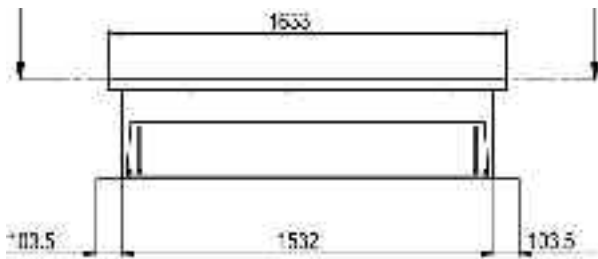

Roof opening 1642 x 1532

BAC BAG
BAH BAM

065 075

1D	Down supply air	4D	Down main power entry
2D	Down return air	5D	Down hot water entry
8	Main power entry		

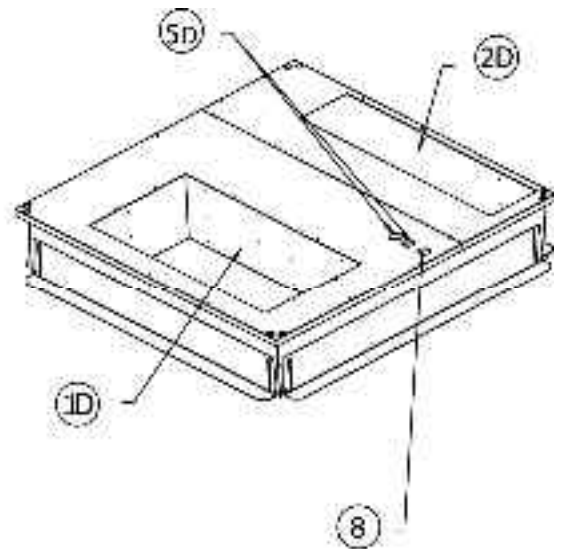
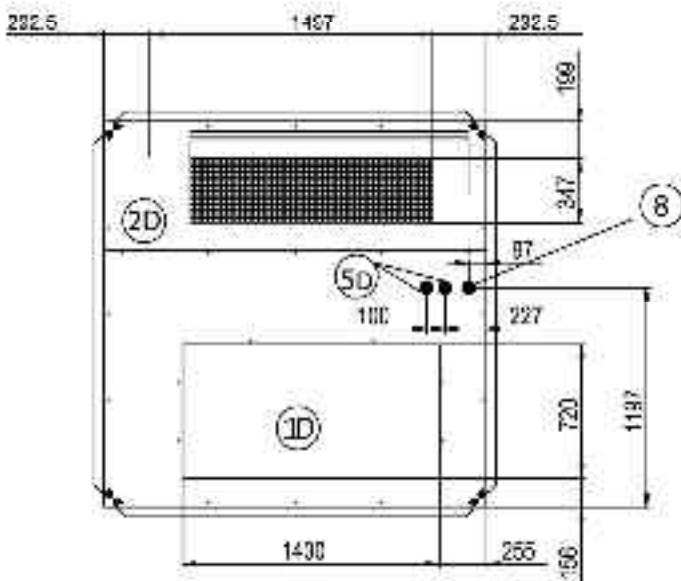
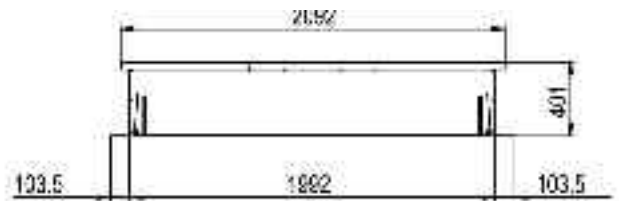
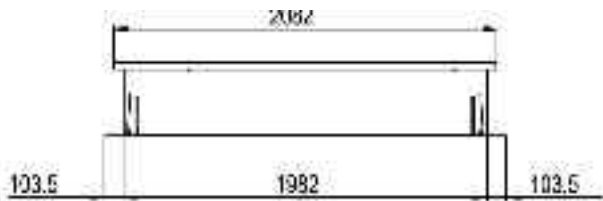

BAC **BAG**
BAH **BAM**

020 **030**

1F	Front supply air	2F	Front return air
1F'		2F'	

(*) This roofcurb is also necessary for all cooling only or heatpump rooftop with auxiliary electric heater or hot water coil.

WARNING : ONLY ONE OF THE 4 FOLLOWINGS POSSIBILITIES :

2F - 1F / 2F - 1F'

2F' - 1F / 2F' - 1F'

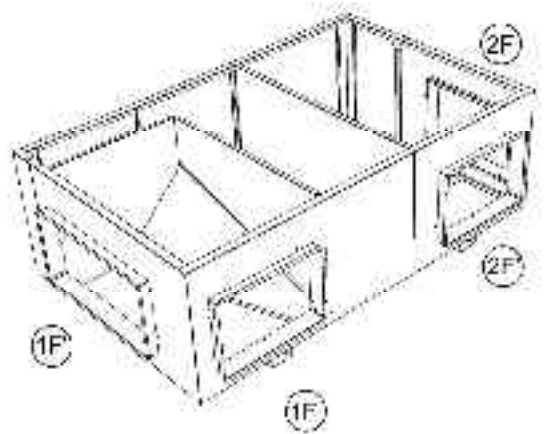
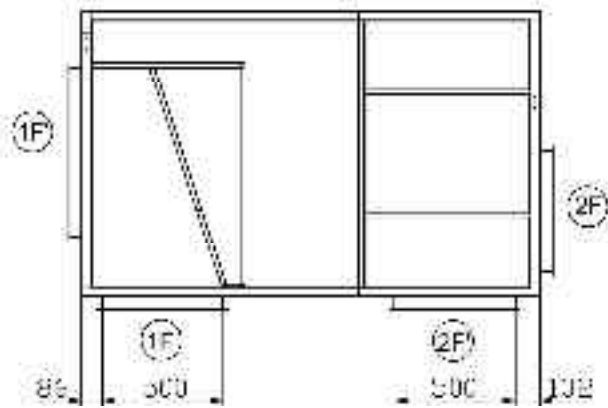
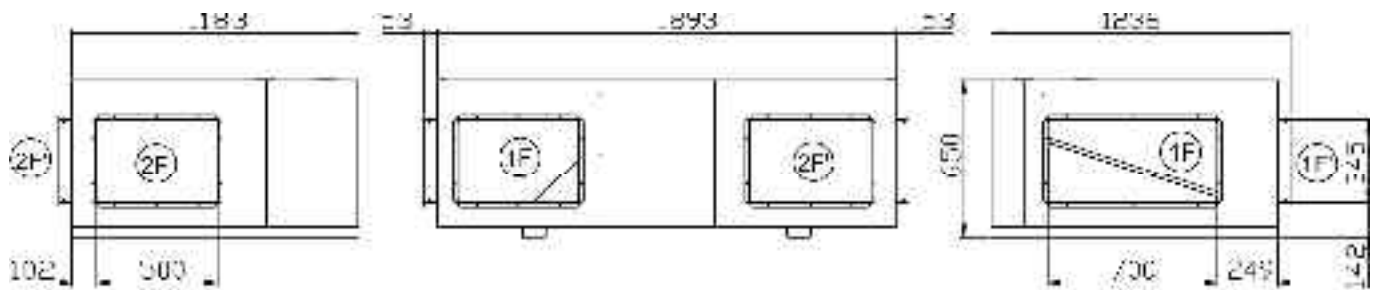

BAC **BAG**
BAH **BAM**

035

1F	Front supply air	2F	Front return air
1F'		2F'	

(*) This roofcurb is also necessary for all cooling only or heatpump rooftop with auxiliary electric heater or hot water coil.

WARNING : ONLY ONE OF THE 4 FOLLOWINGS POSSIBILITIES :

2F - 1F / 2F - 1F'

2F' - 1F / 2F' - 1F'

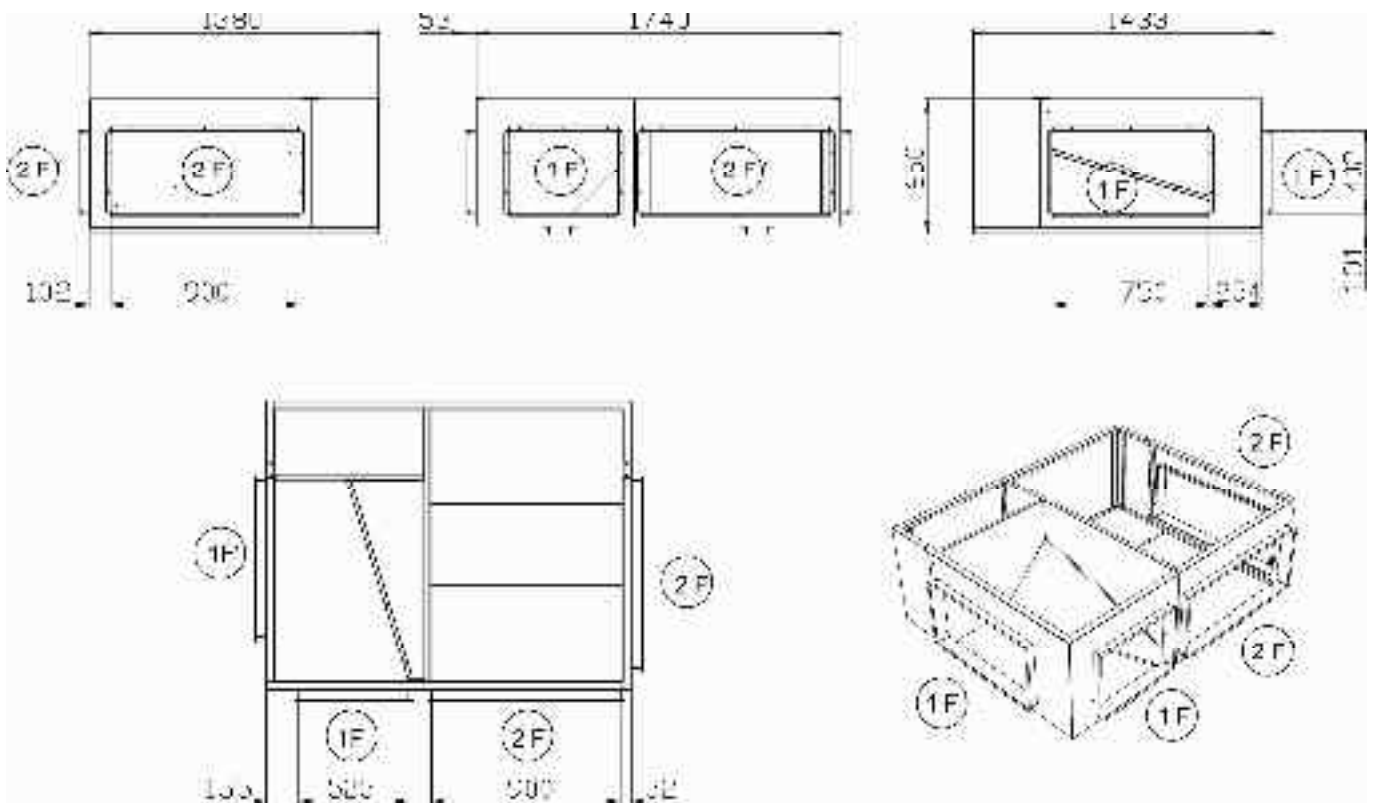

BAC BAG
BAH BAM

045 055

1F	Front supply air	2F	Front return air
1F'		2F'	

(*) This roofcurb is also necessary for all cooling only or heatpump rooftop with auxiliary electric heater or hot water coil.

WARNING : ONLY ONE OF THE 4 FOLLOWINGS POSSIBILITIES :

2F - 1F / 2F' - 1F'

2F' - 1F / 2F' - 1F'

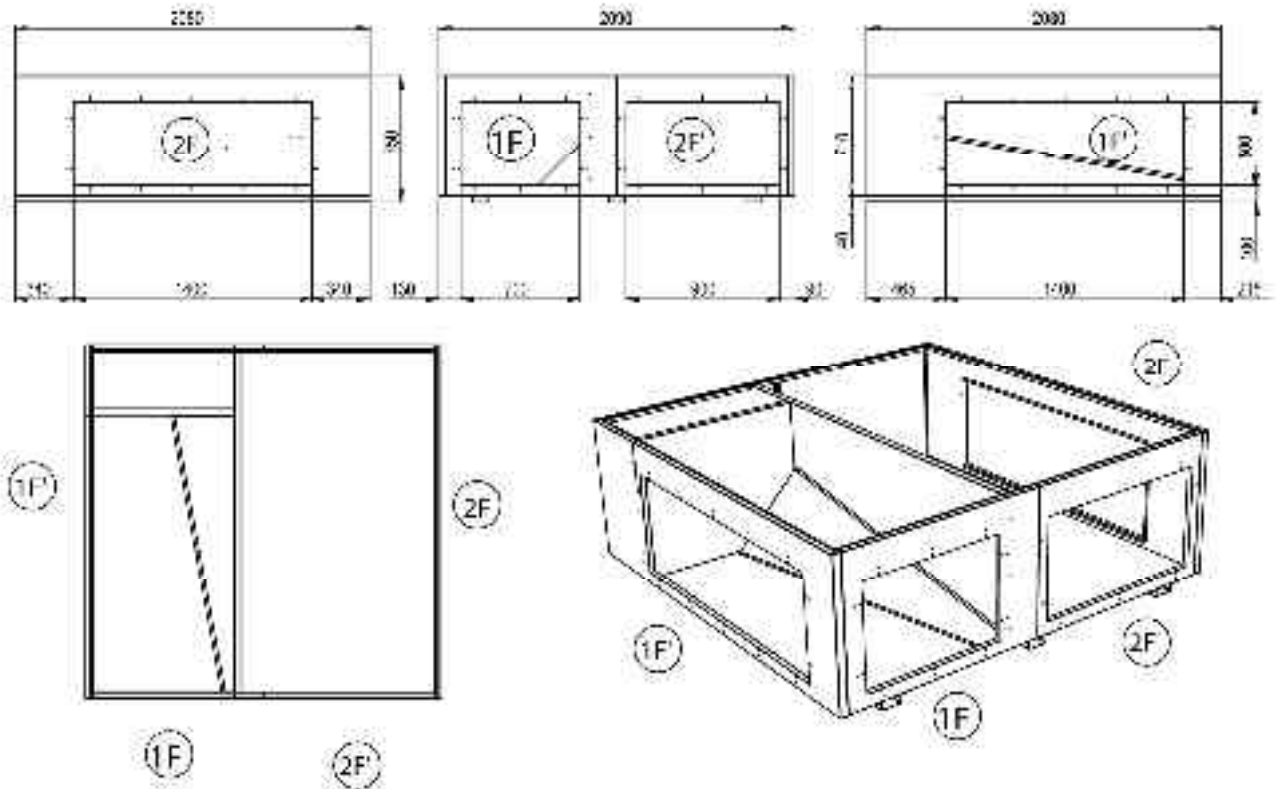

BAC **BAG**
BAH **BAM**

065 **075**

1F	Front supply air	2F	Front return air
1F'		2F'	

WARNING : ONLY ONE OF THE 4 FOLLOWINGS POSSIBILITIES :

2F - 1F / 2F - 1F'

2F' - 1F / 2F' - 1F'

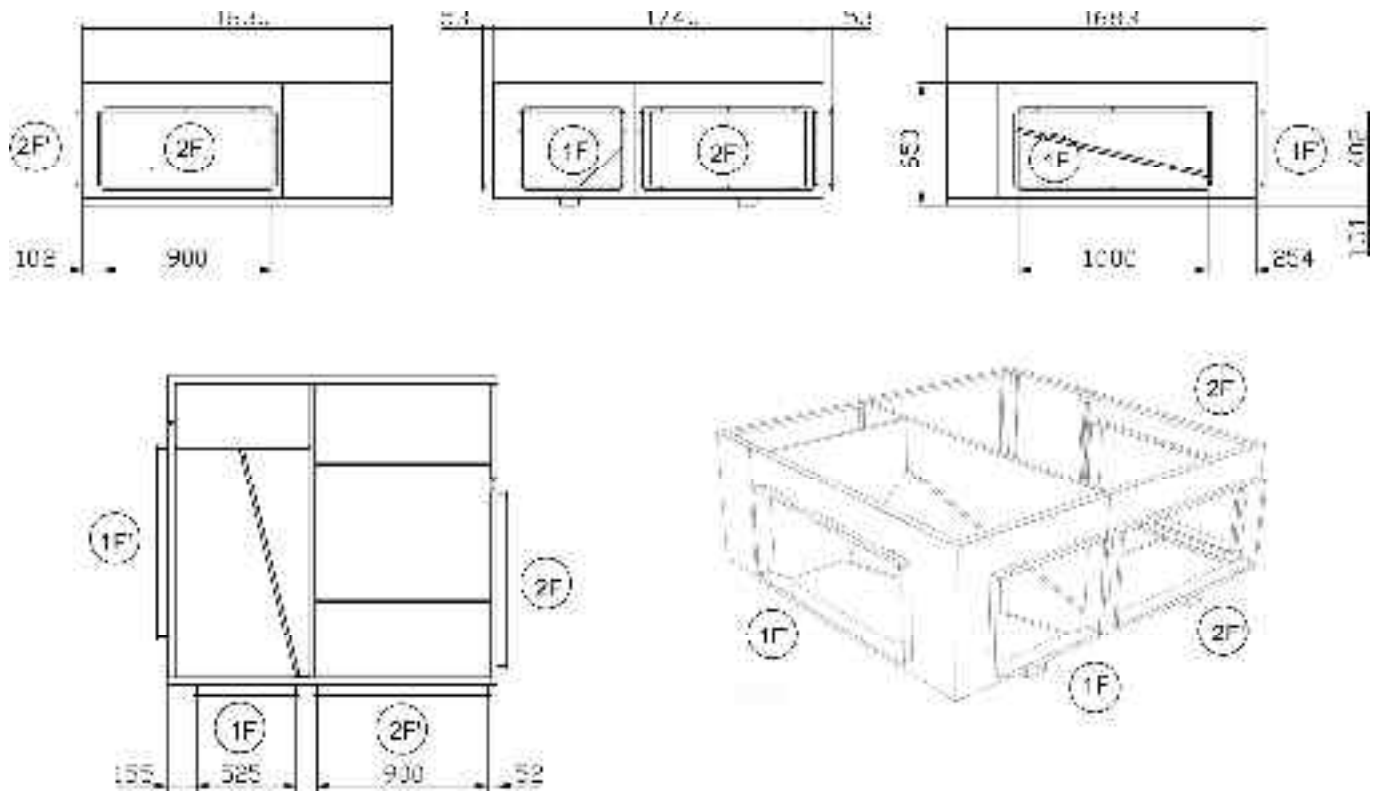

020 030

	A	B
BAC / BAH without auxiliary heating	395	542
BAG / BAM or BAC / BAH with auxiliary heating	691	246

1D	Down supply air	4D	Down main power entry
2D	Down return air	5D	Down hot water entry
8	Main power entry	9	Exhaust

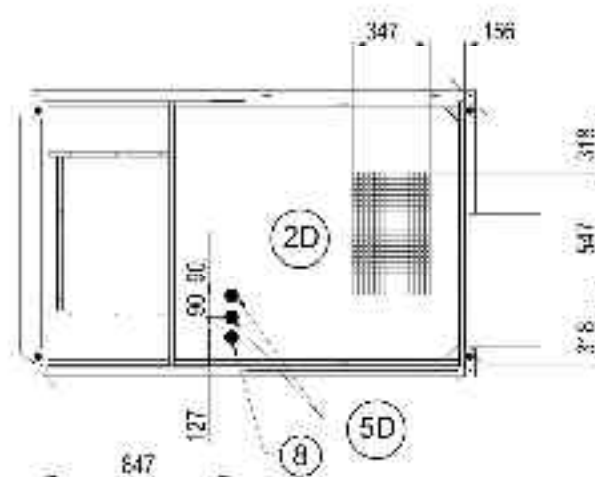
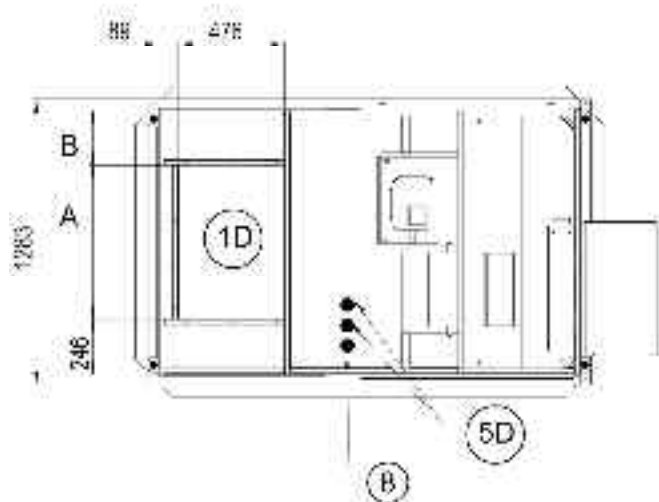
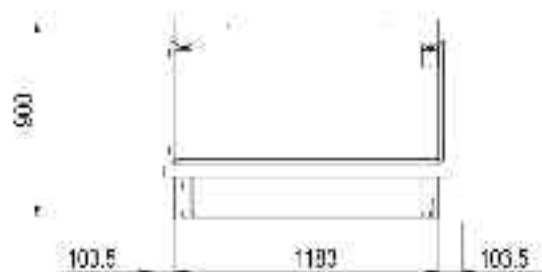
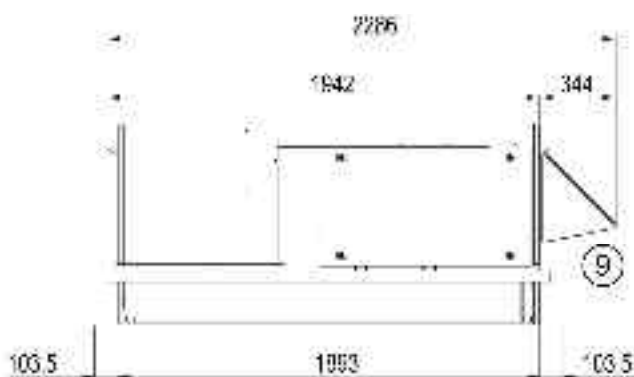

035

	A	B	C
BAC / BAH without auxiliary heating	632	400	348
BAG / BAM or BAC / BAH with auxiliary heating	350	790	240

1D	Down supply air	4D	Down main power entry
2D	Down return air	5D	Down hot water entry
8	Main power entry	9	Exhaust

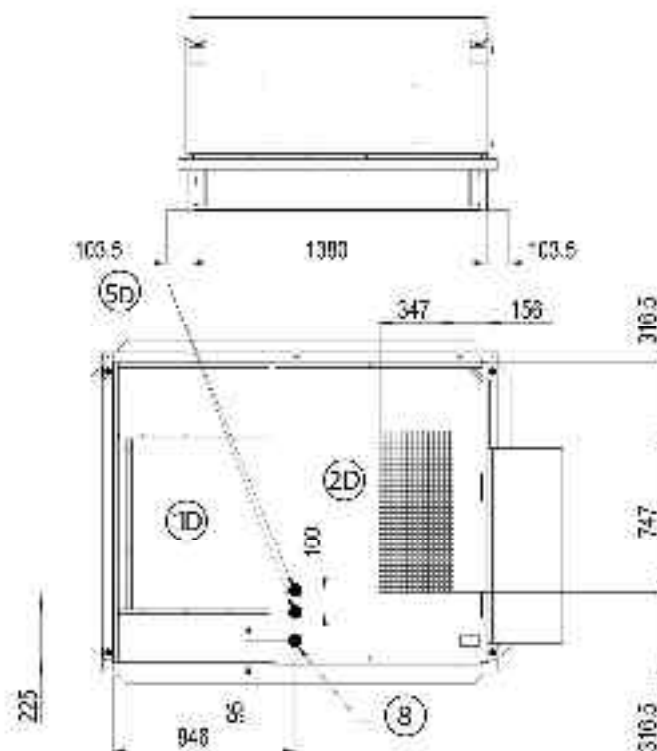
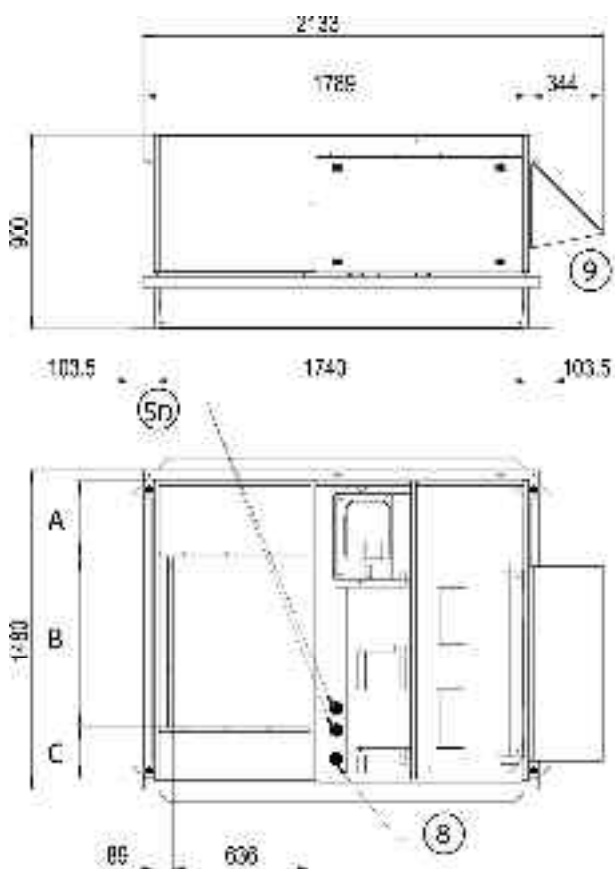

045 055

	A	B	B	C
BAC / BAH without auxiliary heating	749	500	382	496
BAG / BAM or BAC / BAH with auxiliary heating	351	1050	229	636

1D	Down supply air	4D	Down main power entry
2D	Down return air	5D	Down hot water entry
8	Main power entry	9	Exhaust

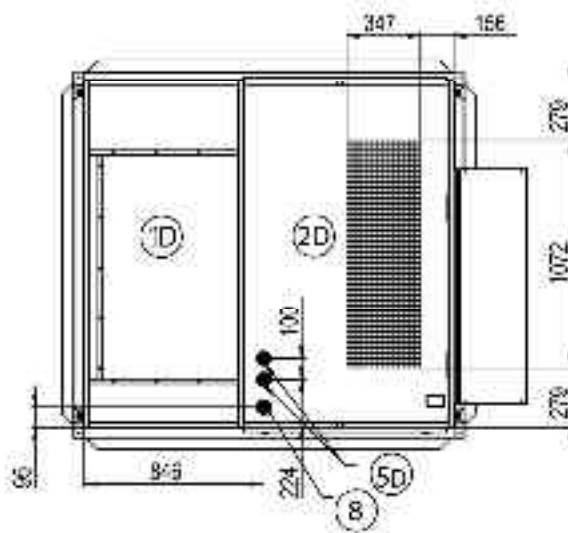
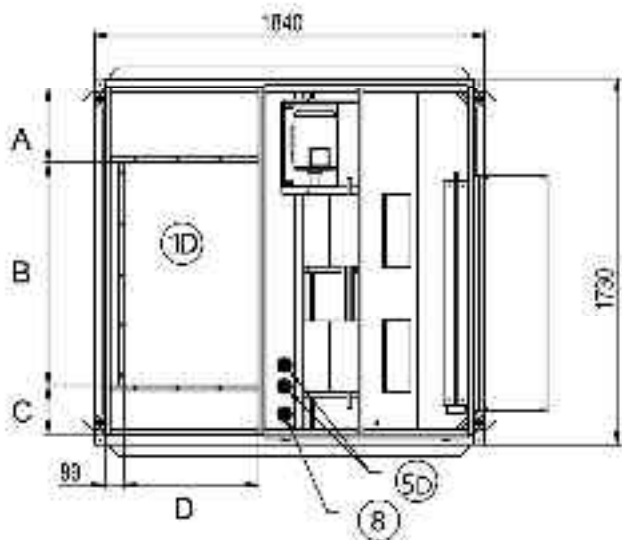
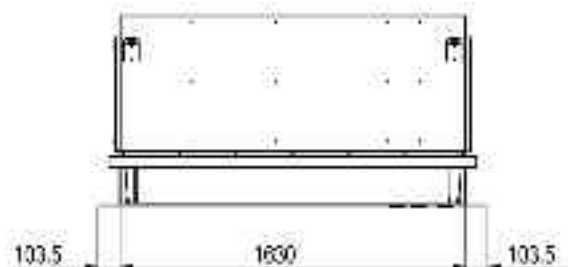
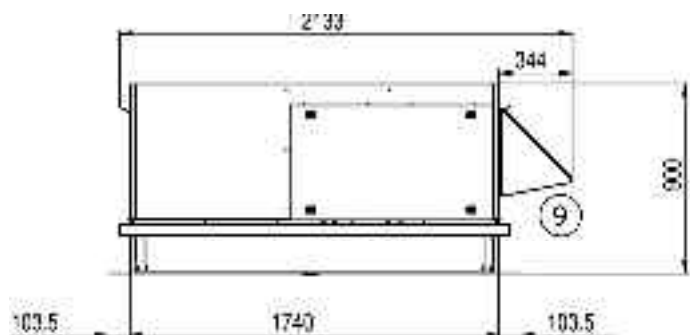

BAC **BAG**
BAH **BAM**

020 **030** **035**

1D	Down supply air	4D	Down main power entry
2D	Down return air	5D	Down hot water entry
8	Main power entry	9	Exhaust

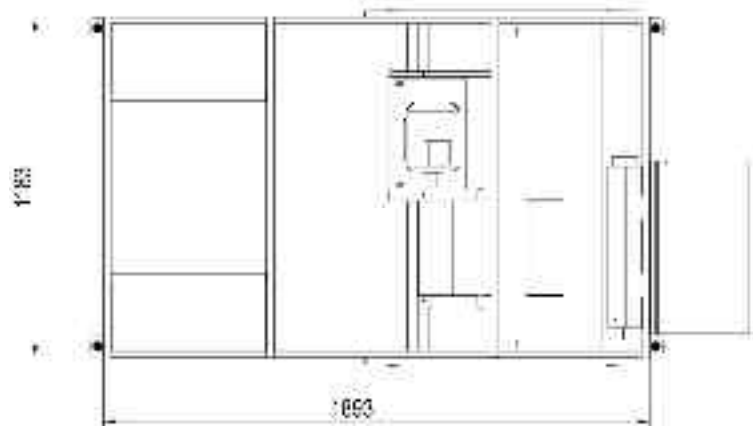
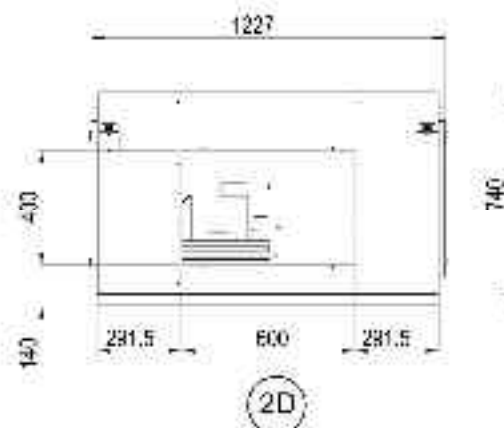
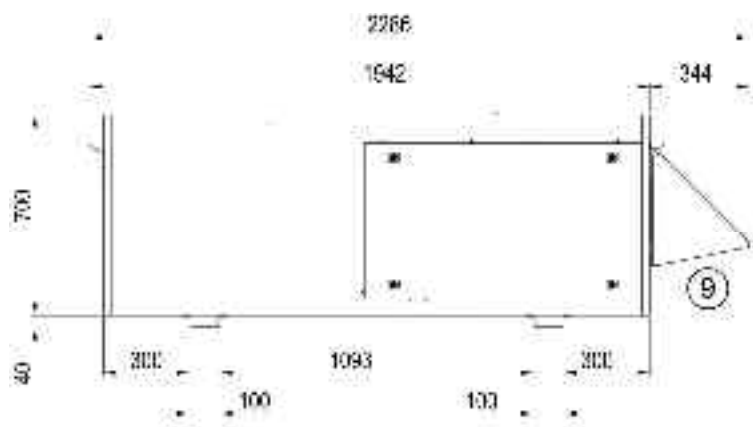

BAC BAG
BAH BAM

045 055

1D	Down supply air	4D	Down main power entry
2D	Down return air	5D	Down hot water entry
8	Main power entry	9	Exhaust

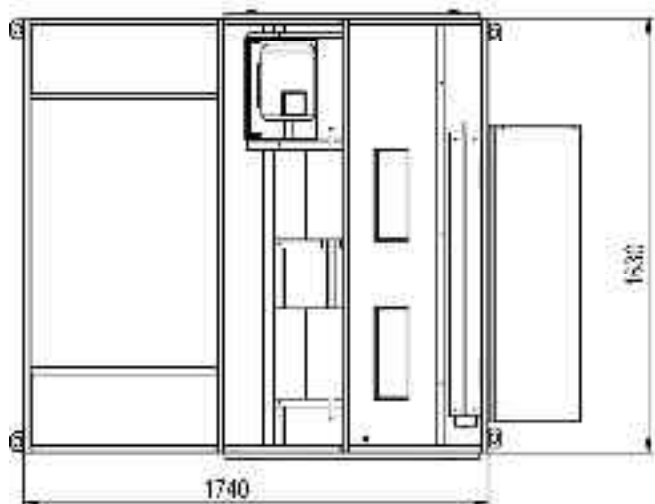
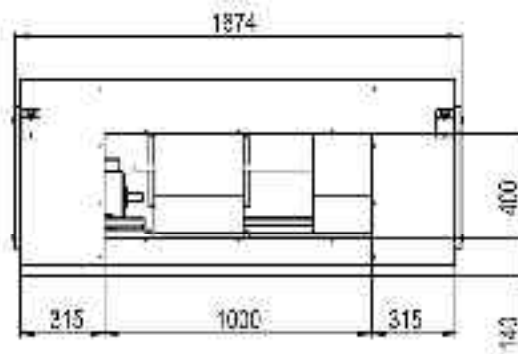
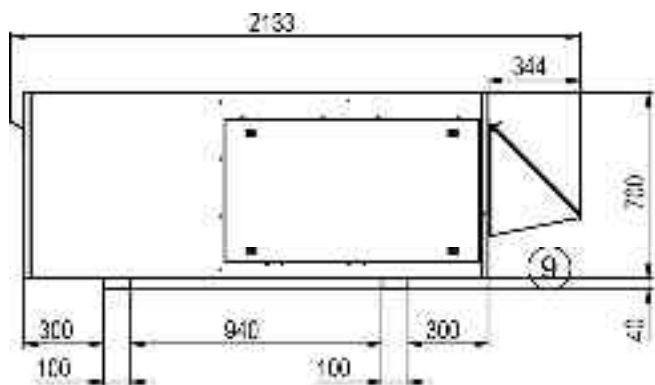

BAC BAG
BAH BAM

065 075

1D	Down supply air	4D	Down main power entry
2D	Down return air	5D	Down hot water entry
8	Main power entry	9	Exhaust

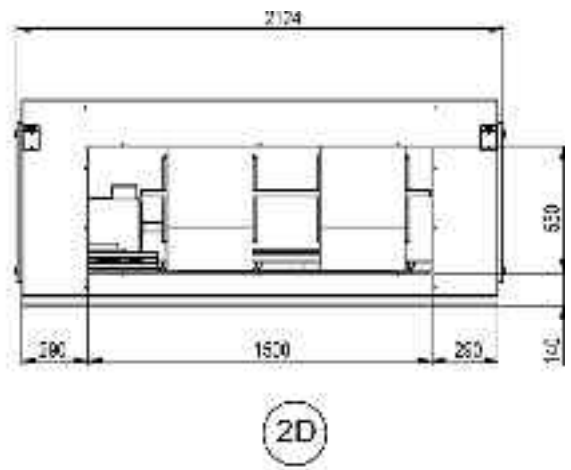
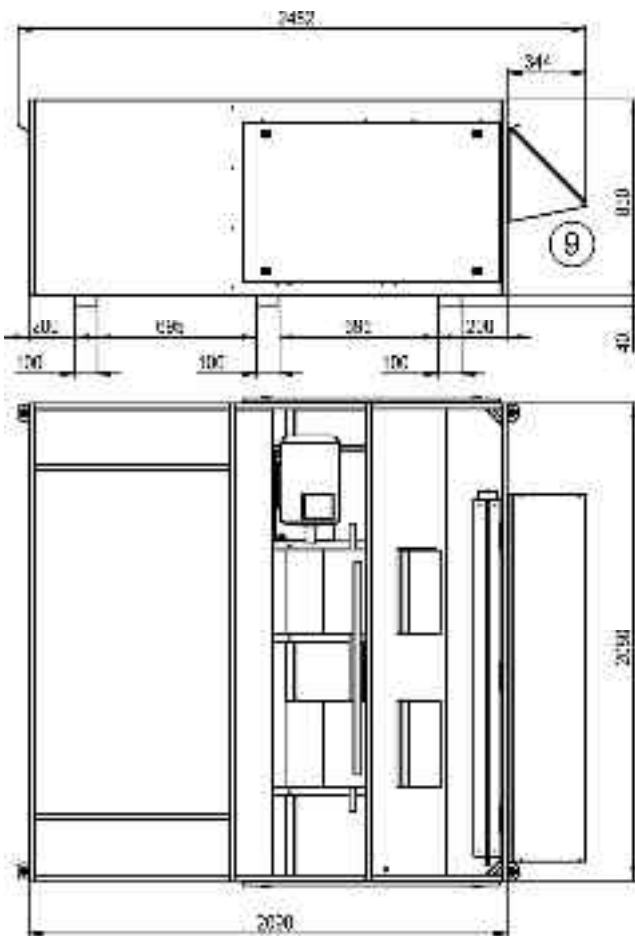

BAC BAG
BAH BAM

065 075

1D	Down supply air	4D	Down main power entry
2D	Down return air	5D	Down hot water entry
8	Main power entry	9	Exhaust

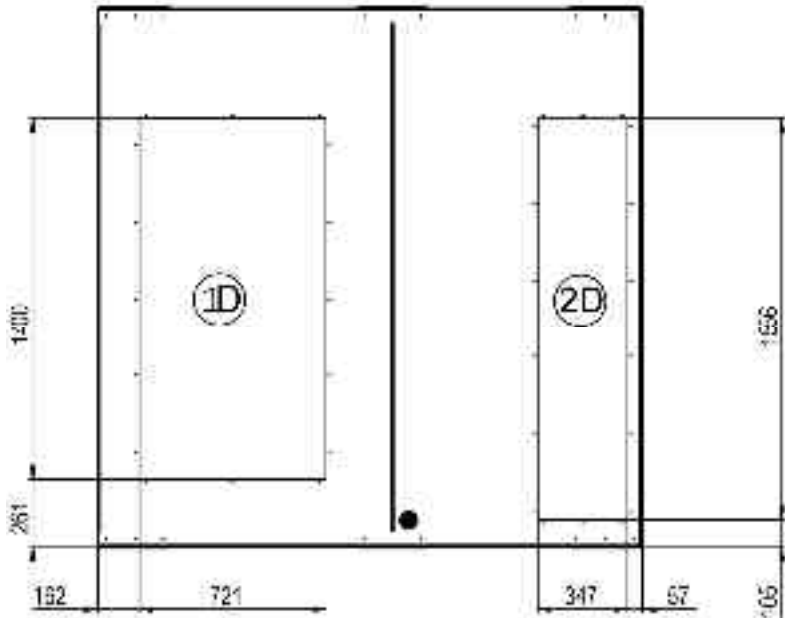
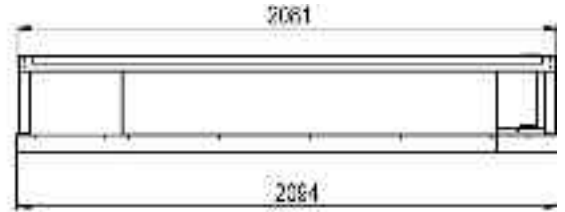
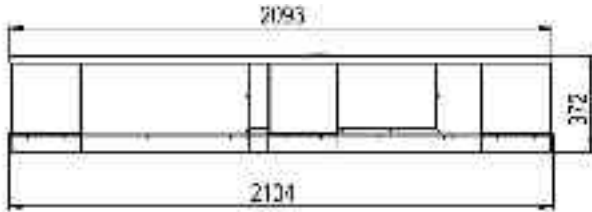

020

030



Part 1 and 2 are supplied loose + Fresh air and extracted air hood closed

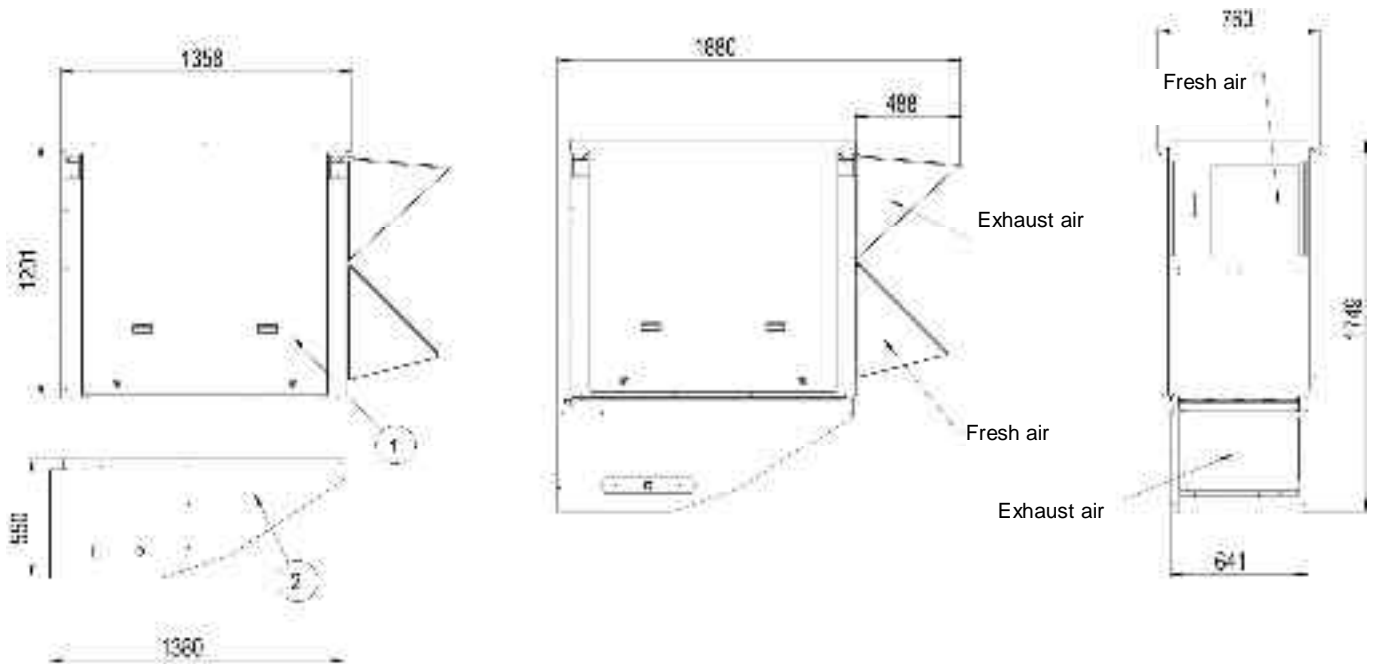



Part 1 and 2 are supplied loose + Fresh air and extracted air hood closed

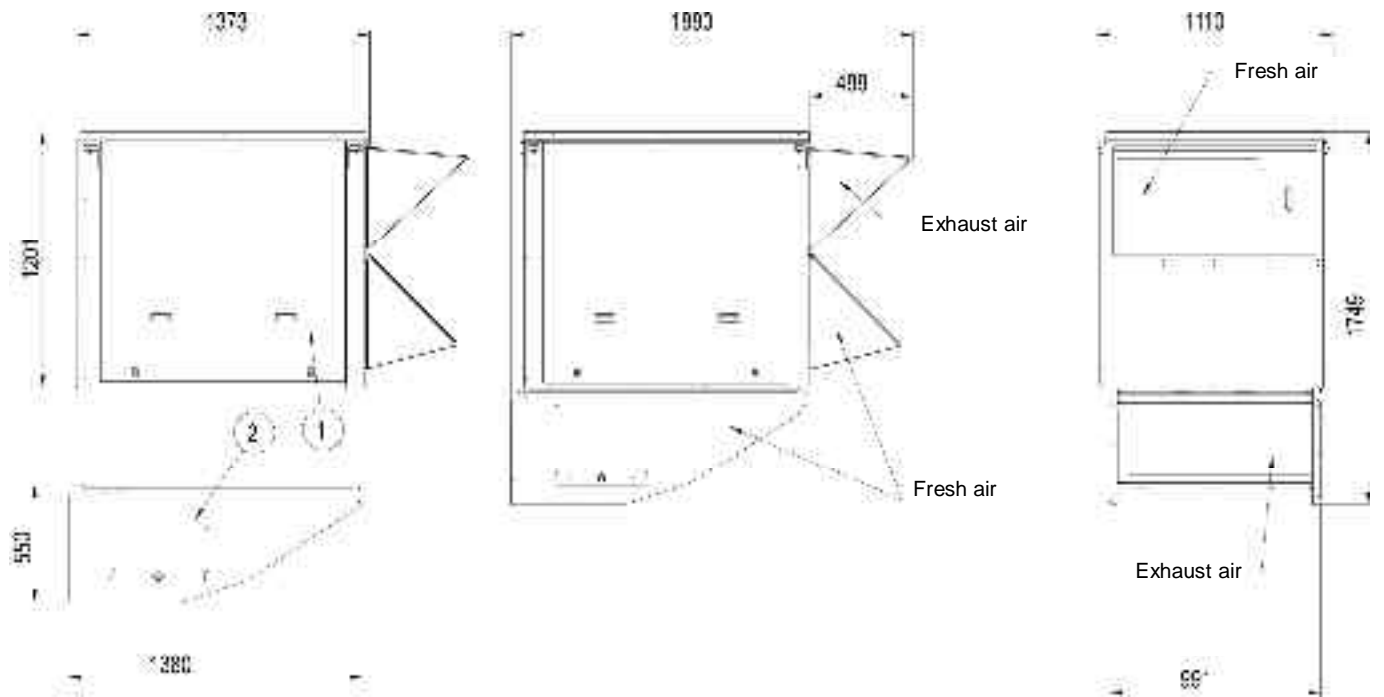

045 055

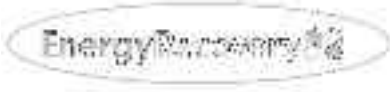

Part 1 and 2 are supplied loose + Fresh air and extracted air hood closed

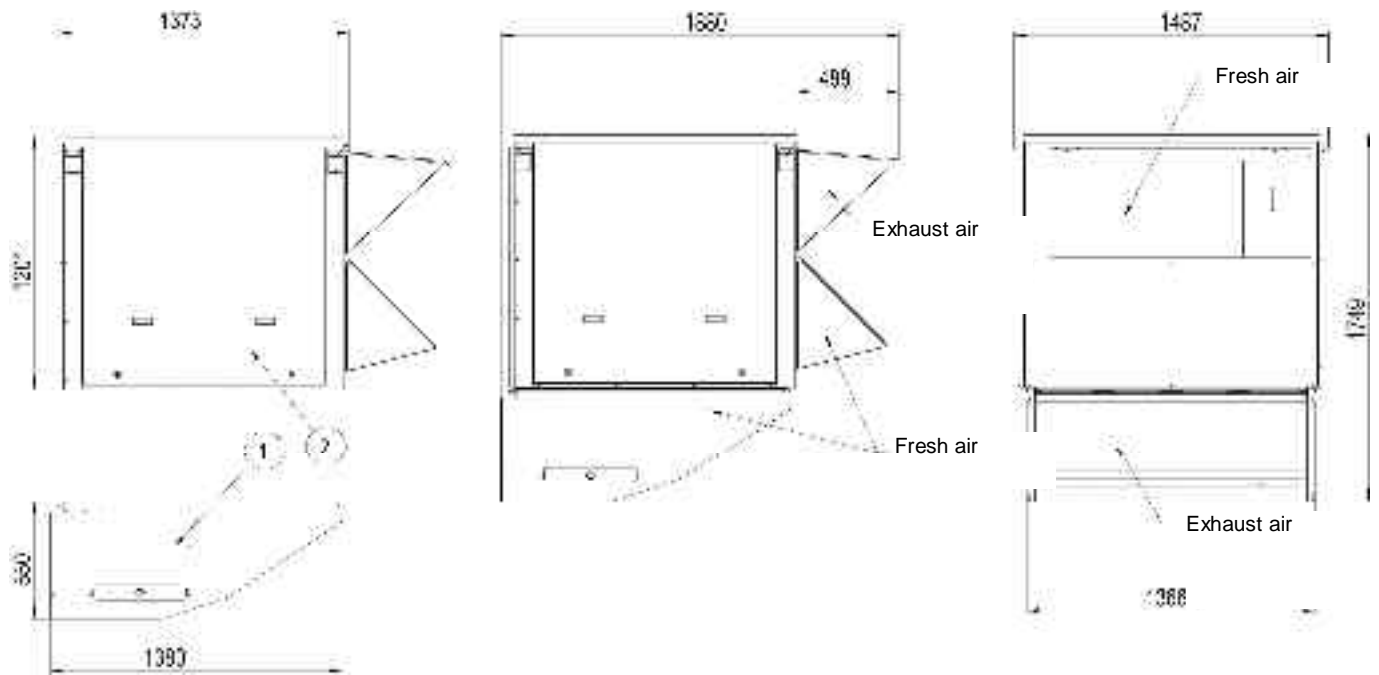



Part 1 and 2 are supplied loose + Fresh air and extracted air hood closed

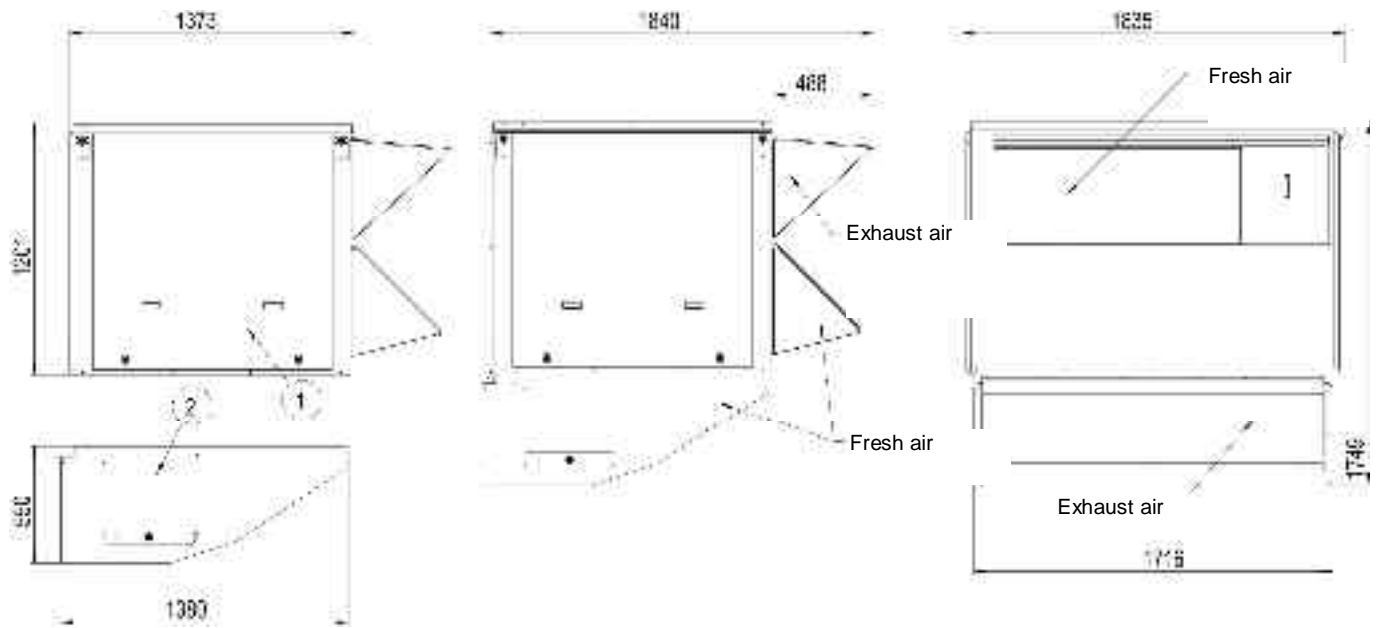

BELT TENSION

On delivery, the drive belts are new and correctly tensioned. After the first 50 operating hours check and adjust the tension. 80% of the total elongation of belts is generally produced during the first 15 hours of operation.

Before adjusting the tension, make sure that the pulleys are correctly aligned.

To tension the belt, set the height of motor support plate by moving the plate adjustment screws.

The recommended deflection is 20 mm per metre from centre to centre.

Check that according to the diagram below (figure 37), the following ratio remains the same.

$$\frac{A \text{ (mm)}}{P \text{ (mm)}} = 20$$

The belts should always be replaced when:

- The disk is set to maximum,
- The belt rubber is worn or the wire is visible.

Replacement belts must have the same rated size as the ones they are replacing. If a transmission system has several belts, they must all be from the same manufacturing batch (compare serial numbers).

NOTE:

An under-tensioned belt will slip, heat and wear prematurely. On the other hand, if a belt is over-tensioned, the pressure on the bearings will cause them to over-heat and wear prematurely. Incorrect alignment will also cause the belts to wear prematurely.



Fig.36

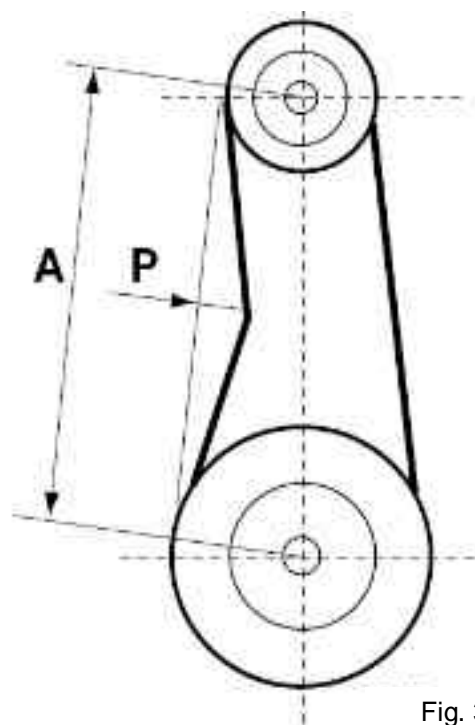

Fig. 37

MOUNTING AND ADJUSTING PULLEYS

Fan pulley removal

Remove the 2 screws and put one of them in the extraction threaded screw.

Screw in fully. The hub and the pulley will separate from each other.

Remove the hub and the pulley by hand without damaging the machine.



Fig. 38

Fan pulley installation

Clean and de-grease the shaft, hub and conical bore of the pulley. Lubricate the screws and install the hub and pulley. Position the screws without turning them.

Place the assembly on the shaft and screw in the screws alternatively and evenly. Using a mallet or a hammer with a wooden wedge, tap on the face of the hub to keep the assembly in place. Torque the screws to 30 Nm.

Take the pulley in both hands and shake it vigorously to make sure everything is in place.

Fill the holes with grease for protection.

NOTE : During installation, the key should never protrude out of its groove.

After 50 operating hours, check that the screws are still in place.

MOTOR PULLEY INSTALLATION AND REMOVAL

The pulley is held in position by the key and a screw located in the groove. After unlocking, removing this screw by pulling against the shaft spindle (if necessary, use a mallet and tap uniformly on the hub to remove it).

To assemble, proceed in the reverse order after having cleaned and de-greased the motor shaft and the pulley bore.

PULLEYS ALIGNMENT

After adjusting one or both of the pulleys, check the transmission alignment using a ruler placed on the inner face of the two pulleys.

NOTE: The warranty may be affected if any major modification is made to the transmission without obtaining our agreement beforehand.



Fig.39



Fig. 40

The actual resistance of ductwork systems is not always identical to the calculated theoretical values. To rectify this, it may be necessary to modify the pulley and belt setting. To this effect, the motors are fitted with variable pulleys.

SITE TEST AND MAINTENANCE

Measure the motor absorbed power.

If the absorbed power is greater and the pressure lower than the rated values, the ventilation system has a lower pressure drop than anticipated. Reduce the flow by reducing the rpm. If the system resistance is significantly lower than design, there is a risk that the motor will overheat resulting in an emergency cut out.

If the absorbed power is lower and the pressure greater than the rated values, your system has a higher pressure drop than anticipated. Increase the flow by increasing the rpm. At the same time you will increase the absorbed power which may result in having to increase the motor size.

To carry out the adjustment and to avoid a time-consuming re-start, stop the machine and if necessary lock the main switch. First unscrew the 4 Allen screw(s) on the pulley (see figure11).

Pulley type	Pulley External Diameter	Min Dia / Min Dist	Max Dia / Max Dist	Nb of turns from fully closed to fully open	Actual diameter (DM) or distance between faces for a given number of turns from fully closed with SPA belt in (mm)										
					0.5	1	1.5	2	2.5	3	3.5	4	4.5	5	5.5
8450 / D8450	120	95	116	5	114	112	110	108	106	103	101.3	99.2	97.1	95	-
		20.2	28	5	21	21.8	22.5	23.3	24.1	24.9	25.7	26.4	27.2	28	-
8550 / D8550	136	110	131	5	129	127	125	123	121	118	116	114	112	110	-
		20.6	31.2	5	21.6	22.7	23.8	24.8	25.9	26.9	28	29.1	30.1	31	-

Table_2

The easiest way to determine the fan rotation speed is to use a Tachometer. If not available the fan rpm can be estimated using the following two methods.

1st Method with the pulley secured in place:

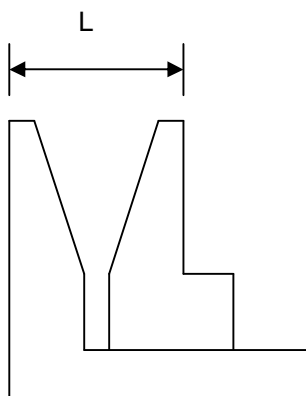

ALLEN wrench 4



Fig. 41

Measure the distance between the two outside faces of the pulley. Using **table (2)** the motor pulley actual diameter can be estimated

2nd method when adjusting the pulley :

- Close the pulley fully and count the number of turns from fully closed position. Using **table_2** determine the motor pulley actual diameter.
- Record the fix fan pulley diameter.(DF)
- Determine the fan speed using the following formulae:

$$\text{rpm}_{\text{FAN}} = \text{rpm}_{\text{MOTOR}} \times D_M / D_F$$

Where: rpm_{MOTOR} :from the motor plate or **table_3**
 D_M : from **table2**
 D_F: from machine

Once the pulleys are adjusted and the belt checked and tensioned, start the fan motor and record the Amps and Voltage between the phases :

Using the measured data and **table_3**

- Theoretical mechanical power at the fan shaft:

$$P_{\text{meca fan}} = P_{\text{meca Motor}} \times \eta_{\text{Transmission}}$$

$$P_{\text{meca fan}} = P_{\text{elec}} \times \eta_{\text{meca motor}} \times \eta_{\text{Transmission}}$$

$$P_{\text{meca fan}} = V \times I \times \sqrt{3} \times \cos\phi \times \eta_{\text{meca motor}} \times \eta_{\text{Transmission}}$$

This formula can be approximated in this way

$$P_{\text{meca fan}} = V \times I \times 1.73 \times 0.85 \times 0.76 \times 0.9$$

With the fan “rpm” and the mechanical power at the fan shaft an operating point and the supplied airflow can be estimated using the fan curves.

CHECKING AIRFLOW AND ESP

Using the fan curves on **page 25, 26, 27**, the airflow, the total pressure available (P_{TOT}) and the corresponding dynamic pressure (Pd) can now be estimated, for a specific operating point;

The next step consists in estimating the pressure losses across the unit.

This can be achieved using the “dirty filter pressure sensor” and the accessories pressure drop table: **table_4**
 Also the pressure drop due to the duct inlet into the roof-top unit can be taken as 20 to 30 Pa.

$$\Delta P_{\text{INT}} = \Delta P_{\text{filter + coil}} + \Delta P_{\text{Inlet}} + \Delta P_{\text{Options}}$$

using the results from above, the external static pressure (ESP) can then be estimated:

$$\text{ESP} = P_{\text{TOT}} - P_d - \Delta P_{\text{INT}}$$

Table_3 Motor information

Motor Size	Nom. Speed	Cos φ	η _{meca motor}
0.75 kW	1400 rpm	0.77	0.70
1.1kW	1429 rpm	0.84	0.77
1.5kW	1428 rpm	0.82	0.79
2.2kW	1436 rpm	0.81	0.81
3.0kW	1437 rpm	0.81	0.83
4kW	1438 rpm	0.83	0.84
5.5kW	1447 rpm	0.83	0.86
7.5kW	1451 rpm	0.82	0.87

**PERFORMANCES
ACCESSORIES PRESSURE DROPS**

BAC = Cooling only rooftop

BAH = Heat pump rooftop

BAG = Cooling only rooftop with gas fired heating

BAM = Heat pump rooftop with gas fired heating

Size	Airflow	Economiser	EU4 Filters	F7 Filters	Water Coil	Hot Electric heater (Pa)			Roofcurb	Multi directional	Heat Recovery module	
		(Pa)	(Pa)	(Pa)	(Pa)	S	M	H	(Pa)	(Pa)	Fresh	(1)
020	2900	18	0	39	31	57	58	60	16	23	108	69
	3600	28	6	66	46	105	107	109	24	35	161	105
	4300	39	12	98	61	146	149	151	35	50	226	151
030	3600	28	6	66	46	75	77	79	24	35	161	105
	4500	43	14	108	66	133	135	138	38	55	247	165
	5400	62	25	160	89	187	190	193	55	79	352	238
035	5000	22	5	62	51	75	78	81	25	24	149	105
	6300	36	14	104	76	134	138	141	39	38	230	167
	7600	52	24	155	105	189	193	197	58	56	331	243
045	6500	23	3	52	56	81	85	89	20	29	113	80
	8100	36	10	86	82	141	145	150	32	45	170	124
	9700	51	18	127	113	196	201	207	46	64	239	177
055	7200	28	6	66	67	94	98	102	25	35	136	98
	9000	44	14	108	99	160	165	170	39	55	207	153
	10800	63	25	160	136	224	230	236	56	80	293	220
065	8600	16	3	50	58	62	67	72	19	12	129	91
	11500	29	12	96	90	112	119	125	33	37	223	162
	13000	37	18	125	119	152	159	167	43	26	282	207
075	9 950	22	7	70	75	74	79	85	25	16	171	123
	13500	35	16	117	113	128	135	142	40	25	204	223
	14000	56	31	194	172	186	195	204	65	40	326	240

EXAMPLE

The unit used for this example is a BAH035NSM1M with Economiser and Electric Heater type H
It is fitted with a fan which curve is shown on **page 26** and a 2.2kW motor.

- Motor rpm: 1430 rpm
- $\cos\phi = 0.81$
- Voltage = 400V
- Current = 3.77A

$$P_{\text{mech fan}} = V \times I \times \sqrt{3} \times \cos\phi \times \eta_{\text{mech motor}} \times \eta_{\text{Transmission}}$$

$$= 400 \times 3.77 \times \sqrt{3} \times 0.81 \times 0.76 \times 0.9 = \underline{1.45\text{kW}}$$

The unit is also fitted with a transmission kit 7

- Fixed Fan pulley: 160mm
- Motor adjustable pulley type "8450" opened 4 turns from fully closed or measured distance between pulley end plates is 25.7mm: from **table 2** it can be determined that the motor pulley has a diameter of **99.2mm**

$$\text{rpm}_{\text{FAN}} = \text{rpm}_{\text{MOTOR}} \times D_M / D_F = 1430 \times 99.2 / 160 = \underline{886.6 \text{ rpm}}$$

Using the fan curve below the operating point can be located.

It can be determined that the fan is providing approximately **6300 m³/h** with a total pressure $P_{\text{TOT}} = \underline{530 \text{ Pa}}$

Fig. 42

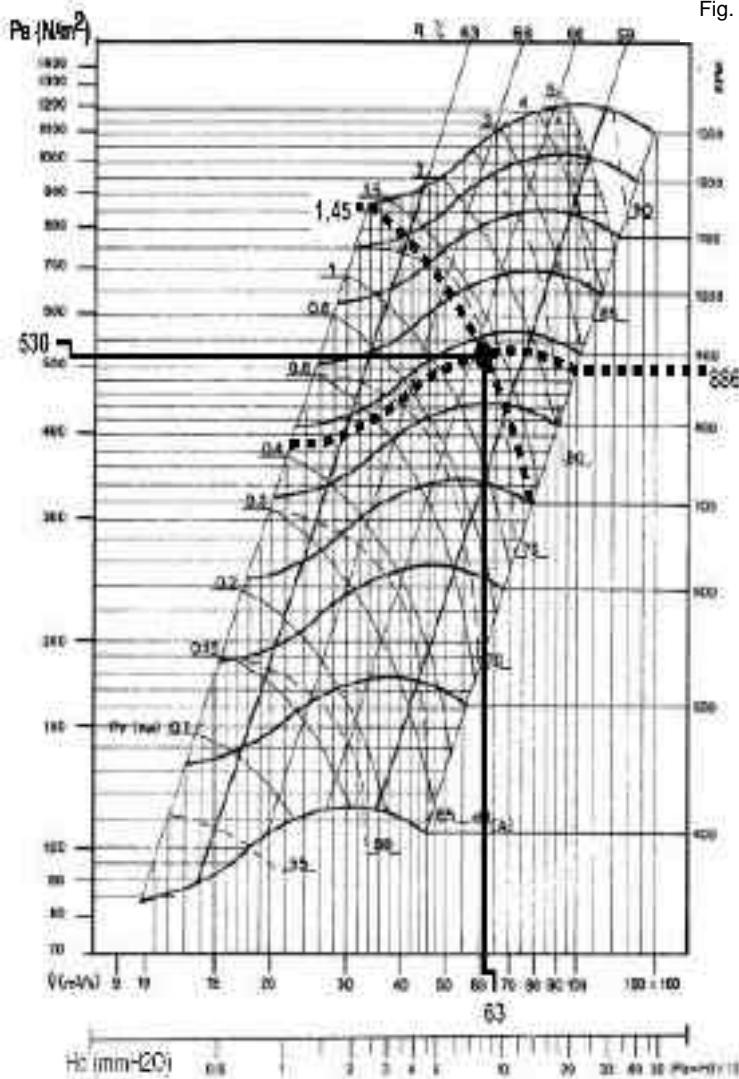

The pressure losses in the unit are the sum of all pressure drops across the different parts of a unit:

- Coil and filter (measured) = 104 Pa
- Inlet into the unit = 30 Pa
- Options = 23 Pa for economiser and 91 Pa for electric heater H

$$\Delta P = 104 + 30 + 23 + 91 = \underline{248 \text{ Pa}}$$

The dynamic pressure at 7200m³/h is given at the bottom of the fan curve (page 26).

$$P_d = \underline{81\text{Pa}}$$

The external static pressure available is therefore

$$\text{ESP} = P_{\text{TOT}} - P_d - \Delta P_{\text{INT}} = 580 - 110 - 248 = \underline{201 \text{ Pa}}$$

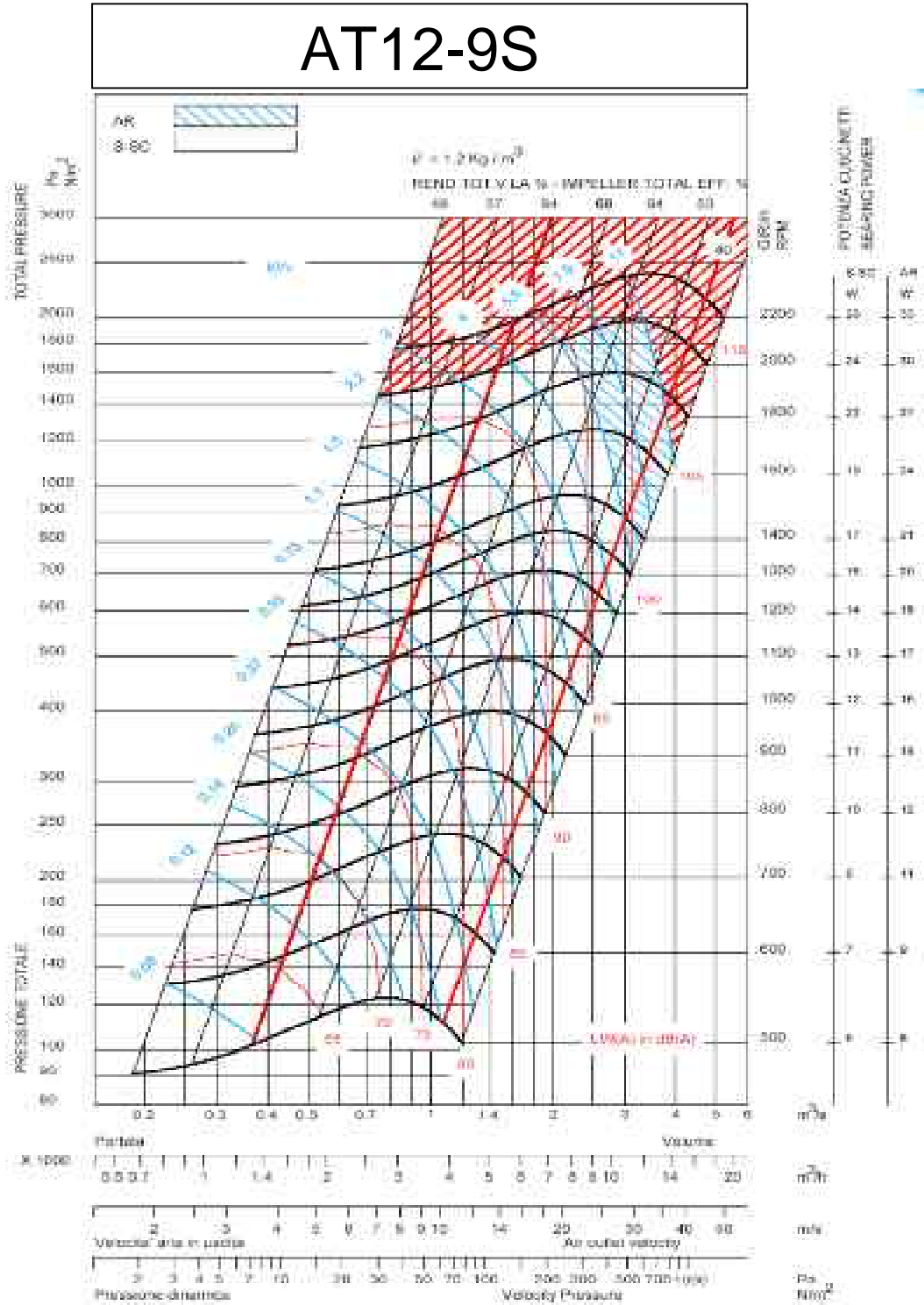

AT15-11S

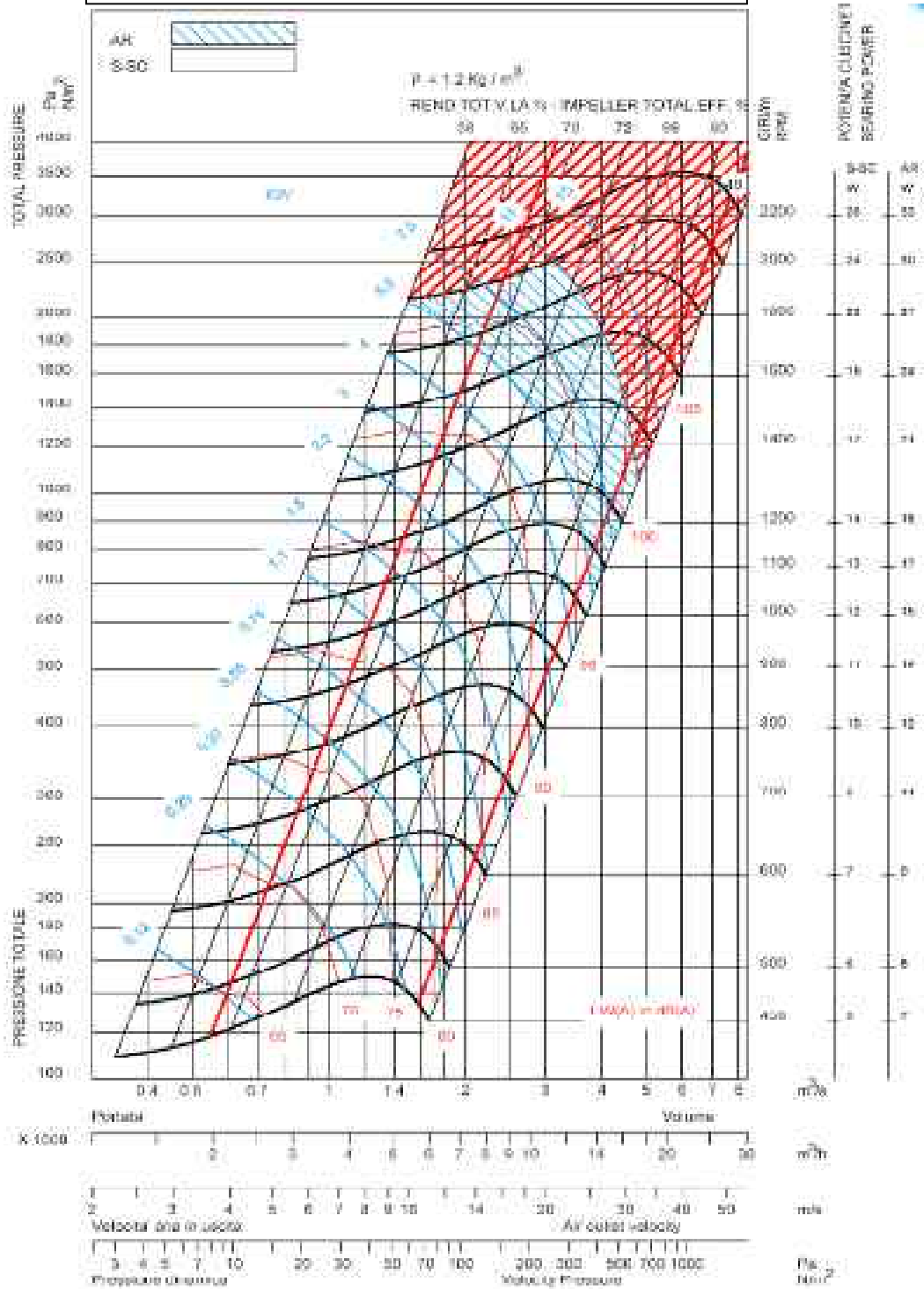

AT15-15S

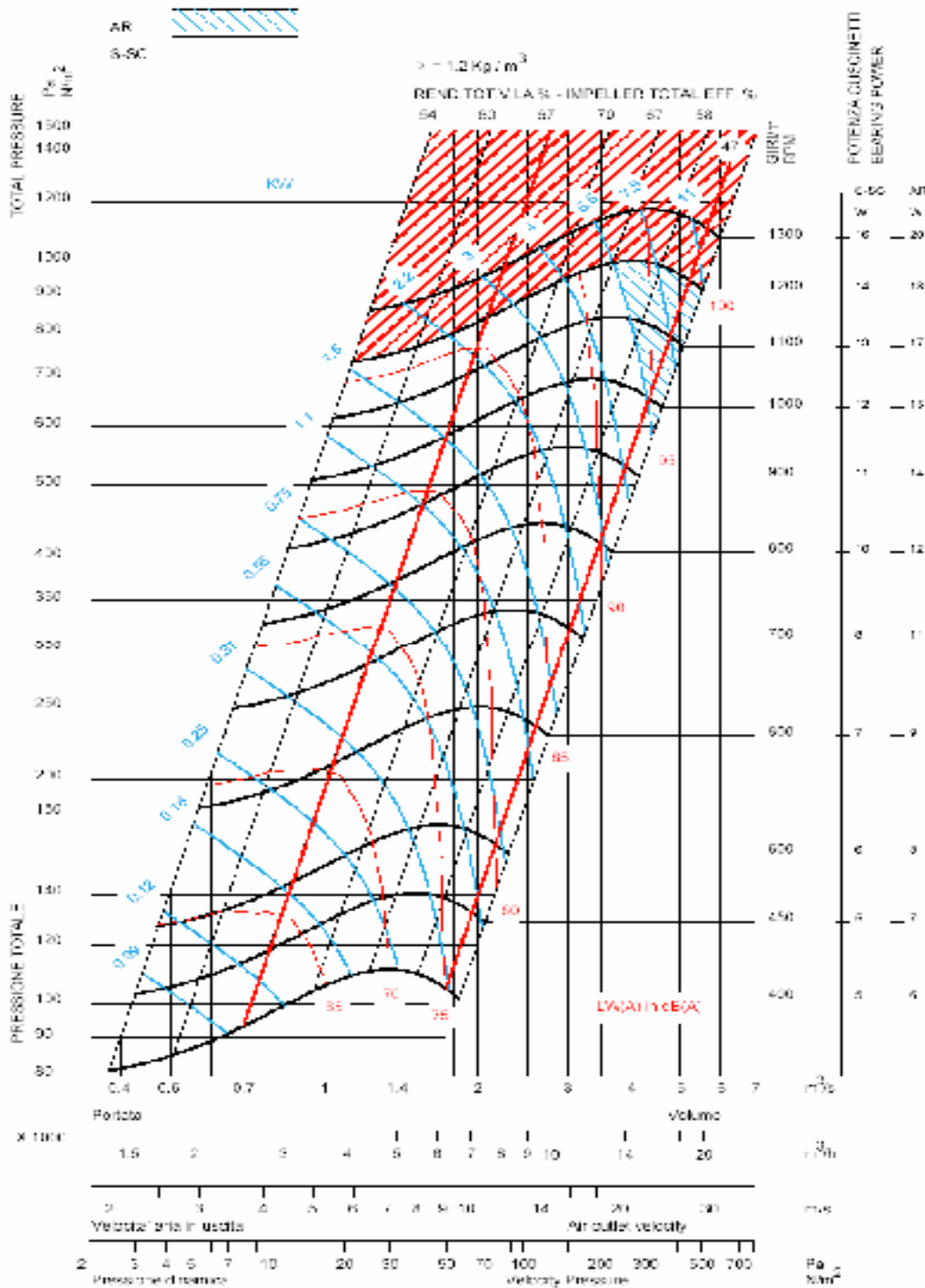

ROOF TOP & EXHAUST ROOF CURB

065 075

AT15-11G2L

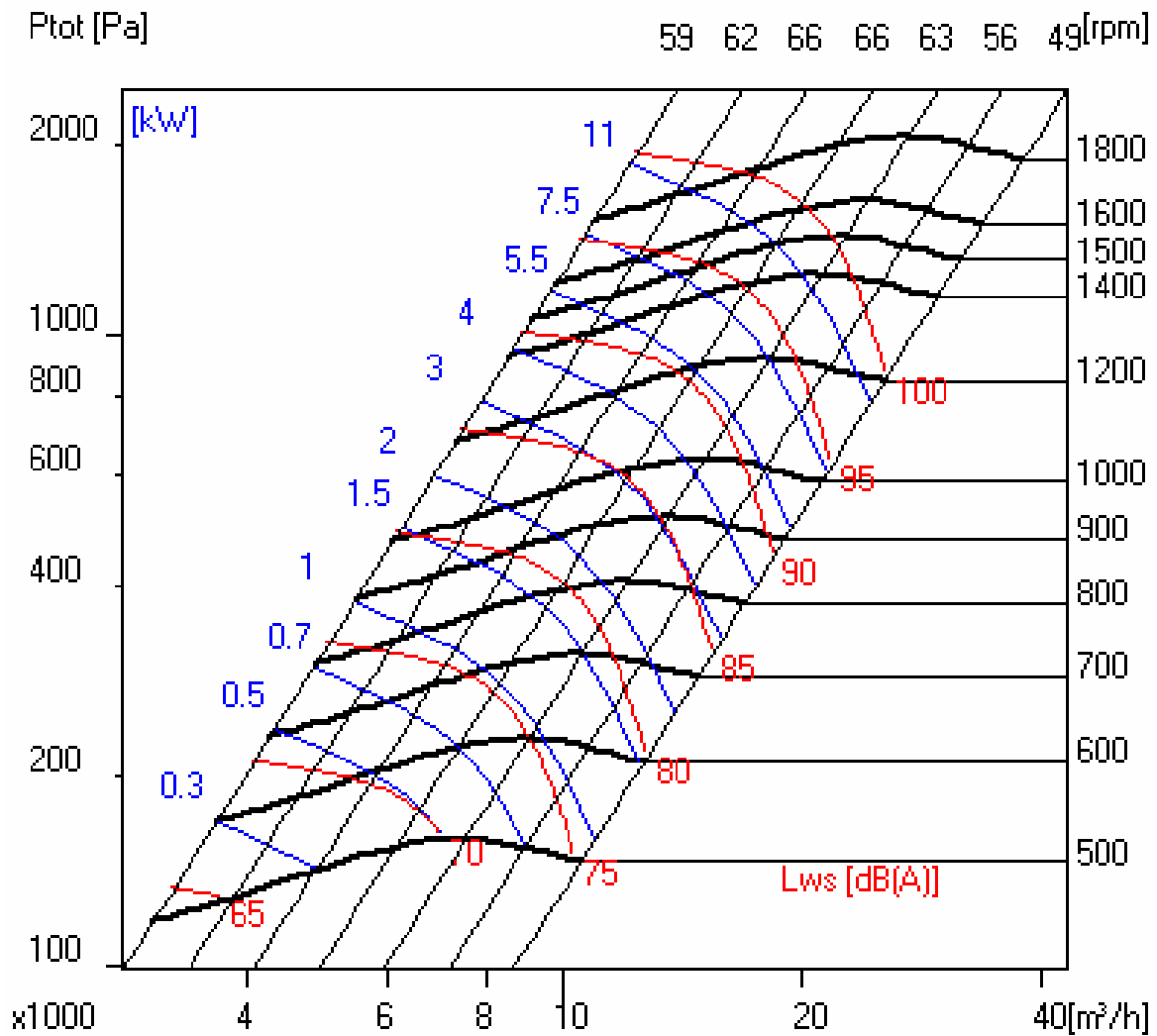

EXHAUST ROOF CURB

020

030

AT10-10S

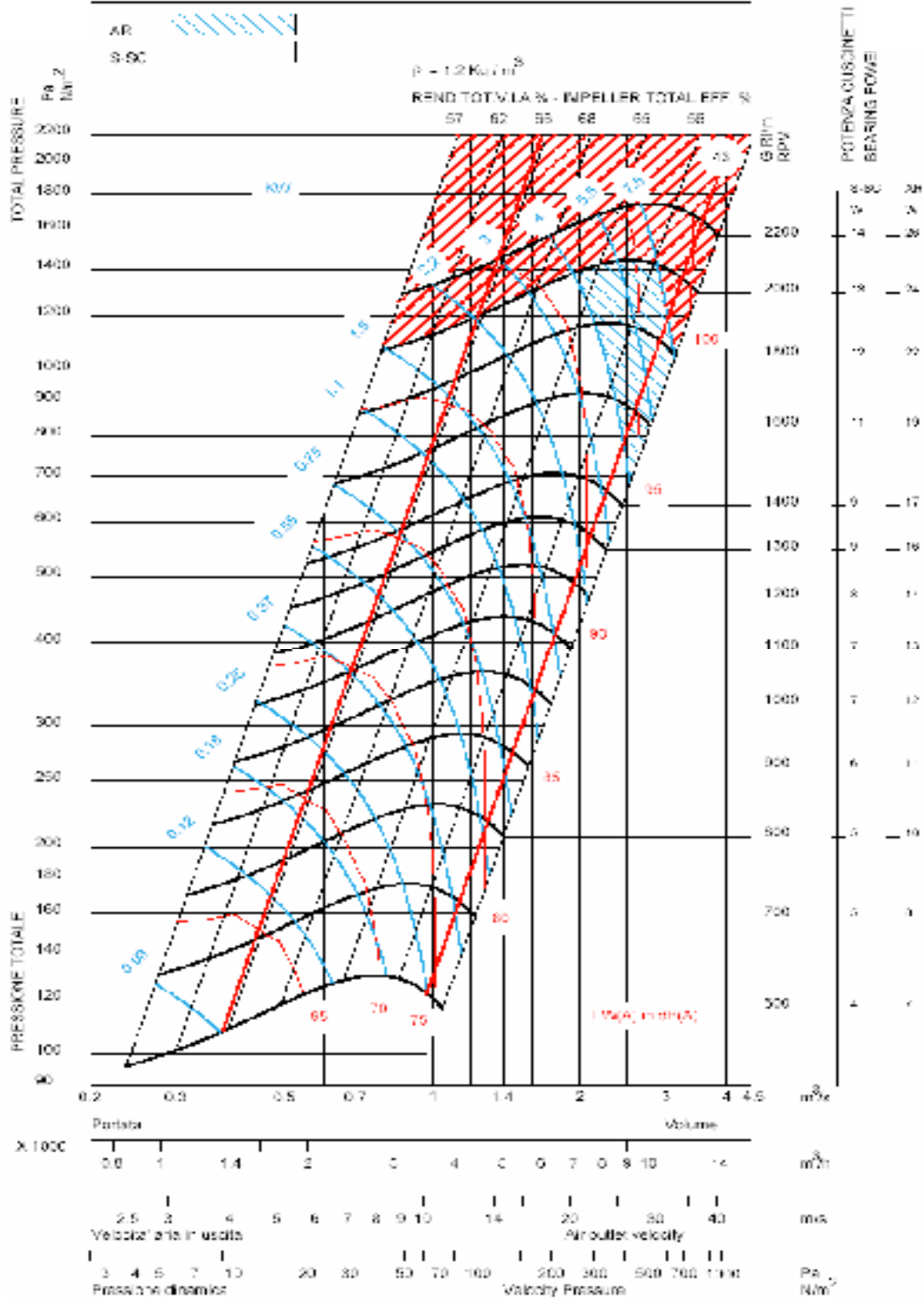

EXHAUST ROOF CURB **045** **055**

AT10-10G2L

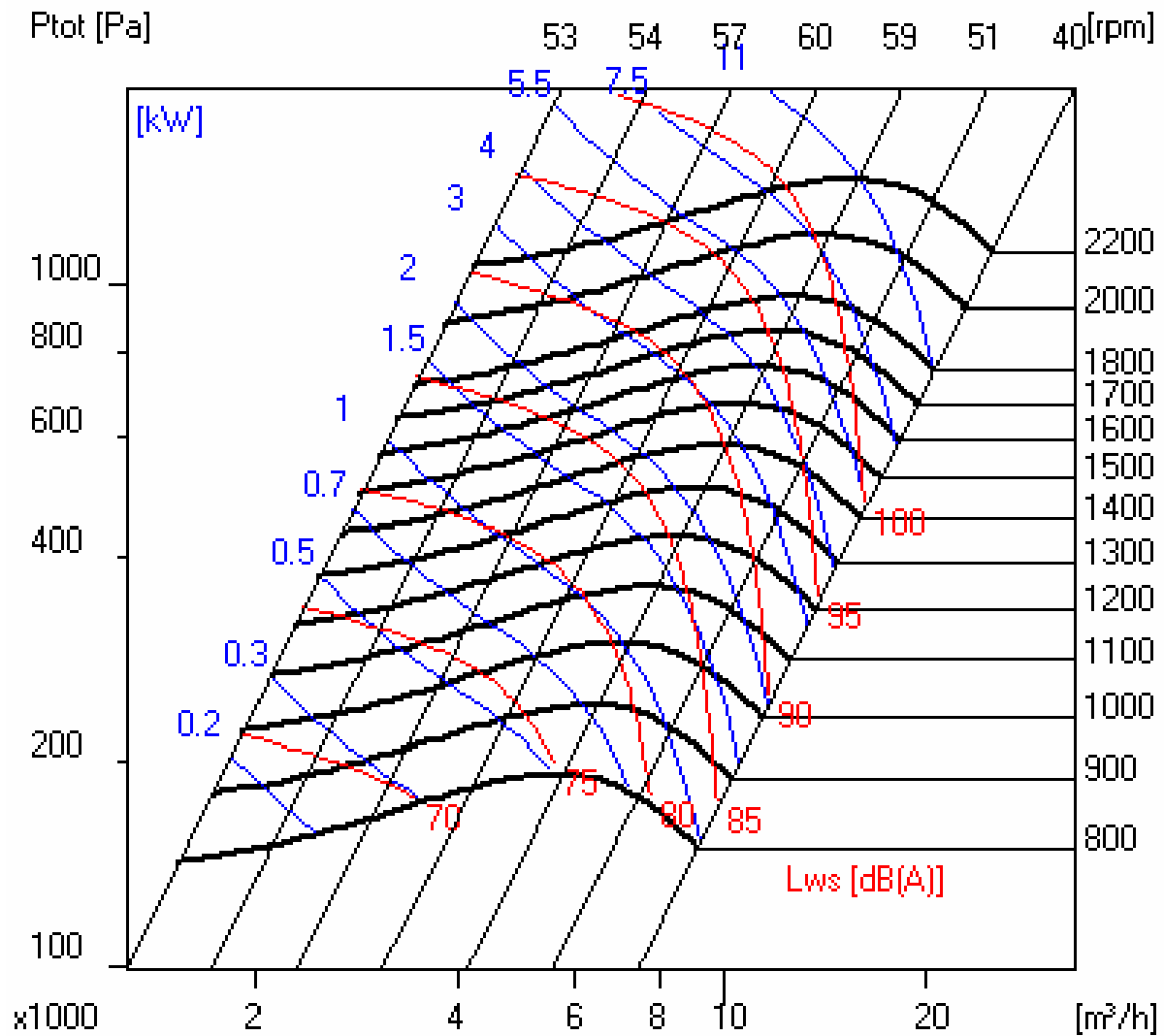

FILTER REPLACEMENT

After opening the filter access panel, lift the filter retaining log.
The filters can then be removed and replaced easily by sliding the dirty filters out and clean ones in.



Fig. 43

The CLIMATIC controller can monitor the pressure drop across the filter (If option fitted)

The following set points can be adjusted depending on the installation.

“Airflow”	in page 3411 = 25Pa by default
“No filter “	in page 3412 = 50Pa by default
“Dirty Filter”	in page 3413 = 250Pa by default

The actual pressure drop measured across the coil can be read on the Climatic Display DS50 in menu **2131**.

The following faults may be identified

- -Fault code **0001** AIRFLOW FAILURE, if measured ΔP across the filter and coil is below the value set in page **3411**
- -Fault code **0004** DIRTY FILTERS, if measured ΔP across the filter and coil is above the value set in page **3413**
- -Fault code **0005** MISSING FILTERS, if measured ΔP across the filter and coil is below the value set in page **3412**

AIR SOCK CONTROL



Menu

- Press the Button "Mode" to enter and exit menus
- The Vertical arrows allow to seek each options
- The "Enter" button allow to select a menu or a parameter to modify it, it also allows to validate it once modified

Quick Setting

- Press the mode button and enter the quick menu "AUF"
- Modify and check the "AUF" sub-menus
 - o AU1 "automatic acceleration/deceleration" must be set to ZERO
 - o Acc "acceleration" : set to 50 s
 - o Dec "deceleration" : set to 30 s
 - o LL "low speed" : set to 0Hz
 - o UL "high speed" : set to 50Hz
 - o tHr "motor thermal current" : adjust this setpoint equal to nominal motor amps
 - o uL "motor nominal frequency" : set to 50Hz
 - o uLu "nominal motor voltage" : set to 400V

If those parameters are unseen, check that the "loc rem" button located in front is lighting because this allows a remote parameter control. Push this button to get the control back into the display

HYDRAULIC CONNECTIONS

The hot water coil is fitted with a three way proportional valve and two isolating shut off valves. Two spanners must be used to tighten the connections. One spanner must maintain the valve body when connecting the pipe-work to the main. Failure to do so may damage the pipes joints and invalidates the warranty.

Filling up and starting the system

- Adjust the control for Heating by reducing the simulated ambient temperature down to 10°C
- Check that the red indicators located under the valve actuator are moving correctly with the signal.

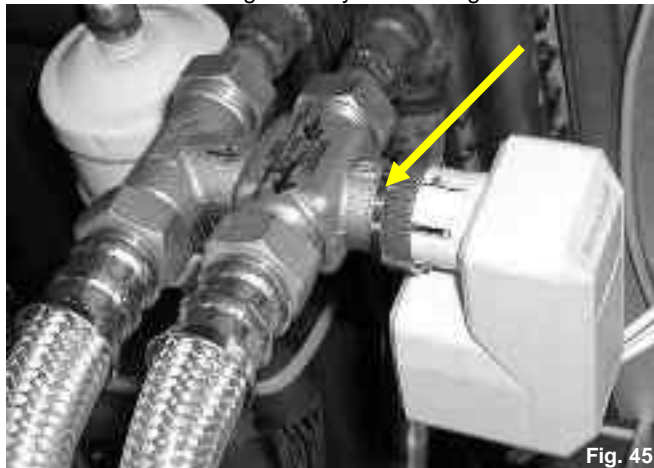

- Fill the hydraulic system and bleed the coil using the air vents. Check incoming hot water.
- Check the various connections for possible leaks

FREEZE PROTECTION

- 1) Glycol for freeze protection.

Check the hydraulic system contains Glycol for protection against freezing.

GLYCOL IS THE ONLY EFFECTIVE PROTECTION AGAINST FREEZING

The antifreeze must protect the unit and avoid icing under winter conditions.

WARNING: Mono-ethylene glycol based fluids may produce corrosive agents when mixed with air.

- 2) Drain the installation.

You must ensure that the manual or automatic air bleeders have been installed on all high points in the system. In order to drain the system, check that all the drain cocks have been installed on all low points of the system.

HEATING HOT WATER COILS FROZEN DUE TO LOW AMBIENT CONDITIONS ARE NOT COVERED BY THE WARRANTY.

ELECTROLYTIC CORROSION

Attention is drawn to the corrosion problems resulting from electrolytic reaction created by unbalanced earth connections.

ANY COIL DAMMAGED BY ELECTROLYTIC CORROSION IS NOT COVERED BY THE WARRANTY

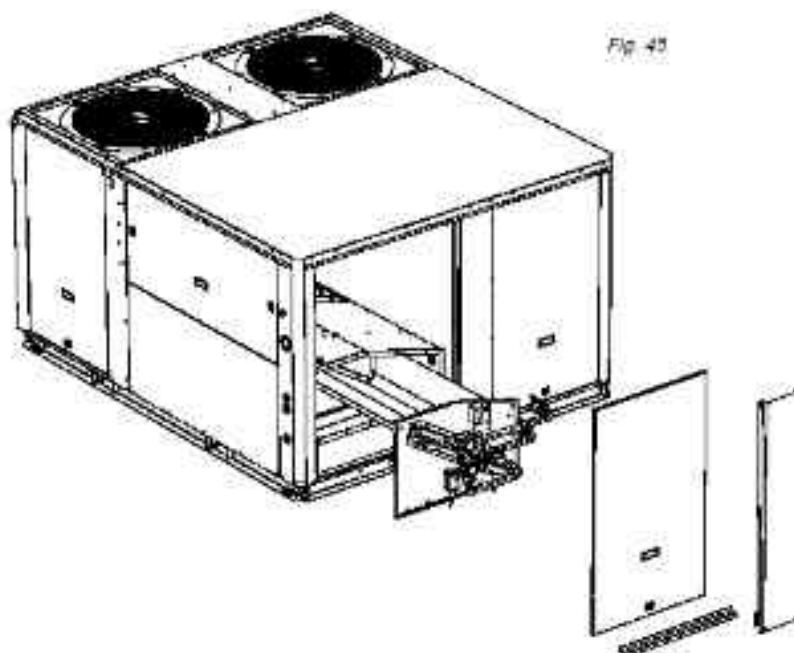

Connection HWC B box

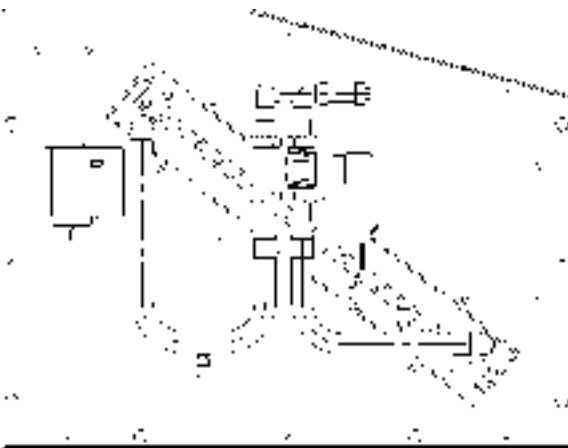

Connection HWC C box

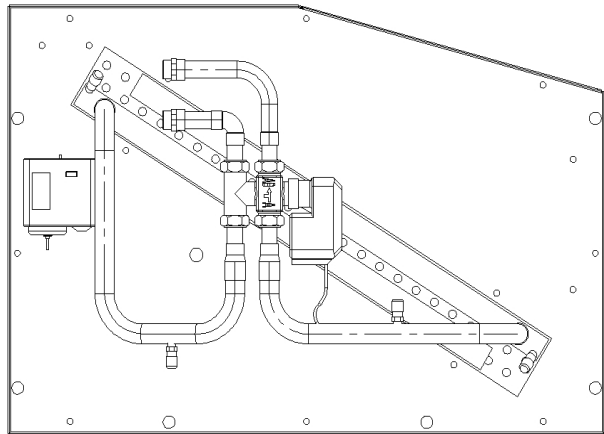

Connection HWC D box

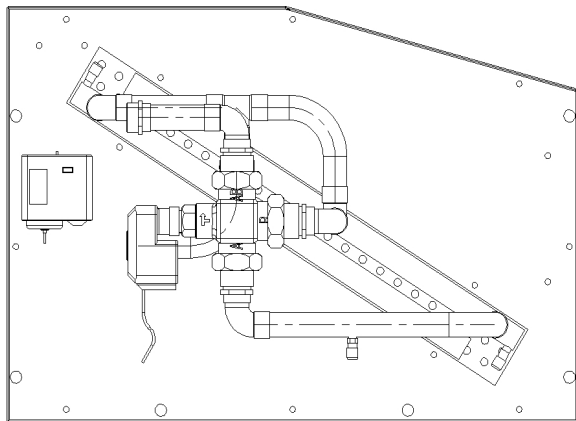

Connection HWC E box

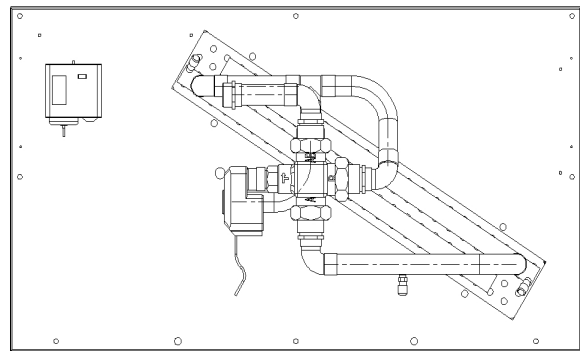

Fig. 46

Pipe Internal Diameters (DN)

	B020	B030	B035	B045	B055	B065	B075
H	20	20	20	25	25	25	25

MAXIMUM WORKING PRESSURE: 8 BARS
MAXIMUM WORKING TEMPERATURE: 110°C

GENERAL INFORMATION

The Baltic electric heaters are stand alone options which are fitted in the heating section of the unit. As for the hot water coil or the gas burner this option slides into the heating compartment located under the supply fan.

In order to reduce the pressure drops the airflow is ducted around the shielded resistances. The resistances are made smooth stainless steel tubes with a capacity of 6W/cm².

It is protected as standard, against overheat via a high temperature overload protection set at 90°C and located less than 150mm after the heater itself.

There are three sizes available for each size of unit:

S: Standard heat

M: Medium heat

H: High heat

The standard and Medium heat electric heaters are staged control with 50% or 100%. The high heat versions is controlled through a fully modulating triac.

Module size	380V		400V		415V	
	Current	Capacity	Current	Capacity	Current	Capacity
(kW)	(A)	(kW)	(A)	(kW)	(A)	(kW)
12	16,3	10,8	17,0	11,8	17,8	12,8
24	32,6	21,5	34,0	23,5	35,6	25,6
27	36,7	24,3	38,3	26,6	40,1	28,8
36	48,9	32,3	51,1	35,3	53,3	38,4
45	61,1	40,5	63,8	44,3	66,8	48,0
48	65,2	43,0	68,1	47,0	71,1	51,3
54	73,4	48,4	76,6	52,9	80,0	57,7

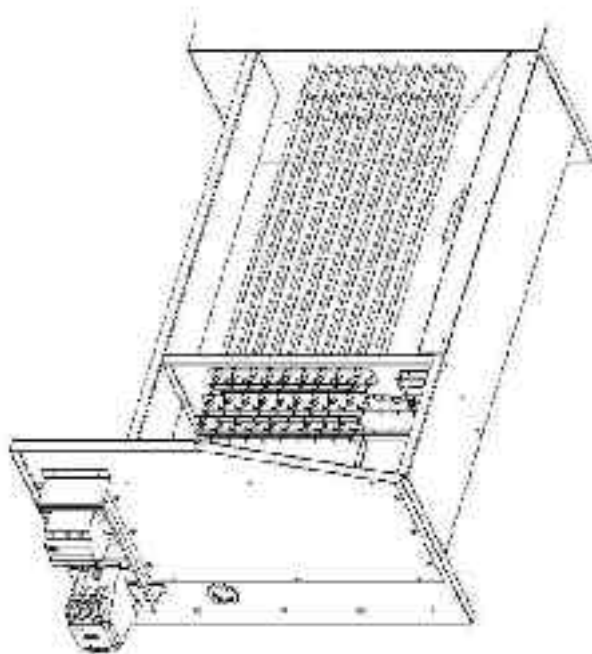

Fig. 47

PRELIMINARY CHECKS BEFORE START-UP

NOTE :

ANY WORK ON THE GAZ SYSTEM MUST BE CARRIED OUT BY QUALIFIED PERSONNEL.

THIS UNIT MUST BE INSTALLED IN ACCORDANCE WITH LOCAL SAFETY CODES AND REGULATIONS AND CAN ONLY BE USED IN PLANED INSTALLATION CONDITIONS FOR OUTDOOR.

PLEASE READ CAREFULLY THE MANUFACTURER'S INSTRUCTIONS BEFORE STARTING A UNIT.

BEFORE COMMISSIONING A UNIT WITH GAZ BURNER, IT IS MANDATORY TO ENSURE THAT THE GAZ DISTRIBUTION SYSTEM (type of gas, available pressure...) IS COMPATIBLE WITH THE ADJUSTMENT AND SETTINGS OF THE UNIT.

Check access and clearance around the unit

- Make sure one can move freely around the unit.
- A minimum one-meter clearance must be left in front of the burnt gas exhaust flue.
- Combustion air inlet and burnt gas exhaust(s) must NOT be obstructed in any way.

Supply Network Pipe Sizing

MALE THREADED CONNECTION FOR GAZ BURNER: 3/4"

Check that the gas supply line can provide the burners with the pressure and the gas flow rate necessary to provide the heating nominal output.

Number of male threaded connections (3/4")

UNIT SIZE	20	25	35	45	55	65	75
S POWER	1	1	1	1	1	1	1
H POWER	1	1	1	1	1	2	2

GAS FLOW (for G20 at 20mbar and 15°C) m³/h

UNIT SIZE	20	30	35	45	55	65	75
S POWER	2	2	2	3	3	5.7	5.7
H POWER	3	3	5	6	6	11.5	11.5

For modulating gas we have just H power for C, D & E-box

- The gas supply of a Rooftop gas unit must be realized according to Sound Engineering Practice and the local safety codes and rules.
- In any case the diameter of pipe-work connected to each Rooftop must not be smaller than the diameter of the connection on the Rooftop unit.
- Make sure that a shut-off isolation valve has been installed before EACH Rooftop.
- Check the supply voltage to the exit of the power supply's transformer T3 of the burner: it must be between 220 and 240V.

STARTING UP THE GAS BURNER

Fig. 48



Purge the pipe-work near the connection on the ignition control Valve for a few seconds.

- Check that the unit's treatment "Fan" blower is running.
- Set the control to "ON" This will priorities the gas burner.
- Increase the set temperature (room set point temperature) to a temperature higher than the actual room temperature.

PRESSURE ADJUSTMENTS ON HONEYWELL PRESSURE REGULATING VALVE TYPE VK 4105 G

Pressure regulator adjustment with 300mbar gas supply:



Fig. 49

- The Burner must run in High Heat mode for this check.
- Place the tube of the “accurate” manometer on the **Inlet** pressure port (**Figure 50**) of the Gas Regulating Valve after having loosened the screw by one turn

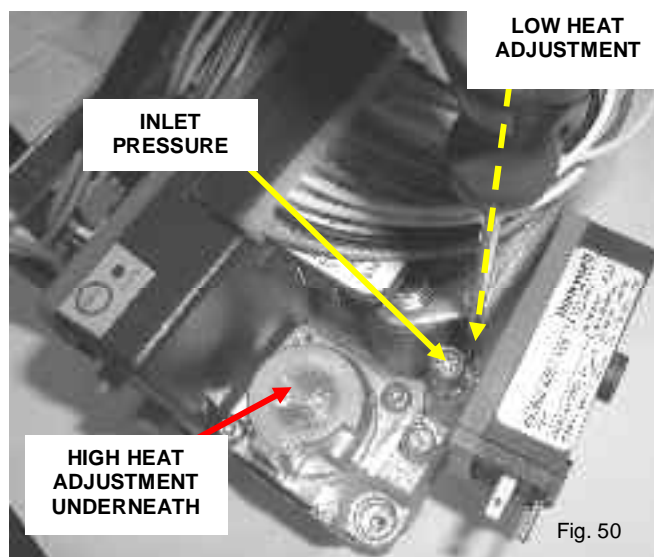

Fig. 50

- Check and adjust if necessary the valve **Inlet** pressure to 20.0mbar (G20) or 25.0mbar for Groningue (G25) or 37.0mbar for propane (G31). after gas burner ignition (fig.51)

Fig.51



High Heat Injection Pressure Checks

- Place the tube of the “accurate” Manometer to the **OUT** port on the Gas injector support bar after having loosened the screw by one turn.



Check and adjust if necessary the valve **OUTLET** pressure to 8.4mbar (G 20) / 12.3mbar for Groningue (G25) & 31.4 mbar for propane (G31) (fig.53)

Fig. 53



Low Heat Injection Pressure Checks

- Switch the control to Low Heat
- Check and adjust if necessary the **Outlet** pressure to 3.5 mbar (G20) or 5 mbar for Groningue(G25) & 14 mbar for propane (G31)(fig.54)

Fig. 54



Valve electrical control

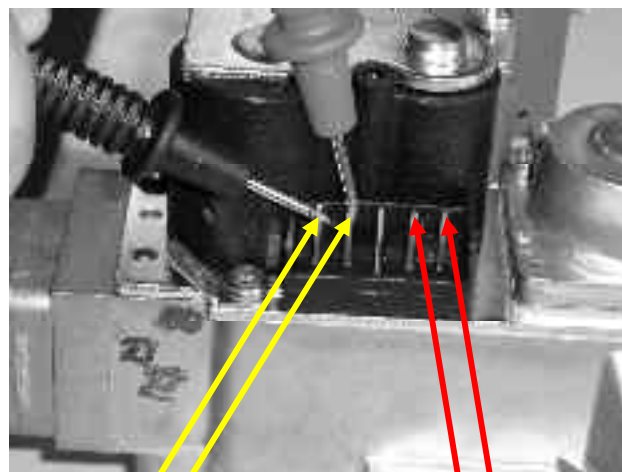

Fig. 56

- Check these values with an ohmmeter.

Fig. 55



- After the adjustment of the low heat, re-verify the high heat
- re-position the stoppers and close the pressure ports.

Pressure adjustments table for each type of gas (mbar)

Category	Supply pressure	Low Heat Injection min.	High Heat Injection
G20	20.0 +/- 1	3.5 +/- 0.1	8.4 +/- 0.2
G25 (Groningue)	25.0 +/- 1.3	5.0 +/- 0.1	12.3 +/- 0.2
G31 (GPL)	37.0 +/- 1.9	14.0 +/- 0.3	31.4 +/- 0.6

BURNER SAFETY CHECKS

Smoke extractor pressure switch Test.

- With the gas burner running, disconnect the flexible tube fitted to the pressure tapping on the pressure switch (Fig. 57).
- The Flame must disappear and the extraction fan must carry on running.
- However, NO fault will be displayed (Gas ignition control block or CLIMATIC).

Fig. 57



- After reconnecting of the tube, the Burner will restart after a period of 30 to 45 seconds pre-ventilation.

Gas pressure switch test

- With the gas burner running, close the shut off valve located before the rooftop. (fig. 58)

Fig. 58



- The burner stops completely.
- However, No fault light will be displayed on the Gas ignition control block. After 6 Minutes, the CLIMATIC will display a fault.
- Reset the CLIMATIC.

Ionisation Probe test

- With the gas burner running, disconnect the terminal plug coming from the ionisation probe to the gas ignition control box.

Fig. 59



- The flame disappears
- The fan is still running and attempting to restart the burner (restart cycle 30 to 45 seconds).
- if the ignition probe is not reconnected at the end of the ignition sequence the burner will stop completely.
- The fault light on the gas ignition control block is ON.
- Manually reset the gas ignition control block to eliminate the fault

IN CASE OF PROBLEMS REFER TO THE START UP SEQUENCE FLOWCHART NEXT PAGE

GAS BURNER FIRE-UP SEQUENCE

Fig. 60

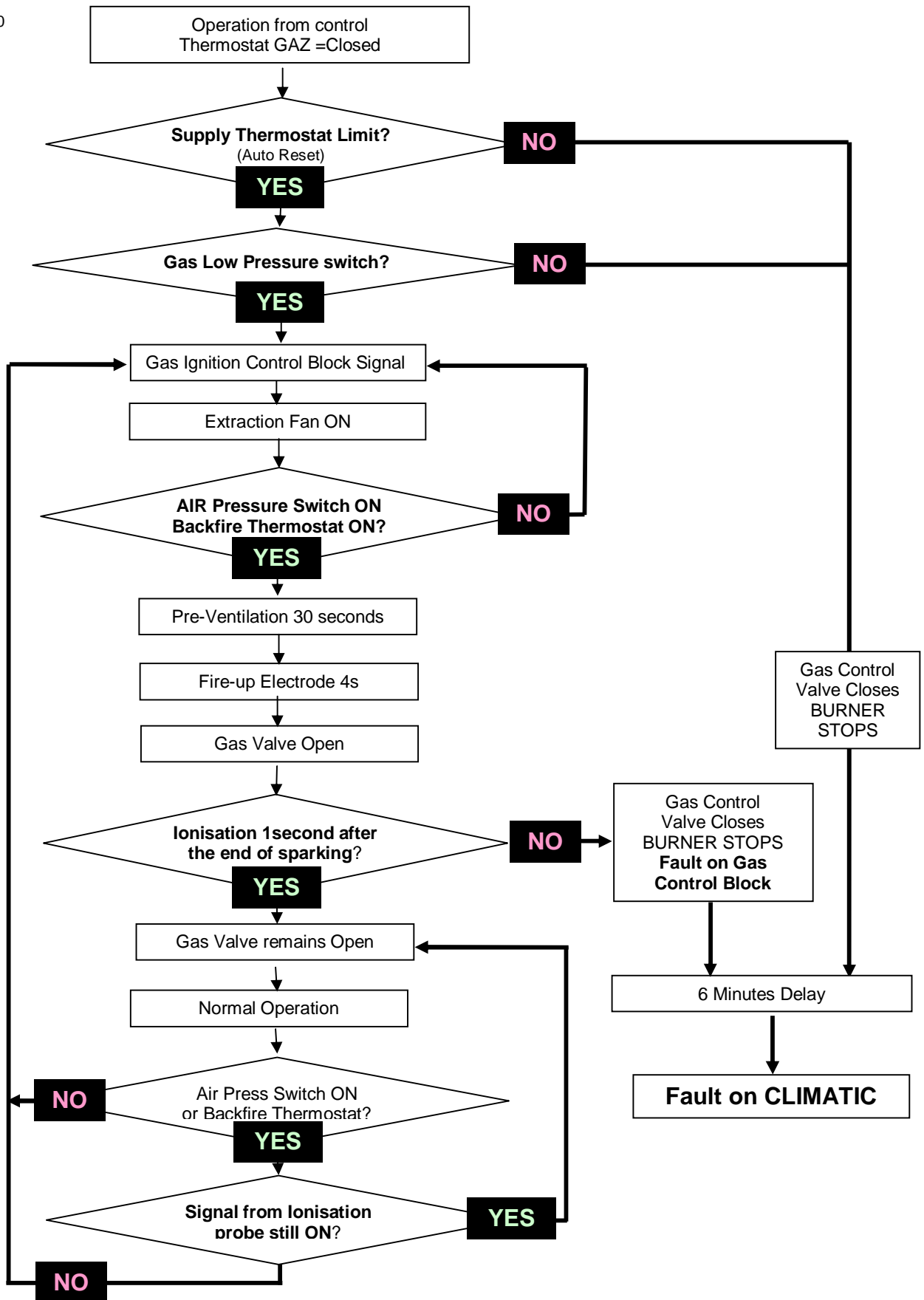

GAS BURNER TROUBLESHOOTING

If faults reported on CLIMATIC

- Reset the CLIMATIC.
- Check voltage: 230V after circuit breaker.
- Check GAS isolation shut-off valves are open.
- Check GAS pressure at the inlet of the GAS valves. It must be >20 mbar when the Burners shut down.
- Adjust the set points to priorities the burner. Increase the value of the room temperature set point to a temperature higher than actual room temperature.

DIAGNOSTIC TABLE BALTIC GAS BURNER				
STAGE	NORMAL OPERATION	POSSIBLE FAULT	ACTION	POSSIBLE SOLUTION
Heating Requested	Green, yellow & red L.E.D. ON	All L.E.D. OFF → fault on the blower thermostat	+ Check connections on the blower thermostat.	+ Replace thermostat
		Yellow & red L.E.D. OFF → lack of gas supply	+ Check valve's opening & supply pressure	+ Restore gas supply
		Red L.E.D. OFF → fault on the superheat thermostat on the gas burner support bar	+ Check thermostat's operation after manual reset	+ Replace thermostat
L.E.D ON	Extraction Fans are running	After 10 seconds safety shutdown by the ignition control block	+ Check connections of the control block on the gas valve + Check impedance of electro valve's coils: (1) = 2.90kΩ; (2) = 1.69kΩ (fig. n° 80, p 75)	+ Repositioning of the control block on the valve + Replace valve
		Nothing happens	+ Check the free movement of the fan wheel + Check Electrical connection on the Gas Ignition Control Block and on EF connection Board + Check the Fan supply voltage	+ Replace fan + Replace EF connection board If necessary
Extraction Fan is ON	After 30 to 45 seconds: pre-ventilation the fire-up electrode should spark.	Continuous Ventilation without sparks from fire-up electrode	+ Check the fire-up electrode + Check the pressure drop at the pressure switch: It must be higher than 165 Pa +Check the good operation of the pressure switch using an Ohmmeter and by artificially creating a depression in the tube.	+ Re-position the pressure switch tube. + Change the pressure switch.
Continuous ventilation and sparks from fire up electrode.	After a few seconds the gas burner fires-up	After 4 seconds the GAS Burner still not operating and safety shutdown by the Ignition Control Block.	+ Check injection pressure during start-up (Value for High Heat) +Remove the control box from the gas block.	+ Remove the air from the Gas pipe-work + Adjust the injection pressure to high heat value. + Change the Control Box if the Gas valve is OK.
		Within 4 seconds the gas Burner fires-up BUT safety shutdown from the Ignition Control Block.	+ Check the Position and connection of the Ionisation Probe. It must not be Earthed (230V). + Check that R.C circuit of the gas burner's transformer is well connected to the neutral polarity + Measure the Ionisation Current: It must be higher than 1.5 microAmps. + Check the Type of GAS.	+Check the whole electrical supply. + Adjust the supply and injection pressure if gas is different from natural gas G20 :(G25 Gas of Groningue for example).

DISASSEMBLING THE GAS BURNER FOR MAINTENANCE PURPOSES

Preliminary Safety Recommendations

- Isolate the unit using the main isolator switch.
- Close off the isolating gas valve located before the unit.
- Disconnect the Pipe-work. Do not discard the seals.



Fig. 61

Disassembling the gas «burner support bar»

- Disconnect the Electrical Connector on the electric connection board EF47
- Remove the two screws which hold the gas Bar in Place
- Carefully remove the gas « burner support bar » avoiding any damages to the electrodes.

Fig. 62



Fig. 63



Disassembling the flue

- Electrically disconnect the fan and remove the screws holding it in place.
- Take care not to loose any cage nuts in the smoke box.

ATTENTION: Check the correct position of the pressure tube used by the extraction pressure switch.

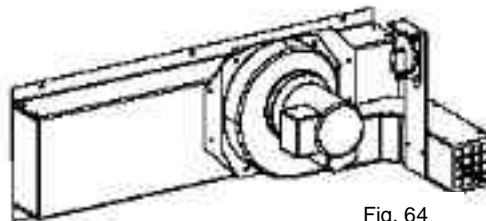

Fig. 64

Required Equipment List for maintenance Adjustment and Start-up

- An accurate manometer from 0 to 3500 Pa (0 to 350 mbar): 0.1% full scale.
- A Multimeter with Ohmmeter and Micro-amps scale
- An Adjustable Spanner
- Tube Spanner Set: 8, 9, 10, and 13.
- Flat Screwdrivers diameter 3 and 4, Phillips n°1
- Vacuum cleaner
- Paint brush

Fig. 65



GAS BURNER SUPPORT BAR

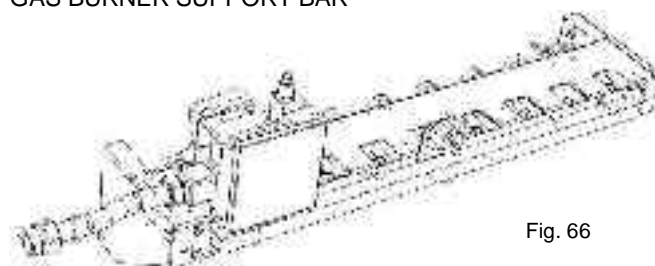

Fig. 66

MODULE-GAZ-20KW-B-BOX

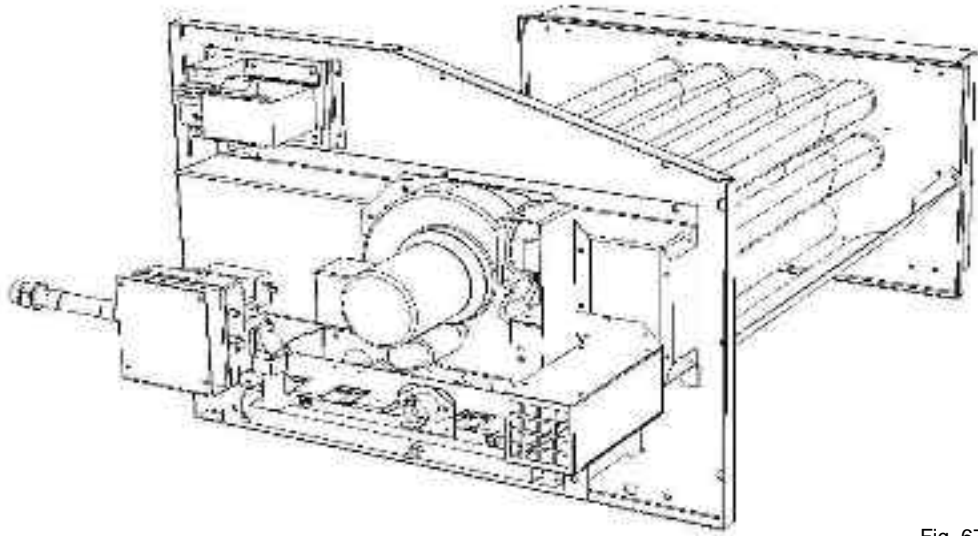

Fig. 67

MODULE-GAZ-33KW-B-BOX

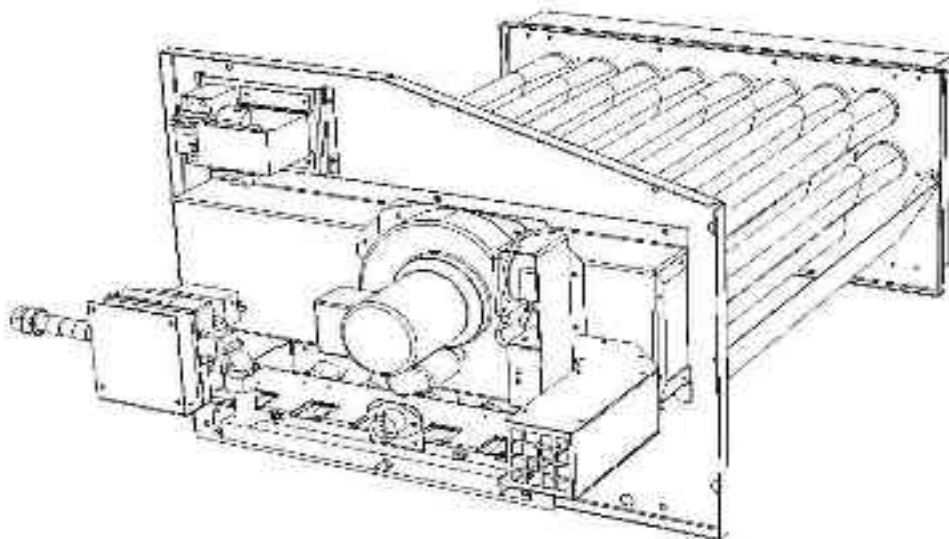

Fig. 68

MODULE-GAZ-20KW-C-BOX

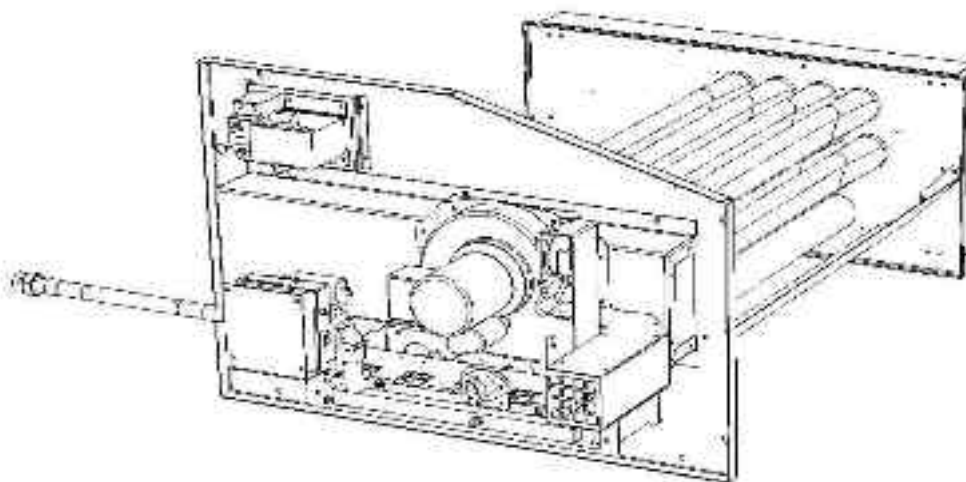

Fig. 69

MODULE-GAZ-46KW-C-BOX

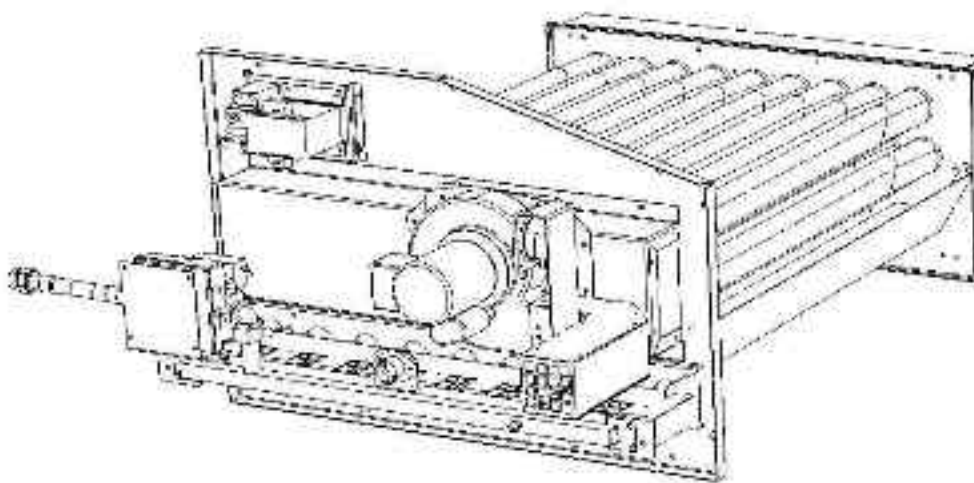

Fig. 70

MODULE-GAZ-33KW-D-BOX

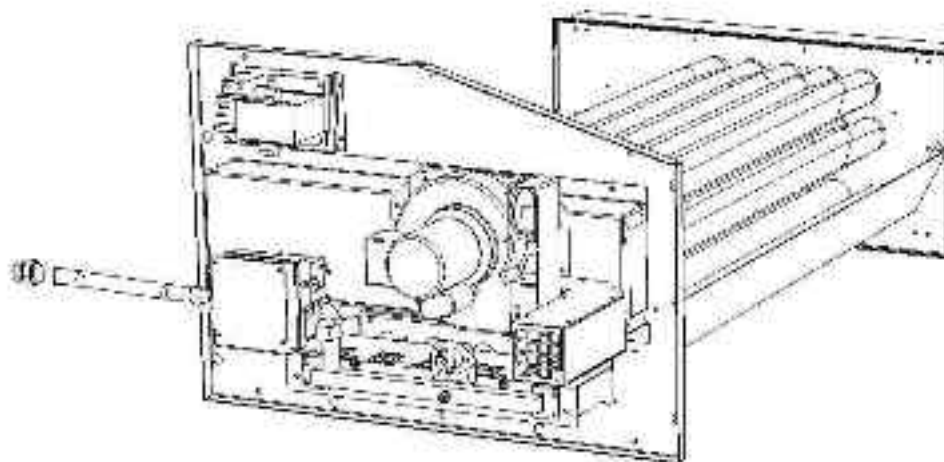

Fig. 71

MODULE-GAZ-60KW-D-BOX

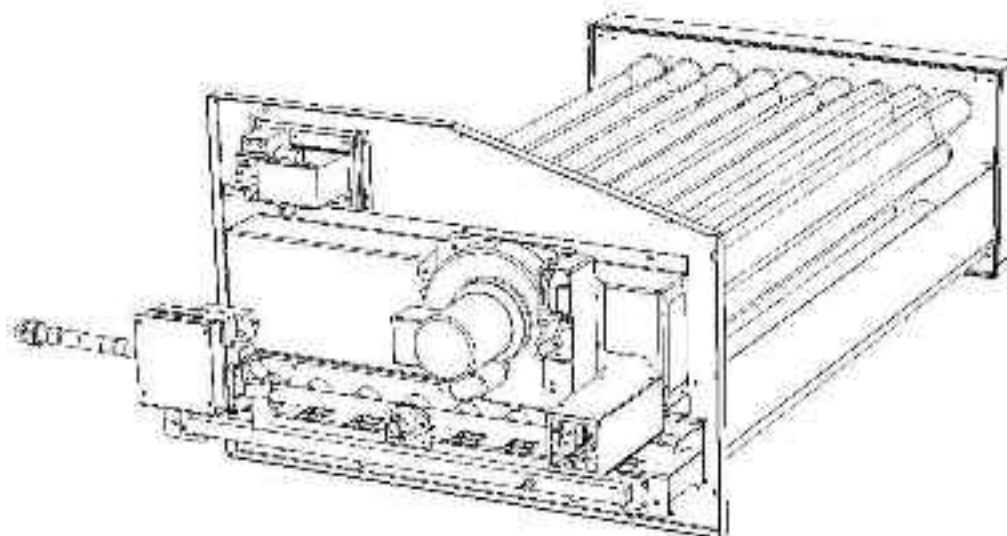

Fig. 72

MODULE-GAZ-60KW-E-BOX

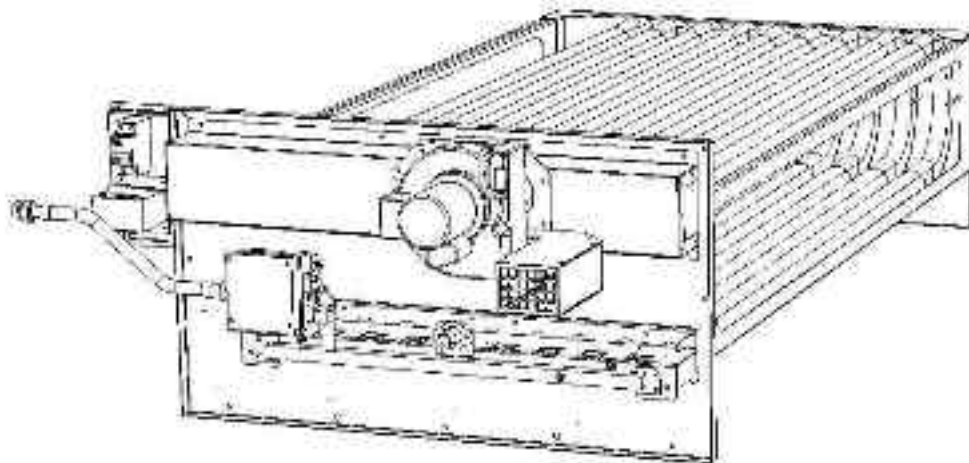

Fig.73

MODULE-GAZ-120KW-E-BOX

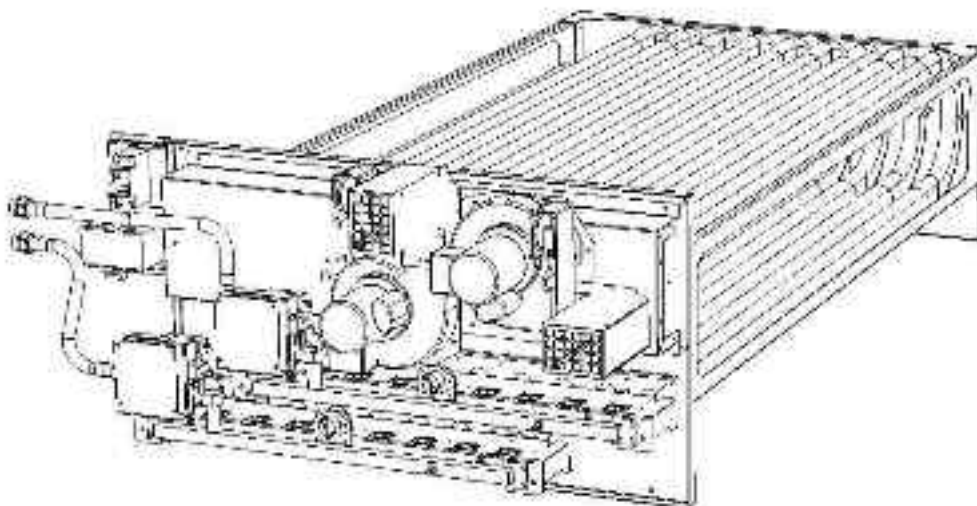

Fig. 74

MODULATING GAS (UNDER PATENT INPI Mai 2004)

The actuator



Fig. 75

The actuator receives an information 0-10V from the regulation for the positioning of the air shutter; then the actuator transmits its position to the printed-board which will order the valve.

Check position and operation of the actuator

Disengaging for hand drive operation



Manual rotation of the actuator

Fig. 76

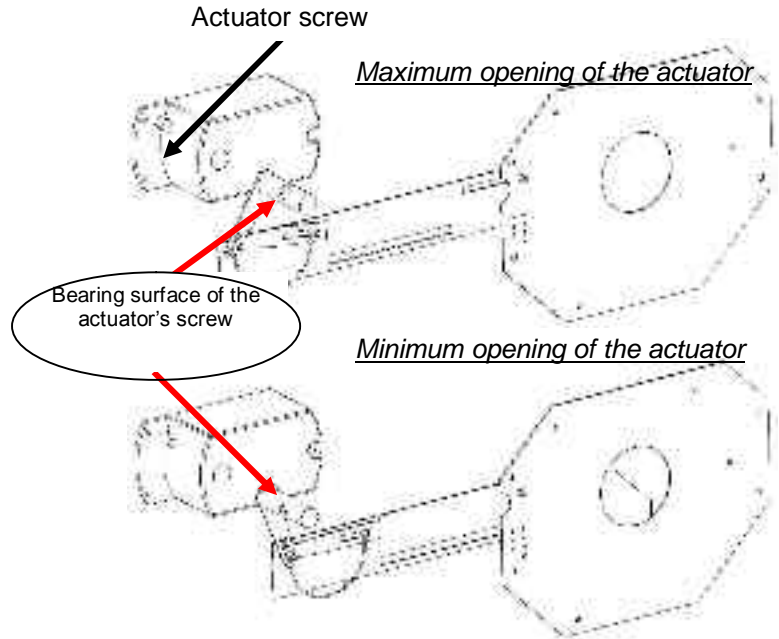

Fig. 77

STARTING UP THE GAS BURNER

Purge the pipe-work near the connection on the ignition control Valve for a few seconds.



Fig. 78

- -Check that the unit's Treatment Fan Blower is running.
- Set the control to "ON" This will priorities the gas burner.
- Increase the set temperature (room set point temperature) to a temperature higher than the actual room temperature.

The start of the gas burner must be done at **high heat injection.**

PRESSURE ADJUSTMENTS ON HONEYWELL PRESSURE REGULATING VALVE TYPE VK 4105 G

Pressure regulator adjustment with 300mbar gas supply:



Fig. 79

- The Burner must run in High Heat mode for this check.
- Place the tube of the “accurate” manometer on the **Inlet** pressure port (**Figure 80**) of the Gas Regulating Valve after having loosened the screw by one turn

Fig. 80

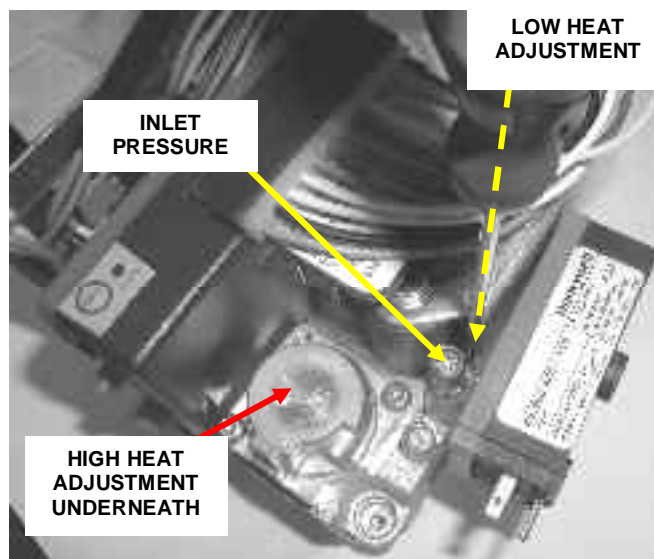

- Check and adjust if necessary the valve **Inlet** pressure to 20.0mbar (G20) (or 25.0mbar for G25)after gas burner ignition (fig.81)

Fig.81



High Heat Injection Pressure Checks

- Place the tube of the “accurate” Manometer to the **OUT** port on the Gas injector support bar after having loosened the screw by one turn.

Fig. 82



Check and adjust if necessary the valve **OUTLET** pressure to 8.4 mbar (G 20) (or 12.3mbar for G25) (fig.83)



Fig. 83

Low Heat Injection Pressure Checks

- Switch the control to Low Heat
- Check and adjust if necessary the **Outlet** pressure to 1.5 mbar minimum (G20) (or 2.25mbar for G25) (fig.85)
- After the adjustment of the low heat, re-verify the high heat
- Re-position the stoppers and close the pressure ports.

Fig. 84



Fig. 85

- After the adjustment of the low heat, re-verify the high heat
- Re-position the stoppers and close the pressure ports.

Pressure adjustments table for each type of gas (mbar)

Category	Supply pressure	Low Heat Injection mini.	High Heat Injection
G20	20.0 +/- 1	1.5 +/- 0.03	8.4 +/- 0.2
G25	25.0 +/- 1.3	2.25 +/- 0.05	12.3 +/- 0.2
G31	NA	NA	NA

Valve electrical control

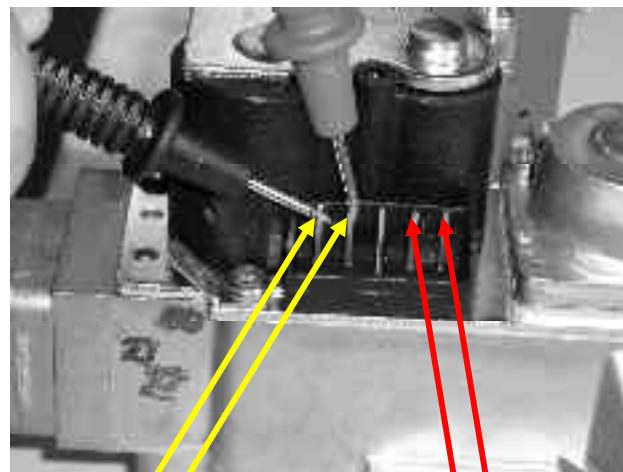

Fig. 86

2.90 kΩ

1.69 kΩ

- Check these values with an ohmmeter.

BURNER SAFETY CHECKS

Idem non-modulating gas burner

GAS BURNER TROUBLESHOOTING

Idem non-modulating gas burner.

If the valve's flow is not correct, check the operation of the actuator and of the mechanical assembly.

→ Replace the actuator if necessary

DISASSEMBLING THE GAS BURNER FOR MAINTENANCE PURPOSES

Idem non-modulating gas burner

MODULATING-GAZ-46KW-C-BOX

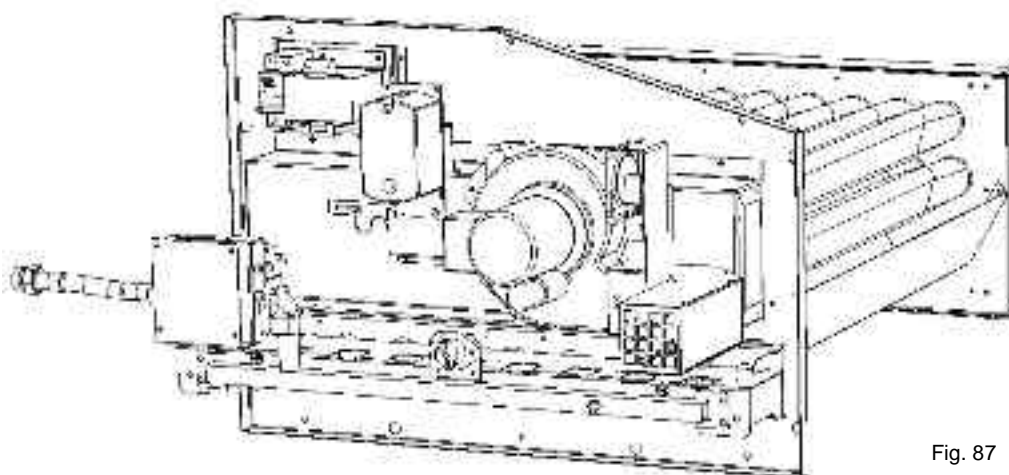

Fig. 87

MODULATING-GAZ-60KW-D-BOX

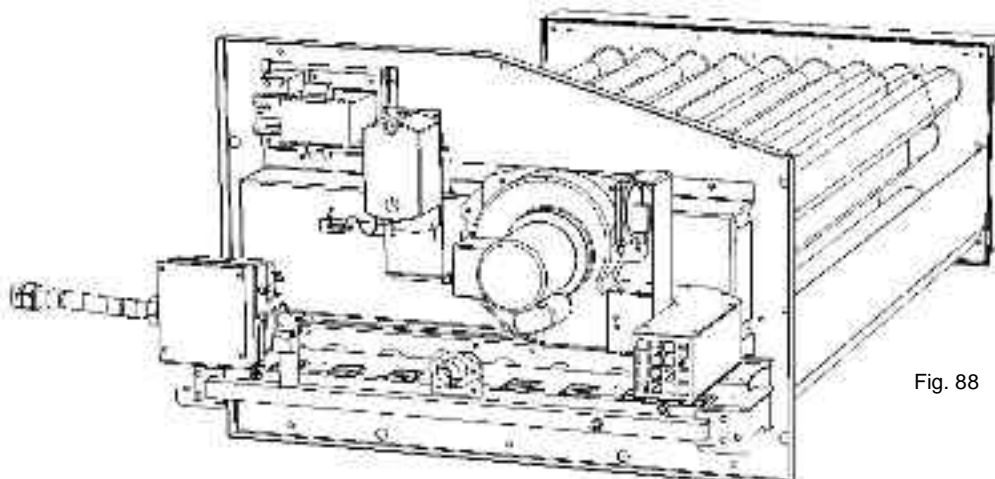

Fig. 88

MODULATING-GAZ-120KW-E-BOX

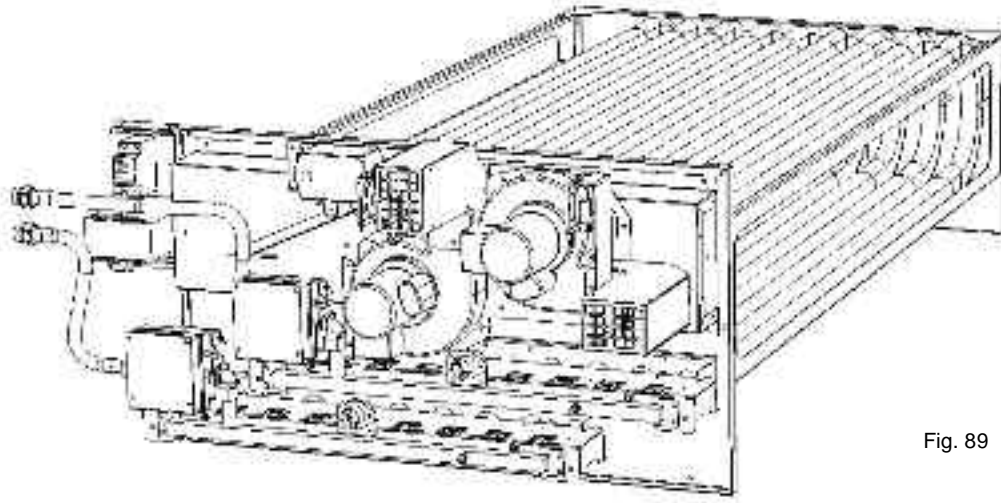

Fig. 89

TABLE OF CONTENTS

	Page
<u>WIRING CONNECTIONS</u>	
Important warning	94
Connection	94
Sensors and probes	94
DS 50 Display	94
DC 50 or DM 50 display (remote connection)	95
Connection on DT 50 derivator	95
Ferrites protection of display.....	96
DM 50 and Master/Slave communication	96
BMS communication	
 <u>CUSTOMIZED INPUT/OUTPUT</u>	
Digital Outputs Nc or No – Dry Contacts	98
Digital inputs 24V AC or DC.....	98
Analog inputs	99
Ambient temperature setpoint offset – 4-20 mA signal	99
Minimum fresh air setpoint – 4-20mA signal	99
Entry for a meteorological sensor.....	99
Input for meteorological sensor for relative humidity	99
Free temperature probe connection	99
Free relative humidity sensor connection	99
 <u>SCHEDULING – CLOCK SETTING</u>	
 <u>DC COMFORT AND DM 50 MULTI CUSTOMER DISPLAY</u>	
Buttons	101
Brightness / Contrast.....	101
Functions with DM 50	102
Main screen	102
3 hour override.....	102
Clock menu.....	103
“Programming” menu	103
Alarms.....	104
Start/Stop	105
1 week override.....	105
 <u>BMS address tables</u>	
Modbus, Trend, BACnet & CAREL	106
Lonworks.....	111
 <u>ERROR CODES</u>	 113

WIRING CONNECTIONS

Important Warning

Any wiring modification on the CLIMATIC 50 must be done by Lennox technician or employees having valid electrical qualification and authorisation.

For any modification of wiring on the 24V supply or on 4-20mA sensor, check the polarity prior to apply the power. Wrong polarity may cause serious damage and destroy the Plan network. Lennox will not accept liability for damage caused by wrong power connection or any wiring modification done by people without valid training and qualifications.

Any external connection with the unit, using 24Vac voltage should not exceed a length of more than 30m. It concerns external contacts connected to Climatic™ 50 logical inputs or humidifier control connection to the output 0-10v. Over 30 m, the installer must interface this information with relays or converters. In any case, the 24Vac control voltage must not be used to drive external function with Climatic™ 50 logical output

WARNING: Separate as much as possible probes, displays, logical input cables from power cables with strong inductive load, in order to avoid possible electromagnetic perturbations

Connection

Sensors and Probes

External sensors or probes connection must be carried out with the following cable:

Cable length up to 20m: AWG22 (0.34 mm²), 1 pair crossed with screen (2 pairs for CO2 sensor).

Cable length up to 50m: LiYCY-P (0.34 mm²), 1 pair with general shield. (2 pairs for CO2 sensor).

The cable length should not exceed 50m.

For a better electromagnetic protection, Lennox recommends the use of LiYCY-P cable

Room Temperature Probe (NTC)

The room temperature probe (- BT10) is connected to the Climatic™ main board BM50 50 entry B7 connector J6 (refer to the unit electrical wiring diagram).

Room Humidity Sensor (0-20mA / Option)

The room humidity sensor (- BH10) is connected to the Climatic™ extension board BE50 entry B1 connector J9 (refer to the unit electrical wiring diagram).

Room Air Quality Sensor CO² (4-20mA / Option)

The room air quality sensor (-BG10) is connected to Climatic™ main board BM50 entry B2 connector (refer to the unit electrical wiring diagram).

DS 50 Display

The Display DS50 can be connected to the Climatic™ either on one of the RJ12 connectors located on the board DT50, or directly on the main board BM50 connector J10.

Connection is carried out by the flat 1.5m cable delivered with this DS50.

In any the case, Display DS50 cannot be remotely connected.

In case of Master/Slave installation, one, and only one, display DS50 must be connected on the pLan bus.

Display DC50 or DM50 (Remote Connection)

Warning:

A wrong wiring of the display immediately damage it and/or the main board BM50.

- The optional DC50/DM50 is designed to be mounted on the wall.
- Fit the cable from the DT50 board through the back piece
- Fasten the back piece to the wall using the rounded head screws supplied in the packaging
- Connect the cable from the main board on the connector on the back of the DC50 display
- Fasten the front panel on the back piece using the flush head screws supplied
- Finally fit the click-on frame

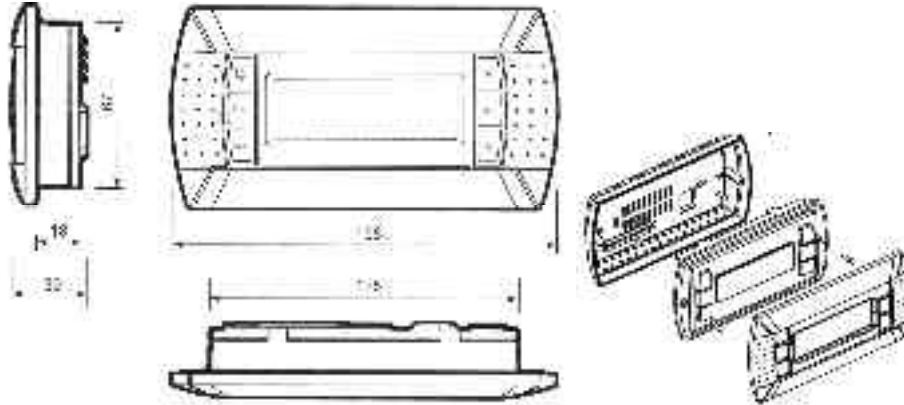

Display DC50 or DM50 is connected to the Climatic™ with the DT50 screw connector. Connection must be carried out by the following cable:

- Cable length up to 300m: AWG22 (0.34 mm²), 2 pairs crossed with screen.
- Cable length up to 500m: LiYCY-P (0.34 mm²), 2 pairs with general shield.

The cable length should not exceed 500m.

For a better electromagnetic protection, Lennox recommends the use of LiYCY-P cable

Connection on DT50 Derivator

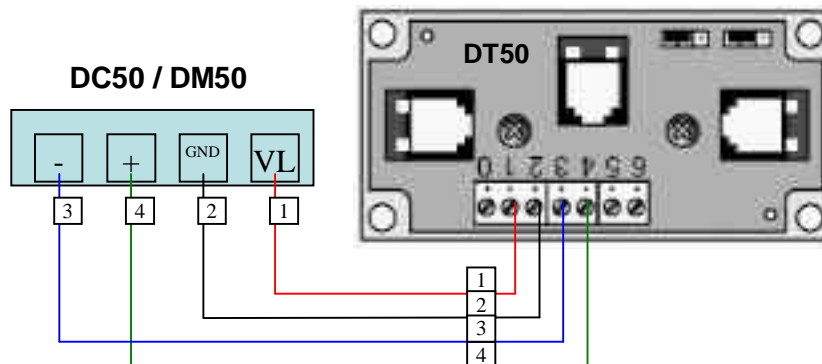

Terminal Connection Board Installation Guide DT 50

The board is fitted with three "telephone" RJ12 plugs. Ensure the board is correctly connected.

Ferrites Protection of Display

To avoid the appearance of disturbances HF, which can cause the destruction of components in the displays, you must equip the cable with a ferrite when installing it (provided by Lennox).

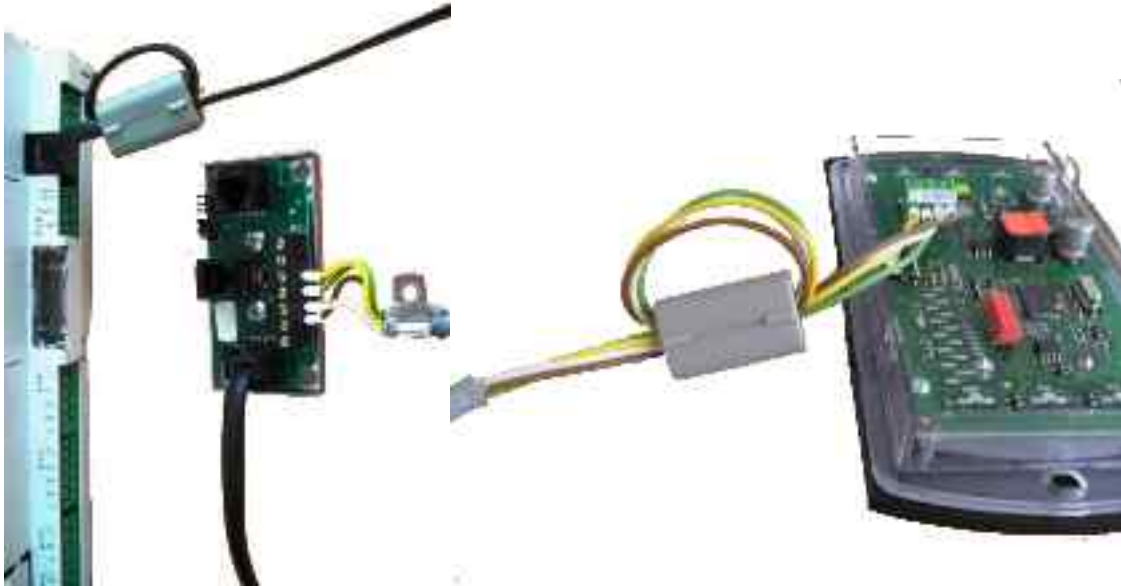

DM50 and Master/Slave Communication

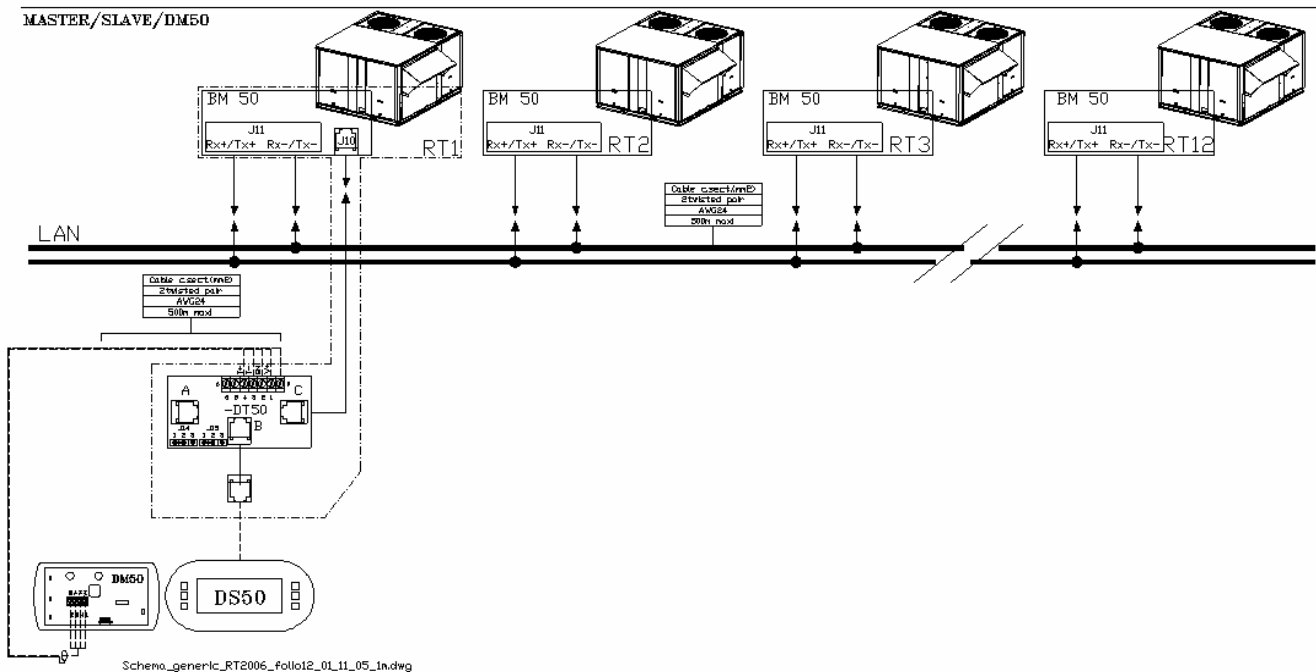

The intercard bus (pLAN) is connected to Climatic™ on the J11 connector of board BM50. A star connection is not recommended, for an optimum operation it is advised to connect a maximum of two cables per unit. Connection must be carried out by the following cable:

- Cable length up to 300m: AWG22 (0.34 mm²), 2 pairs crossed with screen.
- Cable length up to 500m: LiYCY-P (0.34 mm²), 2 pairs with general shield.

The cable length should not exceed 500m.
For a better electromagnetic protection, Lennox recommends the use of LiYCY-P cable

Warning:

The power 24Vac of boards BM50 should not be connected to the earth

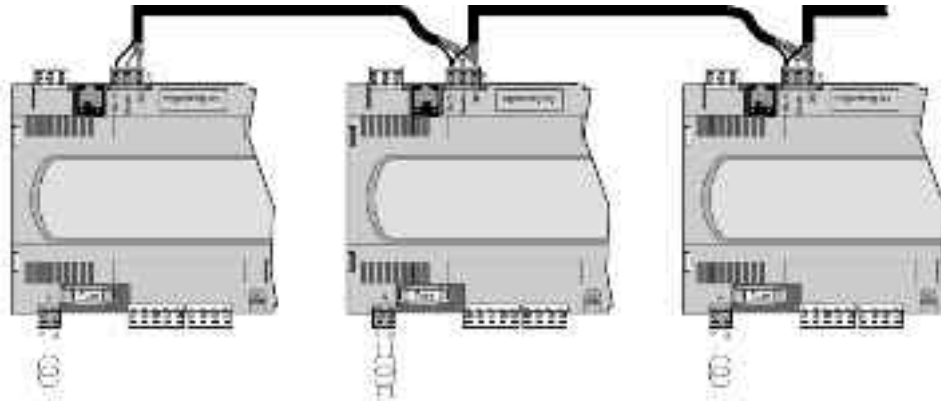

BMS Communication

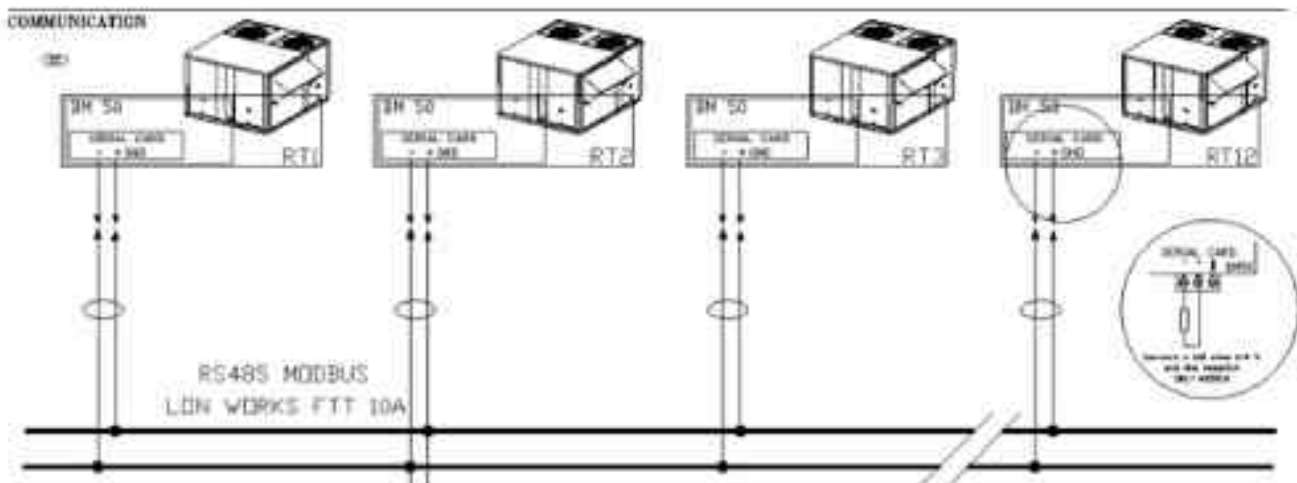

The communication bus is connected to Climatic™ Serial Card daughter board on the BM50. A star connection is not recommended, for an optimum operation it is advised to connect a maximum of two cables per unit. In case of RS485bus, a resistance of 120Ω 1/4W can be connected on the last unit between the terminals + and - . Connection must be carried out by the following cable:

- Cable length up to 300m: AWG22 (0.34 mm²), 2 pairs crossed with screen.
- Cable length up to 1000m: LiYCY-P (0.34 mm²), 2 pairs with general shield.

The cable length should not exceed 1000m.

For a better electromagnetic protection, Lennox recommends the use of LiYCY-P cable

CUSTOMIZED INPUT/OUTPUT

Function

On the BM.50 card and with the optional expansion board BE.50, it is possible to customize some input / output for remote control of the unit. So it is possible to customize

- 5 digital outputs NC or NO
- 6 digitals inputs
- 4 analogical inputs (4-20mA or Lennox NTC temperature probe)

Description

The following functions can be configured:

Digital Outputs Nc or No – Dry Contacts

The following items can be used for each output:

[Not Used.]	No contact
[Filter Al.]	Filter fault
[Blower Al.]	Blowing fan fault
[Comp. Al.]	Compressor fault
[Gas Al]	Gas fault
[ElecH. Al]	Electrical heater fault
[Frost. Al]	Alarm, freezing risk
[Smoke. Al.]	Smoke detector alarm
[Heat. Mode]	Heating mode
[Humidif.]	Humidifier control
[Z:A]	Unit operating Zone A
[Z:B]	Unit operating Zone B
[Z:C]	Unit operating Zone C
[Uno]	Unit operating Zone Unoccupied
[Bms]	Unit operating Zone BMS
[Free]	Free for BMS acting
[Exhaust 1]	Drive exhaust fan n°1
[Exhaust 2]	Drive exhaust fan n°2
[Exhaust 3]	Drive exhaust fan n°3

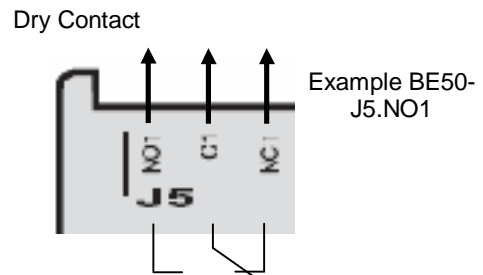

Digital Inputs 24V AC or DC

The following items can be used for each input:

[Not Used]	No contact
[Sw Unoc.]	Active Unoccupied Mode
[Dis. Cp/AH]	Stop of all compressors and auxiliary heating
[Dis. Comp.]	Stop of all compressors
[Dis. 50%Cp]	Immediate stop of 50% of the compressors
[Dis. AuxH.]	Stop of supplementary heating
[Sw Dis.Cool]	Cancellation of cooling mode
[Sw Dis.Heat]	Cancellation of heating mode
[State Hum]	Humidifier fault input
[0% F.A.]	Active 0% fresh air
[10% F.A.]	Add 10% fresh air
[20% F.A.]	Add 20% fresh air
[30% F.A.]	Add 30% fresh air
[40% F.A.]	Add 40% fresh air
[50% F.A.]	Add 50% fresh air
[100% F.A.]	Force 100% fresh air
[Low Speed]	Force low speed ventilation
[Z:A]	Active Unit operating in Zone A
[Z:B]	Active Unit operating in Zone B
[Z:C]	Active Unit operating in Zone C
[Uno]	Active Unit operating in Zone Unoccupied
[Bms]	Active Unit operating in Zone BMS
[Free]	Free for BMS system information.

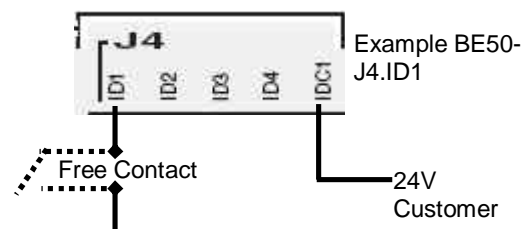

Analog Inputs

The following items can be used for each input:

- [Not Used]..... Not used
- [S.P Offset]..... Room temperature set point offset – 4-20mA signal.
- [F.A Offset]..... Minimum fresh air set point – 4-20mA signal.
- [Weather T.]..... Entry for a Meteorological temperature sensor
- [Weather H.]..... Entry for a Meteorological humidity sensor
- [Free NTC]..... Free temperature probe connection
- [Free Hr.]..... Free relative humidity sensor connection

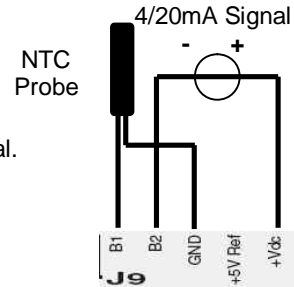

Example BE50-J9.B1, BE50-J9.B2

Ambient Temperature Set Point Offset – 4-20mA Signal:

The 4-20mA signal sent to the unit is linearly converted using a -5K to +5K range of temperature set point. For example: for a unit set point of 20°C
 A 4mA signal will give a 15°C unit temperature set point
 A 12mA signal will give a 20°C unit temperature set point
 A 20mA signal will give a 25°C unit temperature set point

Minimum Fresh Air Set Point – 4-20mA Signal:

The 4-20mA signal sent to the unit is linearly converted to a 0% - 100% fresh air damper opening request.

Entry for a Meteorological Temperature Sensor:

The 4-20mA signal sent to the unit is linearly converted using a -40°C to +80°C range, this measure will replace the one given by the unit sensor.

Input for a Meteorological Sensor for Relative Humidity:

The 4-20mA signal sent to the unit is linearly converted using a 0% to 100% range, this measure will replace the one given by the unit sensor.

Free Temperature Probe Connection:

Lennox NTC sensor.

Free Relative Humidity Sensor Connection:

The 4-20mA signal sent to the unit is linearly converted using a 0% to 100% range.

SCHEDULING – CLOCK SETTING

Scheduling

Function

Controlling operation of the unit according to the time and day

Description

CLIMATIC™ 50 can handle 4 time zones over the 7 days of the week:

- Zone unoccupied (Night)
- Zone A (Day A)
- Zone B (Day B)
- Zone C (Day C)

Each set point integrates the hour and minute's adjustment, thus a value of 8.3 equal 8.30 a.m.

		8h00	12h00	13h50	20h30	22h00
Monday	Unoccupied	Z :A	Z :B	Z :C		Unoccupied
Tuesday						
Wednesday						
Thursday						
Friday						
Saturday						
Sunday						

For each time zone, the set following set points following can be modified:

LIST SET POINT BY ZONE
Ambient temperature
Set point average
Set point dynamic
Minimum fresh air (%)
Programming
Beginning of zone; each day
Start Uno
Start z.A
Start z.B
Start z.C

Note: "Monday" is considered as the first day of the week for programming the CLIMATIC™50.

Factory settings:

"Day A" activated from Monday to Saturday 6h→22h
 Night mode (unoccupied) for the remaining of time, Sunday included

DC50 COMFORT & DM50 MULTI CUSTOMER DISPLAY



Function

This display is connected remotely; it is intended for users with no technical knowledge. This display gives access to general operating data of the unit; it does not give access to detailed operating data. It can be used to set or change the programming of the various time periods and the temperature set point for each period. It also has the ability to set a 3 hour override and force an unoccupied mode, or any other different time period, for a maximum of 7 days. It displays a real time clock and the various fault signals.

Description

Buttons



'Prg' Access set points



'Clock' Access the clock



'Esc' Return to the previous display



'Up' Access overrides or increase values



'Enter', Confirms the selection



'Down' Access overrides or decrease values

Brightness/Contrast

The display has a set contrast, but this can be adjusted manually. For manual adjustment of the contrast, press the 'Prg' and 'Clock' buttons simultaneously and press buttons ↑ or ↓ to increase or reduce the contrast.

Configuring the terminal address
Sdc.1



The address of the terminal (DC50 or DM50) must be checked after having switching on the card.

Access the configuration mode by pressing buttons ↑↓← simultaneously for at least 5 seconds, until the Sdc.1 screen appears. Press the 'Enter' button to position the cursor over the 'Setting' line. With button ↑ or ↓ set the address of the display. See table below for the DC50, the DM50 is always 31, then confirm with button ←

pLan address with BM50 connected	DC50 Address	pLan address with BM50 connected	DC50 Address
1	17	7	23
2	18	8	24
3	19	9	25
4	20	10	26
5	21	11	27
6	22	12	28

Sdc.2



The Sdc.2 screen appears.

If after 5 seconds the display is not correct;
 Return to the configuration mode by pressing buttons $\uparrow\downarrow\leftarrow$ simultaneously for at least 5 seconds until the Sdc.1 screen appears.
 Press button \leftarrow to position the cursor over the 'Setting' line
 Press, the button \leftarrow again to position the cursor over the 'I/O board address' line
 With the button \uparrow or \downarrow replace '-' with the address of the BM50 connected and confirm with button \leftarrow
 Then repeat the procedure "Allocation of Displays to the BM50"

Functions with DM50

The screens and functions of the DM50 are the same as the screens of the DC50.
 A DC must be connected to one, and only one, BM50. Even if the unit is connected to the pLan bus, the screens of the DC50 will only apply to the configured BM50.
 One DM50 may be connected to 12 units with the pLan bus. The screens of the DM50 will apply to one of the BM50 alternately.

Sdm.1



On the bottom line of the BM50 the symbol '→' indicates the BM50s identified on the pLan bus (number 1 on the left, up to number 12 on the right)
 A unit that is disconnected or switched off cannot be displayed by the DM50.
 The number in brackets at the bottom left indicates the number of the BM50 currently connected to the DM50.
 In the event of a fault on one or other of the BM50s identified, the 'Prg' button is illuminated in red and the symbol '→' for the units concerned flashes.
 To display another unit from the main display, press button \downarrow .

Main Screen

Sdc.3



On the first line, as a double display:
 Ambient temperature
 Fan on or off.
 On the second line:
 Degree of opening of the air regulator (option)
 'Dyn' if the offset function of the set point as a function of the outside temperature deviation is active.
 'Fan:Auto' if the fan start/stop in the dead zone of the adjustment function is configured.
 On the third line:
 Outside air temperature
 Current time period (Z: A, Z: B, Z: C, Uno, Ove and BMS)
 Mode of operation (Hot, Dead or Cold)

3 Hour Override

These functions can be used to override either the desired ambient temperature or the minimum air change rate for 3 hours.

Sdc.3



If an override is active, the time period display is altered with the 'Der' symbol
 The 'Esc' button is used to cancel the override mode.
 From the main screen, press button \uparrow or \downarrow
 (Press button \uparrow On the DM50)

Sdc.4



Screen Sdc.4 is used to change the override values
 The present time period is shown on the 2nd line. This period will remain fixed for 3 hours.
 Press **←** to position the cursor over the 'Room SP' line
 With button **↑** or **↓** set the desired temperature and confirm with the 'Enter' button.
 The cursor is positioned over the 'Min FA' line
 With button **↑** or **↓** set the desired air change rate and confirm with button **←**
 The DC50 returns to the main display.

If the unit is not fitted with the economiser option, only the temperature line is displayed.

A single press on the 'Esc' button cancels the changes and returns to the main screen.

It will revert back to the main screen after 15 seconds without any activity.

Clock Menu

These screens are used to display and change the time and date on the BM50.

Sdc.5



From the main screen, press the 'clock' button
 The Sdc.5 screen displays the time and date.

To change the time or date:
 Press **←** to position the cursor over the time.
 With button **↑** or **↓** set the time and confirm with button **←**
 Position the cursor over 'minutes'.
 With button **↑** or **↓** set the minutes and confirm with button **←**
 Position the cursor over 'month'.
 With button **↑** or **↓** set the month and confirm with button **←**
 Position the cursor over 'year'.
 With button **↑** or **↓** set the year and confirm with button **←**
 Position the cursor over 'hours'.

...

Pressing the 'Esc' returns to the main screen

It will revert back to the main screen after 15 seconds without any activity.

"Programming" Menu

These screens are used to display and change the set points of the BM50 for each time period.

Sdc.6



From the main screen, press the "Prg" button,
 Screen Sdc.6 displays the temperature set point and the minimum airflow rate.

If the unit is not fitted with the economiser option, only the temperature line is displayed.

With button **↑** or **↓** set the desired temperature and confirm with button **←**.
 The cursor is positioned over the 'Min. FA.' line
 With button **↑** or **↓** set the desired air change rate and confirm with button **←**.
 Position the cursor over the 'Room SP' line

Pressing the 'Esc' returns to the main screen.

The time period can be selected by repeatedly pressing the 'Clock' button,

Sdc.7



From the Sdc.6 screen; press the 'Prg' button
Screen Sdc.7 displays the period settings.

Position the cursor over period A
With button \uparrow or \downarrow set the start time for period A and confirm with button \leftarrow .
Position the cursor over period B.
With button \uparrow or \downarrow set the start time for period B and confirm with button \leftarrow .
Position the cursor over period C.
With button \uparrow or \downarrow set the start time for period C and confirm with button \leftarrow .
Position the cursor over the Uno period.
With button \uparrow or \downarrow set the unoccupied period and confirm with button \leftarrow .
Position the cursor over period A.
...

Pressing the 'Esc' returns to the main screen.
Select the day of the week by repeatedly pressing the 'Clock' button

It will revert back to the main screen after 15 seconds without any activity.

Alarms

Filter Alarm

Sdc.8



In the event of activation of a filter fault on the unit, screen Sdc.8 is displayed.
The 'Clock' button is illuminated.
All buttons are deactivated

The only way to regain control of the DC50 is to clean or replace the filters in the unit.

Major Alarm

Sdc.9



In the event of activation of a fault on the unit, screen Sdc.9 is displayed.
Button 'Prg' is illuminated.
All buttons are deactivated

* The only way to regain control of the DC50 is to resolve the fault on the unit.

To display the alarm history of the unit, press button \leftarrow

The history can store the last 32 alarms occurring on the unit.
Each alarm is memorised at the date and time of occurrence of the fault.

Sdc.10



An active alarm is signified by the symbol '*'.
An acknowledged alarm is signified by the symbol '='.
Each alarm is signified by a 3 digit code (see ERROR CODES)

Press the 'Alarm' button to reset all the alarms, if possible
The number of active alarms returns to 0, no active alarm is shown in the menu,
and the 'Alarm' button is no longer illuminated.

Sdc.11



To highlight the title of the error code, position the cursor over the line desired
with buttons \uparrow or \downarrow , then confirm with the 'Enter' button

Use the 'Esc' button to return to the previous levels.

Start/stop

Sdc.3



From the main screen, press the **←** button
The Sdc.12 screen appears.

Sdc.12



To stop the unit:
With button **↑** or **↓** set the value to 'Yes' and confirm with button **←**
The unit stops and the Sdc.13 screen appears

WARNING: Switching off the unit disables all the safety devices

Pressing the 'Esc' returns to the main screen.

Sdc.13



If the unit is stopped, the Sdc.13 screen appears.
To start the unit, press button **←**
The unit starts and the main screen appears.

1 Week Override

This function overrides the operating periods for a maximum of 7 days.

Sdc.14



From the Sdc.12 screen, press button **←** twice to position the cursor over the 'Override a period' line
With button **↑** or **↓** set the period desired and confirm with button **←**.

The Sdc.14 screen appears.
With button **↑** or **↓** set the days of the week to the period desired and confirm with button **←**.

In this example, the unit will remain in the unoccupied period on Tuesday when confirmed until midnight on Thursday.

BMS ADDRESS TABLES

ModBus, Trend, BACnet & Carel

Logical

@ (hexa)	@ (deci)				DS50
01H	1	R/W	L	[On / Off] Unit	3111
02H	2	R/W	L	[Reset] Discharges the safety measures of the unit	3112
03H	3	R/W	L	[Enable] Stopping and running of the Fan Blower.[Off] the blower is stopped, [On] the blower is running.	3351 (BMS)
04H	4	R/W	L	[Enable] Stopping and running of the fan in the "Control Dead Zone". [Off] the blower is stopped, [On] the blower is running.	3352 (BMS)
05H	5	R/W	L	[BMS] Activation of the Unoccupied mode [Off] Occupied mode - [On] Unoccupied mode	3935
06H	6	R/W	L	[Room regulation] Choices of the priority of regulation in Heating - [Off] Heat Pump then Hot water coil or Electric or Gas [On] Hot water coil or Electric or Gas then Heat Pump	3324 (BMS)
07H	7	R/W	L	[F-Air Reheat] Activate reheating of the fresh air in the dead zone to maintain supply temperature.	3331 (BMS)
08H	8	R/W	L	[F-Air Reheat] Choices of the priority of regulation in Heating - [Off] Heat Pump then Hot water coil or Electric or Gas [On] Hot water coil or Electric or Gas then Heat Pump	3332 (BMS)
09H	9	R/W	L	[Enable] Run eco: [On] the Economiser is running, [Off] the Economiser if stopped.	3353 (BMS)
0AH	10	R/W	L	[Enable] Run CO2 Sensor: [On] Switch-on the CO2 control on a Zone, [Off] Stop the CO2 control on a zone.	3354 (BMS)
0BH	11	R/W	L	[Enable] [OFF] Force the unloading of compressors in cooling mode.	3355 (BMS)
0CH	12	R/W	L	[Enable] [OFF] Force the unloading of compressors in heating mode.	3356 (BMS)
0DH	13	R/W	L	[Enable] [OFF] Force the unloading of heating module (electric, gas or heat water coil)	3357 (BMS)
0EH	14	R/W	L	[Enable] [OFF] Force the unloading of humidity control.	3358 (BMS)
0FH	15	R/W	L	[Unloaded] Force the stop of half of the compressors moving has the moment of the activation of this point.	3643
10H	16	R/W	L	[Clock] [OFF] read hour & minute [ON] write hour & minute	...
11H	17	R/W	L	[Dry contact] Digital Output, Free 1, BM50-J17-NO12	2141
12H	18	R/W	L	[Dry contact] Digital Output, Free 2, BE50-J5-NO1	2142
13H	19	R/W	L	[Dry contact] Digital Output, Free 3, BE50-J6-NO2	2143
14H	20	R/W	L	[Dry contact] Digital Output, Free 4, BE50-J7-NO3	2144
15H	21	R/W	L	[Dry contact] Digital Output, Free 5, BE50-J8-NO4	2145
16H	22	R/W	L	<i>not used</i>	
17H	23	R/W	L	<i>not used</i>	
18H	24	R/W	L	<i>not used</i>	
19H	25	R/W	L	<i>not used</i>	
1AH	26	R/W	L	<i>not used</i>	
1BH	27	R/W	L	<i>not used</i>	
1CH	28	R/W	L	<i>not used</i>	
1DH	29	R/W	L	<i>not used</i>	

CLIMATIC 50 – ROOFTOP – VERSION 23



@ (hexa)	@ (deci)				DS50
1EH	30	R/W	L	<i>not used</i>	
1FH	31	R/W	L	<i>not used</i>	
20H	32	R/W	L	<i>not used</i>	
21H	33	R	L	[Alarm] General	1000
22H	34	R	L	[On/Off] Fan, Blower	2315
23H	35	R	L	[On/Off] Fan, Extraction	2321
24H	36	R	L	[On/Off] Compressor, 1	2516
25H	37	R	L	[On/Off] Compressor, Heat pump, 1	2517
26H	38	R	L	[On/Off] Compressor, 2	2526
27H	39	R	L	[On/Off] Compressor, Heat pump, 2	2527
28H	40	R	L	[On/Off] Compressor, 3	2536
29H	41	R	L	[On/Off] Compressor, Heat pump, 3	2537
2AH	42	R	L	[On/Off] Compressor, 4	2546
2BH	43	R	L	[On/Off] Compressor, Heat pump, 4	2547
2CH	44	R	L	[On/Off] Gas, Burner, 1	2615
2DH	45	R	L	[On/Off] Gas, Burner, 2	2616
2EH	46	R	L	[On/Off] Gas, Burner, High power, 1	2617
2FH	47	R	L	[On/Off] Electrical heaters, 1	2625
30H	48	R	L	[On/Off] Electrical heaters, 2	2626
31H	49	R	L	[Dry contact] Digital Input, Free 1, BM50-J8-ID13	2151
32H	50	R	L	[Dry contact] Digital Input, Free 2, BM50-J8-ID14	2152
33H	51	R	L	[Dry contact] Digital Input, Free 3, BE50-J4-ID1	2153
34H	52	R	L	[Dry contact] Digital Input, Free 4, BE50-J4-ID2	2154
35H	53	R	L	[Dry contact] Digital Input, Free 5, BE50-J4-ID3	2155
36H	54	R	L	[Dry contact] Digital Input, Free 6, BE50-J4-ID4	2156
37H	55	R	L	<i>not used</i>	
38H	56	R	L	<i>not used</i>	
39H	57	R	L	<i>not used</i>	
3AH	58	R	L	<i>not used</i>	
3BH	59	R	L	<i>not used</i>	
3CH	60	R	L	<i>not used</i>	
3DH	61	R	L	<i>not used</i>	
3EH	62	R	L	[Room] Cool Mode	...
3FH	63	R	L	[Room] Dead zone Mode	...
40H	64	R	L	[Room] Heat Mode	...

Analogical

@ (hexa)	@ (deci)				DS50
01H	1	R/W	1 = 1 s	[BMS] Activation of the control by a computer or an automat - mode BMS is activated if this value is different from zero, This value is decreased every second	3934
02H	2	R/W	10 = 1.0°C	[Occupation][Room SP] Required maximum room temperature in °C. Cooling set point	3322 (BMS)
03H	3	R/W	10 = 1.0°C	[Occupation][Room SP] Required minimum room temperature in °C. Heating set point	3323 (BMS)
04H	4	R/W	10 = 1.0%	[Room SP] Required room minimum fresh air rate in % Middle of the dead zone.	3312 (BMS)
05H	5	R/W	10 = 1.0°C	[Unoccupied][Room SP] Required maximum room temperature in °C. Cooling set point	3322 (Uno)
06H	6	R/W	10 = 1.0°C	[Unoccupied][Room SP] Required minimum room temperature in °C. Heating set point	3323 (Uno)
07H	7	R/W	10 = 1.0%	[Humidity] Desired Maximum relative humidity in Room (in %). – Dehumidification set point.	3341 (BMS)
08H	8	R/W	10 = 1.0%	[Humidity] Desired Minimum relative humidity in Room (in %). – Humidification set point.	3342 (BMS)
09H	9	R/W		<i>not used</i>	
0AH	10	R/W		<i>not used</i>	
0BH	11	R/W		<i>not used</i>	
0CH	12	R/W	1 = 1h	[Clock] Hour	3121
0DH	13	R/W	1 = 1m	[Clock] Minute	3122
0EH	14	R/W	1 = 1	[Clock] Day of the month	3123
0FH	15	R/W	1 = 1	[Clock] Month	3124
10H	16	R/W	1 = 2001	[Clock] Year	3125
11H	17	R/W	10 = 1.0°C	[BMS] Room temperature coming from the BMS	2824
12H	18	R/W	10 = 1.0%	[BMS] Room humidity coming from the BMS	2828
13H	19	R/W	10 = 1.0°C	[BMS] Outdoor temperature coming from the BMS	2814
14H	20	R/W	10 = 1.0%	[BMS] Outdoor humidity coming from the BMS	2818
15H	21	R/W	1 = 1 ppm	[BMS] Air quality coming from the BMS	
16H	22	R/W		<i>not used</i>	
17H	23	R/W		<i>not used</i>	
18H	24	R/W		<i>not used</i>	
19H	25	R/W		<i>not used</i>	
1AH	26	R/W		<i>not used</i>	
1BH	27	R/W		<i>not used</i>	
1CH	28	R/W		<i>not used</i>	
1DH	29	R/W		<i>not used</i>	
1EH	30	R/W		<i>not used</i>	
1FH	31	R/W		<i>not used</i>	
20H	32	R/W		<i>not used</i>	
21H	33	R	1 = 1	[Alarm] Code Error	1000
22H	34	R	10 = 1.0°C	[Temperature] Room	2112
23H	35	R	10 = 1.0°C	[Temperature] Outdoor	2111

@ (hexa)	@ (deci)				DS50
24H	36	R	10 = 1.0°C	[Temperature] Supply	2113
25H	37	R	10 = 1.0°C	[Temperature] Return	2114
26H	38	R	10 = 1.0%	[Relative Humidity] Room	2122
27H	39	R	10 = 1.0 g/Kg	[Absolute Humidity] Room	2124
28H	40	R	10 = 1.0%	[Relative Humidity] Outdoor	2121
29H	41	R	10 = 1.0 g/Kg	[Absolute Humidity] Outdoor	2123
2AH	42	R	1 = 1 pa	[Flow] Differential pressure on the air, in Pascal	2131
2BH	43	R	1 = 1 ppm	[CO ²] Level in ppm	2132
2CH	44	R	10 = 1.0%	[% of opening] Damper of fresh air	2413
2DH	45	R	10 = 1.0%	[% of opening] Valve gas	2618
2EH	46	R	10 = 1.0%	[% of opening] Electrical heaters (Triac)	2627
2FH	47	R	10 = 1.0%	[% of opening] Hot water coil	2633
30H	48	R	10 = 1.0%	[% of opening] Humidifier	2714
31H	49	R	10 = 1.0°C	[Dry contact] Temperature, Free 1, BE50-J9-B1	2161
32H	50	R	10 = 1.0°C	[Dry contact] Temperature, Free 2, BE50-J9-B2	2162
33H	51	R	10 = 1.0°C	[Dry contact] Temperature, Free 3, BE50-J10-B3	2163
34H	52	R	10 = 1.0°C	[Dry contact] Temperature, Free 4, BE50-J10-B4	2164
35H	53	R	10 = 1.0%	[Dry contact] Humidity, Free 1, BE50-J9-B1	2165
36H	54	R	10 = 1.0%	[Dry contact] Humidity, Free 2, BE50-J9-B2	2166
37H	55	R	10 = 1.0%	[Dry contact] Humidity, Free 3, BE50-J10-B3	2167
38H	56	R	10 = 1.0%	[Dry contact] Humidity, Free 4, BE50-J10-B4	2168
39H	57	R	1 = 1 h	[Running Time, Count] Fan, Blower	2318
3AH	58	R	1 = 1 h	[Running Time, Count] Compressor, 1	2519
3BH	59	R	1 = 1 h	[Running Time, Count] Compressor, 2	2529
3CH	60	R	1 = 1 h	[Running Time, Count] Compressor, 3	2539
3DH	61	R	1 = 1 h	[Running Time, Count] Compressor, 4	2549
3EH	62	R	bit	[Alarm] bit.0 = Air Flow bit.1 = Dirty Filters bit.2 = No Filters bit.3 = Electrical heaters bit.4 = High Temperature, Supply bit.5 = Low Temperature, Room bit.6 = Gas Burner 1 bit.7 = Gas Burner 2 bit.8 = Low Temperature, Supply bit.9 = High Temperature, Room bit.10 = Humidifier bit.11 = Low Humidity, Room bit.12 = High Humidity, Room bit.13 = Pump bit.14 = Real Time Clock bit.15 = BE50	...



@ (hexa)	@ (deci)				DS50
3FH	63	R	bit	[Alarm] bit.0 = Probes & Sensors bit.1 = Fan, Blower bit.2 = Low Temperature, Condenser Water bit.3 = High Temperature, Condenser Water bit.4 = Flow Switch, Condenser Water bit.5 = Smoke Detector bit.6 = Fans, Condenser bit.7 = Compressor 1, H.P. & I.P. bit.8 = Compressor 1, L.P. bit.9 = Compressor 2, H.P. & I.P. bit.10 = Compressor 2, L.P. bit.11 = Compressor 3, H.P. & I.P. bit.12 = Compressor 3, L.P. bit.13 = Compressor 4, H.P. & I.P. bit.14 = Compressor 4, L.P. bit.15 =	...
40H	64	R		<i>not used</i>	

LonWorks

Type	Index pCO	Name NV	Type NV	Direction	Index pCO
ANL	1	I_Sp_T_Cool_BMS	105	input	1
ANL	1	O_Sp_T_Cool_BMS	105	output	1
ANL	2	I_Sp_T_Heat_BMS	105	input	2
ANL	2	O_Sp_T_Heat_BMS	105	output	2
ANL	3	I_Sp_T_Cool_Uno	105	input	3
ANL	3	O_Sp_T_Cool_Uno	105	output	3
ANL	4	I_Sp_T_Heat_Uno	105	input	4
ANL	4	O_Sp_T_Heat_Uno	105	output	4
ANL	5	I_Sp_Hr_DeHu_BMS	81	input	5
ANL	5	O_Sp_Hr_DeHu_BMS	81	output	5
ANL	6	I_Sp_Hr_Humi_BMS	81	input	6
ANL	6	O_Sp_Hr_Humi_BMS	81	output	6
ANL	17	O_T_Room	105	output	17
ANL	18	O_T_Outside	105	output	18
ANL	19	O_Ia_T_Supply	105	output	19
ANL	20	O_Hr_Room	81	output	20
ANL	21	O_Ha_Room	23	output	21
ANL	22	O_Hr_Outside	81	output	22
ANL	23	O_Ha_Outside	23	output	23
INT	1	I_Sp_BMS_Dog	8	input	208
INT	1	O_Sp_BMS_Dog	8	output	208
INT	2	I_Sp_EcoMini_BMS	8	input	209
INT	2	O_Sp_EcoMini_BMS	8	output	209
INT	3	I_Hour	8	input	210
INT	3	O_Hour	8	output	210
INT	4	I_Minute	8	input	211
INT	4	O_Minute	8	output	211
INT	5	I_Day	8	input	212
INT	5	O_Day	8	output	212
INT	6	I_Month	8	input	213
INT	6	O_Month	8	output	213
INT	17	O_Error_Codes	8	output	224
INT	18	O_Oa_Eco	81	output	225
INT	19	O_Oa_GasHeat	81	output	226
INT	20	O_Oa_TriacHeat	81	output	227
INT	21	O_Oa_HotWater	81	output	228
DGT	1	I_Sp_On_Unit	95	input	415
DGT	1	O_Sp_On_Unit	95	output	415
DGT	2	I_Sp_Reset	95	input	416
DGT	2	O_Sp_Reset	95	output	416
DGT	3	I_Sp_Unoc	95	input	417
DGT	3	O_Sp_Unoc	95	output	417
DGT	4	I_Clock	95	input	418
DGT	17	O_Od_Alarm	95	output	431

	DS50
[Occupation][Room SP] Required maximum room temperature in °C. Cooling set point	3322 (BMS)
[Occupation][Room SP] Required minimum room temperature in °C. Heating set point	3323 (BMS)
[Unoccupied][Room SP] Required maximum room temperature in °C. Cooling set point	3322 (Uno)
[Unoccupied][Room SP] Required minimum room temperature in °C. Heating set point	3323 (Uno)
[Humidity] Desired Maximum relative humidity in Room (in %). – Dehumidification set point.	3341 (BMS)
[Humidity] Desired Minimum relative humidity in Room (in %). – Humidification set point.	3342 (BMS)
[Temperature] Room	2112
[Temperature] Outdoor	2111
[Temperature] Supply	2113
[Relative Humidity] Room	2122
[Absolute Humidity] Room	2124
[Relative Humidity] Outdoor	2121
[Absolute Humidity] Outdoor	2123
[BMS] Activation of the control by a computer or an automat - mode BMS is activated if this value is different from zero, This value is decreased every second	3932
[Room SP] Required room minimum fresh air rate in % Middle of the dead zone.	3312 (BMS)
[Clock] Hour	3121
[Clock] Minute	3122
[Clock] Day of the month	3123
[Clock] Month	3124
[Alarm] Code Error	1000
[% of opening] Damper of fresh air	2413
[% of opening] Valve gas	2618
[% of opening] Electrical heaters (Triac)	2627
[% of opening] Hot water coil	2633
[On / Off] Unit	3111
[Reset] Discharges the safety measures of the unit	3112
[BMS] Activation of the Unoccupied mode [Off] Occupied mode - [On] Unoccupied mode	3933
[Clock] [OFF] read hour & minute [ON] write hour & minute	...
[Alarm] General	1000

CLIMATIC 50 – ROOFTOP – VERSION 23



Type	Index pCO	Name NV	Type NV	Direction	Index pCO
DGT	18	O_Od_Blower	95	output	432
DGT	19	O_Od_Comp_1	95	output	433
DGT	20	O_Od_CPac_1	95	output	434
DGT	21	O_Od_Comp_2	95	output	435
DGT	22	O_Od_CPac_2	95	output	436
DGT	23	O_Od_Comp_3	95	output	437
DGT	24	O_Od_CPac_3	95	output	438
DGT	25	O_Od_Comp_4	95	output	439
DGT	26	O_Od_CPac_4	95	output	440
DGT	27	O_Od_GasHeat_11	95	output	441
DGT	28	O_Od_GasHeat_2	95	output	442
DGT	29	O_Od_GasHeat_12	95	output	443
DGT	30	O_Od_ElecHeat_1	95	output	444
DGT	31	O_Od_ElecHeat_2	95	output	445

	DS50
[On/Off] Fan, Blower	2315
[On/Off] Compressor, 1	2516
[On/Off] Compressor, Heat pump, 1	2517
[On/Off] Compressor, 2	2526
[On/Off] Compressor, Heat pump, 2	2527
[On/Off] Compressor, 3	2536
[On/Off] Compressor, Heat pump, 3	2537
[On/Off] Compressor, 4	2546
[On/Off] Compressor, Heat pump, 4	2547
[On/Off] Gas, Burner, 1	2615
[On/Off] Gas, Burner, 2	2616
[On/Off] Gas, Burner, High power, 1	2617
[On/Off] Electrical heaters, 1	2625
[On/Off] Electrical heaters, 2	2626

ERROR CODES

001	"Airflow"	086	Circuit 1, Temperature sensor, Water condenser Outlet
004	Filters, Clogged up	087	Circuit 2, Temperature sensor, Water condenser Outlet
005	Filters, Missing	088	Temperature sensor, return or Mixing air
006	Recovery Module , Filters, Clogged up	091	Blower
011	Electric heating elements	092	Circuit 1, Condenser fan
012	High Temperature, Blowing	093	Circuit 2, Condenser fan
013	Low Temperature, Ambient	094	Circuit 3, Condenser fan
014	Gas burner, 1	095	Circuit 4, Condenser fan
015	Gas burner, 2	096	Low temperature, Water Condenser
022	Low Temperature, Blowing	097	High temperature, Water Condenser
023	High Temperature, Ambient	098	Flow rate, water condenser
031	Humidifier	099	Smoke detector
032	Low Humidity, Ambient	111	Circuit 1, Probe or Sensor
033	High Humidity, Ambient	115	Circuit 1, High pressure or electrical protection
041	Pump	117	Circuit 1, Low pressure
051	Recovery Module, Motor failure	118	Circuit 1, Risk of Frosting
052	Recovery Module, Wheel failure	121	Circuit 2, Probe or Sensor
070	Clock card	125	Circuit 2, High pressure or electrical protection
071	BE50, 1	127	Circuit 2, Low pressure
072	BE50, 2	128	Circuit 2, Risk of Frosting
081	Temperature sensor, Ambient	131	Circuit 3, Probe or Sensor
082	Humidity sensor, Ambient	135	Circuit 3, High pressure or electrical protection
083	Temperature probe, Outside	137	Circuit 3, Low pressure
084	Humidity sensor, Outside	141	Circuit 4, Probe or Sensor
085	Temperature probe, Blower	145	Circuit 4, High pressure or electrical protection
		147	Circuit 4, Low pressure

BCD	Condenser coil	B42	Compressor -MG2 high pressure safety switch	FD	Filter drier
BEC	Hot water coil	B51	Compressor -MG1 low pressure safety switch	MC1 - MC2	Condenser - MC1 - MC2 fan motor
BEV1	Evaporator coil	B52	Compressor -MG2 low pressure safety switch	MG1 - MG2	Compressor
BT12	Blower temperature sensor	B61	HP switch control for defrost	MS1	Blower fan motor MS1
B14	Hot water coil antifreeze thermostat	B62	HP switch control for defrost	YV2	Hot water 3-way valve
B17	Return Regulation Temperature Sensor	CA	Check valve	YV11	Compressor -MG1-MG2 Cycle reversible valve
B41	Compressor -MG1 high pressure safety switch	DT	Thermostatic expansion valve	B8	Discharge Gas thermostat
				B9	

BAH 020 to 030 single circuit

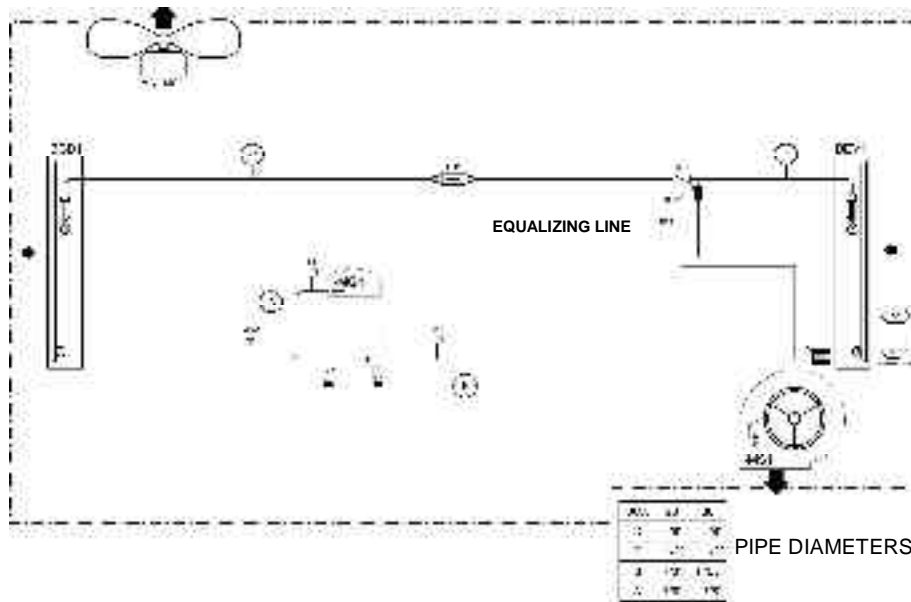

BAC 020 to 030 single circuit

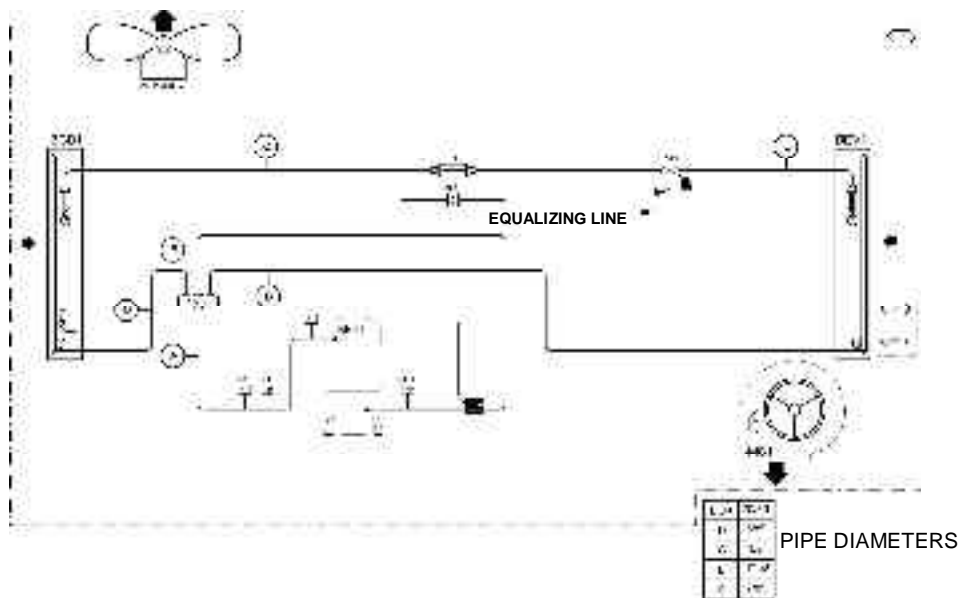

BAH 035 to 055 dual circuit

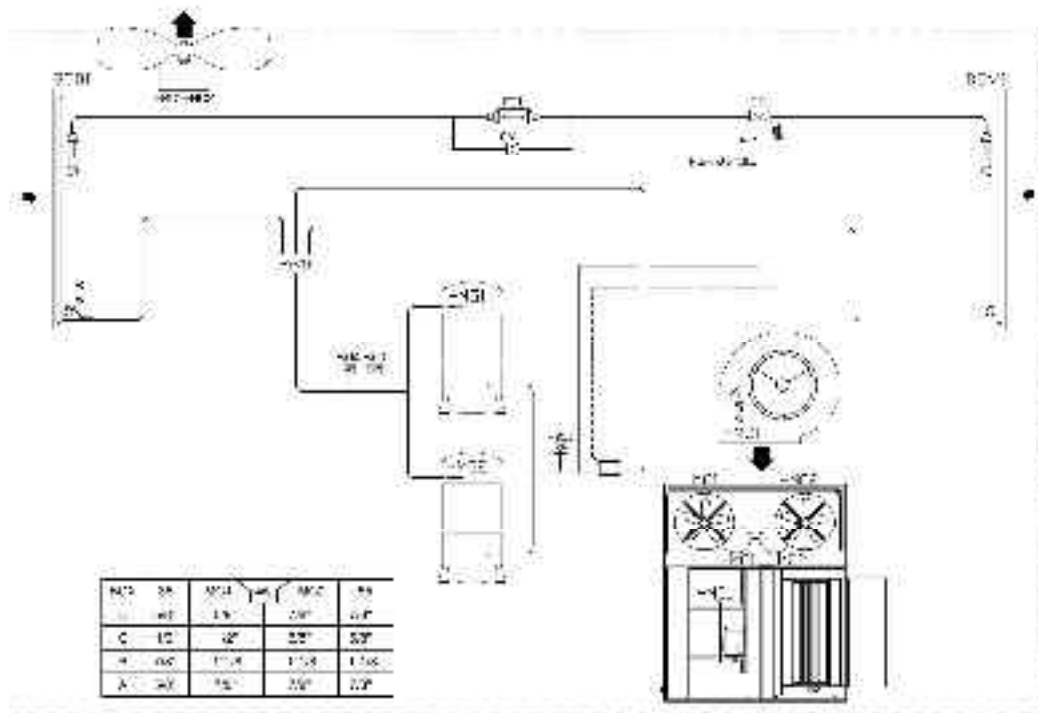

BAC 035 to 055 dual circuit

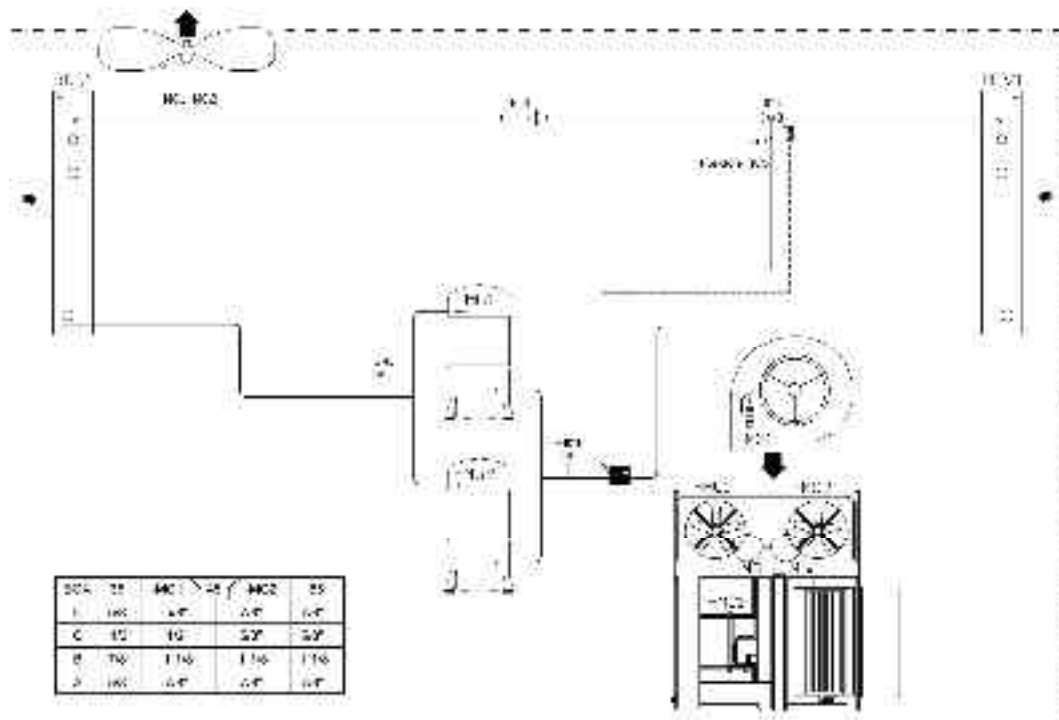

BAH 065 to 075 dual circuit

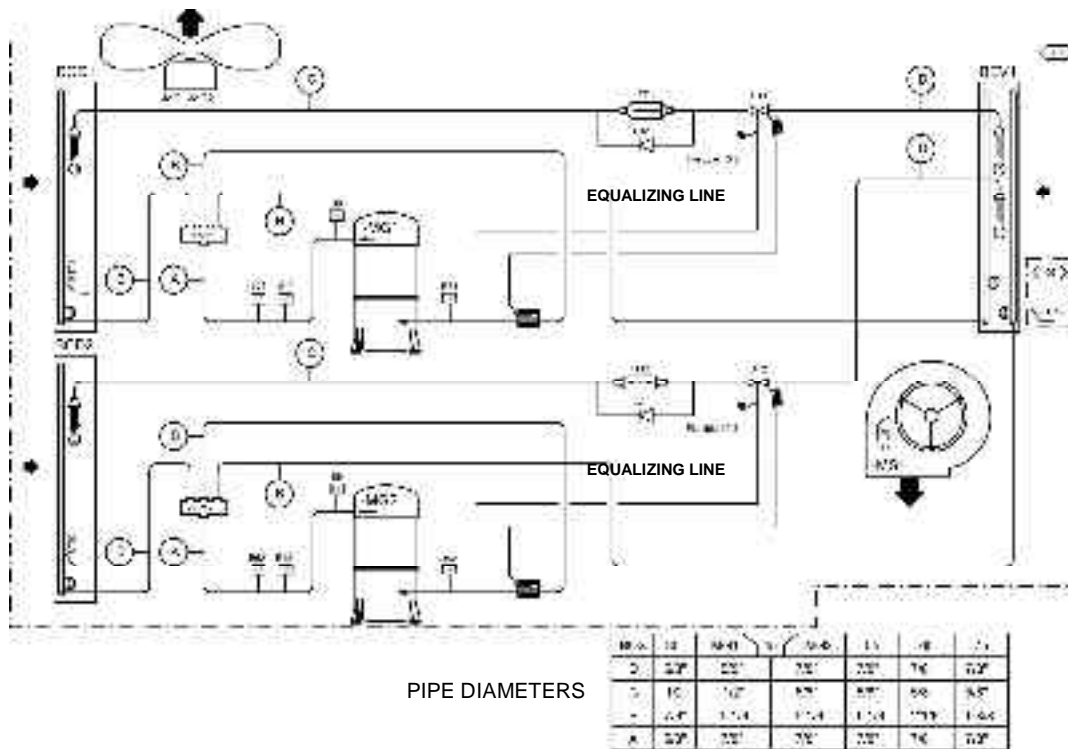

BAC 065 to 075 dual circuit

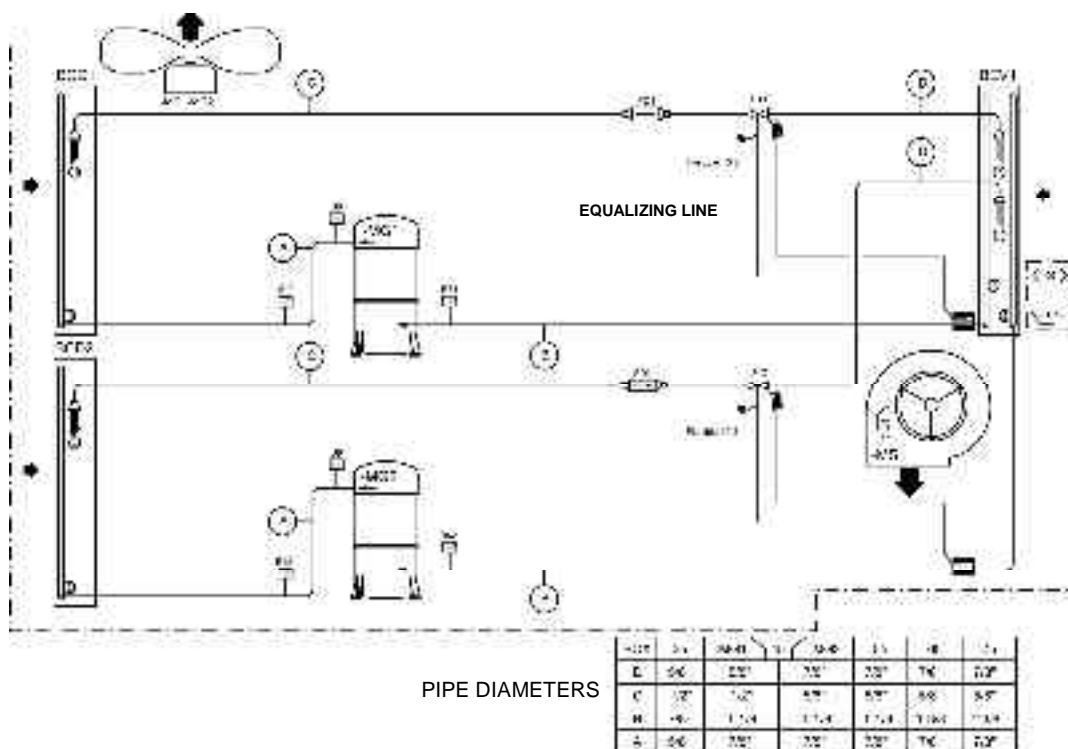

NOTA:

- * Maximum supply pressure: 8bar
- * Maximum temperature: 110°C

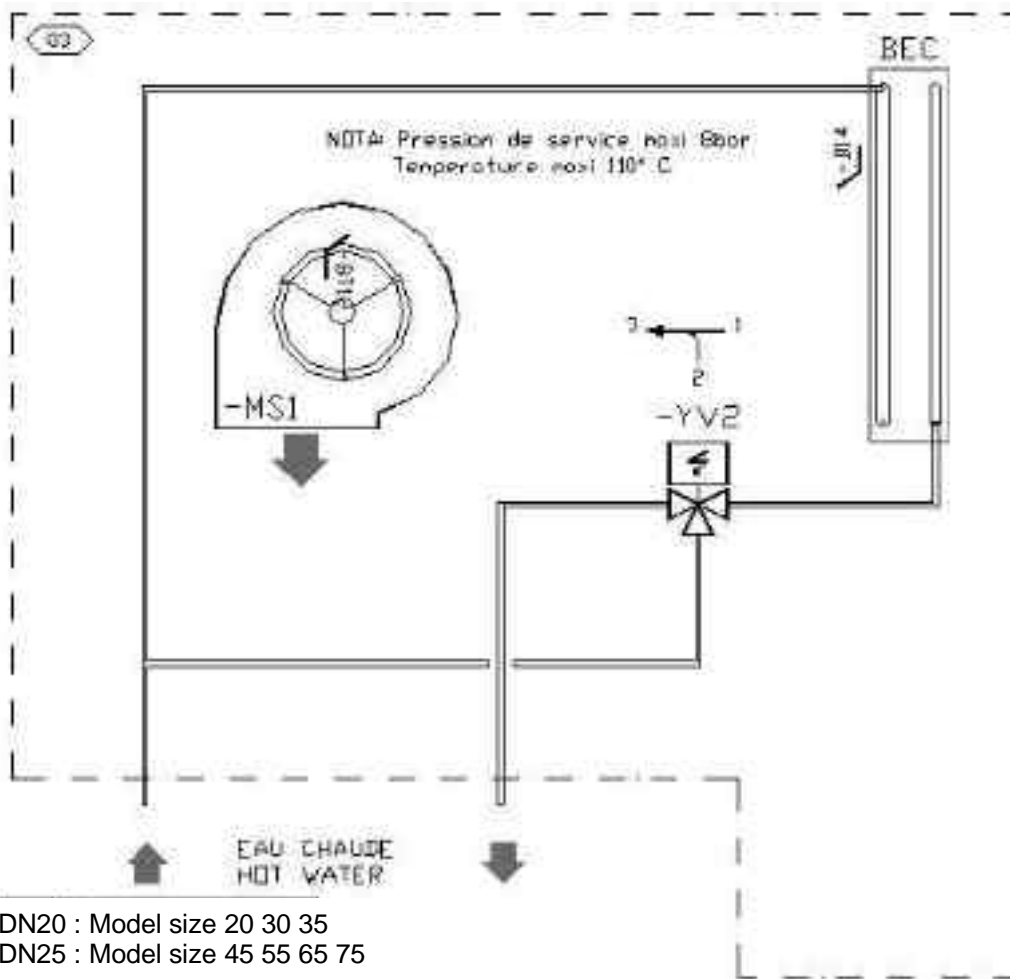

REFRIGERATION

FAULT	POSSIBLE CAUSE AND SYMPTOMS	SOLUTION
LP PROBLEMS and LP CUT OUTS	Refrigerant charge too low	Measure the superheat and sub-cooling: Good if 5°C<SC<10°C and 5°C<SH<10°C Bad if SC>10°C and SH too Low Check superheat adjustment and charge unit (a leak check must be carried out)
	In Heat Pump Mode the temperature difference between T outdoor and Tevap. (Dew) is too high 5°C < Delta T < 10°C excellent 10°C < Delta T < 15°C acceptable 15°C < Delta T < 25°C too high	If too high check the coils are clean or check coil internal pressure drop between the liquid line and the suction line Good if < 3bar Too high if > 3bar (coil blocked)
	Refrigeration circuit blocked in distribution	Stop the fan and create icing of the coil. Check all circuits freeze evenly across the whole surface of the coil If some parts of the coil do not freeze this could indicate a problem with the distribution
	Liquid line drier blocked. High temperature difference between inlet and outlet of the drier	Change filter drier
	Contaminant in the expansion valve	Attempt to free the valve adjusting element by freezing the valve and then heating the thermostatic element. Replace the valve if necessary
	Expansion valve not adjusted properly	Adjust the expansion Valve
	Ice plug in the expansion valve.	Heat the main body of the valve. If the LP increases and then decreases gradually, empty the circuit and replace the drier.
	Incorrect insulation of the thermostatic bulb of the expansion valve	Superheat too low: adjust superheat Move the thermostatic element along the pipe Insulate the Thermostatic element of the valve
	Low Pressure Switch cut out point too high	Check the cut out pressure of the Low Pressure switch: It must be 0.7+/- 0.2bar and must closes at 2.24 +/- 0.2 bar
	LP cut out due to not enough defrost on heat pumps	Adjust the CLIMATIC settings to extend the defrost cycles or shorten the time between defrosts
HP PROBLEMS AND HP CUT OUTS	Incorrect Airflow rates	Heat pump mode: Check the filter before the indoor coil measure and estimate the airflow rate increase the speed of the fan Cooling mode: Check the condenser fan (Amps)
	Moisture or contaminants in the system	Summer operation Several hours after the unit has stopped, check the correspondence between the measured pressure and the outdoor temperature

HP PROBLEMS AND HP CUT OUTS	Moisture or contaminants in the system	If the circuit pressure is higher (<1bar) than the saturated pressure corresponding to the measured outdoor temperature, there is possibility that some contaminants are present in the system. Reclaim the refrigerant, and vacuum the circuit (Ensure very low and slow vacuum for R407c) Recharge the unit
	Condenser coil is obstructed	Check the condenser coil and clean is necessary
	Recycled Hot Air	Check clearance around the condenser
Strong variations of pressure (2 to 3 bar) Thermostatic Expansion Valve "hunting"	Incorrect adjustment of the expansion valve Low refrigerant charge Filter drier obstructed with gas bubbles at the expansion valve inlet Moisture in the system	Refer to LP problems and LP cut out section
Very high discharge temperature, High amps measured at compressor	Very high superheat, very hot compressor	Open the superheat adjustment on the expansion valve. Check the pressure drop on the filter drier in the suction line
	Four Way reversing valve possibly blocked, abnormal noise from the valve, low LP and increasing HP	Check operation of the valve by going through cycle inversions. Change if necessary. Refer to LP problems

INDOOR FAN BLOWER

FAULT	POSSIBLE CAUSE AND SYMPTOMS	SOLUTION
High amps on action Fan motor	Pressure drop in the ducting installation too low.	Reduce the rotation speed of the fan Measure and estimate the airflow and pressure and compare with the specification from customer.
High amps on reaction Fan motor	Pressure drop in the ducting installation too high.	Reduce the rotation speed of the fan Measure and estimate the airflow and pressure and compare with the specification from customer.
Unstable running and high vibration	Fan jumping from one operating point to the other	Change rotation speed of the fan.

OUTDOOR AXIAL FAN

FAULT	POSSIBLE CAUSE AND SYMPTOMS	SOLUTION
Heat Pump mode: Circuit breaker open	High Amps due to a low voltage from the main supply	Check the voltage drop when all components are running. Change the circuit breaker for one with a higher rating.
	High amps due to freezing of the coil	Check the adjustable amps on the motor starter. Adjust the defrost cycle set points.
	Flexy: Water ingress in the motor connection box.	Change the component

ELECTRIC HEATER

FAULT	POSSIBLE CAUSE AND SYMPTOMS	SOLUTION
High Temperature trip out on electric heater	Low airflow rate	Measure and estimate the airflow and pressure and compare with the specification from customer.
	Incorrect position of the Klixon	Check that the Klixon, is positioned in the airflow, relocate Klixon if necessary Check that there is no heat transfer from the Klixon support.

WATER LEAKS

FAULT	POSSIBLE CAUSE AND SYMPTOMS	SOLUTION
Water found in the ventilation section	Cooling mode: Water carried away from the coil because of excessive airflow and speed on the coil.	Estimate the airflow rate and check the speed is lower than 2.8 m/s
	Low air pressure in the compartment due to a high airflow rate or a high pressure drop before the fan	Check filter Reduce airflow rate
	Check seals around the ventilation section.	Check the door seal Check for the presence of silicone seals in the corners of the door and at the bottom of the refrigeration section bulkhead.
Water ingress in the filter compartment	Water ingress through a leaking fresh air hood or when running 100% fresh air	Check the seals and flanges in the fresh air hood Reduce the airflow rate if necessary

DC50 & DS50

FAULT	POSSIBLE CAUSE AND SYMPTOMS	SOLUTION
DC50: Nothing is written on the screen but it's enlightened	Problem of addressing pLAN on the DC50	Press on the three right-hand side's buttons at the same time during a few seconds then reconfigure the terminal address (Confer DC addressing procedure)
DS50: Nothing is written on the screen but it's enlightened	Idem	Press on the three right-hand side's buttons at the same time during a few seconds then reconfigure display address setting at 32.
Nothing occurs on the unit or an option disappeared	Possible problem of units' configuration	Check the instructions from 3811 to 3833 and reconfigure options if necessary.
DS50 & DC50: the message "No Link" appears	Problem of addresses' recognition	Disconnect the DS50 from the unit and then reconnect it.
All the units are extinct	Problem BM50 pLAN addressing	Disconnect then re-plug; disconnect each unit from the others then change all the pLAN addresses

Rooftops are generally placed on the roof but can also be installed in technical rooms. These units are very robust but a minimum regular maintenance is required. Some moving parts in the units can suffer from wear and tear and must be checked regularly (belts). Other parts can get clogged by dirt carried in the air (filters) and must be cleaned or replaced.

These units are designed to produce cooled or heated air through the use of a refrigeration vapour compression system, it is therefore imperative to monitor the refrigeration circuit operating pressures and check the pipe-work for leaks.

The table below, details a possible maintenance plan, including the operations to be carried out and the periodicity at which they must be accomplished. It is recommended to follow such a plan to keep a rooftop unit in good working order. Regular maintenance of your rooftop will extend its operating life and reduce operating faults

Symbols and Legend :

- X** Operation which can be carried out by on-site maintenance technicians.
- Operation which **must** be carried out by qualified refrigeration personnel, trained to operate on this type of equipment.

NOTE :

- Times are given for information purpose only and may vary depending on the unit size and type of installation.
- Coil cleaning must be carried out by qualified personnel using appropriate methods that won't damage the fins or the tubes.
- It is recommended to keep a minimum stock of common replacement parts in order to be able to carry out regular maintenance operations (i.e. filters). You can contact your local Lennox representative which can assist you in establishing a parts list for each type of equipment.
- The access ports to the refrigeration circuits **MUST** be leak checked every time gauges are connected to the service ports.
- **For all important part replacement (fan, motor, damper, compressor), it is recommended to contact your local Lennox representative for a complete technical assistance**

Task	Operating mode	Monthly	Quarterly	6 monthly	Yearly B4 winter	Estimated Time (min)
Clean or replace filters: Disposable, or metal frame.	Replace filters with new ones if disposable. Vacuum clean or blow the dirt. Wash and dry carefully. Replace media if necessary. Blocked filter will reduce the performance of the unit. THE UNIT MUST NOT OPERATE WITHOUT FILTERS	o				20
Visual check of the oil level	Visually check the oil level through the sight glass on the side of the compressor casing	o				2
Position check of the compressor crankcase heater.	Check the heating resistance is fitted properly and tight around the compressor body.	o				2
Belt tension check. Pulley tightness check.	Check belt tension (Info in IOM) Replace belt if necessary. Check Pulley fixing screw tightness.	o				10
Centrifugal fan bearings check	Isolate unit from the main power supply; Push the fan wheel manually and check for abnormal noises. Bearings are lubricated for life but may need replacement after 10000 hours	o				10
Check absorbed Amps	Check absorbed Amps on all three phases; compare with the nominal value given in the electrical wiring diagram.		□			15
Check Smoke detector	Start the unit. Trigger the smoke detector by moving a magnet around the detector head. Reset unit and control.		□			5
Check Climatic control, set-points and variables	Refer to the commissioning sheet; Check all set points are set according to this document.		□			15
Check clock settings	Check the time and date of the control		o			5
Check the position and tightness of refrigeration components	Check systematically all connections and fixings on the refrigeration circuit. Check for oil traces, eventually a leak test should be conducted. Check operating pressures correspond to the ones indicated on the commissioning sheet		□			30
Check Airflow rate safety switch (if fitted).	Shut down supply fan. The fault must be detected within 5 seconds.			o		
Check freeze protection on HWC				□		5
Check three way valve on HWC	Increase room set-point 10°C above the actual room temperature. Check operation of the piston. It must move away from the valve head. Reset the control.			□		5
Check economiser actuator operation	Check all fixings and transmission. Stop the unit using the control. The fresh air damper must close. Start the unit the fresh air damper should open			□		5
Check refrigeration 4way valve	With the unit running in cooling mode increase the room set-point temperature by 10°C. The unit should switch to heat pump mode. Reset the control.			□		5
Check tightness of all electrical connections	Power down the unit and check and tighten all screws, terminal and electric connections, taking a particular attention to the power lines and low voltage control wires			o		30
Check HP / LP safety switches	Install manifold gauges on the circuit to be checked. Shut down the axial fans and wait for the HP switch to shut down the compressor: 29bar (+1 / -0) auto-reset 22bar (+ - 0.7) Reconnect fans. Switch off the centrifugal supply fan and wait for the LP switch to cut out: 0.5bar (+ - 0.5) reset 1.5bar (+0.5).			□		15

Task	Operating mode	Monthly	Quarterly	6 monthly	Yearly B4 winter	Estimated Time (min)
Check outdoor fans and fan guards	Check the fan blades conditions and all fan guards and protections				o	5
Check position of all sensors	Check the good positioning and operation of all sensors of all sensors. Check the values given in the control system. Replace sensor if necessary				o	5
Check and clean if necessary all fresh air grilles	Check the fresh air grilles (if fitted). If dirty or damaged, remove them from unit and clean with high pressure water cleaner. Refit on unit once clean and dry.				o	5
Clean condensate drain, indoor and outdoor coils (following local regulations)	Visually check the coils for dirt. If not too dirty, cleaning with a light brush may be enough (WARNING: Fins and copper tubes are very fragile! Any damage WILL reduce the performances of the unit). If very dirty, deep industrial cleaning is required using de-greasing agents.(External contractors must be called).				o / □	1h if cleaning
Check electric heater element for excessive corrosion	Isolate the unit; Pull the electric heater out of the heater module box and check the resistances of traces of corrosion; Replace resistance as required;				o	1h if replacement
Check anti-vibration mountings, for wear and tear.	Visually check anti-vibration mountings on compressors and centrifugal fan. Replace if damaged.				o	1h if replacement
Check refrigeration circuit for traces of acid in the oil	Take a sample of oil from the refrigeration circuit.				□	
Check Glycol concentration in the HWC circuit	Check the glycol concentration in the pressurised water circuit. (a concentration of 30% gives a protection down to aprox. -15°C) check the circuit pressure				□	30
Check defrost cycle with 4-way valve inversion.	Switch the unit to heat pump mode. Change the set point to obtain the standard defrost mode and reduce the cycle time to the min value. Check the operation of the defrost cycle.				□	30
Gas burner module check for corrosion	Pull out the burner to access the tubes (refer to Gas burner section in the IOM)				□	30
Sweeping and cleaning the gas burner	Clean the in-shot burners and the blower wheel lightly with a brush. Sweep the flue and flue box. Wipe-off the dust from the housing of the motor. Clean combustion air inlet louvers Pull-out baffles from the tubes, sweep the tubes CHECK FLUE BOX GASKET				□	30
Gas supply pressures / connections checks	refer to Gas burner section in the IOM for details				□	15
Gas regulation valve settings	refer to Gas burner section in the IOM for details				□	30
Check gas burner safety switches	refer to Gas burner section in the IOM for details				□	30

TERMS AND CONDITIONS

In the absence of any other written agreement, the guarantee shall only apply to design faults which occur within a 12 month period (warranty period).

The warranty period starts on the date of commissioning and at the latest six months after the delivery of the Rooftop.

ANTI-CORROSION WARRANTY**10 year warranty terms and conditions for corrosion to the Rooftop casing:**

Lennox shall guarantee the casing of its Rooftop units manufactured since May 1991 against corrosion for 10 years commencing from the date of delivery of the material.

The warranty shall not apply in the following cases:

1. If the corrosion of the casing is caused by external damage to the protective layer such as scratches, projections, abrasion, impacts etc...
2. If the casing is not kept continually clean in the course of maintenance work or by a specialist company,
3. If the casing is not cleaned and maintained in accordance with regulations,
4. If the Rooftop units are installed on a site or in an environment which is known to be corrosive, unless a special protective coating has been applied by the owner for these applications, which has been recommended by a competent body not linked to the owner and after carrying out a study of the site.
5. Nevertheless the LENNOX coating is highly resistant to corrosion, the warranty will not be applied for rooftop installed at less than 1000m away from the sea

Note: With the exception of the casing, the rest of the machine is covered by the warranty of our general terms of sale.

DO NOT CONFUSE THE WARRANTY WITH MAINTENANCE

The warranty will only apply if a maintenance contract has been signed, starting from the date of commissioning, and if the maintenance contract has actually been performed.

The maintenance contract must be made with a specialist, competent company.

The sole effect of any repair, modification or replacement of an item during the warranty period must be to extend the material's warranty period.

Maintenance must be carried out in accordance with regulations.

If a spare part is supplied after the expiry of the warranty period, it shall be guaranteed for a period equal to the initial warranty period and will be subject to the same conditions.

We recommend for a contract four inspections per year (every three months), before the start of each season, in order to check the operation of the equipment in the various operating modes.

C E R T I F I C A T I O N



N° QUAL/2001/15834c

**LENNOX FRANCE
DIVISION DE LGL FRANCE**

**CONCEPTION, FABRICATION ET CESSION INTERNE
D'UNITES AUTONOMES DE CLIMATISATION DITES "ROOF TOP".**

**DESIGN, MANUFACTURING AND INTERNAL TRANSFER
OF INDEPENDENT AIR CONDITIONING UNITS CALLED "ROOF TOP".**

2, rue Lavoisier ZI de Longvic BP 60 F-21602 LONGVIC CEDEX

AFAQ AFNOR Certification certifie que pour les activités et les sites référencés ci-dessus toutes les dispositions mises en œuvre pour répondre aux exigences requises par la norme internationale :

AFAQ AFNOR Certification certifies that all the arrangements covering the above mentioned activities and locations are established to meet the requirements of the international standard:

ISO 9001 : 2000

*ont été examinées et jugées conformes.
have been examined and found conform.*

2006-01-20

2009-01-23

(année/mois/jour) Il est valable jusqu'au*
It is valid until*

(year/month/day)

Le Directeur Général d'AFAQ AFNOR Certification
The Managing Director of AFAQ AFNOR Certification

J. BESLIN

Le Représentant de l'Entreprise
On Behalf of the Firm

E. MOUTON

*Sauf suspension notifiée entre temps par AFAQ AFNOR Certification à l'entreprise désignée ci-dessus. Le présent document n'a donc qu'une valeur indicative. Seule fait foi la base de données des certificats AFAQ accessible à l'adresse internet : <http://www.afaq.org>. L'organisation AFAQ AFNOR Certification est conforme aux normes internationales en vigueur (guide ISO/IEC 62 - norme EN 45012). AFAQ AFNOR Certification se réserve le droit de modifier, à tout moment et sans préavis la forme de ce document de certification. Ce document, et notamment le logo y figurant, ne peut être utilisé par son titulaire que dans le respect des obligations légales et d'une communication claire et sincère.
*Excepting notification by AFAQ AFNOR Certification to the above-mentioned company of its suspension. This document is for information purposes only. For up-to-date information, the only official source is the AFAQ certificate database at <http://www.afaq.org>. The AFAQ AFNOR Certification organization complies with the international standards in force (62 ISO/IEC Guide - EN 45012 standard). AFAQ AFNOR Certification reserves the right to modify, at anytime and without any tice, the presentation of this certification document. This document and most specifically the logo featuring on this document can only be used by its holder in the frame respecting the legal requirements and a clear and sincere communication.

AFAQ AFNOR CERTIFICATION - BUREAUX : 116, AVENUE ARISTIDE BRIAND - BP 40 / F-92224 BAGNEUX CEDEX - SAS AU CAPITAL DE 18.187.000 EUROS - RCS BOBIGNY B 479 076 002

Les informations contenues dans ce document sont la propriété de AFAQ AFNOR Certification. Toute réimpression ou utilisation non autorisée sans la permission écrite de AFAQ AFNOR Certification est formellement interdite. Toute réimpression ou utilisation non autorisée sans la permission écrite de AFAQ AFNOR Certification est formellement interdite. Information on the accreditation held by AFAQ AFNOR Certification and its subsidiaries is available at <http://www.afaq.org/accreditations>. DGS/01/0485.4 Document contractuel © AFAQ est une marque déposée.

2005/08



Site Industriel de LONGVIC
ZI de LONGVIC – BP 60
21602 LONGVIC – France

Téléphone : +33 (0)3 80 77 41 41
Fax : +33 (0)3 80 66 66 35

Site industriel de MIONS
ZI Les MEURIERES – BP71
69780 MIONS

Téléphone : +33 (0)4 72 23 20 20
Fax : +33 (0) 4 78 20 07 76

**DECLARATION DE CONFORMITE DU CONSTRUCTEUR
Conformément
à la Directive européenne « Equipement sous pression » 97/23/CE,**

**CE CONFORMITY DECLARATION
As defined by
« Pressure equipment » Directive 97/23/EC,**

LGL France SA, ZI Les Meurières – 69780 Mions – France

La société soussignée certifie sous sa seule responsabilité que l'ensemble de nos fabrications de roof top désignés par les types suivants :

The company hereby declare, under its own responsibility, that the entire roof top range which designations are :

**FCK FHK FGK FDK
FXK
FCM FHM FGM FDM
BCK BHK BGK BDK
BAC BAH BAG BAM**

Qui contiennent des fluides frigorigènes classés en groupe 2 (R407C et R410A),
Which are containing refrigerating fluids classified in group 2 (R407C & R410A),

Sont conformes aux dispositions de la Directive « Equipements sous pression », 97/23/CE
Is in compliance with the requirements of « Under pressure equipments » directive, 97/23/EC :

Catégorie *Category* : **II**

Module d'évaluation *Evaluation Module* : **D1**

Organisme notifié *Notified body* : **Bureau VERITAS**

17 bis, place des reflets – La DEFENSE 2 – 92400 Courbevoie.

Sont conformes aux dispositions de la Directive - *Are in compliance with the requirements of*
« Machines », 98/37/CE - « *Machinery* », 98/37/EC
« Basse Tension », 73/23/CEE modifiée - « *Low voltage* », 73/23/EEC amended
« CEM », 2004/108/CEE - « *EMC* », 2004/108/EEC
« Appareils à gaz », 90/396/CEE modifiée - « *Gas machines* », 90/396/EEC amended

Ces produits sont fournis avec un marquage de conformité.
The products are provided with a marking of conformity.

Date : 08/04/08

**V. HEYDECKER
Directeur des sites de Longvic et Mions**



LENNOX France, Division climatisation de LGL France

Siège social : LGL France – ZI « Les Meurières » - BP71 – 69780 MIONS – France

Société anonyme au capital de 309.615.120F – RCS LYON B 309 528 115 – N° IDENTIFICATION TVA FR 59 309 528 115 – APE 292F



Organisme certificateur
 AFAQ AFNOR Certification
 11, rue Francis de Pressensé
 93571 LA PLAINE SAINT-DENIS Cedex
 ☎ : (33) 1.46.11.37.00 - Fax : (33) 1.46.11.39.40
 Site Internet : <http://www.marque-nf.com>

MARQUE NF – SYSTEME DE SECURITE INCENDIE
**CERTIFICAT
 COMPOSANT NF-SSI**



Organisme mandaté
 Comité National Malveillance Incendie Sécurité SAS
 C.N.M.I.S. SAS - 8, Place Boulois - 75017 PARIS
 ☎ : (33) 1.53.89.00.40 - Fax : (33) 1.45.63.40.63
 Site Internet : <http://www.cnmis.org>

<i>Nature et date de la décision</i>
Reconduction du 01/04/2007
N° d'identification : DAD 013 J0

DATE DE FIN DE VALIDITE
31/12/2009

La Société :
FINSECUR
 52 rue Paul LESCOPI

92000 NANTERRE
 France

Correspondant CNMIS SAS José CAMPO : Tél. : 01.53.89.00.48

Pour son usine de :
 NANTERRE - France

est autorisée à apposer la marque NF sur le produit suivant, destiné à être installé dans le(les) SSI certifié(s) NF dont les références commerciales sont listées sur le site Internet www.cnmis.org, selon les conditions définies dans le référentiel de certification NF-SSI :

Désignation normalisée : **Détecteur autonome déclencheur**
 Référence commerciale : **LOTUS I W2C**
 Marque commerciale : **FINSECUR**
 Type : **2 - Non secours**

Ce certificat annule et remplace tout certificat antérieur.

Ce certificat atteste :

- que le produit désigné est certifié conforme à la norme NF S61-961 et spécifications complémentaires telles que spécifiées dans le référentiel de certification NF-SSI ;
- que le produit est associable, en tant que matériel principal, à un Système de Sécurité Incendie certifié NF au sens du référentiel NF-SSI ;
- que le système qualité de la société a été évalué conformément au référentiel de certification NF-SSI.

Il n'engage en aucun cas ni AFAQ AFNOR Certification ni le CNMIS SAS quant à la conformité réglementaire de l'installation dans laquelle le produit objet de ce certificat sera utilisé.

Caractéristiques certifiées :

- Elément sensible : **Non intégré au boîtier**
- Nombre de circuits de détection : **1**
- Nombre de points de détection par circuit : **2**
- Tension de commande nominale : **24 V**
- Puissance maximale de commande : **1 W**
- Divers : **Fonction diagnostic des dysfonctionnements**

Ce certificat NF est valable jusqu'au 31/12/2009 sous réserve des résultats des contrôles effectués par AFAQ AFNOR Certification et le CNMIS SAS qui peuvent prendre toute sanction conformément aux règles générales de la marque NF et au référentiel de certification NF-SSI.

Ce certificat est constitué de 1 page(s).

Pour AFAQ AFNOR Certification,
 le Directeur Général Délégué

Jacques BESLIN

Pour le CNMIS SAS,
 le Président

Denis CLUZEL

LA SECURITE CERTIFIEE



Accréditation
 N° 5-0015
 Portée disponible
 sur www.cofrac.fr

Certificat Certificate



Certificat de conformité à la norme EN 54-7

DETECTEUR OPTIQUE DE FUMEE

Déjà délivré conformément au décret de transposition N°92-647 du 8 juillet 1992, modifié par le décret N° 5-1051 du 20 septembre 1995 concernant l'aptitude à l'usage des produits de construction et à l'article 14 (1) (b) de la Directive Produits de la Construction 89/106/CEE du 21 septembre 1988 amendée par la Directive 93/68/CEE du 22 juillet 1993.

Organisme de certification : **AFAQ AFNOR Certification**
 Numéro d'identification : **0333**
 Adresse : **11, rue Francis de Pressensé
 F 93571 La Plaine Saint-Denis Cedex**

Délivré à :

Société **FINSECUR SA**
 Adresse : **52, rue Paul LESCOP
 92000 NANTERRE - FRANCE**

Lieu de fabrication : **52, rue Paul LESCOP - 92000 NANTERRE - FRANCE**

Description du produit :

Identification du produit certifié (référence)	Désignation du produit selon la norme (classification)	Utilisation Du produit	Numéro de dossier
CAP 100	Détecteur Optique de Fumée	<ul style="list-style-type: none"> - Classe L - Ponctuel - Socle de référence S100 	CE 075-05-066

Le produit mentionné (les produits mentionnés) ci-dessus fait (font) l'objet par le fabricant d'un contrôle de production en usine et à des essais réalisés sur des échantillons prélevés sur le lieu de fabrication conformément à un programme d'essais préétabli,

AFAQ AFNOR Certification a effectué les essais de type initiaux sur ce(s) produit(s), l'inspection initiale du site de production et du contrôle de production en usine et effectue une surveillance continue, une évaluation et une acceptation du contrôle de production en usine.

Ce certificat atteste que les dispositions concernant l'attestation de conformité et les opérations décrites dans l'annexe ZA de la norme EN 54-7 ont été appliquées et que le produit remplit toutes les exigences imposées. Il permet au fabricant ou à son mandataire établi dans l'EEE d'apposer le marquage CE.

Numéro de certificat : 0333 CPD 075 127

Conditions et période de validité du certificat : 30 mars 2011

Ce certificat a été délivré pour la première fois le **31 mars 2006**. Il reste valable jusqu'à son annulation ou son retrait à la suite de décisions prises en cas de non-conformité ou de modifications significatives du produit, de production ou de contrôle de production.

Date d'émission du certificat : le **31 mars 2006**



Le Directeur Général Délégué

Jacques BESLIN
Jacques BESLIN



Siège : 11 avenue Francis de Pressensé - 93571 Saint-Denis La Plaine Cedex - France
 Bureaux : 116 avenue Aristide Briand - BP 40 - 92224 Bagneux Cedex - France
 Tél. : + 33 (0)1 46 11 37 00 - Fax : + 33 (0)1 46 11 39 40
 certification@afaq.afnor.org
 www.afnor.fr - www.marque-nf.com
 SAS au capital de 18 197 000 € - RCS Bobigny B 479 076 002

CSTB

le futur en construction

DEPARTEMENT SECURITE
STRUCTURES ET FEU

Réaction au feu

188

Accréditation
n° 1-0301



**PROCÈS-VERBAL DE CLASSEMENT
DE RÉACTION AU FEU D'UN MATÉRIAU**

Selon l'arrêté du 21 novembre 2002 relatif à la réaction au feu des produits de construction et d'aménagement
Laboratoire pilote agréé du Ministère de l'Intérieur (arrêté du 05/02/59, modifié)

N° RA06-0191

Valable 5 ans à compter du 02 juin 2006

- Matériau présenté par : CAMFIL SAS
Usine de Saint-Martin Longueau
ZI route d'Avrigny
60722 PONT-SAINT-MAXENCE
FRANCE
- Marque commerciale : G 300
- Description sommaire : Media filtrant composé de fibres 100% polyester
non ignifugées.
Epaisseur nominale : 20 mm.
Masse surfacique nominale : 198 g/m².
Coloris : blanc.
- Nature de l'essai : Essai au Brûleur Électrique
Essais Complémentaires

Classement :

M1

Durabilité du classement (Annexe 2 – Paragraphe 5) : Non limitée a priori
compte tenu des critères résultant des essais décrits dans le rapport d'essais N° RA06-0191 annexé.

Ce procès verbal atteste uniquement des caractéristiques de l'échantillon soumis aux essais et ne préjuge pas des caractéristiques de produits similaires. Il ne constitue donc pas une certification de produits au sens de l'article L 115-27 du code de la consommation et de la loi du 3 juin 1994.

Champs-sur-Marne, le 02 juin 2006

Le Technicien Responsable de l'essai

Le Chef du Laboratoire Réaction au Feu

Gildas CREACH

Bruce LE MADEC

Sont seules autorisées les reproductions intégrales du présent procès-verbal de classement ou de l'ensemble procès-verbal de classement et rapport d'essais annexé.

PARIS - MARNE-LA-VALLÉE - GRENOBLE - NANTES - SOPHIA ANTIPOLIS
CENTRE SCIENTIFIQUE ET TECHNIQUE DU BÂTIMENT

84, avenue Jean-Jaurès - Champs-sur-Marne - BP 2 - F-77447 Marne-la-Vallée Cedex 2
Tél. : 01 64 68 84 12 - Fax : 01 64 68 84 79 - E-mail : dssf.cstb.fr



le futur en construction

**DEPARTEMENT SECURITE
STRUCTURES ET FEU**
Réaction au feu

184

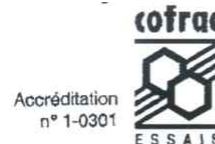

PROCÈS-VERBAL DE CLASSEMENT DE RÉACTION AU FEU D'UN MATÉRIAU

Selon l'arrêté du 21 novembre 2002 relatif à la réaction au feu des produits de construction et d'aménagement
Laboratoire pilote agréé du Ministère de l'Intérieur (arrêté du 05/02/59, modifié)

N° RA05-0065

Valable 5 ans à compter du 17 février 2005

- Matériau présenté par** : HOLLINGSWORTH & VOSE EUROPE
Ikaroslaan 19
1930 ZAVENTEM
BELGIQUE
- Marque commerciale** : A100GN / HF 6165 S
- Description sommaire** : Média filtrant en fibres de verre liées par une résine acrylique.
Masse surfacique nominale : 63 g/m².
Epaisseur nominale : 0,6 mm.
Coloris : blanc.
- Nature de l'essai** : Essai au Brûleur Électrique

Classement : **M1**

Durabilité du classement (Annexe 2 – Paragraphe 5) : Non limitée a priori (média filtrant non régénérable)
compte tenu des critères résultant des essais décrits dans le rapport d'essais N° RA05-0065 annexé.

Ce procès verbal atteste uniquement des caractéristiques de l'échantillon soumis aux essais et ne préjuge pas des caractéristiques de produits similaires. Il ne constitue donc pas une certification de produits au sens de l'article L 115-27 du code de la consommation et de la loi du 3 juin 1994.

Champs-sur-Marne, le 17 février 2005

Le Technicien Responsable de l'essai

Olivier BRAULT

Le Chef du Laboratoire Réaction au Feu

Martial BONHOMME

Sont seules autorisées les reproductions intégrales du présent procès-verbal de classement ou de l'ensemble procès-verbal de classement et rapport d'essais annexé.

PARIS - MARNE-LA-VALLÉE - GRENOBLE - NANTES - SOPHIA ANTIPOLIS
CENTRE SCIENTIFIQUE ET TECHNIQUE DU BÂTIMENT

84, avenue Jean-Jaurès - Champs-sur-Marne - BP 2 - F-77447 Marne-la-Vallée Cedex 2
TÉL : 01 64 68 84 12 - Fax : 01 64 68 84 79 - E-mail : dssi.cstb.fr



DEPARTEMENT SECURITE
STRUCTURES ET FEU
Réaction au feu



PROCÈS-VERBAL DE CLASSEMENT DE RÉACTION AU FEU D'UN MATÉRIAU

Selon l'arrêté du 21 novembre 2002 relatif à la réaction au feu des produits de construction et d'aménagement
Laboratoire pilote agréé du Ministère de l'Intérieur (arrêté du 05/02/59, modifié)

N° RA05-0491

Valable 5 ans à compter du 30 novembre 2005

Matériau présenté par : SAINT GOBAIN ISOVER
18 Avenue d'Alsace
Les Miroirs
92400 COURBEVOIE
FRANCE

Marque commerciale : CLIMAVER 202 - FIB-AIR ISOL

Description sommaire :
Fentre en laine de verre (fibres de verre liées par une résine synthétique thermodurcissable), revêtu sur une face d'une feuille d'aluminium renforcée d'une grille de verre tri directionnelle. Le complexe aluminium est contrecollé à l'aide d'une colle polyéthylène.
Masse volumique nominale de la laine de verre : 30 kg/m³.
Epaisseurs nominales : 25 à 50 mm.
Masse surfacique nominale du complexe : 103 g/m².

Nature de l'essai : Essai par rayonnement avec joint simulé suivant avis CECMI en date du 08 avril 1993.
Mesure du Pouvoir Calorifique Supérieur

Classement :

MO valable pour toute application pour laquelle le produit n'est pas soumis au marquage CE

Durabilité du classement (Annexe 2 – Paragraphe 5) : Non limitée a priori
compte tenu des critères résultant des essais décrits dans le rapport d'essais N° RA05-0491 annexé.

Ce procès verbal atteste uniquement des caractéristiques de l'échantillon soumis aux essais et ne préjuge pas des caractéristiques de produits similaires. Il ne constitue donc pas une certification de produits au sens de l'article L 115-27 du code de la consommation et de la loi du 3 juin 1994.

Champs-sur-Marne, le 30 novembre 2005

Le Technicien Responsable de l'essai

Le Chef du Laboratoire Réaction au Feu

Nicolas ROURE

Martial BONHOMME

Sont seules autorisées les reproductions intégrales du présent procès-verbal de classement ou de l'ensemble procès-verbal de classement et rapport d'essais annexé.

PARIS - MARNE-LA-VALLÉE - GRENOBLE - NANTES - SOPHIA ANTIPOLIS
CENTRE SCIENTIFIQUE ET TECHNIQUE DU BÂTIMENT

84, avenue Jean-Jaurès - Champs-sur-Marne - BP 2 - F-77447 Marne-la-Vallée Cedex 2
Tél. : 01 64 68 84 12 - Fax : 01 64 68 84 70 - E-mail : dsaf.cstb.fr

CSTB

le futur en construction

DEPARTEMENT SECURITE
STRUCTURES ET FEU
Réaction au feu



**PROCES-VERBAL DE CLASSEMENT
DE REACTION AU FEU D'UN MATERIAU**

Selon l'arrêté du 21 novembre 2002 relatif à la réaction au feu des produits de construction et d'aménagement
Laboratoire pilote agréé du Ministère de l'Intérieur (arrêté du 05/02/99, modifié)

N° RA07-0502

Valable 5 ans à compter du 05 décembre 2007

Matériau présenté par : SAINT GOBAIN ISOVER
18 avenue d'Alsace
92400 LA DEFENSE
FRANCE

Marque commerciale : CLIMAVER 274 ou PRIMITIF 2V M0

Description sommaire :
Panneau en laine de verre (fibres de verre liées par une résine synthétique thermodurcissable)
revêtu sur la face apparente d'un voile de verre noir et sur l'autre face d'un voile de verre jaune
renforcé par des fils de verre.
Masses volumiques nominales de la laine de verre : 50 à 62 kg/m³.
Epaisseurs nominales : 25 à 40 mm.
Coloris de la laine de verre : jaune.

Nature de l'essai : Essai par rayonnement
Détermination de la chaleur de combustion (PCS)

Classement : **M0** valable pour toute application pour laquelle le produit n'est pas soumis au marquage CE

Durabilité du classement (Annexe 2 – Paragraphe 5) : Non limitée a priori,
compte tenu des critères résultant des essais décrits dans le rapport d'essais N° RA07-502 annexé.

Ce procès verbal atteste uniquement des caractéristiques de l'échantillon soumis aux essais et ne préjuge pas des caractéristiques de produits similaires. Il ne constitue donc pas une certification de produits au sens de l'article L 113-27 du code de la consommation et de la loi du 3 juin 1994.

Champs-sur-Marne, le 05 décembre 2007

Le Technicien
Responsable de l'essai

David BETTOÏA

Le Responsable de l'activité
Réaction au Feu

Martial BONHOMME

Sont seules autorisées les reproductions intégrales du présent procès-verbal de classement ou de l'ensemble procès-verbal de classement et rapport d'essais annexé.

CENTRE SCIENTIFIQUE ET TECHNIQUE DU BATIMENT

SIÈGE SOCIAL : 84 AVENUE JEAN JAURÈS | CHAMPS-SUR-MARNE | 77447 MARNE-LA-VALLÉE CEDEX 2
TÉL. (33) 01 64 68 84 12 | FAX. (33) 01 64 68 84 79 | www.cstb.fr
MARNE-LA-VALLÉE | PARIS | BRETAGNE | NANTES | SOPHIA-ANTIPOLIS



Certificat
Certificate

(« Gas appliances » 90/396 EEC Directive)
(Directive 90/396/CEE « Appareils à gaz »)

Numéro : 1312B03925 (rév. 4)

CERTIGAZ, after examination and verifications, certifies that the appliance :
CERTIGAZ, après examen et vérifications, certifie que l'appareil :

- **Manufactured by :** **LENNOX FRANCE**
Fabriqué par : **Z.I. LONGVIC - BP 60**
F-21602 LONGVIC CEDEX
- **Trade mark and model(s) :**

LENNOX

Marque commerciale et modèle(s)
 - **BG-B20 – BG-B33 – BG-C20**
 - **BG-C46 – BG-D33 – BG-D60**
 - **BG-E60 – BG-E120**
 - **BG-BM20 – BG-BM33 – BG-CM20 – BG-CM46**
 - **BG-DM33 – BG-DM60 – BG-EM60 – BG-EM120**
- **Kind of the appliance :** **GAS AIR HEATER UNIT FOR ROOF TOP (B22)**
Genre de l'appareil : **MODULE DE CHAUFFAGE POUR CLIMATISEURS DE TOITURE (B22)**
- **Type designation :** **BG-B20**
Désignation du type :

Destination countries <i>Pays de destination</i>	Pressures (mbar) <i>Pressions (mbar)</i>	Categories <i>Catégories</i>
FR	20/25 ; 37	I12Er3P
BE	20/25 ; 37	I2EB ; I3P
PT-CH-ES-GB-CZ-GR-IE	20 ; 37	I12H3P
DE	20 ; 50	I2E ; I3P
DK-SE-IT-CZ-EE-LT-LV	20	I2H
NL	25 ; 37-50	I12L3P
HU	30 ; 50	I3P
CY-MT	50	I3P
SI-SK	20 ; 37 ou 50	I12H3P
PL	20	I2E
PL	36	I3P
SE	37	I3P
CZ	20 ; 37	I12H3P

is in conformity with essential requirements of « Gas appliances » directive 90/396/EEC .
est conforme aux exigences essentielles de la directive "Appareils à gaz" 90/396/CEE.



Paris le : 21/09/2007

CERTIGAZ
Le Directeur Général

Yannick ONFROY
Rév. 4 : 1312B03925 du 2003/07/01

CERTIGAZ SAS - 62 rue de Courcelles - F75008 PARIS - www.certigaz.fr

Bureau Veritas S.A. is a Notified

Body under the number 0062



ATTESTATION D'APPROBATION DE SYSTEME DE QUALITE
CERTIFICATE OF QUALITY SYSTEM APPROVAL

N° CE-PED-D1-LNX 001-05-FRA-revA

BUREAU VERITAS S.A., agissant dans le cadre de sa notification (numéro d'organisme notifié 0062), atteste que le système de qualité appliqué par le fabricant pour l'inspection finale et les essais des équipements sous pression identifiés ci-après, a été examiné selon les prescriptions du module D1 de l'annexe III de la directive "Equipements sous pression" N° 97/23/CE et est conforme aux dispositions correspondantes de la directive.

BUREAU VERITAS S.A., acting within the scope of its notification (notified body number 0062), attests that the quality system operated by the manufacturer for final inspection and testing of the pressure equipment identified hereunder has been examined against the provisions of annex III, module D1, of the Pressure Equipment directive n° 97/23/EC, and found to satisfy the provisions of the directive which apply to it.

Fabricant (Nom) / *Manufacturer (Name)*: **LENNOX France**
 Adresse / *Address*: **2 Rue Lavoisier, 21602 LONGVIC , FRANCE**
 Marque commerciale / *Branding name*: **LENNOX**
 Description des équipements / *Equipment description*: **Climatiseurs de type "ROOFTOP"**
 Identification des équipements concernés (*liste en annexe le cas échéant*) / *Identification of equipment concerned (list attached where necessary)* : **Voir liste en annexe**
Motif de la révision : Extension famille

Cette attestation est valable jusqu'au (MM/JJ/AAAA) / *This certificate is valid until (MM/DD/YYYY)* :
06/13/2008

Le maintien de l'approbation est soumis à la réalisation par le Bureau Veritas des audits, essais et vérifications selon le contrat signé par le fabricant et le Bureau Veritas.

The approval is conditional upon the surveillance audits, tests and verifications to be carried out by Bureau Veritas, as per the provisions stated in the agreement signed by both the manufacturer and Bureau Veritas.

Cette attestation est présumée nulle et le fabricant supportera seul les conséquences de son utilisation, si les assurances - données par le fabricant lors de la demande d'intervention - en matière (a) d'application de son système qualité approuvé, (b) de conformité de son équipement au type et (c) d'inspection et d'essais des produits finis se révèlent inexactes et, de manière générale, si le fabricant ne respecte pas l'une ou l'autre des obligations mises à sa charge par la directive n° 97/23/CE du 29 mai 1997 telle que transposée dans le(s) droit(s) national(aux) applicable(s).

This certificate shall be deemed to be void and the manufacturer shall alone bear any consequences pursuant to its use, where the manufacturer fails to comply with his undertakings as per the agreement in respect of (a) implementation of the approved quality system, (b) conformity of the equipment with the type and (c) inspection and tests on the final product, and generally where the manufacturer fails in particular to comply with any of his obligations under directive nr 97/23/EC of 29 may 1997 as transposed in the applicable law(s).

Etabli à / <i>Made at</i>	Le (MM/JJ/AAAA) / <i>On (MM/DD/YYYY)</i>	Signé par / <i>Signed by</i>	Signature / <i>Signature</i>
DIJON	07/05/2006	Christian Boitelle	
Code d'enregistrement / <i>Registration code</i> : 2006/201.13.12248/P			

La présente attestation est soumise aux Conditions Générales de Service de Bureau Veritas jointes à la demande d'intervention signée par le demandeur. *This certificate is subject to the terms of Bureau Veritas General Conditions of Service attached to the agreement signed by the applicant.*

Bureau Veritas S.A. is a Notified

Body under the number 0062



ANNEXE à l'attestation d'approbation de système de qualité
ANNEX to the certificate of quality system approval

N° CE-PED-D1-LNX 001-05-FRA-revA

Liste des équipements concernés
List of the concerned equipment

Produits standards

Gammes	Modèles
FLEXY:	
FCA, FHA, FGA, FDA,	50 à 200
FCK, FHK, FGK, FDK	50 à 300
FXA, FXK (4 volets)	25 à 200
Flexy (à condensation)	50 à 190
FLEXY 2 (R410 A) :	
FCM, FHM, FGM, FDM	85 à 230
BALTIC:	
Version mono-circuit et bi-circuit,	
BCK, BHK, BGK, BDK	020-025-030-035-040-045-050-060-070



www.lennox europe.com

Due to Lennox's ongoing commitment to quality, the Specifications, Ratings and Dimensions are subject to change without notice and without incurring liability.

Improper installation, adjustment, alteration, service or maintenance can cause property damage or personal injury.

Installation and service must be performed by a qualified installer and servicing agency.



BALTIC R410A-IOM-0708-E