

1 & 2 Livraison en deux parties + casquettes extraction et air neuf fermées
Part 1 & 2 are shipped disassembled + fresh air & extracted air hood closed

3	1	SED21018
2	1	SED21016
1	1	7501761
REP	Nb	DESIGNATION

BALTIC D-BOX

MODULE DE RECUPERATION

LENNOX

"LGL Europe" ZI Les Meurières BP 71 69780 Mions France
Tel : +33 472232020 www.lennox europe.com

TOLERANCE PLIAGE 1/1000 DU FORMAT
BENDING TOLERANCE 1/1000 FORMAT
TOLERANCE DEBIT TUBE 1/100 DU DEBIT
DIMENSIONS TOLERANCE 1/100 OVER ALL DIMENSION

OO N° 2355

HB

07/02/05

3BD30000

☐

Weight : 215.87 Kg

folio : 1 / 2

ACD30000 A2

Modification

Name

Date

Code_ERP

Material

Thickness

Painting

Painting color

Diameter

Tube_cut

Date : 22-Aug-08

Designer : HB

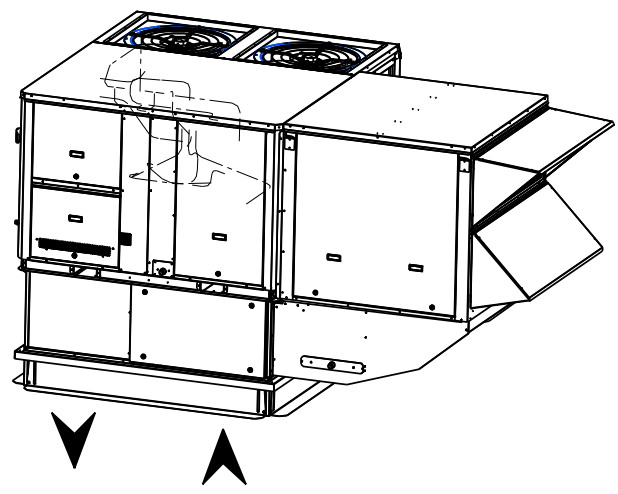
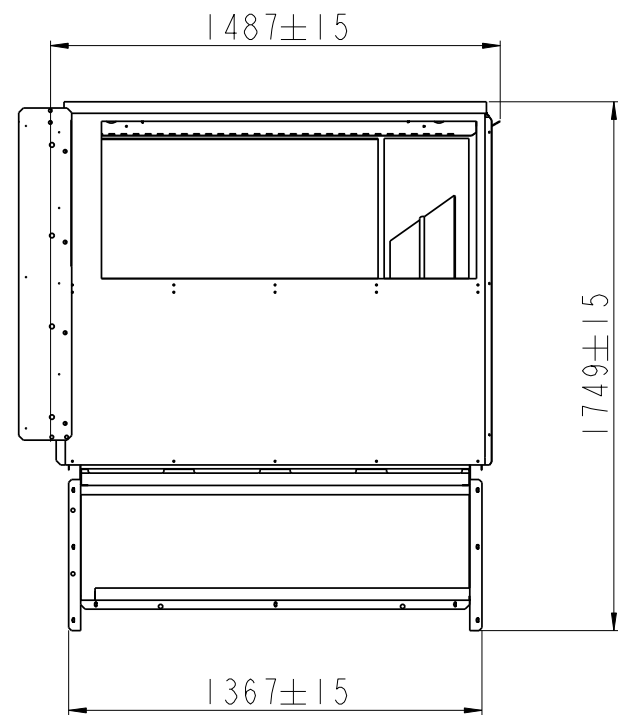
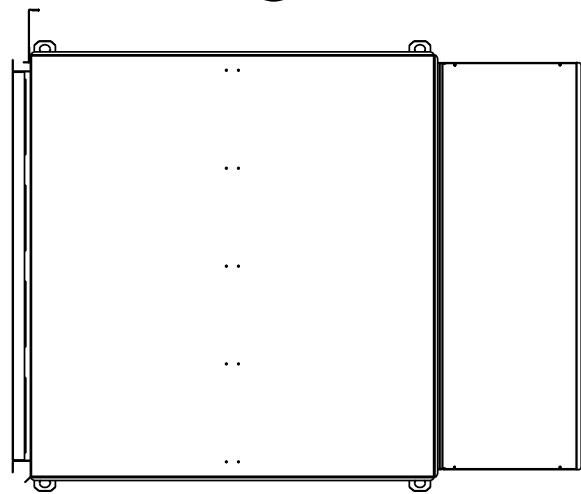
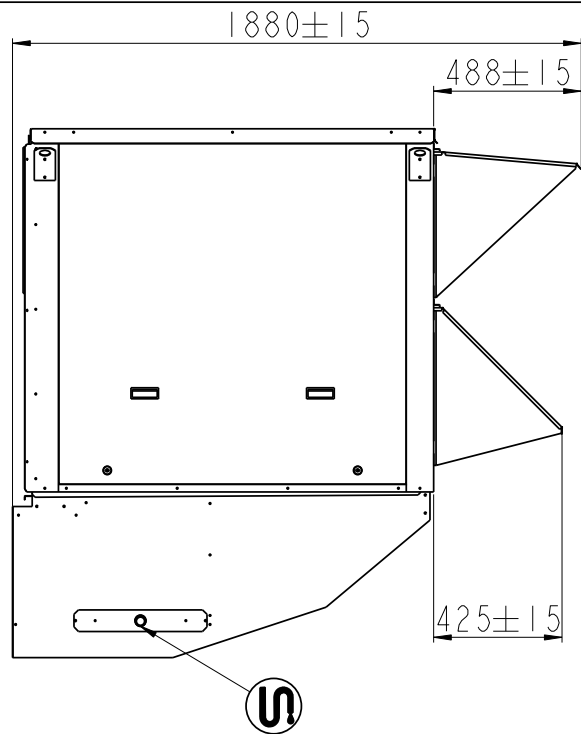

BALTIC D-BOX

MODULE DE RECUPERATION



"LGL Europe" ZI Les Meurières BP 71 69780 Mions France
Tel : +33 472232020 www.lennox europe.com

TOLERANCE PLIAGE 1/1000 DU FORMAT BENDING TOLERANCE 1/1000 FORMAT	QQ N° 2355	HB	07/02/05	38D30000								Weight : 215.87 Kg	folio : 2 / 2	ACD30000 A2
TOLERANCE DEBIT TUBE 1/100 DU DEBIT DIMENSIONS TOLERANCE 1/100 OVER ALL DIMENSION	Modification	Name	Date	Code_ERP	Material	Thickness	Painting	Painting color	Diameter	Tube.cut	Date : 22-Aug-08	Designer : HB		