

# Application guide Installation, operating and maintenance manual

## AQUALEAN

AWC - AWH

Horizontal water cooled packaged  
air conditioner

2 → 20 kW





**WARNING:**

Read this manual before installation, reparation o maintenance works.

<b>Points to bear in mind</b>	<b>2</b>
<b>Data page for commissioning unit</b>	<b>3</b>
<b>1. General characteristics</b>	
1.1 Product range	4
1.2 General description	5
1.3 Physical data	6
1.4 Electrical specifications	6
1.5 Electrical connections	7
1.6 Operating limits	8
1.7 Fan specifications	9
1.8 Capacity tables	10
1.9 Correction factors	15
1.10 Dimensions	16
1.11 Options	18
<b>2. Other functionalities</b>	
<b>21</b>	
<b>3. Installation</b>	
3.1 Pre - installation	22
3.2 Unit installation	23
<b>4. Commissioning and operation</b>	
4.1 Preliminary checks before first installation	25
4.2 Preliminary checks at first installation	25
4.3 Preliminary checks at startup	26
<b>5. Maintenance</b>	
5.1 Preventive maintenance	27
5.2 Corrective maintenance	27

The manufacturing of these units is made under the requirements of the ISO 9001 and ISO 14001.

All the technical and technological information contained in this manual, including any drawing and technical descriptions provided by us, remain the property of Lennox and must not be used (except in the operation of this product), reproduced, issued or made available to third parties without the prior written agreement of Lennox.

## POINTS TO BEAR IN MIND

### DANGER AND WARNING SIGNS



Abrasive surfaces



Low temperatures



High temperatures

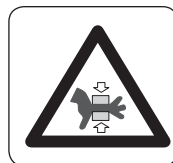

Risk of injury by moving objects

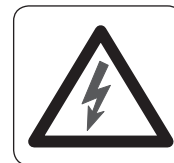

Electrical voltage



Risk of injury by rotating objects

### ELECTRICAL CONNECTIONS



Make sure to switch off the power before installing, repairing or carrying out maintenance on the unit, in order to prevent serious electrical injury.  
Keep local and national legislation in mind when installing the unit.

### ATTENTION - WARNING

Electrical shock hazard can cause injury or death. Before attempting to perform any service or maintenance on the unit, turn OFF the electrical power.  
The air filter cleaning operations do not require technical service; however when an electrical or mechanical operation is required call an Engineer.

### FILTER CLEANING

Check the air filter and make sure it is not blocked with dust or dirt  
If the filter is dirty, wash it in a bowl neutral soap and water, drying it in the shade before inserting it in the unit.

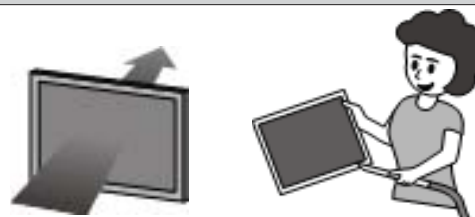

### Standard Guidelines to Lennox equipment

All technical data contained in these operating instructions, including the diagrams and technical description remains the property of Lennox and may not be used (except for the purpose of familiarizing the user with the equipment), reproduced, photocopied, transferred or transmitted to third parties without prior written authorization from Lennox.

The data published in the operating instructions is based on the latest information available. We reserve the right to make modifications without notice.

We reserve the right to modify our products without notice without obligation to modify previously supplied goods.

These operating instructions contain useful and important information for the smooth operation and maintenance of your equipment.

The instructions also include guidelines on how to avoid accidents and serious damage before commissioning the equipment and during its operation and how to ensure smooth and fault-free operation. Read the operating instructions carefully before starting the equipment, familiarize yourself with the equipment and handling of the installation and carefully follow the instructions. It is very important to be properly trained in handling the equipment. These operating instructions must be kept in a safe place near the equipment.

Like most equipment, the unit requires regular maintenance. This section concerns maintenance and management personnel. If you have any queries or would like to receive further information on any aspect relating to your equipment, do not hesitate to contact us.

**DATA PAGE FOR UNIT COMMISSIONING**

Unit :			
Serial nr :			
Control panel identification code :			
Installation address :			
Installer :		Installer phone nr :	
Installer address :			
Date of commissioning :			
<b>Checks :</b>			
Supply voltage :		Rated voltage of the unit :	

	YES	NO
Unit on shock absorbers		
Drainage with trap		
Main power supply connection		
Control panel connection		
Compressor oil level indicator		

**DATA INPUT:**

COOLING CYCLE		HEATING CYCLE	
Air intake temperature to the indoor coil :		Air intake temperature to the indoor coil :	
High pressure :		High pressure:	
Low pressure :		Low pressure:	
<b>ELECTRIC POWER CONSUMPTION (Amps)</b>			
Compressor 1 :		Compressor :	
Indoor fan :		Indoor fan :	

**Options installed :**

---



---



---



---

**Comments :**

---



---



---



---



---

# 1 - GENERAL CHARACTERISTICS

## 1.1. PRODUCT RANGE

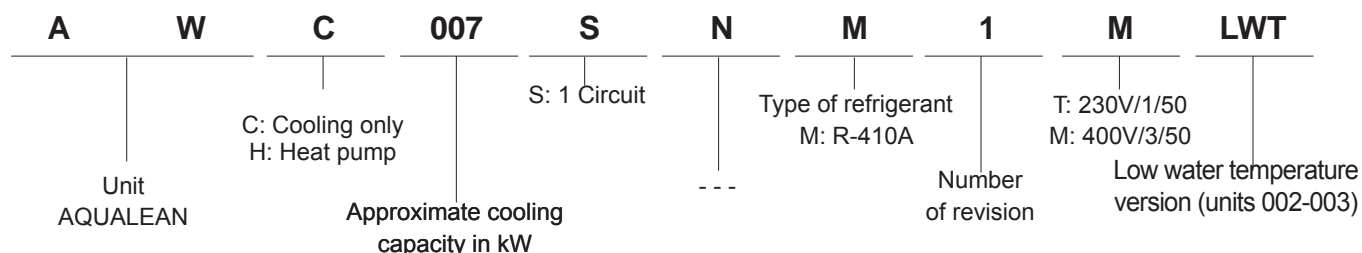

### COOLING ONLY UNITS

MODEL	V / Ph / 50 Hz	NOMINAL CAPACITY kW		NOMINAL POWER INPUT kW	
		COOLING		COOLING	
<b>AWC 007</b>	230 V - 1Ph	6.8		1.7	
<b>AWC 008</b>	230 V - 1Ph	8		2.1	
<b>AWC 010</b>	230 V - 1Ph	10.2		2.6	
<b>AWC 012</b>	230 V - 1Ph	11.2		2.8	
	400 V - 3Ph				
<b>AWC 015</b>	400 V - 3Ph	14.5		3.4	
<b>AWC 018</b>	400V - 3Ph	17		4.2	
<b>AWC 020</b>	400V - 3Ph	19		4.8	

### HEAT PUMP UNITS

MODEL	V / Ph / 50 Hz	NOMINAL CAPACITY kW		NOMINAL POWER INPUT kW	
		COOLING	HEATING	COOLING	HEATING
<b>AWH 002</b>	230 V - 1Ph	2.04	2.6	0.47	0.58
<b>AWH 003</b>	230 V - 1Ph	2.82	3.84	0.62	0.82
<b>AWH 007</b>	230 V - 1Ph	6.8	8	1.7	2.1
<b>AWH 008</b>	230 V - 1Ph	8	9.5	2.1	2.5
<b>AWH 010</b>	230 V - 1Ph	10.2	12.3	2.6	3.2
<b>AWH 012</b>	230 V - 1Ph	11.2		13.5	
	400 V - 3Ph				
<b>AWH 015</b>	400 V - 3Ph	14.5	17	3.4	4.6
<b>AWH 018</b>	400V - 3Ph	17	19.5	4.2	5.1
<b>AWH 020</b>	400V - 3Ph	19	22	4.8	6

AWH 002-003: FAN INCLUDED ONLY IN HEATING MODE

## 1 - GENERAL CHARACTERISTICS

### 1.2. GENERAL DESCRIPTION

The air conditioner, horizontal compact, water condensed type AQUALEAN, are specially designed for small and average installation, office, house, etc.

On standard version the unit cleans, filters, cools and dehumidifies the air (AWC), and in addition heats if it is a heat pump unit (AWH). You are able to incorporate option elements such as electrical heater in units 007 to 020.

#### CASING

Made of unpainted galvanised steel. Thanks to its compact dimensions, can be positioned in almost any location. Thermal-acoustic insulation is installed in compressor area to reduce noise level.

Units 007-020: 25mm A2, s1, d0 (M0) in the air treatment area.

Units 002-003: 10mm (M1) insulation in air section.

#### AIR EXCHANGER

Made of copper tubing with aluminum swirl fins, designed and specially dimensioned to obtain the maximum output.

#### COMPRESSOR

Rotary compressor for units 002-003 and scroll compressor for units 007-020, all of them with internal thermal protection. Mounted on vibration-absorbent blocks both on the inside and outside, statically and dynamically balanced.

#### FAN

In units 002-003 an EC fan motor is installed and in units 007 to 020 there is a centrifugal fan motor with 3 fan speeds management. An automatic mode allows to automatically adapt the airflow rate according to the needs in order to generate energy savings (airflow variation between minimum/nominal/maximum).

#### WATER EXCHANGER

In units 002-003 we have a coaxial exchanger, while in units 007 to 020 we have a plate heat exchanger, compact and resistant, made of brased stainless steel plates and specially selected and designed for this type of unit.

#### COOLING/HEATING CIRCUIT

Manufactured with welded dehumidified copper tubes.

##### Cooling only units (AWC):

Includes a dehydrator filter, a liquid receiver, an electronic expansion valve, as well as a high pressure switch and low pressure transducer.

##### Heat pump units (AWH):

Includes a 4-way valve, and a liquid receiver in the sizes 007 to 020.

**The unit leaves the factory with R410A.**

#### WATER CIRCUIT

It includes water threaded connections H-G.

#### AIR FILTER

Washable polypropylene air filter. Filter installed on a rail for an easy maintenance.

#### ELECTRICAL BOARD

The electrical box includes all the components and the main terminal blocks. It includes a printed board, a 4-way valve, alarms, remote control and a 230V-1 Amp electrical connection for a circulation water pump.

#### REMOTE CONTROL

The unit can be delivered with a customer display offering the following functionalities:

- On/Off
- Operating mode selection (Cooling/Heating/Auto)
- Room temperature setpoint setting
- Airflow rate setting (Mini/Nominal/Max/Auto)
- Supervision of up to 10 units connected in Master/Slave. A DS60 is required to enable this function in the DC60 (Expert Menu). Plan to commission the units with a Lennox certified technician.
- Time setting
- Ambience temperature reading
- Alarm codes reading.

A duct sensor is included as standard, but an ambient sensor can be installed as a special option. DC 60 includes an ambient sensor, but must be configured in the start up with a DS60. By default, the temperature measurement is done through the duct sensor.



**DC60**

Optional in units 002 and 003.  
Standard in units 007 to 020.



**DM60**

Optional in all units.

#### OPTIONS

##### For units 002 to 020:

- ModBus/BACnet/LonWorks Interface.
- DM60 display for scheduling/zoning settings.
- DS60 service display.

##### For units 007 to 020:

- Electrical heater mounted on fan discharge.
- Paddle flow switch.
- Water filter.
- Main disconnect switch.
- Compressor acoustic insulation.
- Low water loop temperature.
- Water differential pressure switch.

##### For units 012 to 020:

- Phase protection (3-phase units).

# 1 - GENERAL CHARACTERISTICS

## 1.3.- PHYSICAL DATA

UNIT MODEL		AWH 002	AWH 003	AWC 007 AWH 007	AWC 008 AWH 008	AWC 010 AWH 010	AWC 012 AWH 012	AWC 015 AWH 015	AWC 018 AWH 018	AWC 020 AWH 020	
Total cooling capacity	kW (*)	2.04	2.82	6.8	8.0	10.2	11.2	14.5	17.0	19.0	
Total heating capacity	kW (**)	2.6	3.84	8.0	9.5	12.3	13.5	17.0	19.5	22.0	
Nominal absorbed power Cooling	kW (*)	0.47	0.62	1.7	2.1	2.6	2.8	3.4	4.2	4.8	
Nominal absorbed power Heating	kW (**)	0.58	0.82	2.1	2.5	3.2	3.6	4.6	5.1	6.0	
Air flow (max./min.)	m³/h	465/285	550/335	1430/1010	1620/1250	2100/1550	2200/1620	2610/1850	3100/2060	3500/2450	
Max. available static pressure(1)	Pa	90	100	150	125	150	150	150	150	150	
Nominal water flow	l/h	480	560	1450	1730	2190	2410	3070	3640	4090	
Water pressure drop	kPa	19	24	25	30	40	48	40	45	55	
Net weight Cooling / heating	Kg	53	56	69/71	70/72	109/111	111/113	113/116	148/151	148/151	
Sound pressure level (LP) (2)	Low/High speed	dB(A)	41/43	43/46	49/51	50/52	48/51	49/51	49/53	46/51	47/54
	Height	mm	230	230	441	441	491	491	491	531	531
	Width	mm	1000	1000	886	886	1180	1180	1180	1600	1600
Dimensions	Depth	mm	500	500	492	492	623	623	623	703	703
Hydraulic connections		1/2" G	1/2" G	1" G	1" G	1" G	1" G	1" G	1" G	1" G	
Refrigerant load		0.6	0.7	1.3	1.3	1.85	1.9	2.4	2.9	2.9	

(\*) Exchanger air inlet temperature: 27°C DB / 19°C WB.  
Exchanger water inlet temperature: 30°C.

(\*\*) Exchanger air inlet temperature: 20°C DB.  
Exchanger water inlet temperature: 20°C.

(1) With admissible minimum air flow.

(2) Sound pressure level has been tested at a distance of 2 m from the unit, with duct in aspiration and air discharge, normal absorption in accordance with room size and unit capacity.

DB.- Dry bulb temperature  
WB.- Wet bulb temperature

## 1.4.- ELECTRICAL SPECIFICATIONS

UNIT MODEL		AWH 002	AWH 003	AWC 007 AWH 007	AWC 008 AWH 008	AWC 010 AWH 010	AWC 012 AWH 012	AWC 015 AWH 015	AWC 018 AWH 018	AWC 020 AWH 020
VOLTAGE		230V/1Ph	230V/1Ph	230V/1Ph	230V/1Ph	230V/1Ph	230V/1Ph	-	-	-
		-	-	-	-	-	400V 3Ph	400V 3Ph	400V 3Ph	400V 3Ph
MAXIMUM AB-SORBED POWER	Compressor	0.67	0.817	2.57	3.15	3.82	4.62 / 4.31	5.46	5.93	7.26
	Indoor fan	0.055	0.100	0.147	0.147	0.25	0.25	0.25	0.315	0.315
	TOTAL	0.725	0.917	2.72	3.3	4.07	4.87 / 4.56	5.71	6.25	7.58
MAXIMUM RUNNING CURRENT	Maximum running current	3.6	4.9	14.4	17.6	24.6	28.6 / 10.6	12.9	14.7	17.9
	Starting current	15.3	17.3	61.6	68.6	100.6	130.6 / 45.6	54.1	66.9	77.9



# 1 - GENERAL CHARACTERISTICS

## 1.5.- ELECTRICAL CONNECTIONS.

- 1 Power supply
- 2 Power supply with electrical heater (units 007 to 020).
- 3 Connection control.

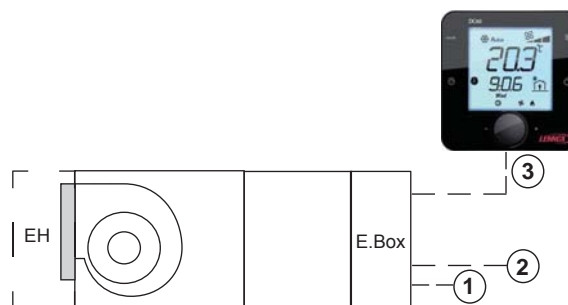

FOR ELECTRICAL CONNECTION REFER TO WIRING DIAGRAM IN THE UNIT.

MODEL	VOLTAGE 50Hz	WIRE NUMBER AND SECTION		
		1	2	3
AWH 002	230V / 1Ph	3 X 1,5 mm <sup>2</sup>	-	5 X 1 mm <sup>2</sup> shielded
AWH 003	230V / 1Ph	3 X 1,5 mm <sup>2</sup>	-	
AWC/H 007	230V / 1Ph	3 X 2,5mm <sup>2</sup>	3 X 10mm <sup>2</sup>	
AWC/H 008	230V / 1Ph	3 X 2,5mm <sup>2</sup>	3 X 10mm <sup>2</sup>	
AWC/H 010	230V / 1Ph	3 X 6mm <sup>2</sup>	3 X 16mm <sup>2</sup>	
AWC/H 012	230V / 1Ph	3 X 6mm <sup>2</sup>	3 X 16mm <sup>2</sup>	
	400V / 3Ph+N	5 X 2,5mm <sup>2</sup>	5 X 6mm <sup>2</sup>	
AWC/H 015	400V / 3Ph+N	5 X 2,5mm <sup>2</sup>	5 X 6mm <sup>2</sup>	
AWC/H 018	400V / 3Ph+N	5 X 4mm <sup>2</sup>	5 X 10mm <sup>2</sup>	
AWC/H 020	400V / 3Ph+N	5 X 4mm <sup>2</sup>	5 X 10mm <sup>2</sup>	



Local and national legislation has to be taken into account when the unit will be installed.



### INSTALLATION GUIDE FOR CONTROL CABLE (TO AVOID INTERFERENCES):

- Use the screened 15 m cable supplied with terminal (3 wires + screen).
  - Wire the cable separated from electrical power wiring by a physical distance of 500 mm.
  - Wire the cable separated from halogen lamps/fluorescent tube lighting... by a physical distance of 500 mm.
  - Wire the cable separated from radio frequency sources such as radio transmitter... at least 500 mm.
- NEVER WIND THE REMAINING CABLE AROUND, CUT THE CABLE BY THE TERMINAL END.

# 1 - GENERAL CHARACTERISTICS

## 1.6.1.- OPERATING LIMITS.

### AWH 002-020 STANDARD UNIT VERSION.

#### COOLING MODE

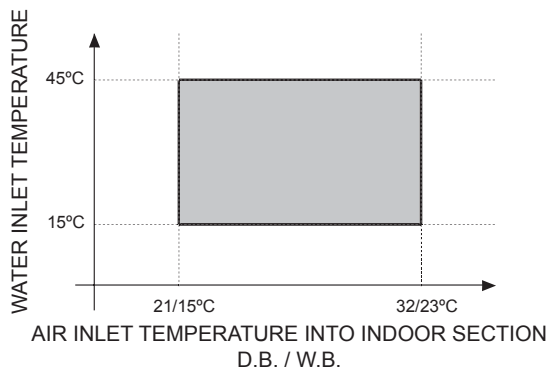

#### HEATING MODE

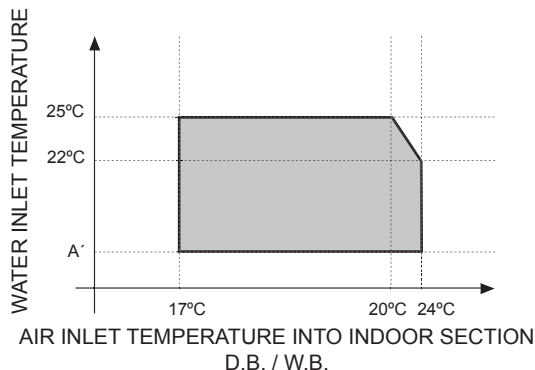

	002-003	007-020
A'	15°C	10°C

WB - Wet bulb temperature  
DB - Dry bulb temperature

**AWH 002-003 LWT VERSION:** it includes water regulation valve + high pressure transducer + piping insulation.

#### COOLING MODE

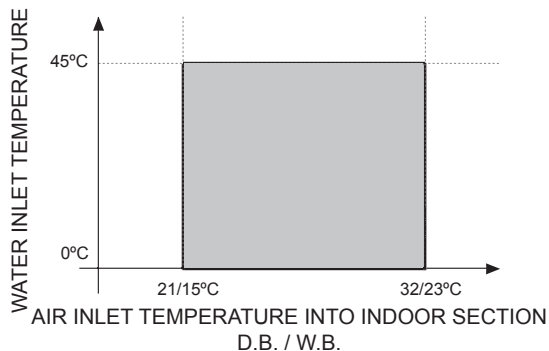

#### HEATING MODE

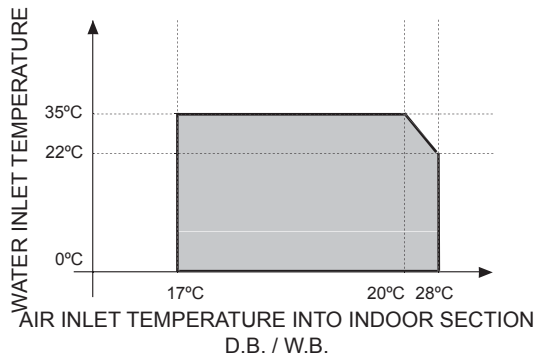

NOTE: Operation with water outlet temperature below +5°C requires anti-freeze solution.

WB - Wet bulb temperature  
DB - Dry bulb temperature

**AWC/H 007-020:** it includes water regulation valve + high pressure transducer.

#### COOLING MODE

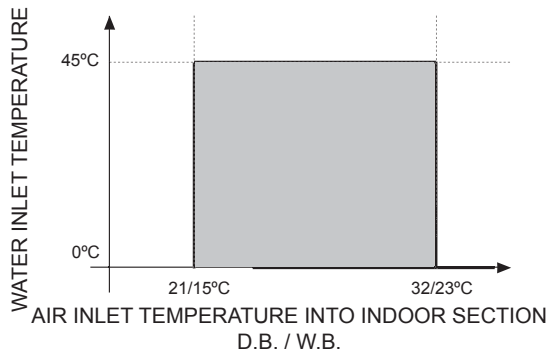

#### HEATING MODE

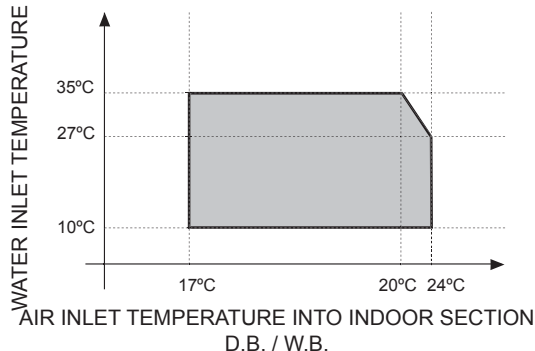

WB - Wet bulb temperature  
DB - Dry bulb temperature

# 1 - GENERAL CHARACTERISTICS

## 1.7.- FAN SPECIFICATIONS

AWH 002		AVAILABLE STATIC PRESSURE Pa.						
		25	35	50	65	80	90	100
AIR FLOW m <sup>3</sup> /h	HIGH SPEED	465	450	395	340	305	285	-
	MEDIUM SPEED	430	390	330	285	-	-	-
	LOW SPEED	385	345	285	-	-	-	-

AWH 003		AVAILABLE STATIC PRESSURE Pa.						
		25	35	50	65	80	90	100
AIR FLOW m <sup>3</sup> /h	HIGH SPEED	550	520	480	435	385	355	335
	MEDIUM SPEED	445	415	365	335	-	-	-
	LOW SPEED	410	380	335	-	-	-	-

AWH/C 007		AVAILABLE STATIC PRESSURE Pa.						
		25	37	50	75	100	125	150
AIR FLOW m <sup>3</sup> /h	HIGH SPEED	1430	1400	1375	1315	1245	1165	1065
	MEDIUM SPEED	1300	1250	1240	1185	1125	1050	-
	LOW SPEED	1170	1140	1125	1070	1010	-	-

AWH/C 008		AVAILABLE STATIC PRESSURE Pa.						
		25	37	50	75	100	125	150
AIR FLOW m <sup>3</sup> /h	HIGH SPEED	1620	1585	1550	1475	1395	1300	-
	MEDIUM SPEED	1550	1500	1480	1420	1350	1260	-
	LOW SPEED	1430	1400	1375	1315	1250	-	-

AWH/C 010		AVAILABLE STATIC PRESSURE Pa.						
		25	37	50	75	100	125	150
AIR FLOW m <sup>3</sup> /h	HIGH SPEED	2100	2075	2050	1990	1925	1850	1750
	MEDIUM SPEED	1915	1900	1885	1830	1790	1700	-
	LOW SPEED	1685	1680	1675	1640	1600	1550	-

AWH/C 012		AVAILABLE STATIC PRESSURE Pa.						
		25	37	50	75	100	125	150
AIR FLOW m <sup>3</sup> /h	HIGH SPEED	2200	2180	2150	2025	1925	1800	1550
	MEDIUM SPEED	2025	2000	1985	1875	1775	1650	-
	LOW SPEED	1825	1815	1780	1700	1620	-	-

AWH/C 015		AVAILABLE STATIC PRESSURE Pa.						
		25	37	50	75	100	125	150
AIR FLOW m <sup>3</sup> /h	HIGH SPEED	2610	2550	2480	2350	2185	2000	1750
	MEDIUM SPEED	2575	2560	2450	2300	2150	1970	1730
	LOW SPEED	2350	2300	2250	2150	2025	1850	-

AWH/C 018		AVAILABLE STATIC PRESSURE Pa.						
		25	37	50	75	100	125	150
AIR FLOW m <sup>3</sup> /h	HIGH SPEED	3100	2980	2960	2815	2650	2450	2210
	MEDIUM SPEED	2910	2850	2800	2610	2450	2300	2100
	LOW SPEED	2615	2550	2500	2375	2230	2060	-

AWH/C 020		AVAILABLE STATIC PRESSURE Pa.						
		25	37	50	75	100	125	150
AIR FLOW m <sup>3</sup> /h	HIGH SPEED	3500	3400	3300	3100	2900	2600	2300
	MEDIUM SPEED	3250	3200	3100	2940	2750	2550	2300
	LOW SPEED	3100	3030	2960	2815	2650	2450	-

# 1 - GENERAL CHARACTERISTICS

## 1.8.- CAPACITY TABLES

### AWH 002 Nominal air flow 465 m<sup>3</sup>/h

Water inlet temperature °C	Water flow l/h		Water pressure drop kPa	COOLING CAPACITY AWC/AWH			HEATING CAPACITY AWH	
				Total capacity kW	EER	Sensible/Total	Total capacity kW	COP
10	Minimum	280	10.0	---	---	---	2.08	3.94
	Nominal	480	19.0	---	---	---	2.13	3.98
	Maximum	700	39.0	---	---	---	2.18	3.99
15	Minimum	280	10.0	2.26	7.00	0.70	2.30	4.21
	Nominal	480	19.0	2.31	8.09	0.70	2.37	4.26
	Maximum	700	39.0	2.34	9.00	0.69	2.43	4.26
20	Minimum	280	10.0	2.18	5.59	0.71	2.54	4.43
	Nominal	480	19.0	2.22	6.21	0.71	2.60	4.47
	Maximum	700	39.0	2.25	6.71	0.70	2.66	4.49
25	Minimum	280	10.0	2.09	4.66	0.72	2.77	4.66
	Nominal	480	19.0	2.13	5.08	0.72	2.81	4.67
	Maximum	700	39.0	2.16	5.40	0.71	2.89	4.67
30	Minimum	280	10.0	2.00	3.97	0.74	2.91	4.79
	Nominal	480	19.0	2.04	4.29	0.73	2.99	4.81
	Maximum	700	39.0	2.07	4.52	0.73	3.07	4.83
35	Minimum	280	10.0	1.89	3.40	0.76	3.08	4.90
	Nominal	480	19.0	1.95	3.67	0.75	3.17	4.91
	Maximum	700	39.0	1.98	3.84	0.74	3.25	4.93
40	Minimum	280	10.0	1.78	2.91	0.78	---	---
	Nominal	480	19.0	1.84	3.14	0.76	---	---
	Maximum	700	39.0	1.87	3.28	0.76	---	---

### AWH 003 Nominal air flow 550 m<sup>3</sup>/h

Water inlet temperature °C	Water flow l/h		Water pressure drop kPa	COOLING CAPACITY AWC/AWH			HEATING CAPACITY AWH	
				Total capacity kW	EER	Sensible/Total	Total capacity kW	COP
10	Minimum	390	16.0	---	---	---	3.03	3.98
	Nominal	560	24.0	---	---	---	3.09	4.08
	Maximum	800	41.0	---	---	---	3.18	4.14
15	Minimum	390	16.0	3.14	6.48	0.70	3.41	4.26
	Nominal	560	24.0	3.22	7.22	0.70	3.48	4.35
	Maximum	800	41.0	3.28	7.77	0.69	3.50	4.44
20	Minimum	390	16.0	3.01	5.55	0.72	3.68	4.56
	Nominal	560	24.0	3.09	6.12	0.71	3.84	4.65
	Maximum	800	41.0	3.15	6.53	0.70	3.86	4.71
25	Minimum	390	16.0	2.87	4.80	0.73	4.14	4.71
	Nominal	560	24.0	2.96	5.25	0.72	4.22	4.74
	Maximum	800	41.0	3.01	5.57	0.72	4.29	4.75
30	Minimum	390	16.0	2.73	4.16	0.75	4.41	4.78
	Nominal	560	24.0	2.82	4.53	0.74	4.45	4.80
	Maximum	800	41.0	2.87	4.79	0.73	4.48	4.83
35	Minimum	390	16.0	2.59	3.60	0.76	4.59	4.82
	Nominal	560	24.0	2.67	3.92	0.75	4.63	4.84
	Maximum	800	41.0	2.73	4.14	0.75	4.66	4.85
40	Minimum	390	16.0	2.44	3.10	0.79	---	---
	Nominal	560	24.0	2.52	3.38	0.77	---	---
	Maximum	800	41.0	2.58	3.57	0.77	---	---

Nominal capacity conditions : Exchanger air inlet temperature: 27°C DB/19°C WB for cooling & 20°C WB for heating mode.

(DW:dry bulb / WB:wet bulb)

For another working conditions use correction factor tables.

**AWH 002-003: FAN INCLUDED ONLY IN HEATING MODE**

# 1 - GENERAL CHARACTERISTICS

## 1.8.- CAPACITY TABLES

### AWC/AWH 007 Nominal air flow 1.250 m<sup>3</sup>/h

Water inlet temperature °C	Water flow l/h		Water pressure drop kPa	COOLING CAPACITY AWC/AWH			HEATING CAPACITY AWH	
				Total capacity kW	EER	Sensible/Total	Total capacity kW	COP
10	Minimum	1010	15	---	---	---	6,28	3,43
	Nominal	1450	25	---	---	---	6,49	3,48
	Maximum	2070	40	---	---	---	6,62	3,52
15	Minimum	1010	15	7,43	6,27	0,66	7,03	3,62
	Nominal	1450	25	7,51	6,56	0,66	7,24	3,67
	Maximum	2070	40	7,55	6,83	0,66	7,40	3,70
20	Minimum	1010	15	7,20	5,31	0,67	7,77	3,76
	Nominal	1450	25	7,28	5,57	0,66	8,00	3,80
	Maximum	2070	40	7,33	5,80	0,66	8,17	3,82
25	Minimum	1010	15	6,94	4,49	0,68	8,51	3,85
	Nominal	1450	25	7,03	4,72	0,67	8,75	3,88
	Maximum	2070	40	7,08	4,91	0,67	8,95	3,89
30	Minimum	1010	15	6,66	3,80	0,69	---	---
	Nominal	1450	25	6,75	4,00	0,68	---	---
	Maximum	2070	40	6,81	4,14	0,68	---	---
35	Minimum	1010	15	6,36	3,25	0,70	---	---
	Nominal	1450	25	6,45	3,41	0,69	---	---
	Maximum	2070	40	6,51	3,52	0,69	---	---
40	Minimum	1010	15	6,04	2,82	0,71	---	---
	Nominal	1450	25	6,13	2,96	0,71	---	---
	Maximum	2070	40	6,20	3,02	0,70	---	---

### AWC/AWH 008 Nominal air flow 1.500 m<sup>3</sup>/h

Water inlet temperature °C	Water flow l/h		Water pressure drop kPa	COOLING CAPACITY AWC/AWH			HEATING CAPACITY AWH	
				Total capacity kW	EER	Sensible/Total	Total capacity kW	COP
10	Minimum	1210	20	---	---	---	7,56	3,43
	Nominal	1730	30	---	---	---	7,79	3,47
	Maximum	2470	50	---	---	---	7,93	3,51
15	Minimum	1210	20	8,85	5,86	0,66	8,41	3,59
	Nominal	1730	30	8,95	6,09	0,65	8,65	3,63
	Maximum	2470	50	9,01	6,30	0,65	8,81	3,66
20	Minimum	1210	20	8,55	5,05	0,66	9,25	3,72
	Nominal	1730	30	8,65	5,26	0,66	9,50	3,75
	Maximum	2470	50	8,71	5,45	0,66	9,68	3,77
25	Minimum	1210	20	8,23	4,34	0,67	10,08	3,79
	Nominal	1730	30	8,33	4,54	0,67	10,34	3,82
	Maximum	2470	50	8,40	4,69	0,67	10,55	3,83
30	Minimum	1210	20	7,90	3,73	0,68	---	---
	Nominal	1730	30	8,00	3,90	0,68	---	---
	Maximum	2470	50	8,07	4,03	0,68	---	---
35	Minimum	1210	20	7,55	3,21	0,69	---	---
	Nominal	1730	30	7,65	3,36	0,69	---	---
	Maximum	2470	50	7,73	3,46	0,69	---	---
40	Minimum	1210	20	7,18	2,78	0,70	---	---
	Nominal	1730	30	7,29	2,91	0,70	---	---
	Maximum	2470	50	7,37	2,98	0,70	---	---

Nominal capacity conditions : Exchanger air inlet temperature: 27°C DB/19°C WB for cooling & 20°C WB for heating mode.

(DW:dry bulb / WB:wet bulb)

For another working conditions use correction factor tables.

# 1 - GENERAL CHARACTERISTICS

## 1.8.- CAPACITY TABLES

### AWC/AWH 010 Nominal air flow 1.900 m<sup>3</sup>/h

Water inlet temperature °C	Water flow l/h		Water pressure drop kPa	COOLING CAPACITY AWC/AWH			HEATING CAPACITY AWH	
				Total capacity kW	EER	Sensible/ Total	Total capacity kW	COP
10	Minimum	1530	25	---	---	---	9,77	3,56
	Nominal	2190	40	---	---	---	10,06	3,60
	Maximum	3130	65	---	---	---	10,24	3,64
15	Minimum	1530	25	11,19	6,05	0,68	10,85	3,73
	Nominal	2190	40	11,30	6,29	0,67	11,17	3,77
	Maximum	3130	65	11,37	6,53	0,67	11,39	3,80
20	Minimum	1530	25	10,85	5,20	0,68	11,96	3,86
	Nominal	2190	40	10,97	5,42	0,68	12,30	3,90
	Maximum	3130	65	11,04	5,62	0,68	12,55	3,92
25	Minimum	1530	25	10,48	4,46	0,69	13,10	3,96
	Nominal	2190	40	10,60	4,66	0,69	13,46	3,99
	Maximum	3130	65	10,68	4,83	0,69	13,75	4,01
30	Minimum	1530	25	10,07	3,83	0,70	---	---
	Nominal	2190	40	10,20	4,00	0,70	---	---
	Maximum	3130	65	10,29	4,14	0,70	---	---
35	Minimum	1530	25	9,63	3,30	0,72	---	---
	Nominal	2190	40	9,76	3,45	0,71	---	---
	Maximum	3130	65	9,86	3,56	0,71	---	---
40	Minimum	1530	25	9,15	2,89	0,73	---	---
	Nominal	2190	40	9,29	3,01	0,73	---	---
	Maximum	3130	65	9,39	3,09	0,72	---	---

### AWC/AWH 012 Nominal air flow 2.000 m<sup>3</sup>/h

Water inlet temperature °C	Water flow l/h		Water pressure drop kPa	COOLING CAPACITY AWC/AWH			HEATING CAPACITY AWH	
				Total capacity kW	EER	Sensible/ Total	Total capacity kW	COP
10	Minimum	1690	30	---	---	---	10,74	3,52
	Nominal	2410	48	---	---	---	11,05	3,56
	Maximum	3440	75	---	---	---	11,25	3,59
15	Minimum	1690	30	12,37	6,05	0,66	11,94	3,67
	Nominal	2410	48	12,50	6,29	0,66	12,26	3,70
	Maximum	3440	75	12,59	6,50	0,66	12,50	3,72
20	Minimum	1690	30	11,96	5,20	0,67	13,15	3,77
	Nominal	2410	48	12,10	5,42	0,67	13,50	3,80
	Maximum	3440	75	12,18	5,61	0,67	13,77	3,81
25	Minimum	1690	30	11,52	4,46	0,68	14,38	3,84
	Nominal	2410	48	11,66	4,66	0,68	14,75	3,86
	Maximum	3440	75	11,75	4,82	0,67	15,05	3,87
30	Minimum	1690	30	11,06	3,83	0,69	---	---
	Nominal	2410	48	11,20	4,00	0,68	---	---
	Maximum	3440	75	11,30	4,13	0,68	---	---
35	Minimum	1690	30	10,57	3,29	0,70	---	---
	Nominal	2410	48	10,71	3,45	0,70	---	---
	Maximum	3440	75	10,82	3,55	0,69	---	---
40	Minimum	1690	30	10,06	2,87	0,71	---	---
	Nominal	2410	48	10,20	3,00	0,71	---	---
	Maximum	3440	75	10,31	3,07	0,71	---	---

Nominal capacity conditions: Exchanger air inlet temperature: 27°C DB/19°C WB for cooling y 20°C WB for heating mode.  
(DW:dry bulb WB:wet bulb)

For another working conditions use correction factor tables.

# 1 - GENERAL CHARACTERISTICS

## 1.8.- CAPACITY TABLES

### AWC/AWH 015 Nominal air flow 2.450 m<sup>3</sup>/h

Water inlet temperature °C	Water flow l/h		Water pressure drop kPa	COOLING CAPACITY AWC/AWH			HEATING CAPACITY AWH	
				Total capacity kW	EER	Sensible/ Total	Total capacity kW	COP
10	Minimum	2150	25	---	---	---	13,59	3,39
	Nominal	3070	40	---	---	---	13,99	3,43
	Maximum	4390	60	---	---	---	14,26	3,46
15	Minimum	2150	25	16,02	6,41	0,67	15,06	3,54
	Nominal	3070	40	16,20	6,67	0,67	15,49	3,58
	Maximum	4390	60	16,31	6,89	0,67	15,80	3,61
20	Minimum	2150	25	15,49	5,56	0,68	16,54	3,66
	Nominal	3070	40	15,67	5,79	0,67	17,00	3,70
	Maximum	4390	60	15,79	5,98	0,67	17,35	3,72
25	Minimum	2150	25	14,92	4,79	0,68	18,04	3,76
	Nominal	3070	40	15,10	5,00	0,68	18,52	3,79
	Maximum	4390	60	15,23	5,17	0,68	18,92	3,81
30	Minimum	2150	25	14,32	4,11	0,70	---	---
	Nominal	3070	40	14,50	4,30	0,69	---	---
	Maximum	4390	60	14,63	4,44	0,69	---	---
35	Minimum	2150	25	13,68	3,51	0,71	---	---
	Nominal	3070	40	13,87	3,69	0,70	---	---
	Maximum	4390	60	14,00	3,80	0,70	---	---
40	Minimum	2150	25	13,01	3,01	0,72	---	---
	Nominal	3070	40	13,20	3,17	0,72	---	---
	Maximum	4390	60	13,34	3,26	0,71	---	---

### AWC/AWH 018 Nominal air flow 2.800 m<sup>3</sup>/h

Water inlet temperature °C	Water flow l/h		Water pressure drop kPa	COOLING CAPACITY AWC/AWH			HEATING CAPACITY AWH	
				Total capacity kW	EER	Sensible/ Total	Total capacity kW	COP
10	Minimum	2540	30	---	---	---	15,55	3,36
	Nominal	3640	45	---	---	---	16,00	3,42
	Maximum	5200	70	---	---	---	16,28	3,45
15	Minimum	2540	30	18,55	5,86	0,66	17,25	3,56
	Nominal	3640	45	18,72	6,07	0,66	17,73	3,62
	Maximum	5200	70	18,81	6,25	0,66	18,07	3,65
20	Minimum	2540	30	18,03	5,15	0,67	18,98	3,75
	Nominal	3640	45	18,21	5,34	0,66	19,50	3,80
	Maximum	5200	70	18,31	5,50	0,66	19,89	3,84
25	Minimum	2540	30	17,44	4,51	0,67	20,74	3,91
	Nominal	3640	45	17,63	4,69	0,67	21,30	3,96
	Maximum	5200	70	17,75	4,83	0,67	21,75	4,00
30	Minimum	2540	30	16,80	3,93	0,68	---	---
	Nominal	3640	45	17,00	4,10	0,68	---	---
	Maximum	5200	70	17,14	4,22	0,68	---	---
35	Minimum	2540	30	16,09	3,43	0,69	---	---
	Nominal	3640	45	16,31	3,58	0,69	---	---
	Maximum	5200	70	16,46	3,68	0,69	---	---
40	Minimum	2540	30	15,33	3,00	0,70	---	---
	Nominal	3640	45	15,55	3,13	0,70	---	---
	Maximum	5200	70	15,72	3,21	0,70	---	---

Nominal capacity conditions: Exchanger air inlet temperature: 27°C DB/19°C WB for cooling y 20°C WB for heating mode.  
(DW:dry bulb WB:wet bulb)

For another working conditions use correction factor tables.

# 1 - GENERAL CHARACTERISTICS

## 1.8.- CAPACITY TABLES

### AWC/AWH 020 Nominal air flow 3.100 m<sup>3</sup>/h

Water inlet temperature °C	Water flow l/h		Water pressure drop kPa	COOLING CAPACITY AWC/AWH			HEATING CAPACITY AWH	
				Total capacity kW	EER	Sensible/Total	Total capacity kW	COP
10	Minimum	2860	35	---	---	---	17,65	3,43
	Nominal	4090	55	---	---	---	18,13	3,46
	Maximum	5840	80	---	---	---	18,45	3,48
15	Minimum	2860	35	20,89	5,68	0,65	19,53	3,54
	Nominal	4090	55	21,12	5,88	0,65	20,06	3,57
	Maximum	5840	80	21,25	6,04	0,65	20,42	3,58
20	Minimum	2860	35	20,23	5,01	0,66	21,44	3,63
	Nominal	4090	55	20,46	5,20	0,66	22,00	3,65
	Maximum	5840	80	20,60	5,34	0,66	22,42	3,66
25	Minimum	2860	35	19,52	4,40	0,67	23,37	3,69
	Nominal	4090	55	19,75	4,57	0,67	23,97	3,71
	Maximum	5840	80	19,90	4,70	0,66	24,44	3,72
30	Minimum	2860	35	18,76	3,83	0,68	---	---
	Nominal	4090	55	19,00	4,00	0,67	---	---
	Maximum	5840	80	19,16	4,11	0,67	---	---
35	Minimum	2860	35	17,96	3,33	0,69	---	---
	Nominal	4090	55	18,20	3,48	0,68	---	---
	Maximum	5840	80	18,36	3,58	0,68	---	---
40	Minimum	2860	35	17,11	2,88	0,70	---	---
	Nominal	4090	55	17,36	3,02	0,69	---	---
	Maximum	5840	80	17,53	3,10	0,69	---	---

Nominal capacity conditions: Exchanger air inlet temperature: 27°C DB/19°C WB for cooling y 20°C WB for heating mode.

(DW:dry bulb WB:wet bulb)

For another working conditions use correction factor tables.

#### Dissipated heat for cooling mode:

The heat to dissipate in the water exchanger for cooling mode is near to: Total capacity + total power input.

#### Absorbed heat for heating mode:

The heat absorbed in the water exchanger for heating mode is near to: Total capacity - total power input.

Water pressure drop has been calculated without water filter an option. With this option, the water pressure drop (kPa) is:

#### WATER PRESSURE DROP WITH WATER FILTER AWC/AWH

UNIT			AWH 002	AWH 003	AWC 007 AWH 007	AWC 008 AWH 008	AWC 010 AWH 010	AWC 012 AWH 012	AWC 015 AWH 015	AWC 018 AWH 018	AWC 020 AWH 020
Water flow	Minimum	l/h	-	-	20	25	30	35	35	40	45
	Nominal		-	-	30	35	50	55	55	60	75
	Maximum		-	-	45	60	80	90	80	100	115



# 1 - GENERAL CHARACTERISTICS

## 1.9.- CORRECTION FACTORS

### AIR FLOW

The data in the capacity tables, have been calculated for nominal air flow; with maximum/minimum air flows use these correction factors:

UNITS	AIR FLOW		COOLING			HEATING	
			Total capacity kW	EER	Sensible capacity kW	Total capacity kW	COP
002	Maximum	465	1.02	1.04	1.00	1.01	0.98
	Nominal	440	1.00	1.00	1.00	1.00	1.00
	Minimum	285	0.91	0.84	0.97	0.94	1.11
003	Maximum	550	1.04	1.10	1.01	1.03	0.95
	Nominal	515	1.00	1.00	1.00	1.00	1.00
	Minimum	335	0.94	0.89	0.99	0.95	1.08
007	Maximum	1430	1,02	1,06	1,02	1,02	0,96
	Nominal	1250	1,00	1,00	1,00	1,00	1,00
	Minimum	1010	0,96	0,92	0,97	0,99	1,08
008	Maximum	1620	1,01	1,03	1,01	1,01	0,98
	Nominal	1500	1,00	1,00	1,00	1,00	1,00
	Minimum	1250	0,96	0,93	0,98	0,98	1,06
010	Maximum	2100	1,02	1,04	1,03	1,01	0,98
	Nominal	1900	1,00	1,00	1,00	1,00	1,00
	Minimum	1550	0,96	0,92	0,98	0,97	1,07
012	Maximum	2200	1,02	1,03	1,03	1,01	0,98
	Nominal	2000	1,00	1,00	1,00	1,00	1,00
	Minimum	1620	0,96	0,92	0,98	0,97	1,09
015	Maximum	2610	1,01	1,03	1,01	1,01	0,98
	Nominal	2450	1,00	1,00	1,00	1,00	1,00
	Minimum	1850	0,94	0,89	0,97	0,96	1,12
018	Maximum	3100	1,01	1,03	1,01	1,01	0,98
	Nominal	2800	1,00	1,00	1,00	1,00	1,00
	Minimum	2060	0,92	0,87	0,97	0,95	1,12
020	Maximum	3500	1,01	1,03	1,02	1,01	0,98
	Nominal	3100	1,00	1,00	1,00	1,00	1,00
	Minimum	2450	0,94	0,89	0,98	0,96	1,12

### AIR INLET

#### COOLING MODE AWC/AWH

The data in the capacity tables has been calculated for air inlet temperature: 27°C DB and 19°C WB. For another conditions use these correction factors.

Air inlet temperature (D.B.)	Air inlet temperature (W.B.)		
21	15	TC (kW)	0,88
		SC (kW)	0,89
		Power input (kW)	0,99
24	17	TC (kW)	0,94
		SC (kW)	0,94
		Power input (kW)	1,00
27	19	TC (kW)	1,00
		SC (kW)	1,00
		Power input (kW)	1,00
29	21	TC (kW)	1,07
		SC (kW)	0,99
		Power input (kW)	1,00
32	23	TC (kW)	1,13
		SC (kW)	1,04
		Power input (kW)	1,01

#### HEATING MODE AWH

The data in the capacity tables has been calculated for air inlet temperature: 20°C DB. For another conditions use these correction factors.

Air inlet temperature (D.B.)		
15	TC (kW)	1,03
	Power input (kW)	0,91
17	TC (kW)	1,02
	Power input (kW)	0,95
20	TC (kW)	1,00
	Power input (kW)	1,00
22	TC (kW)	0,99
	Power input (kW)	1,04
24	TC (kW)	0,98
	Power input (kW)	1,08
26	TC (kW)	0,97
	Power input (kW)	1,12
28	TC (kW)	0,96
	Power input (kW)	1,16

TC: Total capacity  
 SC: Sensible capacity  
 D.B.: Dry bulb temperature  
 W.B.: Wet bulb temperature

# 1 - GENERAL CHARACTERISTICS.

## 1.10.- DIMENSIONS.

①	Compressor	⑦	Inlet water
②	Coil	⑧	Outlet water
③	Air filter	⑨	Power supply
④	Water exchanger	⑩	Drainage tube
⑤	Electrical box	⇨	Air configuration standard
⑥	Drip tray	➔	Air configuration option on site

### AWH 002-003

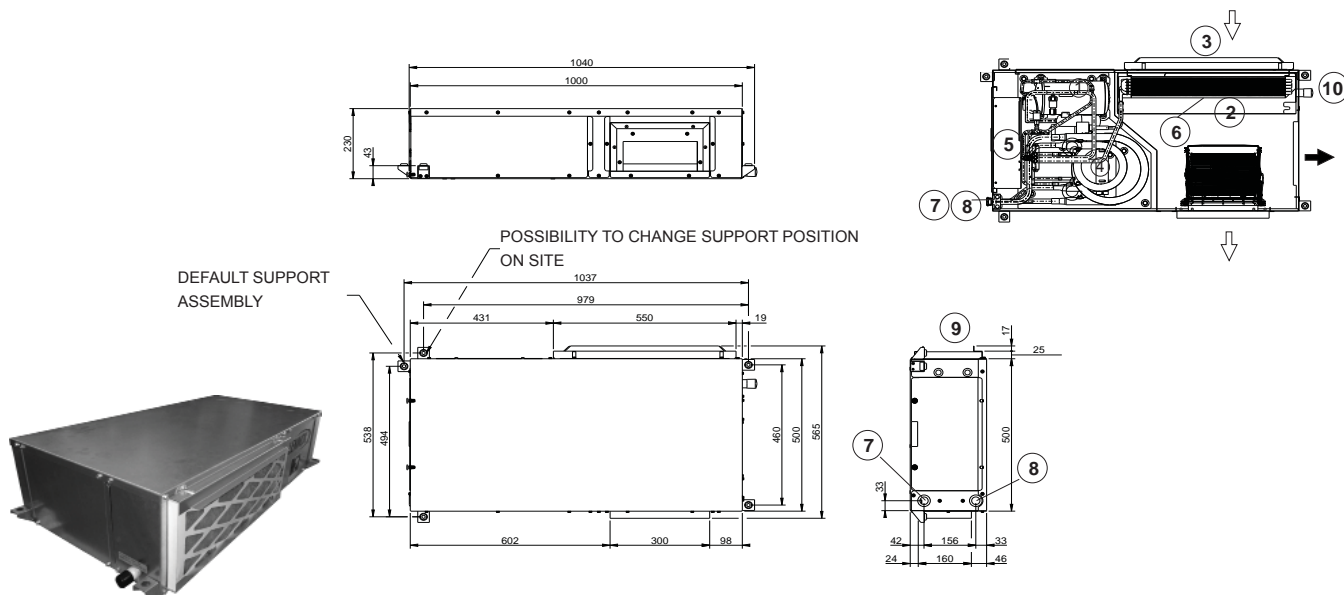

### AWC/AWH 007-008

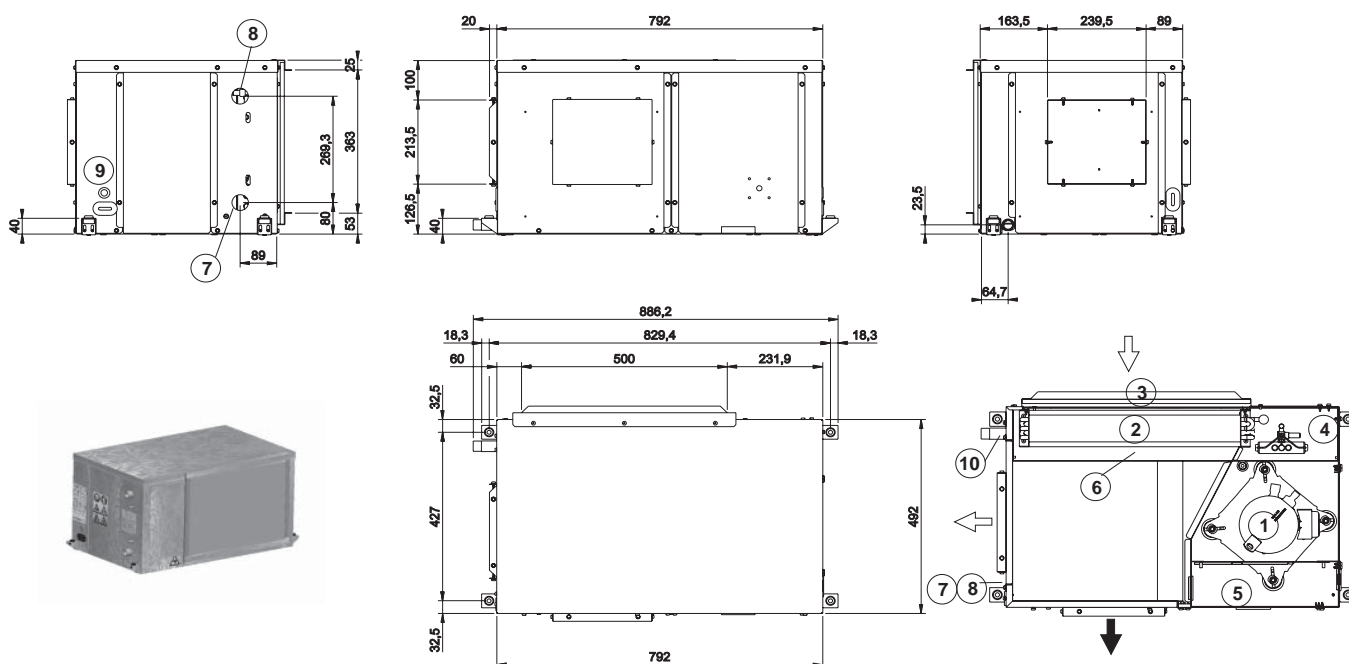

1 - GENERAL CHARACTERISTICS.

1.10.- DIMENSIONS.

AWC/AWH 010-012-015

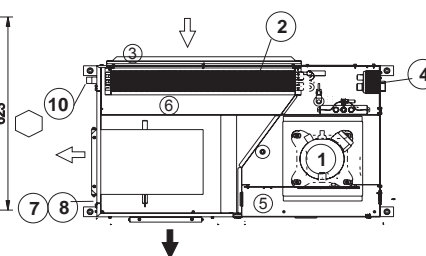
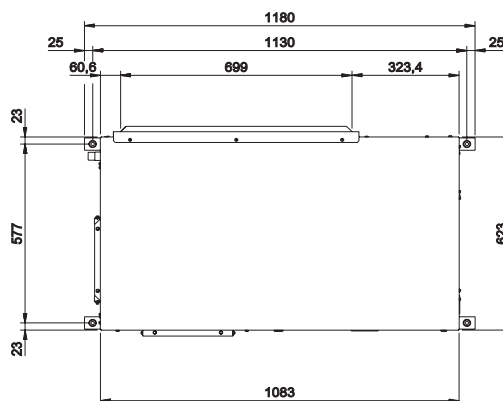
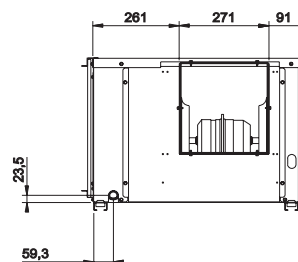
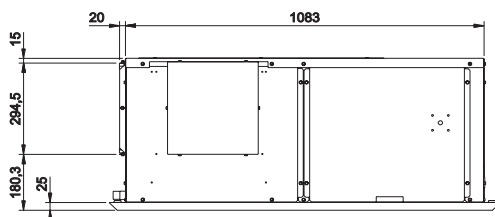
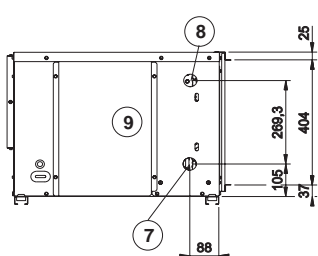

AWC/AWH 018-020

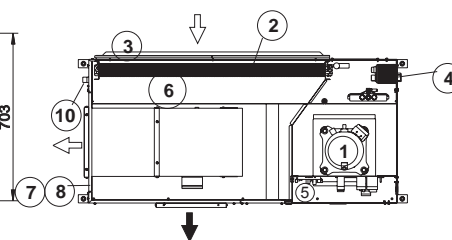
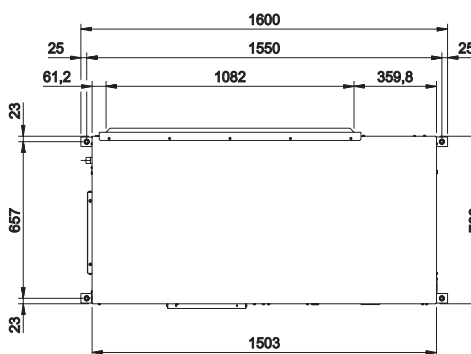
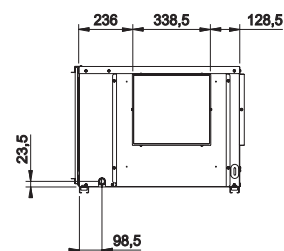
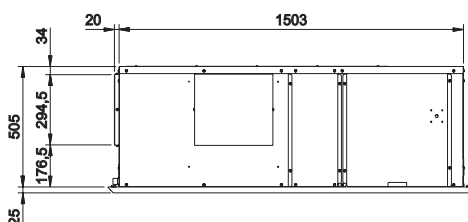
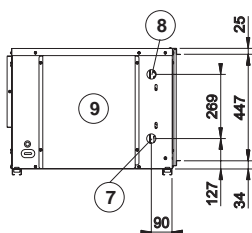

# 1 - GENERAL CHARACTERISTICS

## 1.11.- OPTIONS

### HEATING OPTIONS

#### ELECTRICAL HEATERS. (UNITS 007 to 020).

COOLING MODE AWC/AWH							
UNIT	007	008	010	012	015	018	020
Standard	2		3 (1F-3F)			5	
Medium	5		5(1F-3F)			9	
High			9 (3F)			12	

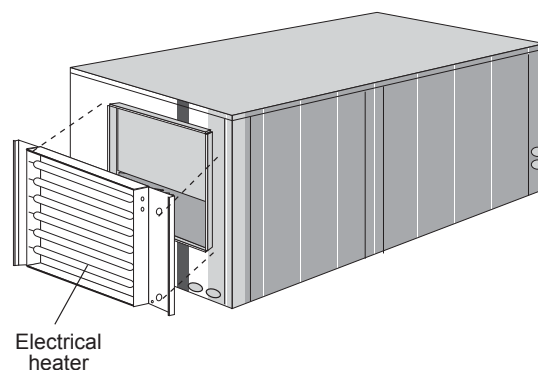

HEATING MODE AWH							
UNIT	007	008	010	012	015	018	020
Standard	2		3 (1F-3F)			5	

### INSTALLATION

Electrical heater is assembled in the unit.

Supply sensor is delivered outside the unit and it should be installed in the duct using the sheet metal fixation delivered with the unit.

See picture below for the installation.

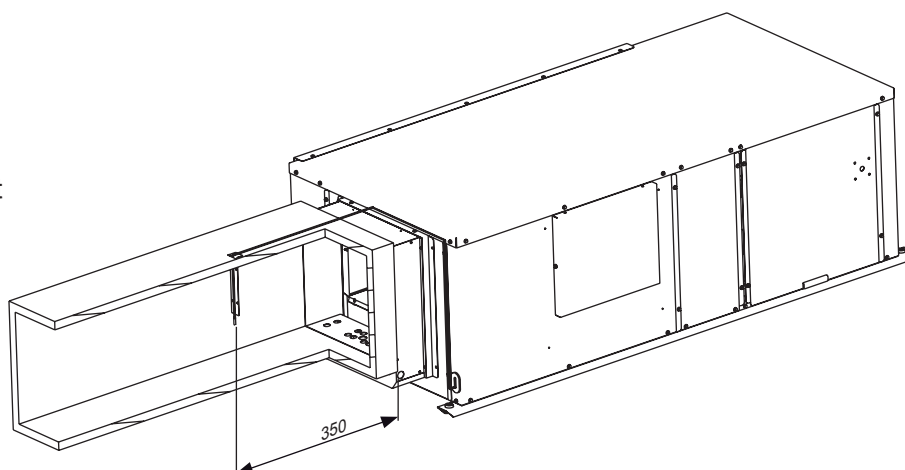

### CONTROL OPTIONS (ALL UNITS).

#### ModBus / BACNET / LONWORKS COMMUNICATION

The control board is equipped with a RS485 serial communication port to allow remote management through communication bus.

According to the wished communication protocol, our control board can be fitted with ModBUS®, LonWorks® or BacNET® communication interface.

#### DS60 (Service display)

This display provides access to the full controller menu to set all parameters. 24V customer display located at 30 meters maximum from the unit. Remote customer parameter reading and modification.

#### DM60 display for scheduling and zoning.

it is possible to enable up to 7 time zone per day with 4 different operating modes for each of the zone.



## 1 - GENERAL CHARACTERISTICS

### 1.11.- OPTIONS

#### **ELECTRICAL AND SAFETY OPTIONS.**

##### **MAIN SWITCH (UNITS 007 to 020).**

The main switch is equipped with a gadget, which allows opening the panel of the electrical box, when it is on OFF position.

Verify that the main switch is large enough to handle the current for the unit.

##### **THREE PHASE PROTECTION (THREE PHASE UNITS, 012 TO 020).**

Located at the electrical box of the unit, it assures that unit will not begin operation if connection phases of compressor are not correct. Should this occur, then just switch two phase connections.

#### **OTHER OPTIONS**

##### **COMPRESSOR ACOUSTIC JACKET. (UNITS 007 to 020).**

Each compressor is fitted with a compressor acoustic jacket this provides attenuation of the compressor noise that radiates from the unit when in operation.

# 1 - GENERAL CHARACTERISTICS

## 1.11.- OPTIONS



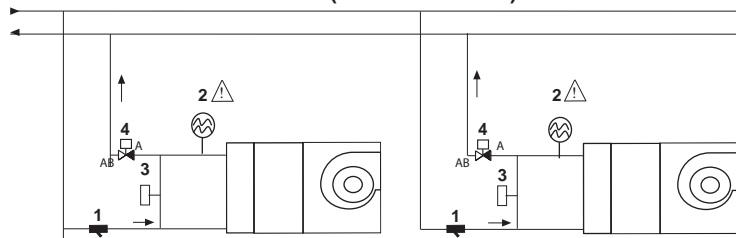

### HYDRAULIC OPTIONS (Supplied loose)

#### UNITS INSTALLATION WITH TWO WAY VALVES. (UNITS 007 to 020).

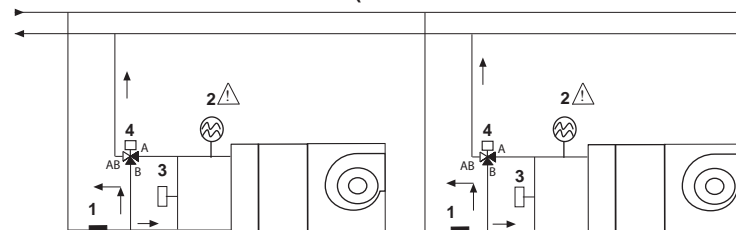

#### UNITS INSTALLATION WITH THREE WAY VALVES. (UNITS 007 to 020 and 002-003 LWT version).



	OPTION	DESCRIPTION	FUNCTION	TYPE	REGULATION	INSTALLATION (See units installation drawing above)
1	<b>WATER FILTER</b> (Units 007 to 020). 	This option is supplied loose. The water filter must be fitted in the water inlet of the unit, it protects the unit against particles (greater than 1 mm) getting inside the water circuit, and prevents the water interchanger clogging. The unit pressure drops are different when a water filter is installed (see table page 14).	Safety	Mesh 1mm	N/A	<b>Hydraulic connection:</b> 1" G H-H
2	<b>FLOW SWITCH.</b> (Units 007 to 020). 	This option is supplied loose. The flow switch stops the compressor if water flow is lower than the minimum flow. This option is incompatible with the water differential pressure switch option and with the low water temperature option.	Safety. <i>Minimum water flow</i>	Paddle	Factory setting	<b>Hydraulic connection:</b> 1" G M-H <b>Electric:</b> Remove shunt and connect according to the electrical drawing delivered with the unit.
3	<b>WATER DIFFERENTIAL PRESSURE SWITCH.</b> (Units 007 to 020). 	This option is supplied loose. The differential pressure switch stops the compressor if there is not water flow. This option is incompatible with the water switch.	Safety. Water flow YES/NO	Contact	N/A	<b>Hydraulic connection:</b> 3/8" G M <b>Electric:</b> Remove shunt and connect according to the electrical drawing delivered with the unit.
4	<b>LOW WATER TEMPERATURE.</b> (Units 007 to 020). 	The unit can work with water inlet temperatures below 15°C (down to 0°C) in cooling mode and heating mode above 25°C. It includes 3-way valve+actuator (supplied loose) and a high pressure transducer included into the unit. The valve with the actuator controls the water temperature based on condensing temperature by opening or closing the valve. The valve is managed by the unit control. The valve must be assembled in the return.	Water flow regulation	0-10 V	Control parameters factory setting	<b>Hydraulic connection:</b> 1"G. When installing the valve be sure that the flow direction is the correct. <b>Electric:</b> connect according to the electrical drawing. <b>2 ways installation:</b> It is possible to use the 3 ways valve delivered with the option and a cap (See fig.) 
5	<b>LOW WATER TEMPERATURE. (LWT VERSION).</b> (Units 002-003).	The unit can work with water inlet temperatures below 15°C (down to 0°C) in cooling mode and heating mode above 25°C. It includes 3-way valve+actuator (supplied loose) and a high pressure transducer included into the unit. The valve with the actuator controls the water temperature based on condensing temperature by opening or closing the valve. The valve is managed by the unit control. The valve must be assembled in the return.	Water flow regulation	0-10 V	Control parameters factory setting	<b>Hydraulic connection:</b> 3/4"G. <b>Flexible connections and a 3-way valve (4 ports).</b>

## 2.- OTHER FUNCTIONALITIES.

### AIRFLOW CONFIGURATION.

Units are assembled with supply airflow configuration on the side (90° angle to the return).

On site, the fan can easily be repositioned for an in-line supply.

For models AWC/H 018-020 the additional sheet metal parts and fan support are not needed and can be removed.

See picture below for airflow configuration.

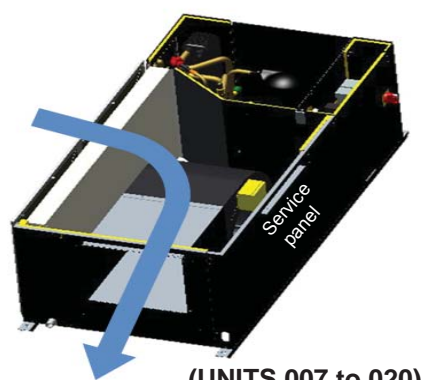

(UNITS 007 to 020)

Standard

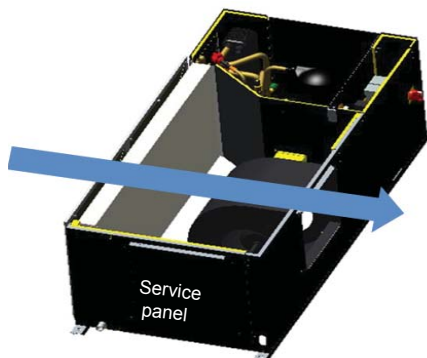

(UNITS 007 to 020)

On site

### AIRFLOW CHANGE (UNITS 007 to 020):

- 1 Unscrew and remove the unit's roof
- 2 Unscrew and remove access panel
- 3 Properly cut and remove the insulation material located behind the access panel
- 4 Install the insulation material inside the service panel (Alu scotch)
- 5 Unscrew the screws used to position the fan
- 6 On model 018 and 020 remove the additional support metal sheet
- 7 Turn the fan so that it will be positioned in line
- 8 Fix the fan with the screws
- 9 Screw the access panel on the side of the unit in order to close the original supply area.

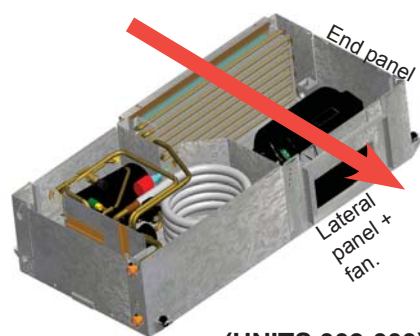

(UNITS 002-003)

Standard

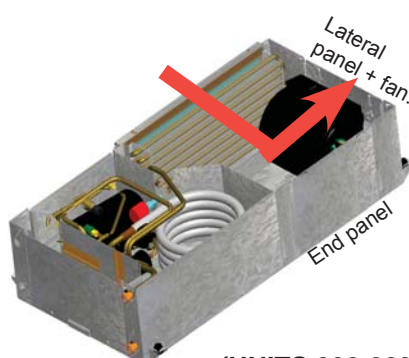

(UNITS 002-003)

On site

### AIRFLOW CHANGE (UNITS 002-003):

- 1 Unscrew both lateral + fan and end panel.
- 2 Swap the panel's positions.
- 3 Fix them to the structure.

### CIRCULATION PUMP ALIMENTATION.

It is possible to connect a circulation pump to the unit and to power it. 230 V supply, maximum 1A. See electrical folio delivered with the unit to know where it should be connected.

### DISTANCE CONTROL.

It is possible to switch to stand by mode from a distance. See electrical folio delivered with the unit to know where it should be connected.

### ON/OFF SIGNAL SUPPLY.

It is possible to send ON/OFF signal indicating whether the compressor is engaged.

To do so it is possible to connect to J14 plug and to modify the alarm by this information using a DS60 expert menu. It should be asked and done while commissioning the unit by a certified Lennox technician.

It is also possible to connect to the circulation pump connection. But the connection is supplied with 230V. It would be necessary to install a relay to get a on/off volt free contact.

### SENDING A 0-10 V SIGNAL (FOR EXAMPLE TO CONTROL A VALVE).

When the customer wants to connect a valve to regulate the unit operation, Lennox do recommend to select the Low Water Loop option which includes a 3-way valve (with possibility to convert to a 2-way valve by closing the B-gate) as well as a high pressure transducer. To export a 0-10V signal for another application, it is necessary to ask for a commissioning by a Lennox certified technician.

### SENDING A 230 V 3 POINTS SIGNAL (FOR EXAMPLE TO CONTROL A VALVE).

When the customer wants to connect a valve to regulate the unit operation, Lennox do recommend to select the Low Water Loop option which includes a 3-way valve (with possibility to convert to a 2-way valve by closing the B-gate) as well as a high pressure transducer. To export a 230V 3 points signal for another application, it is necessary to ask for a commissioning by a Lennox certified technician.

### 3 - INSTALLATION

#### 2.1.- PRE - INSTALLATION

Prior to install the equipment, make sure of the following points:

- Leave enough space for access to air supply, water section, power supply and condensed outlet.
- The water section must have the correspondent valves.
- Easy extraction of the air filter.
- Easy access to lateral panel for easy accessibility to all services of the unit.
- Unit must be mounted with antivibration.
- The electrical section must be done following legal normative
- Check that the tension is the same as installation place.
- Keep in mind power supply for maximum consumption for each unit.
- Check water quality, across analysis according to local normative. If quality of water is not good, it may be necessary to install a device to decalcify.
- The water must be analysed; the water circuit installed must include all items necessary for treatment of the water: filters, additives, intermediate exchangers, bleed valves, vents, isolating valves etc... depending on the results of the water analysis.

**We do not advise operation of the units with open loops which can cause problems with oxygenation, or operation with untreated ground water.**

Use of untreated or improperly treated water can cause deposits of scale, algae and sludge or cause corrosion and erosion. It is advisable to call in a qualified water treatment specialist to determine what kind of treatment will be necessary. The manufacturer cannot accept liability for damage caused by the use of untreated or improperly treated water, salt water or brine.

Here are our non exhaustive recommendations given as an indication:

- No NH<sub>4</sub><sup>+</sup> ammonium ions in the water, they are very detrimental for copper. <10mg/l
- Cl<sup>-</sup> Chloride ions are detrimental for copper with a risk of perforations by corrosion by puncture. < 10 mg/l.
- SO<sub>4</sub><sup>2-</sup> sulphate ions can cause perforating corrosion.< 30 mg/l.
- No fluoride ions (<0.1 mg/l).
- No Fe<sup>2+</sup> and Fe<sup>3+</sup> ions with dissolved oxygen. Dissolved iron < 5 mg/l with dissolved oxygen < 5 mg/l. Over those values, it means a corrosion of steel which may generate a corrosion of copper parts under deposit of Fe – this is mainly the case with shell and tube heat exchangers.
- Dissolved silicon: silicon is an acid element of water and can also lead to corrosion risks. Content < 1mg/l.
- Water hardness: TH >2.8 K. Values between 10 and 25 can be recommended. This will facilitate scale deposit that can limit corrosion of copper. TH values that are too high can cause piping blockage over time.
- TAC < 100.
- Dissolved oxygen: Any sudden change in water oxygenation conditions must be avoided. It is as detrimental to deoxygenate the water by mixing it with inert gas as it is to over-oxygenate it by mixing it with pure oxygen. The disturbance of the oxygenation conditions encourages destabilisation of copper hydroxides and enlargement of particles.
- Specific resistance – electric conductivity: the higher the specific resistance, the slower the corrosion tendency. Values above 3000 Ohm/cm are desirable. A neutral environment favours maximum specific resistance values. For electric conductivity values in the order of 200-6000 S/cm can be recommended.
- pH: pH neutral at 20°C (7 < pH < 8)



It is very important that the unit works with water flows between maximum and minimum values according to the tables. You have to calculate water pump and install regulation valve if they are needed, in order to be sure that the unit works with water flow values indicated in the tables. Specially for heat pump units AWH in heating mode, if the unit works with water flow below specified values, the unit can be seriously damaged, water exchanger can be frozen.



### 3 - INSTALLATION

#### 2.2.- UNIT INSTALLATION

Units must be installed by qualified technicians. Any modifications done on the units will be made under customer's responsibility, and Lennox conformity declaration certificate will not be valid.



**Make sure to disconnect power supply before carrying out any type of work on the unit.**

Hidraulic circuit:

- Make sure that water connections are correct, **water inlet (down side), water outlet (upper side)**.



**Water filter in the inlet water connection has to be used. The step of the mesh should be less than  $\dot{A}$  1.5 mm which avoids welded and dirty get to the unit. (Units 007 to 020).**

Lennox offers this element as an option.

- Install cut off valves at inlet and outlet water connections, because of in case of repairs, the hydraulic circuit can be independent.



**Use flexible components for the hydraulic connection between the unit and the installation in order to prevent the transmission of vibrations.**

- Install water inlet and water outlet connections with a differential gauge device in order to see the pressure difference between the outlet an inlet connections.
- At the end Install an adequate water pump, and all the necessary elements for the installation

#### AIR FLOW:

Airflow can be adjusted though the unit remote display between maximum/nominal/minimum

With "AUTO" the controller regulates the airflow between maximun and minimum values to assure the correct unit operation mode.

#### DRAINAGE TUBE

- Use the flexible tube connected to the drip tray as a drainage tube. Cause a siphon with this tube in order to avoid the inlet of scents from the installation to the unit.

Install a siphon from the drainage tube of the drip tray with a difference in height of 80 mm to prevent from not evacuating due to the negative pressure created by the fans. The pipe will slope down 2% to make it easier for the condensates to drain off.

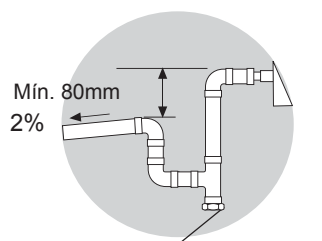

Inspection and cleaning stopper



**Legislation does not allow refrigerant gas emissions to the atmosphere, so the refrigerants have to be recycled to avoid being released to the atmosphere. Those recycled refrigerants shall be processed afterwards by an authorized waste manager.**

**Those components derived from the recycling of the unit have to be managed by authorized waste manager or be left in local waste facilities according the local normative in each country.**

### 3 - INSTALLATION

#### 3.2.- UNIT INSTALLATION

##### INSTALLATION PROCESS

After supply the power to the unit and connect inlet/outlet water :

- Connect the gauges in high pressure and low pressure side.
- Use a temperature probe in the compressor gas pipe and another ones in the inlet and outlet water pipes.
- Start water pump.
- Make sure to close the unit all panels have to be correctly situated.
- Start the unit and make sure that the thermostat temperature adjustment is correct.
- Check the correct water flow with a differential gauge device connected between the inlet and outlet water connections in order to know the pressure difference. Check it according to the capacity table values.

In addition, you can know the correct water flow with Dt measurement (inlet temperature °C - outlet temperature °C).

This value has to be the same as the value calculated with this formula:

##### a) Cooling mode

$$\Delta t = \frac{[\text{Cooling capacity (kW)} + \text{Total power input (kW)}] \times 860}{\text{Water flow (l/h)}}$$

##### b) Heating mode

$$\Delta t = \frac{[\text{Heating capacity (kW)} + \text{Total power input (kW)}] \times 860}{\text{Water flow (l/h)}}$$

All the data water flow, cooling / heating capacity and power input are on the capacity tables according to each model and the working conditions.

After a few minutes, when the unit will be stabilised, you have to verify :

- High and low pressure values and in addition saturation temperatures according to the correct working mode of the unit.
- Gas reheating values are below 12°C.

If it is not correct, please check expansion system and refrigerant leaks.



**If the compressor noise is very high and in addition, high and low pressure values are similar, it can be possible a wrong phase electrical connection. In this case, please change the connection for two phases. (Units 012 to 020).**

- Outlet and inlet water temperature are correct according to the water flow which is between specified values (units 007 to 020).

After verification of the correct working mode, please stop the unit, disconnect the gauges and temperature probes, and clean water filter.

The unit can be used properly until next maintenance revision.

## 4 - COMMISSIONING AND OPERATION

### 4.1.- PRELIMINARY CHECKS BEFORE STARTUP

- Check that the **power supply** is the same as stated on the Rating Plate which is in agreement with the electrical diagram for the unit and that cable sizes are correct.
- Check that **tightness of the electrical connections to their terminals and to ground.**
- Check with your hand that the **fans are turning freely.**
- Check the **control panel connections.**  
(If the connection is incorrect, the unit will not operate and the control panel display will not light).

### 4.2.- PRELIMINARY CHECKS AT STARTUP

To start the unit, **follow the instructions given in the User Manual for the control** supplied with the unit (requiring operation in any of the modes, cooling, heating, or automatic).

After a time delay, the unit will start.

With the unit operating, check that the **fans are turning freely and in the correct direction.**

CHECK THAT THE COMPRESSOR IS ROTATING IN THE CORRECT DIRECTION. (UNITS 012 to 020).

- If you have the option phase rotation indicator, use it to check the correct rotation.
- If you do not have three phase return lock, check the correct direction of rotation. The suction pressure decreases and the discharge pressure increases when the compressor is started.
- If the connection is incorrect, rotation will be reversed, causing a high noise level and a reduction in the amount of current consumed. If this occurs, the compressor's internal protection system will operate to shut down the unit. The solution is to disconnect, reverse two of the phases and connect again.

WITH OPERATING UNIT, CHECK:

- Low pressure and high pressure.
- Use the evaporating and liquid temperature to calculate superheat and subcooling.
- Adjust the refrigerant charge and/or expansion valve according to the preceding values.

COMPRESSORS WITH OIL LEVEL.

The oil level must always be checked. When the compressor is at rest, the level should be between 1/4 and 3/4 in the sight glass, while when running the level should be between 3/4 and full.

In the event of having to add oil, remember the type of oil is synthetic POE.

The original oil charge in the compressor is ICI Emkarate RL32-3MAF. This type of oil must also be used when replacing the oil completely.

When only topping up, RL32-3MAF or Mobil EAC Artic 22C can be used.

## 4 - COMMISSIONING AND OPERATION

### 4.2.- PRELIMINARY CHECKS AT STARTUP



The unit must be installed in accordance with local safety codes and regulations and can only be used in a well ventilated area. Please read carefully the manufacturer's instructions before starting this unit

**All work on the unit must be carried out by a qualified and authorised employee.**

Non-compliance with the following instructions may result in injury or serious accidents.

#### Work on the unit:

The unit shall be isolated from the electrical supply by disconnection and locking using the main isolating switch. Workers shall wear the appropriate personal protective equipment (helmet, gloves, glasses, etc.).

#### Electrical system:

Electrical connections can become loose during transport. Please check them before starting-up the unit Compressors with specific rotation direction. Check the correct rotation direction of the fan before closing the compressor circuit breakers. If the direction is incorrect, the phases must be reversed at the head of the main switch. Work on electric components shall be performed with the power off (see below) by employees having valid electrical qualification and authorisation.

#### Refrigerating circuit(s):

After more than 12 hours of power cut, the crankcase heater (compressor) should be powered for 5 hours before any return to service. Non-compliance with this instruction can cause deterioration of the compressors.

Monitoring of the pressures, draining and filling of the system under pressure shall be carried out using connections provided for this purpose and suitable equipment.

To prevent the risk of explosion due to spraying of coolant and oil, **the relevant circuit shall be drained and at zero pressure before** any disassembly or unbrazing of the refrigerating parts takes place.

There is a residual risk of pressure build-up by degassing the oil or by heating the exchangers after the circuit has been drained. **Zero pressure shall be maintained** by venting the drain connection to the atmosphere on the low pressure side. The brazing shall be carried out by a qualified brazer. The brazing shall comply according to code ASME section IX following the procedures specific.

#### Before starting up

- Test the circuit to the maximum working pressure (see the nameplate).
- Verify the operation of the high pressure switch.
- Check the piping and the components of the refrigerant circuit.

#### Replacing components:

In order to maintain CE marking compliance, replacement of components shall be carried out using spare parts, or using parts approved by Lennox.

Only the coolant shown on the manufacturer's nameplate shall be used, to the exclusion of all other products (mix of coolants, hydrocarbons, etc.).

#### CAUTION:

In the event of fire, refrigerating circuits can cause an explosion and spray coolant gas and oil.



All the components derived from the recycling of the unit should be managed according local legislation, and have to be classified and separated while dealt by authorized waste manager or be left in local waste facilities.

Refrigerant fluids, electronic boards, heat exchangers and the oil extracted from the refrigerant circuit, as well as the oil recipients used must be recycled as hazardous waste according the local normative through an authorized waste manager or be left in local waste facilities. The rest of the components considered as non-hazardous wastes must be recycled according to the corresponding norms.

At the end of its life, the equipment should be recycled in local waste facilities or by an authorized waste manager.

## 5 - MAINTENANCE

### 5.1.- PREVENTIVE MAINTENANCE



**PREVENTIVE MAINTENANCE PREVENTS COSTLY REPAIRS.  
THIS REQUIRES PERIODIC INSPECTIONS:**

#### **GENERAL STATE OF THE CASING:**

Furniture, paint, damage due to shocks, rust spots, levelling and supporting, condition of the shock absorbers, if installed, screwed panels, etc.

#### **ELECTRICAL CONNECTIONS:**

State of hoses, tightness of screws, earthing, current consumption of the compressor and fans and check that the unit is receiving the correct voltage.

#### **COOLING CIRCUIT:**

Check that the pressures are correct and that there are no leaks. Check that there is no damage to the pipe insulation, that the condition of the coils is good and that they are not blocked by bits of paper or plastic drawn in by the air flow, etc.

#### **COMPRESSOR:**

If a sight glass is fitted, check the oil level.  
Check the condition of the silentbloc mountings.

#### **FANS:**

Check that fans turn freely and in the correct direction without excessive noise.

#### **CONTROL:**

Check Set Points and normal operation.

## 5 - MAINTENANCE

### 5.2.- CORRECTIVE MAINTENANCE



**IMPORTANT**  
**MAKE SURE THAT THE UNIT IS FULLY DISCONNECTED FROM THE POWER SUPPLY WHEN CARRYING OUT ANY TYPE OF WORK ON THE MACHINE.**

If any **component** in the cooling circuit **is to be replaced**, follow these recommendations:

- Always **use original replacement parts**.
- If the component can be isolated, it is not necessary to remove the entire **refrigerant charge**, if the component cannot be isolated and the refrigerant charge is removed, it should be removed through the Schrader valves located in the outdoor section. Create a slight vacuum as a safety measure.
- Regulation **prohibits the release of refrigerant into the atmosphere**.
- If cuts must be made in the pipe work, use pipe cutters. **Do not use saws or any other tools that produce filings**.
- **All brazing must be carried out in a nitrogen atmosphere** to prevent corrosion forming.
- Use **silver alloy brazing rod**.
- **Take special care that the flame** from the torch is directed away from the component to be welded and cover with a wet rag to prevent overheating.

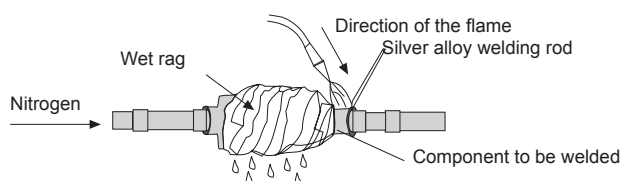

- **Take very special care if 4-way or check valves are to be replaced** since these have internal components that are very heat-sensitive such as plastic, teflon, etc.
- If a **compressor is to be replaced**, disconnect it electrically and un-braze the suction and discharge lines. Remove the securing screws and replace the old compressor with the new one. Check that the new compressor has the correct oil charge, screw it to the base and connect the lines and electrical connections.
- **Evacuate above and below through the Schrader valves** of the outdoor unit until -750 mm Hg is reached. Once this level of vacuum has been reached, keep the pump running for at least one hour.  
**DO NOT USE THE COMPRESSOR AS A VACUUM PUMP.**
- **Charge the unit with refrigerant** according to the data on the Rating Plate for the unit and **check that there are no leaks**.



#### **PRECAUTIONS TO BE TAKEN WHEN USING OF R-410A Refrigerant:**

R-410A refrigerant is used in the unit; the following standard precautions for this gas should therefore be taken:

- The Vacuum Pump must have a Check Valve or Solenoid Valve fitted.
- Pressure Gauges and Hoses for exclusive use with R-410A Refrigerant should be used.
- Charging should be carried out in the Liquid Phase.
- Always use scales to weigh-in charge
- Use the Leak Detector exclusive for R-410A Refrigerant.
- Do not use mineral oil, only synthetic oil to ream, expand or make connections.
- Keep pipes wrapped before using them and be very thorough about any possible dirt (dust, filings, burrs, etc.).
- When there is a leak, collect what remains of the charge, create a vacuum in the unit and completely recharge with new R-410A Refrigerant.
- Brazing should always be carried out in a nitrogen atmosphere.
- Reamers should always be well sharpened.









lennoxemeia.com

**SALES OFFICES :**

**BELGIUM AND LUXEMBOURG**

☎ + 32 3 633 3045

**FRANCE**

☎ +33 1 64 76 23 23

**GERMANY**

☎ +49 (0) 211 950 79 600

**ITALY**

☎ + 39 02 495 26 200

**NETHERLANDS**

☎ + 31 332 471 800

**POLAND**

☎ +48 22 58 48 610

**PORTUGAL**

☎ +351 229 066 050

**RUSSIA**

☎ +7 495 626 56 53

**SPAIN**

☎ +34 915 401 810

**UKRAINE**

☎ +38 044 585 59 10

**UNITED KINGDOM AND IRELAND**

☎ +44 1604 669 100

**OTHER COUNTRIES :**

**LENNOX DISTRIBUTION**

☎ +33 4 72 23 20 20



Due to Lennox's ongoing commitment to quality, the specifications, ratings and dimensions are subject to change without notice and without incurring liability.

Improper installation, adjustment, alteration, service or maintenance can cause property damage or personal injury. Installation and service must be performed by a qualified installer and servicing agency