

INSTALLATION AND
OPERATING MANUAL

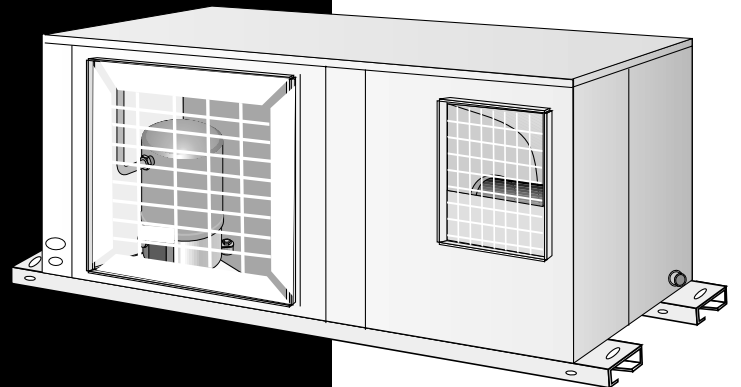

PROVIDING **GLOBAL SYSTEM** SOLUTIONS

FLATAIR
KFC / KFH

GREAT BRITAIN , IRELAND : LENNOX INDUSTRIES LTD
tel. : + 44 1604 599400
fax : + 44 1604 594200
e-mail : marketing@lennoxind.com

BELGIUM : LENNOX BENELUX N.V./S.A.
tel. : + 32 3 633 30 45
fax : + 32 3 633 00 89
e-mail : info.be@lennoxbenelux.com

CZECH REPUBLIC : JANKA RADOTIN AS
tel. : + 420 2 510 88 111
fax : + 420 2 579 10 393
e-mail : janka@janka.cz

FRANCE : LENNOX FRANCE
tel. : + 33 1 60 17 88 88
fax : + 33 1 60 17 86 58
e-mail : accueil@lennoxfrance.com

GERMANY : LENNOX DEUTSCHLAND GmbH
tel. : + 49 69 42 09 79 0
fax : + 49 69 42 09 79 40
e-mail : info.de@lennoxdeutschland.com

NETHERLANDS : LENNOX BENELUX B.V.
tel. : + 31 33 2471 800
fax : + 31 33 2459 220
e-mail : info@lennoxbenelux.com

POLAND : LENNOX POLSKA Sp. z o. o.
tel. : + 48 22 832 26 61
fax : + 48 22 832 26 62
e-mail : lennoxpolska@inetia.pl

PORTUGAL : LENNOX CLIMATIZAÇÃO LDA.
tel. : +351 22 999 84 60
fax : +351 22 999 84 68
e-mail : info@lennoxportugal.com

RUSSIA : LENNOX DISTRIBUTION MOSCOW
tel. : + 7 095 246 07 46
fax : + 7 502 933 29 55
e-mail : lennox.dist.moscow@mtu-net.ru

SLOVAKIA : LENNOX SLOVAKIA
tel. : + 421 7 44 87 19 27
fax : + 421 7 44 88 64 72

SPAIN : LENNOX REFAC S.A.
tel. : + 34 902 400 405
fax : + 34 91 542 84 04
e-mail : marketing@lennox-refac.com

UKRAINE : LENNOX DISTRIBUTION KIEV
tel. : + 380 44 213 14 21
fax : + 380 44 213 14 21
e-mail : jankauk@uct.kiev.ua

OTHER EUROPEAN COUNTRIES,
AFRICA,
MIDDLE-EAST : LENNOX DISTRIBUTION
tel. : + 33 4 72 23 20 14
fax : + 33 4 72 23 20 28
e-mail : marketing@lennoxdist.com



LENNOX[®]

www.Lennox.com

COD: MIL67E-0701
09-2001

TABLE OF CONTENTS

DATA PAGE FOR UNIT COMMISSIONING

PAGE 2

1.- GENERAL CHARACTERISTICS

PAGE

1.1.- PHYSICAL DATA	3
1.2.-FAN SERVICES	3
1.3.- ELECTRICAL DATA	4
1.4.- OPERATING LIMITS	5
1.5.- UNIT DIMENSIONS	6-8
1.6.- SIZES OF STANDARD AND OPTIONAL OPENINGS	9-10
1.7.- AVAILABLE OPTIONS	11

2.- INSTALLATION

PAGE

2.1.- INSTALLATION GUIDELINES	12
2.2.- UNIT INSTALLATION	12
2.3.- OPTIONAL TASK PRIOR TO UNIT INSTALLATION: CHANGING THE POSITION OF BLOWERS AND AIR INTAKE	13-14
2.4.- UNIT LOCATION AND WEIGHT DISTRIBUTION	15
2.5.- INSTALLATION CLEARANCES	16
2.6.- DRAINS	16
2.7.- REFRIGERANT CONNECTIONS	17-20
2.8.- ELECTRICAL CONNECTIONS	21-22

3.- COMMISSIONING AND OPERATION

PAGE

3.1.- PRELIMINARY CHECKS	23
3.2.- STEPS TO FOLLOW FOR COMMISSIONING THE UNIT	24

4.- MAINTENANCE

PAGE

4.1.- PREVENTIVE MAINTENANCE	25
4.2.- CORRECTIVE MAINTENANCE	26
4.3.- FAILURE DIAGNOSIS	27

DATA PAGE FOR UNIT COMMISSIONING

UNIT: _____ SERIAL No.: _____

CONTROL PANEL IDENTIFICATION CODE _____

INSTALLATION ADDRESS: _____

INSTALLER: _____ INSTALLER TEL.: _____

INSTALLER ADDRESS: _____

DATE OF COMMISSIONING: _____

CHECKS:

SUPPLY VOLTAGE: _____ RATED VOLTAGE OF THE UNIT: _____

	YES	NO
UNIT ON SHOCK ABSORBERS	<input type="checkbox"/>	<input type="checkbox"/>
DRAINAGE WITH TRAP	<input type="checkbox"/>	<input type="checkbox"/>
GENERAL POWER SUPPLY CONNECTION	<input type="checkbox"/>	<input type="checkbox"/>
CONTROL PANEL CONNECTION	<input type="checkbox"/>	<input type="checkbox"/>
COMPRESSOR OIL LEVEL INDICATOR	<input type="checkbox"/>	<input type="checkbox"/>

DATA INPUT:

COOLING CYCLE

Air Intake Temperature to the coil: _____ °C

Air Output Temperature to the Coil: _____ °C

High Pressure: _____

Low Pressure: _____

HEATING CYCLE

Air Intake Temperature to the coil: _____ °C

Air Output Temperature to the Coil: _____ °C

High Pressure: _____

Low Pressure: _____

ELECTRIC POWER CONSUMPTION (Amps)

Compressor _____ / _____ / _____

Fan _____ / _____ / _____

Compressor _____ / _____ / _____

Fan _____ / _____ / _____

Options Installed: _____

Comments: _____

1.- GENERAL CHARACTERISTICS



KFHA: Heat pump unit R-22
KFCK: Cooling only unit R-407C
KFHK: Heat pump unit R-407C

1.1.- PHYSICAL DATA

UNIT MODEL		10	12	16	22	24	28	30
COMPRESSOR	Nº / Type	1 / Scroll	1 / Scroll	1 / Scroll	1 / Scroll	1 / Scroll	1 / Scroll	1 / Scroll
NET WEIGHT								
	Cooling only units KFC Kg	130	135	180	195	265	275	285
	Heat pump units KFH Kg	135	140	185	200	270	280	285
REFRIGERANT CHARGE		NITROGEN (*)						

(*) The units are supplied with nitrogen gas, this must be removed and charge the unit with refrigerant R-22 or R-407C, depends on unit model.

(See page 20, to calculate model refrigerant charge)

1.2.- FAN SERVICES

MODELS		AIR FLOW m ³ /h						
		10	12	16	22	24	28	30
AVAILABLE STATIC PRESSURE Pa.	0	3500	3400	4950	5900	6600	6400	6400
	10	3410	3325	4850	5800	6490	6300	6300
	20	3300	3160	4750	5700	6340	6200	6200
	30	3190	3075	4625	5600	6225	6100	6100
	40	3080	2980	4525	5495	6100	5980	5980
	50	2970	2890	4425	5390	5960	5870	5870
	60	2840	2790	4325	5280	5850	5725	5725
	70	2700	2690	4225	5180	5710	5600	5600
	80	2560	2580	4125	5075	5600	5490	5490
	90	2410	2400	4040	4975	5480	5375	5375
	100	2350	---	3940	4875	5350	5250	5250
	110	---	---	3840	4775	5200	5100	---
	120	---	---	3750	4675	5090	5000	---
	130	---	---	---	4575	4950	---	---
	140	---	---	---	4460	4800	---	---
	150	---	---	---	4350	4650	---	---
160	---	---	---	---	4500	---	---	

 NOMINAL AIR FLOW

1.- GENERAL CHARACTERISTICS

1.3.- ELECTRICAL DATA

UNIT MODELS		KFHA 10	KFHA 12	KFHA 16	KFHA 22	KFHA 24	KFHA 28	KFHA 30
Voltage	V/f (50 Hz)	230V/ 1Ph						
		230V-400V/ 3Ph						
Rated absorbed power								
Compressor (cooling cycle)	Kw	2,60	3,41	4,11	5,02	5,85	7,41	8,83
Compressor (heating cycle)	Kw	2,03	2,54	2,94	3,70	4,85	5,48	6,48
Fan	Kw	0,52	0,52	1,10	1,60	1,60	1,60	1,60
Total power in cooling cycle	Kw	3,12	3,93	5,21	6,62	7,45	9,01	10,43
Total power in heating cycle	Kw	2,55	3,06	3,50	5,30	6,45	7,08	8,08
Maximum current								
Compressor	A	18,6						
		16,7/7,2	19,3/8,7	19,9/11,5	22,4/12,9	25,3/14,6	28,5/16,3	36,5/21,0
Fan	A	3,1	3,1					
				4,8/2,8	7,4/4,3	8,1/4,7	8,1/4,7	8,1/4,7
Total current	A	21,7						
		19,8/10,3	22,4/11,8	24,7/14,3	29,8/17,2	33,4/19,3	36,6/21,0	44,6/25,7
Start up current	A	99						
		96/47	102/54	148/77	193/110	181/109	183/83	177/109

UNIT MODELS		KFCK 10 KFHK 10	KFCK 12 KFHK 12	KFCK 16 KFHK 16	KFCK 22 KFHK 22	KFCK 24 KFHK 24	KFCK 28 KFHK 28	KFCK 30 KFHK 30
Voltage	V/f (50 Hz)	230V/ 1Ph						
		230V-400V/ 3Ph						
Rated absorbed power								
Compressor (Cooling cycle)	Kw	2,79	3,68	4,41	5,20	6,05	7,43	9,25
Compressor (heating cycle)	Kw	2,26	3,21	3,60	3,84	5,65	6,25	7,37
Fan	Kw	0,52	0,52	1,10	1,60	1,60	1,60	1,60
Total power in Cooling cycle	Kw	3,31	4,20	5,51	6,80	7,65	9,03	10,85
Total power in heating cycle	Kw	2,78	3,73	4,70	5,44	7,25	7,85	8,97
Maximum current								
Compressor	A	18,6						
		16,7/7,2	19,3/8,7	19,9/11,5	22,4/12,9	25,3/14,6	28,5/16,3	36,5/21,0
Fan	A	3,1	3,1					
				4,8/2,8	7,4/4,3	8,1/4,7	8,1/4,7	8,1/4,7
Total Current	A	21,7						
		19,8/10,3	22,4/11,8	24,7/14,3	29,8/17,2	33,4/19,3	36,6/21,0	44,6/25,7
Start up current	A	99						
		96/47	102/54	148/77	193/110	181/109	183/83	177/109

1.- GENERAL CHARACTERISTICS

1.4.- OPERATING LIMITS

(To install with LFXO / LFCK / LFHK / LFHA indoor unit)

OPERATING LIMITS FOR (COOLING ONLY) UNITS

		MAXIMUM TEMPERATURES	MINIMUM TEMPERATURES
COOLING CYCLE OPERATION	INDOOR TEMPERATURE	32° C DB / 23° C WB	21° C DB / 15° C WB
	OUTDOOR TEMPERATURE	DEPENDING ON MODEL (TABLE 1)	0° C (MODELS 22/24/28/30) 19° C (MODELS 10/12/16) (*)

(*) With condensation pressure control (optional), 0 °C minimum outdoor operating temperature

OPERATING LIMITS FOR (heating PUMP) UNITS

		MAXIMUM TEMPERATURES	MINIMUM TEMPERATURES
COOLING CYCLE OPERATION	INDOOR TEMPERATURE	32° C DB / 23° C WB	21° C DB / 15° C WB
	OUTDOOR TEMPERATURE	DEPENDING ON MODEL (TABLE 1)	0° C (MODELS 22/24/28/30) 19° C (MODELS 10/12/16) (*)
heating CYCLE OPERATION	INDOOR TEMPERATURE	27° C DB	21° C BD / 15° C WB
	OUTDOOR TEMPERATURE	24° C DB / 18° C WB	-10° C DB / -11° C WB

(*) With condensation pressure control (optional), 0 °C minimum outdoor operating temperature

DB.- Dry Bulb Temperature
WB.- Wet Bulb Temperature

TABLE 1-COOLING CYCLE MAXIMUM OUTDOOR OPERATING TEMPERATURES

MODELS WITH REFRIGERANT R-407C

MODELS	10	12	16	22	24	28	30
With rated outdoor flow	45	43	44	45	46	42	41
With minimum outdoor flow	43	43	41	41	42	39	38

MODELS WITH REFRIGERANT R-22

MODELS	10	12	16	22	24	28	30
With rated outdoor flow	48	48	47	48	48	46	44
With minimum outdoor flow	46	45	45	46	44	42	40

1.- GENERAL CHARACTERISTICS

1.5.- UNIT DIMENSIONS

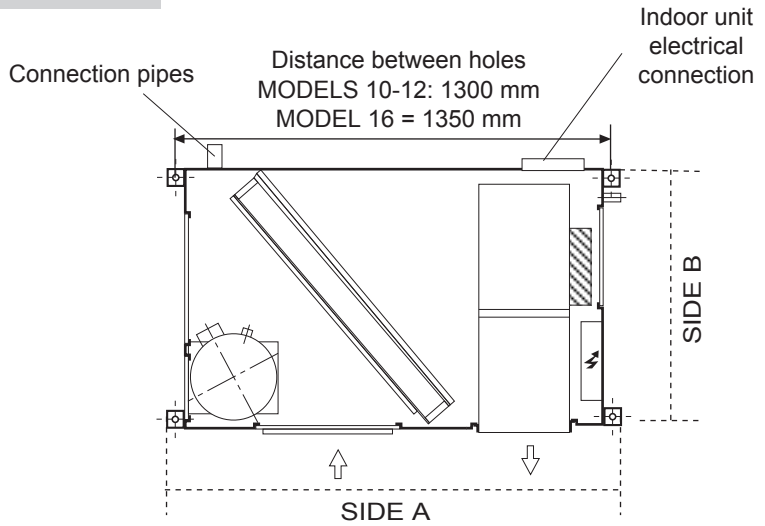

UNITES MODEL 10-12

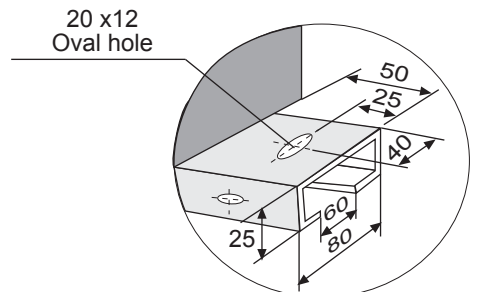
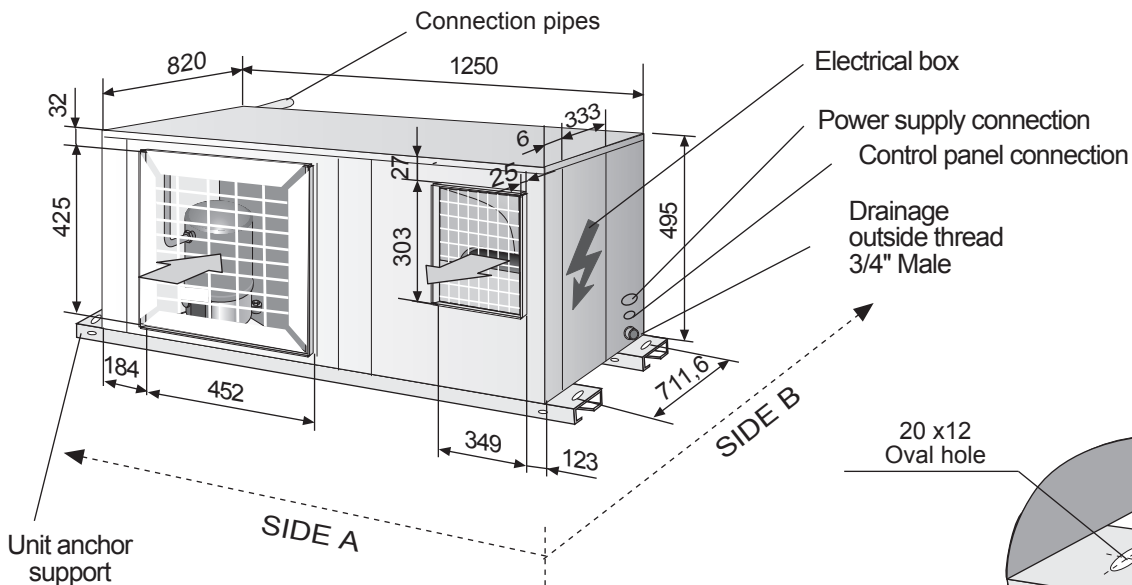

Detail drawing of unit anchor support

UNIT MODEL 16

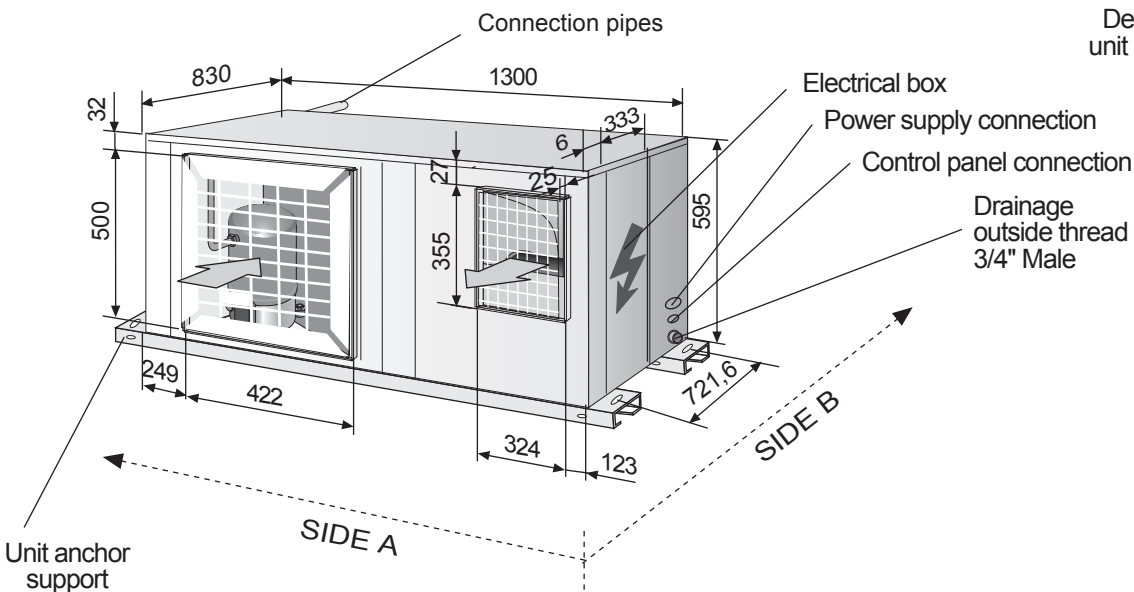

1.- GENERAL CHARACTERISTICS

1.5.- UNIT DIMENSIONS

UNIT MODEL 22

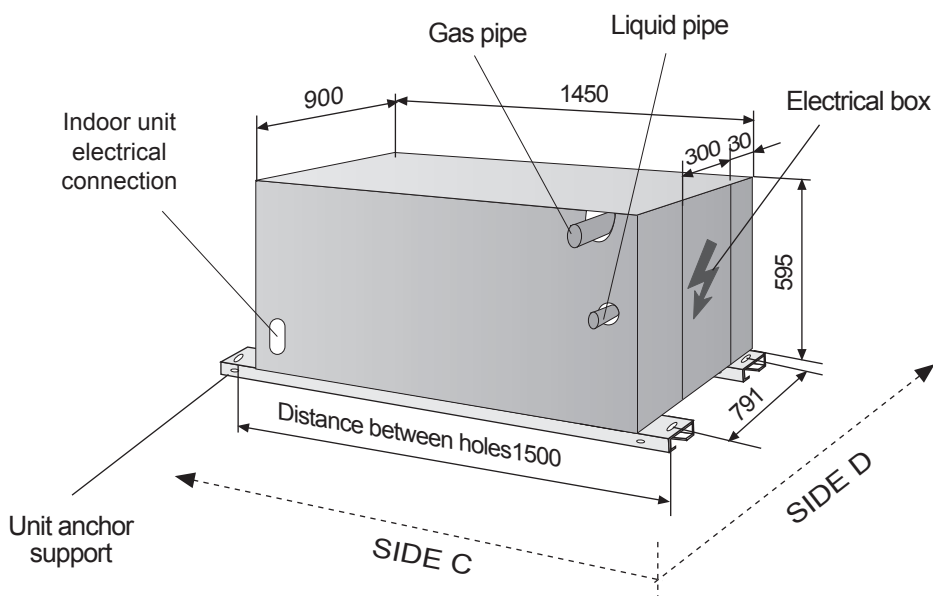
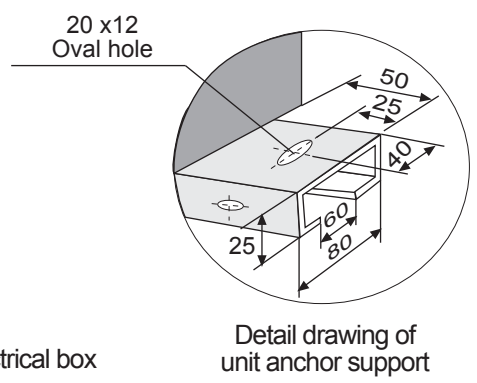
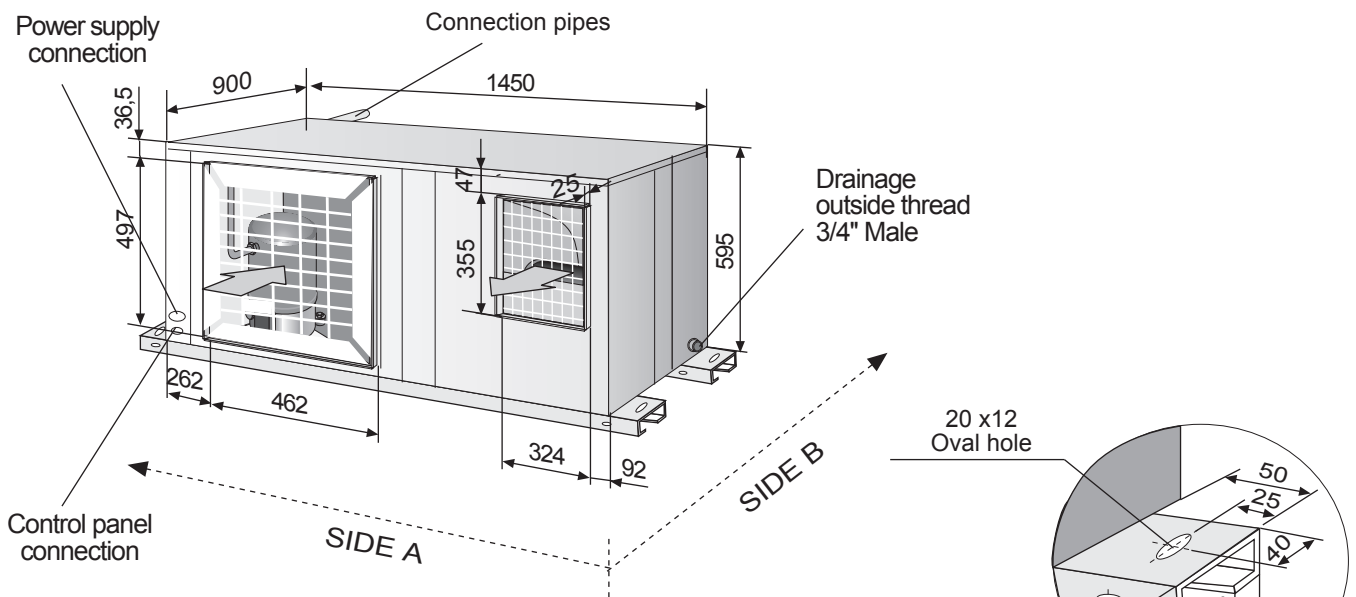
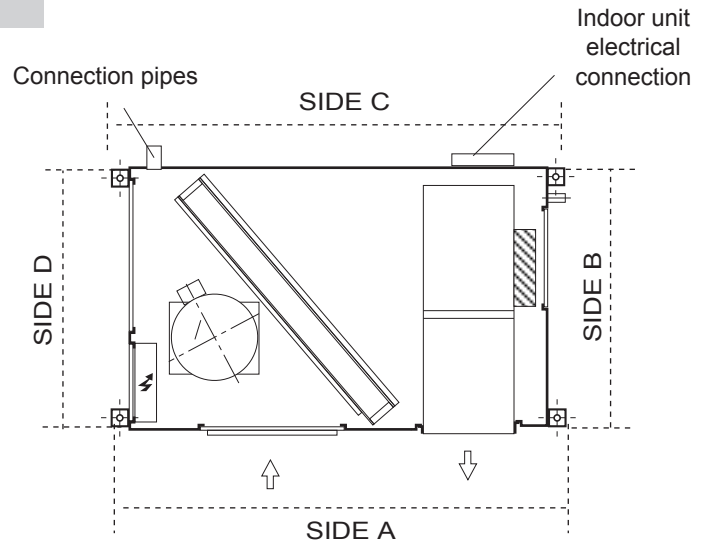

1.- GENERAL CHARACTERISTICS

1.5.- UNIT DIMENSIONS

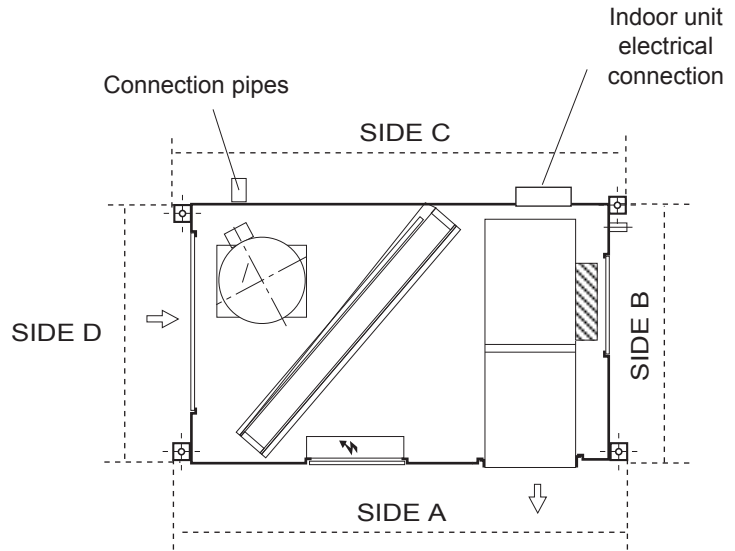

UNITES MODEL 24-28-30

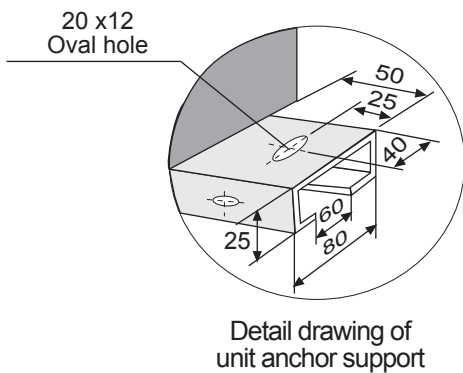
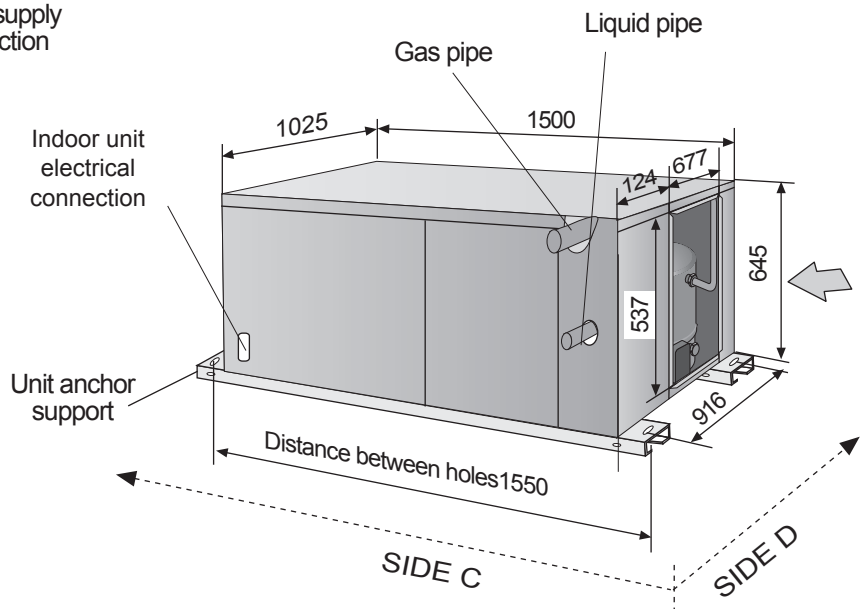
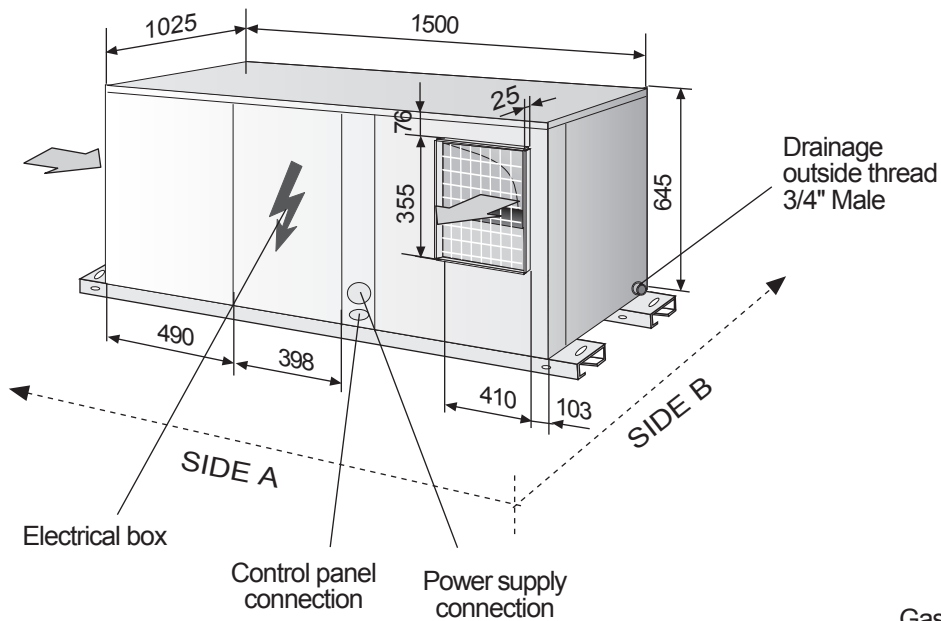

1.- GENERAL CHARACTERISTICS

1.6.- UNIT OPENING SIZES

UNITS MODELS 10-12

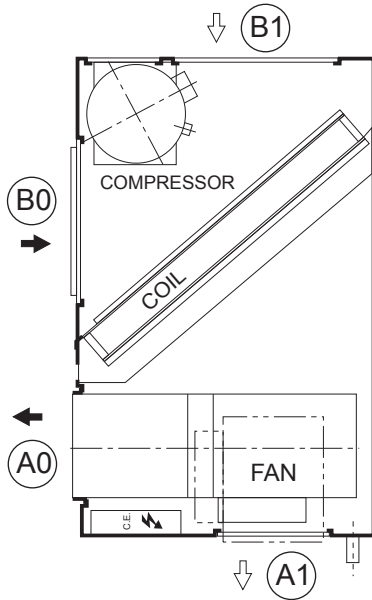

- ← STANDARD CONFIGURATION
- ⇐ OPTIONAL CONFIGURATION
- ⚡ ELECTRICAL BOX

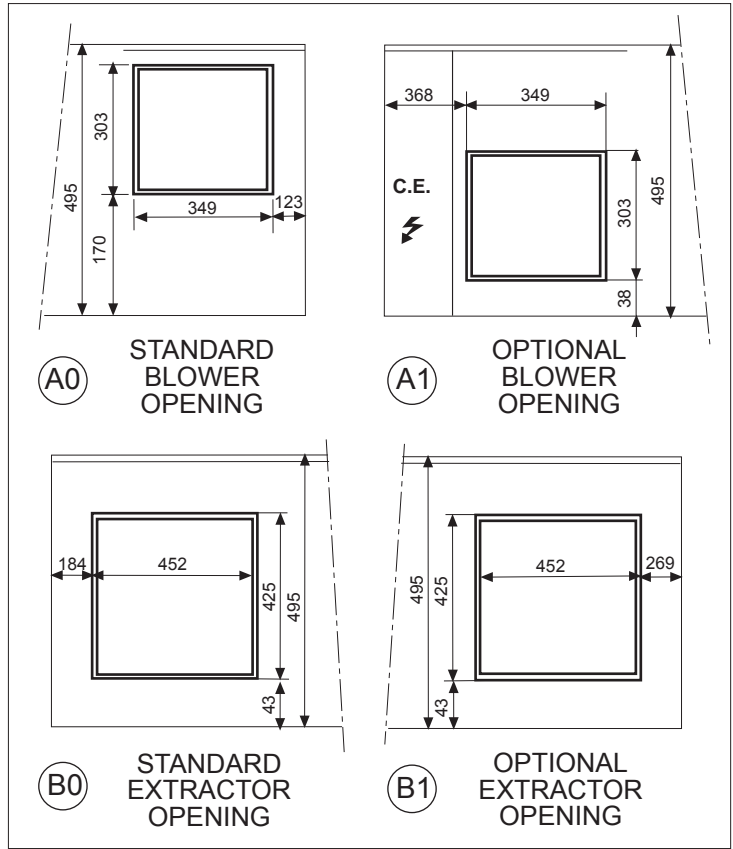

UNIT MODEL 16

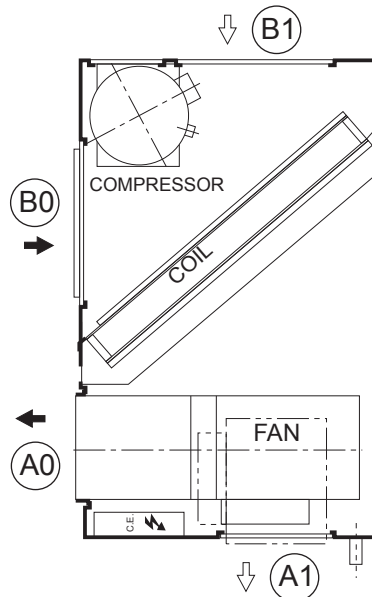

- ← STANDARD CONFIGURATION
- ⇐ OPTIONAL CONFIGURATION
- ⚡ ELECTRICAL BOX

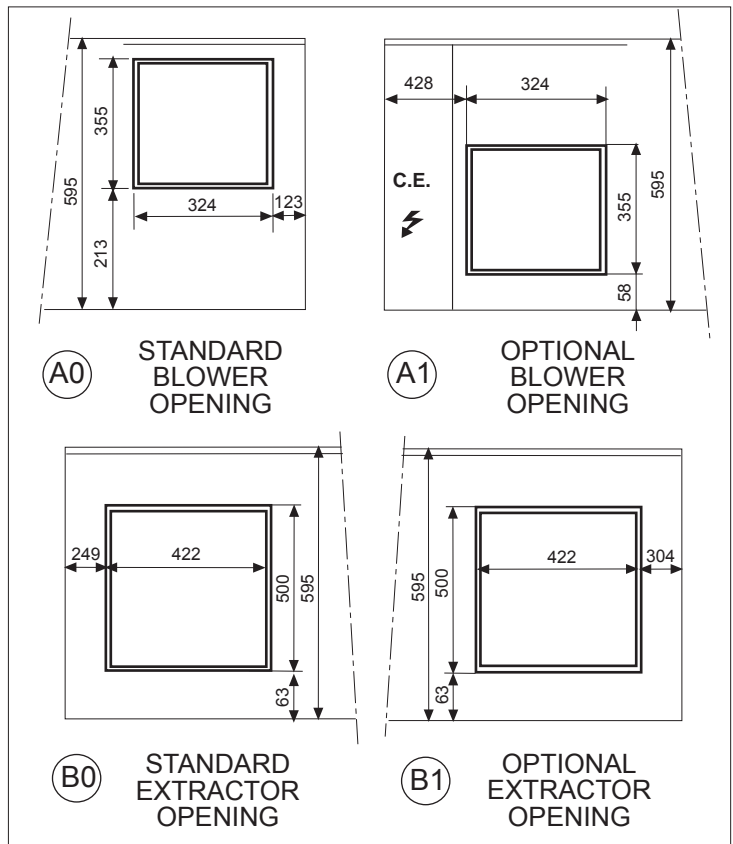

1.- GENERAL CHARACTERISTICS

1.6.- UNIT OPENING SIZES

UNIT MODEL 22

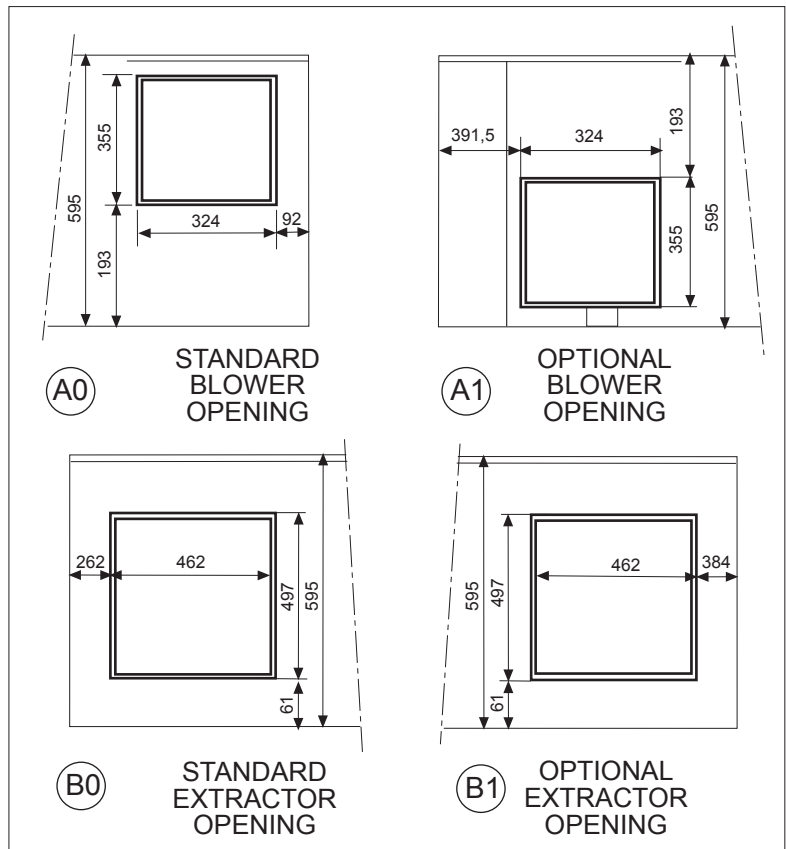
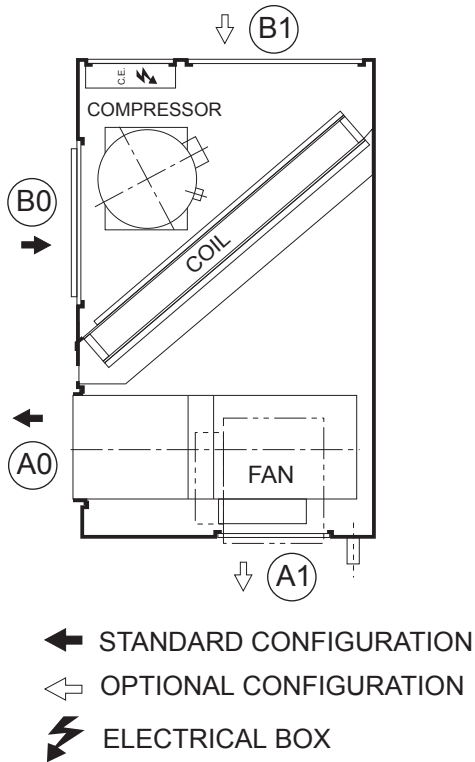

UNITS MODELS 24-28-30

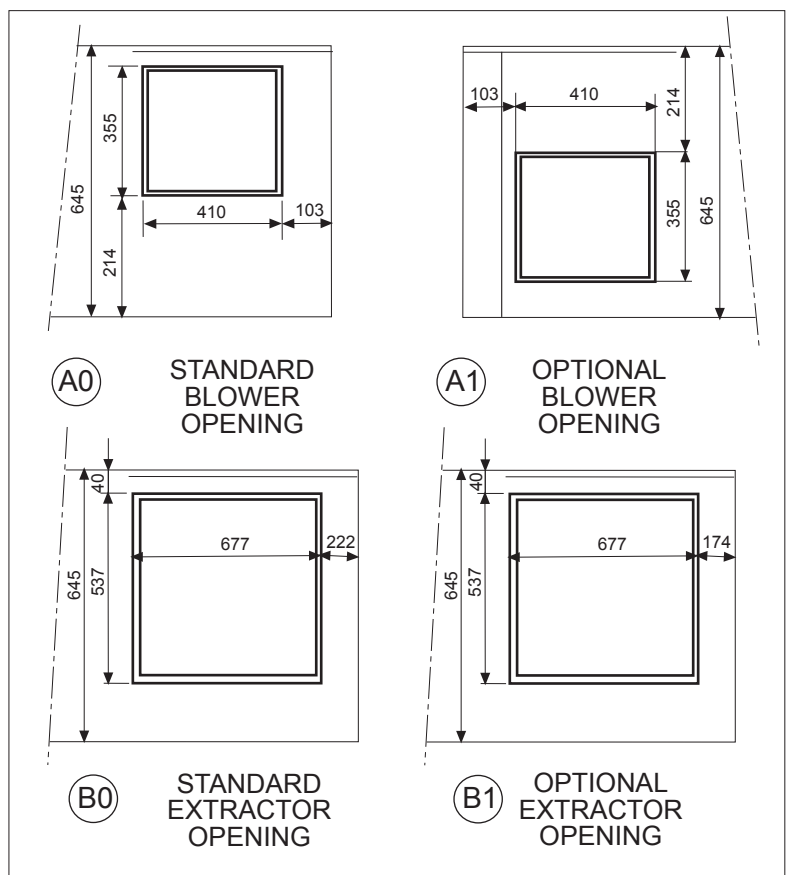
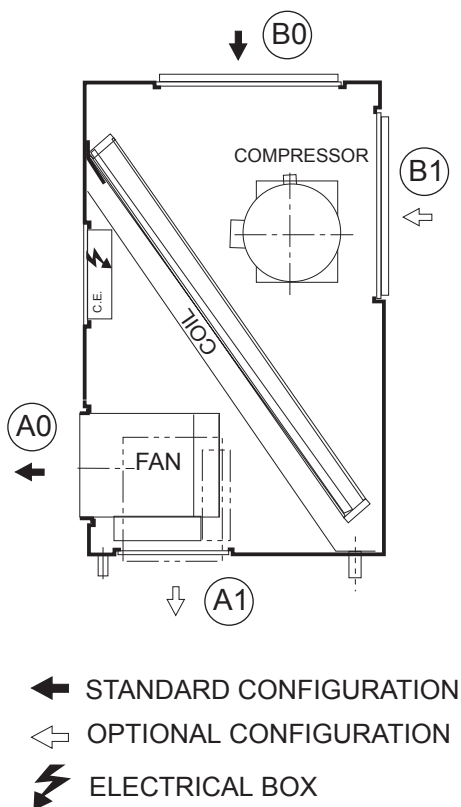

1.- GENERAL CHARACTERISTICS

1.7.- AVAILABLE OPTIONS

MAIN SWITCH

The main switch is located on the access panel to the electrical box in such a way that the unit is disconnected when the panel is opened.

(Refer to the size diagram on pages 7 to 10 to see the position of the electrical box access panel).

Check to make sure that the main switch is large enough to handle the current for the unit if electric heaters are installed.

PHASE SEQUENCER (THREE-PHASE UNIT)

The phase sequencer is located in the electrical box in the outdoor section, thus assuring that the unit will not begin operation while the phase connection of the compressor is not correct. Should this occur, then just switch two phase connections.

ON/OFF CONDENSATION PRESSURE CONTROL (MODELS 10-12-16)

The condensation pressure control consists of a pressure switch, which starts and stops the outdoor fan regulating the condensation temperature, thus the unit will be able to operate in the cooling cycle when the outdoor temperature is below 19°C.

HOT GAS BYPASS VALVE

The purpose of the BYPASS valve is to make it possible for the unit to operate at low outdoor temperatures (under 0°C), to be used in cooling-only and head-pump units.

It regulates the capacity of the compressor by injecting hot gas from the compressor discharge side to the evaporator.

CRANKCASE HEATER (COOLING-ONLY UNITS)

When the unit is operating at low outdoor temperatures it is advisable to fit a crankcase heater.

The purpose of the heater is to keep the oil in the compressor at the correct temperature while the compressor is stopped so that it can be properly lubricated when started again.

SOUND MUFFLER

Available for models 16, 22, 24, 28, 30.

Field assembled, designed to be installed at the extractor opening of the outdoor unit in order to reduce noise, particularly when the outdoor unit is installed without ducts, free discharge. This kit contains the sound muffler and adapter parts for fixing it to the unit.

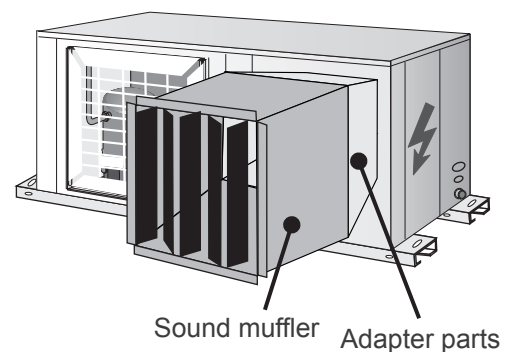

OUTDOOR MOUNTING KIT

Field assembly.

This kit is comprised of an air filter and grille for outdoor air intake which should be installed on the suction side of the outdoor unit, and the anti-rain hood which should be installed on the discharge side of the outdoor fan.

OUTDOOR AIR FILTER KIT

Field assembly.

The outdoor air filter should be installed on the outdoor air inlet of the outdoor unit and is recommended when working in heavily contaminated areas that may soil or clog the coil.

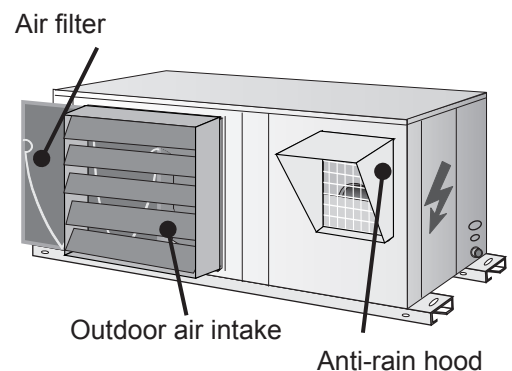

2.- INSTALLATION

2.1.- PRELIMINARY PREPARATIONS



All INSTALLATION, SERVICE and MAINTENANCE operations must be carried out by QUALIFIED PERSONNEL.

The unit must be transported in a HORIZONTAL POSITION on its metal bedplate profiles and TRANSPORTATION BLOCKS. Any other position may cause serious damage to the machine. When the unit is received, it should be checked to assure that there are no bumps or other damage, following the instructions on the packaging. If there is damage, the unit may be rejected by notifying the LENNOX Distribution Department and reporting why the machine is unacceptable on the transport agent's delivery notice. Any later complaint or claim made to the LENNOX Distribution Department, for this type of anomaly, cannot be considered under the Guarantee. Sufficient space must be allowed to facilitate placement of the unit. The unit may be mounted outdoors. There should be NO possibility of flooding if floor mounted.



When positioning the unit, be sure that the Rating Plate will always be visible since this data will be necessary to assure proper maintenance.

The units are designed to be installed with ducts, calculated by qualified technical staff. The joints to be used between ducts and the openings to the unit should be Elastic Joints. Avoid the use of BYPASS joints between the extraction air and input air in both the outdoor and indoor sections. The structure where the unit is placed must be able to support the weight of the unit during operation.

2.2.- UNIT RECEPTION

All the units have Metal Bedplate Profiles and Wooden Blocks for transportation.

These wooden blocks must be removed when positioning the unit in its final position.

PLACEMENT OF THE BEDPLATE AND TRANSPORTATION BLOCKS

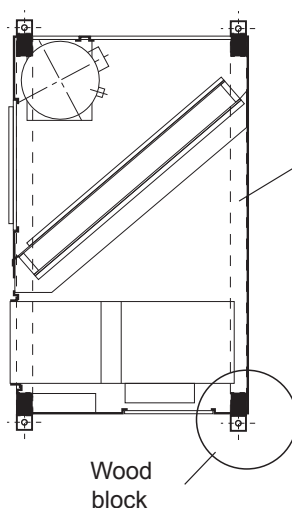

Bedplate profile

Wood block

To remove the transportation blocks, remove the screw and slide the block along the metal profile.

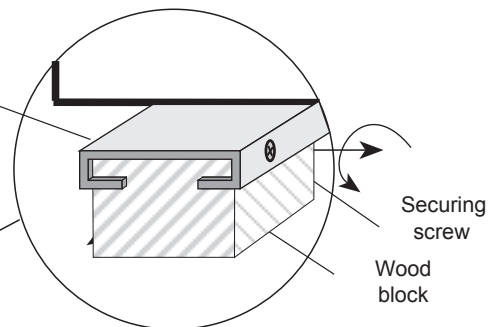

Securing screw

Wood block

Use separators

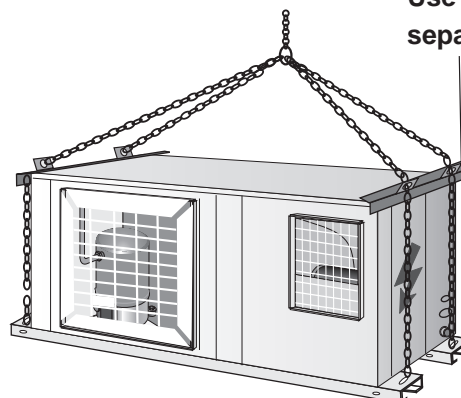

How to hoist the unit

If unloading and placement require the use of a crane, then secure the suspension cables as shown in the figure.

2.- INSTALLATION

2.3.- OPTIONAL OPERATIONS PRIOR TO UNIT INSTALLATION: CHANGE IN THE POSITION OF BLOWERS AND AIR INTAKE

UNITS MODELS 10-12-16-22

STANDARD AIR INTAKE AND BLOWERS

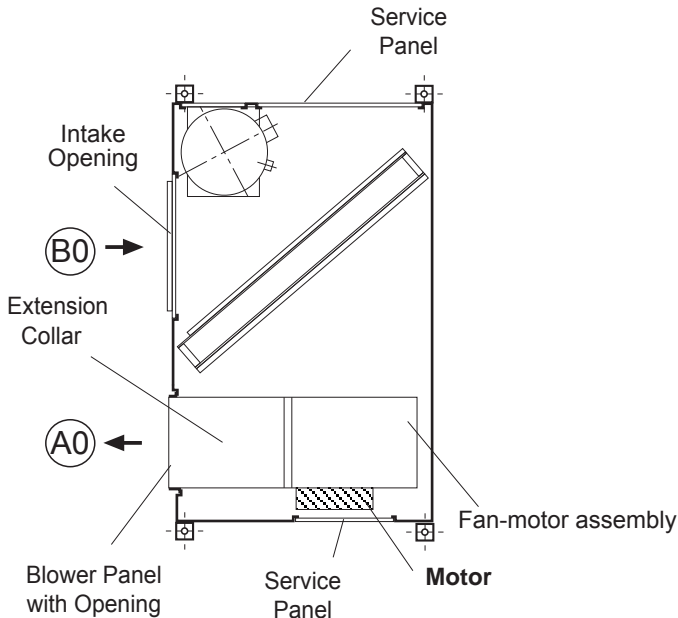

OPTIONAL AIR INTAKE AND BLOWERS

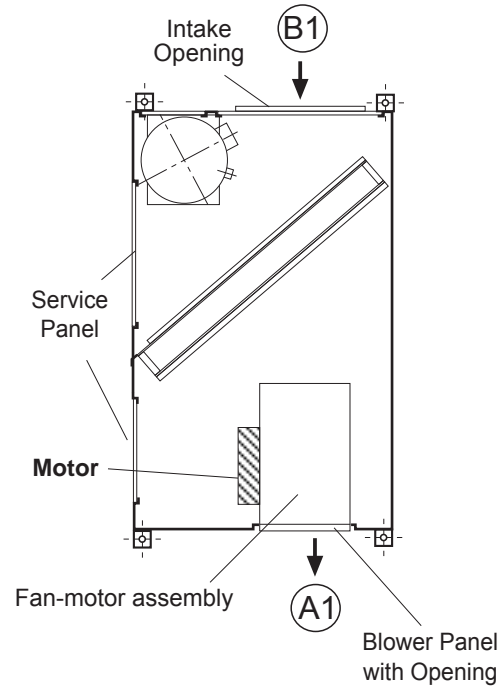

BLOWER:

From the position (A0) to the position (A1)

- 1) Remove the ceiling of the unit, the Blower Panel with Opening and the Service Panel.
- 2) Remove the motor-fan assembly from the unit unscrewing the supports from the base, and throwing away the extension collar, if there is one.
- 3) Unscrew the supports that have been left on the fan-motor assembly.
- 4) Turn the fan-motor assembly to its new position 90° horizontally and 180° on its shaft. The motor should now be accessible from the Service Panel in this new position.
- 5) Screw down the fan-motor assembly in its new position using the supports.
- 6) Assemble the Blower Panel with Opening and the Service Panel in its new position, taking special care with the weather stripping.

INLET:

From the position (B0) to the position (B1)

- 1) Remove the Intake Opening and the Service Panel.
- 2) Switch the position of the Opening and Service Panels.



SEE LOCATIONS AND SIZES FOR THE OPENINGS IN THEIR STANDARD AND OPTIONAL POSITIONS ON THE GENERAL MEASUREMENT DRAWINGS.

2.- INSTALLATION

2.3.- OPTIONAL OPERATIONS PRIOR TO UNIT INSTALLATION: CHANGE IN THE POSITION OF BLOWERS AND AIR INTAKE

UNITS MODELS 24-28-30

STANDARD AIR INTAKE AND BLOWERS

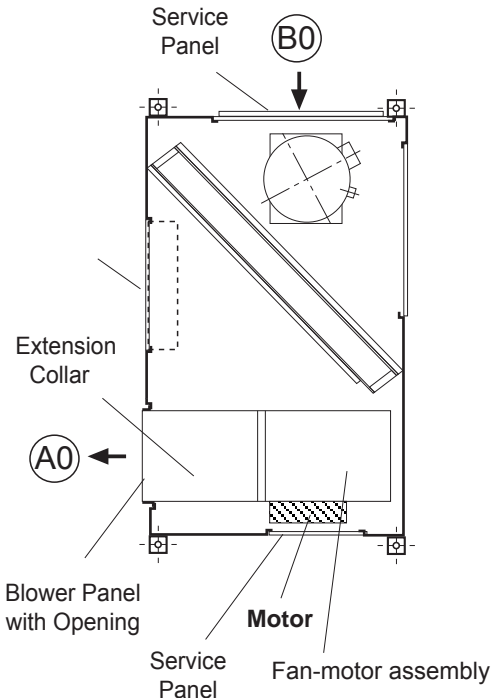

OPTIONAL AIR INTAKE AND BLOWERS

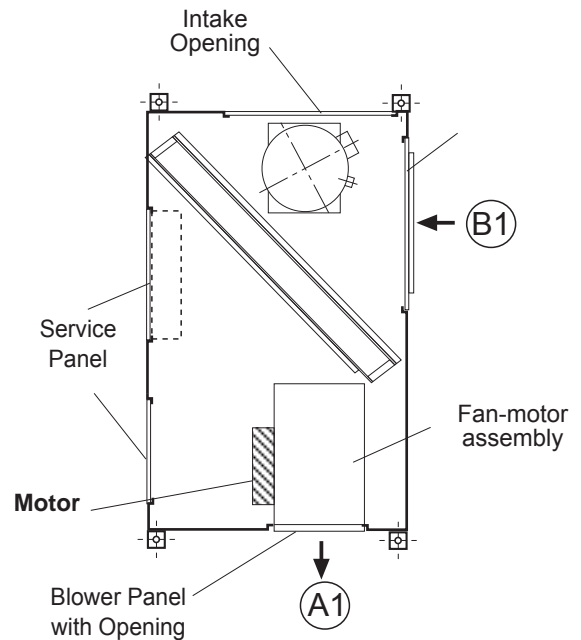

BLOWER:

From the position (A0) to the position (A1)

- 1) Remove the ceiling of the unit, the Blower Panel with Opening and the Service Panel.
- 2) Remove the motor-fan assembly from the unit unscrewing the supports from the base, and throwing away the extension collar, if there is one.
- 3) Unscrew the supports that have been left on the fan-motor assembly.
- 4) Turn the fan-motor assembly to its new position 90° horizontally and 180° on its shaft. The motor should now be accessible from the Service Panel in this new position.
- 5) Screw down the fan-motor assembly in its new position using the supports.
- 6) Assemble the Blower Panel with Opening and the Service Panel in its new position, taking special care with the weather striping.

INLET:

From the position (B0) to the position (B1)

- 1) Remove the Intake Opening and the Service Panel.
- 2) Switch the position of the Opening and Service Panels.



SEE LOCATIONS AND SIZES FOR THE OPENINGS IN THEIR STANDARD AND OPTIONAL POSITIONS ON THE GENERAL MEASUREMENT DRAWINGS.

2.- INSTALLATION

2.4.- UNIT LOCATION AND WEIGHT DISTRIBUTION

The bedplate is made up of three galvanized metal channels, capable of withstanding the weight of the units whether hung from the ceiling or mounted on the floor.

If the unit is floor mounted, then the profiles should be isolated with shock absorbing material such as anti-vibration or pads. If used, consult the weight distribution table below to make the correct selection. Keep in mind that fans rotate at approximately 850 rpm.

If the unit is hung, M-10 threaded rods should be used along with shock absorbing ceiling supports.

UNIT HUNG WITH RODS

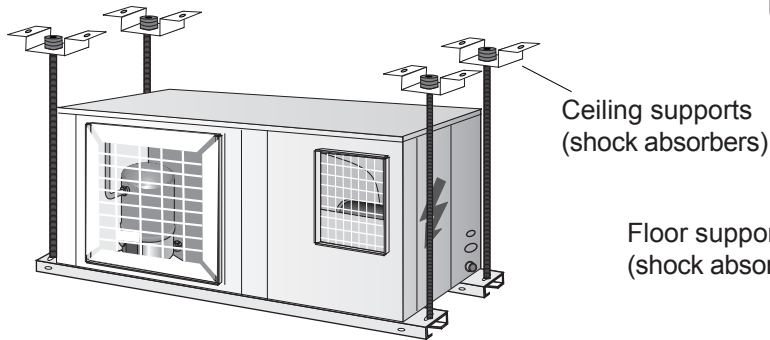

UNIT INSTALLED ON SHOCK ABSORBERS

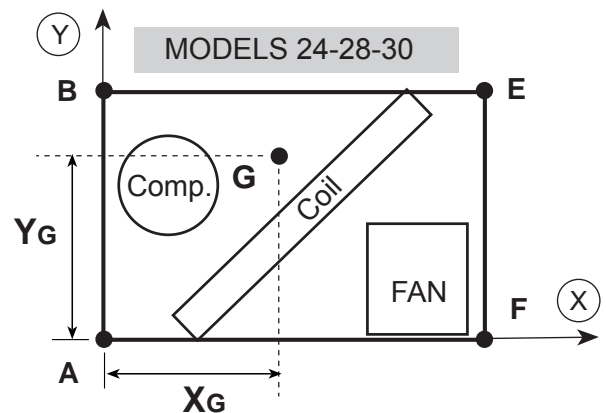
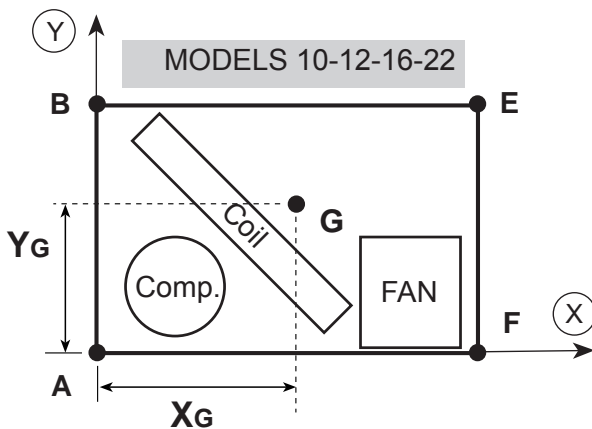
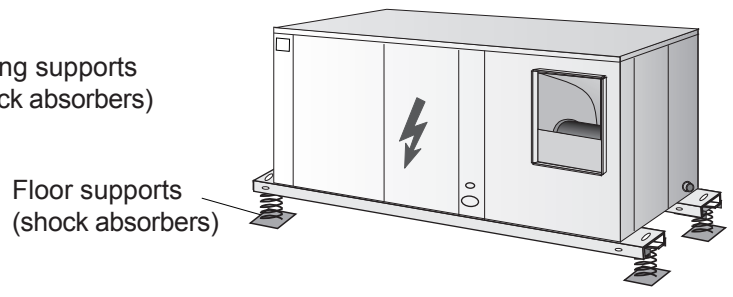

G POINT: Centre of gravity

TABLE 1:
WEIGHT DISTRIBUTION
AND CENTRE OF
GRAVITY COORDINATES

Point Model	WEIGHT DISTRIBUTION (Kg)					CENTRE OF GRAVITY COORDINATES (G) (mm.)	
	A	B	E	F	Total	X_G	Y_G
10	40	35	20	40	135	550	340
12	40	45	20	35	140	505	380
16	55	50	35	45	185	570	375
22	55	50	45	50	200	670	425
24	75	70	75	50	270	705	550
28	80	75	75	50	280	660	550
30	80	80	75	50	285	645	550

2.- INSTALLATION

2.5.- INSTALLATION CLEARANCES

Clearance around the unit for service and maintenance.

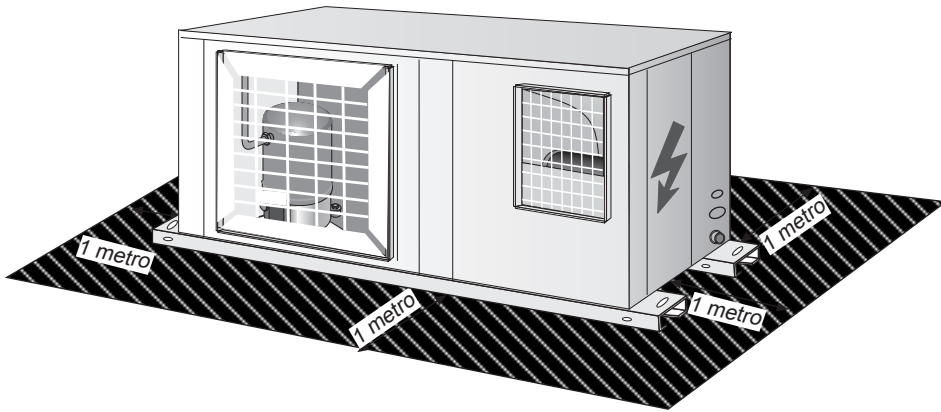

Consult other options for outdoor mounting or changes in position of the air return duct if the unit is to be hung.

2.6.- DRAINS

All heat Pump units have a $\frac{3}{4}$ " steel threaded drain pipe welded to the condensation tray.

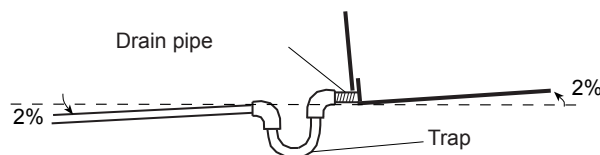

One PVC drain trap is supplied with the the heat pump units.

Connect the trap to the drain pipe on the unit and mount the drain pipe with at least a 2% incline from the trap.

Also slightly tip the unit (2%) toward the drainage side. Check that the condensation trays are clean and free from dirt and other debris from the works and that water drains correctly.

2.- INSTALLATION

2.7.-REFRIGERANT CONNECTIONS

The units are supplied with gas and liquid lines sealed with copper covers, and located 60mm from casing

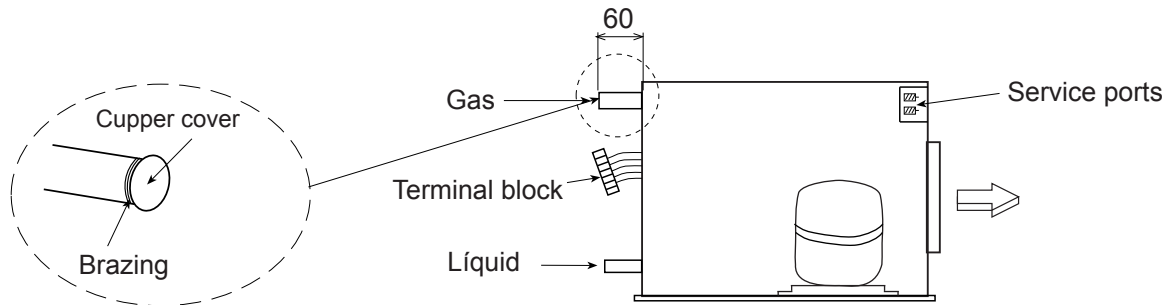

The units are supplied with nitrogen gas, this must be removed and then proceed as follow:

1° Remove the nitrogen gas, through the high and low 1/4" service ports locate inside, from both indoor and outdoor units.

2^a Remove the covers from connecting lines.

3^a Braze the piping connection lines. Refer to installation manual to select the diameter of the lines. (When brazing refrigerant pipes, is necessary to supply nitrogen gas through the service ports into the pipes to remove the air)

4° Leak test:

- Add nitrogen gas and check 5 kg/cm² pressure has been reached, and verify there are not leaks in the circuit or brazing, applying soapy water on pipes, because the leaks cause soapy water to form bubbles. □

To detect small leaks proceed as follow:

Add nitrogen gas and check 32 kg/cm² pressure has been reached, there is not leak if pressure remain the same at least during 24 hours and final pressure is not less than 10% from the initial pressure.

5° Be sure gas line is isolated

6° Vacuuming.

Remove the nitrogen gas, connect the gauge manifold and vacuum pump to both liquid and gas line, fully open the valve of the gauge manifold and switch on the vacuum pump. Check to make sure the gauge shows a pressure level of -750mm Hg, after a level of -750mm Hg is reached, keep on the vacuum pump at least during an hour.

7° Refrigerant charge

-□ Refer to installation manual to verify amount and type of refrigerant which must be charged, and the total amount to be added must be calculated considering the refrigerant charge of the unit, and also the length and sizes of the refrigerant piping.

-□ Disconnect the vacuum pump and connect to the refrigerant-charging cylinder. Open the charging cylinder and purge the air from the hose at the gauge manifold.

-□ Set up the amount of additional refrigerant on the weighing scale, open the high pressure (liquid) and low pressure side (suction) of the gauge valve to start the process of refrigerant from outdoor unit. If the total amount of refrigerant charge have not been reached, because balance pressure, turn off the high side of the gauge manifold, turn on the unit, and add slowly though low side of the gauge the remain amount of the refrigerant charge needed.

(With R-407C refrigerant, the charging cylinder must be on horizontal position and it is important to charge in liquid state)

Close the sides of gauge valve from service port of the unit, put the covers on service ports. Then the unit is ready to work.



During installation operations, keep gas and liquid pipes covered, in order to prevent humidity and dirt, get into them.

Take special concern about refrigerant pipes are isolated.

2.- INSTALLATION

2.7.-REFRIGERANT CONNECTIONS

To locate the outdoor and the indoor units, refer to the following information:

A,B,C : Unit positions

L : Total length

1 = Gas line

2 = Liquid line

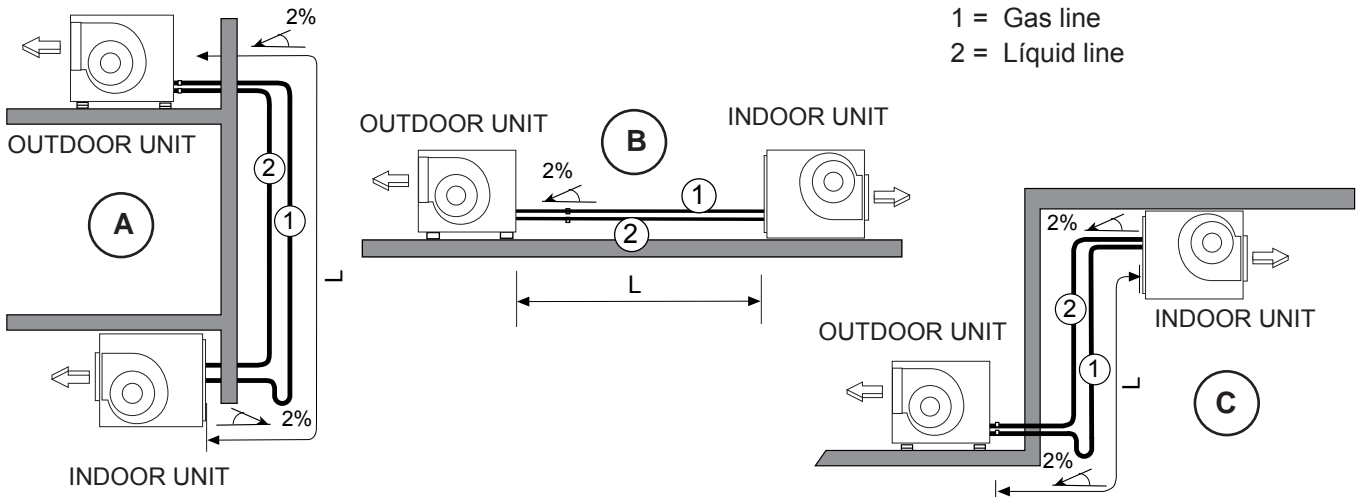

POSITION A : A syphon suction must be installed on the vertical line of the gas line, and syphons must be installed every 8 meters upward.

POSITION B : Tip the lines toward the outdoor unit. Make special attention to line length longer than 10m

POSITION C : Install a syphon at the base of the vertical line, no more syphons are necessary.

TABLE 2: REFRIGERANT LINES SELECTION

REFRIGERANT LINES			UNIT - MODEL						
			10	12	16	22	24	28	30
Total line length	0 to 10 m.	∅ Liquid	3/8"	3/8"	1/2"	5/8"	5/8"	5/8"	5/8"
		∅ Gas	3/4"	3/4"	7/8"	7/8"	11/8"	11/8"	11/8"
	10 to 30 m.	∅ Liquid	3/8"	3/8"	5/8"	5/8"	5/8"	5/8"	3/4"
		∅ Gas	7/8"	7/8"	7/8"	11/8"	11/8"	11/8"	13/8"
	30 to 50 m. 	∅ Liquid	1/2"	1/2"	5/8"	5/8"	3/4"	3/4"	3/4"
		∅ Gas	7/8"	7/8"	11/8"	11/8"	13/8"	13/8"	13/8"
Unit connections		∅ Liquid	3/8"	3/8"	1/2"	5/8"	5/8"	5/8"	5/8"
		∅ Gas	3/4"	3/4"	7/8"	7/8"	11/8"	11/8"	11/8"
Maximum vertical line length (m.)			15	15	15	15	15	15	15
Maximum number of bends			12	12	12	12	12	12	12

- THE GAS LINE ALWAYS MUST BE INSULATED

- THE HORIZONTAL LINES MUST BE TIPPED AT LEAST 2% TOWARD THE OUTDOOR UNIT

- THE MAXIMUM SPEED INSIDE LINES, NOT SHOULD BE MORE THAN 15 m/seg.



For other positions and lines lengths between 30 and 50m or longer , consult the commercial - technical department, the following data will be obtained from that estimation.
Pipe dimensions, Syphon suction, Isolations, Refrigerant load, Line lengths

2.- INSTALLATION

2.7.-REFRIGERANT CONNECTIONS



PRECAUTIONS TO BE TAKEN IN THE USE OF R-407C Refrigerant

If R-407C Refrigerant is used in the unit, the following precautions characteristic of this gas should be taken:

- The Vacuum Pump must have a Check Valve or Solenoid Valve.
- Pressure Gauges and Hoses for the exclusive use with R-407C Refrigerant should be used.
- The charge should be carried out in the Liquid Phase.
- Always use scales to weight-in charge- Use the Leak Detector exclusive for R-407C Refrigerant.
- Do not use mineral oil, only synthetic oil to ream, expand or make connections.
- Keep pipes capped before using them and be very thorough about any possible dirt (dust, filings, burrs, etc.).
- When there is a leak, gather what is left of the charge, create a vacuum in the unit and completely recharge with new R-407C Refrigerant.
- Brazings should always be carried out in a nitrogen atmosphere.
- Reamers should always be well sharpened.

2.- INSTALLATION

2.7.-REFRIGERANT CONNECTIONS

TABLE 3: WEIGHT OF REFRIGERANT PER METER LINE

	FROM 0 TO 10M			FROM 10 TO 30M			FROM 30 TO 50M		
	Suction	Liquid	gr/m	Suction	Liquid	gr/m	Suction	Liquid	gr/m
MODEL 10	3/4"	3/8"	50	7/8"	3/8"	50	7/8"	1/2"	95
MODEL 12	3/4"	3/8"	50	7/8"	3/8"	50	7/8"	1/2"	95
MODEL 16	7/8"	1/2"	95	7/8"	5/8"	150	1-1/8"	5/8"	155
MODEL 22	7/8"	5/8"	150	1-1/8"	5/8"	155	1-1/8"	5/8"	155
MODEL 24	1-1/8"	5/8"	155	1-1/8"	5/8"	155	1-3/8"	3/4"	235
MODEL 28	1-1/8"	5/8"	155	1-1/8"	5/8"	155	1-3/8"	3/4"	235
MODEL 30	1-1/8"	5/8"	155	1-3/8"	3/4"	235	1-3/8"	3/4"	235

TABLE 4: CHARGE OF REFRIGERANT FOR OUTDOOR UNIT + INDOOR UNIT LF

UNIT MODELS		KFHA 10 + LFXO 10	KFHA 12 + LFXO 12	KFHA 16 + LFXO 16	KFHA 22 + LFHA 22	KFHA 24 + LFHA 24	KFHA 28 + LFHA 28	KFHA 30 + LFHA 30
Charge of refrigerant R-22 for 0 meters of line.	gr.	2.900	3.100	3.900	5.400	8.400	8.600	8.700

UNIT MODELS		KFCK 10 + LFXO 10	KFCK 12 + LFXO 12	KFCK 16 + LFXO 16	KFCK 22 + LFCK 22	KFCK 24 + LFCK 24	KFCK 28 + LFCK 28	KFCK 30 + LFCK 30
Charge of refrigerant R-407C for 0 meters of line.	gr.	2.240	2.560	3.550	5.000	---	---	7.000

UNIT MODELS		KFHK 10 + LFXO 10	KFHK 12 + LFXO 12	KFHK 16 + LFXO 16	KFHK 22 + LFHK 22	KFHK 24 + LFHK 24	KFHK 28 + LFHK 28	KFHK 30 + LFHK 30
Charge of refrigerant R-407C for 0 meters of line.	gr.	2.620	2.920	4.000	5.500	7.500	8.000	8.200

CHARGE OF REFRIGERANT FOR THE SET:

EXAMPLE:

To install a KFHK 16 + LFXO 16 set, with a 22m refrigerant line length between outdoor and indoor unit, then the refrigerant charge must be calculated as follow:

1° Type of refrigerant R-22 or R-407C, in this case, R-407C .

2° The TABLE 2 shows, that for 22m of line length between indoor unit and outdoor unit, the line sizes are, liquid 5/8", and gas 7/8".

3° TABLE 3 shows, for line sizes of 5/8"-7/8", the charge per meter line is: 150 gr/m.

4° TABLE 4 shows, charge of refrigerant for the set with 0m of line length is 4000gr.

5° To determinate the charge of the set:

Add charge of the refrigerant lines + charge of refrigerant indoor unit and outdoor unit

$$\text{Total charge for the set: } (150 \text{ gr/m}) \times 22\text{m} + 4.000 \text{ gr} = 4.300 \text{ gr}$$

2.- INSTALLATION

2.8.- ELECTRICAL CONNECTION



- BEFORE MAKING ANY ELECTRICAL CONNECTIONS, BE SURE THAT ALL CIRCUIT BREAKERS ARE OPEN.
- IN ORDER TO CARRY OUT THE ELECTRICAL CONNECTIONS, FOLLOW THE ELECTRICAL DIAGRAM SUPPLIED WITH THE UNIT.

- ① Power Supply
- ② Connection indoor-outdoor unit
- ③ Electrical heater power supply
- ④ Connection to the Control Panel.

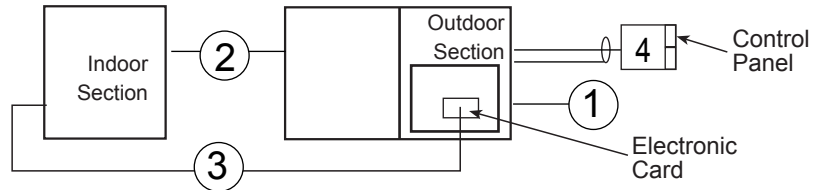
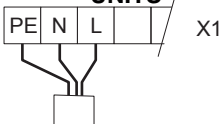
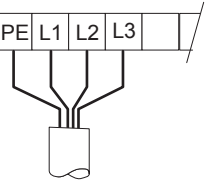
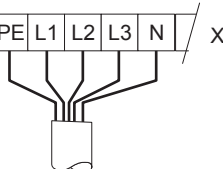

TABLE 6: CABLES SELECTION

POWER SUPPLY 230V SINGLE PHASE UNITS  1N ~ 230V - 50 Hz + PE	UNIT MODEL	No. OF CABLES x SECTION (mm ²)				
		① Power supply WITHOUT electrical heater.	① Power supply WITH electrical heater.	② Connection outdoor-indoor unit WITHOUT electrical heater.	③ Electrical heater power supply	④ Shielded Cable
	10	3 x 4	3 x 16	5 x 1,5	3 x 4 + 2 x 1	2 x 1

POWER SUPPLY 230V THREE-PHASE UNITS  3 ~ 230V - 50 Hz + PE	UNIT MODEL	No. OF CABLES x SECTION (mm ²)				
		① Power supply WITHOUT electrical heater.	① Power supply WITH electrical heater.	② Connection outdoor-indoor unit WITHOUT electrical heater.	③ Electrical heater power supply	④ Shielded Cable
	10	4 x 4	4 x 10	5 x 1,5	4 x 4 + 2 x 1	2 x 1
	12	4 x 4	4 x 10	5 x 1,5	4 x 4 + 2 x 1	2 x 1
	16	4 x 6	4 x 16	4 x 2,5 + 2 x 1	4 x 4 + 2 x 1	2 x 1
	22	4 x 10	4 x 16	4 x 2,5 + 2 x 1	4 x 4 + 2 x 1	2 x 1
	24	4 x 10	4 x 25	4 x 2,5 + 2 x 1	4 x 4 + 2 x 1	2 x 1
	28	4 x 10	4 x 25	4 x 2,5 + 2 x 1	4 x 4 + 2 x 1	2 x 1
	30	4 x 16	4 x 25	4 x 2,5 + 2 x 1	4 x 4 + 2 x 1	2 x 1

POWER SUPPLY 400V THREE- PHASE UNITS  3N ~ 400V - 50 Hz + PE	UNIT MODEL	No. OF CABLES x SECTION (mm ²)				
		① Power supply WITHOUT electrical heater.	① Power supply WITH electrical heater.	② Connection outdoor-indoor unit WITHOUT electrical heater.	③ Electrical heater power supply	④ Shielded Cable
	10	5 x 2,5	5 x 4	5 x 1,5	4 x 1,5 + 2 x 1	2 x 1
	12	5 x 2,5	5 x 4	5 x 1,5	4 x 1,5 + 2 x 1	2 x 1
	16	5 x 4	5 x 6	4 x 1,5 + 2 x 1	4 x 1,5 + 2 x 1	2 x 1
	22	5 x 4	5 x 10	4 x 1,5 + 2 x 1	4 x 1,5 + 2 x 1	2 x 1
	24	5 x 4	5 x 10	4 x 1,5 + 2 x 1	4 x 1,5 + 2 x 1	2 x 1
	28	5 x 4	5 x 10	4 x 1,5 + 2 x 1	4 x 1,5 + 2 x 1	2 x 1
	30	5 x 6	5 x 10	4 x 1,5 + 2 x 1	4 x 1,5 + 2 x 1	2 x 1

(*) To install with LFXO, LFC, LFH indoor unit, and without electrical heater

- The sections have been calculated for a length no longer than 50m and a voltage drop of 10V. Do not start the unit if the drop is greater than this.

2.- INSTALLATION

2.8- ELECTRICAL CONNECTION

VOLTAGE OPERATING LIMITS

MODELS	VOLTAGE	LIMIT
10	230V-1Ph-50Hz	198-264V -1Ph- 50Hz
10-12-16-22	230V-3Ph-50Hz	180-242V -3Ph- 50Hz
	400V-3Ph-50Hz	342-462V -3Ph- 50Hz
24-28-30	230V-3Ph-50Hz	198-264V -3Ph- 50Hz
	400V-3Ph-50Hz	342-462V -3Ph- 50Hz

- Connect the power supply cables to the terminals in the electric box through the rubber grommet.
- The wiring and circuit breakers to be mounted in the installation must comply with the Regulations in force.
- Ground wires must be properly connected and have a greater length than the phase wires.



IMPORTANT

THE SHIELDED CONNECTION CABLE BETWEEN THE CONTROL PANEL AND THE UNIT MUST BE SEPARATE FROM ANY OTHER TYPE OF ELECTRICAL WIRING. CONNECT IT TO THE ELECTRIC BOX LOCATED IN THE OUTDOOR UNIT.

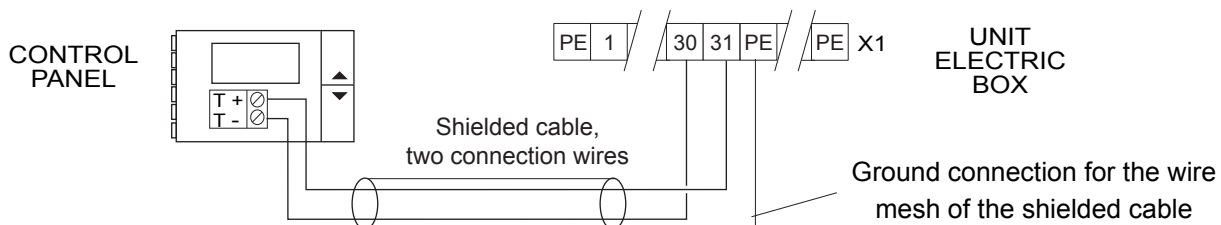

- For securing and connecting the Control Panel, consult the control Panel Manual supplied with the unit.
- Keep in mind that the Control Panel cable is a SHIELDED CABLE and the wire mesh is only grounded on the electric box side.
- The T+ and T- polarity must strictly agree with the electrical diagram supplied with the unit.



Since this type of control panel is factory-configured for each application, an identification code located on the control panel of the terminal itself has been given to each panel. Any query or request for a replacement of the control panel must be accompanied by this identification code.

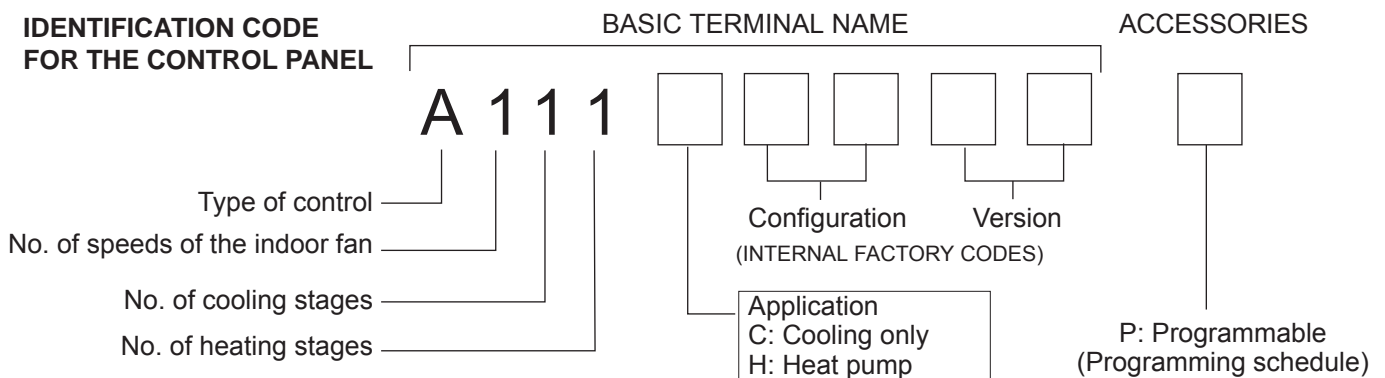

3.- COMMISSIONING AND OPERATION

3.1.- PRELIMINARY CHECKS

- ① Check that drain pipe connections and their fixtures are secure and that the level of the unit is tipped toward the drain.
- ② Inspect the state of the ducts and grilles (clean and open grilles, no breaks in the duct, etc.).
- ③ Check that the power supply is the same as stated on the Rating Plate which is in agreement with the electrical diagram for the unit and that cable sizes are correct.
Check that tightness of the electrical connections to their terminals and to ground.
- ④ Check the control panel connections.
(If the connection is wrong, the unit will not operate and the control panel display will not light).
- ⑤ Check **with your hand** that the fans turn freely.

FIGURE FOR THE STANDARD UNIT CONFIGURATION FOR MODELS 24-28-30

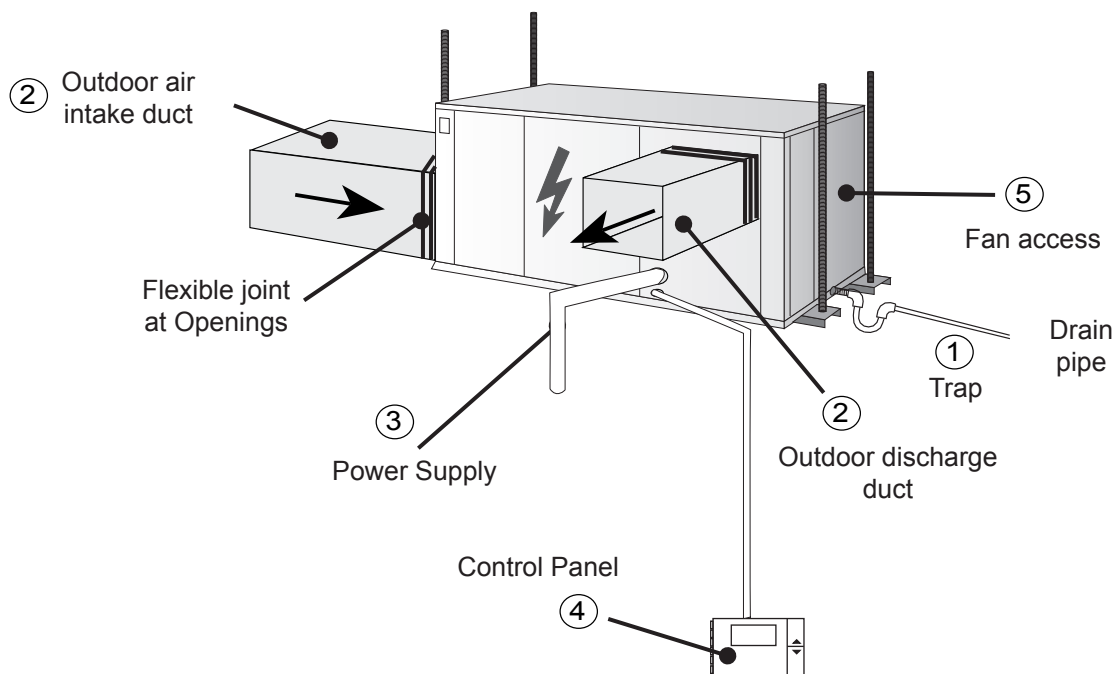

Close the unit and check that there are no loose panels.

3.- COMMISSIONING AND OPERATION

3.2.- STEPS TO FOLLOW FOR COMMISSIONING THE UNITS

- On the heat pump units, the compressor has a single phase electric heating element to assure a separation between the Refrigerant and the oil in the housing. This heater is activated when the compressor is off and stops working when the compressor is on.
About eight hours before start up or after a long shutdown period, voltage should be supplied to the unit so that this heater will be activated.
- To start the unit, follow the instructions given in the Control Panel Manual supplied with the unit (requesting operation in any of the modes, cooling, heating, or automatic).
After a time lapse, the unit will start.
- With unit operating, check that the fans are turning freely and in the proper direction.



REMEMBER THAT THE COMPRESSOR IS A SCROLL TYPE COMPRESSOR:

Scroll type compressors only compress in one direction of the rotation. Single phase models are always started up in the proper direction; however, the three phase models, turn in either direction depending on the order of the power supply phases. Therefore, it is essential that the phase connection for scroll-type three-phase compressors be carried out correctly (the correct direction of rotation can be checked when the pressure on the suction side decreases and the pressure on the discharge side increases when the compressor is activated). If the connection is wrong, the rotation will be reversed causing a high noise level and a reduction in the amount of current consumed. If this occurs, the compressor's internal protection system will kick in shutting down the unit. The solution is to disconnect, switch the wires between two of the phases and connect again).

- Check compressor oil level, sight glass included (on the sides of the compressor, the level should be between 1/4 and 3/4 in the sight glass, while during operation the level should be between 3/4 and full).
- Connect high and low pressure gauges and check that operating pressure values are normal.
- Measure electrical consumption for the unit and check that it is near what is indicated on the Rating Plate.
- Check the electrical consumption of the compressor and the fans with what is specified in the physical data sheets.
- In the case of a Heat Pump unit, make a cycle change on the Control Panel checking that the 4-way valves make the change correctly. Check the pressure values in the new cycle.
- **Remember the low pressure switch is reset automatically and the high pressure switch is reset electronically.**
- Check that pressure switches stop the unit:

FOR THE COOLING CYCLE UNIT:

Stop the outdoor fan by disconnecting it. The high pressure should rise and the pressure switch should stop the compressor at 27.5 kg/cm^2 . Reconnect the fan and electrically reset the pressure switch by pressing the "RESUME" button on the Control Panel for 5 seconds and wait for the anti-cycle time (5 minutes), afterwards, the unit will start-up again.

Stop the indoor fan by disconnecting it. The low pressure should drop and the unit should stop when the pressure gauge reaches 1 kg/cm^2 . The unit will start up again when the pressure rises and the pressure gauge indicates 2 kg/cm^2 . Once this has been carried out, stop the unit and reconnect the fan.

- Start the unit again and when everything is operating normally, take a reading of all the data and **fill out the Commissioning Sheet.**

4.- MAINTENANCE

4.1.- PREVENTIVE MAINTENANCE



PREVENTIVE MAINTENANCE PREVENTS COSTLY REPAIRS.
BECAUSE OF THIS PERIODIC INSPECTIONS ARE REQUIRED.

-GENERAL STATE OF THE CASING :

Furniture, paint, deterioration due to bumps, rust spots, leveling and supporting, state of the shock absorbers, if installed, screwed panels, etc.

- ELECTRICAL CONNECTIONS :

State of hoses, tightness of screws, grounding, current draw of the compressor and fans and checking that the unit is receiving the correct voltage.

- COOLING CIRCUIT :

Check that pressure values are correct and that there are no leaks. Check that there is no damage to the pipe insulation, that the state of the batteries is correct and that there are no chips or clogs retained by the air flow, etc.

- COMPRESSOR :

Inspect the oil level, if sight glass is present.
Inspect the state of the silent block fixtures.

- DRAINS :

Check that water drains correctly and that the drain trays are clean.

- FANS :

Check that fans turn freely and in the correct direction without excessive noises.

- CONTROL :

Check Set Points and normal operation.

4.- MAINTENANCE

4.2.- CORRECTIVE MAINTENANCE



IMPORTANT

MAKE SURE THAT THE UNIT IS COMPLETELY DISCONNECTED FROM THE POWER SUPPLY WHEN CARRYING OUT ANY TYPE OF WORK ON THE MACHINE

If some component in the cooling circuit must be replaced, follow these recommendations:

- Always use original replacement parts.
- Remove the entire refrigerant charge from the unit from through the schrader valves located in the outdoor section. Create a slight vacuum as a safety measure.
- Regulation prohibits the release on the refrigerant into the atmosphere.
- If cuts must be made in the pipework, use pipe cutters. Do not use saws or any other tools that produce filings.
- All brazing must be carried out in a nitrogen atmosphere to prevent corrosion from forming.
- Use silver alloy brazing rod.
- Take special care that the flame from the torch is aimed in the opposite direction from the component to be welded and is covered with a wet rag in order to avoid overheating.

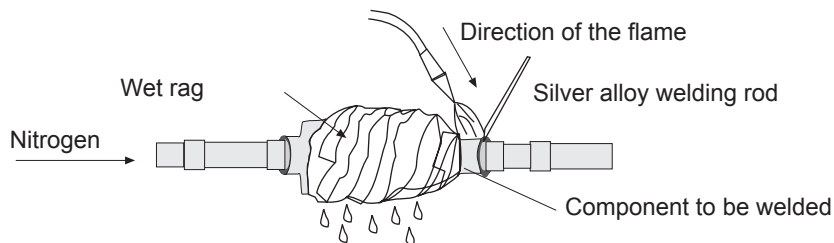

- Take very special care if 4-way check valves are to be replaced since these have internal components that are very heat-sensitive such as plastic, teflon, etc.
- If a compressor must be replaced, disconnect it electrically and un-braze the suction and discharge lines. Remove the securing screws and replace the old compressor with the new one. Check that the new compressor has the correct oil charge, screw it to the base and connect the lines and electrical connections.
- Carry out the vacuum above and below through the schrader valves of the outdoor unit until -750 mm Hg is reached.
Once this level of vacuum has been reached, keep the pump in operation for at least one hour. **DO NOT USE THE COMPRESSOR AS A VACUUM PUMP.**
- Charge the unit with refrigerant according to the data on the Rating Plate for the unit and **check that there are no leaks.**



PRECAUTIONS TO BE TAKEN IN THE USE OF R-407C Refrigerant

If R-407C Refrigerant is used in the unit, the following precautions characteristic of this gas should be taken:

- The Vacuum Pump must have a Check Valve or Solenoid Valve.
- Pressure Gauges and Hoses for the exclusive use with R-407C Refrigerant should be used.
- The charge should be carried out in the Liquid Phase.
- Always use scales to weight-in charge- Use the Leak Detector exclusive for R-407C Refrigerant.
- Do not use mineral oil, nonly ynthetic oil to ream, expand or make connections.
- Keep pipes w capped before using them and be very thorough about any possible dirt (dust, filings, burrs, etc.).
- When there is a leak, gather what is left of the charge, create a vacuum in the unit and completely recharge with new R-407C Refrigerant.
- WBrazings should always be carried out in a nitrogen atmosphere.
- Reamers should always be well sharpened.

4.- MAINTENANCE

4.3.- FAILURE DIAGNOSIS

In case of failure or malfunction of the unit, the Display on the Control Panel will show an Error or Alarm warning explained in the Control Panel Manual. Nevertheless, whenever there is a unit failure, the unit should be shut down and our Service Technicians consulted.

FAILURE	POSSIBLE CAUSES	POSSIBLE SOLUTIONS
UNIT DOES NOT START	Failure in the power supply, or insufficient voltage.	Connect the power supply or check the voltage.
	Circuit breakers have opened.	Reset.
	Power cable or Control Panel cable is defective.	Inspect and Correct.
UNIT STOPS DUE TO HIGH PRESSURE DURING THE COOLING CYCLE	High Pressure switch is defective.	Check Cut-off Pressure or change Pressure Switch if necessary.
	Fan is not working.	Check for voltage, inspect the motor and turbine or replace if necessary.
	Fan turns in the wrong direction.	Switch the power phases.
	Coil is dirty or clogged for passing air	Inspect and Clean.
	Excess charge of the Refrigerant.	Remove the charge and charge according to the data on the Rating Plate.
UNIT STOPS DUE TO LOW PRESSURE	Low pressure switch defective.	Check the Cut-off Pressure with a pressure gauge and change the Pressure switch if necessary.
	Lack of refrigerant. Leak.	Correct leak, create vacuum and charge.
	Clogged Cooling Circuit. Dirty filter drier.	Inspect and Correct or Change the Filter drier.
UNIT STARTS AND STOPS IN SHORT CYCLES	Compressor overcharged.	Inspect suction and discharge pressure values and correct.
	Compressor cuts off due to Klixon.	Inspect input voltage and voltage drop.
	Lack of Refrigerant.	Correct leak and replace.
LOAD AND ABNORMAL NOISE IN THE COMPRESSOR (SCROLL)	Power supply phases inverted (three-phase compressor).	Inspect and switch power phases.
WATER LEAKS	Clogged drainage.	Inspect and Clean.
	Loose drainage pipe connections.	Correct connection.
	Dirty and overflowing trays.	Inspect and Clean.

A series of 25 horizontal lines, evenly spaced, spanning most of the page width, intended for writing or drawing.

