



Installation, operating and maintenance

COMPACTAIR/AIRCOOLAIR - LECK/LEHK



- Providing indoor climate comfort

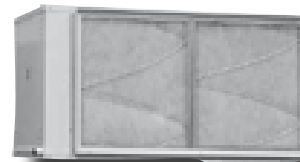

WARNING: Read this manual before installation, repair or maintenance works.

TABLE OF CONTENTS

POINTS TO KEEP IN MIND	PAGE 2
DATA PAGE FOR UNIT COMMISSIONING	PAGE 3
1.- GENERAL CHARACTERISTICS	PAGE
1.1.- PHYSICAL DATA	4
1.2.- ELECTRICAL DATA	4-5
1.3.- FAN PERFORMANCES	6-7
1.4.- UNIT DIMENSIONS	8-9
1.5.- AVAILABLE OPTIONS	10-22
2.- INSTALLATION	PAGE
2.1.- INSTALLATION GUIDELINES	23
2.2.- OPTIONAL TASK PRIOR TO UNIT INSTALLATION: CHANGING THE POSITION OF DISCHARGE AND AIR INTAKE	23
2.3.- OPTIONAL TASK PRIOR TO UNIT INSTALLATION: FLOW REGULATION IN THE FANS	24
2.4.- INSTALLATION CLEARANCES	24
2.5.- DRAINS	24
2.6.- REFRIGERANT CONNECTIONS	25
2.7.- ELECTRICAL CONNECTIONS	25
3.- COMMISSIONING AND OPERATION	PAGE
3.1.- PRELIMINARY CHECKS	26
4.- MAINTENANCE	PAGE
4.1.- PREVENTIVE MAINTENANCE	26

Lennox have been providing environmental solutions since 1895, our range of **COMPACTAIR / AIRCOOLAIR** continues to meet the standards that have made **LENNOX** a household name. Flexible design solutions to meet **YOUR** needs and uncompromising attention to detail. Engineered to last, simple to maintain and Quality that comes as standard. Information on local contacts at www.lennox europe.com.

All the technical and technological information contained in this manual, including any drawing and technical descriptions provided by us, remain the property of Lennox and must not be utilised (except in the operation of this product), reproduced, issued to or made available to third parties without the prior written agreement of Lennox.

POINTS TO KEEP IN MIND

DANGER AND WARNING SIGNS



Abrasive surfaces



Low temperatures



High temperatures

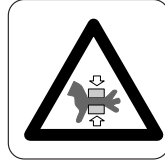

Risk of injury with moving objects

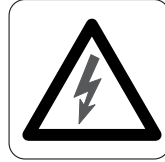

Electrical voltage



Risk of injury with rotating objects

ELECTRICAL CONNECTIONS



Make sure to open the power off switch before to install, repair or make maintenance works in the unit, in order to prevent serious electrical injuries.

To install the unit, keep in mind local and national legislation.

ATTENTION - WARNING

Electric shock hazard can cause injury or death. Before attempting to perform any service or maintenance on the unit, turn OFF the electrical power, and check that the fan has stopped.

The air filter cleaning operations do not require technical service; however when an electrical or mechanical operation is required call an Engineer.

FILTER CLEANING

Check the air filter and make sure it is not blocked with dust or dirt.

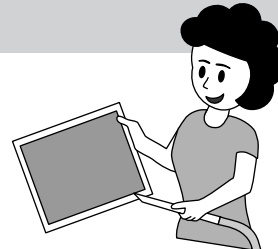
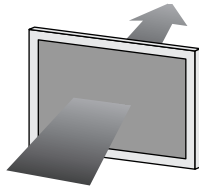

If the filter is dirty, wash it in a bowl with neutral soap and water, drying it in the shade before inserting it in the unit.

Standard Guidelines to Lennox equipment

All technical data contained in these operating instructions including the diagrams and technical description remains the property of Lennox and may not be used (except for the purpose of familiarizing the user with the equipment), reproduced, photocopied, transferred or transmitted to third parties without prior written authorization from Lennox .

The data published in the operating instructions is based on the latest information available. We reserve the right to make modifications without notice.

We reserve the right to modify our products without notice without obligation to modify previously supplied goods.

These operating instructions contain useful and important information for the smooth operation and maintenance of your equipment.

The instructions also include guidelines on how to avoid accidents and serious damage before commissioning the equipment and during its operation and how to ensure smooth and fault-free operation. Read the operating instructions carefully before starting the equipment, familiarize yourself with the equipment and handling of the installation and carefully follow the instructions. It is very important to be properly trained in handling the equipment. These operating instructions must be kept in a safe place near the equipment.

Like most equipment, the unit requires regular maintenance. This section concerns the maintenance personnel and management. If you have any queries or would like to receive further information on any aspect relating to your equipment, do not hesitate to contact us.

DATA PAGE FOR UNIT COMMISSIONING

UNIT: _____ SERIAL Nr.: _____

CONTROL PANEL IDENTIFICATION CODE _____

INSTALLATION ADDRESS: _____

INSTALLER: _____ INSTALLER TEL.: _____

INSTALLER ADDRESS: _____

DATE OF COMMISSIONING: _____

CHECKS:

SUPPLY VOLTAGE: _____ RATED VOLTAGE OF THE UNIT: _____

	YES	NO
DRAINAGE WITH TRAP	<input type="checkbox"/>	<input type="checkbox"/>
CLEAN INTERIOR AIR FILTER	<input type="checkbox"/>	<input type="checkbox"/>
GENERAL POWER SUPPLY CONNECTION	<input type="checkbox"/>	<input type="checkbox"/>

DATA INPUT:

COLD CYCLE

Air Intake Temperature, Indoor Coil: _____ °C

High Pressure: _____

Low Pressure: _____

HEATING CYCLE

Air Intake Temperature, Indoor Coil: _____ °C

High Pressure: _____

Low Pressure: _____

ELECTRIC POWER CONSUMPTION (Amps)

Fan indoor section ____/____/____

Fan indoor section ____/____/____

Options Installed: _____

Comments: _____

1.- GENERAL CHARACTERISTICS

1.1.- PHYSICAL DATA

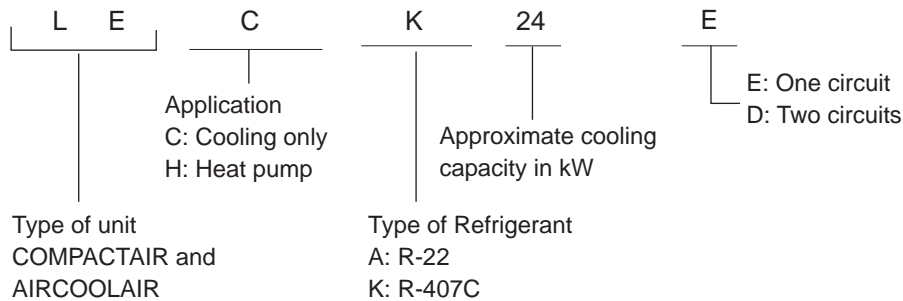

LEHA: Heat pump unit R-22
 LECK: Cooling only unit R-407C
 LEHK: Heat pump unit R-407C

UNIT MODELS	22E	24E	28E	32E	38E	43E	50E	56E	76E
NET WEIGHT	105	105	110	110	145	280	305	275	295

UNIT MODELS	44D	48D	56D	64D	76D	86D	100D	112D	128D	152D
NET WEIGHT	220	220	240	240	265	270	295	510	520	530

1.2.- ELECTRICAL DATA

ELECTRICAL CONSUMPTION FOR STANDARD UNITS.

UNIT MODELS	LECK 22E	LECK 24E	LECK 28E	LECK 32E	LECK 38E	LECK 43E	LECK 50E	LECK 56E	LECK 76E
	LEHK 22E	LEHK 24E	LEHK 28E	LEHK 32E	LEHK 38E	LEHK 43E	LEHK 50E	LEHK 56E	LEHK 76E
Voltage V/f (50 Hz)	230V/400V+N-3Ph							400V+N-3Ph	
Maximum absorbed power kW	1,3	1,4	1,5	1,8	2,0	2,5	2,8	3,0	3,0
Maximum current A	4,3/2,5	4,3/2,5	6,2/3,6	6,2/3,6	6,2/3,6	10,3/6	10,3/6	7,2	7,2
Start up current A	20,4/11,8	20,4/11,8	32,5/18,8	32,5/18,8	32,5/18,8	65,5/38,0	65,5/38,0	22,3	22,3

UNIT MODELS	LECK 44D	LECK 48D	LECK 56D	LECK 64D	LECK 76D	LECK 86D	LECK 100D	LECK 112D	LECK 128D	LECK 152D
	LEHK 44D	LEHK 48D	LEHK 56D	LEHK 64D	LEHK 76D	LEHK 86D	LEHK 100D	LEHK 112D	LEHK 128D	LEHK 152D
Voltage V/f (50 Hz)	230V/400V+N-3Ph							400V+N-3Ph		
Maximum absorbed power kW	2,6	2,8	3,0	3,6	4,0	5,0	5,5	5,5	5,5	5,5
Maximum current A	8,8/5,1	8,8/5,1	12,5/7,2	12,5/7,2	12,5/7,2	20,6/11,9	20,6/11,9	11,9	11,9	11,9
Start up current A	46,7/27,0	46,7/27,0	64,7/37,4	64,7/37,4	64,7/37,4	131/76,0	131/76,0	76,0	76,0	76,0

1.- GENERAL CHARACTERISTICS

1.2.- ELECTRICAL DATA

ADDITIONAL ELECTRICAL CONSUMPTION FOR THE OPTIONS

ELECTRICAL HEATER		LECK 22E-24E-28E-32E-38E			LECK 43E-50E		LECK 56E		LECK 76E		
Voltage	V/f (50 Hz)	230V/400V+N-3Ph					400V+N-3Ph				
Maximum absorbed power	kW	7,5	11	15	11	15	15	20	20	30	
Maximum current	A	18,8/10,8	27,6/15,9	37,7/21,7	27,6/15,9	37,7/21,7	21,7	28,9	28,9	43,3	

ELECTRICAL HEATER		LECK 44D-48D-56D-64D-76D				LECK 86D-100D			LECK 112D-128D-152D		
Voltage	V/f (50 Hz)	230V/400V+N-3Ph							400V+N-3Ph		
Maximum absorbed power	kW	11	15	20	30	15	22,5	30	40	60	
Maximum current	A	27,6/15,9	37,7/21,7	50,2/28,9	75,3/43,3	37,7/21,7	56,5/32,5	75,3/43,3	57,7	86,6	

ELECTRICAL HEATER		LEHK/LEHA 22E-24E-28E-32E-38E-43E-50E			LEHK 56E-76E		
Voltage	V/f (50 Hz)	230V/400V+N-3Ph			400V+N-3Ph		
Maximum absorbed power	kW	7,5	11	15	15	20	
Maximum current	A	18,8/10,8	27,6/15,9	37,7/21,7	21,7	28,9	

ELECTRICAL HEATER		LEHK/LEHA 44D-48D-56D-64D-76D			LEHK/LEHA 86D-100D		LEHK 112D-128D-152D		
Voltage	V/f (50 Hz)	230V/400V+N-3Ph						400V+N-3Ph	
Maximum absorbed power	kW	11	15	20	15	22,5	30	40	
Maximum current	A	27,6/15,9	37,7/21,7	50,2/28,9	37,7/21,7	56,5/32,5	43,3	57,7	

EXHAUST FAN		LECK 56E LEHK 56E	LECK 76E LEHK 76E	LECK 112D LEHK 112D	LECK 128D LEHK 128D	LECK 152D LEHK 152D
Voltage	V/f (50 Hz)	400V+N-3Ph				
Maximum absorbed power	kW	2,65	2,65	5,3	5,3	5,3
Maximum current	A	4,5	4,5	9	9	9

HIGH PRESSURE FAN		LECK 22E LEHK 22E LEHA 22E	LECK 24E LEHK 24E LEHA 24E	LECK 28E LEHK 28E LEHA 28E	LECK 32E LEHK 32E LEHA 32E	LECK 38E LEHK 38E LEHA 38E	LECK 43E LEHK 43E LEHA 43E	LECK 50E LEHK 50E LEHA 50E	LECK LEHK 56E	LECK LEHK 76E	
Voltage	V/f (50 Hz)	230V/400V+N-3Ph							400V+N-3Ph		
Maximum absorbed power	kW	0,2	0,4	0,8	1	1	0,8	0,8	1	1	
Maximum current	A	0,5/0,3	1,0/0,6	2,0/1,2	2,5/1,4	2,5/1,4	2,0/1,2	2,0/1,2	1,45	1,45	

HIGH PRESSURE FAN		LECK 44D LEHK 44D LEHA 44D	LECK 48D LEHK 48D LEHA 48D	LECK 56D LEHK 56D LEHA 56D	LECK 64D LEHK 64D LEHA 64D	LECK 76D LEHK 76D LEHA 76D	LECK 86D LEHK 86D LEHA 86D	LECK 100D LEHK 100D LEHA 100D	LECK LEHK 112D	LECK LEHK 128D	LECK LEHK 152D	
Voltage	V/f (50 Hz)	230V/400V+N-3Ph							400V+N-3Ph			
Maximum absorbed power	kW	0,4	0,8	1,5	1,5	1,7	1,5	1,5	2	2	2	
Maximum current	A	1,0/0,6	2,0/1,2	3,8/2,2	3,8/2,2	4,3/2,5	3,8/2,2	3,8/2,2	2,9	2,9	2,9	

RETURN FAN		LECK 22E LEHK 22E LEHA 22E	LECK 24E LEHK 24E LEHA 24E	LECK 28E LEHK 28E LEHA 28E	LECK 32E LEHK 32E LEHA 32E	LECK 38E LEHK 38E LEHA 38E	LECK 43E LEHK 43E LEHA 43E	LECK 50E LEHK 50E LEHA 50E	LECK LEHK 56E	LECK LEHK 76E	
Voltage	V/f (50 Hz)	230V/400V+N-3Ph							400V+N-3Ph		
Maximum absorbed power	kW	1,3	1,4	1,5	1,8	2	2,5	2,8	3	3	
Maximum current	A	4,3/2,5	4,3/2,5	6,2/3,6	6,2/3,6	6,2/3,6	10,3/6	10,3/6	7,2	7,2	

RETURN FAN		LECK 44D LEHK 44D LEHA 44D	LECK 48D LEHK 48D LEHA 48D	LECK 56D LEHK 56D LEHA 56D	LECK 64D LEHK 64D LEHA 64D	LECK 76D LEHK 76D LEHA 76D	LECK 86D LEHK 86D LEHA 86D	LECK 100D LEHK 100D LEHA 100D	LECK LEHK 112D	LECK LEHK 128D	LECK LEHK 152D	
Voltage	V/f (50 Hz)	230V/400V+N-3Ph							400V+N-3Ph			
Maximum absorbed power	kW	2,6	2,8	3	3,6	4	5	5,5	5,5	5,5	5,5	
Maximum current	A	8,8/5,1	8,8/5,1	12,5/7,2	12,5/7,2	12,5/7,2	20,6/11,9	20,6/11,9	11,9	11,9	11,9	

1.- GENERAL CHARACTERISTICS

1.3.- STANDARD FAN PERFORMANCES

		22E					24E					28E							
AIR FLOW		R.P.M.	M ³ /H	3500	3900	4300	4700	R.P.M.	M ³ /H	3900	4300	4700	5100	R.P.M.	M ³ /H	4500	4950	5400	5850
PULLEY POSITION	PULLEY CLOSED	890	205*	195*	165*	130*	890	195*	165*	130*	85*	1010	250*	200*	95*	30*			
	1 TURN	840	165*	150*	125*	90*	840	150*	125*	90*	50*	955	190*	145*	40*	—			
	2 TURNS	790	130*	115*	90*	55*	790	115*	90*	55*	15*	900	145*	100*	0*	—			
	3 TURNS	740	105*	80*	60*	20*	740	80*	60*	20*	—	845	105*	55*	—	—			
		32E					38E					43E							
AIR FLOW		R.P.M.	M ³ /H	4750	5250	5750	6000	R.P.M.	M ³ /H	5800	6400	7000	7300	R.P.M.	M ³ /H	6500	7250	8000	8750
PULLEY POSITION	PULLEY CLOSED	1010	220*	175*	115*	70*	1010	240*	200*	●	●	1075	290*	245*	185*	135*			
	1 TURN	955	165*	115*	50*	0*	955	190*	150*	100*	●	1010	235*	185*	125*	95*			
	2 TURNS	900	125*	65*	0*	—	900	150*	110*	65*	40*	940	180*	125*	60*	0*			
	3 TURNS	845	80*	25*	—	—	845	105*	60*	15*	0*	870	140*	85*	20*	—			
		50E					56E					76E							
AIR FLOW		R.P.M.	M ³ /H	7250	8000	8750	9000	R.P.M.	M ³ /H	9000	10000	11000	11250	R.P.M.	M ³ /H	10000	11000	12000	12500
PULLEY POSITION	PULLEY CLOSED	1140	300*	245*	185*	●	800	375*	355*	330*	320*	800	355*	330*	285*	●			
	1 TURN	1070	230*	170*	100*	75*	770	350*	330*	285*	275*	770	330*	285*	255*	●			
	2 TURNS	995	150*	105*	35*	10*	735	300*	285*	235*	225*	735	285*	235*	205*	180*			
	3 TURNS	920	70*	35*	—	—	700	255*	235*	190*	180*	700	235*	190*	160*	140*			
		44D					48D					56D							
AIR FLOW		R.P.M.	M ³ /H	7000	7800	8600	9400	R.P.M.	M ³ /H	7800	8600	9400	10200	R.P.M.	M ³ /H	9000	9900	10800	11700
PULLEY POSITION	PULLEY CLOSED	890	205*	195*	165*	130*	890	195*	165*	130*	85*	1010	250*	200*	95*	30*			
	1 TURN	840	165*	150*	125*	90*	840	150*	125*	90*	50*	955	190*	145*	40*	—			
	2 TURNS	790	130*	115*	90*	55*	790	115*	90*	55*	15*	900	145*	100*	0*	—			
	3 TURNS	740	105*	80*	60*	20*	740	80*	60*	20*	—	845	105*	55*	—	—			
		64D					76D					86D							
AIR FLOW		R.P.M.	M ³ /H	9500	10500	11500	12000	R.P.M.	M ³ /H	11600	12800	14000	14600	R.P.M.	M ³ /H	13000	14500	16000	17500
PULLEY POSITION	PULLEY CLOSED	1010	220*	175*	115*	70*	1140	240*	200*	●	●	1055	270*	225*	165*	115*			
	1 TURN	955	165*	115*	50*	0*	1070	190*	150*	100*	●	1010	235*	185*	125*	95*			
	2 TURNS	900	125*	65*	0*	—	995	150*	110*	65*	40*	965	195*	145*	85*	35*			
	3 TURNS	845	80*	25*	—	—	920	105*	60*	15*	0*	920	160*	110*	45*	—			
		100D					112D					128D/152D							
AIR FLOW		R.P.M.	M ³ /H	14500	16000	17500	18000	R.P.M.	M ³ /H	18000	20000	22000	22500	R.P.M.	M ³ /H	20000	22000	24000	24500
PULLEY POSITION	PULLEY CLOSED	1120	280*	225*	165*	●	800	345*	295*	265*	●	800	345*	295*	265*	●			
	1 TURN	1080	235*	175*	105*	80*	760	315*	270*	235*	●	760	315*	270*	235*	●			
	2 TURNS	1030	195*	135*	65*	30*	715	270*	220*	185*	165*	715	270*	220*	185*	165*			
	3 TURNS	980	145*	90*	20*	0*	680	220*	175*	145*	125*	680	220*	175*	145*	125*			

(*) AVAILABLE STATIC PRESSURE Pa.

(●) WRONG STATUS ON ACCOUNT OF MOTOR POWER LIMIT.

NOTE: The unit leaves factory with pulley 2 turns opened for models 22E to 100D and with pulley 6 turns opened for models 112D to 152D.

NOTE: Additional pressure drop with the option high efficiency air filter-EU4 is 50Pa. (Only for models 56E-76E-112D-128D-152D).

1.- GENERAL CHARACTERISTICS

1.3.- FAN PERFORMANCES WITH KIT HIGH STATIC PRESSURE TO 400 Pa (OPTION)

		22E					24E					28E							
AIR FLOW		R.P.M.	M ³ /H	3500	3900	4300	4700	R.P.M.	M ³ /H	3900	4300	4700	5100	R.P.M.	M ³ /H	4500	4950	5400	5850
PULLEY POSITION	PULLEY CLOSED	1140	420*	405*	385*	360*	1140	405*	385*	360*	●	1200	410*	390*	320*	290*			
	1 TURN	1070	360*	340*	315*	290*	1070	340*	315*	290*	●	1125	340*	305*	240*	210*			
	2 TURNS	995	290*	275*	250*	205*	995	275*	250*	205*	195*	1050	275*	240*	165*	130*			
	3 TURNS	920	240*	215*	190*	160*	920	215*	190*	160*	130*	970	215*	175*	100*	60*			
		32E					38E					43E							
AIR FLOW		R.P.M.	M ³ /H	4750	5250	5750	6000	R.P.M.	M ³ /H	5800	6400	7000	7300	R.P.M.	M ³ /H	6500	7250	8000	8750
PULLEY POSITION	PULLEY CLOSED	1200	400*	365*	300*	270*	1200	400*	385*	●	●	1200	410*	390*	325*	●			
	1 TURN	1125	330*	290*	220*	190*	1125	320*	305*	260*	●	1125	340*	315*	240*	205*			
	2 TURNS	1050	265*	225*	145*	110*	1050	270*	235*	180*	●	1050	270*	245*	165*	130*			
	3 TURNS	970	205*	160*	80*	40*	970	220*	185*	110*	95*	970	215*	185*	105*	60*			
		50E					56E					76E							
AIR FLOW		R.P.M.	M ³ /H	7250	8000	8750	9000	R.P.M.	M ³ /H	9000	10000	11000	11250	R.P.M.	M ³ /H	10000	11000	12000	12500
PULLEY POSITION	PULLEY CLOSED	1200	380*	315*	●	●	895	520*	485*	460*	450*	895	485*	460*	415*	●			
	1 TURN	1125	305*	230*	195*	●	860	460*	440*	400*	390*	860	440*	400*	375*	●			
	2 TURNS	1050	235*	155*	120*	65*	820	395*	375*	340*	330*	820	375*	340*	290*	280*			
	3 TURNS	970	175*	95*	50*	—	780	355*	320*	275*	245*	780	320*	275*	245*	225*			
		44D					48D					56D							
AIR FLOW		R.P.M.	M ³ /H	7000	7800	8600	9400	R.P.M.	M ³ /H	7800	8600	9400	10200	R.P.M.	M ³ /H	9000	9900	10800	11700
PULLEY POSITION	PULLEY CLOSED	1140	420*	405*	385*	360*	1140	405*	385*	360*	●	1200	410*	390*	320*	290*			
	1 TURN	1070	360*	340*	315*	290*	1070	340*	315*	290*	●	1125	340*	305*	240*	210*			
	2 TURNS	995	290*	275*	250*	205*	995	275*	250*	205*	195*	1050	275*	240*	165*	130*			
	3 TURNS	920	240*	215*	190*	160*	920	215*	190*	160*	130*	970	215*	175*	100*	60*			
		64D					76D					86D							
AIR FLOW		R.P.M.	M ³ /H	9500	10500	11500	12000	R.P.M.	M ³ /H	11600	12800	14000	14600	R.P.M.	M ³ /H	13000	14500	16000	17500
PULLEY POSITION	PULLEY CLOSED	1200	400*	365*	300*	●	1200	400*	385*	●	●	1200	410*	390*	●	●			
	1 TURN	1125	330*	290*	220*	190*	1125	320*	305*	260*	●	1150	365*	345*	265*	●			
	2 TURNS	1050	265*	225*	145*	110*	1050	270*	235*	180*	●	1100	315*	295*	215*	●			
	3 TURNS	970	205*	160*	80*	40*	970	220*	185*	110*	95*	1050	270*	245*	165*	130*			
		100D					112D					128D/152D							
AIR FLOW		R.P.M.	M ³ /H	14500	16000	17500	18000	R.P.M.	M ³ /H	18000	20000	22000	22500	R.P.M.	M ³ /H	20000	22000	24000	24500
PULLEY POSITION	PULLEY CLOSED	1200	380*	315*	●	●	2 TURNS	870	485*	460*	420*	410*	870	460*	420*	395*	●		
	1 TURN	1150	335*	255*	●	●	4 TURNS	835	435*	410*	380*	370*	835	410*	380*	340*	●		
	2 TURNS	1100	285*	205*	●	●	6 TURNS	800	390*	365*	340*	330*	800	365*	340*	290*	270*		
	3 TURNS	1050	235*	155*	120*	●	7 TURNS	760	350*	330*	285*	275*	760	330*	285*	255*	235*		

(*) AVAILABLE STATIC PRESSURE Pa.
 (●) WRONG STATUS ON ACCOUNT OF MOTOR POWER LIMIT.

NOTE: The unit leaves factory with pulley 2 turns opened for models 22E to 100D and with pulley 6 turns opened for models 112D to 152D.

NOTE: Additional pressure drop with the option high efficiency air filter-EU4 is 50Pa. (Only for models 56E-76E-112D-128D-152D).

1.- GENERAL CHARACTERISTICS

1.4.- UNIT DIMENSIONS

MODELS 22E-24E-28E-32E

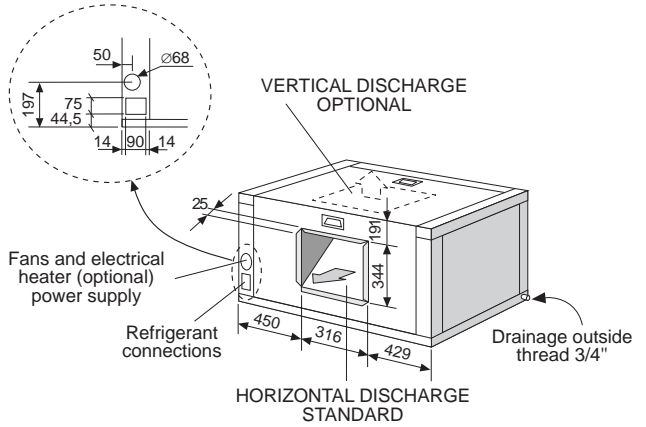
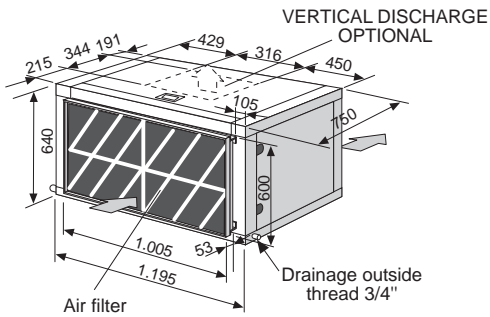

MODEL 38E

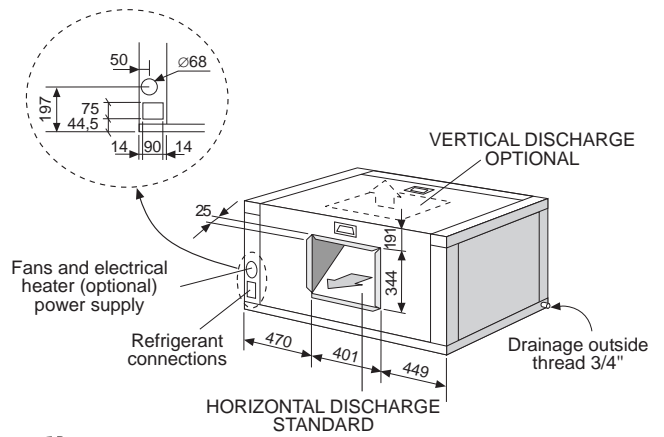
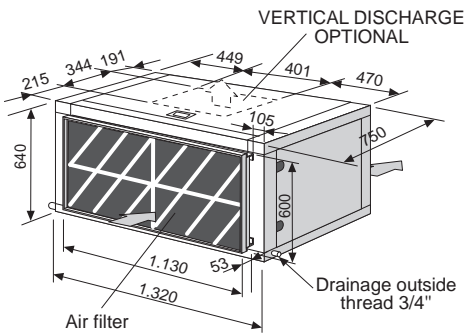

MODELS 43E-50E

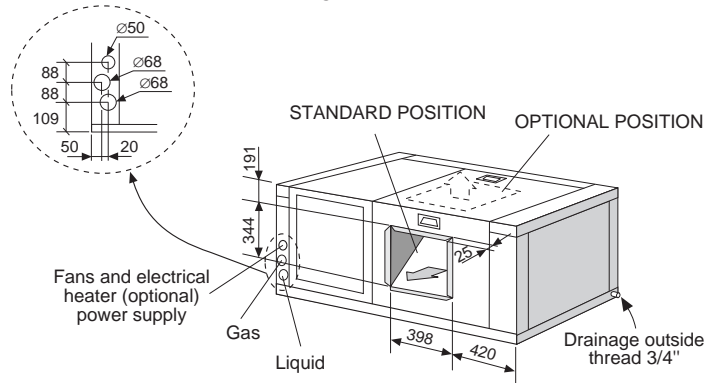
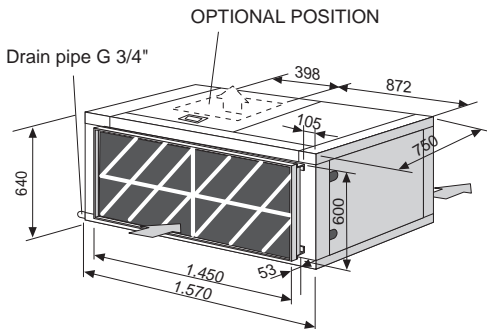

MODELS 56E-76E

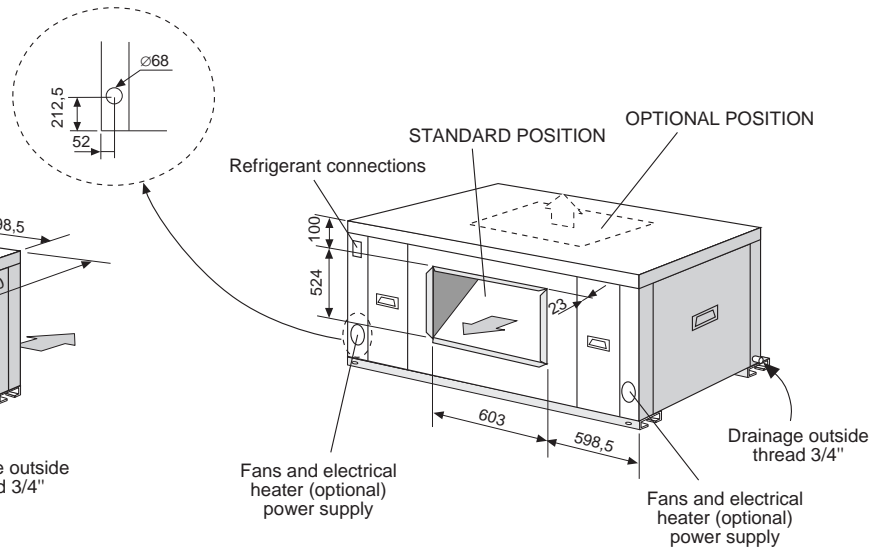
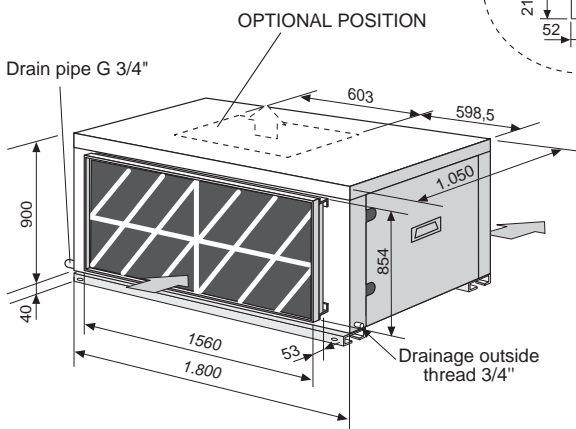

1.- GENERAL CHARACTERISTICS

1.4.- UNIT DIMENSIONS

MODELS 44D-48D-56D-64D

VERTICAL DISCHARGE
OPTIONAL

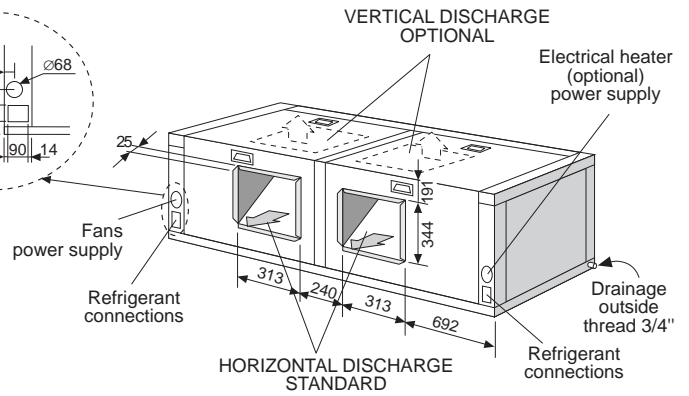
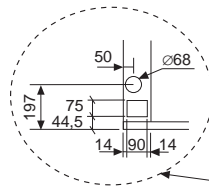
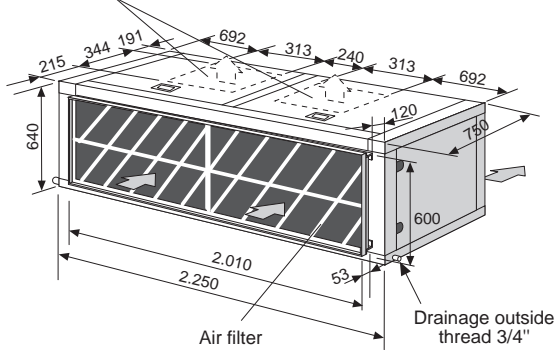

MODEL 76D

VERTICAL DISCHARGE
OPTIONAL

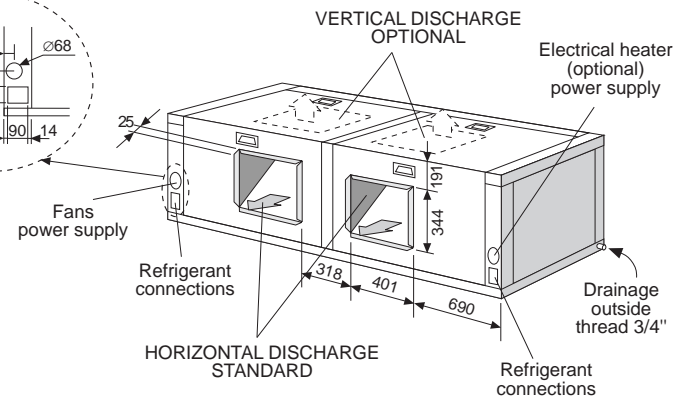
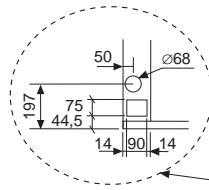
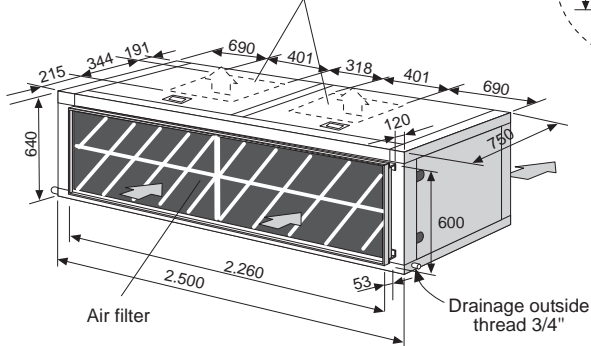

MODELS 86D-100D

Drain pipe G 3/4"

OPTIONAL POSITION

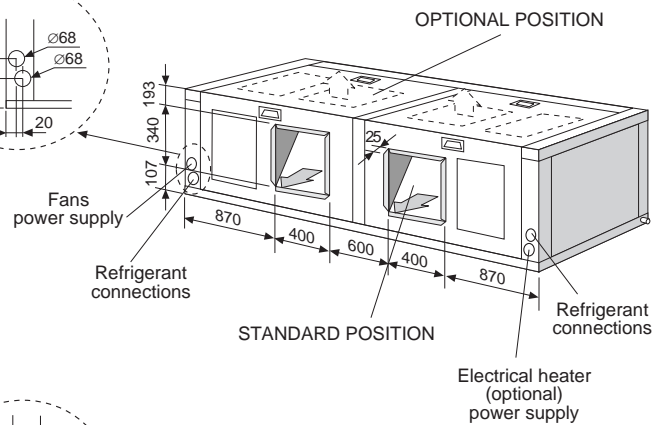
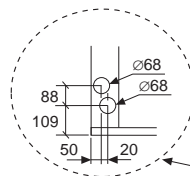
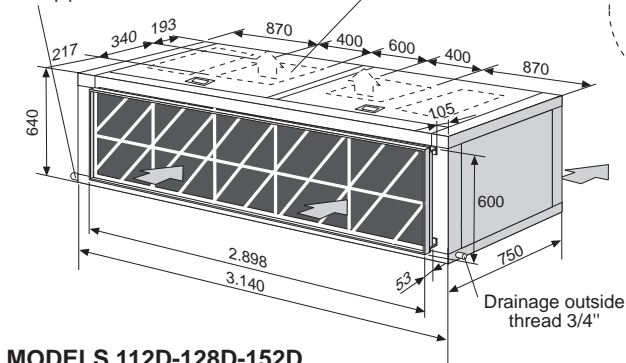

MODELS 112D-128D-152D

Drain pipe G 3/4"

OPTIONAL POSITION

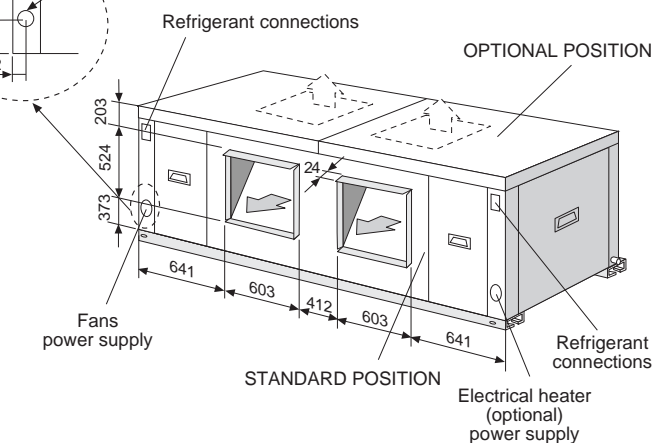
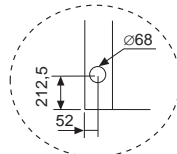
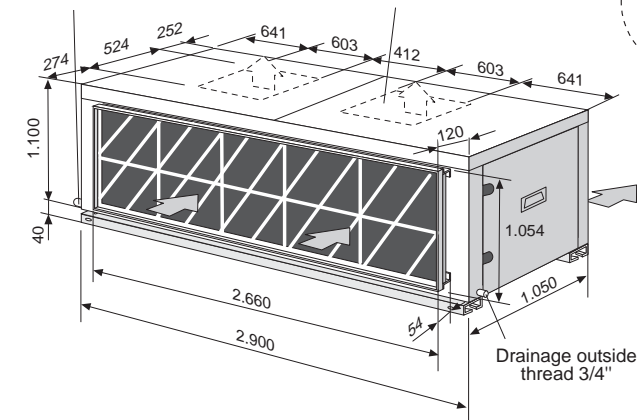

1.- GENERAL CHARACTERISTICS

1.5.- AVAILABLE OPTIONS

ELECTRICAL HEATER

Made of aligned shielded elements, supplied mounted on the unit as drawing shows.

All the range has three security elements: 2 security thermostats, one automatic, other manual reset, and an air flow security pressure switch, which makes the electrical heater stop when air flow is not enough.

The electrical heater must be supplied from the unit's electrical box.

An small case on the electrical heater protects contactors and electrical connections.

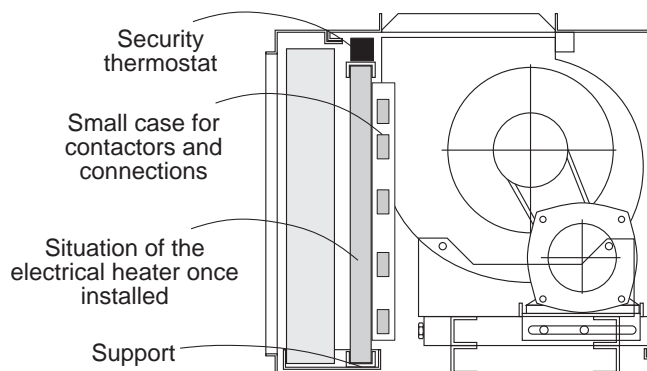

MODELS LEC	22E-24E-28E 32E-38E			43E-50E		56E		76E		44D-48D-56D-64D 76D				86D-100D			112D-128D 152D		
POWER kW	7,5	11	15	11	15	15	20	20	30	11	15	20	30	15	22,5	30	40	60	
MAXIMUM CURRENT (A)	230 / III	18,8	27,6	37,7	27,6	37,7	----	----	----	----	27,6	37,7	50,2	75,3	37,7	56,5	75,3	----	----
	400 / III	10,8	15,9	21,7	15,9	21,7	21,7	28,9	28,9	43,3	15,9	21,7	28,9	43,3	21,7	32,5	43,3	57,7	86,6
WEIGHTS Kg (*)	10			10		24		24		20				30			45		
STAGES	1			1		1		2		1	1	2		1	1	2	2		2

(*) Add to the unit's weight.

MODELS LEH	22E-24E-28E-32E 38E-43E-50E			56E-76E		44D-48D-56D-64D-76D			86D-100D		112D-128D 152D		
POWER kW	7,5	11	15	15	20	11	15	20	15	22,5	30	40	
MAXIMUM CURRENT (A)	230 / III	18,8	27,6	37,7	----	----	27,6	37,7	50,2	37,7	56,5	----	----
	400 / III	10,8	15,9	21,7	21,7	28,9	15,9	21,7	28,9	21,7	32,5	43,3	57,7
WEIGHTS Kg (*)	10			24		20			30		45		
STAGES	1			1		1			1		1		

(*) Add to the unit's weight.

DIRTY FILTER INDICATION

To be installed on the indoor unit.

Based on an air flow security pressure switch, which detects the available static pressure through the air filter.

In case the filters are dirty, the detector is activated showing an alarm, only if the fan is ON.

SMOKE DETECTOR

Located downstream of the filter, the ionic head of the smoke detector can detect any type of smoke. In this case it would initiate shutdown sequence the unit, fully close the return air damper and open the fresh air damper up to 100% and send an alarm signal to the unit.

HIGH EFFICIENCY AIR FILTER EU4 (Only for units 56E-76E-112D-128D-152D)

This kit includes a high efficiency air filter EU4.

AIR QUALITY PROBE CO₂ (Only for C50 version with enthalpic free cooling)

It includes an air quality probe (CO₂).

Air fresh damper is opened when the air quality is below the desired value.

AIR DIFFERENTIAL PRESSURE TRANSDUCER-DPT (Only for C50 version)

It is included with the option Dirty filter indication.

1.- GENERAL CHARACTERISTICS

1.5.- AVAILABLE OPTIONS

HOT WATER COIL

The hot water coil consists of a refrigerating coil made of copper tubing, with aluminum swirl fins with inlet and outlet water connections.

It is supplied mounted inside the unit as picture shows.

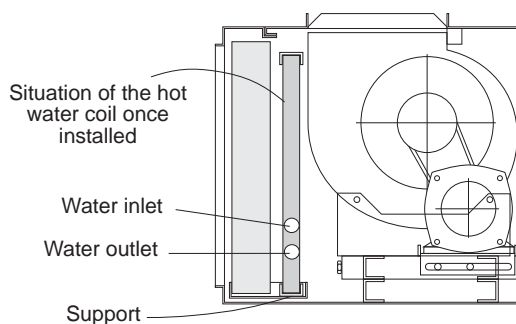

MODELS LEC / LEH (CAPACITY IN W)	DIFFERENCE IN TEMPERATURES BETWEEN HOT WATER INTAKE AND THE AIR WHICH ENTERS THE COIL			WATER FLOW L/H	WATER COIL PRESSURE DROP kPa	AIR PRESSURE DROP Pa (*)	Nr ROWS	WEIGHT Kg	WATER OUTLET DIAMETER Inches
	50°C	60°C	70°C						
24E	29.000	36.000	44.000	2.200	8	40	2	10	3/4"
32E	33.000	40.000	47.000	2.500	10	40	2	10	3/4"
38E	40.000	48.000	56.000	3.000	15	40	2	12	3/4"
56E-76E	61.000	74.000	86.000	6.000	10	30	2	20	1"
48D	58.000	62.000	88.000	4.400	8	40	2	20	3/4"
64D	66.000	80.000	94.000	5.000	10	40	2	20	3/4"
76D	80.000	96.000	112.000	6.000	15	39	2	24	3/4"
112D-128D-152D	124.000	150.000	175.000	11.000	20	30	2	40	1-1/2"

(*)Nominal air flow volume.

PROTECTION AGAINST FREEZING:

• Use glycol water. GLYCOL IS THE ONLY EFFECTIVE PROTECTION AGAINST FREEZING.

• 1.) **For Standard and VFC versions** this kit includes a security thermostat with a probe located inside the hot water coil. When the temperature is below 4°C, the unit will stop in order to protect hot water coil and to prevent unit working with very low evaporating temperatures.

Two wires between indoor and outdoor unit have to be added with this option.

Security thermostat working mode:

- *Electrical boxes with Climatic 10 controller:* The security stop valve is 4°C. When the valve is more than 4°C + thermostat differential, you can reset the unit pressing "resume" button in the Climatic 10 terminal.
- *Electrical boxes with VFC:* The security stop valve is 4°C too. When the valve is more than 4°C + thermostat differential, the unit will reset automatically after 5 min of timer.

2.) **For C50 version**, hot water coil includes a regulation valve which is managed by Climatic 50 controller. Drain the installation. You must ensure that the manual or automatic air vents have been installed on all high points in the system. In order to drain the system check that all the drain cocks have been installed on all low points of the system.



A HEATING COIL FROZEN DUE TO LOW AMBIENT CONDITIONS IS NOT COVERED BY THE WARRANTY.

KIT MORE STATIC PRESSURE OF AIR DISCHARGE

It is a specific fan to obtain more available static pressure up to 400 Pa for indoor unit. See air flow data section for optional fan performances.

Electrical data for these optional fans:

MODELS LEC / LEH	22E	24E	28E	32E	38E	43E	50E	56E	76E	44D	48D	56D	64D	76D	86D	100D	112D	128D	152D
POWER (*) kW	0,2	0,4	0,8	1	1	0,8	0,8	1	1	0,4	0,8	1,5	1,5	1,7	1,5	1,5	2	2	2
MAXIMUM CURRENT (*) (A)	0,5	1,0	2,0	2,5	2,5	2,0	2,0	---	---	1,0	2,0	3,8	3,8	4,3	3,8	3,8	---	---	---
CURRENT (*) (A)	0,3	0,6	1,2	1,4	1,4	1,2	1,2	1,45	1,45	0,6	1,2	2,2	2,2	2,5	2,2	2,2	2,9	2,9	2,9
WEIGHTS Kg (*)	0	0	0	2	0	0	0	5	5	5	5	9	9	9	0	0	20	20	20

(*) Add to the standard unit's data.

1.- GENERAL CHARACTERISTICS

1.5.- AVAILABLE OPTIONS

FREE COOLING

1.- DEFINITION

FREE-COOLING is a saving system in the Cooling cycle, this makes the unit take air from the outside to take advantage of its energy, this system acting as a first cold stage.

It is a saving energy system, that is why many countries regulations recommend and others put under an obligation to install a free cooling system with the unit.

2.- TYPES OF FREE COOLING

According to outside air parameters which have to be measured, the types are:

- Thermostatic free cooling:

Measures and compares the outside air temperature with the temperature of the room that has to be conditioned.

- Enthalpic free cooling:

Measures and compares the outside air enthalpy with the return air enthalpy from the room that has to be conditioned.

The enthalpy measures temperature and humidity of air.

3.- COMPONENTS OF FREE COOLING

The main components are:

-Electronic control and accessories: Their function is to detect the outside and indoor air conditions through the probes, deciding when free cooling should operate.

-The servomotor and system transmission: They manage the opening and closing of dampers.

- Adjustable dampers.

-Mixing section: Where outside and return air are mixed.

Also a return fan is available, which applies an additional static pressure on the suction and return air duct.

For more details about components and drawings see pages 16 to 20.

4.- OPERATION

The control compares the values of temperature/enthalpy between outside air and room air through the probes, if it is a negative difference and the security elements allow (discharge temperature probes) then the control acts over the servomotor, which produces the opening of the outside damper and close the return one, entering cool outside air to the room.

The damper regulation is proportional.

If indoor air demand is not great, could be enough only the free cooling to condition the room, if the air demand is greater it is possible need the free cooling working and the unit working on different cooling mode stages.

5.- THERMOSTAT TERMINAL

Depends on the type of free cooling selected, the thermostat and the electrical box supplied with the unit will be different.

With thermostatic free cooling the thermostat supplied has the same characteristics than the one supplied with the standard unit. With Climatic 10 control includes a programmable terminal.

With enthalpic free cooling the terminal is different than the one supplied with the unit VFC version, its principal characteristics are: OFF, COOL, HEAT, AUTOMATIC.

THERMOSTAT FOR THERMOSTATIC FREE COOLING

Thermostatic free cooling is supplied with sensor incorporated inside the thermostat. Remote duct and ambient sensor are available as an option.

(For all models)



Climatic 10

THERMOSTAT FOR ENTHALPIC FREE COOLING

Enthalpic free cooling is supplied with duct sensor.

Remote ambient sensor and sensor incorporated inside the thermostat are available as an option.

(Only for models 22E to 50E and 44D to 100D)

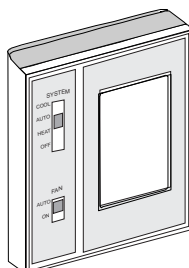

THERMOSTAT FOR THERMOSTATIC AND ENTHALPIC FREE COOLING

Free cooling supplied with ambient sensor. With enthalpic free cooling (C50 units) BE50 expansion module is needed as option too.

(Only for models 56E-76E-112D-128D-152D)



Climatic 50

1.- GENERAL CHARACTERISTICS

1.5.- AVAILABLE OPTIONS

FREE COOLING

6.- SUPPLY AND INSTALLATION

The free cooling option can be delivered as a packaged system or as a split system.

Mixing section will be delivered with the unit for models 22E to 50E and 44D to 100D and as split system for models 56E-76E-112D-128D-152D.

Return fan section will be delivered with the unit + mixing section for models 22E to 50E and 44D-64D and as split system for models 56E-76E and 76D to 152D.

Configuration of free cooling supply :

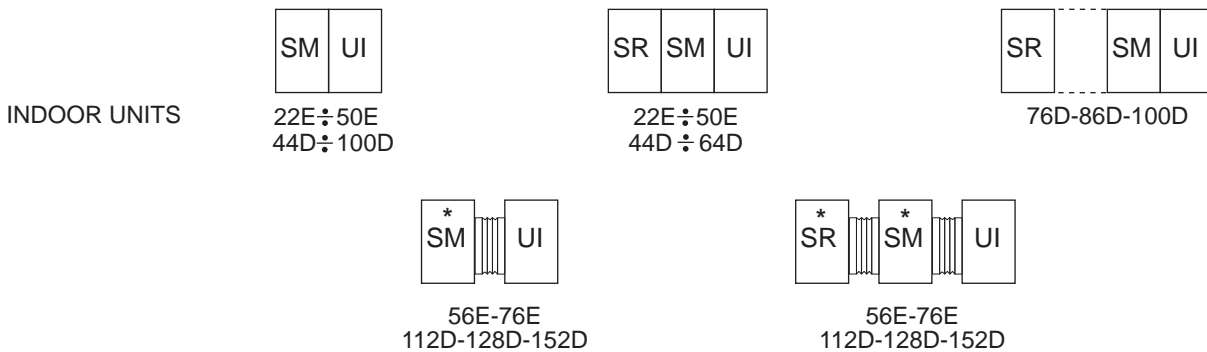

SM: Mixing section

SR: Return fan section

UI: Indoor unit.

- - - Mechanical installation to be carried out by the installer.

Flexible duct to install by the customer.

* Mixing and return fan section can be near or not.

The electrical box for the enthalpic free cooling is supplied apart, and has to be fixed by the installer.

7.-EXHAUST FAN (Only for models 56E-76E-112D-128D-152D)

Exhaust fan electrical consumption:

MODELS	56E	76E	112D	128D	152D
POWER (kW)	2,65	2,65	5,3	5,3	5,3
MAXIMUM CURRENT (A) 400 / III	4,5	4,5	9	9	9
WEIGHTS Kg (*)	37	37	65	65	65

(*) Add to the unit's weight.

With C50 units version and exhaust fan as option, BE50 expansion module is needed too.

8.- FREE COOLING WITH RETURN FAN

If an extra static pressure is required on the return air duct, the free cooling should add a return fan section.

This return fan section includes a discharge damper.

The operation dampers for this free cooling with return fan is as follow:

As much as the air intake damper opens, that much the by-pass damper closes and the discharge air damper opens, for the air return suction (see drawing).

This means that at the same time reach a free cooled of the room, the discharge or return air and the air of the room gets removable.

Return fan electrical consumption:

MODELS	22E	24E	28E	32E	38E	43E	50E	56E	76E	44D	48D	56D	64D	76D	86D	100D	112D	128D	152D
POWER (kW)	1,3	1,4	1,5	1,8	2	2,5	2,8	3	3	2,6	2,8	3	3,6	4	5	5,5	5,5	5,5	5,5
MAXIMUM CURRENT (A) 230 / III	4,3	4,3	6,2	6,2	6,2	10,3	10,3	---	---	8,8	8,8	12,5	12,5	12,5	20,6	20,6	---	---	---
MAXIMUM CURRENT (A) 400 / III	2,5	2,5	3,6	3,6	3,6	6	6	7,2	7,2	5,1	5,1	7,2	7,2	7,2	11,9	11,9	11,9	11,9	11,9

1.- GENERAL CHARACTERISTICS

1.5.- AVAILABLE OPTIONS

FREE COOLING

Return fan performances for each models are:

		22E					24E					28E							
AIR FLOW		R.P.M.	M ³ /H	3500	3900	4300	4700	R.P.M.	M ³ /H	3900	4300	4700	5100	R.P.M.	M ³ /H	4500	4950	5400	5850
PULLEY POSITION	PULLEY CLOSED	1010	175*	145*	115*	70*	1010	145*	115*	70*	35*	1140	175*	130*	85*	30*			
	1 TURN	955	135*	105*	70*	35*	955	105*	70*	35*	0*	1070	130*	80*	30*	0*			
	2 TURNS	900	110*	85*	33*	0*	900	85*	33*	0*	—	995	80*	30*	0*	—			
	3 TURNS	845	75*	50*	5*	—	845	50*	5*	—	—	920	35*	0*	—	—			
		32E					38E					43E							
AIR FLOW		R.P.M.	M ³ /H	4750	5250	5750	6000	R.P.M.	M ³ /H	5800	6400	7000	7300	R.P.M.	M ³ /H	6500	7250	8000	8750
PULLEY POSITION	PULLEY CLOSED	1140	160*	80*	35*	0*	890	210*	183*	145*	125*	1075	320*	275*	215*	165*			
	1 TURN	1070	110*	40*	0*	—	840	170*	140*	104*	85*	1010	265*	215*	155*	125*			
	2 TURNS	995	60*	0*	—	—	790	130*	95*	45*	35*	995	210*	155*	90*	30*			
	3 TURNS	920	10*	—	—	—	740	85*	60*	20*	0*	920	170*	115*	50*	0*			
		50E					56E					76E							
AIR FLOW		R.P.M.	M ³ /H	7250	8000	8750	9000	R.P.M.	M ³ /H	9000	10000	11000	11250	R.P.M.	M ³ /H	10000	11000	12000	12500
PULLEY POSITION	PULLEY CLOSED	1075	310*	255*	195*	●	800	425*	405*	380*	370*	800	405*	380*	335*	●			
	1 TURN	1010	240*	180*	110*	85*	770	400*	380*	335*	325*	770	380*	335*	305*	●			
	2 TURNS	995	160*	115*	45*	20*	735	350*	335*	285*	275*	735	335*	285*	255*	230*			
	3 TURNS	920	80*	45*	—	—	700	305*	285*	240*	230*	700	285*	240*	210*	190*			
		44D					48D					56D							
AIR FLOW		R.P.M.	M ³ /H	7000	7800	8600	9400	R.P.M.	M ³ /H	7800	8600	9400	10200	R.P.M.	M ³ /H	9000	9900	10800	11700
PULLEY POSITION	PULLEY CLOSED	1010	330*	320*	300*	280*	1010	320*	300*	280*	●	1010	280*	240*	220*	180*			
	1 TURN	955	290*	275*	250*	230*	955	275*	250*	230*	185*	955	250*	205*	160*	110*			
	2 TURNS	900	250*	235*	210*	180*	900	235*	210*	180*	130*	900	195*	160*	110*	70*			
	3 TURNS	845	200*	195*	150*	130*	845	195*	150*	130*	85*	845	150*	115*	70*	30*			
		64D					76D					86D							
AIR FLOW		R.P.M.	M ³ /H	9500	10500	11500	12000	R.P.M.	M ³ /H	11600	12800	14000	14600	R.P.M.	M ³ /H	13000	14500	16000	17500
PULLEY POSITION	PULLEY CLOSED	1010	275*	245*	185*	155*	890	200*	175*	140*	120*	1055	330*	290*	240*	170*			
	1 TURN	955	220*	175*	130*	105*	840	160*	135*	100*	90*	1010	280*	245*	190*	120*			
	2 TURNS	900	175*	130*	75*	55*	790	120*	85*	50*	35*	965	245*	210*	155*	90*			
	3 TURNS	845	125*	85*	30*	20*	740	75*	50*	10*	0*	920	210*	170*	100*	45*			
		100D					128D/152D												
AIR FLOW		R.P.M.	M ³ /H	14500	16000	17500	18000	R.P.M.	M ³ /H	20000	22000	24000	24500						
PULLEY POSITION	PULLEY CLOSED	1055	290*	240*	170*	140*	800	395*	345*	315*	●								
	1 TURN	1010	245*	190*	120*	80*	760	365*	320*	285*	●								
	2 TURNS	965	210*	155*	90*	50*	715	320*	270*	235*	215*								
	3 TURNS	920	170*	100*	45*	0*	680	270*	225*	195*	175*								

(*) AVAILABLE STATIC PRESSURE Pa.

(●) WRONG STATUS ON ACCOUNT OF MOTOR POWER LIMIT.

NOTE: The unit leaves factory with pulley 2 turns opened for models 22E to 100D and with pulley 6 turns opened for models 112D to 152D.

NOTE: Additional pressure drop with the option high efficiency air filter-EU4 is 50Pa. (Only for models 56E-76E-112D-128D-152D).

Air flows with exhaust fan for option "free cooling without return fan"

56E-76E					112D-128D/152D						
AIR FLOW		M ³ /H	6600	7150	7700	8250	M ³ /H	13200	14300	15400	16500
AVAILABLE STATIC PRESSURE Pa.			230	200	150	50		230	200	150	50

1.- GENERAL CHARACTERISTICS

1.5.- AVAILABLE OPTIONS

FREE COOLING

9.- SELECTION OF THE UNIT AND FREE COOLING SYSTEM

There are different types of free cooling system, different possibilities of dampers installations, and it could be supplied mounted or loose. In order to provide the customer the needed one, fill in the following table and sent it to the order department:

INSTALLER COMPANY NAME _____ CONTACT PERSON NAME: _____

TEL.: _____ Fax _____ e-mail _____

ATTENTION TO : Lennox Refac S.A. CONTACT PERSON NAME: _____

TEL.: _____ Fax _____ e-mail _____

ORDER NUMBER: _____

A- Select the unit needed, packaged, split or multi-split:

(If the unit needed is packaged, the free cooling will be supplied loose. If the unit selected is split or multi-split, please check supply and installation in page 13).

Packaged Split Multi-split

B- Select the air flow drive of the indoor unit required: Horizontal or vertical

Packaged units: As standard vertical air flow drive

Split and multi-split systems: As standard horizontal air flow drive

Vertical Horizontal

C.-Select the type of free cooling thermostatic or enthalpic and the sensor for free cooling management.

Thermostatic free cooling supplied with sensor incorporated inside the thermostat,

Enthalpic free cooling supplied with duct sensor

(If the humidity conditions where the unit is going to be install have relevance, is convenient to install an enthalpic free cooling).

Thermostatic Remote ambient sensor
 Remote duct sensor Enthalpic Remote ambient sensor
 Sensor incorporated at the thermostat

D.- Select if you need return fan with the free cooling.

With return fan Without return fan

E.-Select the dampers configuration for the free cooling, as following. (In order to be adapted to the ducts of the installation).

INDOOR UNITS 22E to 50E and 44D to 100D

E.1- Free cooling dampers position WITHOUT return fan:

The drawings are an upper view of the indoor unit and free cooling.

POSITION 1

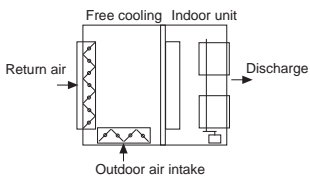

POSITION 2

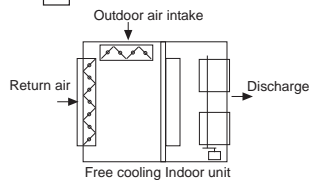

INDOOR UNITS 56E-76E-112D-128D-152D

E.1- Free cooling dampers position WITHOUT return fan:

The drawings are an upper view of the indoor unit and free cooling.

POSITION 1

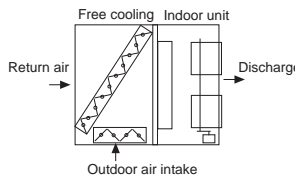

POSITION 2

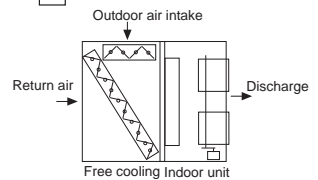

E.2- Free cooling dampers position WITH return fan:

The drawings are an upper view of the indoor unit and free cooling.

POSITION 1

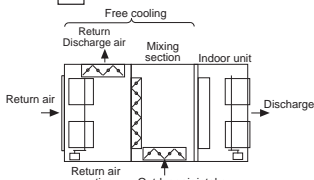

POSITION 2

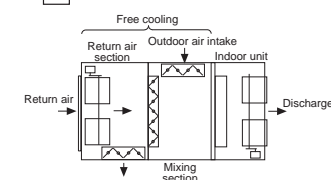

E.2- Free cooling dampers position WITHOUT return fan and with exhaust fan optional:

The drawings are an upper view of the indoor unit and free cooling.

POSITION 1

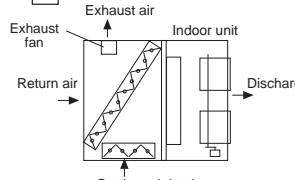

POSITION 2

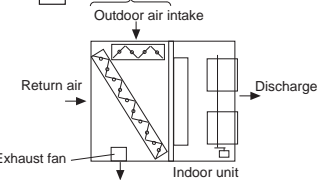

POSITION 3

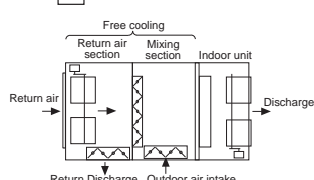

POSITION 4

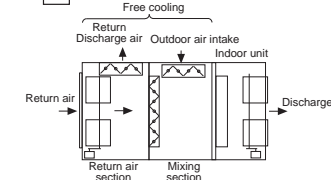

E.3.-Free cooling dampers position WITH return fan:

The drawings are an upper view of the indoor unit and free cooling.

POSITION 1

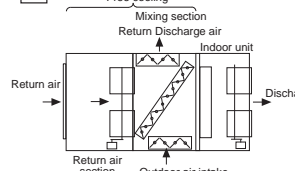

POSITION 2

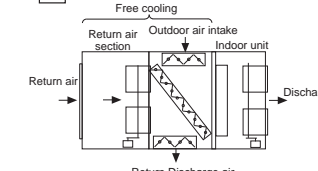

NOTE: Drawings only show dampers and fans situation, but they are not according to the delivery of the different sections (unit, mixing and return fan).

1.- GENERAL CHARACTERISTICS

1.5.- AVAILABLE OPTIONS

FREE COOLING

OUTLINE FOR THERMOSTATIC FREE COOLING WITHOUT RETURN FAN LECK/LEHK 22E to 50E and 44D to 76D

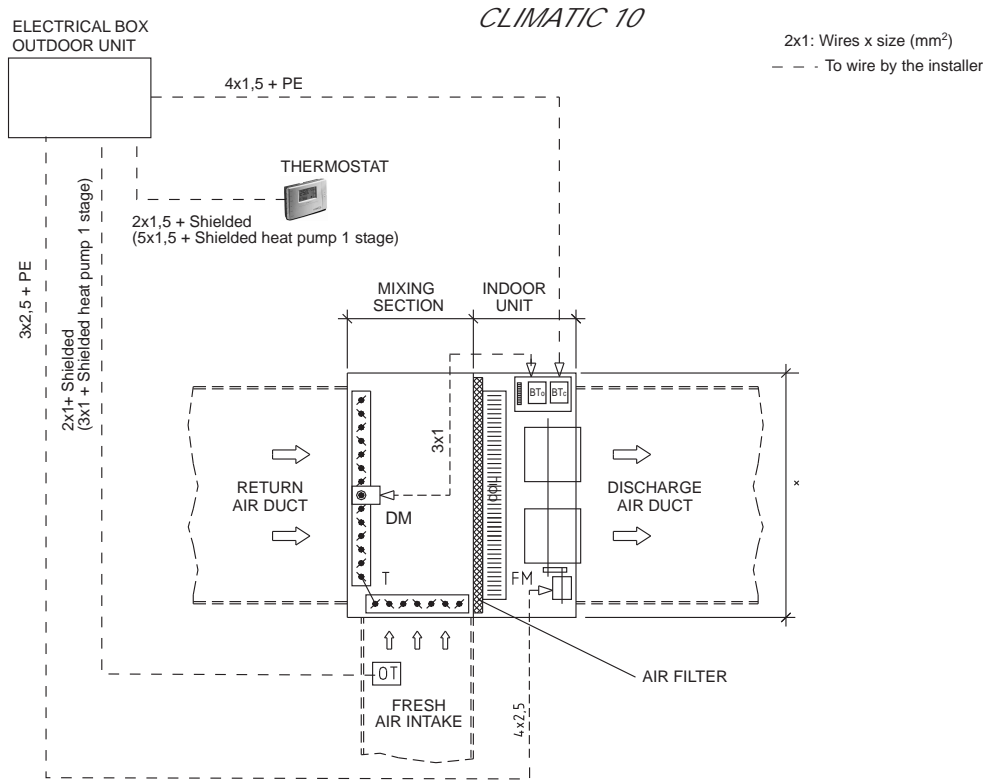

OUTLINE FOR THERMOSTATIC FREE COOLING WITH RETURN FAN LECK/LEHK 22E to 50E and 44D to 76D

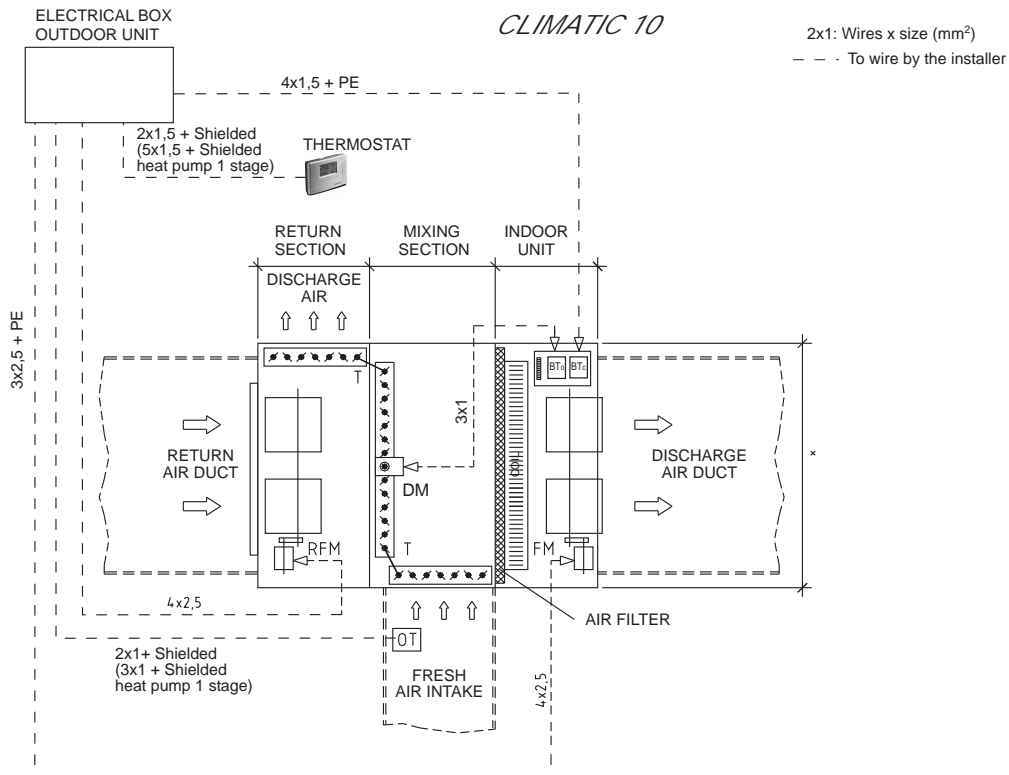

BT_o/BT_c - Free cooling Thermostat
 DM - Damper Actuator

RFM - Return fan motor
 FM - Indoor fan motor

OT - Outdoor temperature sensor
 T - Transmission

1.- GENERAL CHARACTERISTICS

1.5.- AVAILABLE OPTIONS

FREE COOLING

OUTLINE FOR THERMOSTATIC FREE COOLING WITHOUT RETURN FAN LECK/LEHK 86D-100D

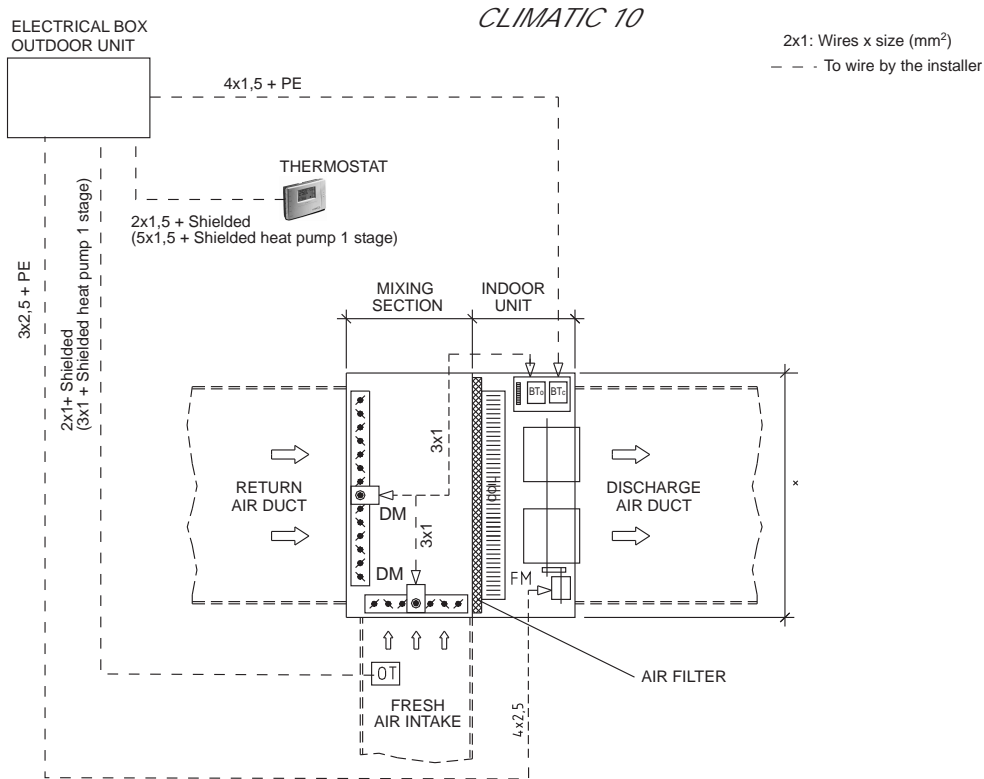

OUTLINE FOR THERMOSTATIC FREE COOLING WITH RETURN FAN LECK/LEHK 86D-100D

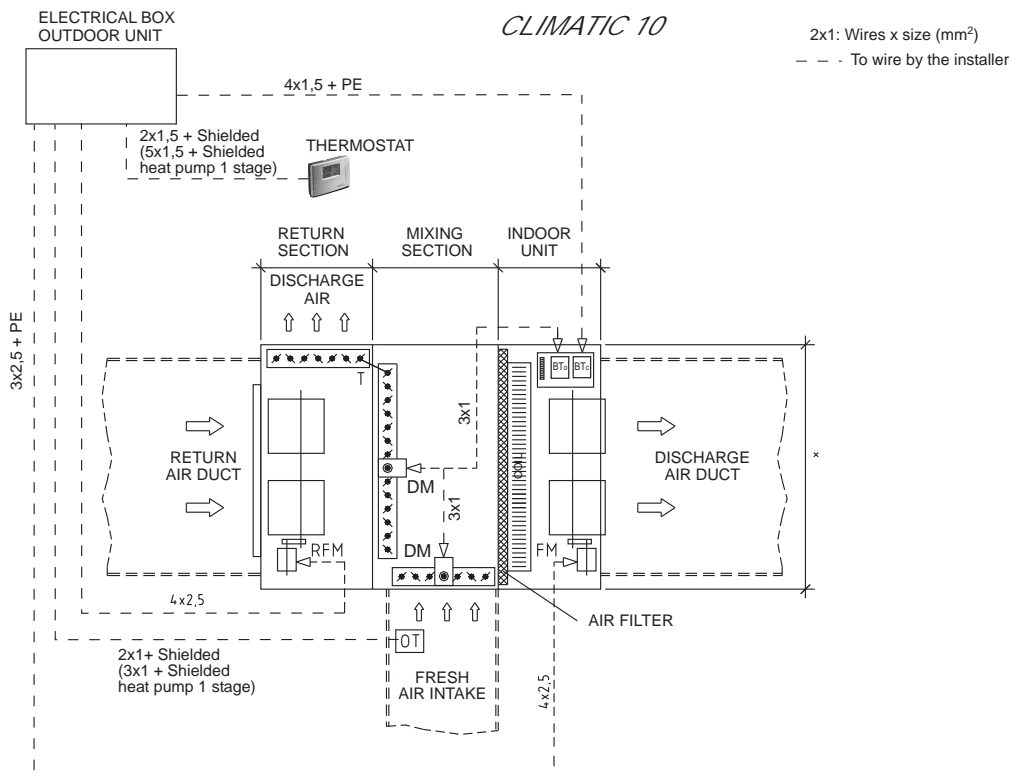

BT_o/BT_c - Free cooling Thermostat
DM - Damper Actuator

RFM - Return fan motor
FM - Indoor fan motor

OT - Outdoor temperature sensor
T - Transmission

1.- GENERAL CHARACTERISTICS

1.5.- AVAILABLE OPTIONS

FREE COOLING

OUTLINE FOR THERMOSTATIC FREE COOLING WITHOUT RETURN FAN

LECK/LEHK 56E-76E-112D-128D-152D

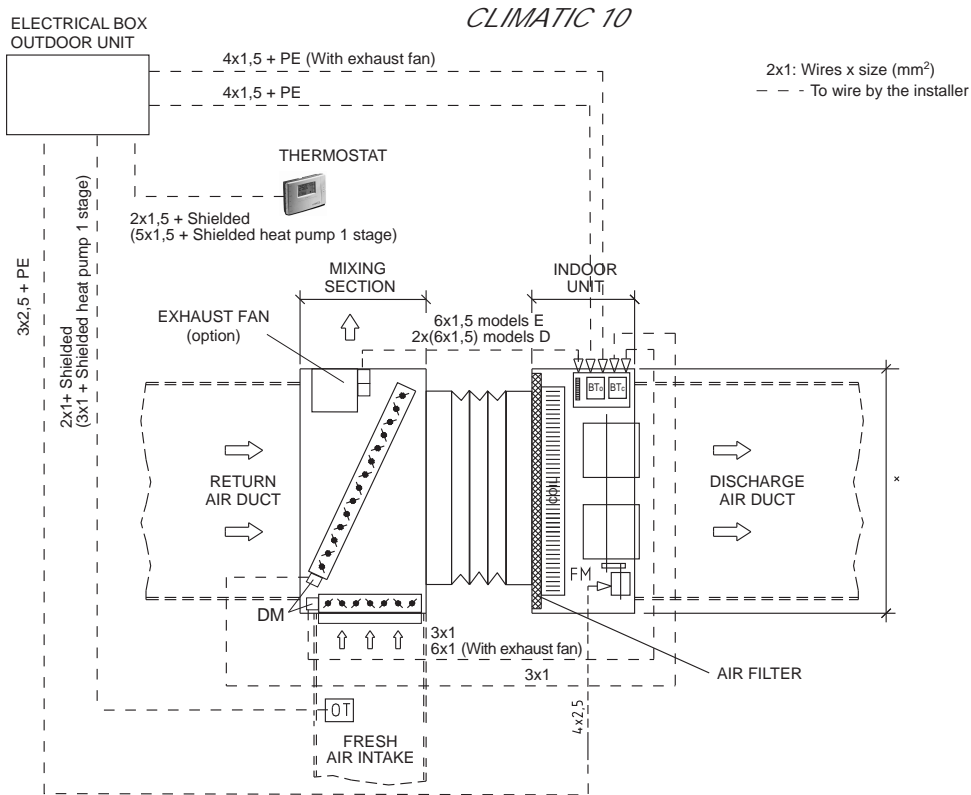

OUTLINE FOR THERMOSTATIC FREE COOLING WITH RETURN FAN

LECK/LEHK 56E-76E-112D-128D-152D

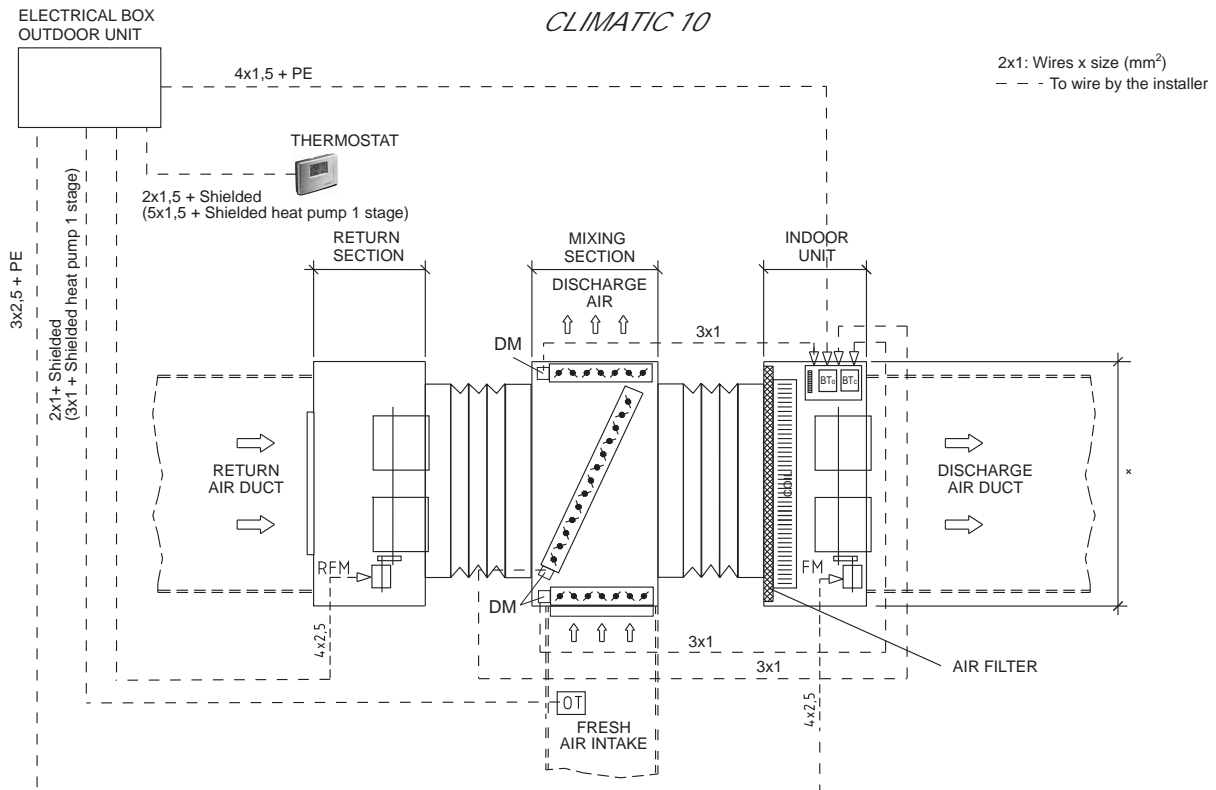

BT_o/BT_c - Free cooling Thermostat
DM - Damper Actuator

RFM - Return fan motor
FM - Indoor fan motor

OT - Outdoor temperature sensor

1.- GENERAL CHARACTERISTICS

1.5.- AVAILABLE OPTIONS

FREE COOLING

OUTLINE FOR THERMOSTATIC AND ENTHALPIC FREE COOLING LECK/LEHK 56E-76E-112D-128D-152D

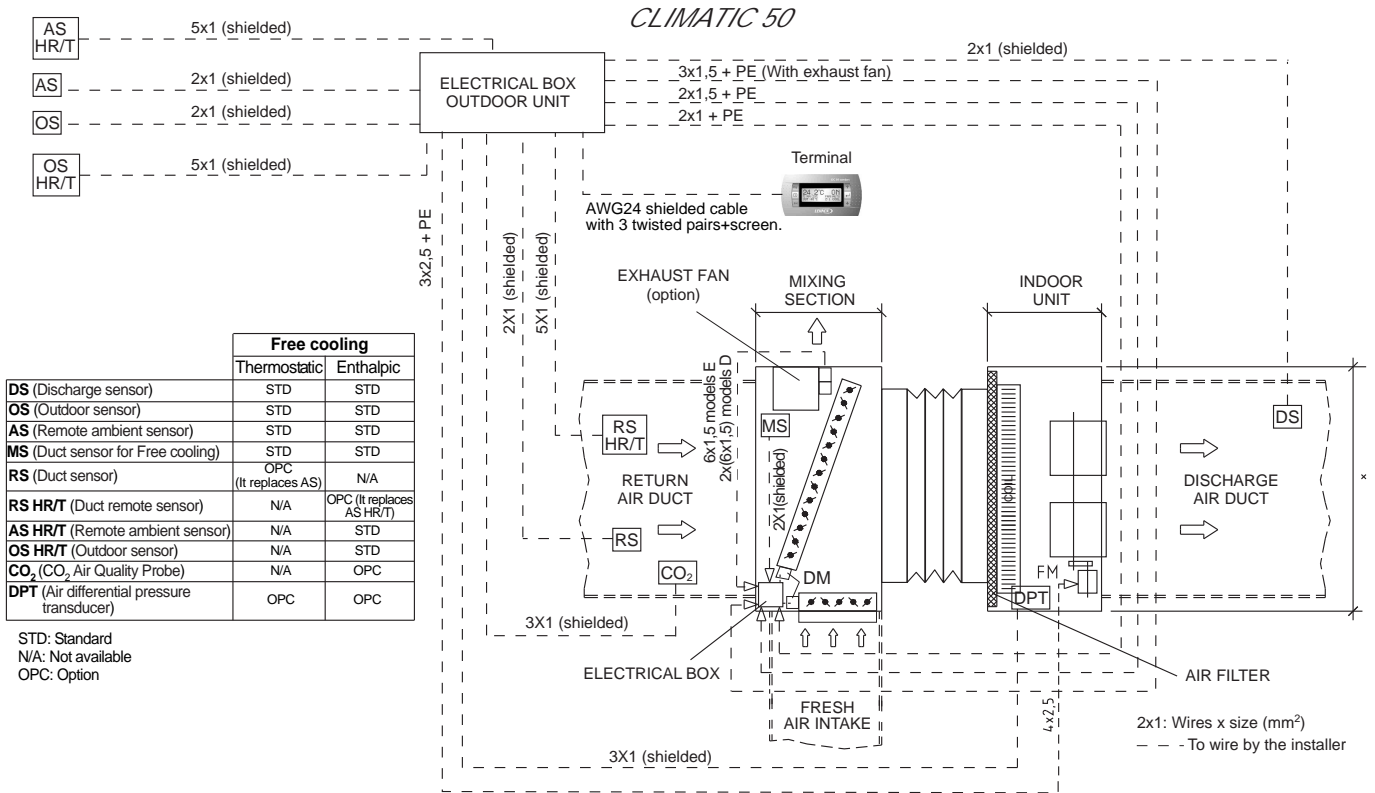

OUTLINE FOR THERMOSTATIC AND ENTHALPIC FREE COOLING WITH RETURN FAN LECK/LEHK 56E-76E-112D-128D-152D

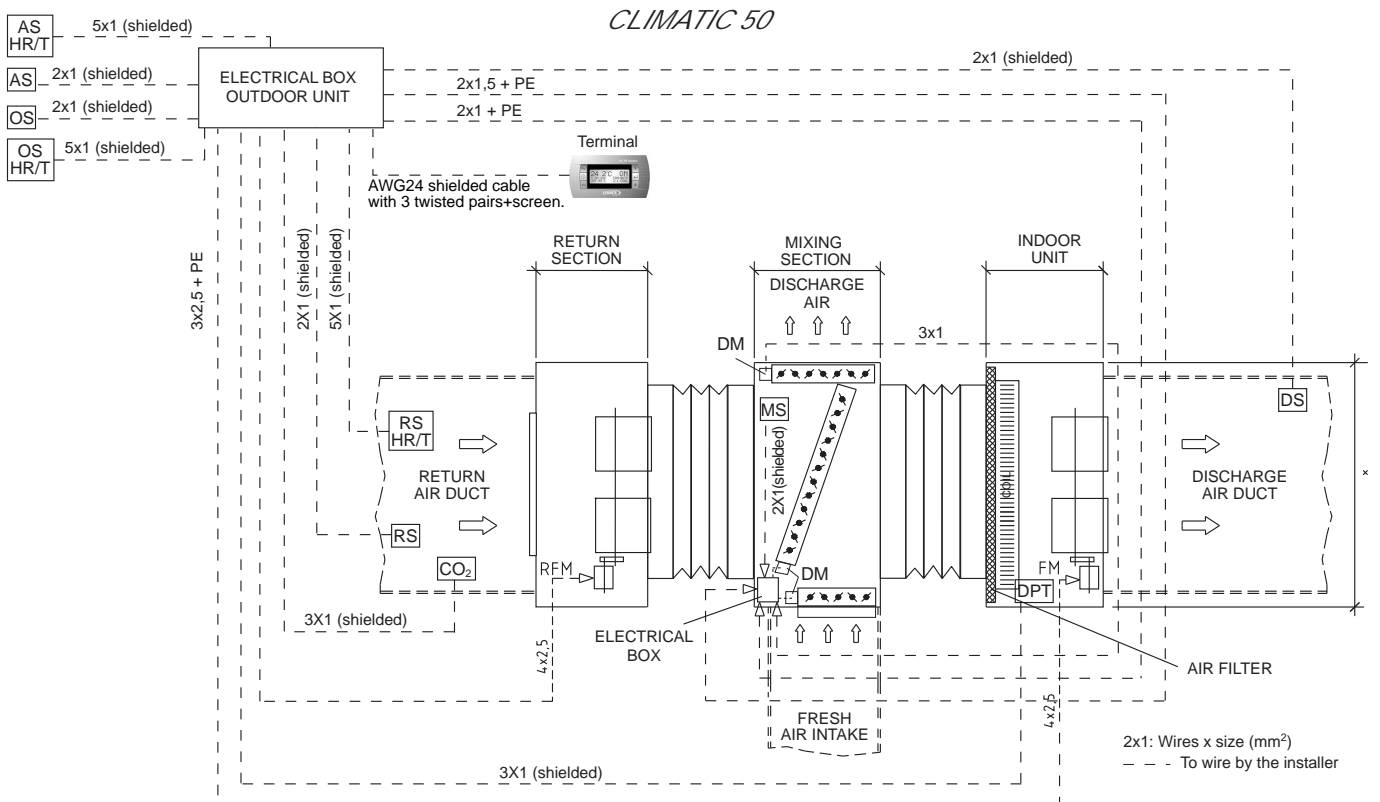

DM - Damper Actuator

RFM - Return fan motor

FM - Indoor fan motor

1.- GENERAL CHARACTERISTICS

1.5.- AVAILABLE OPTIONS

FREECOOLING

OUTLINE FOR ENTHALPIC FREECOOLING WITHOUT RETURN FAN

LECK/LEHK 22E to 50E and 44D to 100D

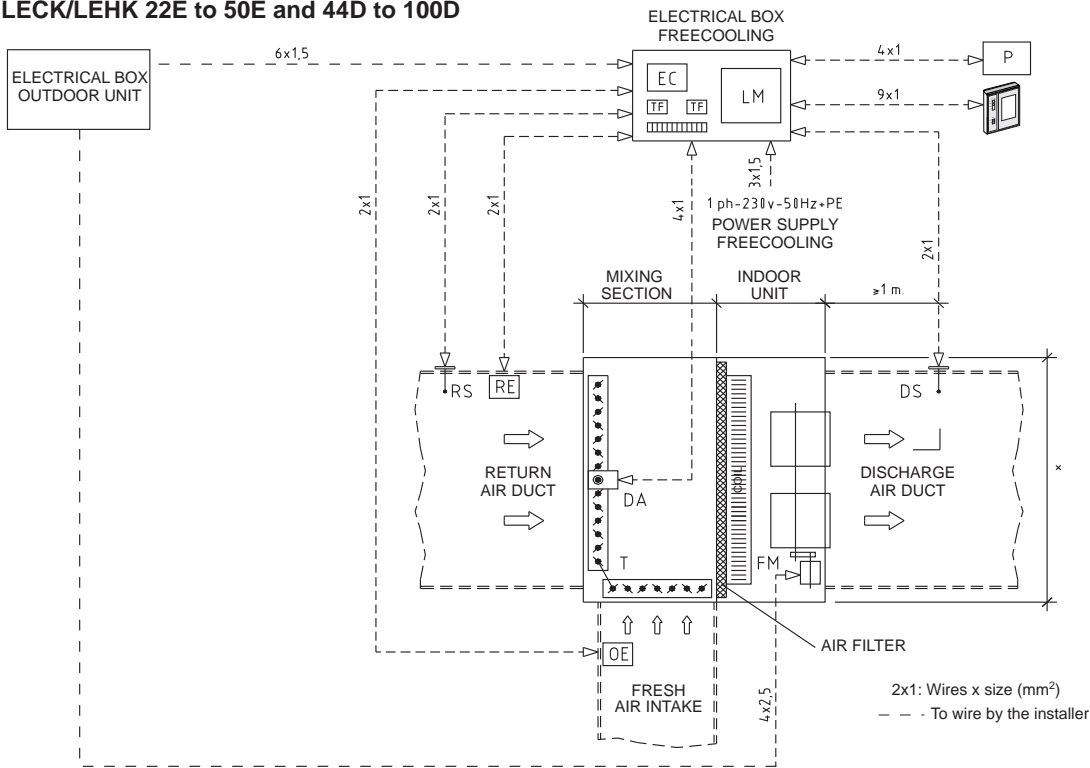

OUTLINE FOR ENTHALPIC FREECOOLING WITH RETURN FAN

LECK/LEHK 22E to 50E and 44D to 100D

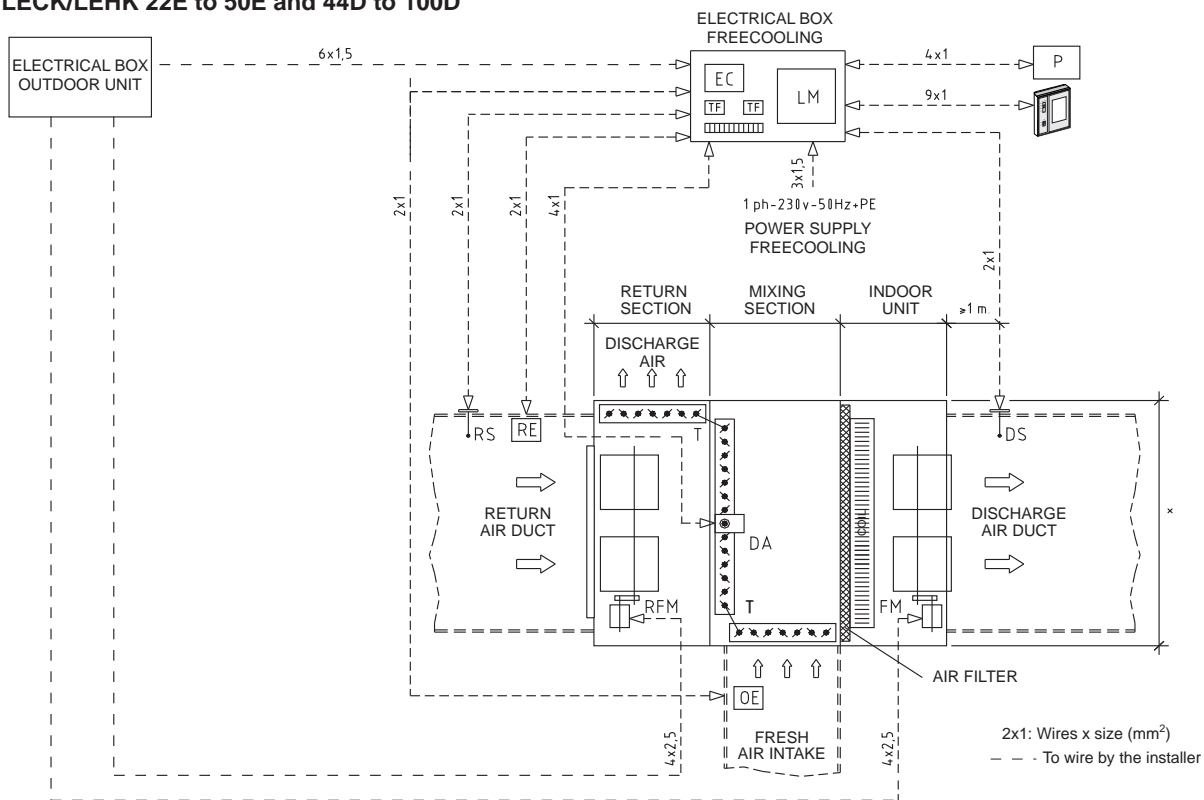

P - Potentiometer
 EC - Enthalpy measure
 LM - Logic module

TF - Transformer
 RC - Remote Controller
 RE - Return Enthalpy sensor

RS - Return Temperature sensor
 DS - Discharge Temperature sensor
 DA - Damper actuator

RFM - Return fan motor
 FM - Indoor fan motor
 OE - Outdoor enthalpy sensor
 T - Transmission

1.- GENERAL CHARACTERISTICS

1.5.- AVAILABLE OPTIONS

FREE COOLING

DIMENSIONS FREE COOLING WITHOUT RETURN FAN

MODELS 22E-24E-28E-32E-38E-43E-50E

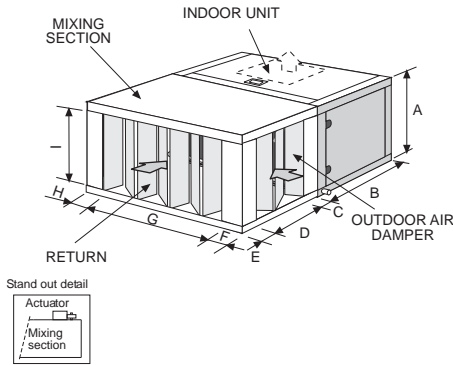

MODELS 56E-76E

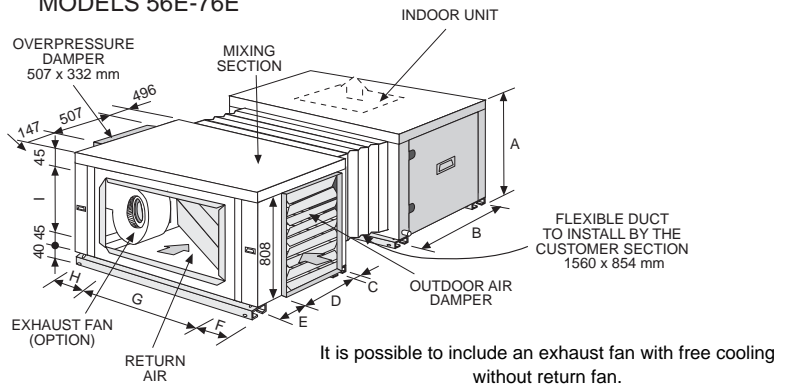

MODELS 44D-48D-56D-64D-76D

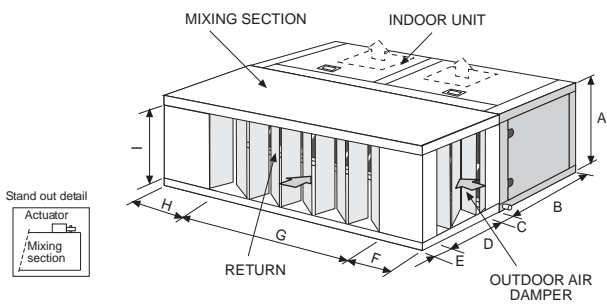

MODELS 86D-100D

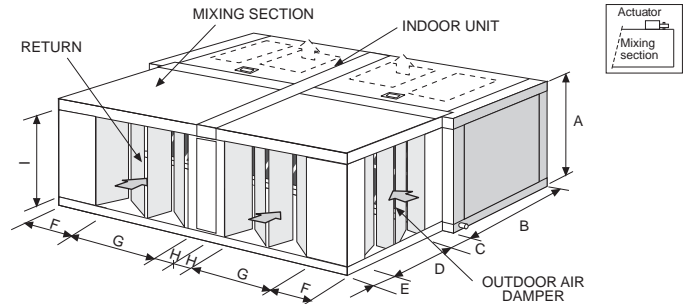

MODELS 112D-128D-152D

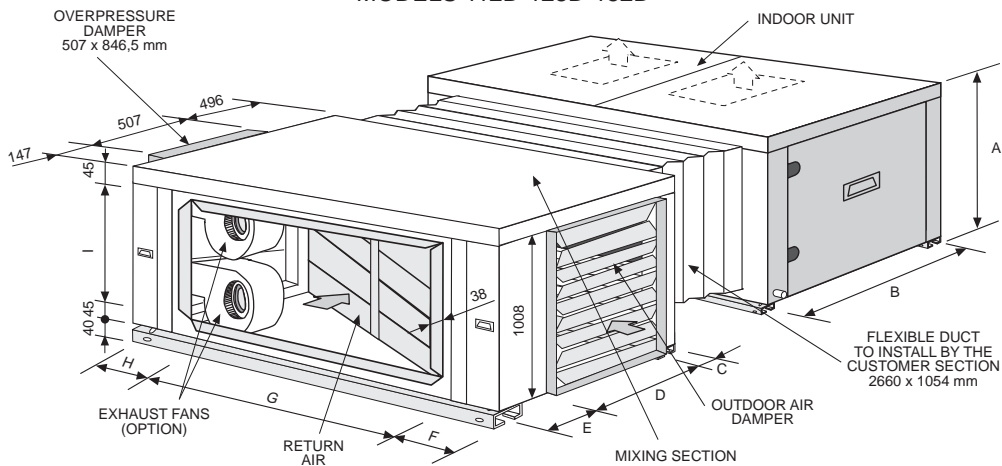

The damper position can be different than the picture shows. See drawings.

MODELS	22E-24E 28E-32E	38E	43E-50E	56E-76E	44D-48D 56D-64D	76D	86D-100D	112D-128D-152D	
A	640	640	640	940	640	640	640	1100	
B	750	750	750	1050	750	750	750	1050	
C	98	73,5	92,5	114	100,5	100,5	50	114	
D	750	750	1015	803	749	749	1000	803	
E	52	76,5	92,5	233	50,5	50,5	150	233	
F	222	222	241	312,5	250	312,5	233	312,5	
G	750	876	1140	1175	1750	1875	1125	2275	
H	222	222	241	312,5	250	312,5	93	312,5	
I	499	500	530	810	499	499	550	1010	
WEIGHTS Kg	Indoor unit	22-24=105 28-32=110	145	43=280 50=305	56=275 76=295	44-48=220 56-64=240	265	86=270 100=295	112=510/ 128=520 152=530
	Mixing section	100	100	130	130	130	135	250	190

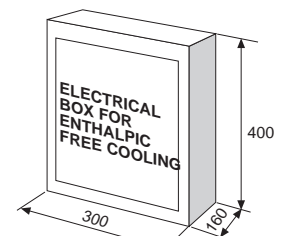

Electrical box for free cooling is supplied loose inside the mixing section. Fix by the installer (Only for enthalpic free cooling models 22E to 50E and 44D to 100D).

1.- GENERAL CHARACTERISTICS

1.5.- AVAILABLE OPTIONS

FREE COOLING

DIMENSIONS FREE COOLING WITH RETURN FAN

MODELS 22E-24E-28E-32E-38E-43E-50E

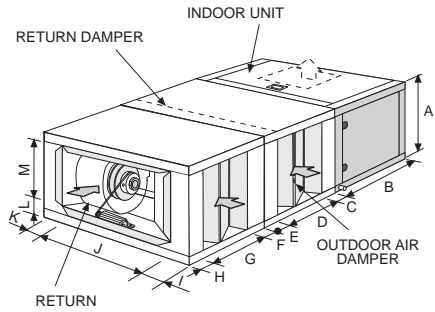

MODELS 56E-76E

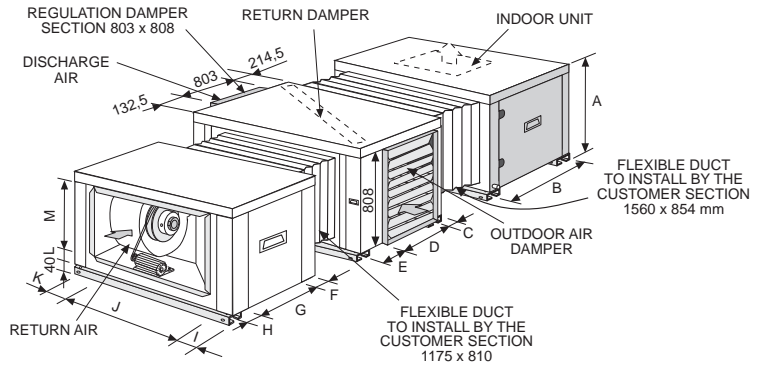

MODELS 44D-48D-56D-64D-76D

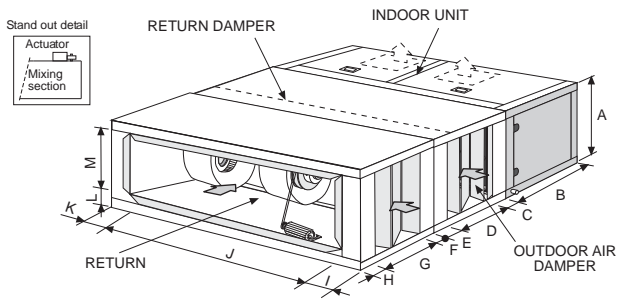

MODELS 86D-100D

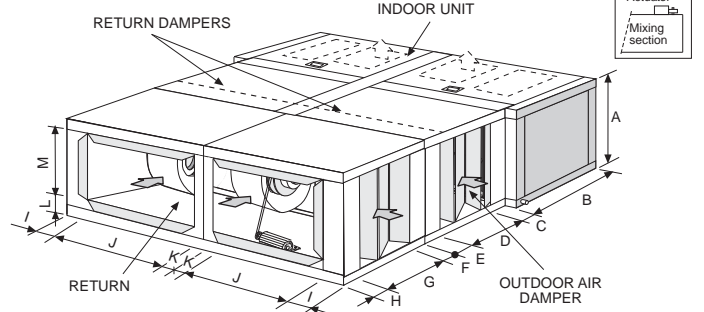

MODELS 112D-128D-152D

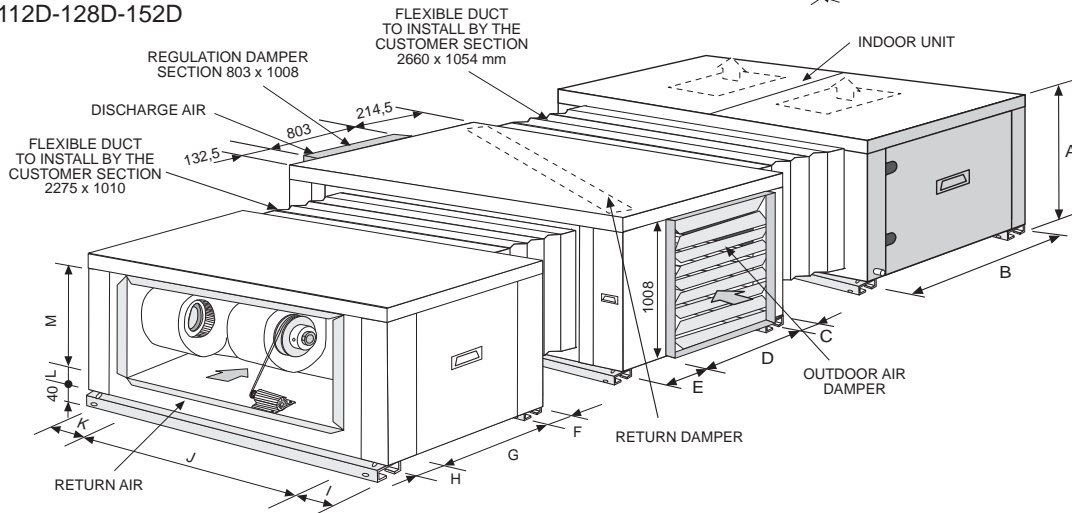

The damper position can be different than the picture shows. See drawings.

MODELS	22E-24E 28E-32E	38E	43E-50E	56E-76E	44D-48D 56D-64D	76D	86D-100D	112D-128D-152D
A	640	640	640	940	640	640	640	1100
B	750	750	750	1050	750	750	750	1050
C	98	73,5	92,5	114	100,5	100,5	50	114
D	750	750	1015	803	749	749	1000	803
E	52	76,5	92,5	233	50,5	50,5	150	233
F	48	48	92,5	112	48	48	45	112
G	750	750	1015	476	750	750	1010	476
H	102	102	92,5	112	102	102	145	112
I	186	186	231	148	186	311	191,5	148
J	822	948	1160	1175	1878	1878	1204,5	2275
K	186	186	231	148	186	311	15	148
L	96,5	96,5	96,5	45	96,5	96,5	88	45
M	500	500	500	810	500	500	500	1010
Indoor unit	22-24=105 28-32=110	145	43=280 50=305	56=275 76=295	44-48=220 56-64=240	265	86=270 100=295	112=510/128=520 152=530
WEIGHTS Kg	Mixing section	100	100	130	130	135	250	190
	Return section	22-24=120 28-32=125	125	210	140	195	200	320
								230

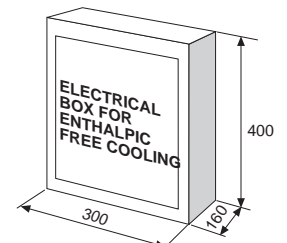

Electrical box for free cooling is supplied loose inside the mixing section. Fix by the installer (Only for enthalpic free cooling models 22E to 50E and 44D to 100D).

2.- INSTALLATION

2.1.- INSTALLATION GUIDELINES



All INSTALLATION, SERVICE and MAINTENANCE operations must be carried out by QUALIFIED PERSONNEL.

The unit must be transported in a HORIZONTAL POSITION on its metal bedplate profiles and TRANSPORTATION BLOCKS. Any other position may cause serious damage to the machine. When the unit is received, it should be checked to assure that there are no bumps or other damage, following the instructions on the packaging. If there is damage, the unit may be rejected by notifying the LENNOX Distribution Department and reporting why the machine is unacceptable on the transport agent's delivery notice. Any later complaint or claim made to the LENNOX Distribution Department, for this type of anomaly, cannot be considered under the Guarantee. Sufficient space must be allowed to facilitate placement of the unit.



When positioning the unit, be sure that the Rating Plate will always be visible since this data will be necessary to assure proper maintenance.

The units are designed to be installed with ducts, calculated by qualified technical staff. The joints to be used between ducts and the openings to the unit should be Elastic Joints. Avoid the use of BYPASS joints between the extraction air and input air in both the outdoor and indoor sections. The structure where the unit is placed must be able to support the weight of the unit during operation. For 112D to 152D models, when the unit is installed outside, the central joint and the vertical discharge panels have to be sealed in order to prevent water from coming inside the unit.

2.2.- OPTIONAL OPERATIONS PRIOR TO UNIT INSTALLATION: CHANGE IN THE POSITION OF DISCHARGE FOR

UNIT MODELS 22E-24E-28E-32E-38E-43E-50E-56E-76E

STANDARD AIR DISCHARGE

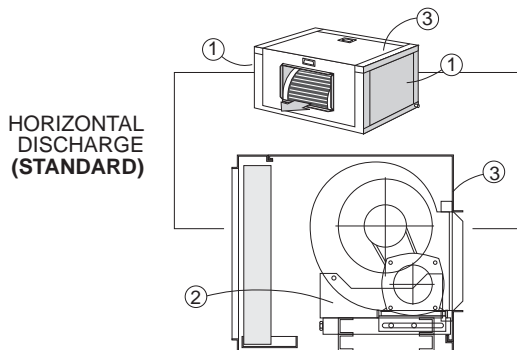

OPTIONAL AIR DISCHARGE

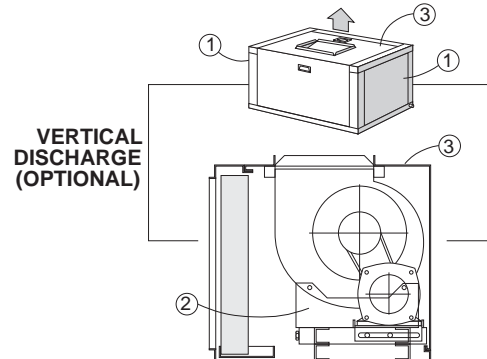

UNIT MODELS 44D-48D-56D-64D-76D-86D-100D-112D-128D-152D

STANDARD AIR DISCHARGE

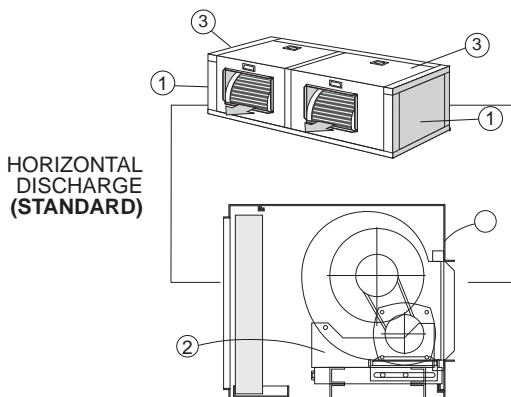

OPTIONAL AIR DISCHARGE

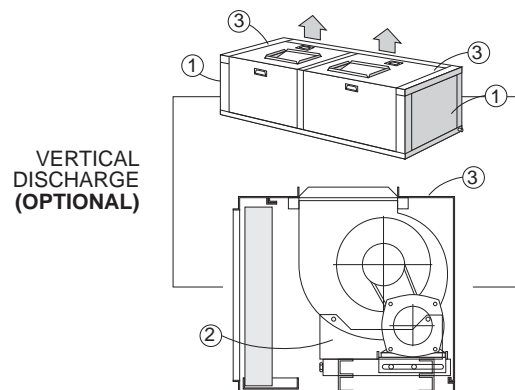

1. Check that unit is electrically disconnected.
2. Unscrew and remove side covers (1) and (3).
3. Loosen the transmission belts and disassemble them.
4. Remove the pulley from the fan axle.
- ATTENTION!! Models 86D-100D: unscrew the bottom bedplate.
5. Remove the fan and its supports (2).
6. Turn the fan until horizontal discharge position is reached.
7. Replace the fan on the supports (2) which should not be moved.
- ATTENTION!! Models 86D-100D: screw the bottom bedplate.
8. Place the pulley on the fan axle on the side which coincides with the motor, assemble the belts and align them.
9. Tense the belts correctly.
10. Replace the upper and lateral covers and screw them down (1) and (3).

NOTE: This option for indoor units 56E-76E-112D/D2-128D/D2-152D needs another option kit which includes some metal parts in order to assemble the unit with vertical discharge.

2.- INSTALLATION

2.3.- OPTIONAL OPERATIONS PRIOR TO UNIT INSTALLATION:

THE VENTILATION FOR LECK- LEHA- LEHK UNITS IS FORMED BY:

- 1.- Centrifugal fan (single or double).
- 2.- Activating motor.
- 3.- Fixed pulley at the fan.
- 4.- Variable pulley at the motor fan.
- 5.- transmission pulley or pulleys.
- 6.- Base of the motor with displacement system for tensioning of belts.
- 7.- Tensing screw.

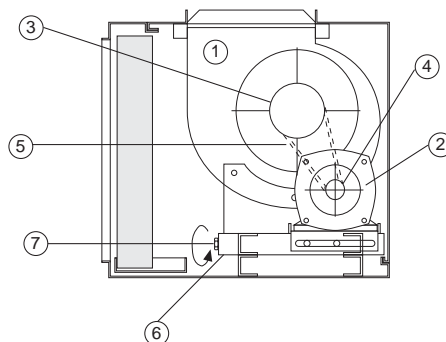

FLOW REGULATION IN THE FANS

The fan in the units have a variable pulley incorporated into the activating motor, by which it is possible to vary, when the fan is off its diameter to modify the air flow of the unit, as required.

1. Fixed part.
2. Mobil part.
3. Fixing screw.

CLOSE PULLEY:

To increase the fan flow, turn the mobil part in direction "B" (Clock wise).

OPEN PULLEY:

To reduce the flow, turn in direction "A" (Unlock wise).

VARIABLE PULLEYS

SIMPLE PULLEY

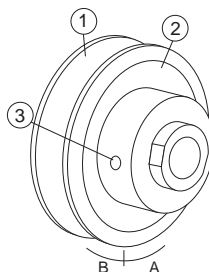

DOUBLE PULLEY

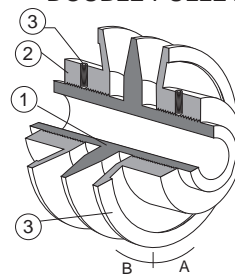

TENSION OF BELTS

The belts can be easily tensioned through the tensing screw incorporated into the bases of the motor of the transmitting units which also enables a good servicing to be carried out.

When the tensing screw is moved, the motor fan is moved to the sides in order to tension the pulley.

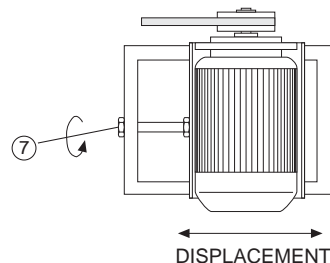

2.4.- INSTALLATION CLEARANCES

Clearance around the unit for service and maintenance.

SERVICE SPACE

Space should be left free for access or servicing, to ease the installation of cables, drainage connections, electric installation and cleaning filters, as well as easy access to the unit.

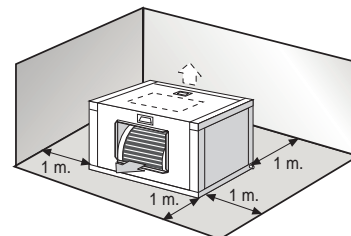

2.5.- DRAINS

All units have a 3/4" steel threaded drain pipe welded to the condensation tray.

Drainage pipes will be fitted for each tray through a siphon with a height difference of 80 mm. to avoid drainage problems from the depression formed by the fans. The pipes should have an inclination of 2% to ease drainage of condensation.

Also slightly tip the unit (2%) toward the drainage side. Check that the condensation trays are clean and free from dirt and other debris from the works and that water drains correctly.

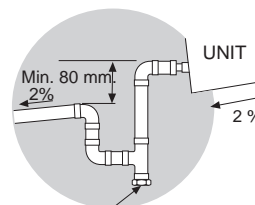

Inspection and cleaning stopper.

2.- INSTALLATION

2.6- REFRIGERANT CONNECTIONS

The unit is supplied with gas and liquid lines sealed with copper covers inside the casing with possibility to install pipe lines horizontal or vertical.

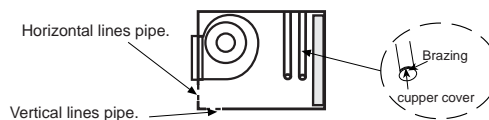

THE UNITS ARE SUPPLIED WITH NITROGEN GAS, THIS MUST BE REMOVED AND THEN PROCEED AS FOLLOW:

- 1° Remove the nitrogen gas, through the high and low 1/4" service ports, make vacuum as safety
 - 2° Remove the covers from connecting lines.
 - 3° Braze the piping connection lines.
- (When brazing refrigerant pipes, is necessary to supply nitrogen gas through the service ports into the pipes to remove the air).



DURING INSTALLATION OPERATIONS, KEEP GAS AND LIQUID PIPES COVERED, IN ORDER TO PREVENT HUMIDITY AND DIRT, GET INTO THEM.
TAKE SPECIAL CONCERN ABOUT REFRIGERANT PIPES ARE ISOLATED.
AVOID COLLAPSE ON PIPE LINES INSTALLATION.

- 128D unit models uses different sizes of pipe connections: big size for circuit 1 and small size for circuit 2.
- connect indoor unit circuits C1 and C2 to the corresponding C1 and C2 circuits of the outdoor units.

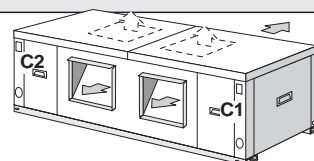

2.7- ELECTRICAL CONNECTIONS



- BEFORE MAKING ANY ELECTRICAL CONNECTIONS, BE SURE THAT ALL CIRCUIT BREAKERS ARE OPEN.
- IN ORDER TO CARRY OUT THE ELECTRICAL CONNECTIONS, FOLLOW THE ELECTRICAL DIAGRAM SUPPLIED WITH THE UNIT.

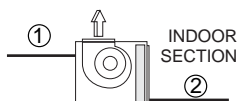

- ① Fan power supply.
- ② Electric battery supply.

FOR CLIMATIC 10 UNITS

ELECTRIC BATTERY
POWER SUPPLY 230V
SINGLE PHASE UNITS

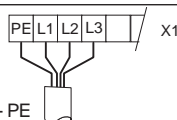

3 ~ 230V - 50 Hz + PE

ELECTRIC BATTERY
POWER SUPPLY 400V
SINGLE PHASE UNITS

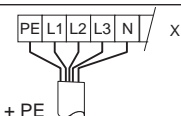

3N ~ 400V - 50 Hz + PE

UNIT MODEL	Nr. OF CABLES x SECTION (mm ²)				
	① Fan power supply	② Electric battery power supply		② Electric battery power supply	
		1 STAGE	2 STAGES	1 STAGE	2 STAGES
22E	4 x 1,5	4 x 10 + 5 x 1,5	-----	4 x 4 + 5 x 1,5	-----
24E	4 x 1,5	4 x 10 + 5 x 1,5	-----	4 x 4 + 5 x 1,5	-----
28E	4 x 1,5	4 x 10 + 5 x 1,5	-----	4 x 4 + 5 x 1,5	-----
32E	4 x 1,5	4 x 10 + 5 x 1,5	-----	4 x 4 + 5 x 1,5	-----
38E	4 x 1,5	4 x 10 + 5 x 1,5	-----	4 x 4 + 5 x 1,5	-----
43E	4 x 2,5	4 x 10 + 5 x 1,5	-----	4 x 4 + 5 x 1,5	-----
50E	4 x 2,5	4 x 10 + 5 x 1,5	-----	4 x 4 + 5 x 1,5	-----
56E	4 x 2,5	-----	-----	4 x 6 + 5 x 1,5	-----
76E	4 x 2,5	-----	-----	4 x 6 + 5 x 1,5	2 x (4 x 4) + 6 x 1,5
44D	4 x 2,5	4 x 16 + 5 x 1,5	2 x (4 x 10) + 6 x 1,5	4 x 6 + 5 x 1,5	2 x (4 x 4) + 6 x 1,5
48D	4 x 2,5	4 x 16 + 5 x 1,5	2 x (4 x 10) + 6 x 1,5	4 x 6 + 5 x 1,5	2 x (4 x 4) + 6 x 1,5
56D	4 x 2,5	4 x 16 + 5 x 1,5	2 x (4 x 10) + 6 x 1,5	4 x 6 + 5 x 1,5	2 x (4 x 4) + 6 x 1,5
64D	4 x 2,5	4 x 16 + 5 x 1,5	2 x (4 x 10) + 6 x 1,5	4 x 6 + 5 x 1,5	2 x (4 x 4) + 6 x 1,5
76D	4 x 2,5	4 x 16 + 5 x 1,5	2 x (4 x 10) + 6 x 1,5	4 x 6 + 5 x 1,5	2 x (4 x 4) + 6 x 1,5
86D	4 x 2,5	4 x 16 + 5 x 1,5	2 x (4 x 10) + 6 x 1,5	4 x 6 + 5 x 1,5	2 x (4 x 4) + 6 x 1,5
100D	4 x 2,5	4 x 16 + 5 x 1,5	2 x (4 x 10) + 6 x 1,5	4 x 6 + 5 x 1,5	2 x (4 x 4) + 6 x 1,5
112D	4 x 2,5	-----	-----	4 x 16 + 5 x 1,5	2 x (4 x 10) + 6 x 1,5
128D	4 x 2,5	-----	-----	4 x 16 + 5 x 1,5	2 x (4 x 10) + 6 x 1,5
152D	4 x 2,5	-----	-----	4 x 16 + 5 x 1,5	2 x (4 x 10) + 6 x 1,5

- The sections have been calculated for a length no longer than 50m and a voltage drop of 10V.
- Do not start the unit if the drop is greater than this.

FOR CLIMATIC 50 UNITS (only for models 56E-76E-112D-128D-152D)

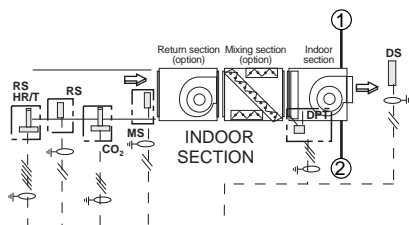

ELECTRIC BATTERY
POWER SUPPLY 400V
SINGLE PHASE UNITS

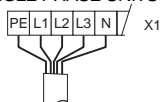

3N ~ 400V - 50 Hz + PE

UNIT MODEL	Nr. OF CABLES x SECTION (mm ²)		
	① Fan power supply	② Electric battery power supply	
		1 STAGE	2 STAGES
56E	4 x 2,5	4 x 6 + 5 x 1,5	-----
76E	4 x 2,5	4 x 6 + 5 x 1,5	2 x (4 x 4) + 6 x 1,5
112D	4 x 2,5	4 x 16 + 5 x 1,5	2 x (4 x 10) + 6 x 1,5
128D	4 x 2,5	4 x 16 + 5 x 1,5	2 x (4 x 10) + 6 x 1,5
152D	4 x 2,5	4 x 16 + 5 x 1,5	2 x (4 x 10) + 6 x 1,5

- ① Fan power supply.
- ② Electric battery supply.

- The sections have been calculated for a length no longer than 50m and a voltage drop of 10V.
- Do not start the unit if the drop is greater than this.

CONTROL CONNECTION ELEMENTS

COMPONENTS	STANDARD	DS (Discharge sensor)	Nr OF CABLES X SECTION (mm ²)
OPTIONS		MS (Duct sensor for thermostatic and enthalpic free cooling)	2 x 1 mm ² (shielded)
		RS (Duct sensor). It replaces AS	2 x 1 mm ² (shielded)
		RS HR/T (Duct remote sensor) for enthalpic free cooling	5 x 1 mm ² (shielded)
		CO ₂ (CO ₂ Air Quality Probe) available only with enthalpic free cooling	3 x 1 mm ² (shielded)
		DPT (Air differential pressure transducer)	3 x 1 mm ² (shielded)

NOTE: DS, RS y RS HR/T sensors are supplied inside the outdoor unit, perfectly identified. All these sensors have to be connected by the installer.

3.- COMMISSIONING AND OPERATION

3.1.- PRELIMINARY CHECKS

- ① Check that drain pipe connections and their fixtures are secure and that the level of the unit is tipped toward the drain.
- ② Inspect the state of the ducts and grilles (clean and open grilles, no breaks in the duct, etc.).
- ③ Check that the power supply is the same as stated on the Rating Plate which is in agreement with the electrical diagram for the unit and that cable sizes are correct.
- ④ Check that tightness of the electrical connections to their terminals and to ground.
Inspect the Air Filter, which should be in its housing and correctly positioned (the metal grille should be toward the inside).
- ⑤ Check **with your hand** that the fan turns freely.

SKETCH FOR THE STANDARD UNIT CONFIGURATION IN DOUBLE CIRCUIT UNITS

LOCATION

The unit can be installed outside. If it is installed, air entry and exit ducts should be fitted. The indoor unit should be assembled on bases previously made and stood on absorbent and antivibrating material to avoid the vibrations being transmitted to the structure of the building.

DISCHARGE IN THE MODELS UNITS 44D-48D-56D-64D-76D

Always to be done through a common duct or plenum.

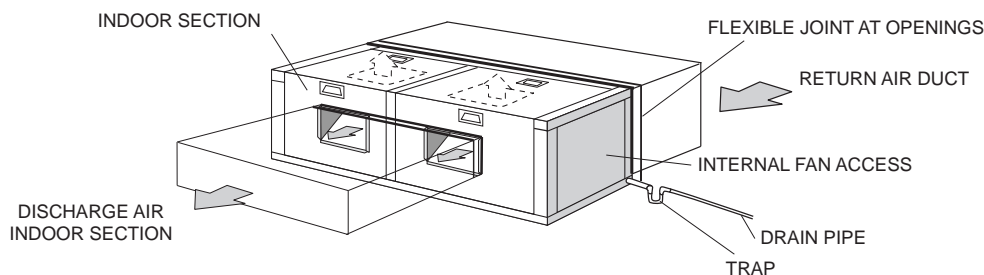

4.- MAINTENANCE

4.1.- PREVENTIVE MAINTENANCE



PREVENTIVE MAINTENANCE PREVENTS COSTLY REPAIRS. BECAUSE OF THIS PERIODIC INSPECTIONS ARE REQUIRED.

-GENERAL STATE OF THE CASING:

Furniture, paint, deterioration due to bumps, rust spots, leveling and supporting, state of the shock absorbers, if installed, screwed panels, etc.

- ELECTRICAL CONNECTIONS:

State of hoses, tightness of screws, grounding, current draw of the compressor and fans and checking that the unit is receiving the correct voltage.

- COOLING CIRCUIT:

Check that pressure values are correct and that there are no leaks. Check that there is no damage to the pipe insulation, that the state of the batteries is correct and that there are no chips or clogs retained by the air flow, etc.

- DRAINS:

Check that water drains correctly and that the drain trays are clean.

- FAN:

Check that fans turn freely and in the correct direction without excessive noises.

- AIR FILTER :

The air filter can be removed through the side by sliding it over the rail or down. (See figure).

For down removal, remove the two profiles supporting it (depending on the model) which are under the filter guide rail and screwed into the unit.

In models 112D/128D/152D filters have to be extracted by both sides (2 filters by side).

The filter should be cleaned with a vacuum cleaner or washed in soapy water.

The frequency for cleaning or changing the air filters will depend on the quality air in the area (fumes, vapors, suspended dust particles, etc.).

Remember that the metal grille should always be toward the inside of the unit.

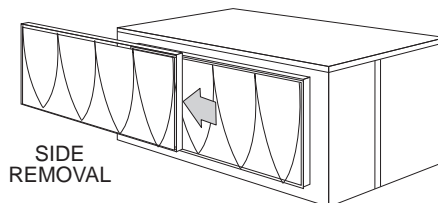

Remember that the Control Panel may program a notification parameter, for cleaning or replacement of air filters depending on the number of hours of fan operation in the indoor section.



www.lennox europe.com

BELGIUM, LUXEMBOURG
www.lennoxbelgium.com

CZECH REPUBLIC
www.lennox.cz

FRANCE
www.lennoxfrance.com

GERMANY
www.lennoxdeutschland.com

GREAT BRITAIN
www.lennoxuk.com

NETHERLANDS
www.lennoxnederland.com

POLAND
www.lennoxpolska.com

PORTUGAL
www.lennoxportugal.com

RUSSIA
www.lennoxrussia.com

SLOVAKIA
www.lennoxdistribution.com

SPAIN
www.lennoxspain.com

UKRAINE
www.lennoxrussia.com

OTHER COUNTRIES
www.lennoxdistribution.com

Due to Lennox's ongoing commitment to quality, the Specifications, Ratings and Dimensions are subject to change without notice and without incurring liability.

Improper installation, adjustment, alteration, service or maintenance can cause property damage or personal injury.

Installation and service must be performed by a qualified installer and servicing agency.



MIL79E-0805 09-2006