

Installation, operating and maintenance **COMPACTAIR - CIC/CIH**

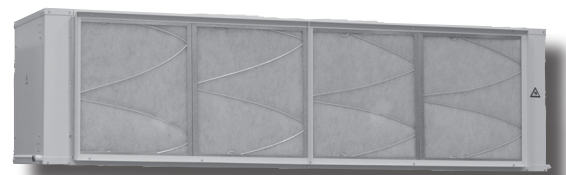

- Providing indoor climate comfort



WARNING: Read this manual before carrying out installation, repair or maintenance work.

TABLE OF CONTENTS

POINTS TO BEAR IN MIND	PAGE 2
DATA PAGE FOR COMMISSIONING OF THE UNIT	PAGE 3
1.- GENERAL CHARACTERISTICS	PAGE
1.1.- PHYSICAL DATA	4
1.2.- ELECTRICAL DATA	4-5
1.3.- FAN PERFORMANCE	5-8
1.4.- UNIT DIMENSIONS	9
2.- 2.- INSTALLATION	PAGE
2.1.- INSTALLATION GUIDELINES	10
2.2.- OPTIONAL TASK PRIOR TO UNIT INSTALLATION: REGULATING AIRFLOW IN THE FANS	10
2.3.- SERVICE SPACE	11
2.4.- DRAINAGE	11
2.5.- REFRIGERANT CONNECTIONS	11
2.6.- ELECTRICAL CONNECTIONS	12
2.7.- INSTALLATION OF OPTIONS	13-20
3.- COMMISSIONING AND OPERATION	PAGE
3.1.- PRELIMINARY CHECKS	21
4.- MAINTENANCE	PAGE
4.1.- PREVENTIVE MAINTENANCE	21
4.2.- FAULT DIAGNOSIS	22

Lennox have been providing environmental solutions since 1895. Our AIRCOOLAIR range continues to meet the standards that have made LENNOX a household name; flexible design solutions to meet your needs and uncompromising attention to detail; engineered to last, simple to maintain and quality that comes as standard. For information on local contacts go to www.lennox europe.com.

All the technical and technological information contained in this manual, including any drawings and technical descriptions provided by us, remain the property of Lennox and must not be utilised (except in the operation of this product), reproduced, issued to or made available to third parties without the prior written agreement of Lennox.

POINTS TO BEAR IN MIND

DANGER AND WARNING SIGNS



Abrasive surfaces



Low temperatures



High temperatures



Risk of injury from moving objects



Electrical voltage



Risk of injury from rotating objects

ELECTRICAL CONNECTIONS



To prevent serious electrical injuries, make sure to switch off the power before doing any installation, repair or maintenance work on the unit.

To install the unit, bear in mind local and national legislation.

ATTENTION - WARNING

Electric shock can cause injury or death. Before attempting to perform any service or maintenance on the unit, turn OFF the electrical power, and check that the fan has stopped.

The air filter cleaning operations does not require technical service; however, when an electrical or mechanical operation is required, call an Engineer.

CLEANING THE FILTER

Check the air filter and make sure it is not blocked with dust or dirt.

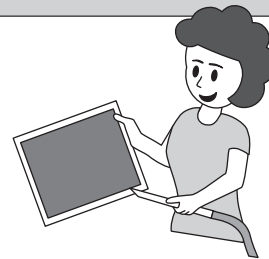
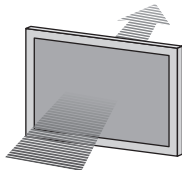

If the filter is dirty, wash it in a bowl with neutral soap and water, drying it in the shade before re-inserting it in the unit.

Standard Guidelines for Lennox equipment.

All technical data contained in these operating instructions, including diagrams and technical descriptions, remain the property of Lennox and may not be used (except for the purpose of familiarizing the user with the equipment), reproduced, photocopied, transferred or transmitted to third parties without prior written authorization from Lennox.

Data published in the operating instructions are based on the latest information available. We reserve the right to make modifications without notice.

We reserve the right to modify our products without notice and with no obligation to modify goods previously supplied.

These operating instructions contain useful and important information for the smooth operation and maintenance of your equipment.

The instructions also include guidelines on how to avoid accidents and serious damage before commissioning the equipment and during its operation and how to ensure smooth and fault-free operation. Read the operating instructions carefully before starting the equipment, familiarize yourself with the equipment and with handling the installation and carefully follow the instructions. It is very important to be properly trained in handling the equipment. These operating instructions must be kept in a safe place near the equipment.

Like most equipment, the unit requires regular maintenance. This section concerns maintenance personnel and management. If you have any queries or would like to receive further information on any aspect relating to your equipment, do not hesitate to contact us.

DATA PAGE FOR UNIT COMMISSIONING

UNIT: _____ SERIAL Nr.: _____

CONTROL PANEL IDENTIFICATION CODE _____

INSTALLATION ADDRESS: _____

INSTALLER: _____ INSTALLER TEL: _____

INSTALLER ADDRESS: _____

DATE COMMISSIONING: _____

CHECKS:

SUPPLY VOLTAGE: _____ RATED VOLTAGE OF THE UNIT: _____

YES NO

DRAINAGE WITH TRAP.

CLEAN INTERIOR AIR FILTER.

GENERAL POWER SUPPLY CONNECTION.

DATA INPUT:

COLD CYCLE

HEATING CYCLE

Air flow data: _____

Air flow data: _____

Air Intake Temperature, Indoor Coil: _____ °C

Air Intake Temperature, Indoor Coil: _____ °C

High Pressure: _____

High Pressure: _____

Low Pressure: _____

Low Pressure: _____

ELECTRIC POWER CONSUMPTION (Amps)

Fan indoor section: _____ / _____ / _____

Fan indoor section: _____ / _____ / _____

Options Installed: _____

Comments: _____

1.- GENERAL CHARACTERISTICS

1.1.- PHYSICAL DATA

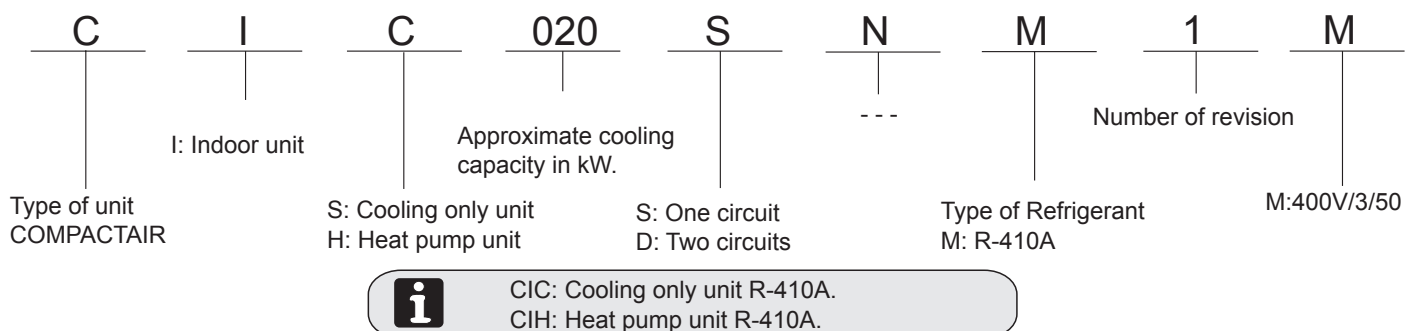

WEIGHT FOR STANDARD UNITS AND OPTIONS

UNIT MODELS	CIC CIH	020 S	025 S	030 S	035 S	040 S	045 D	055 D	070 D	085D	100D
Indoor unit CIC/CIH	Kg	108	111	115	150	160	170	242	259	276	470
Airsock control	Kg	2	2	2	2	2	2	2	3	3	3
Electrical heater	Kg	10	10	10	10	10	20	20	20	30	45
Free-cooling	Kg	50	50	50	75	75	75	165	165	165	190
Hot water coil	Kg	10	10	10	12	16	20	20	24	30	40
Kit of ventilation HP1	Kg	6,5	3	3	5	0	3	3	3	13	13
Kit of ventilation HP2	Kg	6,5	3	8	8	3	6	6	16	21	27
Kit of ventilation HP3	Kg	9,5	8	11	8	6	6	19	24	21	27
Exhaust fan	Kg	25	25	25	28	28	28	37	37	37	65
Return fan	Kg	n/a	n/a	n/a	n/a	n/a	n/a	145	145	145	230
High efficiency air filter (G4 prefilter/F7 filtration)	Kg	6	6	6	9	9	9	14	14	14	23

1.2.- ELECTRICAL DATA

ELECTRICAL CONSUMPTION FOR STANDARD UNITS

UNIT MODELS	CIC CIH	020 S	025 S	030 S	035 S	040 S	045 D	055 D	070 D	085D	100D
Maximum absorbed power	Kw	0.74	1.45	1.45	1.89	2.69	2.69	2.69	3.63	5.06	5.06
Maximum current	A	1.40	2.59	2.59	3.45	4.80	4.80	4.80	6.48	8.60	8.60
Start up current	A	6.44	13.0	13.0	17.3	26.4	26.4	26.4	35.6	60.2	60.2
Voltage	PhV/Hz	3N~400V 50Hz									

ADDITIONAL ELECTRICAL CONSUMPTION FOR THE OPTIONS (CIC/H 020S-040S)

	CIC/H 020S		CIC/H 025S		CIC/H 030S		CIC/H 035S		CIC/H 040S	
	Maximum absorbed power (Kw)	Maximum current (A)	Maximum absorbed power (Kw)	Maximum current (A)	Maximum absorbed power (Kw)	Maximum current (A)	Maximum absorbed power (Kw)	Maximum current (A)	Maximum absorbed power (Kw)	Maximum current (A)
Ventilador interior estándar	0	0	0	0	0	0	0	0	0	0
Kit de ventilación HP1	0,71	1,19	0,44	0,86	44	0,86	0,8	1,35	0	0
Kit de ventilación HP2	0,71	1,19	1,24	2,21	1,24	2,21	1,74	3,03	0,94	1,68
Kit de ventilación HP3	1,15	2,05	1,24	2,21	2,18	3,89	1,74	3,03	2,37	3,8
Ventilador de extracción	0,51	2,6	0,51	2,6	0,51	2,6	1,33	6,8	1,33	6,8
Ventilador de retorno	n/a	n/a	n/a	n/a	n/a	n/a	n/a	n/a	n/a	n/a
Batería eléctrica estándar	10	14,3	10	14,3	10	14,3	15	21,5	15	21,5
Batería eléctrica media	15	21,5	15	21,5	15	21,5	20	28,6	20	28,6
Batería eléctrica alta	20	28,6	20	28,6	20	28,6	27	39	27	39

1.- GENERAL CHARACTERISTICS

1.2.- ELECTRICAL DATA

ADDITIONAL ELECTRICAL CONSUMPTION FOR THE OPTIONS (CIC/H 045D-100D)

	CIC/H 045D		CIC/H 055D		CIC/H 070D		CIC/H 085D		CIC/H 100D	
	Maximum absorbed power (Kw)	Maximum current (A)	Maximum absorbed power (Kw)	Maximum current (A)	Maximum absorbed power (Kw)	Maximum current (A)	Maximum absorbed power (Kw)	Maximum current (A)	Maximum absorbed power (Kw)	Maximum current (A)
Ventilador interior estándar	0	0	0	0	0	0	0	0	0	0
Kit de ventilación HP1	0,94	1,68	0,94	1,68	1,43	2,12	1,32	2,5	1,32	2,5
Kit de ventilación HP2	2,37	3,8	2,37	3,8	2,75	4,62	3,73	6,7	5,06	8,6
Kit de ventilación HP3	2,37	3,8	3,69	3,69	5,16	8,82	3,73	6,7	5,06	8,6
Ventilador de extracción	1,33	6,8	2,65	4,5	2,65	4,5	2,65	4,5	5,3	9
Ventilador de retorno	n/a	n/a	2,69	4,8	3,63	6,5	3,63	6,5	5,06	8,6
Batería eléctrica estándar	15	21,5	20	28,6	20	28,6	20	28,6	27	39
Batería eléctrica media	20	28,6	27	39	27	39	27	39	40	57,8
Batería eléctrica alta	27	39	40	57,8	40	57,8	40	57,8	50	72,3

1.3.- FAN PERFORMANCES

1.3.1.- STANDARD FAN PERFORMANCES

		CLOSED PULLEY	1 TURN	2 TURNS	3 TURNS	4 TURNS
		020S	rpm	824	788	753
	m3/h	Available static pressure Pa.				
	3150	167	149	132	116	101
	3425	162	143	127	109	93
	3700	155	138	120	103	85
	4100	●	127	108	90	72
025S	rpm	824	788	753	717	682
	m3/h	Available static pressure Pa.				
	4250	141	123	103	84	66
	4625	129	109	89	69	49
	5000	115	92	71	50	28
	5500	89	66	42	19	n/a
030S	rpm	915	876	836	797	757
	m3/h	Available static pressure Pa.				
	4650	173	149	125	103	80
	5050	158	133	109	84	60
	5450	141	115	89	63	38
	6000	●	84	56	28	0
035S	rpm	735	704	672	640	609
	m3/h	Available static pressure Pa.				
	6200	164	142	119	98	77
	6650	153	130	106	83	61
	7100	139	114	89	66	42
	8050	102	75	48	22	n/a
040S	rpm	837	792	748	704	659
	m3/h	Available static pressure Pa.				
	6950	213	178	143	109	75
	7550	196	158	122	86	50
	8150	175	136	97	58	21
	9050	136	94	53	10	n/a

		CLOSED PULLEY	1 TURN	2 TURNS	3 TURNS	4 TURNS
		045D	rpm	937	888	838
	m3/h	Available static pressure Pa.				
	7950	272	227	183	140	97
	8675	249	201	155	109	63
	9400	●	171	121	72	23
	9750	●	●	103	51	1
055D	rpm	837	792	748	704	659
	m3/h	Available static pressure Pa.				
	9950	206	177	148	122	96
	10825	195	166	138	110	83
	11700	185	154	125	97	68
	12850	●	136	105	75	45
070D	rpm	937	888	838	788	738
	m3/h	Available static pressure Pa.				
	12450	237	200	163	128	95
	13550	●	183	145	109	73
	14650	●	●	124	85	48
	15090	●	●	115	75	36
085D	rpm	937	888	838	788	738
	m3/h	Available static pressure Pa.				
	14000	202	163	125	87	51
	15125	182	142	102	62	23
	16250	160	117	75	34	n/a
	16725	149	105	63	20	n/a
100D	rpm	750	710	670	630	591
	m3/h	Available static pressure Pa.				
	17350	237	202	167	133	101
	18875	223	185	149	115	81
	20400	●	168	131	94	59
	22450	●	●	100	63	25

(●) WRONG STATUS ON ACCOUNT OF MOTOR POWER LIMIT.

□ NOMINAL FACTORY SETTING.

NOTE: With low distance option it is not suitable unit working below nominal air flow.

1.- GENERAL CHARACTERISTICS

1.3.- FAN PERFORMANCES

1.3.2.- FAN PERFORMANCES WITH KIT HIGH STATIC PRESSURE (OPTIONAL TRANSMISSION)

VENTILATION HP1

		CLOSED PULLEY	1 TURN	2 TURNS	3 TURNS	4 TURNS
020S	rpm	1098	1051	1003	956	909
	m3/h	Available static pressure Pa.				
	3150	324	294	264	237	211
	3425	321	289	261	233	207
	3700	317	285	257	229	202
	4100	310	279	249	222	193
025S	rpm	1098	1051	1003	956	909
	m3/h	Available static pressure Pa.				
	4250	308	276	246	218	190
	4625	301	269	239	209	180
	5000	292	260	228	197	167
	5500	278	244	211	178	146
030S	rpm	1098	1051	1003	956	909
	m3/h	Available static pressure Pa.				
	4650	290	259	228	198	169
	5050	280	248	215	184	154
	5450	269	235	201	169	138
	6000	249	213	178	143	109
035S	rpm	937	888	838	788	738
	m3/h	Available static pressure Pa.				
	6200	321	281	241	203	167
	6650	313	272	232	193	155
	7100	306	262	221	181	142
	8050	282	236	191	148	105
040S	rpm	937	888	838	788	738
	m3/h	Available static pressure Pa.				
	6950	298	255	214	174	135
	7550	283	240	197	155	113
	8150	267	221	176	132	88
	9050	●	186	138	90	43

		CLOSED PULLEY	1 TURN	2 TURNS	3 TURNS	4 TURNS
045D	rpm	1041	986	931	876	820
	m3/h	Available static pressure Pa.				
	7950	371	318	267	217	168
	8675	353	298	244	190	139
	9400	330	271	215	158	103
	9750	316	258	199	141	84
055D	rpm	1041	986	931	876	820
	m3/h	Available static pressure Pa.				
	9950	357	313	272	232	194
	10825	349	304	263	223	185
	11700	●	295	253	213	173
	12850	●	●	239	196	156
070D	rpm	1041	986	931	876	820
	m3/h	Available static pressure Pa.				
	12450	321	276	232	191	151
	13550	307	262	217	174	133
	14650	291	244	199	154	110
	15090	●	236	190	145	101
085D	rpm	1041	986	931	876	820
	m3/h	Available static pressure Pa.				
	14000	288	242	197	155	112
	15125	272	223	177	132	88
	16250	253	203	154	107	60
	16725	244	193	144	95	48
100D	rpm	837	792	748	704	659
	m3/h	Available static pressure Pa.				
	17350	323	279	236	196	157
	18875	310	264	221	180	140
	20400	296	248	204	162	121
	22450	●	●	178	133	90

VENTILATION HP2

		CLOSED PULLEY	1 TURN	2 TURNS	3 TURNS	4 TURNS
020S	rpm	1177	1126	1075	1024	974
	m3/h	Available static pressure Pa.				
	3150	377	342	309	278	247
	3425	373	338	306	273	243
	3700	369	334	302	269	239
	4100	364	329	295	263	232
025S	rpm	1318	1261	1204	1147	1091
	m3/h	Available static pressure Pa.				
	4250	466	423	381	341	303
	4625	461	418	375	335	295
	5000	●	412	368	327	287
	5500	●	●	●	314	273

		CLOSED PULLEY	1 TURN	2 TURNS	3 TURNS	4 TURNS
030S	rpm	1339	1268	1197	876	1055
	m3/h	Available static pressure Pa.				
	4650	468	413	359	309	261
	5050	462	405	352	299	250
	5450	454	396	341	289	238
	600	441	383	325	270	216
035S	rpm	1103	1044	986	927	869
	m3/h	Available static pressure Pa.				
	6200	469	414	362	313	266
	6650	463	408	356	305	257
	7100	458	402	348	297	247
	8050	442	383	327	272	220

(●) WRONG STATUS ON ACCOUNT OF MOTOR POWER LIMIT.

□ NOMINAL FACTORY SETTING.

NOTE: With low distance option it is not suitable unit working below nominal air flow.

1.- GENERAL CHARACTERISTICS

1.3.- FAN PERFORMANCES VENTILATION HP2

		CLOSED PULLEY	1 TURN	2 TURNS	3 TURNS	4 TURNS
040S	rpm	1103	1044	986	927	869
	m3/h	Available static pressure Pa.				
	6950	449	393	340	289	239
	7550	440	382	327	275	223
	8150	427	370	312	257	203
	9050	405	344	284	225	168
045D	rpm	1103	1044	986	927	869
	m3/h	Available static pressure Pa.				
	7950	432	373	317	263	211
	8675	415	355	296	240	184
	9400	395	332	271	211	152
	9750	384	320	256	195	134
055D	rpm	1172	1109	1047	985	923
	m3/h	Available static pressure Pa.				
	9950	514	456	399	346	296
	10825	508	448	391	338	286
	11700	500	440	383	328	275
	12850	●	●	369	313	258

		CLOSED PULLEY	1 TURN	2 TURNS	3 TURNS	4 TURNS
070D	rpm	1172	1109	1047	985	923
	m3/h	Available static pressure Pa.				
	12450	371	421	363	307	252
	13550	470	408	348	289	233
	14650	457	391	329	268	208
	15090	450	383	320	258	196
085D	rpm	1172	1109	1047	985	923
	m3/h	Available static pressure Pa.				
	14000	452	390	328	268	211
	15125	438	371	307	245	183
	16250	418	349	282	215	150
	16725	408	338	270	202	135
100D	rpm	937	888	838	788	738
	m3/h	Available static pressure Pa.				
	8675	477	419	364	312	262
	9437	469	410	354	299	248
	10200	458	398	341	284	232
	11225	440	379	319	261	206

VENTILATION HP3

		CLOSED PULLEY	1 TURN	2 TURNS	3 TURNS	4 TURNS
020S	rpm	1318	1261	1204	1147	1091
	m3/h	Available static pressure Pa.				
	3150	483	438	397	357	319
	3425	478	434	393	353	316
	3700	474	430	389	349	312
	4100	469	425	383	343	305
025S	rpm	1500	1420	1340	1261	1181
	m3/h	Available static pressure Pa.				
	4250	●	550	485	423	365
	4625	●	545	480	418	359
	5000	●	541	475	412	352
	5500	●	532	466	402	339
030S	rpm	1500	1420	1340	1261	1181
	m3/h	Available static pressure Pa.				
	4650	●	535	469	408	349
	5050	●	529	463	399	340
	5450	●	521	455	391	330
	6000	●	511	443	376	313
035S	rpm	1250	1183	1117	1051	985
	m3/h	Available static pressure Pa.				
	6200	●	548	483	421	362
	6650	●	545	478	415	355
	7100	●	539	472	408	347
	8050	●	526	456	390	326
040S	rpm	1250	1183	1117	1051	985
	m3/h	Available static pressure Pa.				
	6950	602	530	463	399	339
	7550	594	522	453	388	326
	8150	586	512	442	376	311
	9050	570	493	421	351	283

		CLOSED PULLEY	1 TURN	2 TURNS	3 TURNS	4 TURNS
045D	rpm	1250	1183	1117	1051	985
	m3/h	Available static pressure Pa.				
	7950	589	515	446	381	317
	8675	578	501	430	363	295
	9400	562	485	411	340	270
	9750	553	475	400	326	255
055D	rpm	1339	1268	1197	1126	1055
	m3/h	Available static pressure Pa.				
	9950	689	612	539	471	406
	10825	683	606	533	464	398
	11700	677	599	525	457	390
	12850	670	590	515	444	376
070D	rpm	1339	1268	1197	1126	1055
	m3/h	Available static pressure Pa.				
	12450	662	582	508	437	370
	13550	652	573	497	424	354
	14650	641	561	484	408	336
	15090	636	555	477	400	328
085D	rpm	1339	1268	1197	1126	1055
	m3/h	Available static pressure Pa.				
	14000	636	557	478	406	336
	15125	623	542	464	387	315
	16250	609	526	445	367	289
	16725	602	518	436	357	279
100D	rpm	1041	986	931	876	820
	m3/h	Available static pressure Pa.				
	8675	606	537	469	407	346
	9437	599	529	461	396	334
	10200	592	519	451	384	321
	11225	●	504	433	364	299

(●) WRONG STATUS ON ACCOUNT OF MOTOR POWER LIMIT.
 NOMINAL FACTORY SETTING.

NOTE: With low distance option it is not suitable unit working below nominal air flow.

1.- GENERAL CHARACTERISTICS

1.3.3.- FAN PERFORMANCES WITH FREE-COOLING

Return fan performances for each models are:

		055E					070E						
AIR FLOW		m ³ /h	9950	10825	11700	12850	m ³ /h	12450	13550	14650	15090		
		r.p.m	Available static pressure Pa.					r.p.m	Available static pressure Pa.				
PULLEY MOTOR POSITION	CLOSED PULLEY	755	255	257	260	260	755	260	260	258	255		
	1 TURN	715	230	232	234	233	715	235	233	228	225		
	2 TURNS	675	207	208	210	207	675	208	205	198	195		
	3 TURNS	635	184	184	184	180	635	182	176	168	165		
	4 TURNS	595	162	162	160	155	595	157	150	140	135		

		085D					100D						
AIR FLOW		m ³ /h	14000	15125	16250	16725	m ³ /h	17350	18875	20400	22450		
		r.p.m	Available static pressure Pa.					r.p.m	Available static pressure Pa.				
PULLEY MOTOR POSITION	CLOSED PULLEY	755	260	255	250	●	672	293	293	291	●		
	1 TURN	715	230	225	215	212	636	263	261	258	251		
	2 TURNS	675	202	195	183	178	601	234	232	227	218		
	3 TURNS	635	173	165	153	145	565	205	202	196	185		
	4 TURNS	595	145	135	120	115	529	178	173	166	153		

● WRONG STATUS ON ACCOUNT OF MOTOR POWER LIMIT.

NOTE: With low distance option it is not suitable unit working below nominal air flow.

□ NOMINAL FACTORY SETTING.

Air flows with exhaust fan for option “free-cooling without return fan”

020S-025S-030S

AIR FLOW	m ³ /h	2000	2500	2750
AVAILABLE STATIC PRESSURE Pa.		160	105	75

035S-040S-045D

m ³ /h	3000	3500	4000
AVAILABLE STATIC PRESSURE Pa.	210	180	130

055D-070D-085D

AIR FLOW	m ³ /h	6000	7000	8000
AVAILABLE STATIC PRESSURE Pa.		260	200	90

100D

m ³ /h	13200	14300	15400	16500
AVAILABLE STATIC PRESSURE Pa.	230	200	150	50

1.- GENERAL CHARACTERISTICS

1.5.- UNIT DIMENSIONS

MODELS 020S-025S-030S

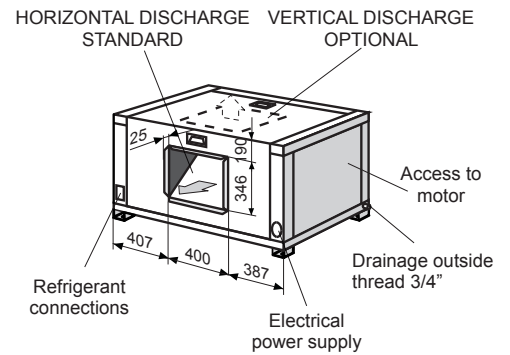
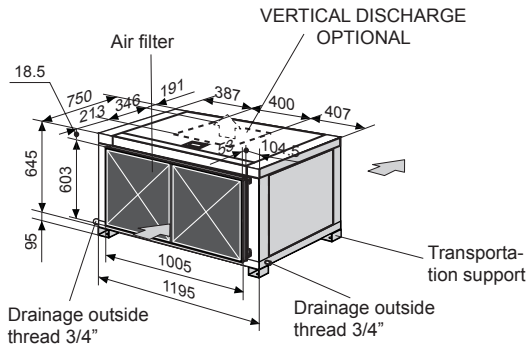

MODELS 035S-040S-045D

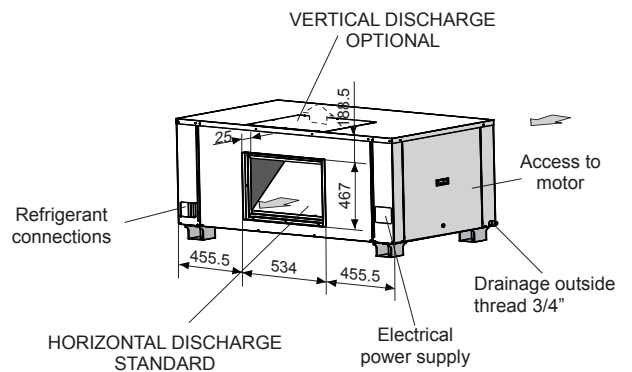
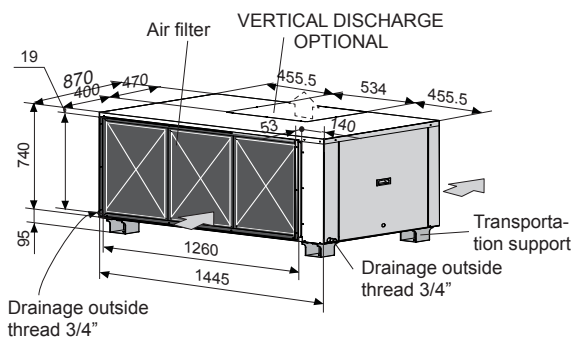

MODELS 055D-070D-085D

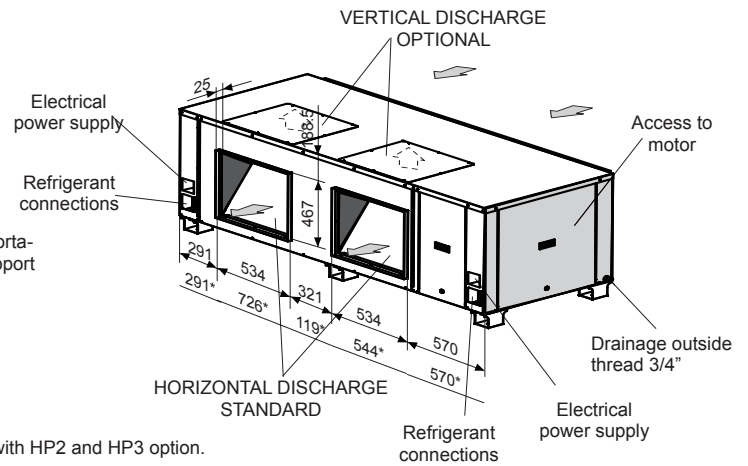
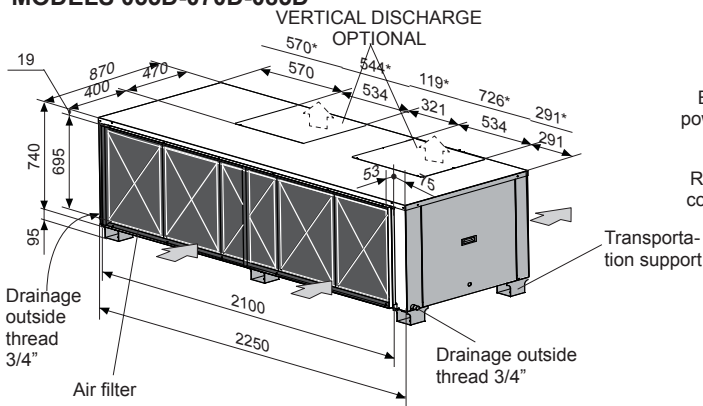

* Values with HP2 and HP3 option.

MODELS 100D

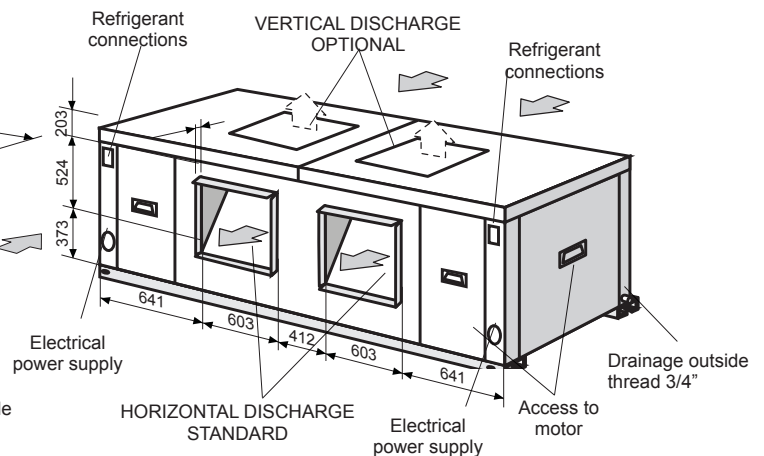
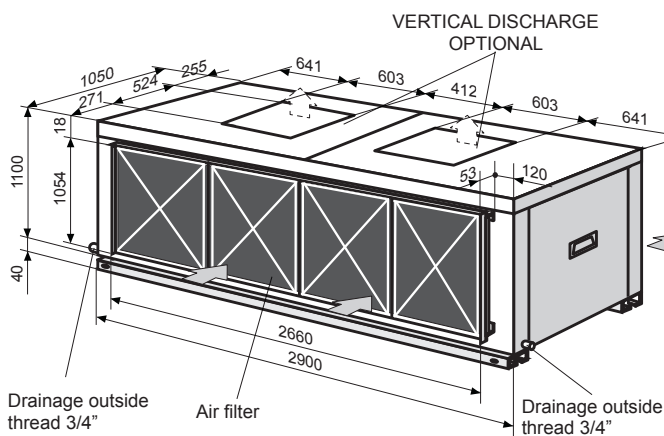

2.- INSTALLATION

2.1.- INSTALLATION GUIDELINES



ALL INSTALLATION, SERVICE and MAINTENANCE operations must be carried out by QUALIFIED PERSONNEL.

The unit must be transported in a HORIZONTAL POSITION on its metal legs. Any other position may cause serious damage to the machine. When the unit is received, it should be checked to ensure that there are no knocks or other damage, following the instructions on the packaging. If there is damage, the unit may be rejected by notifying the LENNOX Distribution Department and explaining on the transport agent's delivery notice why the machine is unacceptable. Any complaint or claim made subsequently to the LENNOX Distribution Department for this type of anomaly cannot be considered under the Guarantee.

Sufficient space must be allowed to facilitate placement of the unit.



When positioning the unit, be sure that the Rating Plate will always be visible since this data will be necessary to assure proper maintenance.

The units are designed to be installed with ducts, calculated by qualified technical staff. The joints to be used between ducts and the openings to the unit should be Elastic Joints. Avoid the use of BYPASS joints between the extraction air and input air in both the outdoor and indoor sections. The structure where the unit is placed must be able to support the weight of the unit during operation.

If there are problems of height, the transport supports can be removed by unscrewing them from the base. (Units 020S to 085D).

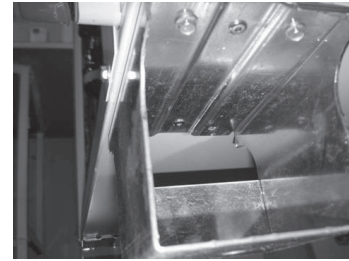

2.2.- OPTIONAL OPERATIONS PRIOR TO UNIT INSTALLATION:

VENTILATION FOR CIC-CIH UNITS IS PROVIDED BY:

- 1.- Centrifugal fan (single or double).
- 2.- Drive motor.
- 3.- Pulley fixed to the fan.
- 4.- Adjustable pulley on the fan motor.
- 5.- Pulley belt.
- 6.- Base of the motor with displacement system for tensioning belts.
- 7.- Tensioning screw.

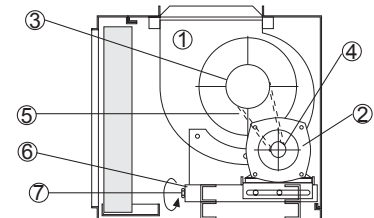

REGULATING AIRFLOW AT THE FANS

The unit fan has an adjustable pulley on the drive motor so that, when the fan is switched off, the pulley diameter can be adjusted to modify the unit's air flow, as required.

1. Fixed part.
2. Moving part.
3. Fixing screw.

CLOSE PULLEY:

To increase the air flow from the fan, turn the moving part in direction "B". (Clockwise).

OPEN PULLEY:

To reduce airflow, turn in direction "A". (Anticlockwise).

SIMPLE PULLEY

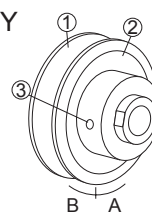

ADJUSTABLE PULLEYS

DOBLE PULLEY

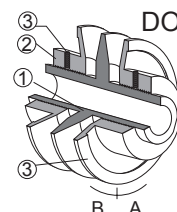

TENSION OF BELTS

The belts can be easily tensioned by means of the tensioning screw incorporated into the base of the motor in the transmission unit, which also makes it easy to carry out servicing properly. When the tensioning screw is turned, the fan motor is moved sideways in order to tension the pulley.

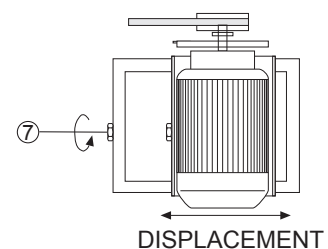

2.- INSTALLATION

2.3.- SERVICE SPACE

Free space should be left to enable access for servicing, in order to check the installation of the cables, drainage connections, electrical installation and cleaning filters, as well as to give easy access to the unit.

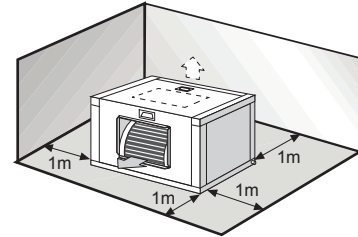

2.4.- DRAINAGE

All units have a 3/4" steel threaded drainage pipe welded to the condensation tray.

Drainage pipes will be fitted for each tray through a siphon with a height difference of 80 mm. to avoid drainage problems from the depression formed by the fans. The pipes should have a 2% slope to enable condensation to be drained easily.

Also tip the unit slightly (2%) toward the drainage side. Check that the condensation trays are clean and free of dirt and other debris from the installation work and that water drains correctly.

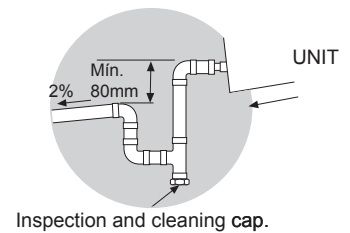

2.5.- REFRIGERANT CONNECTIONS

The unit is supplied with gas and liquid lines, sealed with copper caps.



THE UNITS ARE SUPPLIED WITH NITROGEN GAS. THIS MUST BE REMOVED BEFORE PROCEEDING AS FOLLOWS:

- 1 Remove the nitrogen gas through the top and bottom 5/16" service ports, leaving a vacuum as a safety measure.
 - 2 Remove the caps from the connecting pipes.
 - 3 Braze the connecting pipes.
- (When brazing refrigerant pipes, nitrogen gas must be supplied through the service ports into the pipes to remove any air).



DURING INSTALLATION OPERATIONS, KEEP GAS AND LIQUID PIPES COVERED, IN ORDER TO PREVENT HUMIDITY AND DIRT FROM GETTING INTO THEM. TAKE SPECIAL CARE TO ENSURE THAT REFRIGERANT PIPES ARE INSULATED. AVOID COLLAPSE ON PIPE LINES INSTALLATION.

- 100D unit model uses different sizes of pipe connections: big size for circuit 1 and small size for circuit 2.

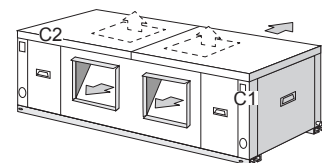

Please be sure to connect indoor unit circuits C1 and C2 to the corresponding C1 and C2 circuits of the outdoor unit.

2.- INSTALLATION

2.6.- ELECTRICAL CONNECTIONS



- BEFORE MAKING ANY ELECTRICAL CONNECTIONS, BE SURE THAT ALL CIRCUIT BREAKERS ARE OPEN.
- IN ORDER TO CARRY OUT THE ELECTRICAL CONNECTIONS, FOLLOW THE ELECTRICAL DIAGRAM SUPPLIED WITH THE UNIT.

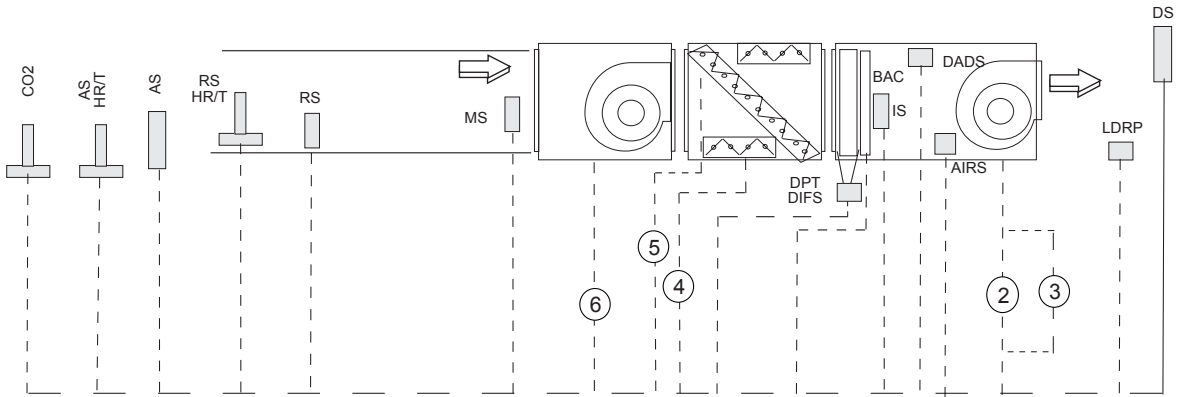

POWER SUPPLY

----- To connect by installer

POWER SUPPLY									
	FAN 2	ELECTRICAL HEATER 3				FREE-COOLING 4		EXHAUST FAN 5	RETURN FAN 6
		STANDARD	MEDIUM	HIGH	MODULATING	STD (C40)	C50		
020S	4 x 1,5 mm ²	4 x 2,5 mm ²	4 x 4 mm ²	4 x 6 mm ²	4 x 6 mm ²	5 x 1,5mm ²	7 x 1,5mm ²	3 x 1,5mm ²	N/A
025S		+	+	+	+				
030S		6 x 1,5 mm ²	6 x 1,5 mm ²	6 x 1,5 mm ²	7 x 1,5 mm ²				
035S	4 x 1,5 mm ²	4 x 4 mm ²	4 x 6 mm ²	4 x 10 mm ²	4 x 10 mm ²				
040S		+	+	+	+				
045S		6 x 1,5 mm ²	6 x 1,5 mm ²	6 x 1,5 mm ²	7 x 1,5 mm ²				
055D	4 x 1,5 mm ² (STD/HP1)	4 x 6 mm ²	3 x 10 mm ² +PE	4 x 16 mm ²	4 x 16 mm ²	4 x 1,5mm ²	4 x 1,5mm ²	4 x 1,5mm ²	4 x 1,5mm ²
070D	+	+	+	+					
085D	4 x 2,5 mm ² (HP1/HP2)	6 x 1,5 mm ²	6 x 1,5 mm ²	6 x 1,5 mm ²	7 x 1,5 mm ²				
100D	4 x 2,5 mm ² (STD/HP1) 2 x (4 x 1,5 mm ²) (HP1/HP2)	4 x 10 mm ² +	4 x 16 mm ² +	4 x 25 mm ² +	4 x 25 mm ² +	7 x 1,5 mm ²	4 x 2,5mm ²	4 x 2,5mm ²	4 x 2,5mm ²

CONNECTION OF CONTROL ELEMENTS:

COMPONENT		VERSION		Nr. CABLES x SECTION	
		STANDARD (C40)	C50	STANDARD (C40)	C50
DS	Discharge sensor		STANDARD		2 x 1 mm ² (shielded)
AS	Remote ambient sensor	OPTION	STANDARD	2 x 1 mm ² (shielded)	
RS	Remote duct sensor	OPTION	OPTION	2 x 1 mm ² (shielded)	
IS	Liquid-gas pipe sensor	STANDARD		2 x 1 mm ² (shielded) (1 circuit units) 2 x (2 x 1 mm ²) (shielded) (2 circuits units)	
MS	Duct sensor for thermostatic and enthalpic free-cooling		OPTION		2 x 1 mm ² (shielded)
RS HR/T	Duct remote sensor for enthalpic free-cooling		OPTION		5 x 1 mm ² (shielded)
CO2	CO2 Air quality probe. (Available only with enthalpic free-cooling).		OPTION		4 x 1 mm ² (shielded)
DPT	Air differential pressure transducer		OPTION		3x 1 mm ² (shielded)
AS HRT	Remote ambient sensor for enthalpic free-cooling		OPTION		5 x 1 mm ² (shielded)
DIFS	Dirty filter sensor	OPTION		2 x 1,5 mm ²	
LDRP	Long distance connection	OPTION	OPTION	3 x 1,5 mm ² (1 circuit units) 2 x (3 x 1,5 mm ²) (2 circuits units)	
DADS	Smoke detector	OPTION	OPTION	7 x 1,5 mm ²	
BAC	Hot water coil	OPTION	OPTION	5 x 1,5 mm ²	
AIRS	Airsock control	OPTION	OPTION	---	4 x 1,5 mm ²

VOLTAGE OPERATING LIMITS: 342-462V

2.- INSTALLATION

2.7.- OPTIONS INSTALLATION

ELECTRICAL HEATER

The electrical heater must be supplied from the unit's electrical box.

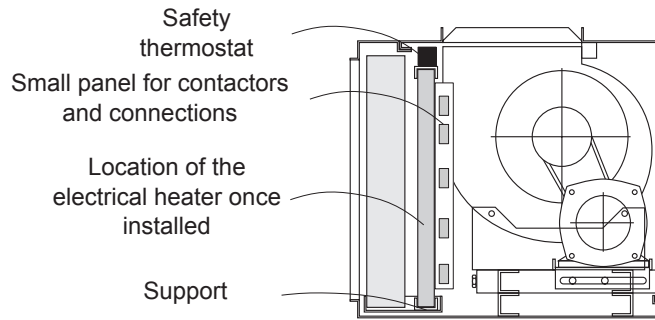

HOT WATER COIL

PROTECTION AGAINST FREEZING:

- Use glycol water. GLYCOL IS THE ONLY EFFECTIVE PROTECTION AGAINST FREEZING.

This kit includes a safety thermostat with a probe located inside the hot water coil. When the temperature drops below 4°C, the unit will stop in order to protect the hot water coil and to prevent the unit from working with very low evaporating temperatures.

Five wires must be added between indoor and outdoor unit with this option.

Hot water coil includes regulating valve:

- ON/OFF for standard and multi split.
- Proportional (0-10V), for C50 version.

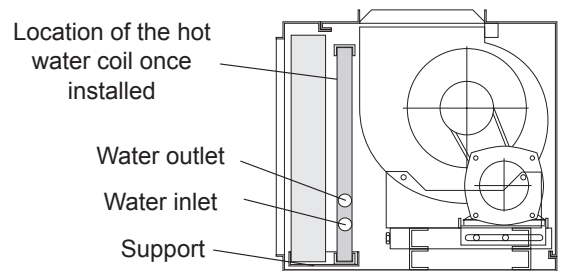

You must ensure that manual or automatic air vents have been installed on all high points in the system. In order to drain the system, check that drain valves have been installed at all low points of the system.



A HEATING COIL FROZEN DUE TO LOW AMBIENT CONDITIONS IS NOT COVERED BY THE WARRANTY.

FREE COOLING

1.- OPERATION

The control compares the values of temperature/enthalpy between outside air and room air by means of the probes; if there is a negative difference and the safety elements allow (discharge temperature probes) then the control acts on the servomotor, which opens the outside damper and closes the return damper, allowing cool outside air to enter the room.

The damper is proportionally regulated.

If there is not a great demand for air indoors, it may be enough just to have free cooling to condition the room. If there is a greater demand for air, the free cooling and the unit may need to be working in different cooling mode stages.

2.- SUPPLY AND INSTALLATION

The free cooling option can be delivered as a packaged system or as a split system.

The mixing section will be delivered with the unit for models 020S to 045D and as a split system for the remaining models.

Return fan section will be delivered with the unit.

Configuration of free cooling supply:

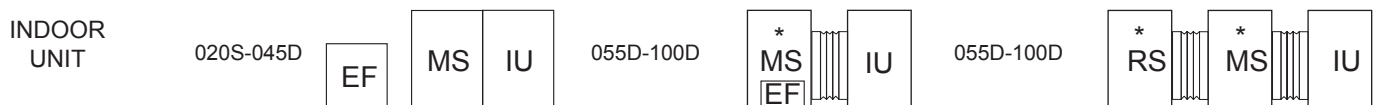

EF: Exhaust fan.

MS: Mixing section.

RS: Return fan section.

IU: Indoor unit.

Flexible duct to be installed by the customer.

* Mixing and return fan sections can be together or not.

2.- INSTALLATION

FREE-COOLING

THERMOSTATIC FREE COOLING WITHOUT RETURN FAN CIC/CIH 020S TO 045D

STANDARD VERSION

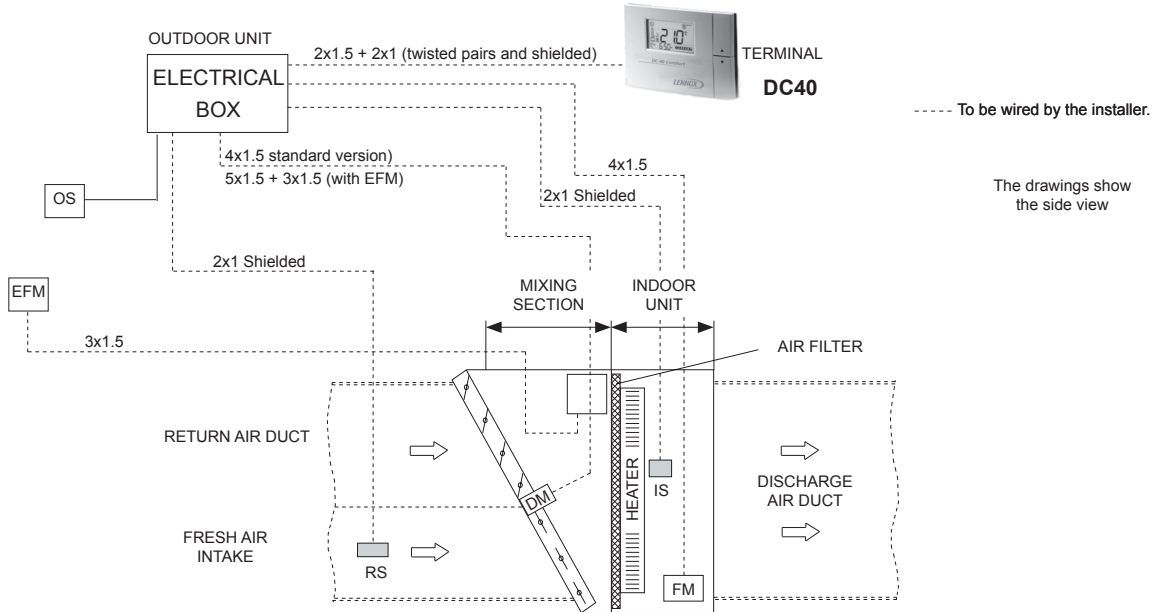

THERMOSTATIC FREE COOLING WITHOUT RETURN FAN CIC/CIH 055D TO 100D

STANDARD VERSION

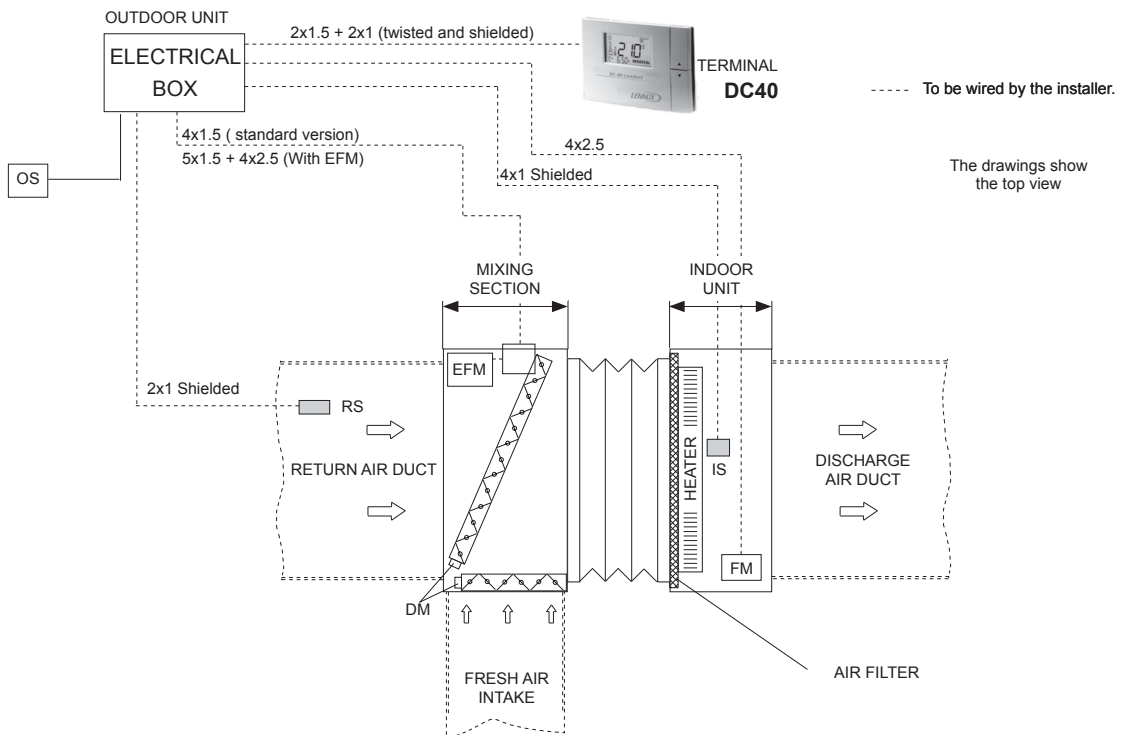

OS: Outdoor temperature sensor.
EMF: Exhaust fan motor.

IS: Liquid-gas pipe sensor.
FM: Indoor fan motor.

DM: Damper actuator.
RS: Return sensor (option).

2.- INSTALLATION

FREE-COOLING

THERMOSTATIC FREE COOLING WITH RETURN FAN CIC/CIH 055D TO 100D.

STANDARD VERSION

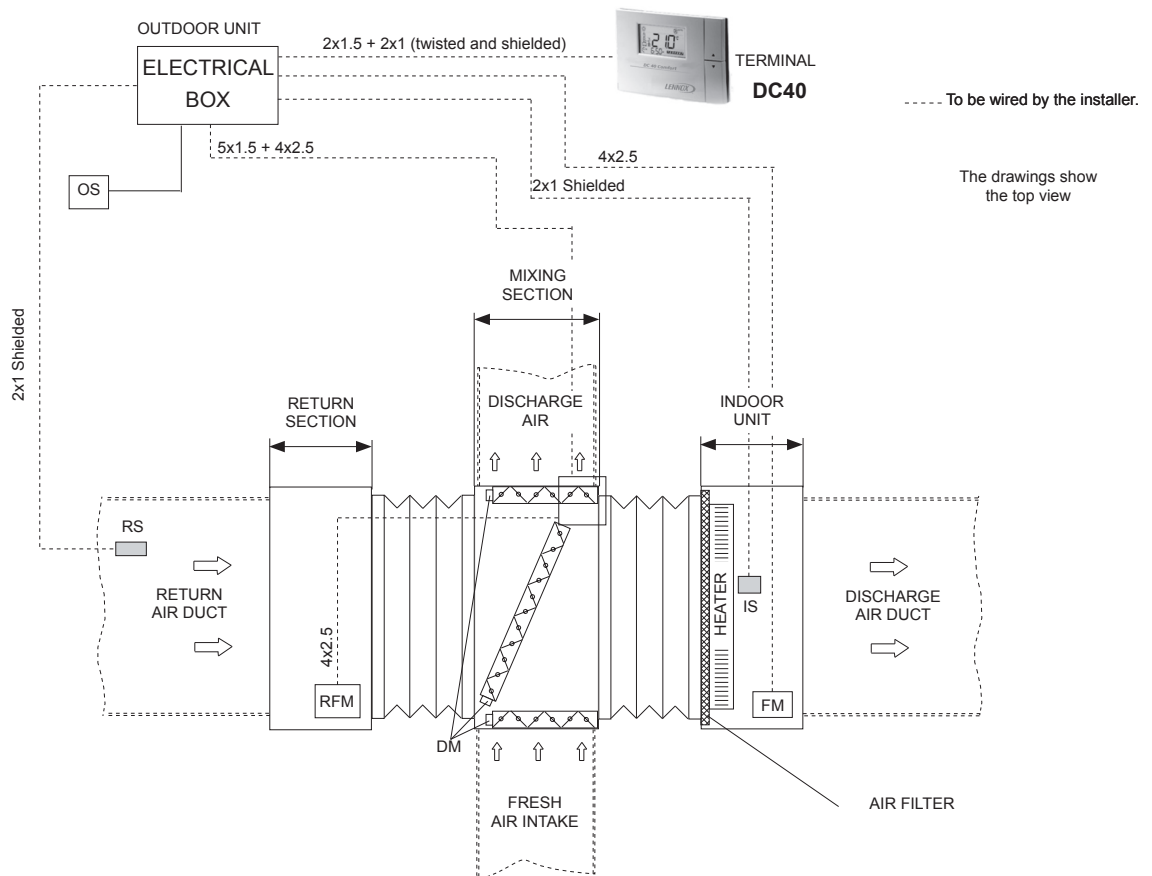

OS: Outdoor temperature sensor.
RFM: Return fan motor.

DM: Damper actuator.
IS: Liquid-gas pipe sensor.

FM: Indoor fan motor.
RS: Return sensor (option).

2.- INSTALLATION

FREE-COOLING

THERMOSTATIC AND ENTHALPIC FREE-COOLING WITHOUT RETURN FAN CIC/CIH 020S TO 045D

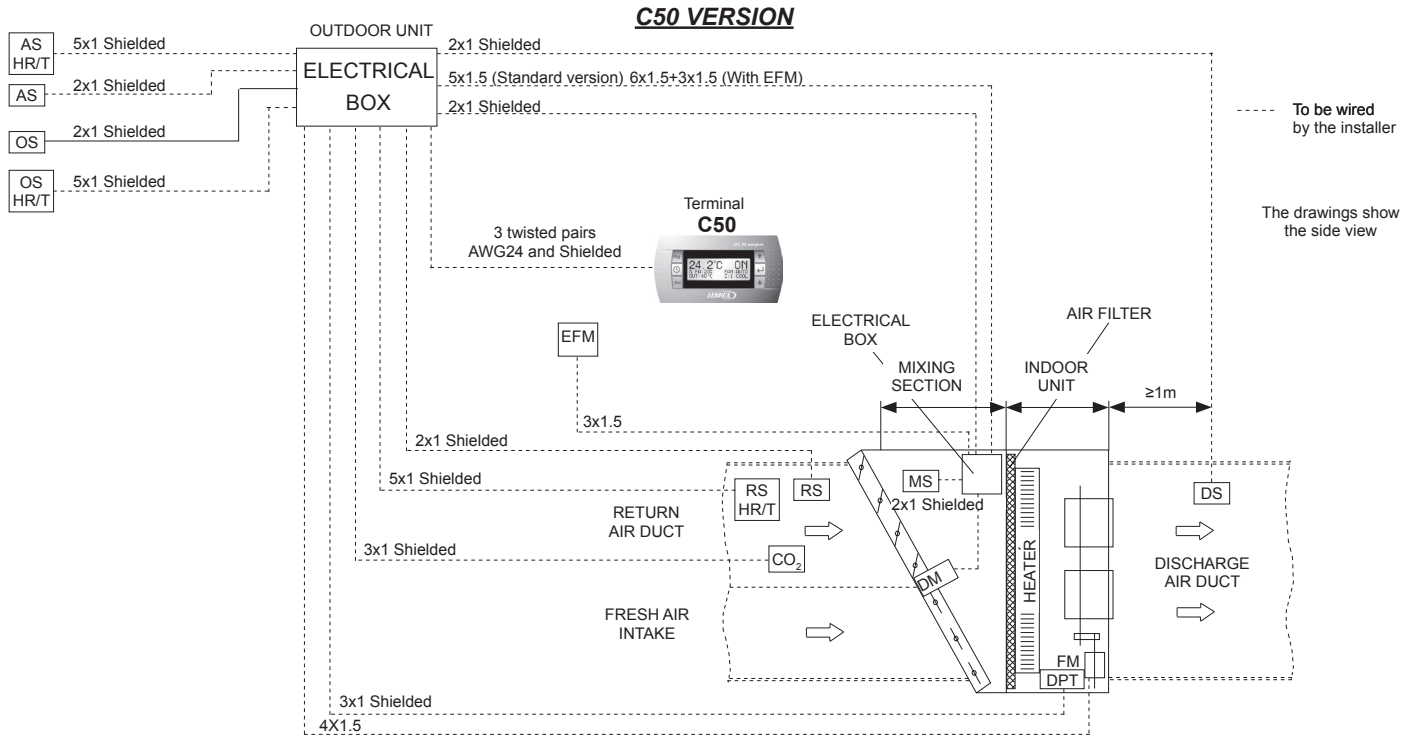

THERMOSTATIC AND ENTHALPIC FREE-COOLING WITHOUT RETURN FAN CIC/CIH 055D TO 100D.

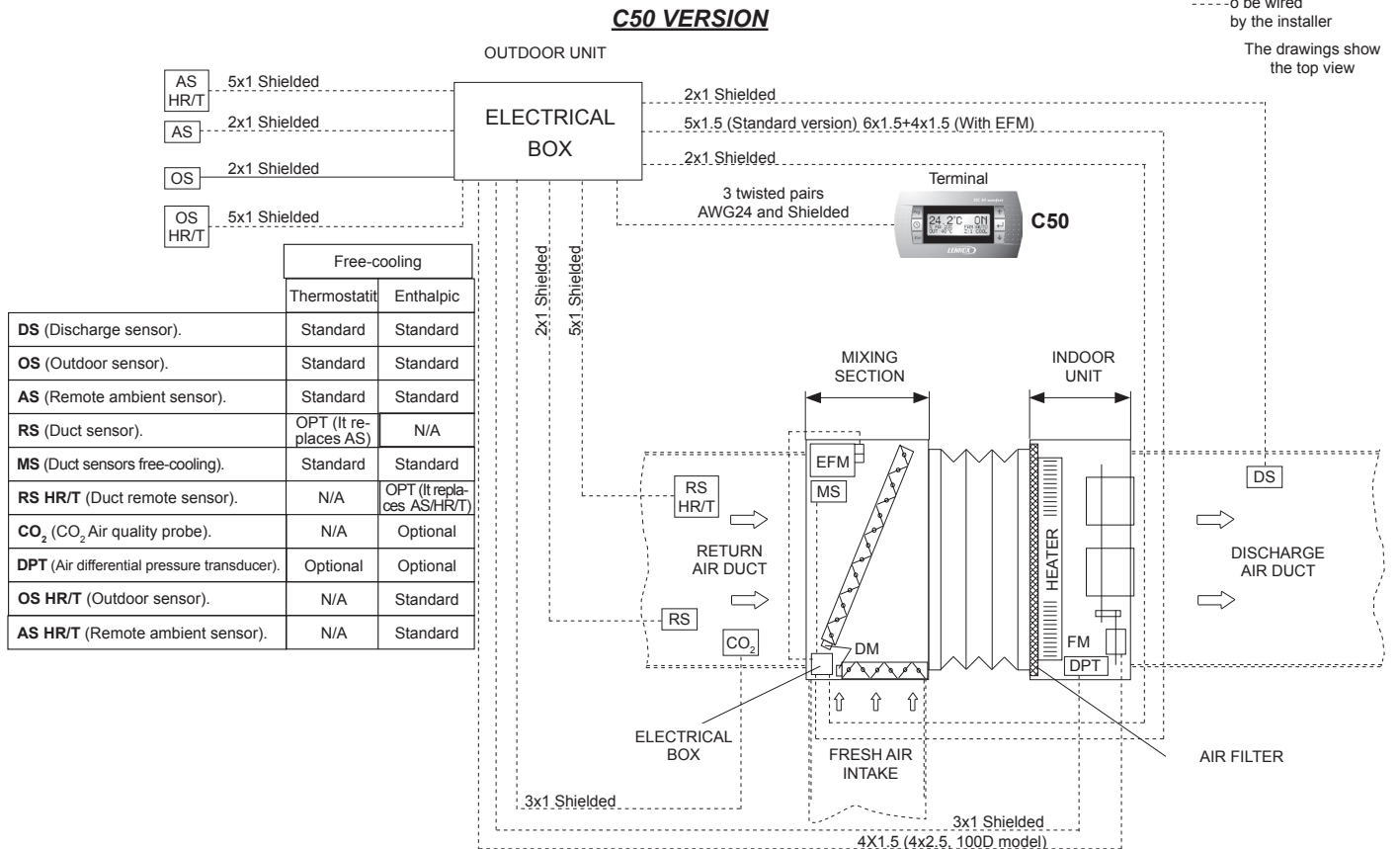

DM: Damper actuator.

EFM: Exhaust fan motor.

FM: Indoor fan motor.

2.- INSTALLATION

FREE-COOLING

THERMOSTATIC AND ENTHALPIC FREE-COOLING WITH RETURN FAN CIC/CIH 055D TO 100D.

C50 VERSION

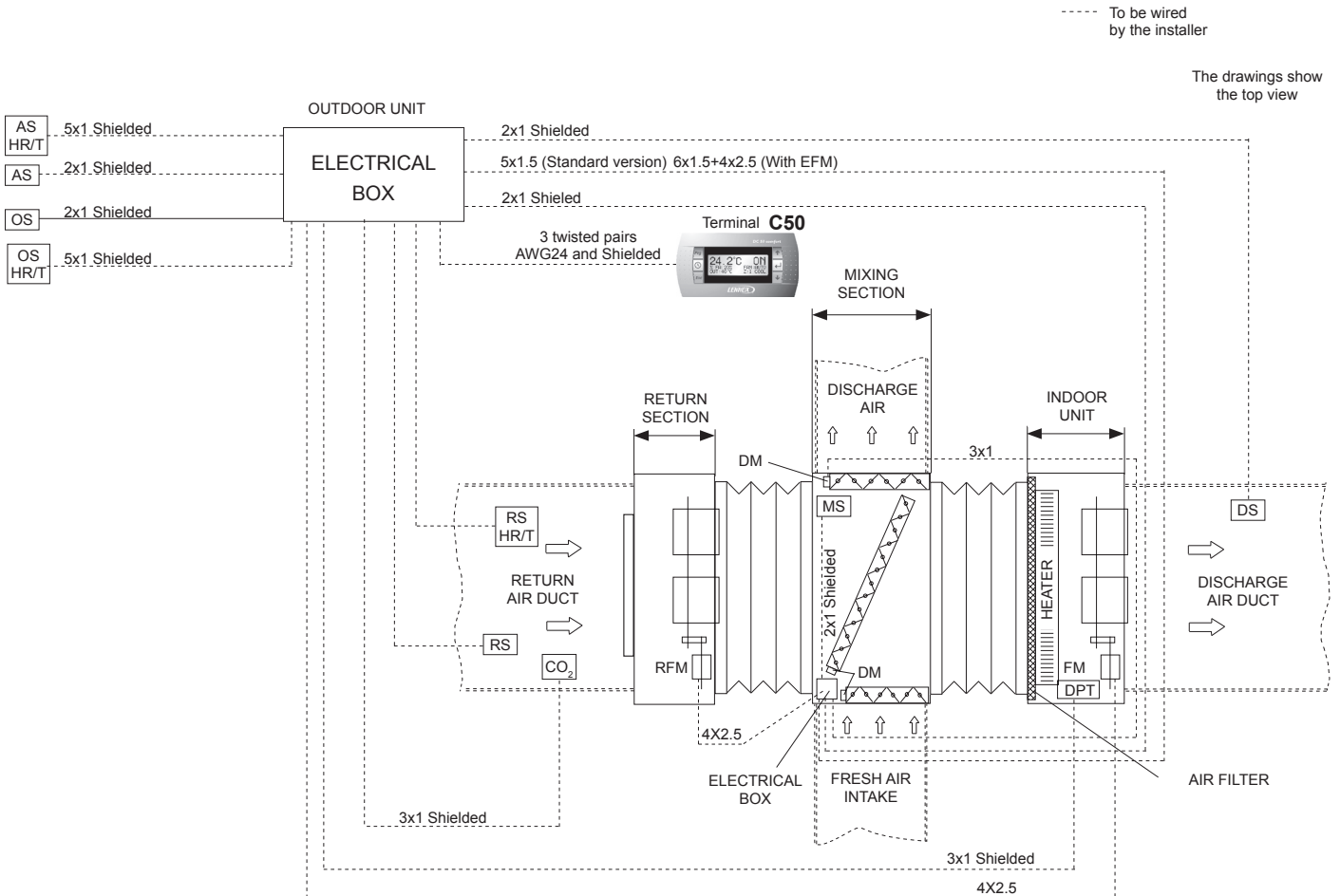

DM: Damper actuator.

RFM: Return fan motor.

FM: Indoor fan motor.

2.- INSTALLATION

FREE-COOLING

FREE-COOLING WITHOUT RETURN FAN

MODELS 020S to 045D

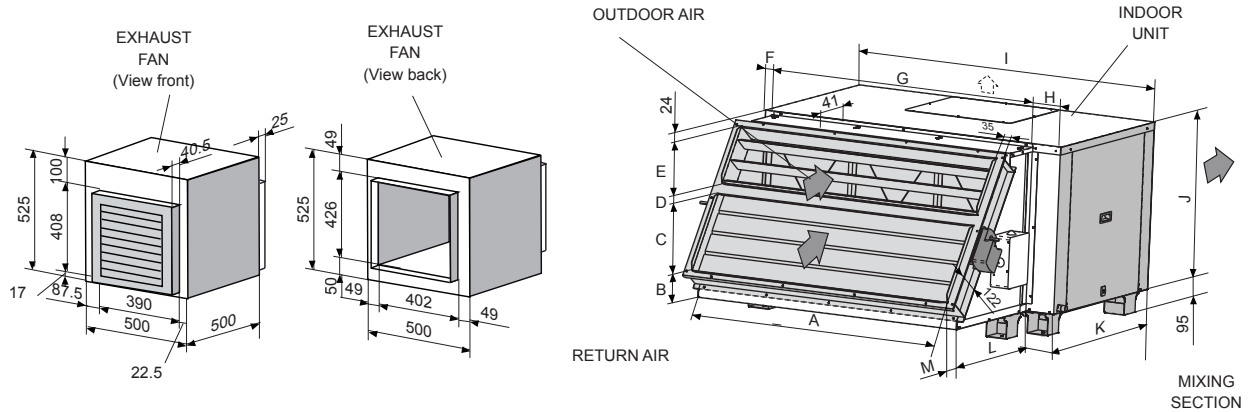

The position of the damper may be different from the one shown in the picture. See drawings.

MODELS	A	B	C	D	E	F	G	H	I	J	K	L	M
020S to 030S	1000	148,5	291	38,5	138	80,5	1013	100,5	1195	645	750	640,5	72,25
035S to 045D	1250	129,3	311,3	41	229,4	41	1268	136	1445	740	870	643,5	85,1

MODELS 055D-070D-085D

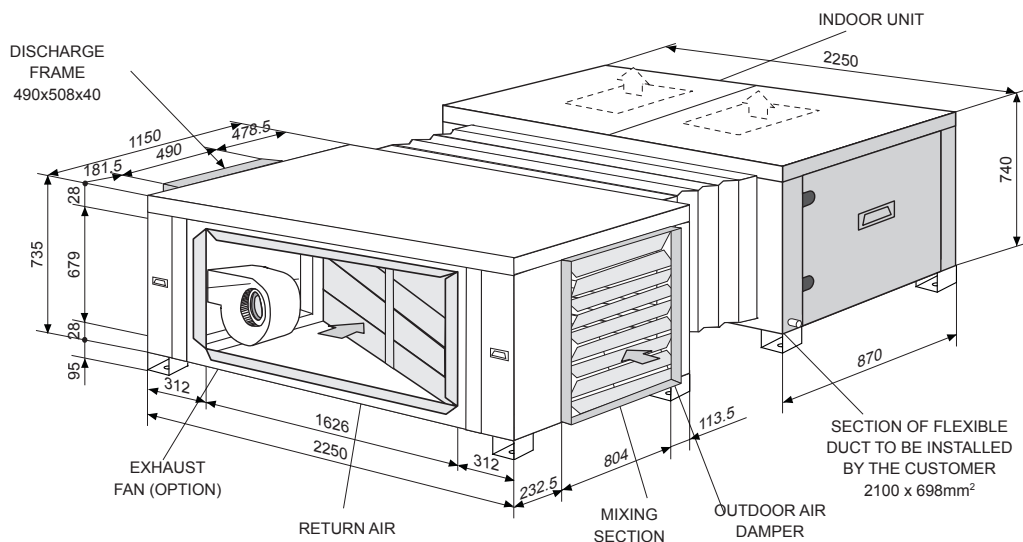

An exhaust fan may be included with free cooling without return fan.

2.- INSTALLATION

FREE-COOLING

DIMENSIONS FREE-COOLING WITHOUT RETURN FAN

MODEL 100D

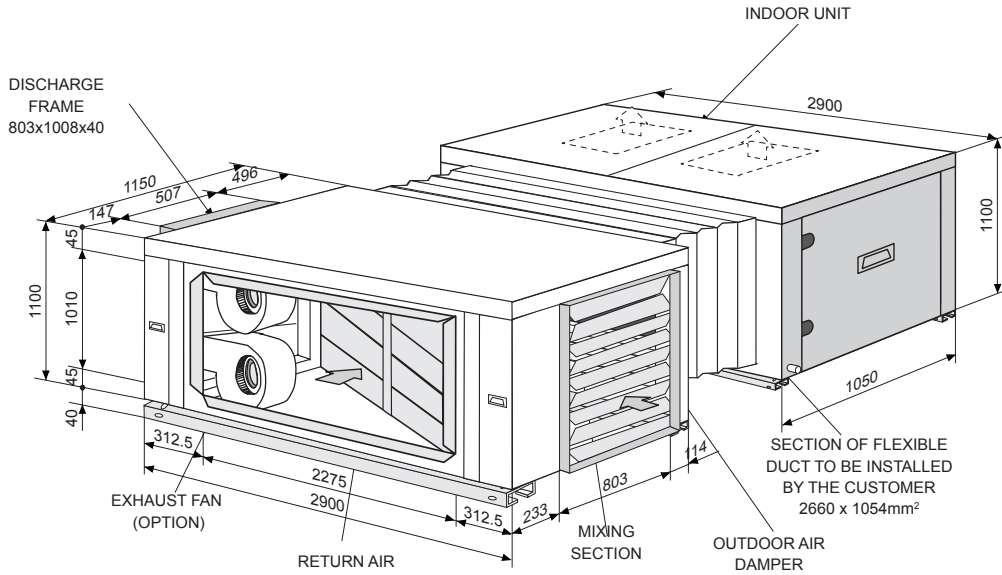

DIMENSIONS FREE-COOLING WITH RETURN FAN

MODELS 055D-070D-085D

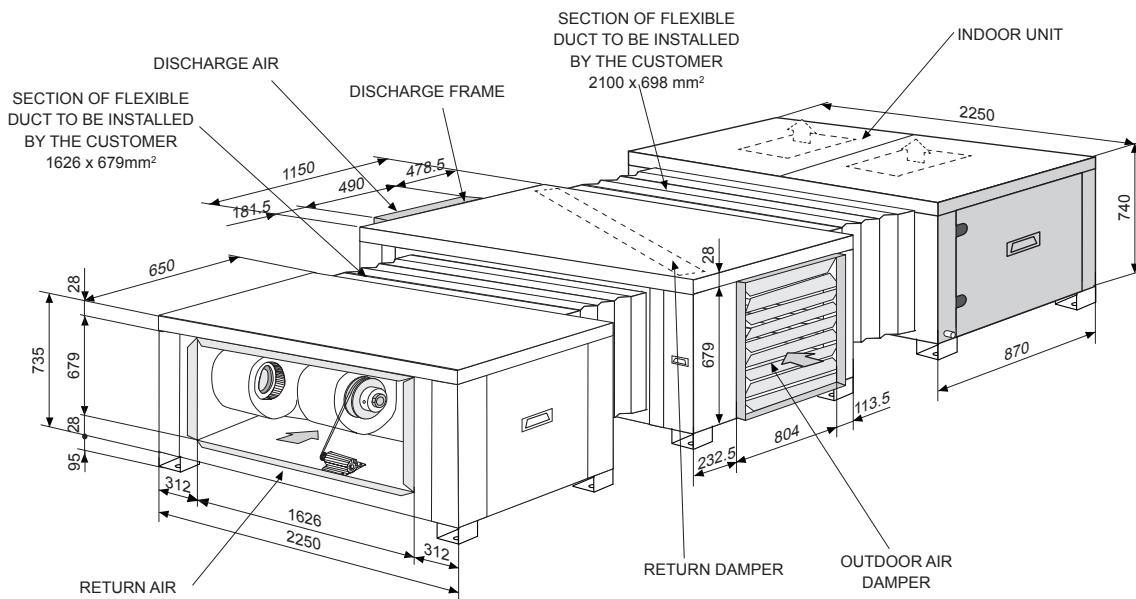

2.- INSTALLATION

FREE-COOLING

DIMENSIONS FREE-COOLING WITH RETURN FAN

MODEL 100D

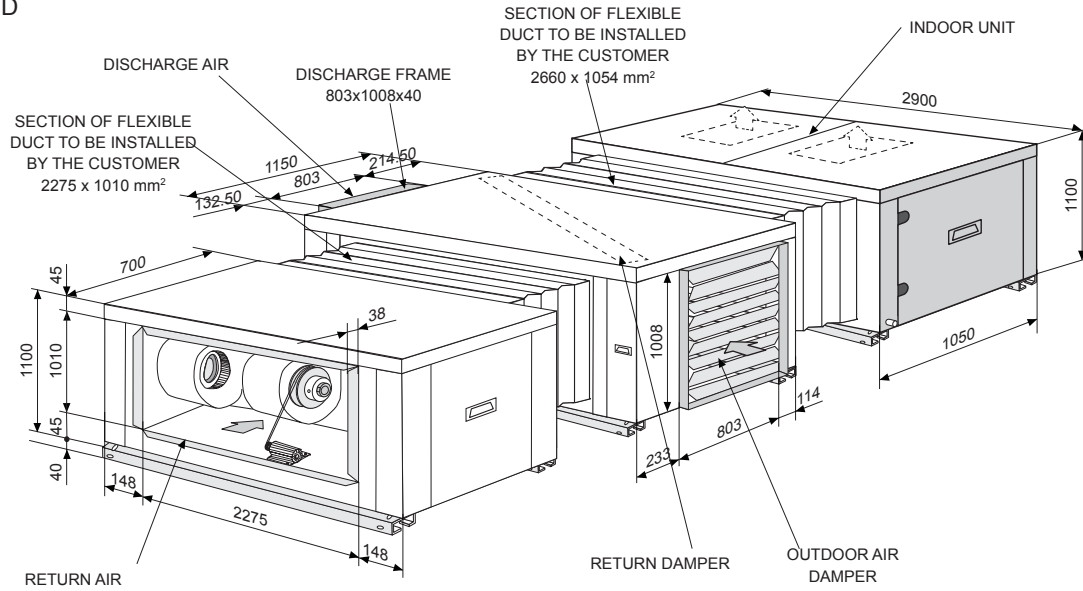

3.- COMMISSIONING AND OPERATION

3.1.- PRELIMINARY CHECKS BEFORE FIRST OPERATION

- ① Check that drainage connections and their fixtures are secure and that the **level of the unit is tipped toward the drain**.
- ② **Inspect the condition of the ducts and grilles** (grilles are clean and clear of obstructions, no breaks in the duct, etc.).
- ③ **Check that the power supply is the same as stated on the Rating Plate** and is in accordance with the electrical diagram for the unit and that cable sizes are correct.
- ④ **Check that the electrical connections are tightened onto their terminals and to earth.**
Inspect the Air Filter, which should be in its housing and correctly positioned (the metal grille should be facing inwards).
- ⑤ **Check with your hand that the fan turns freely.**

SKETCH FOR THE STANDARD UNIT CONFIGURATION IN DOUBLE CIRCUIT UNITS LOCATION

The unit can be installed outside (if an outdoor kit installation has been ordered). If this is installed, air entry and exit ducts should be fitted. The indoor unit should be assembled on bases that have been prepared beforehand. It should stand on absorbent and anti-vibration material to avoid vibrations being transmitted to the structure of the building.

DISCHARGE IN THE UNIT MODELS 045D TO 100D

Always to be done through a common duct or plenum.

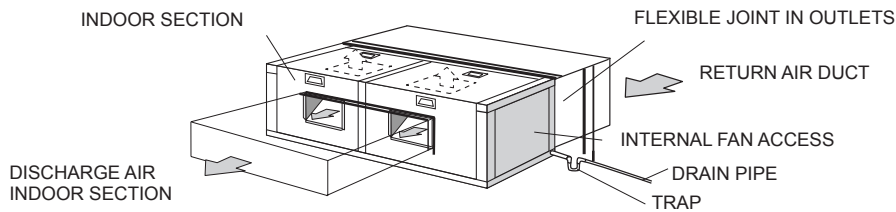

4.- MAINTENANCE

4.1.- PREVENTIVE MAINTENANCE



PREVENTIVE MAINTENANCE HELPS TO AVOID COSTLY REPAIRS, SO PERIODIC INSPECTIONS ARE REQUIRED:

GENERAL CONDITION OF THE HOUSING:

Fittings, paintwork, damage from knocks, rust spots, levelling and supporting, condition of the shock absorbers, if installed, bolted on panels, etc.

- ELECTRICAL CONNECTIONS:

Condition of hoses, tightness of screws, earthing, current draw of the compressor and fans and checking that the unit is receiving the correct voltage.

- COOLING CIRCUIT:

Check that pressure values are correct and that there are no leaks. Check that there is no damage to the pipe insulation, that the state of the batteries is correct and that there are no material clogging the duct and obstructing the air flow, etc.

- DRAINS:

Check that water drains correctly and that the drain trays are clean.

- FAN:

Check that fans turn freely and in the correct direction without excessive noises.

- AIR FILTER :

The air filter can be removed through the side by sliding it over the rail or downwards.
(See figure).

For downwards removal, remove the two profiles that support it (depending on the model) which are under the filter guide rail and screwed onto the unit.

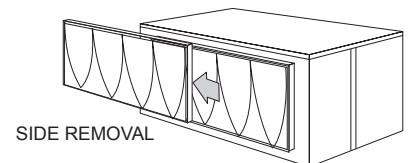

The filter should be cleaned with a vacuum cleaner or washed in soapy water.

The frequency for cleaning or changing the air filters will depend on the quality air in the area (fumes, vapors, suspended dust particles, etc.).

Remember that the metal grille should always be toward the inside of the unit.



Remember that the Control Panel may program a notification parameter, for cleaning or replacement of air filters depending on the number of hours of fan operation in the indoor section.

4.- MAINTENANCE

4.2.- FAULT DIAGNOSIS

DIRTY FILTER INDICATION

If the filters are dirty, the detector activates an alarm, but only if the fan is ON.

SMOKE DETECTOR

In this case it would initiate shutdown sequence the unit, fully close the return air damper and open the fresh air damper up to 100% and send an alarm signal to the unit.



www.lennox europe.com

BELGIUM, LUXEMBOURG
www.lennoxbelgium.com

CZECH REPUBLIC
www.lennox.cz

FRANCE
www.lennoxfrance.com

GERMANY
www.lennoxdeutschland.com

GREAT BRITAIN
www.lennoxuk.com

NETHERLANDS
www.lennoxnederland.com

POLAND
www.lennoxpolska.com

PORTUGAL
www.lennoxportugal.com

RUSSIA
www.lennoxrussia.com

SLOVAKIA
www.lennoxdistribution.com

SPAIN
www.lennoxspain.com

UKRAINE
www.lennoxrussia.com

OTHER COUNTRIES
www.lennoxdistribution.com

Due to Lennox's ongoing commitment to quality, the Specifications, Ratings and Dimensions are subject to change without notice and without incurring liability.

Improper installation, adjustment, alteration, service or maintenance can cause property damage or personal injury.

Installation and service must be performed by a qualified installer and servicing agency.



MIL105E-0909 12-2009
Original manual translation