

Application guide

COMPACTAIR

- Providing indoor climate comfort



COMPACTAIR™

APPLICATION GUIDE

Ref : COMPACTAIR-AGU-1109-E

CONTENTS	PAGE
General description - EUROVENT conditions	2
General description	3
Features and benefits	4
Options list	8
General data	12
Performances - Selection procedure	14
Ventilation data	15
Peformances	20
Auxiliary heaters selection	33
Acoustic data	34
Refrigerant connections	37
Electrical data	38
Options electrical data	39
Electrical connections	40
Dimensional data	44
Weight data	50
Airflow configurations	51

Our products comply with the European standards,



Product designed and manufactured under a quality management system certified ISO 9001.



All the technical and technological information contained in this manual, including any drawing and technical descriptions provided by us, remain the property of Lennox and must not be utilised (except in operation of this product), reproduced, issued to or made available to third parties without the prior written agreement of Lennox.



All data are at Eurovent conditions.
<http://www.eurovent-certification.com/>

PROGRAMS : AC2/A/P/C
AC2/A/P/R
AC3/A/P/C
AC3/A/P/R

COMPACTAIR™		20S	25S	30S	35S	40S	45D	55D	70D	85D
Cooling mode										
Net cooling capacity	kW	19,25	24	27	35	40.5	46	56	69.5	83
Power input	kW	7,26	9,23	11,0	13,7	15,9	18,8	21,5	27,8	32.6
Net EER		2,65	2,6	2,45	2,55	2,55	2,45	2,6	2,5	2,55
Heating mode										
Net heating capacity	kW	19,25	25	29.5	36	42	49.5	59	69,5	81
Power input	kW	6.64	8.62	10.7	12.4	14	17.4	20.3	24,8	28.4
Net COP		2,9	2,9	2,75	2,9	3	2,85	2,9	2,8	2,85
Acoustic										
Outdoor noise power level in duct	dB(A)	80	83	86	84	84	88	87	88	89
Indoor noise power level in duct	dB(A)	72	78	80	80	83	86	80	85	87

AC2 Program = 12 < 45 kW
 AC3 Program = 45 to 100 kW.

UNIT CONFIGURATIONS

COMPACTAIR™		20S	25S	30S	35S	40S	45D	55D	70D	85D	100D
Monobloc	CMC / CMH										
Split	CSC/CSH - CIC/CIH										
Dual Split	CDC / CDH - 2x CIC/CIH							2x30S	2x35S	2x40S	

MODEL NUMBER DESCRIPTION

C	C =	COMPACTAIR™
	-	1st letter
M	W =	Water cooled
	I =	Indoor
	M =	Monobloc/Packaged
	S =	Split
	D =	Dual split
C	C =	Cooling
	H =	Heat pump
024	Cooling capacity	
S	S =	1 circuit
	D =	2 circuits
N	N =	No heat
	S =	Standard electrical heater
	H =	High electrical heater
	M =	Medium electrical heater
	V =	Hot water coil standard heat
M	A =	R22
	K =	R407C
	M =	R410A
	P =	R134A
	Z =	No refrigerant
1	Revision number	
M	T =	230V/1/50
	M =	400V/3/50

**CMC
CMH**



**CIC
CIH**



**CSC
CSH**



2 CIC / CIH



**CDC
CDH**



APPLICATION

Introduction

COMPACTAIR™ is an AIR to AIR packaged air conditioner unit for indoor installation, sheltered from bad weather conditions. Its particular “cupboard” design is made for comfort cooling & heating of medium to large volume premises (200 to 1000m² per unit) in urban environments, where installation on the roof is too complex.

COMPACTAIR™ is designed to be installed indoor with duct connections:

- from the condensing section to the Outdoor
- from the treatment section to the premises to be air conditioned.

The COMPACTAIR™ range has been designed to be flexible for our customers, it can either be a simple unit when first cost is the main driver, but many options can be added to make the COMPACTAIR™ a premium product.

Adaptable product:

- 20 to 100 kW cooling and heating capacity available in 4 different boxes
- Cooling only or reversible heat pump unit, that can be completed by auxiliary heating capabilities
- Variable supply airflow from 3150m³/h to 22450 m³/h and up to 600 Pa (External Static Pressure)
- Variable external static pressure up to 350 Pa at the condenser section to adapt to wide possibilities of ductwork (see tables nr 3.16 to 3.26)
- Many versions and airflow configurations to adapt to site configuration and optimize ductwork
- Monobloc, Split and Dual Split configurations for high adaptability to site construction
- Up to 65 m. distance between air treatment section and compressor section on split & dual split versions.

Preserving architecture

COMPACTAIR™ is a ductable unit made for indoor installation: the only elements appearing outdoor are protection grills beyond duct connections. In many city centres, historical protection requires the preservation of building architecture. Having no HVAC machinery elements on the external building fronts protects the original architecture.

Grills are flexible elements that can be highly integrated in the environment.

Commercial footprint requirement minimized

Estate surface in urban areas can be rare and expensive. The compact vertical design of COMPACTAIR™ minimises the occupied footprint, to preserves the available surface for commercial activity. For the COMPACTAIR™ to be the market leader in efficiency on footprint it uses bended coils.

Easy installation

The vertical design of the COMPACTAIR™ ensures it fits through most door openings and standard urban room height. The maximum height of the monobloc version is limited between 2,05 m and 2,15 m: the availability of the monobloc version is between 20 to 87 kW facilitating the installation, limiting the handling and ductwork. Many airflow configurations are available to adapt to most premises characteristics.

Economizer (size 020 to 045) and filter frames are optional elements delivered fixed to the base unit to ease handling and installation.

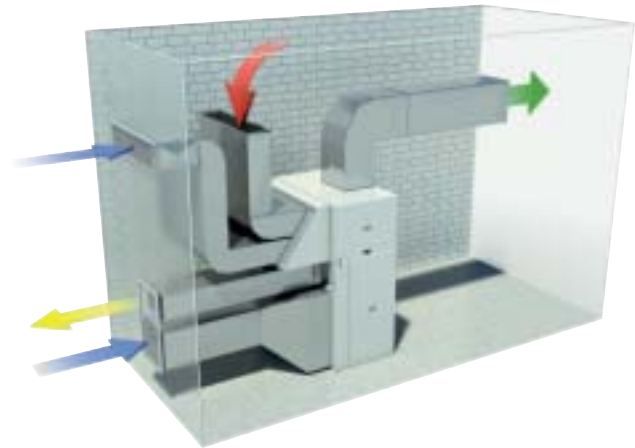

ENERGY SAVINGS

Economizer :

In many retail and light commercial applications, internal heat loads (lights, customers, white goods...) have to be covered 12 months a year, even in winter. The economizer module uses the external air input for cooling operations as soon as the outdoor temperature is lower than the set point.

In that case, the compressors stop, reducing the cooling system consumption to the treatment ventilation.

Dynamic defrost (under patent)

Airconditioning units generally start defrosting when the outside temperature is below a given value. The cycle repeats periodically.

This results sometimes in starting an expensive defrost cycle when it is very cold outside but very dry: in other words, when the coil is not frozen.

After many tests in the Lennox laboratory, it was found that it is possible to know exactly when the coil is frozen, by analysing the temperature difference between the coil and the outside temperature.

With this built-in feature of the CLIMATIC™ 50 and Climatic™ 40, Lennox ensures to start a defrost only when necessary, hence saving energy and improving comfort.

Gained values at 0°C, 90% humidity:

-On Energy efficiency:

The defrost cycles starts only when required: divided by 3 to 4 the number of cycles.

At the conditions mentioned, dynamic defrost saves up to 2h15 minutes of cooling cycles over 1day.

Those 2h15 minutes equals energy savings per day: 9% of energy saving.

-On Comfort:

In defrost cycles the airconditioning units operations are reversed. It means that instead of supplying heat in winter, it supplies cold.

Speaking comfort, dynamic defrost avoids up to 2h15 minutes of cold air supply per day.

R410a refrigerant & Copeland Scroll Compressors

The COMPACTAIR™ refrigerant circuit is running with R410A refrigerant gas. This means high efficiency compared to most of the similar units on the market. R410A technology is combined with scroll compressors on the whole range to offer the best efficiency. This combination makes the COMPACTAIR™ the best average efficiency in cooling and heating mode on the market (EER & COP at Eurovent conditions).

Timezone management

As a standard feature, CLIMATIC™40 & CLIMATIC™50 provide time zone scheduling: respectively 2 and 4 scheduling time zones per day on 2 periods per week (week / weekend) or 7 days. This allows energy consumption management according to the building use. On each of the time zones, heating set point, cooling set point, minimum fresh air (with C50), humidity set point high and up (with C50), and even the different authorisations for cooling and heating can be adjusted (with C50).

Dynamic Set Point

Throughout the year, the cooling requirement is not the same. Also the comfort requirement in a building depends on the outdoor temperature. Entering a 22°C room when outdoor temperature is 35°C can create a feeling of cold instead of comfort. The dynamic set point function adapts the temperature set point throughout the year, increasing in hot days, approaching initial set temperature in more “average” days. This also creates energy savings, helping the Compactair™ to reach the right temperature quicker

COMFORT & AIR QUALITY

Fresh air management

Fresh air is an important point for comfort. In many countries, local building regulations make fresh air mandatory in commercial premises in different ways.

The COMPACTAIR™ equipped with the “Economizer” enables a minimal permanent fresh air inlet.

Air quality management

Fresh air is prior to supply the best ambient comfort. On the other hand, a fresh air input is an expensive operation at high and low temperature. Lennox supplies an intelligent management of fresh air to adapt the accurate.

The fresh air level can be adapted at the commissioning for

permanent inlet. It can also be adapted to instant “Consumption” with an Air Quality sensor, in order to maximize efficiency and fresh air level.

G4 filtration

Two filtration levels are available. The standard equipment is G4 washable and refillable filters with metallic frame 50 mm. This configuration allows extending the lifecycle of filters and reducing the cost of replacement, changing only the media. 50 mm filters have been selected also to reduce the energy consumption due to lower pressure drop especially when the filters start being dirty.

Low operating noise

COMPACTAIR™ offers the best low noise performance of the vertical packaged HVAC market, considering supplied noise in diffusion duct, exhausted noise to the external environment & radiated noise around the unit are all performing at the highest of market standard. While designing the COMPACTAIR™ unit for indoor installation and urban areas, the noise power level was considered critical by Lennox. Therefore, Lennox offers the possibility to reduce the operating noise for most of the standard conditions, with the inverter low noise control option. This feature limits the noise at the minimal level on demand.

OUTDOOR NOISE POWER LEVEL

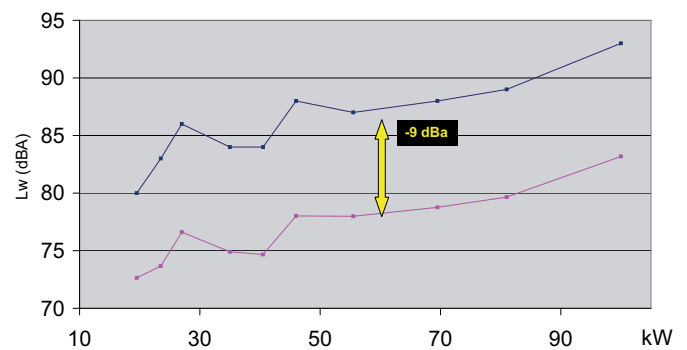

RADIATED NOISE POWER LEVEL

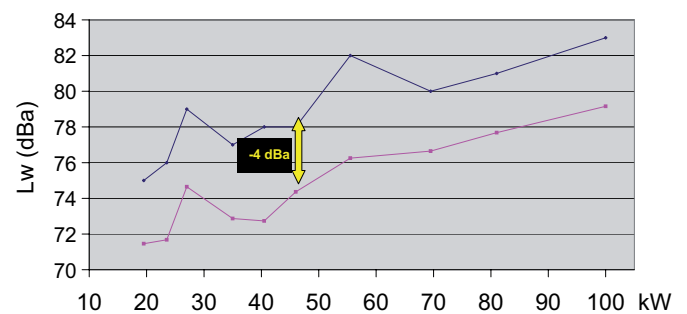

CONTROL

COMPACTAIR™ can be equipped with 2 control platforms corresponding to different functionality levels.

Most of the standard uses are addressed by the CLIMATIC™ 40 platform with exclusive Lennox Air-To-Air software. This electronic platform is supplied with most of the stand alone unit control and dual split units.

For advanced functionality, COMPACTAIR™ is equipped with Climatic™50 microprocessor based capability which benefits of Lennox Rooftop software. The CLIMATIC™50 is developed by the Lennox R&D for all Air-to-Air units, Rooftop & Packaged units.

Climatic™40



This electronic control has been developed in partnership with Carel. It integrates the exclusive Lennox functions such as dynamic defrost, dynamic set point and outdoor fan speed control at low ambient temperature or for low noise time

periods.

This software has been designed to improve the efficiency and performance management compared to the previous platform Climatic™10. It particularly increases the flexibility of the COMPACTAIR™ adaptable to many applications whilst the environment remains competitive in first cost.

The Climatic™40 platform is supplied with a Comfort user display DC40 as standard, delivered if no external communication devices are selected.

Climatic™40 acts for lasting performance and improved service operations: 30 default alarms are available.

CLIMATIC™ 50

The CLIMATIC™ 50 inherits 15 years of technology and field operating experience from its predecessors the CLIMATIC™1 and CLIMATIC™ 2. LENNOX has developed the software specifically designed for rooftop applications and adapted to other LENNOX Air-To-Air packaged units, maximizing efficiency and performance.



CLIMATIC™ 50 has been thought to be user-friendly and easy to understand. However it has been designed to be powerful and flexible: for example it enables the communication with a wide choice of Building Management Systems, humidity control or air quality level or establish the Master-Slaves strategy between several units.

Enhanced with a 16 bit processor at 14Mhz and a 2 Megabytes flash memory, CLIMATIC™ 50 has been designed to save energy and to extend the operational life of the COMPACTAIR™ product range. It will, for example, optimise the running time of each compressor, automatically switch between compressors from those that start first and have an anti short-cycle program. It is able to control 34 fault signals and manage security algorithms generating various fault signals. In terms of comfort, CLIMATIC™ 50 provides an innovative PI control.

CLIMATIC™ 50 looks at difference between set point and room temperature and calculate the time needed to each the set point and determines the capacity required. This innovative control will guarantee a better temperature accuracy, while saving energy by not bringing the full capacity when not needed.

Since cooling is often not the only requirement, hot water coils or electric heaters can be provided with proportional control. Heat pump with multi step regulation is also available.

Step of heating priority

A unique feature on the market, CLIMATIC™ 50 allows the user to decide which heating element will come first. This works perfectly on units using auxiliary heaters, it is possible to prioritize heat pump mode down to an adjustable set point (for example 0°C) and switch to hot water heating mode below this value. This gives the benefit of the excellent heat pump COP when outside temperature is not too cold and allows using hot water heated by gas boiler or solar panels when temperature is appropriate.

Flexibility

CLIMATIC™ offers incredible flexibility. For example, advanced users can go in the heart of the regulation in deciding reactivity of the PI algorithm or by setting supply temperature limits. They might even decide to authorize or not some heating or cooling device depending of the outside temperature.

Automatic summer/winter time change

CLIMATIC™ 50 offers an automatic time switch from winter to summer. This had always been a problem in the past for some customers to have kept their unit at the right time, jeopardising all their effort to optimize energy consumption by smart scheduling.

Noise reduction feature

During unoccupied timezone, COMPACTAIR™ will work on half of its capacity by using only half of the compressors and half of the condensing fans (for double circuits units). Therefore it may cycle more often but is quieter when running. This option is very often used at night when the capacity needed is lower and when low noise matters more.

Last 32 faults stored in the mother board

Part of the new features of CLIMATIC™50 is the storage in the main mother board of the last 32 faults with time, date and fault code. This can be seen with DS50 Service Display or Adalink, even if they were not connected when the fault occurred.

Staggered start feature

If there is a power shortage, units will not restart at the same time. To make this feature available, units have to be addressed with a different number between 1 and 12. The unit will start a number of minutes after power return depending on its address (Address * 10 seconds). Example : unit number 3 will start 30 seconds after power is back. This is a very important feature to avoid peaks of current.

EASE OF INSTALLATION & SERVICE

Circuit breakers

To improve the safety of the COMPACTAIR™ and extend its life, circuit breakers protect against over-loading, over intensity and a disconnected supply phase. Maintenance is also improved as there is no requirement to change fuses. The electrical panel is manufactured in accordance with EN60204-1 (1998) electrical directive.

Adjustable ventilation

Airflow and External Static Pressure characteristics are adjusted in the factory to deliver the right pulley and belt to be the nearest to the site needs. However, once on site, the real characteristics of ventilation requirement might be slightly different than theory measured on drawings: therefore, COMPACTAIR™ is delivered as standard with adjustable pulley opened. This remains the possibility to adjust the airflow accurately at the commissioning and find the perfect airflow for the site comfort and system efficiency.

Easy to access

All internal components access of the COMPACTAIR™ are closed by panels equipped by locks and handle for quick and easy dismounting. No more screws are used as panel fixtures.

External access to pressure gauges

Pressure gauges are installed externally for easy pressure measurement. This common measure doesn't require access to the refrigeration section and the COMPACTAIR™ can continue to operate.

EXTENDED LIFECYCLE

Casing

Made of galvanized steel, the casing is covered with Epoxy RAL 9002 paint

Assembly quality, compliance to PED 97-23, EN 60204-1, CE, made in an ISO 9001v2000 factory.

What makes the difference are the small details which have given LENNOX its reputation. Electrical components are selected to the highest standards, refrigeration components are generously sized to ensure maximum performance and reliability. Quality manufacturing procedures together with a culture of continuous improvement at all LENNOX factories, ensures the products are built to the highest standards. COMPACTAIR™ complies to EN60204 norms, PED 97-23 directive, is CE compliant and is built in an ISO9001v2000 certified Factory.

SAFETY

Fire-insulation

Air treatment sections of COMPACTAIR™ are insulated with M1 material: this insures that the insulation doesn't burn and doesn't create toxic smoke.



FRESH AIR OPTIONS

Economizer module

"Free cooling" is provided through the use of fresh air when appropriate rather than cooling the return air. The use of an economiser is the easiest and most efficient way to modulate fresh air volumes and reduce running costs for commercial application, as well as improving air quality.

The fresh air management can be controlled in 3 accuracy degree:

- Minimal permanent opening % of fresh air damper with Climatic 40
- Minimal permanent fresh air % with Climatic 50 – which brings more accuracy and saves energy. An intelligent electronic management adapts the volume of fresh air to the % of damper opening.
- Automatic Accurate adjustment of fresh air level according to instant room requirement. It adapts to fresh air consumption which varies with the number of visitors and their physical activity. This able to improve the Comfort and saves energy. Possible with Climatic 50 and Air Quality Sensor.

2 constructions are available :

- on A & B-Box, the module is made of 2 dampers- fresh air & return air - driven by an actuator. Both fresh air and return air are ducted. The module is delivered fixed to the supply part (can be delivered separately on demand).



- on C & D-Box, the module is made of a 3 dampers –fresh air, return air & exhaust air- driven by 3 actuators. All dampers are ducted. The module is delivered loose from the Air treatment section.



Exhaust module

Combined with Economizer to eliminate the room overpressure when a large quantity of fresh air is introduced in the room. The fan starts only over a percentage of fresh air inlet.

Lennox provides 2 configurations depending the size of the Air Treatment section :

- On A Box and B Box, the exhaust fan is supplied loose for installation in return duct or in any place on the building.
- On C Box and D Box, the exhaust fan is integrated in the economizer: the overpressure is directly evacuated from the return.

Return Module

The return module is made for return duct circuit with high pressure drop. It offers up to 250-300Pa ESP.

It is made of a extra box to connect with duct work to the Economizer. The return module is available on C Box.

INDOOR AIR QUALITY

Air Quality sensor

Quantity of fresh air is one the most important factor of People Comfort with T°C. The lack of fresh air in a room can lead the visitors to headaches or bad feeling due to increased carbon monoxide degree. This affects directly the commercial activity, especially in application where people stays an important time in the premises: restaurants, bars, theatres or shopping malls. The inlet of high fresh air volumes on a permanent way can also be very expensive. Lennox has developed specific functionality to reduce the inlet volume to the strict instant requirement, based on CO₂ level : this condition a permanent comfort and reduce the extra energy consumption of fresh air to a strict minimum.

Advanced control for enthalpy and humidity

Where a higher level of controllability is required to make the COMPACTAIR™ even more flexible, LENNOX have compiled a pack that includes two advanced control features.

- "Enthalpy control on economiser". Software and its sensors will ensure that the economiser does not use 100% fresh air if the outside air has a higher enthalpy than the return air. This feature is relevant in regions where the relative humidity is high or when the desired room air condition is very dry.
- "Humidity control" software and its sensors, are able to analyze dry and wet bulb temperatures, and therefore can control a dehumidification algorithm. This will dehumidify the air in cooling mode as it passes through the coil, then reheating it with either electric heater or hot water coil. If there is a need to humidify the air, a proportional contact is available to control a humidifier that will be provided by the customer.

Dirty Filter sensor

This sensor analyses the dirt level of the filters and informs the user when it is time to change. This option is featured with Climatic 40 platform.

The functionality is extended with Climatic 50 platform: the dirty filter sensor becomes analogic and intelligent. It informs the user of the filter dirt level, possible fan or filter default: filter missing, belt broken etc...

G4/F7 filtration

G4 pre-filter / F7 filter both in metallic refillable frames - 50 mm G4 and 100 mm F7. This configuration allows extending the

lifecycle of filters and reducing the cost of replacement, changing only the media. 100 mm filters have been selected also to reduce the energy consumption due:

- to lower pressure drop especially when the filters start being dirty.
- to reducing the replacement frequency

AUXILIARY HEATERS

Additional or instead of Heat Pumps, Lennox offers many auxiliary heaters on every Air-To-Air units. This helps to adapt to local climate requirement, local regulation preferences and applications variable heating needs.

Electrical Heaters Stepped or Modulating

Standard, Medium and High heating power capacity are available on each unit size (capacity details table 4.3).

Standard heat is made of 1 heating step, while medium heat is made of 2 heating steps.

High heat capacity coil is available in 2 heating steps (1 step on size 100 – Climatic 40 control platform) or fully modulating which helps to increase the comfort feeling and reduce electrical peak consumption.

The electric heater comprises of shielded resistance heaters, which are smooth anticorrosion tubes 8 W/cm² capacity. 3 security elements are insuring permanents control of the heaters:

- 2 High temperature limit control offers overload protection. An automatic reset safety thermostat is set at 75°C – a manual reset safety thermostat is set at 105 °C; both located at less 150 mm over electric heaters. This is provided as a standard feature on the electric heater, with the electric power supply cables made of reticulated silicon rubber, resistant to temperatures up to 200°C.
- an air pressure differential is control the fan activity and disconnect the electrical heater in case of critical airflow
- dual contactor are insuring safe redundancy in case of failure of one dry contact

Hot Water Coil

Hot Water Coil offer an increased 2 comfort degree is offered with Hot Water Coil: it can be control as one step heater either as modulating heater.

1 step heater is controlled by an ON/OFF valve which requires glycol antifreeze protection.

Modulating heater is equipped by a 3 way valve offering accurate comfort & electronic adjustable antifreeze protection. This avoid the use of glycol in most of European regions.

Hot Water Coils & control valves are factory fitted in air treatment section.

REFRIGERATION OPTIONS

Winter Cooling Operations down 0°C

This option allows the Compactair to work in cooling mode with an outside temperature down to 0°C (instead of 15°C in the standard unit). This is specifically needed when free-cooling operation is not possible. This function is made of condenser fan alternate start/stop that maintain a constant condensing pressure. Heat pump version has this possibility as standard

Service Valves

Consists in liquid and gas service valves that isolate the refrigerant section during maintenance. This is particularly useful when components of the circuit have to be changed. It reduces the time and cost of maintenance operation.

Refrigerant pre-charged

The Compactair Split and Dual Split are delivered with Nitrogen in the refrigerant circuit of the Condensing section. The compressor section can be fitted with refrigerant: in that case, the condensing section would be equipped of service valves.

Long Distance refrigerant connection

In any situation where the distance between the condensing section and the treatment section is over 40 meters of copper piping, this kit has to be installed. It allows distance up to 65 meters.

INSTALLATION AND SAFETY

Air Socks control

Slow starter of supply fan motor to introduce an increasing air volume over 1 minute in air socks. Help largely to protect the air socks ducts against braking.

Made by electronic slow start, Inverter technology.

Main disconnect switch

Main disconnect switch is lockable to make a safe access to electrical panel. It is installed on the electrical panel door of the compressor section and controls all parts. Is also used as emergency cut off: it is mandatory to guarantee a proper access to this switch.

Main disconnect switch is sized accordingly to the options fitted in the unit.

Smoke detectors

Located in the indoor unit, after the filter. Fotoelectric head of the smoke detector can detect any type of smoke. In this case it would initiate shutdown sequence the unit, fully close the return air damper and open the fresh air damper up to 100% and send an alarm signal to the unit. The safety protocol requires the presence of an economizer and exhaust capabilities.

In accordance with European norm and stronger regulation like French ERP regulation.

Compressor electrical protection

Return lock against 3 phases inversion at installation. This protection prevents the Scroll compressor to start and operate in wrong sense: in the case that the electrical phases are wrong connected, the compressor will not start. Particularly required when the installation of the AC unit is made before the installation of electrical wirings.

Coil Anticorrosion protection

Lennox can provide several type of coil anticorrosion protection specifically made for salted or polluted environments.

For low polluted and salted environments, Lennox is offering Aluminium Coated Coil. This option can be selected on external coil only or external and treatment coil for high level of fresh air are required.

This standard anticorrosion is particularly recommended in urban environments.

For more aggressive environements, such a coastal environment, Lennox offers solutions on special demand for Thermoguard treatment solutions. With Thermoguard treatment, coil are guaranteed against corrosion during 3-years (provided regular maintenance is performed).

CONTROL, COMMUNICATION & SUPERVISION

Inverter Low Noise control & Winter Cooling operations down -15°C

Acts on 3 characteristics of the unit:

- reduces radiated noise power level around 4 dB(A)
- reduces condenser in duct noise power level up to -9 dB(A)
- able very low ambient cooling operations in full security

COMPACTAIR units being mostly installed inside buildings in urban environment, the noise created might be particularly annoying at certain moments: during the night for neighbourhood, for visitors in the day. Therefore, the Compactair operation mode can be selected at any time zone for Low Noise or Performance. The Low Noise mode might work with high performance results up to high external temperature.

This option also able cooling operation in very cold ambient T°C with good performance on condenser fan belt lifecycle extension and starting peak current reduction.

DC 50 : Comfort Display

This is Climatic 50 remote controller for non-technical customer. It has been wanted to aesthetically fit inside a room and be very easy to use. It can be installed at maximum 500 meters from the unit. This graphical display gives information such as running mode of the unit, status of the fan, set point, % of fresh air, outside air temperature.

Customer can change the scheduling of the different time zone, can modify temperature set point and % of fresh air for each zone. Customer can also override the scheduling in either changing the set point for 3 hours or in forcing the rooftop to unoccupied mode for 1 to 7 days. ON/OFF key is also available. DC50 Comfort display, shows faults number when rooftop is in the failure mode. Customer can reset fault thanks to a combination of keys. Time and day of the rooftop can be seen and modified easily through the DC50.

DS 50 : Service Display

This service display controller directly plugs on the external wall of the unit equipped by Climatic 50 control platform. This allows service personal to set up to 90 settings, read up to 125 variables, up to 45 faults and read the history of the last 16 faults.

This controller has been designed to be very user friendly, with 6 different keys, a 4 lines display and this controller includes scrolling menus and true language (no codes). It will be in English or an other alternate language.

DM 50: Multi-Unit Display

This Climatic 50 display offers the same possibilities than DC 50 Customer Display applied to 12 units.

Extension control board - BE50

This board enables extra inlet and outlet to the Climatic 50. Allow 4 analogical inputs, 4 digital inputs and 4 digital outputs.

Depending to the optional equipment selected, this equipment might be already available in the unit.

Modbus Communication interface

This is a modbus interface, which is needed for anyone who would like a BMS system to talk to the Compactair with "Modbus protocol". No other hardware is required to have modbus dialog.

LonTalk® interface

This board is a LonTalk® interface, which is needed for anyone who would like a BMS system to talk to the Compactair with

«Lon protocol » with FTT10. No other hardware than this board is required to have LonTalk® dialog. One board required per rooftop.

Bacnet® interface

This board is a Bacnet® interface, which is needed for anyone who would like a BMS system to talk to the Compactair with "Bacnet protocol" RS485.

TCB (Thermostat Control Board)

This board has been developed for any customer who wants to take over the control of the unit. With 6 logical inputs (Compressor stage 1 and stage 2, heating step 1 and 2, 4 way valves and fan), this board will replace the control algorithm. However CLIMATIC™ 50 controller will stay in charge of all safety algorithm, defrost operation or free cooling operation. All Input are volt free contact. This is the perfect board, to have Compactair managed by a zoning system, a universal thermostat or even a BMS system.

Adalink Distant Monitoring

Adalink is the solution for Retail & Light Commercial HVAC installation monitoring. It can control up to 32 units on the same site. Real gateway to the unit, Adalink can be used locally, via LAN network or directly plugged. It can be used remotely via modem. Adalink can show the whole site map showing status of the different units, zoom on each unit and allow the user to graphically change set point, access alarm list, look at trend curves.

It is the ideal tools for maintenance specialist with an expert mode giving access to all the parameters and set point of the unit. Finally, yearly scheduling is possible with a very smart and userfriendly drag and drop system.

Table 1.1

Options		Models				
		Monobloc	Split	Dual Split	Cooling only	Heat Pump
Climatic™ 50 control platform		x	x	-	x	x
Air treatment section						
Fresh Air						
Economizer module				x		
Exhaust module				x		
Return module		Sizes 55 -100		-	Sizes 55 -100	
Airflow configuration		Refer to airflow configuration page 51				
Indoor air quality						
Air quality sensor	CL50	x	x	-	x	x
High filtration level - G4 prefilter / F7 filtration				x		
Dirty filter sensor		x	x	x	x	x
Analog dirty filter and fan control	CL50	x	x	-	x	x
Auxiliar Heater						
Electrical heater standard -1 step				x		
Electrical heater medium - 2 steps				x		
Electrical heater high - 2 steps				x		
Electrical heater high - modulating capacity	CL50	x	x	-	x	x
Hot water coil - 1 step				x		
Hot water coil - modulating capacity	CL50	x	x	-	x	x
Control						
Smoke detector				x		
Air socks control				x		
Ambient remote sensor				x		
Remote duct sensor				x		
Condensing unit						
Refrigeration option						
Winter cooling operations down 0 °C		x	x	x	x	STD
Service valves		-	x	x	x	x
Refrigerant precharged		STD	x	x	x	x
Long distance refrigerant connection 65 m		-	x	x	x	x
Electrical and Safety						
Main switch				x		
Compressor electrical protection				x		
Control & Communication						
Advanced control for enthalpy and humidity	CL50	x	x	-	x	x
Modbus				x		
LONWork Echelon	CL50	x	x	-	x	x
BACNet	CL50	x	x	-	x	x
Customer display DC50	CL50	x	x	-	x	x
Service display DS50	CL50	x	x	-	x	x
Multi-unit display DM 50	CL50	x	x	-	x	x
Extension control board - BE 50	CL50	x	x	-	x	x
TCB: connection for voltage free contact control	CL50	x	x	-	x	x
Other options						
Inverter low noise control - Winter cooling operation down -15°C				x		
Vertical air discharge condensing units		-	x	x	x	x
Coil anticorrosion protection outdoor				x		
Coil anticorrosion protection outdoor & indoor				x		

Table 2.1

COMPACTAIR™			20 S	25 S	30 S	35 S	40 S	
SET								
Capacity	Gross cooling capacity ⁽¹⁾	kW	19,6	25,0	28,0	36,0	42,0	
	Total absorbed power ⁽¹⁾	kW	7,3	9,2	11,0	13,7	15,9	
	Gross EER			2,7	2,7	2,5	2,6	2,6
	Net heating capacity	kW	19,25	25,0	29,5	36,0	42	
	Absorbed power	kW	6,64	8,62	10,7	12,4	14,0	
	Net COP			2,9	2,9	2,75	2,9	3,0
Casing	Material	Galvanized sheet steel casing						
	Paint	EPOXY - RAL 9002						
AIR TREATMENT SECTION								
Ventilation	Nominal airflow	m ³ /h	3700	5000	5450	7100	8150	
	Minimum airflow	m ³ /h	3150	4250	4650	6200	6950	
	Maximum airflow	m ³ /h	4100	5500	6000	8050	9050	
	Maximum ESP	Pa	450	550	550	550	600	
	Fan type		Centrifugal type					
	Number of fans			1	1	1	1	1
Filtration	Standard filtration		G4 - 50 mm					
	Quantity		2	2	2	3	3	
	Size		565 x 503	565 x 503	565 x 503	660 x 420	660 x 420	
Insulation class			M1					
COMPRESSOR SECTION								
Ventilation	Fan type		Centrifugal type					
	Number of fans		1	1	1	1	1	
	Nominal airflow at 100 Pa	m ³ /h	7600	8500	10000	12000	11700	
	Maximum ESP	Pa	178	223	272	209	205	
Refrigerant circuit	Refrigerant type		R410A					
	Type of compressor		Scroll					
	Capacity steps		1	1	1	1	1	
	Refrigerant charge per circuit ⁽²⁾	kg	4,5	5,5	6,2	8,05	9,3	
Insulation class			M1					
OPERATING LIMITS								
Cooling mode	Maxi. outdoor temperature (at indoor 27°C DB / 19°C WB)	°C	+ 46					
	Mini. outdoor temperature (at indoor 20°C DB)	°C	+ 15°C on C/O and 0°C on HP					
	Mini. outdoor temperature (at 21°C DB/16°C WB with winter cooling operation kit)	°C	- 15°C					
Heating mode	Mini. outdoor temperature (at indoor 20°C DB)	°C	- 12°C with 20°C indoor temperature					
	Maxi. outdoor temperature (at indoor 26°C DB / 19°C WB)	°C	20 °C					
ACOUSTIC								
Outdoor blower outlet sound power on standard unit (Lw)	dB(A)	80	83	86	84	84		
Mini outdoor blower outlet sound power with Inverter low noise control (Lw)	dB(A)	73	74	77	75	75		
Radiated sound power level in room on standard outdoor unit (Lw)	dB(A)	75	76	79	77	78		
Mini radiated sound power level in room with Inverter low noise control (Lw)	dB(A)	71	72	75	73	73		
Indoor blower outlet sound power level	dB(A)	73	78	80	80	83		

(1) EUROVENT Conditions.

(2) Measured on monobloc heat pump version

COMPACTAIR™ is part of AC2/AC Eurovent Certification Programs (www.eurovent-certification.com)

Table 2.2

COMPACTAIR™			45 D	55 D	70 D	85 D	100 D
SET							
Capacity	Gross cooling capacity ⁽¹⁾	kW	48,0	58,0	72,0	87,0	105,0
	Total absorbed power ⁽¹⁾	kW	18,8	21,5	27,8	32,5	40,4
	Gross EER		2,6	2,7	2,6	2,7	2,6
	Net heating capacity	kW	49,5	59	69,5	81	101
	Absorbed power	kW	17,4	20,3	24,8	28,4	35,4
	Net COP		2,85	2,9	2,8	2,85	2,85
Casing	Material	Galvanized sheet steel casing					
	Paint	EPOXY - RAL 9002					
AIR TREATMENT SECTION							
Ventilation	Nominal airflow	m ³ /h	9400	11700	14650	16250	20400
	Minimum airflow	m ³ /h	7950	9950	12450	14000	17350
	Maximum airflow	m ³ /h	9750	12850	15090	16725	22450
	Maximum ESP	Pa	550	650	650	600	600
	Fan type	Centrifugal type					
	Number of fans (outlets)		1	2	2	2	2
Filtration	Standard filtration	G4 - 50 mm					
	Quantity		3	5	5	5	8
	Size		660 x 420	660 x 420	660 x 420	660 x 420	504 x 665
Insulation class	M1						
COMPRESSOR SECTION							
Ventilation	Fan type	Centrifugal type					
	Number of fans		1	2	2	2	2
	Nominal airflow at 100 Pa	m ³ /h	14000	20000	21000	22000	15500 + 11700
	Maximum ESP	Pa	237	299	272	277	239 + 201
Refrigerant circuit	Refrigerant type	R410A					
	Type of compressor	Scroll					
	Capacity steps		2	2	2	2	2
	Refrigerant charge per circuit ⁽²⁾	kg	3+3	6,3+6,3	8+8	9,55+9,55	13,45+9,5
Insulation class	M1						
OPERATING LIMITS							
Cooling mode	Maxi. outdoor temperature (at indoor 27°C DB / 19°C WB)	°C	+ 46				
	Mini. outdoor temperature (at indoor 20°C DB)	°C	+ 15°C on C/O and 0°C on HP				
	Mini. outdoor temperature (at 21°C DB/16°C WB with winter cooling operation kit)	°C	- 15°C				
Heating mode	Mini. outdoor temperature (at indoor 20°C DB)	°C	- 12°C with 20°C indoor temperature				
	Maxi. outdoor temperature (at indoor 26°C DB / 19°C WB)	°C	20 °C				
ACOUSTIC							
Outdoor blower outlet sound power on standard unit (Lw)	dB(A)	88	87	88	89	92	
Mini outdoor blower outlet sound power with Inverter low noise control (Lw)	dB(A)	78	78	79	80	83	
Radiated sound power level in room on standard outdoor unit (Lw)	dB(A)	79	82	80	81	83	
Mini radiated sound power level in room with Inverter low noise control (Lw)	dB(A)	74	76	77	78	79	
Indoor blower outlet sound power level	dB(A)	86	80	85	87	85	

(1) EUROVENT Conditions

(2) Measured on monobloc heat pump version except size 100D

COMPACTAIR™ is part of AC2/AC Eurovent Certification Programs (www.eurovent-certification.com)

STEP 1 : INPUT

Calculate the total and sensible loads of the area to be conditioned at design conditions.

- A. Total cooling load in kW
- B. Summer design condition – Winter design conditions
- C. Air flow needed percentage of fresh air and external static pressure (to overcome system losses, eg ductwork, diffusers.)
- D. Accessories needed

STEP 2 : COOLING CAPACITY

- A. Preselect the equipment using ‘general data’ in tables 2.1-2.2 to find units close to the required capacity.
- B. Size the equipment using the ‘cooling performance’ in tables 4.1-4.13 to match the cooling loads at design conditions.
- C. To establish the net capacity, the supply and condenser fan motor power should be subtracted.
Review the supply fan performance in tables 3.1-3.10 with the required air flow and static pressure (do not forget to add the pressure drop for accessories in table 3.15)
Review the condenser fan performance in tables 3.1-3.10 with the static pressure required.

STEP 3 : HEATING CAPACITY

- A. Heat pump (*)
The selection procedure is the same as that undertaken for cooling.
Preselect equipment in “General data” in tables 2.1-.2.2
Obtain the net heating capacity at design condition (winter conditions) from tables 4.1-4.13.
Obtain the net capacity by adding the supply fan power (selected above) to the gross capacity.
- B. Other Heating
Select hot water coil in tables 4.2, electric heater in table 4.3.

(*) : This procedure doesn't take into account the impact of defrost in the heating performance. Depending on the outdoor moisture and temperature condition, the defrost operation might reduce the heat pump capacity.

STEP 4 : ELECTRICAL DATA

Data from table 5.1-5.3

- A. Heat pump unit

$$Pa = P(\text{Unit} + \Delta \text{supply fan kit} + \text{Exhaust module} + \text{Electric heater} + \Delta \text{PLn})$$

$$Ia = Ia(\text{Unit} + \Delta \text{supply fan kit} + \text{Exhaust module} + \text{Electric heater} + \Delta \text{ILn})$$

$$Id/Ia(\text{base}) = \text{Table 5.1} - 5.2$$

$$Id = Ia(\text{base}) \times Id/Ia(\text{base}) + Ia(\Delta \text{supply fan kit} + \text{Exhaust module} + \text{Electric heater})$$
- B. Cooling unit

$$P1, Ia1 (\text{summer operation}) = P, Ia(\text{Unit} + \Delta \text{fan kit supply} + \text{Exhaust module})$$

$$P2 (\text{winter operation}) = P(\Delta \text{supply fan kit} + \text{Exhaust module} + \text{Electric heater})$$

$$Ia2 (\text{winter operation}) = Ia(\Delta \text{supply fan kit} + \text{Exhaust module} + \text{Electric heater})$$

$$Pa = \max(P1; P2)$$

$$Ia = \max(Ia1; Ia2)$$

$$Id/Ia(\text{base}) = \text{Table 5.1-5.3}$$

$$Id = Ia(\text{base}) \times Id/Ia(\text{base}) + Ia(\Delta \text{kit indoor optional} + \text{Exhaust module} + \text{Electric heater} + \text{gas})$$

EXAMPLE

STEP 1

- A. 32kW
- B. Summer :35°C outdoor temperature, 24°C DB, 19°C WB entering air condition (room return air)
Winter : -5°C outdoor temperature, 20°C DB entering air condition (room return air)
- C. 6 200 m3/h at 200Pa
- D. Economiser and 20 kW electric heater.

STEP 2

- A. Table 2.1 shows that CMH 035 will give 36 kW gross at nominal operating conditions.
- B. Table 4.4a shows that a CMH 035 has a gross cooling capacity of 35,6 kW.
- C. Table 3.15 shows that economiser and 20 kW electric heater will add 20 Pa to the external static specified, giving a total of 220 Pa.
The table 4.4 shows that high pressure fan (0,9 kW) is required for a CMH 035. providing 6 200 m³/h at 207 Pa.
The net capacity is therefore
 $35,6 \text{ kW} - 0,9 \text{ kW} = 34,7 \text{ kW}$

STEP 3

- A. Table 2.1 shows that CMH 035 will give 36 kW gross at nominal operating conditions.
- B. The table 3.15 shows that high pressure fan (0,9 kW) is required for a CMH 035 providing 6 200 m³/h at 207 Pa.

The net capacity is therefore
 $26,9 \text{ kW} + 0,9 \text{ kW} = 27,8 \text{ kW}$
The table 4.3 shows that a 20kW electrical heater is required.
The net capacity is therefore :
 $26,9 \text{ kW} + 0,9 \text{ kW} + 20 \text{ kW} = 47,8 \text{ kW}$

STEP 4

- A. Table 5.1 -5.3 shows that a CMH 035 With 20 kW Electric heater + High pressure fan
 $Ia1 = 33,9 + 1,35 = 35,3 \text{ A}$
 $P1 = 20,08 + 0,9 = 22,0 \text{ kW}$

 $Ia2 = 33,9 + 1,35 + 30,1 = 65,4 \text{ A}$
 $P2 = 20,08 + 0,9 + 20 = 41,0 \text{ kW}$

 $P2 > P1$ so $P = P2 = 41,0 \text{ kW}$
 $Ia2 > Ia1$ so $Ia = Ia2 = 65,4 \text{ A}$

 $Id/Ia = 4.2$
 $Id = 33,9 \times 4.2 + 0,9 + 30,1 = 173,4 \text{ A}$

TREATMENT VENTILATION DATA

Table 3.1

Size 20S	ASP	100 Pa			150 Pa			200 Pa			250 Pa		
	Airflow (m³/h)	Kit	PI	rpm	Kit	PI	rpm	Kit	PI	rpm	Kit	PI	rpm
	3150	STD	1x0,55	682	STD	1x0,55	788	HP1	1x1,1	890	HP1	1x1,1	980
	3425	STD	1x0,55	699	STD	1x0,55	800	HP1	1x1,1	896	HP1	1x1,1	984
	3700	STD	1x0,55	717	STD	1x0,55	813	HP1	1x1,1	909	HP1	1x1,1	991
	4100	STD	1x0,55	735	No kit			HP1	1x1,1	921	HP1	1x1,1	1003
	ASP	300 Pa			350 Pa			400 Pa			450 Pa		
	Airflow (m³/h)	Kit	PI	rpm	Kit	PI	rpm	Kit	PI	rpm	Kit	PI	rpm
	3150	HP1	1x1,1	1060	HP2	1x1,1	1133	HP3	1x1,5	1204	HP3	1x1,5	1275
	3425	HP1	1x1,1	1068	HP2	1x1,1	1135	HP3	1x1,5	1214	HP3	1x1,5	1281
3700	HP1	1x1,1	1074	HP2	1x1,1	1138	HP3	1x1,5	1220	HP3	1x1,5	1289	
4100	HP1	1x1,1	1083	HP2	1x1,1	1141	HP3	1x1,5	1233	HP3	1x1,5	1293	

Table 3.2

Size 25S	ASP	100 Pa			150 Pa			200 Pa			250 Pa			300 Pa		
	Airflow (m³/h)	Kit	PI	rpm	Kit	PI	rpm	Kit	PI	rpm	Kit	PI	rpm	Kit	P	rpm
	4250	STD	1x1,1	753	STD	1x1,1	840	HP1	1x1,5	915	HP1	1x1,5	1009	HP1	1x1,5	1085
	4625	STD	1x1,1	770	HP1	1x1,5	860	HP1	1x1,5	942	HP1	1x1,5	1021	HP1	1x1,5	1098
	5000	STD	1x1,1	806	HP1	1x1,5	883	HP1	1x1,5	956	HP1	1x1,5	1035	HP2	1x1,5	1091
	5500	STD	1x1,1	840	HP1	1x1,5	903	HP1	1x1,5	988	HP1	1x1,5	1059	HP2	1x1,5	1098
	ASP	350 Pa			400 Pa			450 Pa			500 Pa			550 Pa		
	Airflow (m³/h)	Kit	PI	rpm	Kit	PI	rpm	Kit	PI	rpm	Kit	PI	rpm	Kit	P	rpm
	4250	HP2	1x1,5	1160	HP2	1x1,5	1233	HP2	1x1,5	1279	HP3	1x2,2	1358	HP3	1x2,2	1420
	4625	HP2	1x1,5	1169	HP2	1x1,5	1238	HP2	1x1,5	1281	HP3	1x2,2	1364	HP3	1x2,2	1426
5000	HP2	1x1,5	1176	HP2	1x1,5	1246	HP3	1x2,2	1310	HP3	1x2,2	1371	HP3	1x2,2	1431	
5500	HP3	1x2,2	1195	HP3	1x2,2	1258	HP3	1x2,2	1321	HP3	1x2,2	1380	HP3	1x2,2	1441	

Table 3.3

Size 30S	ASP	100 Pa			150 Pa			200 Pa			250 Pa			300 Pa		
	Airflow (m³/h)	Kit	PI	rpm	Kit	PI	rpm	Kit	PI	rpm	Kit	PI	rpm	Kit	P	rpm
	4650	STD	1x1,1	797	STD	1x1,1	876	HP1	1x1,5	956	HP1	1x1,5	1038	HP2	1x2,2	1113
	5050	STD	1x1,1	822	STD	1x1,1	903	HP1	1x1,5	980	HP1	1x1,5	1051	HP2	1x2,2	1126
	5450	STD	1x1,1	856	HP1	1x1,5	932	HP1	1x1,5	1003	HP1	1x1,5	1074	HP2	1x2,2	1141
	6000	STD	1x1,1	895	HP1	1x1,5	970	HP1	1x1,5	1034	HP1	1x1,5	1098	HP2	1x2,2	1161
	ASP	350 Pa			400 Pa			450 Pa			500 Pa			550 Pa		
	Airflow (m³/h)	Kit	PI	rpm	Kit	PI	rpm	Kit	PI	rpm	Kit	PI	rpm	Kit	P	rpm
	4650	HP2	1x2,2	1184	HP2	1x2,2	1251	HP2	1x2,2	1295	HP3	1x3	1380	HP3	1x3	1438
	5050	HP2	1x2,2	1197	HP2	1x2,2	1261	HP2	1x2,2	1298	HP3	1x3	1386	HP3	1x3	1445
5450	HP2	1x2,2	1208	HP2	1x2,2	1271	HP2	1x2,2	1303	HP3	1x3	1395	HP3	1x3	1453	
6000	HP2	1x2,2	1227	HP2	1x2,2	1278	HP3	1x3	1349	HP3	1x3	1407	HP3	1x3	1465	

Table 3.4

Size 35S	ASP	100 Pa			150 Pa			200 Pa			250 Pa			300 Pa		
	Airflow (m³/h)	Kit	PI	rpm	Kit	PI	rpm	Kit	PI	rpm	Kit	PI	rpm	Kit	P	rpm
	6200	STD	1x1,5	640	STD	1x1,5	720	HP1	1x2,2	788	HP1	1x2,2	849	HP1	1x2,2	912
	6650	STD	1x1,5	663	STD	1x1,5	735	HP1	1x2,2	797	HP1	1x2,2	863	HP1	1x2,2	922
	7100	STD	1x1,5	688	HP1	1x2,2	749	HP1	1x2,2	813	HP1	1x2,2	873	HP1	1x2,2	931
	8050	STD	1x1,5	735	HP1	1x2,2	788	HP1	1x2,2	848	HP1	1x2,2	903	HP2	1x3	956
	ASP	350 Pa			400 Pa			450 Pa			500 Pa			550 Pa		
	Airflow (m³/h)	Kit	PI	rpm	Kit	PI	rpm	Kit	PI	rpm	Kit	PI	rpm	Kit	P	rpm
	6200	HP2	1x3	972	HP2	1x3	1028	HP2	1x3	1066	HP3	1x3	1134	HP3	1x3	1183
	6650	HP2	1x3	979	HP2	1x3	1035	HP2	1x3	1068	HP3	1x3	1139	HP3	1x3	1188
7100	HP2	1x3	986	HP2	1x3	1044	HP2	1x3	1071	HP3	1x3	1144	No kit			
8050	HP2	1x3	1010	HP2	1x3	1052	HP3	1x3	1111	HP3	1x3	1159	No kit			

ASP (Pa) Available static pressure **PI (kW)** Power input

TREATMENT VENTILATION DATA

Table 3.5

Size 40D	ASP	100 Pa			150 Pa			200 Pa			250 Pa			300 Pa			350 Pa		
	Airflow (m³/h)	Kit	PI	rpm	Kit	PI	rpm	Kit	PI	rpm	Kit	PI	rpm	Kit	PI	rpm	Kit	PI	rpm
	6950	STD	1x2,2	690	STD	1x2,2	757	STD	1x2,2	821	HP1	1x2,2	882	HP2	1x3	940	HP2	1x3	997
7550	STD	1x2,2	726	STD	1x2,2	782	HP1	1x2,2	838	HP1	1x2,2	900	HP2	1x3	956	HP2	1x3	1010	
8150	STD	1x2,2	748	STD	1x2,2	808	HP1	1x2,2	863	HP1	1x2,2	919	HP2	1x3	973	HP2	1x3	1024	
9050	STD	1x2,2	799	HP1	1x2,2	851	HP1	1x2,2	902	HP2	1x3	951	HP2	1x3	1002	HP2	1x3	1069	
Size 40D	ASP	400 Pa			450 Pa			500 Pa			550 Pa			600 Pa					
	Airflow (m³/h)	Kit	PI	rpm	Kit	PI	rpm	Kit	PI	rpm	Kit	PI	rpm	Kit	PI	rpm			
	6950	HP2	1x3	1048	HP2	1x3	1103	HP3	1x4	1154	HP3	1x4	1202	HP3	1x4	1250			
	7550	HP2	1x3	1053	HP3	1x4	1117	HP3	1x4	1162	HP3	1x4	1209	No kit					
	8150	HP2	1x3	1059	HP3	1x4	1125	HP3	1x4	1172	HP3	1x4	1216	No kit					
9050	HP2	1x3	1069	HP3	1x4	1144	HP3	1x4	1189	HP3	1x4	1233	No kit						

Table 3.6

Size 45D	ASP	100 Pa			150 Pa			200 Pa			250 Pa			300 Pa		
	Airflow (m³/h)	Kit	PI	rpm	Kit	PI	rpm	Kit	PI	rpm	Kit	PI	rpm	Kit	PI	rpm
	7950	STD	1x2,2	738	STD	1x2,2	800	HP1	1x3	857	HP1	1x3	912	HP1	1x3	967
8675	STD	1x2,2	779	STD	1x2,2	833	HP1	1x3	886	HP1	1x3	938	HP1	1x3	986	
9400	STD	1x2,2	817	STD	1x2,2	867	HP1	1x3	917	HP1	1x3	966	HP1	1x3	1014	
9750	STD	1x2,2	838	HP1	1x3	884	HP1	1x3	931	HP1	1x3	979	HP1	1x3	1027	
Size 45D	ASP	350 Pa			400 Pa			450 Pa			500 Pa			550 Pa		
	Airflow (m³/h)	Kit	PI	rpm	Kit	PI	rpm	Kit	PI	rpm	Kit	PI	rpm	Kit	PI	rpm
	7950	HP1	1x3	1019	HP2	1x4	1058	HP3	1x4	1154	HP3	1x4	1168	HP3	1x4	1216
	8675	HP1	1x3	1041	HP2	1x4	1064	HP3	1x4	1136	HP3	1x4	1183	HP3	1x4	1226
	9400	HP2	1x4	1052	HP2	1x4	1073	HP3	1x4	1150	HP3	1x4	1196	HP3	1x4	1240
9750	HP2	1x4	1056	HP3	1x4	1117	HP3	1x4	1161	HP3	1x4	1204	HP3	1x4	1250	

Table 3.7

Size 55D	ASP	100 Pa			150 Pa			200 Pa			250 Pa			300 Pa			350 Pa		
	Airflow (m³/h)	Kit	PI	rpm	Kit	PI	rpm	Kit	PI	rpm	Kit	PI	rpm	Kit	PI	rpm	Kit	PI	rpm
	9950	STD	1x2,2	666	STD	1x2,2	748	STD	1x2,2	828	HP1	1x3	903	HP1	1x3	967	HP1	1x3	1033
10825	STD	1x2,2	688	STD	1x2,2	770	HP1	1x3	842	HP1	1x3	913	HP1	1x3	986	HP1	1x3	1041	
11700	STD	1x2,2	704	STD	1x2,2	786	HP1	1x3	859	HP1	1x3	931	HP1	1x3	992	HP2	1x4	1010	
12850	STD	1x2,2	741	HP1	1x3	820	HP1	1x3	881	HP1	1x3	946	HP2	1x4	971	HP2	1x4	1027	
Size 55D	ASP	400 Pa			450 Pa			500 Pa			550 Pa			600 Pa			650 Pa		
	Airflow (m³/h)	Kit	PI	rpm	Kit	PI	rpm	Kit	PI	rpm	Kit	PI	rpm	Kit	PI	rpm	Kit	PI	rpm
	9950	HP2	1x4	1047	HP2	1x4	1103	HP2	1x4	1138	HP3	1x5,5	1207	HP3	1x5,5	1256	HP3	1x5,5	1303
	10825	HP2	1x4	1057	HP2	1x4	1109	HP2	1x4	1140	HP3	1x5,5	1214	HP3	1x5,5	1262	HP3	1x5,5	1309
	11700	HP2	1x4	1065	HP2	1x4	1115	HP2	1x4	1172	HP3	1x5,5	1220	HP3	1x5,5	1268	No kit		
12850	HP2	1x4	1078	HP3	1x5,5	1132	HP3	1x5,5	1182	HP3	1x5,5	1232	No kit			No kit			

Table 3.8

Size 70D	ASP	100 Pa			150 Pa			200 Pa			250 Pa			300 Pa			350 Pa		
	Airflow (m³/h)	Kit	PI	rpm	Kit	PI	rpm	Kit	PI	rpm	Kit	PI	rpm	Kit	PI	rpm	Kit	PI	rpm
	12450	STD	1x3	738	STD	1x3	819	STD	1x3	888	HP1	1x4	959	HP1	1x4	1014	HP2	1x5,5	1033
13550	STD	1x3	776	STD	1x3	845	HP1	1x4	909	HP1	1x4	972	HP1	1x4	1033	HP2	1x5,5	1047	
14650	STD	1x3	807	HP1	1x4	871	HP1	1x4	931	HP1	1x4	993	HP2	1x5,5	1016	HP2	1x5,5	1069	
15090	STD	1x3	819	HP1	1x4	882	HP1	1x4	943	HP1	1x4	1002	HP2	1x5,5	1027	HP2	1x5,5	1078	
Size 70D	ASP	400 Pa			450 Pa			500 Pa			550 Pa			600 Pa			650 Pa		
	Airflow (m³/h)	Kit	PI	rpm	Kit	PI	rpm	Kit	PI	rpm	Kit	PI	rpm	Kit	PI	rpm	Kit	PI	rpm
	12450	HP2	1x5,5	1087	HP2	1x5,5	1125	HP3	1x7,5	1189	HP3	1x7,5	1237	HP3	1x7,5	1275	HP3	1x7,5	1329
	13550	HP2	1x5,5	1101	HP2	1x5,5	1130	HP3	1x7,5	1197	HP3	1x7,5	1245	HP3	1x7,5	1292	HP3	1x7,5	1339
	14650	HP2	1x5,5	1113	HP2	1x5,5	1137	HP3	1x7,5	1212	HP3	1x7,5	1258	HP3	1x7,5	1303	No kit		
15090	HP2	1x5,5	1117	HP2	1x5,5	1140	HP3	1x7,5	1218	HP3	1x7,5	1264	HP3	1x7,5	1307	No kit			

ASP (Pa) Available static pressure PI (kW) Power input

TREATMENT VENTILATION DATA

Table 3.9

Size 85D	ASP	100 Pa			150 Pa			200 Pa			250 Pa			300 Pa			350 Pa		
	Airflow (m³/h)	Kit	PI	rpm	Kit	PI	rpm	Kit	PI	rpm	Kit	PI	rpm	Kit	PI	rpm	Kit	PI	rpm
	14000	STD	1x4	805	STD	1x4	872	STD	1x4	937	HP1	1x5,5	995	HP2	1x7,5	1016	HP2	1x7,5	1070
	15125	STD	1x4	838	STD	1x4	898	HP1	1x5,5	959	HP1	1x5,5	1014	HP2	1x7,5	1040	HP2	1x7,5	1088
	16250	STD	1x4	863	STD	1x4	925	HP1	1x5,5	986	HP1	1x5,5	1041	HP2	1x7,5	1064	HP2	1x7,5	1109
	16725	STD	1x4	882	STD	1x4	937	HP1	1x5,5	994	HP2	1x7,5	1029	HP2	1x7,5	1073	HP2	1x7,5	1114
	ASP	400 Pa			450 Pa			500 Pa			550 Pa			600 Pa					
	Airflow (m³/h)	Kit	PI	rpm	Kit	PI	rpm	Kit	PI	rpm	Kit	PI	rpm	Kit	PI	rpm			
	14000	HP2	1x7,5	1114	HP2	1x7,5	1172	HP3	1x7,5	1214	HP3	1x7,5	1262	HP3	1x7,5	1303			
	15125	HP2	1x7,5	1122	HP3	1x7,5	1184	HP3	1x7,5	1232	HP3	1x7,5	1275	HP3	1x7,5	1310			
16250	HP2	1x7,5	1130	HP3	1x7,5	1201	HP3	1x7,5	1245	HP3	1x7,5	1289	HP3	1x7,5	1331				
16725	HP2	1x7,5	1134	HP3	1x7,5	1209	HP3	1x7,5	1253	HP3	1x7,5	1295	HP3	1x7,5	1339				

Table 3.10

Size 100D	ASP	100 Pa			150 Pa			200 Pa			250 Pa			300 Pa			350 Pa		
	Airflow (m³/h)	Kit	PI	rpm	Kit	PI	rpm	Kit	PI	rpm	Kit	PI	rpm	Kit	PI	rpm	Kit	PI	rpm
	17350	STD	1x4	591	STD	1x4	650	STD	1x4	710	HP1	1x5,5	763	HP1	1x5,5	815	HP2	2x4	825
	18875	STD	1x4	611	STD	1x4	670	STD	1x4	730	HP1	1x5,5	777	HP1	1x5,5	827	HP2	2x4	834
	20400	STD	1x4	637	STD	1x4	690	HP1	1x5,5	744	HP1	1x5,5	792	HP2	2x4	802	HP2	2x4	846
	22450	STD	1x4	670	HP1	1x5,5	721	HP1	1x5,5	770	HP2	2x4	788	HP2	2x4	822	HP2	2x4	863
	ASP	400 Pa			450 Pa			500 Pa			550 Pa			600 Pa					
	Airflow (m³/h)	Kit	PI	rpm	Kit	PI	rpm	Kit	PI	rpm	Kit	PI	rpm	Kit	PI	rpm			
	17350	HP2	2x4	870	HP2	2x4	903	HP3	2x4	959	HP3	2x4	997	HP3	2x4	1036			
	18875	HP2	2x4	879	HP2	2x4	906	HP3	2x4	964	HP3	2x4	1003	HP3	2x4	1041			
20400	HP2	2x4	888	HP2	2x4	910	HP3	2x4	971	HP3	2x4	1009	No kit						
22450	HP2	2x4	896	HP3	2x4	945	HP3	2x4	986	No kit			No kit						

RETURN VENTILATION DATA

Table 3.11

55 D Return fan		Airflow (m³/h)							
		9950		10825		11700		12850	
Airflow (rpm)		ASP	PI	ASP	PI	ASP	PI	ASP	PI
Closed pulley		755	255 2,37	257 2,56	260 2,77	260 3,05			
Pulley position	1 turn	715	230 2,11	232 2,30	234 2,48	233 2,75			
	2 turns	675	207 1,88	208 2,05	210 2,23	207 2,48			
	3 turns	635	184 1,67	184 1,82	184 1,99	180 2,22			
	4 turns	595	162 1,47	162 1,61	160 1,77	155 1,98			

Table 3.12

70 D Return fan		Airflow (m³/h)							
		12450		13550		14650		15090	
Airflow (rpm)		ASP	PI	ASP	PI	ASP	PI	ASP	PI
Closed pulley		755	260 2,93	260 3,22	258 3,52	255 3,65			
Pulley position	1 turn	715	235 2,64	233 2,91	228 3,20	225 3,32			
	2 turns	675	208 2,37	205 2,62	198 2,90	195 3,00			
	3 turns	635	182 2,12	176 2,36	168 2,61	165 2,72			
	4 turns	595	157 1,89	150 2,11	140 2,35	135 2,44			

Table 3.13

85 D Return fan		Airflow (m³/h)							
		14000		15125		16250		16725	
Airflow (rpm)		ASP	PI	ASP	PI	ASP	PI	ASP	PI
Closed pulley		755	260 3,44	255 3,77	250 4,13				
Pulley position	1 turn	715	230 3,12	225 3,43	215 3,75	212 3,90			
	2 turns	675	202 2,82	195 3,11	183 3,41	178 3,55			
	3 turns	635	173 2,53	165 2,80	153 3,09	145 3,22			
	4 turns	595	145 2,27	135 2,52	120 2,79	115 2,91			

Table 3.14

100 D Return fan		Airflow (m³/h)							
		17350		18875		20400		22450	
Airflow (rpm)		ASP	PI	ASP	PI	ASP	PI	ASP	PI
Closed pulley		672	293 3,81	293 4,25	291 4,60				
Pulley position	1 turn	636	263 3,46	261 2,88	258 4,22	251 4,77			
	2 turns	601	234 3,15	232 3,49	227 3,86	218 4,38			
	3 turns	565	205 2,83	202 3,15	196 3,48	185 3,98			
	4 turns	529	178 2,52	173 2,81	166 3,13	153 3,58			

ASP (Pa) Available static pressure

PI (kW) Power input

OPTION PRESSURE DROP TABLE

Table 3.15

Unit Size	020S				025S				030S				035S			
Airflow (m³/h)	3150	3425	3700	4100	4250	4625	5000	5500	4650	5050	5450	6000	6200	6650	7100	8050
Options																
Economizer (Pa)	13	17	20	25	24	31	37	45	28	37	43	54	26	30	34	43
G4/F7 filtration (Pa)	85	93	102	115	120	133	146	165	133	148	163	184	128	140	152	178
Hot water coil (Pa)	15	17	20	23	25	28	32	38	29	33	37	44	25	29	32	39

Unit Size	040S				045D				055D			
Airflow (m³/h)	6950	7550	8150	9050	7950	8675	9400	9750	9950	10825	11700	12850
Options												
Economizer (Pa)	33	38	44	52	42	48	55	58	11	13	16	19
G4/F7 filtration (Pa)	148	164	181	208	175	197	219	230	123	136	150	169
Hot water coil (Pa)	31	35	40	47	38	44	50	54	24	27	31	36

Unit Size	070D				085D				100D			
Airflow (m³/h)	12450	13550	14650	15090	14000	15125	16250	16725	17350	18875	20400	22450
Options												
Economizer (Pa)	18	21	24	26	22	26	30	32	5	10	15	20
G4/F7 filtration (Pa)	162	181	200	208	188	209	230	239	135	150	166	187
Hot water coil (Pa)	34	39	44	47	41	47	53	55	23	26	30	35

CONDENSER VENTILATION DATA

Table 3.16	CMC / CMH CSC / CSH 20 S	External static pressure	Pa	35	47	101	151	178	
		Airflow	m ³ /h	7600	7600	6100	5700	5300	
		Fan rotation speed	rpm	621	654	654	719	751	
		Fan motor power input	kW	1,11	1,20	0,86	0,93	0,92	
Table 3.17	CMC / CMH CSC / CSH 25 S	External static pressure	Pa	40	63	107	148	223	
		Airflow	m ³ /h	8500	8500	8500	6800	5950	
		Fan rotation speed	rpm	696	732	805	769	841	
		Fan motor power input	kW	1,56	1,68	1,93	1,31	1,3	
Table 3.18	CMC / CMH CSC / CSH 30 S	External static pressure	Pa	36	55	106	146	272	
		Airflow	m ³ /h	10000	10000	9000	8000	7000	
		Fan rotation speed	rpm	773	814	814	814	934	
		Fan motor power input	kW	2,33	2,51	2,12	1,79	1,89	
Table 3.19	CMC / CMH CSC / CSH 35 S	External static pressure	Pa	50	107	152	209		
		Airflow	m ³ /h	12850	12000	10800	8400		
		Fan rotation speed	rpm	613	677	709	741		
		Fan motor power input	kW	2,04	2,13	1,98	1,56		
Table 3.20	CMC / CMH CSC / CSH 40 S	External static pressure	Pa	51	87	128	168	205	
		Airflow	m ³ /h	12500	11700	10525	9350	8200	
		Fan rotation speed	rpm	613	645	677	709	741	
		Fan motor power input	kW	1,97	1,90	1,76	1,63	1,51	
Table 3.21	CMC / CMH CSC / CSH 45 D	External static pressure	Pa	57	86	104	156	237	
		Airflow	m ³ /h	14000	14000	12600	12600	9800	
		Fan rotation speed	rpm	686	758	722	794	829	
		Fan motor power input	kW	2,71	3,15	2,50	2,91	2,27	
Table 3.22	CMC / CMH CSC / CSH CDC / CDH 55 D	External static pressure	Pa	73	105	149	206	299	
		Airflow	m ³ /h	20000	18000	16000	16000	14000	
		Fan rotation speed	rpm	645	613	613	677	741	
		Fan motor power input	kW	3,32	2,62	2,21	2,59	2,53	
Table 3.23	CMC / CMH CSC / CSH CDC / CDH 70 D	External static pressure	Pa	33	50	98	153	201	
		Airflow	m ³ /h	22400	22400	21000	18900	16800	
		Fan rotation speed	rpm	677	709	709	709	741	
		Fan motor power input	kW	4,22	4,53	4,11	3,53	2,99	
Table 3.24	CMC / CMH CSC / CSH CDC / CDH 85 D	External static pressure	Pa	36	51	101	154	277	
		Airflow	m ³ /h	23500	23500	22000	15400	15400	
		Fan rotation speed	rpm	686	719	719	621	751	
		Fan motor power input	kW	4,62	4,98	4,51	2,14	2,93	
Table 3.25	CMC / CMH CSC / CSH 100 D	Section 2	External static pressure	Pa	39	58	105	150	239
			Airflow	m ³ /h	13950	16600	13950	12400	10850
			Fan rotation speed	rpm	666	801	756	756	846
			Fan motor power input	kW	2,60	4,45	3,14	2,65	2,68
Table 3.26	CMC / CMH CSC / CSH 100 D	Section 2	External static pressure	Pa	46	101	148	201	
			Airflow	m ³ /h	12500	12500	9350	8200	
			Fan rotation speed	rpm	615	711	679	743	
			Fan motor power input	kW	2,00	2,45	1,53	1,53	

COOLING CAPACITIES

Table 4.1a

CMC - CMH 020 S			Air inlet temperature at condenser (dry bulb)																		
Mixed air temperature °C	Indoor wet bulb	Indoor dry bulb	20 °C			25 °C			30 °C			35 °C			40 °C			45 °C			
			GC	SC	AC	GC	SC	AC	GC	SC	AC	GC	SC	AC	GC	SC	AC	GC	SC	AC	
Minimum airflow	3150 m³/h	16	21	19,4	11,8	4,2	18,9	11,5	4,5	18,3	11,2	4,9	17,5	10,9	5,3	16,7	10,5	6,0	15,7	10,0	6,8
			24	19,5	14,5	4,2	18,9	14,2	4,5	18,3	13,9	4,9	17,6	13,5	5,3	16,8	13,0	6,0	15,8	12,4	6,9
			27	19,6	16,9	4,2	19,1	16,5	4,5	18,5	16,2	4,9	17,8	15,7	5,4	17,0	15,2	6,0	16,1	14,5	6,9
		19	24	21,2	11,5	4,3	20,6	11,3	4,6	19,9	11,0	5,0	19,1	10,7	5,5	18,2	10,3	6,1	17,2	9,9	7,0
			27	21,2	14,4	4,3	20,6	14,1	4,6	19,9	13,8	5,0	19,1	13,4	5,5	18,3	13,0	6,1	17,3	12,4	7,0
			30	21,3	16,8	4,3	20,7	16,5	4,6	20,1	16,1	5,0	19,3	15,7	5,5	18,4	15,2	6,2	17,4	14,6	7,0
		22	27	23,2	10,9	4,5	22,6	10,7	4,8	21,8	10,5	5,2	20,9	10,2	5,7	20,0	9,9	6,3	18,9	9,6	7,2
			30	23,2	13,9	4,5	22,5	13,7	4,8	21,8	13,4	5,2	20,9	13,1	5,7	20,0	12,7	6,3	18,9	12,3	7,2
			33	23,2	16,4	4,5	22,6	16,2	4,8	21,9	15,8	5,2	21,0	15,5	5,7	20,1	15,0	6,3	19,1	14,5	7,2
Nominal airflow	3700 m³/h	16	21	20,0	12,4	4,3	19,4	12,1	4,6	18,7	11,8	5,0	18,0	11,4	5,4	17,1	11,0	6,1	16,1	10,6	7,0
			24	20,0	15,4	4,3	19,5	15,1	4,6	18,8	14,7	5,0	18,1	14,3	5,5	17,2	13,7	6,1	16,3	13,2	7,0
			27	20,3	18,0	4,3	19,7	17,6	4,6	19,1	17,2	5,0	18,4	16,7	5,5	17,5	16,2	6,1	16,6	15,5	7,0
		19	24	21,7	12,2	4,4	21,1	11,9	4,7	20,4	11,6	5,1	19,5	11,3	5,6	18,6	11,0	6,2	17,6	10,5	7,1
			27	21,8	15,3	4,4	21,2	15,0	4,7	20,4	14,7	5,1	19,6	14,3	5,6	18,7	13,8	6,3	17,7	13,2	7,2
			30	22,0	17,9	4,4	21,4	17,6	4,7	20,7	17,2	5,1	19,9	16,8	5,6	19,0	16,2	6,3	17,9	15,6	7,2
		22	27	23,7	11,6	4,5	23,1	11,4	4,9	22,3	11,2	5,3	21,4	10,9	5,8	20,4	10,6	6,4	19,2	10,3	7,3
			30	23,8	14,9	4,5	23,1	14,6	4,9	22,3	14,3	5,3	21,4	14,0	5,8	20,4	13,6	6,4	19,3	13,1	7,4
			33	23,9	17,6	4,6	23,2	17,4	4,9	22,5	17,0	5,3	21,6	16,6	5,8	20,6	16,1	6,5	19,5	15,6	7,4
Maximum airflow	4100 m³/h	16	21	20,3	12,6	4,2	19,8	12,3	4,5	19,1	12,0	4,9	18,3	11,6	5,4	17,4	11,2	6,0	16,4	10,7	6,8
			24	20,5	15,7	4,2	19,9	15,4	4,5	19,2	15,0	4,9	18,5	14,6	5,4	17,6	14,1	6,0	16,6	13,5	6,8
			27	20,8	18,5	4,3	20,2	18,1	4,6	19,5	17,7	4,9	18,8	17,2	5,4	17,9	16,6	6,0	16,9	16,0	6,9
		19	24	22,1	12,4	4,4	21,5	12,1	4,7	20,7	11,8	5,0	19,9	11,5	5,5	18,9	11,1	6,1	17,8	10,7	7,0
			27	22,2	15,7	4,4	21,6	15,4	4,7	20,8	15,0	5,1	20,0	14,6	5,5	19,1	14,1	6,2	18,0	13,6	7,0
			30	22,5	18,5	4,4	21,8	18,2	4,7	21,1	17,8	5,1	20,3	17,3	5,6	19,4	16,7	6,2	18,3	16,1	7,0
		22	27	24,1	11,8	4,5	23,4	11,6	4,8	22,6	11,4	5,2	21,7	11,1	5,7	20,6	10,8	6,3	19,5	10,5	7,2
			30	24,2	15,3	4,5	23,5	15,0	4,8	22,7	14,7	5,2	21,8	14,4	5,7	20,8	14,0	6,4	19,7	13,5	7,2
			33	24,4	18,2	4,5	23,7	17,9	4,9	22,9	17,6	5,3	22,0	17,1	5,7	21,0	16,7	6,4	19,9	16,1	7,3

HEATING CAPACITIES

Table 4.1b

CMH/CSH+CIH 020 S			Air inlet temperature at condenser (dry bulb)													
Indoor Dry Bulb			-10 °C		-5 °C		0 °C		5 °C		7 °C		10 °C		15 °C	
			NH	AC	NH	AC	NH	AC	NH	AC	NH	AC	NH	AC	NH	AC
Minimum airflow	3150 m³/h	15	12,46	3,36	14,47	3,74	16,46	4,11	18,43	4,48	19,22	4,63	20,39	4,85	22,34	5,24
		18	12,46	3,66	14,42	4,05	16,37	4,43	18,30	4,81	19,07	4,96	20,22	5,20	22,12	5,61
		20	12,47	3,87	14,40	4,26	16,32	4,65	18,22	5,04	18,98	5,20	20,11	5,44	21,99	5,87
		23	12,49	4,21	14,38	4,61	16,25	5,00	18,11	5,41	18,86	5,58	19,96	5,84	21,80	6,29
		25	12,51	4,45	14,37	4,85	16,22	5,25	18,05	5,67	18,78	5,85	19,87	6,12	21,67	6,60
		27	12,54	4,69	14,37	5,10	16,19	5,51	17,99	5,95	18,71	6,13	19,78	6,41	21,56	6,92
Nominal airflow	3700 m³/h	15	12,60	3,27	14,65	3,62	16,68	3,96	18,70	4,30	19,50	4,43	20,70	4,64	22,70	4,99
		19	12,59	3,67	14,58	4,02	16,55	4,37	18,52	4,72	19,30	4,86	20,46	5,08	22,40	5,45
		20	12,59	3,77	14,57	4,13	16,53	4,48	18,47	4,83	19,25	4,98	20,41	5,20	22,33	5,58
		23	12,60	4,10	14,53	4,46	16,45	4,82	18,36	5,19	19,12	5,34	20,25	5,57	22,12	5,97
		25	12,62	4,34	14,52	4,70	16,41	5,06	18,29	5,44	19,03	5,59	20,15	5,83	22,00	6,26
		27	12,64	4,58	14,51	4,95	16,37	5,32	18,22	5,70	18,96	5,86	20,05	6,11	21,87	6,55
Maximum airflow	4100 m³/h	15	12,62	3,14	14,70	3,47	16,76	3,80	18,81	4,11	19,63	4,24	20,85	4,43	22,87	4,76
		19	12,60	3,52	14,62	3,86	16,63	4,19	18,62	4,52	19,42	4,65	20,60	4,85	22,57	5,20
		20	12,60	3,63	14,61	3,97	16,60	4,30	18,58	4,63	19,37	4,76	20,54	4,97	22,50	5,32
		23	12,60	3,95	14,57	4,29	16,52	4,63	18,45	4,97	19,22	5,11	20,38	5,32	22,29	5,69
		25	12,61	4,18	14,55	4,52	16,47	4,86	18,38	5,21	19,14	5,35	20,27	5,57	22,15	5,96
		27	12,63	4,42	14,54	4,76	16,43	5,10	18,31	5,46	19,06	5,60	20,17	5,83	22,02	6,23

INDOOR FAN POWER INPUT (kW)			
Minimum airflow	0,31	Nominal airflow	0,38
Maximum airflow	0,44		
OUTDOOR FAN POWER INPUT (kW)			
Nominal airflow	1,28		

GC (kW) :	Gross cooling capacity	NH (kW) :	Net heating capacity	SC (kW) :	Sensible cooling capacity	AC (kW) :	Compressor absorbed power
------------------	------------------------	------------------	----------------------	------------------	---------------------------	------------------	---------------------------

COOLING CAPACITIES

Table 4.2a

CMC - CMH25 S			Air inlet temperature at condenser (dry bulb)																		
Mixed air temperature °C	Indoor wet bulb	Indoor dry bulb	20 °C			25 °C			30 °C			35 °C			40 °C			45 °C			
			GC	SC	AC	GC	SC	AC	GC	SC	AC	GC	SC	AC	GC	SC	AC	GC	SC	AC	
Minimum airflow	4250 m³/h	16	21	24,5	14,6	5,0	23,8	14,3	5,4	23,1	14,0	5,8	22,2	13,6	6,4	21,2	13,1	7,1	20,1	12,6	8,1
			24	24,5	18,2	5,0	23,9	17,9	5,4	23,2	17,4	5,8	22,3	16,9	6,4	21,3	16,4	7,1	20,2	15,7	8,1
			27	24,7	21,2	5,0	24,1	20,8	5,4	23,4	20,4	5,8	22,6	19,8	6,4	21,6	19,2	7,1	20,5	18,4	8,1
		19	24	26,7	14,3	5,1	26,0	14,0	5,5	25,2	13,7	5,9	24,2	13,3	6,5	23,1	12,9	7,2	21,9	12,4	8,2
			27	26,7	18,1	5,1	26,0	17,7	5,5	25,2	17,3	5,9	24,2	16,9	6,5	23,2	16,4	7,2	22,0	15,7	8,2
			30	26,9	21,1	5,1	26,2	20,8	5,5	25,4	20,4	6,0	24,4	19,8	6,5	23,4	19,2	7,2	22,2	18,5	8,2
		22	27	29,2	13,5	5,3	28,4	13,3	5,7	27,5	13,0	6,1	26,5	12,7	6,7	25,3	12,4	7,4	24,0	12,0	8,4
			30	29,1	17,5	5,3	28,4	17,2	5,7	27,5	16,8	6,1	26,4	16,4	6,7	25,3	16,0	7,4	24,0	15,4	8,4
			33	29,2	20,7	5,3	28,5	20,4	5,7	27,6	20,0	6,1	26,6	19,5	6,7	25,5	19,0	7,4	24,2	18,4	8,4
Nominal airflow	5000 m³/h	16	21	25,0	15,4	5,2	24,3	15,0	5,6	23,5	14,7	6,0	22,6	14,2	6,6	21,5	13,7	7,3	20,4	13,2	8,4
			24	25,1	19,2	5,2	24,4	18,8	5,6	23,7	18,4	6,0	22,8	17,8	6,6	21,7	17,2	7,4	20,6	16,5	8,4
			27	25,4	22,5	5,2	24,8	22,1	5,6	24,0	21,6	6,1	23,1	21,0	6,6	22,1	20,3	7,4	21,0	19,5	8,4
		19	24	27,2	15,1	5,3	26,5	14,8	5,7	25,6	14,5	6,2	24,6	14,1	6,7	23,4	13,6	7,5	22,2	13,1	8,5
			27	27,3	19,1	5,3	26,5	18,8	5,7	25,7	18,4	6,2	24,7	17,9	6,7	23,6	17,3	7,5	22,3	16,6	8,5
			30	27,5	22,5	5,4	26,8	22,1	5,7	26,0	21,7	6,2	25,0	21,1	6,8	23,9	20,4	7,5	22,7	19,7	8,6
		22	27	29,7	14,4	5,5	28,9	14,1	5,9	27,9	13,9	6,3	26,8	13,5	6,9	25,6	13,2	7,7	24,3	12,8	8,7
			30	29,7	18,6	5,5	28,9	18,3	5,9	27,9	18,0	6,4	26,9	17,5	6,9	25,7	17,0	7,7	24,4	16,5	8,8
			33	29,9	22,1	5,5	29,1	21,8	5,9	28,2	21,4	6,4	27,1	20,9	7,0	25,9	20,3	7,7	24,6	19,6	8,8
Maximum airflow	5500 m³/h	16	21	25,5	15,4	5,1	24,8	15,1	5,5	23,9	14,8	5,9	23,0	14,3	6,4	21,9	13,8	7,1	20,7	13,3	8,0
			24	25,6	19,5	5,1	25,0	19,1	5,5	24,2	18,7	5,9	23,2	18,1	6,4	22,2	17,5	7,1	21,0	16,8	8,0
			27	26,0	23,0	5,2	25,3	22,6	5,5	24,6	22,1	5,9	23,6	21,5	6,5	22,6	20,8	7,1	21,4	20,0	8,1
		19	24	27,7	15,2	5,3	26,9	14,9	5,6	26,0	14,6	6,0	25,0	14,2	6,6	23,8	13,8	7,3	22,5	13,3	8,2
			27	27,8	19,4	5,3	27,0	19,1	5,6	26,2	18,7	6,1	25,1	18,2	6,6	24,0	17,6	7,3	22,7	16,9	8,2
			30	28,1	23,0	5,3	27,4	22,6	5,7	26,5	22,2	6,1	25,5	21,6	6,6	24,4	20,9	7,3	23,1	20,2	8,3
		22	27	30,2	14,5	5,5	29,3	14,2	5,8	28,3	14,0	6,2	27,2	13,7	6,8	26,0	13,3	7,5	24,6	12,9	8,5
			30	30,2	18,9	5,5	29,4	18,6	5,8	28,4	18,3	6,3	27,3	17,9	6,8	26,1	17,4	7,5	24,8	16,8	8,5
			33	30,5	22,7	5,5	29,6	22,3	5,8	28,7	21,9	6,3	27,6	21,4	6,8	26,4	20,8	7,5	25,1	20,1	8,5

HEATING CAPACITIES

Table 4.2b

CMH/CSH+CIH 025 S			Air inlet temperature at condenser (dry bulb)													
Indoor Dry Bulb			-10 °C		-5 °C		0 °C		5 °C		7 °C		10 °C		15 °C	
			NH	AC	NH	AC	NH	AC	NH	AC	NH	AC	NH	AC	NH	AC
Minimum airflow	4250 m³/h	15	16,09	4,22	18,64	4,64	21,18	5,05	23,69	5,45	24,70	5,62	26,19	5,87	28,67	6,30
		18	16,07	4,58	18,58	5,00	21,07	5,42	23,55	5,85	24,53	6,02	26,00	6,28	28,44	6,74
		20	16,06	4,83	18,55	5,26	21,01	5,69	23,46	6,13	24,43	6,31	25,88	6,58	28,29	7,06
		23	16,07	5,25	18,51	5,69	20,93	6,13	23,33	6,59	24,29	6,78	25,72	7,07	28,08	7,58
		25	16,08	5,55	18,49	5,99	20,89	6,45	23,26	6,92	24,20	7,12	25,61	7,42	27,95	7,96
		27	16,10	5,87	18,48	6,32	20,85	6,79	23,19	7,28	24,12	7,48	25,52	7,80	27,82	8,37
Nominal airflow	5000 m³/h	15	16,52	4,24	19,12	4,61	21,71	4,97	24,27	5,33	25,29	5,48	26,82	5,70	29,34	6,08
		19	16,48	4,72	19,02	5,09	21,55	5,46	24,06	5,84	25,06	5,99	26,55	6,23	29,01	6,64
		20	16,47	4,84	19,00	5,22	21,51	5,59	24,01	5,97	25,00	6,13	26,48	6,37	28,94	6,80
		23	16,46	5,25	18,95	5,63	21,42	6,01	23,87	6,41	24,84	6,58	26,30	6,83	28,71	7,28
		25	16,46	5,55	18,92	5,93	21,36	6,31	23,78	6,72	24,75	6,90	26,18	7,16	28,57	7,63
		27	16,46	5,86	18,90	6,24	21,31	6,64	23,70	7,06	24,66	7,24	26,08	7,52	28,43	8,01
Maximum airflow	5500 m³/h	15	16,59	4,11	19,23	4,45	21,84	4,79	24,44	5,13	25,47	5,26	27,02	5,47	29,57	5,83
		19	16,53	4,57	19,11	4,91	21,67	5,26	24,21	5,61	25,22	5,75	26,73	5,97	29,23	6,36
		20	16,52	4,69	19,08	5,04	21,63	5,38	24,15	5,74	25,16	5,88	26,66	6,11	29,15	6,50
		23	16,50	5,09	19,02	5,43	21,52	5,78	24,00	6,15	24,99	6,30	26,47	6,54	28,91	6,95
		25	16,49	5,37	18,98	5,71	21,46	6,07	23,91	6,45	24,89	6,60	26,35	6,85	28,76	7,28
		27	16,49	5,67	18,95	6,01	21,40	6,38	23,82	6,76	24,79	6,92	26,23	7,18	28,62	7,63

INDOOR FAN POWER INPUT (kW)			
Minimum airflow	0,54	Nominal airflow	0,69
Maximum airflow		Maximum airflow	0,80
OUTDOOR FAN POWER INPUT (kW)			
Nominal airflow	1,80		

GC (kW) :	Gross cooling capacity	NH (kW) :	Net heating capacity	SC (kW) :	Sensible cooling capacity	AC (kW) :	Compressor absorbed power
------------------	------------------------	------------------	----------------------	------------------	---------------------------	------------------	---------------------------

COOLING CAPACITIES

Table 4.3a

CMC - CMH030 S			Air inlet temperature at condenser (dry bulb)																		
Mixed air temperature °C	Indoor wet bulb	Indoor dry bulb	20 °C			25 °C			30 °C			35 °C			40 °C			45 °C			
			GC	SC	AC	GC	SC	AC	GC	SC	AC	GC	SC	AC	GC	SC	AC	GC	SC	AC	
Minimum airflow	4650 m³/h	16	21	27,7	16,4	5,5	27,0	16,1	5,9	26,0	15,6	6,4	25,0	15,1	7,1	23,7	14,5	8,0	22,3	13,9	9,2
			24	27,8	20,1	5,5	27,1	19,7	5,9	26,2	19,2	6,5	25,1	18,7	7,1	23,9	18,0	8,0	22,5	17,2	9,2
			27	27,9	23,6	5,5	27,2	23,2	5,9	26,3	22,7	6,5	25,3	22,0	7,1	24,0	21,3	8,0	22,6	20,3	9,2
		19	24	30,2	16,2	5,6	29,4	15,8	6,1	28,4	15,4	6,6	27,2	14,9	7,2	25,9	14,4	8,1	24,4	13,8	9,3
			27	30,3	19,9	5,6	29,5	19,5	6,1	28,5	19,0	6,6	27,3	18,5	7,3	26,0	17,9	8,1	24,5	17,1	9,3
			30	30,4	23,3	5,6	29,6	23,0	6,1	28,6	22,5	6,6	27,5	21,9	7,3	26,2	21,2	8,1	24,7	20,3	9,4
		22	27	32,9	15,7	5,8	32,0	15,3	6,2	30,9	14,9	6,8	29,7	14,5	7,4	28,2	14,0	8,3	26,7	13,5	9,5
			30	33,0	19,4	5,8	32,1	19,0	6,2	31,0	18,6	6,8	29,8	18,1	7,4	28,4	17,6	8,3	26,8	16,9	9,5
			33	33,1	22,9	5,8	32,2	22,5	6,2	31,1	22,1	6,8	29,9	21,5	7,4	28,5	20,9	8,3	26,9	20,2	9,5
Nominal airflow	5450 m³/h	16	21	28,4	17,2	5,7	27,6	16,9	6,1	26,6	16,4	6,6	25,4	15,9	7,3	24,1	15,3	8,2	22,7	14,6	9,5
			24	28,5	21,4	5,7	27,7	21,0	6,1	26,7	20,5	6,7	25,6	19,9	7,3	24,3	19,1	8,2	22,8	18,3	9,5
			27	28,6	25,3	5,7	27,8	24,9	6,1	26,9	24,4	6,7	25,7	23,7	7,3	24,5	22,8	8,2	23,0	21,8	9,5
		19	24	30,9	16,9	5,8	30,0	16,5	6,3	29,0	16,1	6,8	27,7	15,6	7,5	26,3	15,1	8,4	24,8	14,5	9,6
			27	31,0	21,1	5,8	30,1	20,7	6,3	29,1	20,3	6,8	27,9	19,7	7,5	26,5	19,0	8,4	24,9	18,3	9,6
			30	31,1	25,1	5,8	30,2	24,7	6,3	29,2	24,2	6,8	28,0	23,6	7,5	26,6	22,8	8,4	25,1	21,9	9,7
		22	27	33,6	16,3	6,0	32,7	16,0	6,4	31,5	15,6	7,0	30,2	15,2	7,7	28,8	14,7	8,6	27,1	14,2	9,8
			30	33,7	20,6	6,0	32,8	20,3	6,4	31,6	19,8	7,0	30,3	19,3	7,7	28,9	18,8	8,6	27,3	18,1	9,9
			33	33,8	24,6	6,0	32,9	24,3	6,4	31,8	23,8	7,0	30,5	23,3	7,7	29,0	22,6	8,6	27,4	21,8	9,9
Maximum airflow	6000 m³/h	16	21	28,9	17,3	5,6	28,1	17,0	6,0	27,1	16,6	6,5	25,9	16,1	7,1	24,6	15,5	7,9	23,1	14,8	9,1
			24	29,0	21,9	5,6	28,2	21,5	6,0	27,2	21,0	6,5	26,1	20,4	7,1	24,8	19,6	7,9	23,3	18,8	9,1
			27	29,2	26,2	5,6	28,4	25,7	6,0	27,4	25,2	6,5	26,2	24,5	7,1	24,9	23,6	7,9	23,4	22,7	9,1
		19	24	31,5	16,9	5,7	30,6	16,6	6,1	29,5	16,2	6,6	28,2	15,7	7,3	26,8	15,2	8,1	25,2	14,6	9,3
			27	31,6	21,5	5,7	30,7	21,2	6,1	29,6	20,7	6,6	28,4	20,1	7,3	27,0	19,5	8,1	25,4	18,7	9,3
			30	31,7	25,9	5,7	30,8	25,5	6,1	29,8	25,0	6,7	28,5	24,4	7,3	27,1	23,6	8,1	25,6	22,6	9,3
		22	27	34,3	16,2	5,9	33,3	15,9	6,3	32,1	15,6	6,8	30,8	15,2	7,5	29,3	14,8	8,3	27,6	14,2	9,5
			30	34,4	20,9	5,9	33,4	20,6	6,3	32,2	20,2	6,8	30,9	19,7	7,5	29,4	19,1	8,3	27,7	18,5	9,5
			33	34,5	25,3	5,9	33,5	25,0	6,3	32,3	24,5	6,9	31,0	24,0	7,5	29,5	23,3	8,4	27,9	22,5	9,5

HEATING CAPACITIES

Table 4.3b

CMH/CSH+CIH 030 S			Air inlet temperature at condenser (dry bulb)													
Indoor Dry Bulb			-10 °C		-5 °C		0 °C		5 °C		7 °C		10 °C		15 °C	
			NH	AC	NH	AC	NH	AC	NH	AC	NH	AC	NH	AC	NH	AC
Minimum airflow	4650 m³/h	15	19,25	4,76	22,30	5,33	25,28	5,87	28,18	6,40	29,32	6,60	31,01	6,92	33,76	7,46
		18	19,19	5,19	22,16	5,76	25,06	6,31	27,89	6,86	29,00	7,08	30,64	7,41	33,32	7,98
		20	19,15	5,48	22,07	6,07	24,92	6,63	27,70	7,18	28,79	7,41	30,40	7,75	33,03	8,35
		23	19,09	5,96	21,94	6,55	24,71	7,12	27,42	7,71	28,48	7,94	30,04	8,31	32,60	8,94
		25	19,05	6,29	21,85	6,89	24,58	7,48	27,23	8,08	28,27	8,32	29,81	8,70	32,32	9,37
		27	19,02	6,63	21,77	7,24	24,44	7,85	27,05	8,47	28,07	8,72	29,58	9,12	32,03	9,82
Nominal airflow	5450 m³/h	15	19,68	4,73	22,82	5,25	25,88	5,74	28,87	6,22	30,04	6,41	31,78	6,70	34,62	7,19
		19	19,59	5,30	22,62	5,83	25,58	6,33	28,47	6,83	29,61	7,03	31,29	7,33	34,03	7,85
		20	19,56	5,45	22,57	5,98	25,51	6,48	28,37	6,98	29,50	7,19	31,17	7,50	33,88	8,03
		23	19,50	5,92	22,44	6,45	25,30	6,97	28,09	7,49	29,18	7,70	30,80	8,02	33,45	8,59
		25	19,46	6,26	22,35	6,79	25,16	7,31	27,90	7,84	28,97	8,06	30,56	8,40	33,16	8,98
		27	19,42	6,60	22,26	7,13	25,02	7,67	27,71	8,22	28,77	8,44	30,33	8,79	32,87	9,41
Maximum airflow	6000 m³/h	15	19,76	4,51	22,96	5,02	26,08	5,49	29,12	5,94	30,32	6,12	32,10	6,39	35,00	6,85
		19	19,66	5,07	22,75	5,57	25,78	6,05	28,72	6,51	29,88	6,70	31,60	6,98	34,40	7,47
		20	19,64	5,22	22,71	5,72	25,70	6,19	28,62	6,66	29,77	6,85	31,47	7,14	34,25	7,63
		23	19,57	5,67	22,56	6,17	25,48	6,66	28,33	7,14	29,45	7,34	31,11	7,64	33,81	8,16
		25	19,52	5,99	22,47	6,49	25,34	6,98	28,14	7,47	29,24	7,68	30,87	7,99	33,52	8,53
		27	19,49	6,33	22,38	6,82	25,20	7,32	27,95	7,83	29,03	8,03	30,63	8,36	33,23	8,92

INDOOR FAN POWER INPUT (kW)			
Minimum airflow	0,68	Nominal airflow	0,86
Maximum airflow	1		
OUTDOOR FAN POWER INPUT (kW)			
Nominal airflow	2,68		

GC (kW) :	Gross cooling capacity	NH (kW) :	Net heating capacity	SC (kW) :	Sensible cooling capacity	AC (kW) :	Compressor absorbed power
------------------	------------------------	------------------	----------------------	------------------	---------------------------	------------------	---------------------------

COOLING CAPACITIES

Table 4.4a

CMC - CMH035 S			Air inlet temperature at condenser (dry bulb)																		
Mixed air temperature °C	Indoor wet bulb	Indoor dry bulb	20 °C			25 °C			30 °C			35 °C			40 °C			45 °C			
			GC	SC	AC	GC	SC	AC	GC	SC	AC	GC	SC	AC	GC	SC	AC	GC	SC	AC	
Minimum airflow	6200 m³/h	16	21	36,1	21,9	7,9	35,1	21,5	8,5	34,0	20,9	9,2	32,6	20,3	10,0	31,1	19,6	11,2	29,3	18,7	12,8
			24	36,2	27,3	7,9	35,3	26,8	8,5	34,1	26,1	9,2	32,8	25,4	10,0	31,3	24,5	11,2	29,6	23,4	12,9
			27	36,5	31,8	8,0	35,6	31,3	8,5	34,5	30,6	9,2	33,2	29,7	10,1	31,7	28,7	11,3	30,0	27,5	12,9
		19	24	39,2	21,5	8,2	38,1	21,1	8,7	36,9	20,6	9,4	35,4	20,0	10,3	33,7	19,4	11,4	31,8	18,6	13,1
			27	39,2	27,1	8,2	38,2	26,6	8,7	36,9	26,0	9,4	35,5	25,3	10,3	33,8	24,5	11,5	32,0	23,5	13,1
			30	39,5	31,8	8,2	38,5	31,3	8,7	37,3	30,6	9,4	35,8	29,8	10,3	34,2	28,9	11,5	32,4	27,8	13,2
		22	27	42,8	20,3	8,4	41,6	19,9	9,0	40,2	19,6	9,7	38,6	19,1	10,6	36,8	18,6	11,7	34,8	18,0	13,4
			30	42,7	26,3	8,4	41,6	25,9	9,0	40,2	25,4	9,7	38,6	24,7	10,6	36,8	24,0	11,7	34,8	23,2	13,4
			33	42,9	31,2	8,4	41,7	30,8	9,0	40,4	30,2	9,7	38,8	29,5	10,6	37,1	28,6	11,8	35,1	27,6	13,4
Nominal airflow	7100 m³/h	16	21	36,6	22,8	8,2	35,6	22,3	8,8	34,4	21,7	9,5	33,1	21,1	10,3	31,5	20,3	11,5	29,7	19,4	13,2
			24	36,8	28,6	8,3	35,8	28,0	8,8	34,6	27,4	9,5	33,3	26,5	10,4	31,7	25,6	11,5	30,0	24,5	13,2
			27	37,1	33,6	8,3	36,2	33,0	8,9	35,1	32,3	9,6	33,8	31,3	10,4	32,2	30,3	11,6	30,5	29,0	13,3
		19	24	39,8	22,4	8,5	38,7	21,9	9,0	37,4	21,4	9,7	35,8	20,9	10,6	34,1	20,2	11,8	32,2	19,4	13,4
			27	39,9	28,5	8,5	38,8	28,0	9,0	37,5	27,4	9,7	36,0	26,6	10,6	34,3	25,7	11,8	32,4	24,7	13,5
			30	40,2	33,7	8,5	39,1	33,1	9,1	37,8	32,4	9,8	36,4	31,6	10,7	34,7	30,5	11,9	32,8	29,3	13,5
		22	27	43,4	21,2	8,7	42,1	20,9	9,3	40,7	20,5	10,0	39,1	20,0	10,9	37,2	19,5	12,1	35,2	18,8	13,7
			30	43,4	27,7	8,7	42,2	27,3	9,3	40,7	26,7	10,0	39,1	26,1	10,9	37,3	25,3	12,1	35,3	24,4	13,8
			33	43,6	33,2	8,7	42,4	32,7	9,3	41,0	32,1	10,0	39,4	31,3	10,9	37,6	30,4	12,1	35,6	29,3	13,8
Maximum airflow	8050 m³/h	16	21	37,9	22,8	7,8	36,9	22,4	8,2	35,7	21,8	8,7	34,2	21,2	9,4	32,6	20,5	10,3	30,7	19,6	11,5
			24	38,1	29,2	7,8	37,1	28,7	8,3	35,9	28,0	8,8	34,5	27,2	9,5	32,9	26,3	10,4	31,1	25,1	11,6
			27	38,6	34,8	7,9	37,6	34,2	8,3	36,4	33,5	8,9	35,0	32,5	9,6	33,4	31,4	10,5	31,7	30,1	11,7
		19	24	41,1	22,3	8,0	40,0	21,9	8,5	38,6	21,4	9,0	37,0	20,9	9,7	35,3	20,2	10,6	33,3	19,5	11,9
			27	41,2	29,1	8,0	40,1	28,6	8,5	38,8	27,9	9,1	37,2	27,2	9,8	35,5	26,3	10,7	33,6	25,3	11,9
			30	41,6	34,9	8,1	40,5	34,3	8,5	39,2	33,6	9,1	37,7	32,7	9,8	36,0	31,7	10,8	34,0	30,5	12,0
		22	27	44,7	21,0	8,3	43,4	20,7	8,8	42,0	20,4	9,3	40,3	20,0	10,0	38,4	19,4	11,0	36,3	18,8	12,3
			30	44,8	28,2	8,3	43,5	27,8	8,8	42,1	27,3	9,3	40,4	26,6	10,1	38,5	25,9	11,0	36,5	25,0	12,3
			33	45,0	34,2	8,3	43,8	33,7	8,8	42,4	33,1	9,4	40,7	32,3	10,1	38,9	31,4	11,1	36,8	30,3	12,4

HEATING CAPACITIES

Table 4.4b

CMH/CSH+CIH 035 S			Air inlet temperature at condenser (dry bulb)													
Indoor Dry Bulb			-10 °C		-5 °C		0 °C		5 °C		7 °C		10 °C		15 °C	
			NH	AC	NH	AC	NH	AC	NH	AC	NH	AC	NH	AC	NH	AC
Minimum airflow	6200 m³/h	15	23,49	6,21	27,16	6,91	30,77	7,58	34,32	8,23	35,72	8,48	37,81	8,87	41,24	9,53
		18	23,43	6,66	27,02	7,39	30,56	8,08	34,03	8,76	35,41	9,03	37,45	9,44	40,80	10,15
		20	23,39	6,97	26,93	7,71	30,42	8,42	33,84	9,13	35,19	9,41	37,20	9,85	40,51	10,59
		23	23,33	7,44	26,80	8,21	30,20	8,96	33,55	9,71	34,87	10,02	36,84	10,48	40,07	11,28
		25	23,28	7,77	26,70	8,56	30,06	9,34	33,36	10,12	34,66	10,44	36,59	10,93	39,77	11,77
		27	23,24	8,09	26,61	8,91	29,91	9,72	33,16	10,54	34,44	10,87	36,35	11,39	39,47	12,29
Nominal airflow	7100 m³/h	15	24,03	6,29	27,78	6,94	31,47	7,55	35,09	8,14	36,53	8,37	38,66	8,73	42,16	9,33
		19	23,96	6,91	27,60	7,58	31,19	8,22	34,71	8,85	36,11	9,10	38,18	9,48	41,58	10,14
		20	23,94	7,07	27,56	7,75	31,12	8,40	34,62	9,04	36,00	9,29	38,06	9,68	41,44	10,35
		23	23,87	7,56	27,42	8,26	30,90	8,94	34,33	9,61	35,68	9,89	37,69	10,30	41,00	11,02
		25	23,83	7,90	27,33	8,61	30,76	9,31	34,13	10,02	35,47	10,30	37,45	10,74	40,70	11,50
		27	23,79	8,24	27,23	8,97	30,61	9,70	33,94	10,43	35,25	10,73	37,20	11,19	40,40	11,99
Maximum airflow	8050 m³/h	15	24,04	5,95	27,87	6,56	31,63	7,12	35,34	7,67	36,81	7,89	38,99	8,21	42,58	8,76
		19	23,97	6,55	27,69	7,18	31,36	7,77	34,96	8,34	36,39	8,57	38,51	8,92	41,99	9,51
		20	23,95	6,71	27,65	7,34	31,29	7,93	34,87	8,52	36,28	8,75	38,39	9,10	41,85	9,70
		23	23,88	7,19	27,51	7,83	31,07	8,45	34,58	9,06	35,96	9,31	38,02	9,68	41,41	10,32
		25	23,84	7,51	27,42	8,17	30,93	8,80	34,39	9,44	35,75	9,69	37,78	10,08	41,12	10,76
		27	23,80	7,84	27,32	8,51	30,79	9,16	34,19	9,82	35,54	10,09	37,53	10,50	40,82	11,21

INDOOR FAN POWER INPUT (kW)			
Minimum airflow	0,82	Nominal airflow	0,99
Maximum airflow	1,20		
OUTDOOR FAN POWER INPUT (kW)			
Nominal airflow	2,13		

GC (kW) :	Gross cooling capacity	NH (kW) :	Net heating capacity	SC (kW) :	Sensible cooling capacity	AC (kW) :	Compressor absorbed power
------------------	------------------------	------------------	----------------------	------------------	---------------------------	------------------	---------------------------

COOLING CAPACITIES

Table 4.5a

CMC - CMH040 S			Air inlet temperature at condenser (dry bulb)																		
Mixed air temperature °C	Indoor wet bulb	Indoor dry bulb	20 °C			25 °C			30 °C			35 °C			40 °C			45 °C			
			GC	SC	AC	GC	SC	AC	GC	SC	AC	GC	SC	AC	GC	SC	AC	GC	SC	AC	
Minimum airflow	6950 m ³ /h	16	21	42,1	24,7	9,1	41,0	24,2	9,7	39,6	23,5	10,5	38,0	22,8	11,5	36,1	21,9	12,9	33,9	20,8	14,9
			24	42,1	30,5	9,1	41,1	29,9	9,8	39,7	29,2	10,5	38,1	28,3	11,6	36,2	27,2	13,0	34,1	25,9	15,0
			27	42,4	35,6	9,1	41,3	35,0	9,8	40,0	34,2	10,6	38,4	33,2	11,6	36,6	31,9	13,0	34,5	30,5	15,0
		19	24	45,8	24,2	9,4	44,5	23,7	10,0	43,0	23,1	10,8	41,2	22,4	11,8	39,1	21,6	13,2	36,8	20,6	15,2
			27	45,8	30,2	9,4	44,6	29,6	10,0	43,1	28,9	10,8	41,3	28,1	11,8	39,2	27,1	13,2	36,9	25,9	15,3
			30	46,0	35,4	9,4	44,8	34,8	10,0	43,3	34,0	10,8	41,6	33,1	11,9	39,5	31,9	13,3	37,2	30,6	15,3
		22	27	50,0	22,9	9,6	48,5	22,5	10,3	46,8	22,0	11,1	44,9	21,4	12,2	42,6	20,8	13,6	40,1	20,0	15,6
			30	49,9	29,2	9,6	48,5	28,7	10,3	46,8	28,1	11,1	44,9	27,4	12,2	42,7	26,5	13,6	40,2	25,5	15,6
			33	50,0	34,6	9,6	48,6	34,1	10,3	47,0	33,4	11,1	45,1	32,5	12,2	42,9	31,5	13,6	40,5	30,3	15,7
Nominal airflow	8150 m ³ /h	16	21	42,8	25,9	9,6	41,6	25,4	10,2	40,2	24,7	11,0	38,5	23,9	12,1	36,5	22,9	13,5	34,3	21,8	15,7
			24	43,0	32,3	9,6	41,8	31,6	10,2	40,4	30,8	11,1	38,7	29,8	12,1	36,8	28,7	13,6	34,6	27,3	15,7
			27	43,3	37,9	9,6	42,2	37,2	10,3	40,8	36,3	11,1	39,2	35,2	12,2	37,2	33,9	13,7	35,1	32,3	15,8
		19	24	46,6	25,5	9,8	45,2	24,9	10,5	43,6	24,3	11,3	41,7	23,6	12,4	39,6	22,7	13,9	37,2	21,7	16,0
			27	46,6	32,0	9,8	45,3	31,4	10,5	43,8	30,7	11,3	41,9	29,7	12,4	39,8	28,7	13,9	37,4	27,4	16,1
			30	46,9	37,8	9,9	45,7	37,1	10,5	44,1	36,3	11,4	42,3	35,2	12,5	40,2	34,0	13,9	37,9	32,5	16,1
		22	27	50,7	24,3	10,1	49,2	23,9	10,8	47,5	23,3	11,6	45,4	22,7	12,7	43,1	22,0	14,2	40,6	21,2	16,4
			30	50,7	31,2	10,1	49,3	30,6	10,8	47,5	30,0	11,6	45,5	29,2	12,7	43,3	28,2	14,2	40,7	27,1	16,4
			33	51,0	37,2	10,1	49,5	36,5	10,8	47,8	35,8	11,7	45,8	34,9	12,8	43,6	33,7	14,3	41,1	32,4	16,5
Maximum airflow	9050 m ³ /h	16	21	43,7	26,0	9,5	42,4	25,4	10,1	40,9	24,8	10,8	39,2	24,0	11,8	37,1	23,0	13,1	34,8	21,9	15,0
			24	43,9	32,8	9,5	42,7	32,1	10,1	41,2	31,3	10,9	39,5	30,3	11,8	37,5	29,1	13,2	35,2	27,7	15,1
			27	44,3	38,8	9,6	43,2	38,1	10,2	41,7	37,2	10,9	40,0	36,1	11,9	38,0	34,7	13,2	35,8	33,1	15,1
		19	24	47,4	25,5	9,7	46,0	25,0	10,4	44,4	24,4	11,1	42,4	23,6	12,1	40,2	22,8	13,5	37,8	21,8	15,4
			27	47,6	32,5	9,8	46,2	31,9	10,4	44,6	31,1	11,2	42,7	30,2	12,2	40,5	29,1	13,5	38,1	27,8	15,5
			30	47,9	38,7	9,8	46,6	38,0	10,4	45,0	37,2	11,2	43,1	36,1	12,2	41,0	34,9	13,6	38,6	33,3	15,5
		22	27	51,6	24,3	10,0	50,0	23,9	10,7	48,2	23,4	11,5	46,1	22,8	12,5	43,8	22,1	13,9	41,2	21,3	15,9
			30	51,7	31,6	10,1	50,2	31,1	10,7	48,4	30,4	11,5	46,3	29,6	12,5	44,0	28,7	13,9	41,4	27,6	15,9
			33	52,0	38,0	10,1	50,5	37,4	10,7	48,7	36,7	11,5	46,7	35,7	12,5	44,4	34,6	13,9	41,8	33,2	15,9

HEATING CAPACITIES

Table 4.5b

CMH/CSH+CIH 040 S			Air inlet temperature at condenser (dry bulb)													
Indoor Dry Bulb		-10 °C		-5 °C		0 °C		5 °C		7 °C		10 °C		15 °C		
		NH	AC	NH	AC	NH	AC	NH	AC	NH	AC	NH	AC	NH	AC	
Minimum airflow	6950 m ³ /h	15	27,37	6,96	31,63	7,78	35,81	8,56	39,92	9,32	41,55	9,62	43,97	10,07	47,95	10,84
		18	27,31	7,48	31,48	8,33	35,57	9,14	39,60	9,94	41,19	10,26	43,56	10,74	47,45	11,56
		20	27,27	7,84	31,38	8,71	35,41	9,54	39,38	10,37	40,95	10,70	43,28	11,21	47,11	12,07
		23	27,21	8,39	31,22	9,29	35,17	10,17	39,05	11,05	40,58	11,41	42,86	11,95	46,60	12,89
		25	27,16	8,77	31,12	9,70	35,00	10,61	38,82	11,53	40,33	11,90	42,57	12,47	46,26	13,47
		27	27,11	9,16	31,01	10,11	34,84	11,06	38,60	12,02	40,08	12,42	42,29	13,02	45,92	14,07
Nominal airflow	8150 m ³ /h	15	28,09	7,05	32,44	7,80	36,72	8,51	40,93	9,20	42,60	9,47	45,08	9,89	49,16	10,58
		19	28,01	7,76	32,24	8,54	36,40	9,28	40,50	10,02	42,12	10,31	44,53	10,75	48,49	11,51
		20	27,99	7,94	32,19	8,73	36,32	9,48	40,39	10,23	42,00	10,53	44,39	10,98	48,32	11,76
		23	27,92	8,50	32,04	9,32	36,08	10,11	40,06	10,89	41,63	11,21	43,97	11,70	47,82	12,53
		25	27,88	8,89	31,93	9,72	35,92	10,54	39,84	11,35	41,39	11,69	43,69	12,19	47,48	13,07
		27	27,83	9,28	31,83	10,13	35,76	10,98	39,62	11,83	41,14	12,18	43,41	12,71	47,13	13,64
Maximum airflow	9050 m ³ /h	15	28,36	6,91	32,79	7,61	37,14	8,28	41,43	8,92	43,13	9,18	45,66	9,56	49,81	10,20
		19	28,29	7,61	32,59	8,34	36,83	9,03	41,00	9,71	42,65	9,98	45,11	10,39	49,14	11,08
		20	28,27	7,79	32,54	8,52	36,75	9,22	40,90	9,91	42,53	10,19	44,97	10,61	48,98	11,32
		23	28,20	8,34	32,39	9,10	36,51	9,82	40,57	10,55	42,17	10,84	44,55	11,28	48,47	12,04
		25	28,16	8,72	32,29	9,49	36,35	10,24	40,35	10,99	41,93	11,29	44,27	11,75	48,13	12,55
		27	28,11	9,10	32,19	9,89	36,19	10,66	40,12	11,44	41,68	11,75	43,99	12,24	47,79	13,08

INDOOR FAN POWER INPUT (kW)																							
Minimum airflow				1,12				Nominal airflow				1,42				Maximum airflow				1,67			
OUTDOOR FAN POWER INPUT (kW)																							
Nominal airflow								2,05															

GC (kW) :	Gross cooling capacity	NH (kW) :	Net heating capacity	SC (kW) :	Sensible cooling capacity	AC (kW) :	Compressor absorbed power
------------------	------------------------	------------------	----------------------	------------------	---------------------------	------------------	---------------------------

COOLING CAPACITIES

Table 4.6a

CMC - CMH45 S			Air inlet temperature at condenser (dry bulb)																		
Mixed air temperature °C	Indoor wet bulb	Indoor dry bulb	20 °C			25 °C			30 °C			35 °C			40 °C			45 °C			
			GC	SC	AC	GC	SC	AC	GC	SC	AC	GC	SC	AC	GC	SC	AC	GC	SC	AC	
Minimum airflow	7950 m³/h	16	21	48,4	27,9	9,7	47,1	27,2	10,4	45,6	26,5	11,3	43,7	25,6	12,4	41,5	24,6	13,9	39,1	23,5	16,1
			24	48,4	34,5	9,7	47,2	33,8	10,4	45,6	33,0	11,3	43,8	31,9	12,4	41,7	30,7	13,9	39,3	29,3	16,1
			27	48,7	40,2	9,7	47,5	39,5	10,4	46,0	38,6	11,3	44,2	37,5	12,5	42,1	36,1	14,0	39,7	34,5	16,1
		19	24	52,8	27,2	10,0	51,3	26,7	10,7	49,5	26,0	11,6	47,5	25,2	12,7	45,1	24,3	14,2	42,5	23,3	16,4
			27	52,7	34,2	9,9	51,2	33,5	10,7	49,5	32,7	11,6	47,5	31,8	12,7	45,2	30,6	14,3	42,6	29,4	16,4
			30	52,9	40,1	10,0	51,5	39,4	10,7	49,8	38,5	11,6	47,8	37,4	12,8	45,5	36,1	14,3	43,0	34,6	16,4
		22	27	57,6	25,8	10,3	55,9	25,3	11,0	54,0	24,7	12,0	51,8	24,1	13,1	49,3	23,3	14,7	46,4	22,5	16,8
			30	57,4	33,1	10,3	55,8	32,5	11,0	53,9	31,8	11,9	51,7	30,9	13,1	49,2	30,0	14,7	46,4	28,8	16,8
			33	57,5	39,2	10,3	55,9	38,5	11,0	54,0	37,8	12,0	51,9	36,8	13,1	49,4	35,7	14,7	46,7	34,3	16,9
Nominal airflow	9400 m³/h	16	21	49,2	29,2	10,3	47,9	28,5	11,0	46,2	27,7	11,9	44,2	26,8	13,1	42,0	25,8	14,7	39,5	24,6	16,9
			24	49,4	36,4	10,3	48,0	35,6	11,0	46,4	34,7	12,0	44,5	33,6	13,1	42,3	32,3	14,7	39,8	30,8	16,9
			27	49,8	42,7	10,4	48,5	41,9	11,1	46,9	40,9	12,0	45,0	39,7	13,2	42,9	38,2	14,8	40,4	36,5	17,0
		19	24	53,6	28,7	10,6	52,0	28,0	11,3	50,2	27,3	12,2	48,0	26,5	13,4	45,6	25,6	15,0	42,9	24,5	17,3
			27	53,6	36,2	10,6	52,1	35,5	11,3	50,3	34,6	12,3	48,2	33,6	13,4	45,8	32,4	15,0	43,1	31,0	17,3
			30	54,0	42,7	10,6	52,5	41,9	11,4	50,7	40,9	12,3	48,6	39,8	13,5	46,3	38,4	15,1	43,6	36,8	17,4
		22	27	58,4	27,3	10,9	56,6	26,8	11,7	54,6	26,2	12,6	52,3	25,5	13,8	49,7	24,8	15,5	46,8	23,8	17,8
			30	58,3	35,2	10,9	56,6	34,6	11,7	54,7	33,8	12,6	52,4	32,9	13,9	49,8	31,9	15,5	47,0	30,7	17,8
			33	58,6	42,0	10,9	56,9	41,3	11,7	55,0	40,4	12,7	52,7	39,4	13,9	50,2	38,1	15,5	47,4	36,7	17,8
Maximum airflow	9750 m³/h	16	21	49,5	29,2	10,3	48,1	28,6	11,1	46,4	27,8	11,9	44,5	26,9	13,1	42,2	25,9	14,6	39,6	24,6	16,8
			24	49,7	36,6	10,4	48,3	35,8	11,1	46,7	34,9	12,0	44,7	33,8	13,1	42,5	32,5	14,6	40,0	31,0	16,8
			27	50,2	43,0	10,4	48,8	42,2	11,1	47,2	41,2	12,0	45,3	40,0	13,2	43,1	38,5	14,7	40,6	36,8	16,9
		19	24	53,8	28,7	10,6	52,2	28,1	11,3	50,4	27,4	12,3	48,2	26,6	13,4	45,8	25,7	15,0	43,1	24,6	17,2
			27	53,9	36,4	10,6	52,4	35,7	11,4	50,5	34,8	12,3	48,4	33,8	13,4	46,0	32,6	15,0	43,3	31,2	17,2
			30	54,3	43,0	10,7	52,8	42,3	11,4	51,0	41,3	12,3	48,9	40,1	13,5	46,5	38,7	15,1	43,9	37,1	17,3
		22	27	58,6	27,4	11,0	56,9	26,9	11,7	54,8	26,3	12,7	52,5	25,6	13,9	49,9	24,9	15,5	47,0	23,9	17,7
			30	58,6	35,5	11,0	56,9	34,8	11,7	54,9	34,1	12,7	52,6	33,2	13,9	50,0	32,1	15,5	47,1	30,9	17,8
			33	58,9	42,4	11,0	57,2	41,7	11,7	55,2	40,8	12,7	53,0	39,8	13,9	50,4	38,5	15,5	47,6	37,0	17,8

HEATING CAPACITIES

Table 4.6b

CMH/CSH+CIH 045 S		Air inlet temperature at condenser (dry bulb)														
Indoor Dry Bulb		-10 °C		-5 °C		0 °C		5 °C		7 °C		10 °C		15 °C		
		NH	AC	NH	AC	NH	AC	NH	AC	NH	AC	NH	AC	NH	AC	
Minimum airflow	7950 m³/h	15	31,98	7,76	37,01	8,74	41,93	9,69	46,74	10,64	48,63	11,03	51,43	11,62	56,00	12,65
		18	31,86	8,47	36,80	9,47	41,63	10,46	46,33	11,45	48,19	11,86	50,93	12,49	55,41	13,59
		20	31,79	8,97	36,67	9,99	41,43	11,01	46,07	12,04	47,90	12,47	50,60	13,13	55,02	14,29
		23	31,69	9,80	36,48	10,85	41,14	11,91	45,69	13,01	47,48	13,46	50,13	14,17	54,45	15,43
		25	31,64	10,39	36,36	11,47	40,96	12,57	45,45	13,71	47,21	14,19	49,82	14,93	54,07	16,27
	27	31,59	11,03	36,24	12,14	40,78	13,27	45,21	14,47	46,94	14,97	49,51	15,76	53,71	17,19	
Nominal airflow	9400 m³/h	15	33,16	7,80	38,33	8,67	43,39	9,51	48,33	10,35	50,27	10,69	53,15	11,22	57,86	12,13
		19	32,97	8,73	38,02	9,62	42,95	10,49	47,76	11,39	49,65	11,75	52,46	12,32	57,04	13,30
		20	32,93	8,98	37,94	9,88	42,84	10,76	47,62	11,67	49,50	12,04	52,29	12,61	56,83	13,62
		23	32,81	9,78	37,73	10,69	42,53	11,61	47,21	12,56	49,06	12,95	51,78	13,57	56,24	14,66
		25	32,74	10,36	37,59	11,28	42,33	12,22	46,95	13,21	48,77	13,62	51,46	14,26	55,85	15,41
	27	32,67	10,98	37,46	11,91	42,13	12,88	46,69	13,90	48,48	14,33	51,13	15,00	55,46	16,22	
Maximum airflow	9750 m³/h	15	33,35	7,76	38,55	8,60	43,64	9,42	48,61	10,24	50,57	10,57	53,47	11,08	58,21	11,96
		19	33,15	8,68	38,23	9,54	43,19	10,39	48,03	11,26	49,94	11,61	52,76	12,16	57,38	13,11
		20	33,11	8,93	38,15	9,80	43,08	10,65	47,89	11,53	49,79	11,89	52,59	12,45	57,17	13,42
		23	32,98	9,72	37,93	10,60	42,76	11,49	47,48	12,40	49,34	12,79	52,08	13,38	56,57	14,43
		25	32,90	10,29	37,79	11,18	42,56	12,09	47,21	13,04	49,04	13,43	51,75	14,05	56,17	15,16
	27	32,83	10,90	37,65	11,80	42,36	12,73	46,95	13,71	48,75	14,13	51,43	14,77	55,79	15,94	

INDOOR FAN POWER INPUT (kW)		
Minimum airflow	1,70	Nominal airflow 2,18
		Maximum airflow 2,30
OUTDOOR FAN POWER INPUT (kW)		
Nominal airflow	3,15	

GC (kW) :	Gross cooling capacity	NH (kW) :	Net heating capacity	SC (kW) :	Sensible cooling capacity	AC (kW) :	Compressor absorbed power
------------------	------------------------	------------------	----------------------	------------------	---------------------------	------------------	---------------------------

COOLING CAPACITIES

Table 4.7a

CMC - CMH055 D			Air inlet temperature at condenser (dry bulb)																		
Mixed air temperature °C	Indoor wet bulb	Indoor dry bulb	20 °C			25 °C			30 °C			35 °C			40 °C			45 °C			
			GC	SC	AC	GC	SC	AC	GC	SC	AC	GC	SC	AC	GC	SC	AC	GC	SC	AC	
Minimum airflow	9950 m³/h	16	21	57,6	34,1	12,1	56,0	33,3	13,0	54,0	32,4	14,1	51,7	31,3	15,5	49,1	30,0	17,4	46,1	28,6	20,1
			24	57,8	42,3	12,1	56,2	41,4	13,0	54,3	40,3	14,2	52,1	39,1	15,6	49,4	37,5	17,5	46,5	35,8	20,2
			27	58,3	49,3	12,1	56,7	48,4	13,1	54,9	47,2	14,2	52,7	45,8	15,6	50,1	44,1	17,5	47,2	42,1	20,2
		19	24	62,7	33,3	12,4	60,9	32,5	13,3	58,8	31,7	14,5	56,3	30,7	15,9	53,4	29,6	17,8	50,2	28,3	20,5
			27	62,8	41,9	12,4	61,0	41,0	13,3	58,9	40,1	14,5	56,5	38,9	15,9	53,7	37,5	17,8	50,5	35,9	20,5
			30	63,2	49,1	12,4	61,5	48,2	13,4	59,4	47,2	14,5	57,0	45,8	15,9	54,3	44,3	17,9	51,2	42,4	20,5
		22	27	68,4	31,4	12,8	66,4	30,8	13,7	64,1	30,1	14,9	61,4	29,3	16,3	58,4	28,4	18,2	55,0	27,3	20,9
			30	68,4	40,4	12,8	66,4	39,7	13,7	64,2	38,9	14,9	61,5	37,8	16,3	58,5	36,7	18,2	55,2	35,3	20,9
			33	68,6	48,0	12,8	66,7	47,2	13,7	64,5	46,3	14,9	61,9	45,1	16,3	59,0	43,7	18,3	55,7	42,1	21,0
Nominal airflow	11700 m³/h	16	21	58,9	35,7	12,4	57,3	34,9	13,3	55,2	34,0	14,4	52,8	32,8	15,8	50,1	31,5	17,8	47,0	30,0	20,5
			24	59,3	44,6	12,4	57,7	43,7	13,3	55,7	42,6	14,4	53,3	41,2	15,9	50,6	39,6	17,8	47,6	37,8	20,5
			27	60,0	52,3	12,4	58,4	51,4	13,4	56,5	50,1	14,5	54,2	48,6	16,0	51,5	46,8	17,9	48,5	44,7	20,6
		19	24	64,0	35,1	12,7	62,2	34,3	13,6	59,9	33,5	14,7	57,4	32,5	16,2	54,4	31,3	18,1	51,1	29,9	20,9
			27	64,3	44,4	12,7	62,5	43,5	13,6	60,3	42,5	14,8	57,8	41,2	16,2	54,9	39,7	18,2	51,6	38,0	20,9
			30	64,9	52,3	12,7	63,1	51,4	13,7	61,0	50,2	14,8	58,5	48,8	16,3	55,6	47,1	18,2	52,4	45,2	20,9
		22	27	69,7	33,4	13,0	67,6	32,8	14,0	65,2	32,1	15,1	62,5	31,2	16,6	59,4	30,3	18,6	55,9	29,1	21,3
			30	69,9	43,1	13,0	67,9	42,4	14,0	65,5	41,5	15,2	62,8	40,4	16,6	59,7	39,1	18,6	56,3	37,6	21,4
			33	70,3	51,4	13,1	68,4	50,6	14,0	66,0	49,6	15,2	63,4	48,3	16,7	60,3	46,8	18,7	56,9	45,1	21,4
Maximum airflow	12850 m³/h	16	21	59,9	36,0	12,3	58,2	35,2	13,1	56,1	34,2	14,2	53,7	33,1	15,6	50,9	31,8	17,4	47,7	30,3	20,0
			24	60,4	45,3	12,3	58,7	44,4	13,2	56,7	43,3	14,3	54,3	41,9	15,7	51,5	40,3	17,5	48,4	38,4	20,1
			27	61,2	53,5	12,4	59,6	52,5	13,3	57,6	51,3	14,4	55,2	49,7	15,7	52,5	47,9	17,6	49,5	45,8	20,1
		19	24	65,0	35,4	12,6	63,1	34,6	13,5	60,8	33,8	14,6	58,2	32,8	16,0	55,2	31,6	17,8	51,8	30,3	20,5
			27	65,4	45,1	12,6	63,5	44,2	13,5	61,3	43,2	14,6	58,7	41,9	16,0	55,8	40,5	17,9	52,5	38,7	20,5
			30	66,1	53,5	12,7	64,3	52,6	13,6	62,1	51,4	14,7	59,5	50,0	16,1	56,6	48,3	18,0	53,4	46,3	20,6
		22	27	70,7	33,7	13,0	68,6	33,1	13,9	66,1	32,4	15,0	63,3	31,6	16,4	60,1	30,6	18,3	56,6	29,5	21,0
			30	71,0	43,9	13,0	68,9	43,2	13,9	66,5	42,3	15,0	63,7	41,2	16,5	60,6	39,9	18,4	57,1	38,4	21,0
			33	71,5	52,6	13,0	69,5	51,8	14,0	67,1	50,8	15,1	64,4	49,5	16,5	61,3	48,0	18,4	57,9	46,2	21,1

HEATING CAPACITIES

Table 4.7b

CMH/CSH+CIH 055 D			Air inlet temperature at condenser (dry bulb)													
Indoor Dry Bulb			-10 °C		-5 °C		0 °C		5 °C		7 °C		10 °C		15 °C	
			NH	AC	NH	AC	NH	AC	NH	AC	NH	AC	NH	AC	NH	AC
Minimum airflow	9950 m³/h	15	38,56	10,34	44,70	11,50	50,70	12,60	56,57	13,67	58,88	14,11	62,31	14,76	67,90	15,87
		18	38,41	11,23	44,40	12,41	50,26	13,54	55,98	14,66	58,23	15,11	61,56	15,80	67,01	16,98
		20	38,33	11,86	44,21	13,05	49,97	14,20	55,59	15,35	57,80	15,82	61,07	16,53	66,42	17,77
		23	38,20	12,86	43,94	14,07	49,55	15,26	55,02	16,47	57,17	16,96	60,35	17,72	65,55	19,04
		25	38,13	13,56	43,77	14,79	49,27	16,01	54,64	17,26	56,75	17,77	59,88	18,56	64,98	19,96
	27	38,06	14,30	43,60	15,54	49,01	16,79	54,27	18,09	56,34	18,62	59,41	19,45	64,41	20,93	
Nominal airflow	11700 m³/h	15	39,15	9,95	45,48	11,02	51,67	12,03	57,72	13,01	60,11	13,40	63,64	13,99	69,43	14,99
		19	38,95	11,14	45,07	12,22	51,06	13,26	56,91	14,27	59,22	14,68	62,63	15,31	68,22	16,37
		20	38,90	11,46	44,97	12,54	50,91	13,58	56,72	14,61	59,00	15,02	62,39	15,66	67,92	16,74
		23	38,76	12,45	44,69	13,54	50,48	14,60	56,13	15,66	58,35	16,10	61,65	16,76	67,03	17,92
		25	38,68	13,14	44,50	14,24	50,19	15,31	55,75	16,41	57,93	16,86	61,16	17,55	66,45	18,75
	27	38,60	13,87	44,32	14,97	49,91	16,06	55,37	17,19	57,51	17,65	60,69	18,37	65,87	19,64	
Maximum airflow	12850 m³/h	15	39,29	9,59	45,73	10,61	52,05	11,57	58,22	12,50	60,65	12,86	64,26	13,42	70,17	14,34
		19	39,07	10,76	45,31	11,79	51,42	12,76	57,40	13,72	59,75	14,10	63,24	14,68	68,95	15,66
		20	39,02	11,08	45,21	12,10	51,27	13,08	57,20	14,04	59,53	14,43	62,99	15,01	68,64	16,02
		23	38,87	12,05	44,92	13,07	50,83	14,06	56,60	15,05	58,87	15,46	62,24	16,07	67,75	17,13
		25	38,78	12,74	44,72	13,76	50,54	14,76	56,21	15,77	58,44	16,18	61,75	16,82	67,16	17,92
	27	38,69	13,46	44,54	14,48	50,25	15,49	55,83	16,52	58,02	16,95	61,27	17,60	66,57	18,76	

INDOOR FAN POWER INPUT (kW)

Minimum airflow	1,45	Nominal airflow	1,76	Maximum airflow	2,00
-----------------	------	-----------------	------	-----------------	------

OUTDOOR FAN POWER INPUT (kW)

Nominal airflow	3,56
-----------------	------

GC (kW) :	Gross cooling capacity	NH (kW) :	Net heating capacity	SC (kW) :	Sensible cooling capacity	AC (kW) :	Compressor absorbed power
------------------	------------------------	------------------	----------------------	------------------	---------------------------	------------------	---------------------------

COOLING CAPACITIES

Table 4.8a

CMC - CMH070 D			Air inlet temperature at condenser (dry bulb)																		
Mixed air temperature °C	Indoor wet bulb	Indoor dry bulb	20 °C			25 °C			30 °C			35 °C			40 °C			45 °C			
			GC	SC	AC	GC	SC	AC	GC	SC	AC	GC	SC	AC	GC	SC	AC	GC	SC	AC	
Minimum airflow	12450 m ³ /h	16	21	71,6	41,9	16,0	69,8	40,9	17,2	67,6	39,8	18,6	64,9	38,5	20,4	61,8	37,1	22,8	58,2	35,4	26,2
			24	72,0	51,6	16,1	70,2	50,6	17,2	68,0	49,4	18,6	65,4	47,9	20,4	62,3	46,2	22,8	58,8	44,2	26,3
			27	72,5	60,8	16,1	70,7	59,8	17,3	68,5	58,5	18,7	65,9	56,9	20,5	62,8	55,0	22,9	59,3	52,6	26,4
		19	24	77,8	41,1	16,5	75,8	40,1	17,6	73,3	39,1	19,0	70,4	37,9	20,9	67,0	36,5	23,3	63,2	34,9	26,8
			27	78,2	50,8	16,5	76,2	49,9	17,7	73,7	48,7	19,1	70,8	47,3	20,9	67,5	45,7	23,4	63,8	43,8	26,9
			30	78,7	60,0	16,6	76,6	59,1	17,7	74,2	57,8	19,1	71,3	56,3	21,0	68,0	54,5	23,4	64,3	52,4	26,9
		22	27	84,6	39,8	17,0	82,3	38,9	18,1	79,6	37,9	19,6	76,4	36,8	21,4	72,9	35,6	23,9	68,8	34,2	27,4
			30	85,0	49,6	17,0	82,8	48,7	18,2	80,0	47,6	19,6	76,9	46,3	21,4	73,3	44,9	23,9	69,4	43,2	27,4
			33	85,4	58,8	17,0	83,2	57,9	18,2	80,5	56,7	19,6	77,4	55,4	21,5	73,9	53,7	24,0	69,9	51,8	27,5
Nominal airflow	14650 m ³ /h	16	21	73,4	43,4	16,3	71,5	42,4	17,4	69,1	41,4	18,7	66,3	40,1	20,5	63,0	38,6	22,8	59,4	36,8	26,1
			24	73,9	54,4	16,4	71,9	53,4	17,5	69,6	52,2	18,8	66,8	50,7	20,5	63,6	48,9	22,8	59,9	46,7	26,2
			27	74,3	65,0	16,4	72,4	64,0	17,5	70,1	62,6	18,9	67,3	60,9	20,6	64,1	58,8	22,9	60,5	56,3	26,3
		19	24	79,8	42,3	16,8	77,6	41,4	17,9	74,9	40,4	19,3	71,9	39,2	21,0	68,4	37,9	23,4	64,5	36,3	26,8
			27	80,2	53,5	16,8	78,0	52,6	17,9	75,4	51,4	19,3	72,4	50,0	21,1	68,9	48,3	23,5	65,0	46,4	26,8
			30	80,6	64,3	16,9	78,5	63,2	18,0	75,9	62,0	19,4	72,9	60,4	21,1	69,5	58,4	23,5	65,6	56,1	26,9
		22	27	86,7	40,7	17,3	84,3	39,9	18,4	81,4	39,0	19,8	78,1	37,9	21,6	74,4	36,7	24,0	70,3	35,4	27,5
			30	87,1	52,1	17,3	84,7	51,2	18,4	81,9	50,1	19,9	78,6	48,9	21,7	74,9	47,4	24,1	70,8	45,7	27,5
			33	87,5	62,9	17,3	85,1	62,0	18,5	82,3	60,8	19,9	79,1	59,4	21,7	75,4	57,6	24,1	71,3	55,6	27,6
Maximum airflow	15090 m ³ /h	16	21	74,1	43,4	16,0	72,1	42,5	17,0	69,7	41,4	18,3	66,9	40,1	19,9	63,6	38,7	22,0	59,9	36,9	25,1
			24	74,5	54,7	16,1	72,6	53,8	17,1	70,2	52,5	18,3	67,4	51,0	20,0	64,1	49,2	22,1	60,5	47,1	25,2
			27	75,0	65,7	16,1	73,1	64,6	17,1	70,7	63,3	18,4	67,9	61,6	20,0	64,7	59,5	22,2	61,0	56,9	25,3
		19	24	80,5	42,2	16,5	78,2	41,3	17,5	75,6	40,3	18,8	72,5	39,2	20,5	69,0	37,9	22,7	65,1	36,3	25,8
			27	80,9	53,8	16,5	78,7	52,8	17,6	76,1	51,7	18,9	73,0	50,3	20,5	69,5	48,6	22,8	65,6	46,7	25,9
			30	81,3	64,8	16,6	79,1	63,8	17,6	76,5	62,6	18,9	73,5	61,0	20,6	70,1	59,0	22,8	66,2	56,7	26,0
		22	27	87,4	40,5	17,0	85,0	39,7	18,1	82,1	38,8	19,4	78,8	37,8	21,1	75,0	36,6	23,4	70,9	35,3	26,6
			30	87,8	52,2	17,0	85,4	51,3	18,1	82,5	50,3	19,5	79,3	49,1	21,2	75,5	47,6	23,4	71,4	45,9	26,6
			33	88,3	63,3	17,1	85,9	62,4	18,2	83,0	61,3	19,5	79,7	59,9	21,2	76,1	58,1	23,5	71,9	56,0	26,7

HEATING CAPACITIES

Table 4.8b

CMH/CSH+CIH 070 D			Air inlet temperature at condenser (dry bulb)													
Indoor Dry Bulb			-10 °C		-5 °C		0 °C		5 °C		7 °C		10 °C		15 °C	
Minimum airflow	Indoor wet bulb		NH	AC	NH	AC	NH	AC	NH	AC	NH	AC	NH	AC	NH	AC
Minimum airflow	12450 m ³ /h	15	45,12	12,11	52,17	13,52	59,10	14,86	65,93	16,17	68,64	16,69	72,66	17,47	79,29	18,79
		18	45,04	13,00	51,94	14,46	58,73	15,86	65,42	17,23	68,07	17,78	72,01	18,62	78,49	20,03
		20	44,98	13,62	51,78	15,11	58,48	16,55	65,08	17,98	67,69	18,55	71,57	19,42	77,96	20,91
		23	44,88	14,56	51,54	16,12	58,10	17,64	64,56	19,15	67,11	19,77	70,91	20,70	77,15	22,32
		25	44,81	15,22	51,38	16,82	57,85	18,39	64,21	19,98	66,72	20,62	70,46	21,61	76,61	23,32
		27	44,75	15,88	51,22	17,53	57,59	19,17	63,85	20,83	66,33	21,51	70,02	22,55	76,07	24,37
Nominal airflow	14650 m ³ /h	15	46,36	12,15	53,57	13,42	60,68	14,63	67,68	15,80	70,45	16,26	74,58	16,96	81,37	18,14
		19	46,24	13,39	53,26	14,71	60,18	15,98	67,00	17,22	69,69	17,72	73,70	18,47	80,31	19,75
		20	46,21	13,71	53,19	15,05	60,06	16,33	66,82	17,59	69,50	18,10	73,48	18,87	80,04	20,18
		23	46,11	14,70	52,95	16,08	59,68	17,42	66,30	18,76	68,92	19,30	72,82	20,12	79,24	21,53
		25	46,05	15,38	52,79	16,79	59,42	18,18	65,95	19,57	68,53	20,13	72,37	21,00	78,70	22,49
		27	45,98	16,07	52,62	17,53	59,16	18,96	65,60	20,41	68,14	21,00	71,93	21,91	78,15	23,49
Maximum airflow	15090 m ³ /h	15	46,37	11,97	53,62	13,22	60,76	14,41	67,80	15,56	70,58	16,01	74,73	16,70	81,56	17,85
		19	46,26	13,20	53,31	14,50	60,26	15,74	67,11	16,96	69,82	17,45	73,85	18,18	80,49	19,43
		20	46,23	13,52	53,23	14,83	60,14	16,09	66,94	17,33	69,63	17,82	73,63	18,58	80,23	19,86
		23	46,13	14,51	53,00	15,86	59,76	17,17	66,42	18,47	69,05	19,00	72,97	19,80	79,42	21,18
		25	46,06	15,18	52,83	16,56	59,50	17,92	66,07	19,27	68,66	19,82	72,53	20,66	78,88	22,11
		27	45,99	15,87	52,67	17,29	59,24	18,69	65,71	20,10	68,27	20,68	72,08	21,56	78,34	23,10

INDOOR FAN POWER INPUT (kW)			
Minimum airflow	2,32	Nominal airflow	2,88
		Maximum airflow	3
OUTDOOR FAN POWER INPUT (kW)			
Nominal airflow		3,84	

GC (kW) :	Gross cooling capacity	NH (kW) :	Net heating capacity	SC (kW) :	Sensible cooling capacity	AC (kW) :	Compressor absorbed power
------------------	------------------------	------------------	----------------------	------------------	---------------------------	------------------	---------------------------

COOLING CAPACITIES

Table 4.9a

CMC - CMH085 D			Air inlet temperature at condenser (dry bulb)																		
Mixed air temperature °C	Indoor wet bulb	Indoor dry bulb	20 °C			25 °C			30 °C			35 °C			40 °C			45 °C			
			GC	SC	AC	GC	SC	AC	GC	SC	AC	GC	SC	AC	GC	SC	AC	GC	SC	AC	
Minimum airflow	14000 m³/h	16	21	86,8	50,5	18,2	84,6	49,4	19,5	81,8	48,1	21,1	78,5	46,6	23,2	74,7	44,8	26,1	70,3	42,7	30,3
			24	87,0	63,1	18,2	84,9	61,9	19,5	82,2	60,4	21,1	78,9	58,5	23,2	75,1	56,3	26,2	70,8	53,7	30,4
			27	87,8	73,7	18,2	85,7	72,4	19,6	83,1	70,7	21,2	79,9	68,7	23,4	76,2	66,2	26,3	71,9	63,2	30,5
		19	24	94,4	49,3	18,7	91,9	48,3	20,0	88,8	47,1	21,6	85,2	45,7	23,8	81,0	44,1	26,7	76,3	42,2	30,9
			27	94,5	62,5	18,7	92,0	61,4	20,0	89,0	59,9	21,6	85,4	58,2	23,8	81,3	56,1	26,7	76,7	53,7	31,0
			30	95,1	73,4	18,7	92,7	72,1	20,0	89,7	70,6	21,7	86,2	68,6	23,9	82,2	66,3	26,8	77,6	63,5	31,1
		22	27	103,0	46,4	19,3	100,1	45,6	20,6	96,7	44,6	22,3	92,8	43,5	24,4	88,3	42,2	27,4	83,3	40,6	31,7
			30	102,8	60,4	19,3	100,1	59,3	20,6	96,7	58,1	22,3	92,9	56,6	24,5	88,4	54,8	27,5	83,5	52,7	31,8
			33	103,3	71,8	19,3	100,5	70,6	20,6	97,3	69,2	22,3	93,5	67,5	24,5	89,1	65,4	27,5	84,2	62,9	31,9
Nominal airflow	16250 m³/h	16	21	88,5	52,4	18,7	86,2	51,3	20,0	83,3	49,9	21,6	79,8	48,3	23,7	75,9	46,5	26,5	71,3	44,3	30,8
			24	89,1	66,0	18,7	86,8	64,7	20,0	83,9	63,1	21,6	80,6	61,1	23,7	76,6	58,8	26,6	72,2	56,0	30,9
			27	90,1	77,5	18,8	87,9	76,2	20,1	85,1	74,4	21,8	81,8	72,2	23,9	77,9	69,6	26,8	73,5	66,5	31,0
		19	24	96,1	51,4	19,2	93,4	50,3	20,5	90,2	49,1	22,1	86,5	47,7	24,3	82,2	46,0	27,2	77,3	44,0	31,5
			27	96,5	65,6	19,2	93,8	64,4	20,5	90,7	62,9	22,2	87,0	61,0	24,3	82,8	58,9	27,3	78,0	56,3	31,6
			30	97,4	77,5	19,3	94,8	76,2	20,6	91,7	74,5	22,3	88,1	72,4	24,5	83,9	69,9	27,4	79,2	67,0	31,7
		22	27	104,6	48,8	19,8	101,6	47,9	21,2	98,1	46,9	22,8	94,0	45,7	25,0	89,4	44,3	28,0	84,2	42,7	32,4
			30	104,8	63,7	19,8	101,9	62,6	21,2	98,4	61,3	22,9	94,4	59,7	25,1	89,8	57,8	28,1	84,7	55,6	32,5
			33	105,5	76,2	19,9	102,6	74,9	21,2	99,2	73,4	23,0	95,3	71,6	25,2	90,8	69,3	28,2	85,8	66,7	32,6
Maximum airflow	16725 m³/h	16	21	89,3	52,6	18,4	86,9	51,5	19,7	83,9	50,2	21,2	80,5	48,6	23,2	76,5	46,7	25,9	71,9	44,5	29,8
			24	89,8	66,5	18,5	87,5	65,2	19,7	84,6	63,6	21,3	81,2	61,6	23,2	77,3	59,3	26,0	72,8	56,5	29,9
			27	91,0	78,3	18,6	88,7	76,9	19,8	85,9	75,2	21,4	82,6	73,0	23,4	78,7	70,3	26,1	74,2	67,2	30,0
		19	24	96,8	51,6	19,0	94,1	50,6	20,2	90,9	49,4	21,8	87,1	48,0	23,8	82,7	46,3	26,6	77,9	44,3	30,6
			27	97,2	66,1	19,0	94,6	64,9	20,3	91,4	63,4	21,8	87,7	61,5	23,9	83,4	59,4	26,7	78,6	56,8	30,7
			30	98,2	78,3	19,1	95,6	76,9	20,4	92,5	75,3	21,9	88,8	73,2	24,0	84,6	70,7	26,8	79,9	67,7	30,8
		22	27	105,3	49,0	19,6	102,3	48,2	20,9	98,7	47,2	22,5	94,6	46,0	24,6	90,0	44,6	27,5	84,8	43,0	31,6
			30	105,5	64,2	19,6	102,6	63,1	20,9	99,1	61,8	22,5	95,1	60,2	24,7	90,5	58,3	27,5	85,3	56,1	31,7
			33	106,3	76,9	19,7	103,4	75,7	21,0	100,0	74,2	22,6	96,0	72,3	24,7	91,5	70,1	27,6	86,4	67,4	31,8

HEATING CAPACITIES

Table 4.9b

CMH/CSH+CIH 085 D			Air inlet temperature at condenser (dry bulb)													
Indoor Dry Bulb			-10 °C		-5 °C		0 °C		5 °C		7 °C		10 °C		15 °C	
			NH	AC	NH	AC	NH	AC	NH	AC	NH	AC	NH	AC	NH	AC
Minimum airflow	14000 m³/h	15	52,67	13,52	60,81	15,06	68,87	16,54	76,87	17,98	80,05	18,56	84,80	19,42	92,66	20,89
		18	52,61	14,55	60,59	16,15	68,50	17,70	76,35	19,22	79,47	19,83	84,12	20,75	91,83	22,33
		20	52,57	15,26	60,45	16,91	68,26	18,50	76,00	20,08	79,07	20,72	83,67	21,69	91,27	23,34
		23	52,50	16,36	60,22	18,08	67,88	19,76	75,46	21,45	78,48	22,13	82,98	23,17	90,43	24,97
		25	52,45	17,11	60,07	18,88	67,62	20,63	75,10	22,40	78,08	23,12	82,52	24,22	89,86	26,13
Nominal airflow	16250 m³/h	15	54,01	13,53	62,32	14,93	70,55	16,27	78,72	17,57	81,97	18,09	86,82	18,87	94,85	20,19
		19	53,94	14,96	62,04	16,42	70,07	17,83	78,03	19,22	81,19	19,78	85,92	20,62	93,74	22,07
		20	53,92	15,33	61,97	16,81	69,95	18,23	77,86	19,65	81,00	20,22	85,70	21,09	93,47	22,56
		23	53,85	16,47	61,75	18,00	69,57	19,49	77,33	21,00	80,41	21,60	85,01	22,53	92,63	24,13
		25	53,81	17,24	61,60	18,82	69,32	20,37	76,97	21,93	80,01	22,57	84,55	23,55	92,07	25,23
Maximum airflow	16725 m³/h	15	54,12	13,40	62,46	14,78	70,74	16,09	78,94	17,36	82,20	17,87	87,07	18,64	95,14	19,93
		19	54,05	14,83	62,19	16,26	70,25	17,64	78,25	19,00	81,43	19,55	86,18	20,37	94,03	21,78
		20	54,03	15,20	62,12	16,65	70,13	18,04	78,08	19,43	81,23	19,98	85,95	20,83	93,76	22,27
		23	53,97	16,33	61,90	17,83	69,76	19,29	77,55	20,76	80,64	21,35	85,27	22,26	92,92	23,81
		25	53,92	17,10	61,75	18,64	69,50	20,16	77,19	21,69	80,25	22,31	84,81	23,26	92,36	24,90
		27	53,87	17,89	61,59	19,48	69,25	21,05	76,83	22,65	79,85	23,30	84,35	24,30	91,80	26,04

INDOOR FAN POWER INPUT (kW)

Minimum airflow	3,28	Nominal airflow	4	Maximum airflow	4,16
-----------------	------	-----------------	---	-----------------	------

OUTDOOR FAN POWER INPUT (kW)

Nominal airflow	4,20
-----------------	------

GC (kW) :	Gross cooling capacity	NH (kW) :	Net heating capacity	SC (kW) :	Sensible cooling capacity	AC (kW) :	Compressor absorbed power
------------------	------------------------	------------------	----------------------	------------------	---------------------------	------------------	---------------------------

COOLING CAPACITIES

Table 4.10a

CMC - CMH100 D			Air inlet temperature at condenser (dry bulb)																		
Mixed air temperature °C	Indoor wet bulb	Indoor dry bulb	20 °C			25 °C			30 °C			35 °C			40 °C			45 °C			
			GC	SC	AC	GC	SC	AC	GC	SC	AC	GC	SC	AC	GC	SC	AC	GC	SC	AC	
Minimum airflow	17350 m ³ /h	16	21	103,7	60,6	23,5	101,0	59,3	25,2	97,6	57,7	27,3	93,6	55,9	30,1	88,9	53,7	33,9	83,6	51,2	39,5
			24	104,1	74,5	23,5	101,4	73,2	25,2	98,1	71,5	27,4	94,1	69,4	30,1	89,4	67,0	33,9	84,1	64,0	39,5
			27	104,3	88,1	23,5	101,6	86,9	25,2	98,3	85,1	27,4	94,3	82,9	30,1	89,6	80,1	34,0	84,3	76,7	39,6
		19	24	112,8	59,4	24,1	109,7	58,0	25,8	106,0	56,5	28,0	101,7	54,7	30,8	96,6	52,7	34,6	91,0	50,4	40,3
			27	113,3	73,2	24,2	110,3	71,9	25,9	106,6	70,3	28,1	102,2	68,3	30,9	97,2	66,0	34,7	91,6	63,3	40,4
			30	113,6	86,8	24,2	110,6	85,5	25,9	106,9	83,9	28,1	102,5	81,8	30,9	97,5	79,2	34,8	91,9	76,0	40,4
		22	27	122,4	58,0	24,8	119,0	56,6	26,6	115,0	55,0	28,8	110,3	53,4	31,7	104,9	51,5	35,6	98,9	49,4	41,4
			30	123,1	71,5	24,9	119,7	70,2	26,7	115,6	68,6	28,9	110,9	66,8	31,8	105,6	64,7	35,7	99,6	62,2	41,5
			33	123,4	84,9	24,9	120,0	83,7	26,7	116,0	82,1	28,9	111,3	80,2	31,8	106,0	77,8	35,8	100,0	75,0	41,6
Nominal airflow	20400 m ³ /h	16	21	106,7	62,8	23,5	103,8	61,4	25,2	100,2	59,9	27,2	96,0	58,0	29,8	91,1	55,8	33,4	85,6	53,3	38,8
			24	107,2	78,5	23,6	104,3	77,1	25,2	100,8	75,4	27,2	96,6	73,3	29,9	91,7	70,6	33,5	86,2	67,5	38,8
			27	107,5	94,1	23,6	104,6	92,7	25,2	101,1	90,8	27,3	96,9	88,4	29,9	92,0	85,3	33,5	86,5	81,6	38,8
		19	24	115,9	61,3	24,2	112,7	59,9	25,9	108,8	58,4	28,0	104,2	56,6	30,7	99,0	54,6	34,4	93,1	52,3	39,8
			27	116,6	77,1	24,3	113,3	75,7	25,9	109,4	74,0	28,0	104,9	72,0	30,8	99,7	69,6	34,5	93,8	66,7	39,9
			30	116,9	92,7	24,3	113,7	91,3	26,0	109,8	89,5	28,1	105,3	87,3	30,8	100,1	84,5	34,5	94,2	81,1	39,9
		22	27	125,7	59,5	25,0	122,1	58,1	26,7	117,9	56,7	28,9	113,0	55,0	31,7	107,4	53,2	35,5	101,2	51,1	41,1
			30	126,4	75,1	25,0	122,9	73,8	26,8	118,6	72,2	28,9	113,7	70,4	31,8	108,2	68,2	35,6	101,9	65,6	41,2
			33	126,9	90,7	25,1	123,3	89,4	26,8	119,1	87,7	29,0	114,2	85,7	31,8	108,7	83,2	35,7	102,5	80,1	41,2
Maximum airflow	22450 m ³ /h	16	21	110,0	62,4	22,0	107,0	61,2	23,4	103,3	59,7	25,1	98,9	57,9	27,2	93,9	55,8	30,1	88,3	53,4	34,2
			24	110,6	79,6	22,1	107,6	78,3	23,4	103,9	76,6	25,1	99,6	74,5	27,3	94,6	72,0	30,2	88,9	68,9	34,3
			27	111,0	96,7	22,1	107,9	95,3	23,5	104,3	93,5	25,2	100,0	91,0	27,3	95,0	88,0	30,2	89,3	84,3	34,3
		19	24	119,4	60,4	22,8	116,0	59,1	24,2	112,0	57,7	26,0	107,3	56,1	28,2	101,9	54,2	31,2	95,9	52,0	35,5
			27	120,1	77,7	22,8	116,7	76,4	24,3	112,7	74,8	26,0	108,0	72,9	28,3	102,7	70,6	31,3	96,7	67,8	35,6
			30	120,5	94,9	22,9	117,1	93,6	24,3	113,1	91,8	26,1	108,5	89,6	28,3	103,1	86,8	31,4	97,1	83,5	35,6
		22	27	129,2	58,0	23,6	125,5	56,8	25,1	121,1	55,5	27,0	116,1	54,0	29,4	110,4	52,3	32,5	104,0	50,4	37,0
			30	130,0	75,3	23,7	126,3	74,0	25,2	122,0	72,6	27,1	116,9	70,8	29,4	111,2	68,8	32,6	104,9	66,3	37,1
			33	130,5	92,1	23,7	126,8	90,8	25,2	122,5	89,3	27,1	117,5	87,3	29,5	111,8	84,8	32,7	105,4	81,8	37,2

HEATING CAPACITIES

Table 4.10b

CSH+CIH 100 D			Air inlet temperature at condenser (dry bulb)													
Indoor Dry Bulb			-10 °C		-5 °C		0 °C		5 °C		7 °C		10 °C		15 °C	
			NH	AC	NH	AC	NH	AC	NH	AC	NH	AC	NH	AC	NH	AC
Minimum airflow	17350 m ³ /h	15	65,59	17,56	75,90	19,47	86,10	21,30	96,19	23,10	100,19	23,81	106,17	24,90	116,04	26,75
		18	65,50	18,92	75,61	20,89	85,61	22,79	95,50	24,68	99,43	25,44	105,29	26,59	114,96	28,57
		20	65,44	19,86	75,42	21,87	85,29	23,83	95,05	25,79	98,93	26,58	104,71	27,79	114,25	29,86
		23	65,37	21,34	75,15	23,42	84,82	25,48	94,39	27,55	98,18	28,40	103,84	29,69	113,19	31,94
		25	65,33	22,35	74,98	24,50	84,52	26,63	93,95	28,79	97,69	29,68	103,27	31,04	112,48	33,42
		27	65,29	23,40	74,81	25,61	84,21	27,82	93,51	30,09	97,20	31,02	102,70	32,46	111,78	34,98
Nominal airflow	20400 m ³ /h	15	66,95	17,42	77,48	19,15	87,89	20,80	98,19	22,42	102,28	23,07	108,38	24,05	118,47	25,70
		19	66,82	19,31	77,08	21,09	87,23	22,81	97,27	24,53	101,25	25,22	107,20	26,27	117,02	28,07
		20	66,79	19,80	76,99	21,60	87,07	23,34	97,04	25,08	101,00	25,79	106,90	26,86	116,66	28,71
		23	66,71	21,33	76,70	23,17	86,59	24,99	96,36	26,82	100,24	27,57	106,03	28,72	115,59	30,70
		25	66,66	22,38	76,52	24,27	86,27	26,14	95,92	28,05	99,74	28,83	105,45	30,03	114,88	32,12
		27	66,61	23,46	76,34	25,40	85,96	27,33	95,48	29,32	99,25	30,14	104,88	31,40	114,17	33,61
Maximum airflow	22450 m ³ /h	15	66,62	16,20	77,28	17,86	87,84	19,43	98,28	20,97	102,43	21,58	108,62	22,50	118,84	24,05
		19	66,48	18,00	76,88	19,70	87,17	21,34	97,35	22,95	101,39	23,60	107,42	24,58	117,39	26,25
		20	66,45	18,47	76,78	20,18	87,01	21,83	97,12	23,47	101,14	24,13	107,13	25,13	117,03	26,84
		23	66,36	19,93	76,49	21,68	86,52	23,39	96,44	25,10	100,38	25,80	106,25	26,86	115,95	28,68
		25	66,30	20,94	76,31	22,72	86,20	24,47	95,99	26,24	99,87	26,97	105,66	28,07	115,23	29,99
		27	66,25	21,97	76,12	23,79	85,89	25,59	95,54	27,43	99,37	28,18	105,09	29,34	114,52	31,36

INDOOR FAN POWER INPUT (kW)

Minimum airflow	3,13	Nominal airflow	3,89	Maximum airflow	4,45
-----------------	------	-----------------	------	-----------------	------

OUTDOOR FAN POWER INPUT (kW)

Nominal airflow	5,76
-----------------	------

GC (kW) :	Gross cooling capacity	NH (kW) :	Net heating capacity	SC (kW) :	Sensible cooling capacity	AC (kW) :	Compressor absorbed power
------------------	------------------------	------------------	----------------------	------------------	---------------------------	------------------	---------------------------

COOLING CAPACITIES (multiply each value per 2)

Table 4.11a

CDC/H055+2xCIC/H030			Air inlet temperature at condenser (dry bulb)																		
Mixed air temperature °C	Indoor wet bulb	Indoor dry bulb	20 °C			25 °C			30 °C			35 °C			40 °C			45 °C			
			GC	SC	AC	GC	SC	AC	GC	SC	AC	GC	SC	AC	GC	SC	AC	GC	SC	AC	
Minimum airflow	4650 + 4650 m³/h	16	21	27,7	16,4	5,5	27,0	16,1	5,9	26,0	15,6	6,4	25,0	15,1	7,1	23,7	14,5	8,0	22,3	13,9	9,2
			24	27,8	20,1	5,5	27,1	19,7	5,9	26,2	19,2	6,5	25,1	18,7	7,1	23,9	18,0	8,0	22,5	17,2	9,2
			27	27,9	23,6	5,5	27,2	23,2	5,9	26,3	22,7	6,5	25,3	22,0	7,1	24,0	21,3	8,0	22,6	20,3	9,2
		19	24	30,2	16,2	5,6	29,4	15,8	6,1	28,4	15,4	6,6	27,2	14,9	7,2	25,9	14,4	8,1	24,4	13,8	9,3
			27	30,3	19,9	5,6	29,5	19,5	6,1	28,5	19,0	6,6	27,3	18,5	7,3	26,0	17,9	8,1	24,5	17,1	9,3
			30	30,4	23,3	5,6	29,6	23,0	6,1	28,6	22,5	6,6	27,5	21,9	7,3	26,2	21,2	8,1	24,7	20,3	9,4
		22	27	32,9	15,7	5,8	32,0	15,3	6,2	30,9	14,9	6,8	29,7	14,5	7,4	28,2	14,0	8,3	26,7	13,5	9,5
			30	33,0	19,4	5,8	32,1	19,0	6,2	31,0	18,6	6,8	29,8	18,1	7,4	28,4	17,6	8,3	26,8	16,9	9,5
			33	33,1	22,9	5,8	32,2	22,5	6,2	31,1	22,1	6,8	29,9	21,5	7,4	28,5	20,9	8,3	26,9	20,2	9,5
Nominal airflow	5450 + 5450 m³/h	16	21	28,4	17,2	5,7	27,6	16,9	6,1	26,6	16,4	6,6	25,4	15,9	7,3	24,1	15,3	8,2	22,7	14,6	9,5
			24	28,5	21,4	5,7	27,7	21,0	6,1	26,7	20,5	6,7	25,6	19,9	7,3	24,3	19,1	8,2	22,8	18,3	9,5
			27	28,6	25,3	5,7	27,8	24,9	6,1	26,9	24,4	6,7	25,7	23,7	7,3	24,5	22,8	8,2	23,0	21,8	9,5
		19	24	30,9	16,9	5,8	30,0	16,5	6,3	29,0	16,1	6,8	27,7	15,6	7,5	26,3	15,1	8,4	24,8	14,5	9,6
			27	31,0	21,1	5,8	30,1	20,7	6,3	29,1	20,3	6,8	27,9	19,7	7,5	26,5	19,0	8,4	24,9	18,3	9,6
			30	31,1	25,1	5,8	30,2	24,7	6,3	29,2	24,2	6,8	28,0	23,6	7,5	26,6	22,8	8,4	25,1	21,9	9,7
		22	27	33,6	16,3	6,0	32,7	16,0	6,4	31,5	15,6	7,0	30,2	15,2	7,7	28,8	14,7	8,6	27,1	14,2	9,8
			30	33,7	20,6	6,0	32,8	20,3	6,4	31,6	19,8	7,0	30,3	19,3	7,7	28,9	18,8	8,6	27,3	18,1	9,9
			33	33,8	24,6	6,0	32,9	24,3	6,4	31,8	23,8	7,0	30,5	23,3	7,7	29,0	22,6	8,6	27,4	21,8	9,9
Maximum airflow	6000 + 6000 m³/h	16	21	28,9	17,3	5,6	28,1	17,0	6,0	27,1	16,6	6,5	25,9	16,1	7,1	24,6	15,5	7,9	23,1	14,8	9,1
			24	29,0	21,9	5,6	28,2	21,5	6,0	27,2	21,0	6,5	26,1	20,4	7,1	24,8	19,6	7,9	23,3	18,8	9,1
			27	29,2	26,2	5,6	28,4	25,7	6,0	27,4	25,2	6,5	26,2	24,5	7,1	24,9	23,6	7,9	23,4	22,7	9,1
		19	24	31,5	16,9	5,7	30,6	16,6	6,1	29,5	16,2	6,6	28,2	15,7	7,3	26,8	15,2	8,1	25,2	14,6	9,3
			27	31,6	21,5	5,7	30,7	21,2	6,1	29,6	20,7	6,6	28,4	20,1	7,3	27,0	19,5	8,1	25,4	18,7	9,3
			30	31,7	25,9	5,7	30,8	25,5	6,1	29,8	25,0	6,7	28,5	24,4	7,3	27,1	23,6	8,1	25,6	22,6	9,3
		22	27	34,3	16,2	5,9	33,3	15,9	6,3	32,1	15,6	6,8	30,8	15,2	7,5	29,3	14,8	8,3	27,6	14,2	9,5
			30	34,4	20,9	5,9	33,4	20,6	6,3	32,2	20,2	6,8	30,9	19,7	7,5	29,4	19,1	8,3	27,7	18,5	9,5
			33	34,5	25,3	5,9	33,5	25,0	6,3	32,3	24,5	6,9	31,0	24,0	7,5	29,5	23,3	8,4	27,9	22,5	9,5

HEATING CAPACITIES (multiply each value per 2)

Table 4.11b

CDH055+2xCIH030			Air inlet temperature at condenser (dry bulb)													
Indoor Dry Bulb			-10 °C		-5 °C		0 °C		5 °C		7 °C		10 °C		15 °C	
			NH	AC	NH	AC	NH	AC	NH	AC	NH	AC	NH	AC	NH	AC
Minimum airflow	4650 + 4650 m³/h	15	19,3	4,76	22,3	5,33	25,3	5,87	28,2	6,40	29,3	6,60	31,0	6,92	33,8	7,46
		18	19,2	5,19	22,2	5,76	25,1	6,31	27,9	6,86	29,0	7,08	30,6	7,41	33,3	7,98
		20	19,1	5,48	22,1	6,07	24,9	6,63	27,7	7,18	28,8	7,41	30,4	7,75	33,0	8,35
		23	19,1	5,96	21,9	6,55	24,7	7,12	27,4	7,71	28,5	7,94	30,0	8,31	32,6	8,94
		25	19,1	6,29	21,9	6,89	24,6	7,48	27,2	8,08	28,3	8,32	29,8	8,70	32,3	9,37
		27	19,0	6,63	21,8	7,24	24,4	7,85	27,0	8,47	28,1	8,72	29,6	9,12	32,0	9,82
Nominal airflow	5450 + 5450 m³/h	15	19,7	4,73	22,8	5,25	25,9	5,74	28,9	6,22	30,0	6,41	31,8	6,70	34,6	7,19
		19	19,6	5,30	22,6	5,83	25,6	6,33	28,5	6,83	29,6	7,03	31,3	7,33	34,0	7,85
		20	19,6	5,45	22,6	5,98	25,5	6,48	28,4	6,98	29,5	7,19	31,2	7,50	33,9	8,03
		23	19,5	5,92	22,4	6,45	25,3	6,97	28,1	7,49	29,2	7,70	30,8	8,02	33,4	8,59
		25	19,5	6,26	22,3	6,79	25,2	7,31	27,9	7,84	29,0	8,06	30,6	8,40	33,2	8,98
		27	19,4	6,60	22,3	7,13	25,0	7,67	27,7	8,22	28,8	8,44	30,3	8,79	32,9	9,41
Maximum airflow	6000 + 6000 m³/h	15	19,8	4,51	23,0	5,02	26,1	5,49	29,1	5,94	30,3	6,12	32,1	6,39	35,0	6,85
		19	19,7	5,07	22,8	5,57	25,8	6,05	28,7	6,51	29,9	6,70	31,6	6,98	34,4	7,47
		20	19,6	5,22	22,7	5,72	25,7	6,19	28,6	6,66	29,8	6,85	31,5	7,14	34,3	7,63
		23	19,6	5,67	22,6	6,17	25,5	6,66	28,3	7,14	29,5	7,34	31,1	7,64	33,8	8,16
		25	19,5	5,99	22,5	6,49	25,3	6,98	28,1	7,47	29,2	7,68	30,9	7,99	33,5	8,53
		27	19,5	6,33	22,4	6,82	25,2	7,32	28,0	7,83	29,0	8,03	30,6	8,36	33,2	8,92

INDOOR FAN POWER INPUT (kW)			
Minimum airflow	0,68	Nominal airflow	0,86
Maximum airflow	1		
OUTDOOR FAN POWER INPUT (kW)			
Nominal airflow	2,68		

GC (kW) :	Gross cooling capacity	NH (kW) :	Net heating capacity	SC (kW) :	Sensible cooling capacity	AC (kW) :	Compressor absorbed power
------------------	------------------------	------------------	----------------------	------------------	---------------------------	------------------	---------------------------

COOLING CAPACITIES (multiply each value per 2)

Table 4.12a

CDC/H070+2xCIC/H035			Air inlet temperature at condenser (dry bulb)																		
Mixed air temperature °C	Indoor wet bulb	Indoor dry bulb	20 °C			25 °C			30 °C			35 °C			40 °C			45 °C			
			GC	SC	AC	GC	SC	AC	GC	SC	AC	GC	SC	AC	GC	SC	AC	GC	SC	AC	
Minimum airflow	6200 + 6200 m ³ /h	16	21	36,1	21,9	7,9	35,1	21,5	8,5	34,0	20,9	9,2	32,6	20,3	10,0	31,1	19,6	11,2	29,3	18,7	12,8
			24	36,2	27,3	7,9	35,3	26,8	8,5	34,1	26,1	9,2	32,8	25,4	10,0	31,3	24,5	11,2	29,6	23,4	12,9
			27	36,5	31,8	8,0	35,6	31,3	8,5	34,5	30,6	9,2	33,2	29,7	10,1	31,7	28,7	11,3	30,0	27,5	12,9
		19	24	39,2	21,5	8,2	38,1	21,1	8,7	36,9	20,6	9,4	35,4	20,0	10,3	33,7	19,4	11,4	31,8	18,6	13,1
			27	39,2	27,1	8,2	38,2	26,6	8,7	36,9	26,0	9,4	35,5	25,3	10,3	33,8	24,5	11,5	32,0	23,5	13,1
			30	39,5	31,8	8,2	38,5	31,3	8,7	37,3	30,6	9,4	35,8	29,8	10,3	34,2	28,9	11,5	32,4	27,8	13,2
		22	27	42,8	20,3	8,4	41,6	19,9	9,0	40,2	19,6	9,7	38,6	19,1	10,6	36,8	18,6	11,7	34,8	18,0	13,4
			30	42,7	26,3	8,4	41,6	25,9	9,0	40,2	25,4	9,7	38,6	24,7	10,6	36,8	24,0	11,7	34,8	23,2	13,4
			33	42,9	31,2	8,4	41,7	30,8	9,0	40,4	30,2	9,7	38,8	29,5	10,6	37,1	28,6	11,8	35,1	27,6	13,4
Nominal airflow	7100 + 7100 m ³ /h	16	21	36,6	22,8	8,2	35,6	22,3	8,8	34,4	21,7	9,5	33,1	21,1	10,3	31,5	20,3	11,5	29,7	19,4	13,2
			24	36,8	28,6	8,3	35,8	28,0	8,8	34,6	27,4	9,5	33,3	26,5	10,4	31,7	25,6	11,5	30,0	24,5	13,2
			27	37,1	33,6	8,3	36,2	33,0	8,9	35,1	32,3	9,6	33,8	31,3	10,4	32,2	30,3	11,6	30,5	29,0	13,3
		19	24	39,8	22,4	8,5	38,7	21,9	9,0	37,4	21,4	9,7	35,8	20,9	10,6	34,1	20,2	11,8	32,2	19,4	13,4
			27	39,9	28,5	8,5	38,8	28,0	9,0	37,5	27,4	9,7	36,0	26,6	10,6	34,3	25,7	11,8	32,4	24,7	13,5
			30	40,2	33,7	8,5	39,1	33,1	9,1	37,8	32,4	9,8	36,4	31,6	10,7	34,7	30,5	11,9	32,8	29,3	13,5
		22	27	43,4	21,2	8,7	42,1	20,9	9,3	40,7	20,5	10,0	39,1	20,0	10,9	37,2	19,5	12,1	35,2	18,8	13,7
			30	43,4	27,7	8,7	42,2	27,3	9,3	40,7	26,7	10,0	39,1	26,1	10,9	37,3	25,3	12,1	35,3	24,4	13,8
			33	43,6	33,2	8,7	42,4	32,7	9,3	41,0	32,1	10,0	39,4	31,3	10,9	37,6	30,4	12,1	35,6	29,3	13,8
Maximum airflow	8050 + 8050 m ³ /h	16	21	37,9	22,8	7,8	36,9	22,4	8,2	35,7	21,8	8,7	34,2	21,2	9,4	32,6	20,5	10,3	30,7	19,6	11,5
			24	38,1	29,2	7,8	37,1	28,7	8,3	35,9	28,0	8,8	34,5	27,2	9,5	32,9	26,3	10,4	31,1	25,1	11,6
			27	38,6	34,8	7,9	37,6	34,2	8,3	36,4	33,5	8,9	35,0	32,5	9,6	33,4	31,4	10,5	31,7	30,1	11,7
		19	24	41,1	22,3	8,0	40,0	21,9	8,5	38,6	21,4	9,0	37,0	20,9	9,7	35,3	20,2	10,6	33,3	19,5	11,9
			27	41,2	29,1	8,0	40,1	28,6	8,5	38,8	27,9	9,1	37,2	27,2	9,8	35,5	26,3	10,7	33,6	25,3	11,9
			30	41,6	34,9	8,1	40,5	34,3	8,5	39,2	33,6	9,1	37,7	32,7	9,8	36,0	31,7	10,8	34,0	30,5	12,0
		22	27	44,7	21,0	8,3	43,4	20,7	8,8	42,0	20,4	9,3	40,3	20,0	10,0	38,4	19,4	11,0	36,3	18,8	12,3
			30	44,8	28,2	8,3	43,5	27,8	8,8	42,1	27,3	9,3	40,4	26,6	10,1	38,5	25,9	11,0	36,5	25,0	12,3
			33	45,0	34,2	8,3	43,8	33,7	8,8	42,4	33,1	9,4	40,7	32,3	10,1	38,9	31,4	11,1	36,8	30,3	12,4

HEATING CAPACITIES (multiply each value per 2)

Table 4.12b

CDH070+2XCIH035			Air inlet temperature at condenser (dry bulb)														
Indoor Dry Bulb			-10 °C		-5 °C		0 °C		5 °C		7 °C		10 °C		15 °C		
Minimum airflow	Nominal airflow	Maximum airflow	NH	AC	NH	AC	NH	AC	NH	AC	NH	AC	NH	AC	NH	AC	
			6200 + 6200 m ³ /h	7100 + 7100 m ³ /h	8050 + 8050 m ³ /h	15	23,5	6,21	27,2	6,91	30,8	7,58	34,3	8,23	35,7	8,48	37,8
18	23,4	6,66				27,0	7,39	30,6	8,08	34,0	8,76	35,4	9,03	37,4	9,44	40,8	10,15
20	23,4	6,97				26,9	7,71	30,4	8,42	33,8	9,13	35,2	9,41	37,2	9,85	40,5	10,59
23	23,3	7,44				26,8	8,21	30,2	8,96	33,6	9,71	34,9	10,02	36,8	10,48	40,1	11,28
25	23,3	7,77				26,7	8,56	30,1	9,34	33,4	10,12	34,7	10,44	36,6	10,93	39,8	11,77
27	23,2	8,09				26,6	8,91	29,9	9,72	33,2	10,54	34,4	10,87	36,3	11,39	39,5	12,29
7100 + 7100 m ³ /h	8050 + 8050 m ³ /h	8050 + 8050 m ³ /h	15	24,0	6,29	27,8	6,94	31,5	7,55	35,1	8,14	36,5	8,37	38,7	8,73	42,2	9,33
			19	24,0	6,91	27,6	7,58	31,2	8,22	34,7	8,85	36,1	9,10	38,2	9,48	41,6	10,14
			20	23,9	7,07	27,6	7,75	31,1	8,40	34,6	9,04	36,0	9,29	38,1	9,68	41,4	10,35
			23	23,9	7,56	27,4	8,26	30,9	8,94	34,3	9,61	35,7	9,89	37,7	10,30	41,0	11,02
			25	23,8	7,90	27,3	8,61	30,8	9,31	34,1	10,02	35,5	10,30	37,4	10,74	40,7	11,50
			27	23,8	8,24	27,2	8,97	30,6	9,70	33,9	10,43	35,3	10,73	37,2	11,19	40,4	11,99
8050 + 8050 m ³ /h	8050 + 8050 m ³ /h	8050 + 8050 m ³ /h	15	24,0	5,95	27,9	6,56	31,6	7,12	35,3	7,67	36,8	7,89	39,0	8,21	42,6	8,76
			19	24,0	6,55	27,7	7,18	31,4	7,77	35,0	8,34	36,4	8,57	38,5	8,92	42,0	9,51
			20	23,9	6,71	27,6	7,34	31,3	7,93	34,9	8,52	36,3	8,75	38,4	9,10	41,8	9,70
			23	23,9	7,19	27,5	7,83	31,1	8,45	34,6	9,06	36,0	9,31	38,0	9,68	41,4	10,32
			25	23,8	7,51	27,4	8,17	30,9	8,80	34,4	9,44	35,8	9,69	37,8	10,08	41,1	10,76
			27	23,8	7,84	27,3	8,51	30,8	9,16	34,2	9,82	35,5	10,09	37,5	10,50	40,8	11,21

INDOOR FAN POWER INPUT (kW)

Minimum airflow	0,82	Nominal airflow	0,99	Maximum airflow	1,2
-----------------	------	-----------------	------	-----------------	-----

OUTDOOR FAN POWER INPUT (kW)

Nominal airflow	2,13
-----------------	------

GC (kW) :	Gross cooling capacity	NH (kW) :	Net heating capacity	SC (kW) :	Sensible cooling capacity	AC (kW) :	Compressor absorbed power
------------------	------------------------	------------------	----------------------	------------------	---------------------------	------------------	---------------------------

COOLING CAPACITIES (multiply each value per 2)

Table 4.13a

CDC/H085+2xCIC/H040			Air inlet temperature at condenser (dry bulb)																		
Mixed air temperature °C	Indoor wet bulb	Indoor dry bulb	20 °C			25 °C			30 °C			35 °C			40 °C			45 °C			
			GC	SC	AC	GC	SC	AC	GC	SC	AC	GC	SC	AC	GC	SC	AC	GC	SC	AC	
Minimum airflow	6950 + 6950 m³/h	16	21	42,1	24,7	9,1	41,0	24,2	9,7	39,6	23,5	10,5	38,0	22,8	11,5	36,1	21,9	12,9	33,9	20,8	14,9
			24	42,1	30,5	9,1	41,1	29,9	9,8	39,7	29,2	10,5	38,1	28,3	11,6	36,2	27,2	13,0	34,1	25,9	15,0
			27	42,4	35,6	9,1	41,3	35,0	9,8	40,0	34,2	10,6	38,4	33,2	11,6	36,6	31,9	13,0	34,5	30,5	15,0
		19	24	45,8	24,2	9,4	44,5	23,7	10,0	43,0	23,1	10,8	41,2	22,4	11,8	39,1	21,6	13,2	36,8	20,6	15,2
			27	45,8	30,2	9,4	44,6	29,6	10,0	43,1	28,9	10,8	41,3	28,1	11,8	39,2	27,1	13,2	36,9	25,9	15,3
			30	46,0	35,4	9,4	44,8	34,8	10,0	43,3	34,0	10,8	41,6	33,1	11,9	39,5	31,9	13,3	37,2	30,6	15,3
		22	27	50,0	22,9	9,6	48,5	22,5	10,3	46,8	22,0	11,1	44,9	21,4	12,2	42,6	20,8	13,6	40,1	20,0	15,6
			30	49,9	29,2	9,6	48,5	28,7	10,3	46,8	28,1	11,1	44,9	27,4	12,2	42,7	26,5	13,6	40,2	25,5	15,6
			33	50,0	34,6	9,6	48,6	34,1	10,3	47,0	33,4	11,1	45,1	32,5	12,2	42,9	31,5	13,6	40,5	30,3	15,7
Nominal airflow	8150 + 8150 m³/h	16	21	42,8	25,9	9,6	41,6	25,4	10,2	40,2	24,7	11,0	38,5	23,9	12,1	36,5	22,9	13,5	34,3	21,8	15,7
			24	43,0	32,3	9,6	41,8	31,6	10,2	40,4	30,8	11,1	38,7	29,8	12,1	36,8	28,7	13,6	34,6	27,3	15,7
			27	43,3	37,9	9,6	42,2	37,2	10,3	40,8	36,3	11,1	39,2	35,2	12,2	37,2	33,9	13,7	35,1	32,3	15,8
		19	24	46,6	25,5	9,8	45,2	24,9	10,5	43,6	24,3	11,3	41,7	23,6	12,4	39,6	22,7	13,9	37,2	21,7	16,0
			27	46,6	32,0	9,8	45,3	31,4	10,5	43,8	30,7	11,3	41,9	29,7	12,4	39,8	28,7	13,9	37,4	27,4	16,1
			30	46,9	37,8	9,9	45,7	37,1	10,5	44,1	36,3	11,4	42,3	35,2	12,5	40,2	34,0	13,9	37,9	32,5	16,1
		22	27	50,7	24,3	10,1	49,2	23,9	10,8	47,5	23,3	11,6	45,4	22,7	12,7	43,1	22,0	14,2	40,6	21,2	16,4
			30	50,7	31,2	10,1	49,3	30,6	10,8	47,5	30,0	11,6	45,5	29,2	12,7	43,3	28,2	14,2	40,7	27,1	16,4
			33	51,0	37,2	10,1	49,5	36,5	10,8	47,8	35,8	11,7	45,8	34,9	12,8	43,6	33,7	14,3	41,1	32,4	16,5
Maximum airflow	9050 + 9050 m³/h	16	21	43,7	26,0	9,5	42,4	25,4	10,1	40,9	24,8	10,8	39,2	24,0	11,8	37,1	23,0	13,1	34,8	21,9	15,0
			24	43,9	32,8	9,5	42,7	32,1	10,1	41,2	31,3	10,9	39,5	30,3	11,8	37,5	29,1	13,2	35,2	27,7	15,1
			27	44,3	38,8	9,6	43,2	38,1	10,2	41,7	37,2	10,9	40,0	36,1	11,9	38,0	34,7	13,2	35,8	33,1	15,1
		19	24	47,4	25,5	9,7	46,0	25,0	10,4	44,4	24,4	11,1	42,4	23,6	12,1	40,2	22,8	13,5	37,8	21,8	15,4
			27	47,6	32,5	9,8	46,2	31,9	10,4	44,6	31,1	11,2	42,7	30,2	12,2	40,5	29,1	13,5	38,1	27,8	15,5
			30	47,9	38,7	9,8	46,6	38,0	10,4	45,0	37,2	11,2	43,1	36,1	12,2	41,0	34,9	13,6	38,6	33,3	15,5
		22	27	51,6	24,3	10,0	50,0	23,9	10,7	48,2	23,4	11,5	46,1	22,8	12,5	43,8	22,1	13,9	41,2	21,3	15,9
			30	51,7	31,6	10,1	50,2	31,1	10,7	48,4	30,4	11,5	46,3	29,6	12,5	44,0	28,7	13,9	41,4	27,6	15,9
			33	52,0	38,0	10,1	50,5	37,4	10,7	48,7	36,7	11,5	46,7	35,7	12,5	44,4	34,6	13,9	41,8	33,2	15,9

HEATING CAPACITIES (multiply each value per 2)

Table 4.13b

CDH085+2XCIH040			Air inlet temperature at condenser (dry bulb)													
Indoor Dry Bulb			-10 °C		-5 °C		0 °C		5 °C		7 °C		10 °C		15 °C	
			NH	AC	NH	AC	NH	AC	NH	AC	NH	AC	NH	AC	NH	AC
Minimum airflow	6950 + 6950 m³/h	15	27,4	6,96	31,6	7,78	35,8	8,56	39,9	9,32	41,5	9,62	44,0	10,07	47,9	10,84
		18	27,3	7,48	31,5	8,33	35,6	9,14	39,6	9,94	41,2	10,26	43,6	10,74	47,4	11,56
		20	27,3	7,84	31,4	8,71	35,4	9,54	39,4	10,37	40,9	10,70	43,3	11,21	47,1	12,07
		23	27,2	8,39	31,2	9,29	35,2	10,17	39,0	11,05	40,6	11,41	42,9	11,95	46,6	12,89
		25	27,2	8,77	31,1	9,70	35,0	10,61	38,8	11,53	40,3	11,90	42,6	12,47	46,3	13,47
27	27,1	9,16	31,0	10,11	34,8	11,06	38,6	12,02	40,1	12,42	42,3	13,02	45,9	14,07		
Nominal airflow	8150 + 8150 m³/h	15	28,1	7,05	32,4	7,80	36,7	8,51	40,9	9,20	42,6	9,47	45,1	9,89	49,2	10,58
		19	28,0	7,76	32,2	8,54	36,4	9,28	40,5	10,02	42,1	10,31	44,5	10,75	48,5	11,51
		20	28,0	7,94	32,2	8,73	36,3	9,48	40,4	10,23	42,0	10,53	44,4	10,98	48,3	11,76
		23	27,9	8,50	32,0	9,32	36,1	10,11	40,1	10,89	41,6	11,21	44,0	11,70	47,8	12,53
		25	27,9	8,89	31,9	9,72	35,9	10,54	39,8	11,35	41,4	11,69	43,7	12,19	47,5	13,07
27	27,8	9,28	31,8	10,13	35,8	10,98	39,6	11,83	41,1	12,18	43,4	12,71	47,1	13,64		
Maximum airflow	9400 + 9400 m³/h	15	28,4	6,92	32,9	7,61	37,3	8,26	41,6	8,89	43,3	9,13	45,8	9,51	50,0	10,13
		19	28,4	7,62	32,7	8,33	37,0	9,00	41,2	9,66	42,8	9,92	45,3	10,32	49,4	10,99
		20	28,3	7,80	32,6	8,51	36,9	9,19	41,0	9,86	42,7	10,13	45,2	10,53	49,2	11,22
		23	28,3	8,34	32,5	9,07	36,6	9,78	40,7	10,48	42,3	10,76	44,7	11,19	48,7	11,92
		25	28,2	8,71	32,4	9,46	36,5	10,18	40,5	10,91	42,1	11,20	44,5	11,65	48,3	12,42
27	28,2	9,09	32,3	9,85	36,3	10,60	40,3	11,35	41,8	11,65	44,2	12,12	48,0	12,93		

INDOOR FAN POWER INPUT (kW)			
Minimum airflow	1,12	Nominal airflow	1,42
Maximum airflow	1,67		

OUTDOOR FAN POWER INPUT (kW)	
Nominal airflow	2,05

GC (kW) :	Gross cooling capacity	NH (kW) :	Net heating capacity	SC (kW) :	Sensible cooling capacity	AC (kW) :	Compressor absorbed power
------------------	------------------------	------------------	----------------------	------------------	---------------------------	------------------	---------------------------

HOT WATER COIL

Table 4.2

INDOOR UNIT MODELS CIC/CIH	Temperature difference between water inlet and air inlet			Water flow	Water coil pressure drop	Air pressure drop Pa		Nr of rows	Weight	Water outlet diameter
	50 °C	60 °C	70 °C			Nominal air flow	Minimum air flow			
	CAPACITY W			L/H	kPa			Kg		
20 S	24	29	34	2100	36	20	15	2	10	3/4"
25 S	29	35	41	2500	54	32	25	2	10	3/4"
30 S	30	37	43	2600	57	37	25	2	10	3/4"
35 S	42	51	60	3700	40	32	25	2	12	1"
40 S	46	56	65	4000	47	40	31	2	16	1"
45 D	50	60	71	4400	56	50	38	2	20	1"
55 D	69	83	98	6000	30	31	24	2	20	1 1/4"
70 D	79	96	112	6900	39	44	34	2	24	1 1/4"
85 D	86	104	122	7500	46	53	41	2	30	1 1/4"
100 D	129	156	183	11300	42	30	23	2	40	1 1/2"

ELECTRICAL COIL SELECTION

Table 4.3

INDOOR UNIT MODELS			SIZE										
			20 S	25 S	30 S	35 S	40 S	45 D	55 D	70 D	85 D	100 D	
STANDARD	Capacity	kW	10	10	10	15	15	15	20	20	20	30	
	Nr of stages		1	1	1	2	2	2	2	2	2	2	
	Temperature rise	°C	8,2	6,1	5,6	6,4	5,6	4,8	5,2	4,1	3,7	4,5	
MEDIUM	Capacity	kW	15	15	15	20	20	20	27	27	27	40	
	Nr of stages		2	2	2	2	2	2	2	2	2	2	
	Temperature rise	°C	12,3	9,1	8,3	8,5	7,4	6,4	7	5,6	5	5,9	
HIGH HEAT 2 STEPS	Capacity	kW	20	20	20	27	27	27	40	40	40	50	
	Nr of stages		2	2	2	2	2	2	2	2	2	1	
	Temperature rise	°C	16,4	12,1	11,1	11,5	10	8,7	10,4	8,3	7,5	7,4	
HIGH HEAT MODULATING	Capacity	kW	20	20	20	27	27	27	40	40	40	50	
	Nr of stages		n/a										
	Temperature rise	°C	16,4	12,1	11,1	11,5	10	8,7	10,4	8,3	7,5	7,4	

INDOOR NOISE LEVEL - IN DUCT

STANDARD

Table 4.4a

Spectrum per octave band (dB(A))

CIC/CIH	125	250	500	1000	2000	4000	8000	Total sound power
								Lw dB(A)
20 S	75,6	68,8	68,1	69,0	66,5	61,9	53,6	73
25 S	80,6	73,4	72,8	73,8	71,8	68,4	60,9	78
30 S	81,6	74,6	74,3	75,3	73,4	70,2	63,2	80
35 S	78,4	78,5	75,5	74,7	74,3	70,9	65,3	80
40 S	81,3	80,8	78,4	77,4	77,1	74,2	69,0	83
45 D	83,9	83,0	81,2	80,0	79,8	77,3	72,6	86
55 D	79,1	79,1	75,4	74,4	74,1	70,6	64,4	80
70 D	84,7	82,4	80,1	78,6	78,4	75,8	70,4	85
85 D	86,5	83,7	82,6	80,3	80,2	78,0	73,0	87
100 D	84,3	82,8	81,4	79,0	79,0	75,8	68,4	85

OUTDOOR NOISE LEVEL - IN DUCT

STANDARD UNIT

Table 4.4c

Spectrum per octave band (dB(A))

CSC/CSH CDC/CDH CMC/CMH	125	250	500	1000	2000	4000	8000	Total sound power
								Lw dB(A)
20 S	75,6	77,7	75,4	74,4	73,4	71,5	65,9	80
25 S	78,6	79,4	78,2	76,4	76,1	74,0	69,1	83
30 S	81,4	81,5	81,9	79,5	79,6	77,5	73,3	86
35 S	79,4	80,5	80,2	77,4	77,5	75,2	68,1	84
40 S	79,2	80,2	79,8	77,4	77,6	74,7	67,9	84
45 D	81,7	83,1	83,5	80,5	80,9	80,6	72,8	88
55 D	85,6	81,3	83,4	80,1	81,5	78,8	72,9	87
70 D	85,5	81,9	84,2	81,1	81,6	79,2	73,1	88
85 D	85,8	82,5	85,0	82,2	82,6	80,0	74,2	89
100 D	85,6	87,1	88,9	85,7	85,3	84,1	78,6	92

WITH INVERTER LOW NOISE CONTROL *

Table 4.4d

Spectrum per octave band (dB(A))

CSC/CSH CDC/CDH CMC/CMH	63	125	250	500	1000	2000	4000	8000	Total sound power
									Lw dB(A)
20 S	64,6	66,1	68,2	66,8	67,8	65,5	64,7	58,8	73
25 S	66,1	69,6	70,4	69,0	67,1	67,5	64,5	63,0	74
30 S	67,3	71,9	72,0	72,4	69,7	70,6	67,6	66,3	77
35 S	67,9	70,4	71,5	71,2	67,9	69,0	65,8	61,3	75
40 S	67,8	70,2	71,2	70,7	67,7	68,9	65,4	61,8	75
45 D	68,3	72,2	73,6	73,9	70,8	71,5	70,6	66,1	78
55 D	74,3	76,1	71,8	73,8	70,2	72,6	68,7	67,7	78
70 D	75,1	76,5	72,9	75,2	71,7	72,9	69,9	65,6	79
85 D	75,3	76,8	73,5	76,0	72,7	73,8	70,9	66,8	80
100 D	73,5	76,6	78,1	79,9	76,5	76,4	75,0	70,5	83

Conditions: indoor temperature 21°C DB / 15°C WB; outdoor temperature: 25°C
At minimum speed

RADIATED NOISE LEVEL

MONOBLOC - STANDARD

Table 4.4d

Spectrum per octave band (dB(A))

CMC/CMH	125	250	500	1000	2000	4000	8000	Total sound power
								Lw dB(A)
20 S	70,5	71,6	70,7	70,9	67,0	65,8	58,6	75
25 S	80,5	73,4	71,0	71,0	70,9	67,6	61,2	77
30 S	83,0	75,3	71,9	73,2	74,9	70,3	64,1	80
35 S	80,9	75,7	71,7	72,7	72,7	67,6	59,4	78
40 S	81,1	76,7	73,7	74,5	74,0	67,5	61,2	80
45 D	83,6	79,2	77,1	75,9	75,0	71,5	65,3	82
55 D	86,8	76,5	73,8	74,5	77,6	73,0	66,6	82
70 D	87,0	78,3	75,9	76,2	76,1	71,1	63,2	82
85 D	87,5	79,3	77,8	77,7	77,4	71,2	64,9	83
100 D	86,7	80,0	74,7	76,4	77,8	73,5	65,8	83

MONOBLOC - WITH INVERTER LOW NOISE CONTROL *

Table 4.4e

Spectrum per octave band (dB(A))

CMC/CMH	125	250	500	1000	2000	4000	8000	Total sound power
								Lw dB(A)
20 S	70,5	71,6	70,6	70,3	65,3	63,5	57,4	74
25 S	80,5	73,3	68,2	68,9	67,1	61,2	61,2	74
30 S	83,0	75,3	70,3	70,9	70,2	64,3	64,1	77
35 S	80,9	75,7	70,7	69,8	68,9	62,5	59,4	76
40 S	81,1	76,7	73,1	71,9	69,9	63,5	61,2	77
45 D	83,6	79,2	76,0	74,6	72,5	68,1	65,3	80
55 D	86,8	76,4	71,5	70,6	72,1	65,5	66,6	78
70 D	87,0	78,3	75,1	73,7	72,7	66,8	63,2	80
85 D	87,5	79,3	77,4	75,2	73,9	68,2	64,9	81

SPLIT - STANDARD

Table 4.4f

Spectrum per octave band (dB(A))

CSC/CSH CDC/CDH	125	250	500	1000	2000	4000	8000	Total sound power
								Lw dB(A)
20 S	67,5	71,1	70,0	70,2	66,6	65,7	58,6	75
25 S	79,7	72,3	68,9	68,4	70,4	67,4	61,0	76
30 S	82,5	74,4	69,3	71,0	74,7	70,2	63,9	79
35 S	80,5	73,4	67,5	70,7	72,1	67,3	58,5	77
40 S	80,3	73,1	67,2	71,8	73,1	66,6	59,8	78
45 D	82,8	76,0	72,4	71,7	73,8	71,2	64,1	79
55 D	86,7	74,2	71,7	73,4	77,5	72,9	66,5	82
70 D	86,6	74,8	70,9	73,9	75,4	70,5	61,9	80
85 D	86,9	75,4	71,2	75,1	76,6	70,4	63,3	81
100 D	86,7	80,0	74,7	76,4	77,8	73,5	65,8	83

Conditions: indoor temperature 21°C DB / 15°C WB; outdoor temperature: 25°C
At minimum speed

RADIATED NOISE LEVEL

SPLIT - WITH INVERTER LOW NOISE CONTROL*

Table 4.4g

Spectrum per octave band (dB(A))

CSC/CSH CDC/CDH	125	250	500	1000	2000	4000	8000	Total sound power
								Lw dB(A)
20 S	63,6	65,7	65,1	66,9	64,2	63,9	57,7	71
25 S	67,1	67,9	66,7	64,8	65,8	62,3	62,1	72
30 S	69,4	69,5	70,0	67,4	69,1	65,3	65,2	75
35 S	67,9	69,0	68,8	65,7	67,4	63,4	60,1	73
40 S	67,7	68,7	68,3	65,5	67,5	63,1	60,9	73
45 D	67,7	69,1	69,6	66,6	68,4	66,4	64,6	74
55 D	73,6	69,3	71,4	68,0	71,3	66,6	67,1	76
70 D	74,0	70,4	72,7	69,4	71,2	67,5	64,1	77
85 D	74,5	71,2	73,7	70,6	72,1	68,7	65,5	78
100 D	72,1	73,6	75,4	72,3	73,0	70,6	67,5	79

Conditions: indoor temperature 21°C DB / 15°C WB; outdoor temperature: 25°C
At minimum speed

EXHAUST FAN SOUND LEVEL

SIZE	Lw dB(A) *
20 S --> 35 S	64
40 S --> 55 D	66
70 D - 85 D	73
100 D	76

* Free field noise measurement at 1 meter.

Table 4.4h

To locate the outdoor and the indoor units, refer to the following information :

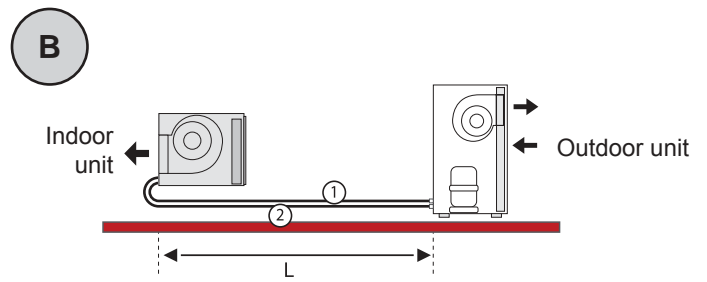
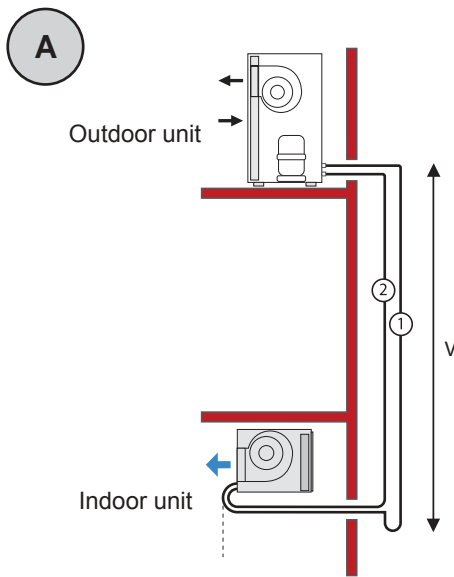

Standard unit : 40 meters with long distance option = 65 m.

V : Maximum vertical length = 16 meters

L : Maximum total length (vertical + horizontal = 65 meters)

1	Circuit 1
2	Circuit 2

REFRIGERANT LINES SELECTION

Table 4.5

Refrigerant lines			Unit - Model												
			20 S	25 S	30 S	35 S	40 S	45 D	55 D	70 D	85 D	100 D			
Total line length (length refrigerant lines between indoor unit and outdoor unit)	0 ▶ 30 m.	Liquid Ø	C1	1/2"	5/8"	5/8"	5/8"	5/8"	5/8"	5/8"	5/8"	5/8"	5/8"	5/8"	3/4"
			C2	n/a	n/a	n/a	n/a	n/a	5/8"	5/8"	5/8"	5/8"	5/8"	5/8"	
		Gas Ø	C1	7/8"	1 1/8"	1 1/8"	1 3/8"	1 3/8"	1 1/8"	1 1/8"	1 3/8"	1 3/8"	1 3/8"	1 3/8"	1 5/8"
			C2	n/a	n/a	n/a	n/a	n/a	1 1/8"	1 1/8"	1 3/8"	1 3/8"	1 3/8"	1 3/8"	
	Maxi number of bends			6	12	8	18	12	12	8	18	12	12		
	30 ▶ 40 m.	Liquid Ø	C1	5/8"	5/8"	5/8"	3/4"	3/4"	5/8"	5/8"	3/4"	3/4"	3/4"	7/8"	
			C2	n/a	n/a	n/a	n/a	n/a	5/8"	5/8"	3/4"	3/4"	3/4"		
		Gas Ø	C1	1 1/8"	1 1/8"	1 3/8"	1 3/8"	1 5/8"	1 1/8"	1 3/8"	1 3/8"	1 5/8"	1 5/8"	1 5/8"	
			C2	n/a	n/a	n/a	n/a	n/a	1 1/8"	1 3/8"	1 3/8"	1 5/8"	1 5/8"		
	Maxi number of bends			12	18	18	18	18	18	18	18	18	12		
	40 ▶ 65 m (1).	Liquid Ø	C1	5/8"	5/8"	5/8"	3/4"	3/4"	5/8"	5/8"	3/4"	3/4"	3/4"	7/8"	
			C2	n/a	n/a	n/a	n/a	n/a	5/8"	5/8"	3/4"	3/4"	3/4"		
Gas Ø		C1	1 1/8"	1 1/8"	1 3/8"	1 3/8"	1 5/8"	1 1/8"	1 3/8"	1 3/8"	1 5/8"	1 5/8"	1 5/8"		
		C2	n/a	n/a	n/a	n/a	n/a	1 1/8"	1 3/8"	1 3/8"	1 5/8"	1 5/8"			
Maxi number of bends			12	18	18	18	18	18	18	18	18	12			

(1) : Long distance refrigerant connection option required.

MONOBLOC

Table 5.1

COMPACTAIR™ CMC - CMH		20 S	25 S	30 S	35 S	40 S	45 D	55 D	70 D	85 D
Voltage		400V/3+N/50 Hz								
Maximum absorbed power	kW	10,4	13,44	15,94	20,08	22,28	26,52	31,67	40,01	46,12
Start-up current	A	89,8	100,4	107,7	142,6	157,5	126,6	136,7	176	220,5
Maximum current	A	19	27	29,4	33,9	40,6	53,3	58,4	67,3	83,6

CONDENSING SECTION

Table 5.2a

COMPACTAIR™ CSC - CSH		20 S	25 S	30 S	35 S	40 S	45 D	55 D	70 D	85 D	100 D
Voltage		400V/3+N/50 Hz									
Maximum absorbed power	kW	9,7	11,99	14,49	18,19	19,59	23,83	28,98	36,38	41,06	50,25
Start-up current	A	88,4	97,8	105,1	139,1	152,7	121,8	131,9	169,5	191,9	207,9
Maximum current	A	17,59	24,45	26,8	30,4	35,8	48,48	53,6	60,8	74,96	91

COMPACTAIR™ CDC - CDH		55 D	70 D	85 D
Voltage		400V/3+N/50 Hz		
Maximum absorbed power	kW	28,98	36,38	41,06
Start-up current	A	210,2	278,2	308,8
Maximum current	A	53,6	60,8	79,96

AIR TREATMENT SECTION

Table 5.2b

COMPACTAIR™ CIC - CIH (*)		20 S	25 S	30 S	35 S	40 S	45 D	55 D	70 D	85 D	100 D
Voltage		400V/3+N/50 Hz									
Maximum absorbed power	kW	0,74	1,45	1,45	1,89	2,69	2,69	2,69	3,63	5,06	5,06
Start-up current	A	6,4	13	13	17,3	26,4	26,4	26,4	35,6	60,2	60,2
Maximum current	A	1,4	2,6	2,6	3,5	4,8	4,8	4,8	6,5	8,6	8,6

(*) : For dual split air treatment section sizes, please refer to below table.

UNIT CONFIGURATIONS

COMPACTAIR™		20S	25S	30S	35S	40S	45D	55D	70D	85D	100D
Monobloc	CMC / CMH										
Split	CSC/CSH - CIC/CIH										
Dual Split	CDC / CDH - 2x CIC/CIH							2x30S	2x35S	2x40S	

OPTIONS

Table 5.3

COMPACTAIR™ - CMC / CMH	20 S		25 S		30 S		35 S		40 S	
	P	FLA	P	FLA	P	FLA	P	FLA	P	FLA
Air treatment section - CIC/CIH										
Standard supply fan	0	0	0	0	0	0	0	0	0	0
High pressure fan HP1	0,71	1,19	0,44	0,86	0,44	0,86	0,8	1,35	0	0
High pressure fan HP2	0,71	1,19	1,24	2,21	1,24	2,21	1,74	3,03	0,94	1,68
High pressure fan HP3	1,15	2,05	1,24	2,21	2,18	3,89	1,74	3,03	2,37	3,80
Exhaust module	0,51	2,6	0,51	2,6	0,51	2,6	1,33	6,8	1,33	6,8
Return module	-	-	-	-	-	-	-	-	-	-
Electrical heater - Standard	10	14,3	10	14,3	10	14,3	15	21,5	15	21,5
Electrical heater - Medium	15	21,5	15	21,5	15	21,5	20	28,6	20	28,6
Electrical heater - High	20	28,6	20	28,6	20	28,6	27	39	27	39

COMPACTAIR™ - CMC / CMH	45 D		55 D		70 D		85 D		100 D	
	P	FLA	P	FLA	P	FLA	P	FLA	P	FLA
Air treatment section - CIC/CIH										
Standard supply fan	0	0	0	0	0	0	0	0	0	0
High pressure fan HP1	0,94	1,68	0,94	1,68	1,43	2,12	1,32	2,5	1,32	2,5
High pressure fan HP2	2,34	3,80	2,37	3,80	2,75	4,62	3,73	6,70	5,06	8,60
High pressure fan HP3	2,37	3,80	3,69	6,30	5,16	8,82	3,73	6,70	5,06	8,60
Exhaust module	1,33	6,8	2,65	4,5	2,65	4,5	2,65	4,5	5,3	9
Return module	-	-	2,69	4,8	3,83	6,5	3,83	6,5	5,06	8,6
Electrical heater Standard	15	21,5	20	28,6	20	28,6	20	28,6	27	39
Electrical heater Medium	20	28,6	27	39	27	39	27	39	40	57,8
Electrical heater - High	27	39	40	57,8	40	57,8	40	57,8	50	72,3

P	Max. absorbed power in kW	FLA	Full load amps (A)
----------	---------------------------	------------	--------------------

COMPACTAIR™		45D	55D	70D	85D	100D
Monobloc	CMC / CMH					
Split	CSC/CSH - CIC/CIH					
Dual Split	CDC / CDH - 2x CIC/CIH		2x30S	2x35S	2x40S	



- BEFORE MAKING ANY ELECTRICAL CONNECTIONS, ENSURE THAT ALL CIRCUIT BREAKERS ARE OPEN.
- IN ORDER TO CARRY OUT THE ELECTRICAL CONNECTIONS, FOLLOW THE ELECTRICAL DIAGRAM SUPPLIED WITH THE UNIT.

STANDARD VERSION

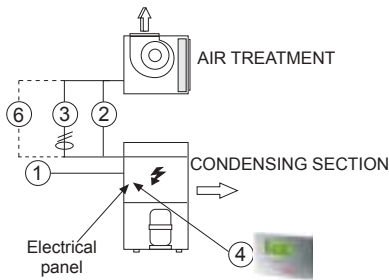

C50 VERSION

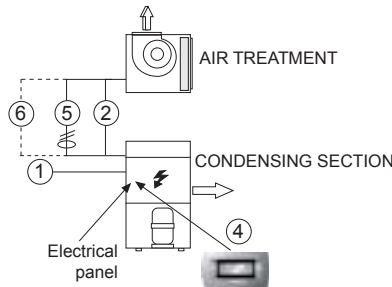

DUAL SPLIT VERSION

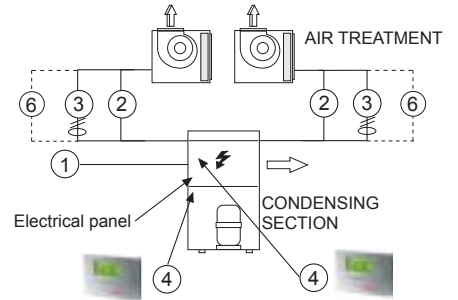

1	Power supply	3	Indoor coil sensor. (STD and dual split only).	5	Discharge sensor (C50 Only).
2	Indoor fan motor electrical connection	4	Terminal connection (see electrical connection for the controller).	6	Electrical heater connection (optional).

WIRING

STANDARD + C50 VERSION									
	Supply without electrical heater	Supply with electrical heater	Connection between outdoor units	Supply fan motor	Indoor coil sensor	Discharge sensor C50	Supply electrical heater (mm ²)		
	1	1"		2	3	5	6		
							STANDARD	MEDIUM	HIGH
020	5 x 4 mm ²	5 x 10 mm ²	2 x (4 x 4 mm ²) + 10 x 1,5 mm ² + 6 x 1 mm ²	4 x 1,5 mm ²	2 x 1 mm ² shielded	2 x 1 mm ² shielded	4 x 2,5 + 4 x 1,5 mm ²	4 x 4 + 4 x 1,5 mm ²	4 x 6 + 4 x 1,5 mm ²
025	5 x 6 mm ²	5 x 16 mm ²					4 x 4 + 4 x 1,5 mm ²	4 x 6 + 4 x 1,5 mm ²	4 x 10 + 4 x 1,5 mm ²
030	5 x 6 mm ²	5 x 16 mm ²					4 x 6 + 4 x 1,5 mm ²	4 x 10 + 4 x 1,5 mm ²	4 x 16 + 4 x 1,5 mm ²
035	5 x 6 mm ²	3 x 25 + 2 x 16 mm ²		4 x 1,5 mm ² (STD & HP1) 4 x 2,5 mm ² (HP2 & HP3)	4 x 1 mm ² shielded	2 x 1 mm ² shielded	4 x 4 + 4 x 1,5 mm ²	4 x 6 + 4 x 1,5 mm ²	4 x 10 + 4 x 1,5 mm ²
040	5 x 10 mm ²	3 x 25 + 2 x 16 mm ²					4 x 6 + 4 x 1,5 mm ²	4 x 10 + 4 x 1,5 mm ²	4 x 16 + 4 x 1,5 mm ²
045	5 x 16 mm ²	3 x 35 + 2 x 16 mm ²					4 x 10 + 4 x 1,5 mm ²	4 x 16 + 4 x 1,5 mm ²	4 x 25 + 4 x 1,5 mm ²
055	5 x 16 mm ²	3 x 50 + 2 x 25 mm ²							
070	3 x 25 + 2 x 16 mm ²	3 x 70 + 2 x 35 mm ²							
085	3 x 25 + 2 x 16 mm ²	3 x 70 + 2 x 35 mm ²							
100	3 x 35 + 2 x 16 mm ²	3 x 95 + 2 x 50 mm ²							

DUAL SPLIT VERSION							
	Supply without electrical heater	Supply with electrical heater	Supply fan motor	Indoor coil sensor	Supply electrical heater (mm ²)		
	1	1"	2	3	6		
					STANDARD	MEDIUM	HIGH
055	5 x 16 mm ²	3 x 10 + 2 x 25	2 x [4 x 1,5 mm ²]		2 x [4x2,5 + 4x1,5 mm ²]	2 x [4x4 + 4x1,5 mm ²]	2 x [4x6 + 4x1,5 mm ²]
070	5 x 6 mm ²	5 x 16 mm ²			2 x [4x4 + 4x1,5 mm ²]	2 x [4x6 + 4x1,5 mm ²]	2 x [4x10 + 4x1,5 mm ²]
085	5 x 6 mm ²	5 x 16 mm ²					

Note: For units with two circuits, indoor coil sensor IS1, must be connected with circuit C1 and indoor coil sensor IS2 with circuit C2, otherwise the protection will not work correctly.
The length of all cables for connection with indoor unit must be less than 65 m.

SPLIT VERSION WITH ECONOMIZER

STANDARD VERSION

WITH C50 OPTION

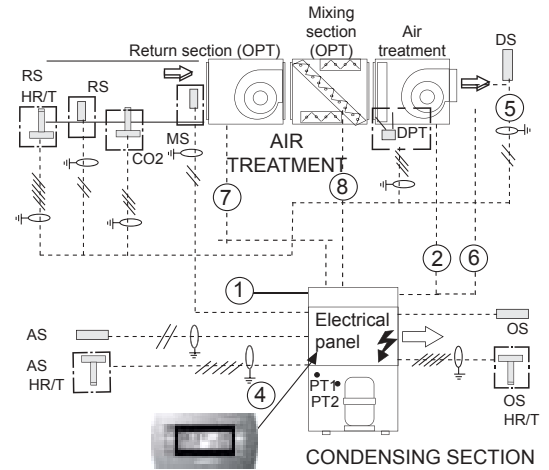
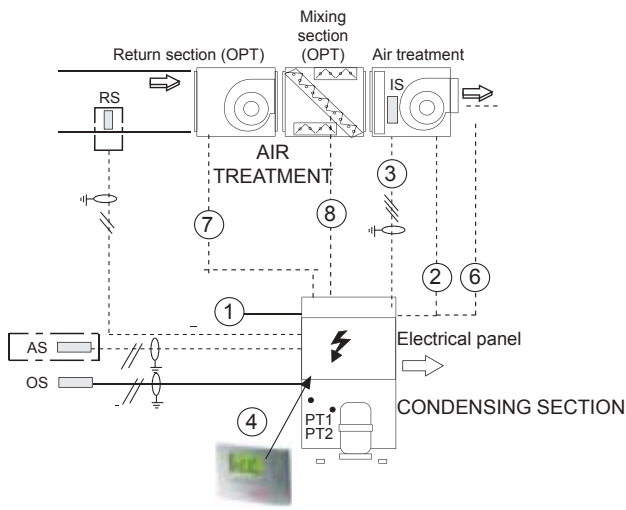

1	Electrical supply
2	Indoor motor fan electrical connection
3	Indoor coil sensor. (STD and D2 Only)
4	Terminal connection (see electrical connection for the controller)
5	Discharge sensor (C50 Only)
6	Electrical heater connection (option)
7	Exhaust fan or return fan connection
8	Free-cooling connection

DUAL SPLIT VERSION

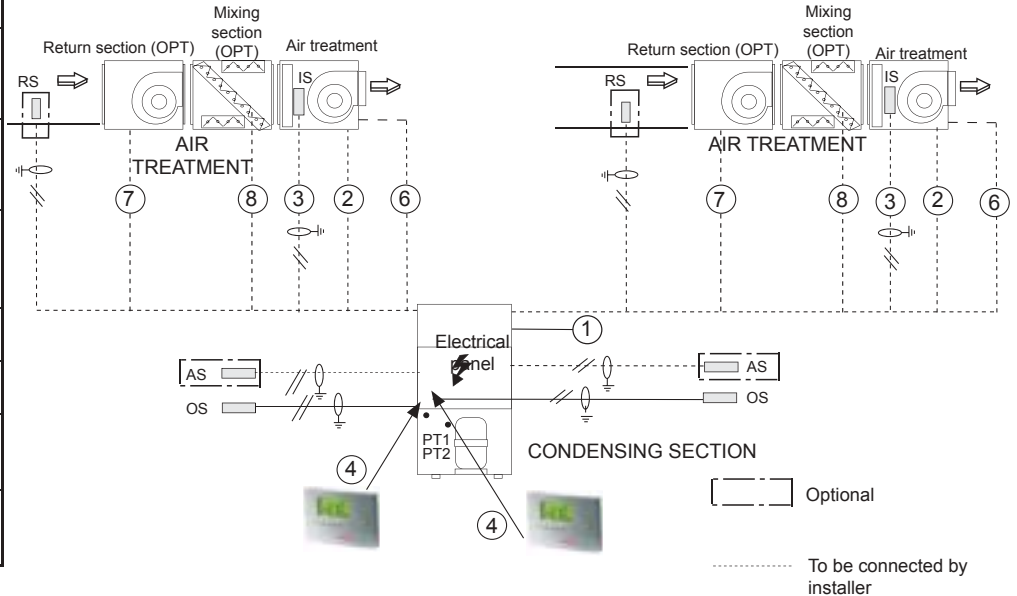

CONTROL CONNECTION ELEMENTS:

	COMPONENTS	VERSION			No. OF CABLES X SECTION
		STANDARD	C50	DUAL SPLIT	
DS	Discharge sensor				2 x 1 mm ² (shielded)
OS	Outdoor sensor	STANDARD	STANDARD	STANDARD	
AS	Remote ambient sensor	OPTION		OPTION	
RS	Duct sensor. Replaces AS				
IS	Liquid-gas pipe sensor	STANDARD		STANDARD	5 x 1 mm ² (shielded)
MS	Duct sensor for thermostatic and enthalpic free cooling.		OPTION		
RS HR/T	Duct remote sensor for enthalpic free cooling.				3 x 1 mm ² (shielded)
CO ₂	CO ₂ Air quality probe available only with enthalpic free cooling.				
DPT	Differential air pressure transducer).		OPTION		5 x 1 mm ² (shielded)
OS HR/T	Outdoor sensor for enthalpic free cooling.				
AS HR/T	Remote ambient sensor for enthalpic free cooling.				

RETURN AND EXHAUST FAN CONNECTIONS

	020	025 > 040	45	055 > 085	100
Exhaust fan	3 x 1,5 mm ²			4 x 1,5 mm ²	
Return fan				4 x 1,5 mm ²	4 x 2,5 mm ²

FREE-COOLING CONNECTION

Version	
STD & DUAL SPLIT	5 x 1,5 mm ²
C50	7 x 1,5 mm ²

VOLTAGE OPERATING LIMITS: 342-462V

DC 40 THERMOSTAT, ELECTRICAL CONNECTION

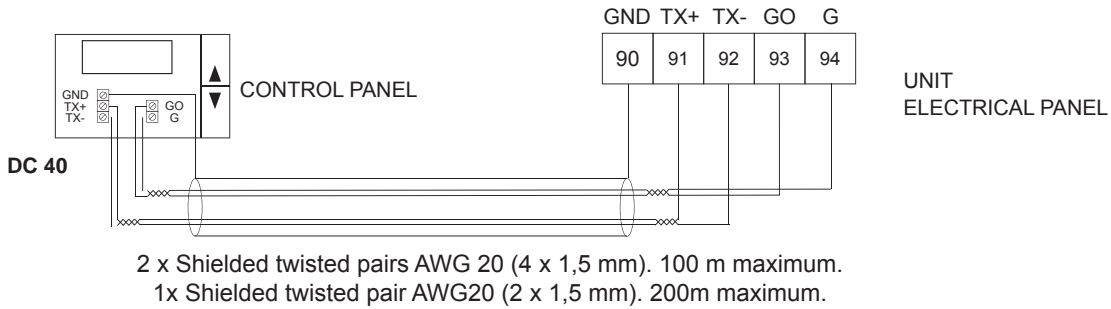

IMPORTANT

THE SHIELDED CONNECTION CABLE BETWEEN THE CONTROL PANEL AND THE UNIT MUST BE SEPARATE FROM ANY OTHER TYPE OF ELECTRICAL WIRING. CONNECT IT TO THE ELECTRICAL PANEL LOCATED IN THE OUTDOOR UNIT.

NOTES:

- For securing and connecting the Control Panel, consult the Control Panel manual supplied with the unit.
- Connection between DC40 and unit must be done with shielded twisted pair cables (where the screens are connected to the control panel and to the unit electrical panel)
- The Tx+ and Tx- polarity must strictly comply with the electrical diagram supplied with the unit.

TERMINAL COMFORT AND SERVICE CONNECTION (CONTROL CLIMATIC 50)

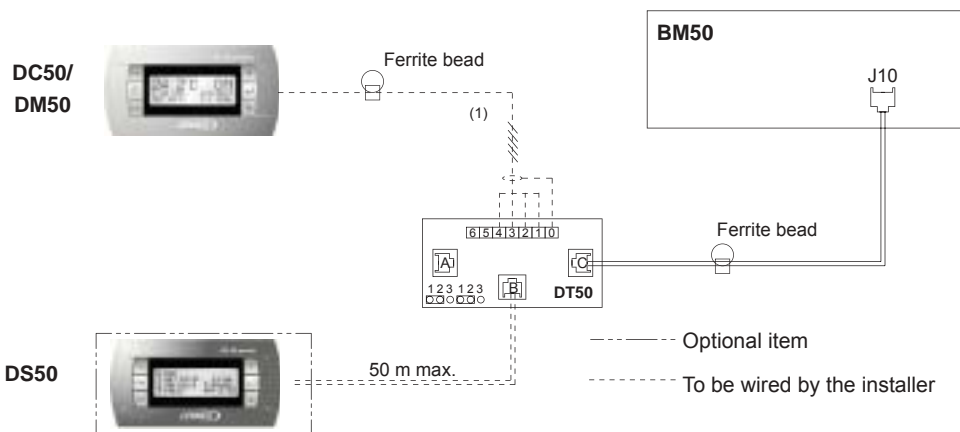

NOTE: Jumpers in the expansion module BE50 must be connected between 1 and 2 in order to make the power supply available to all connectors

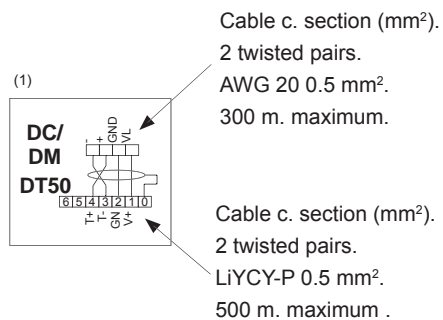

ELECTRICAL CONNECTION “REMOTE SIGNALS”

The electrical panel in all the range provides the following functions:

- Remote ON/OFF.
- One alarm signal.
- Winter/summer remote change.(Standard and D2 units).

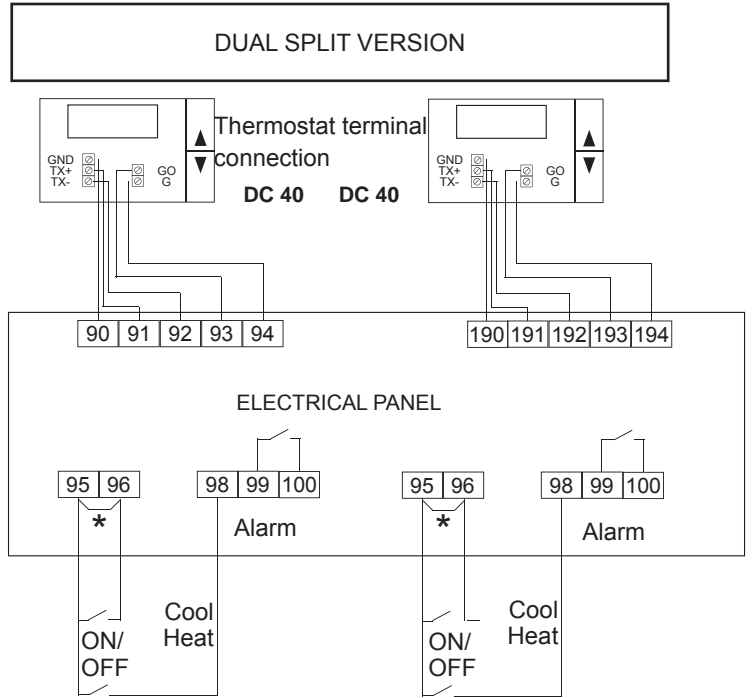
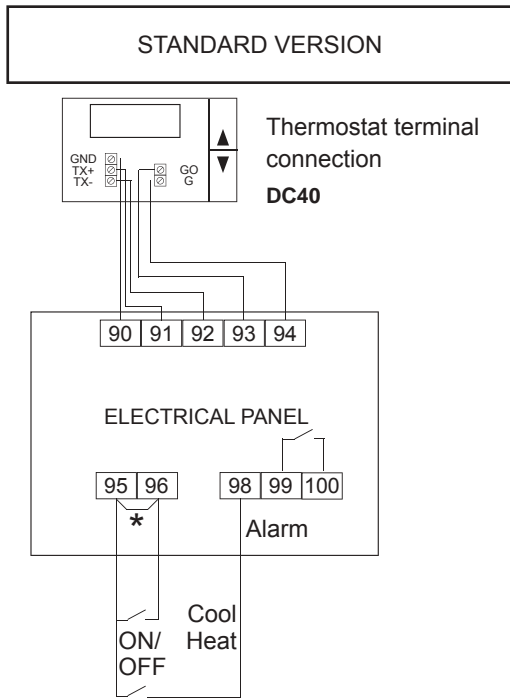

* Remove link for remote ON/OFF operation.

When C50 option

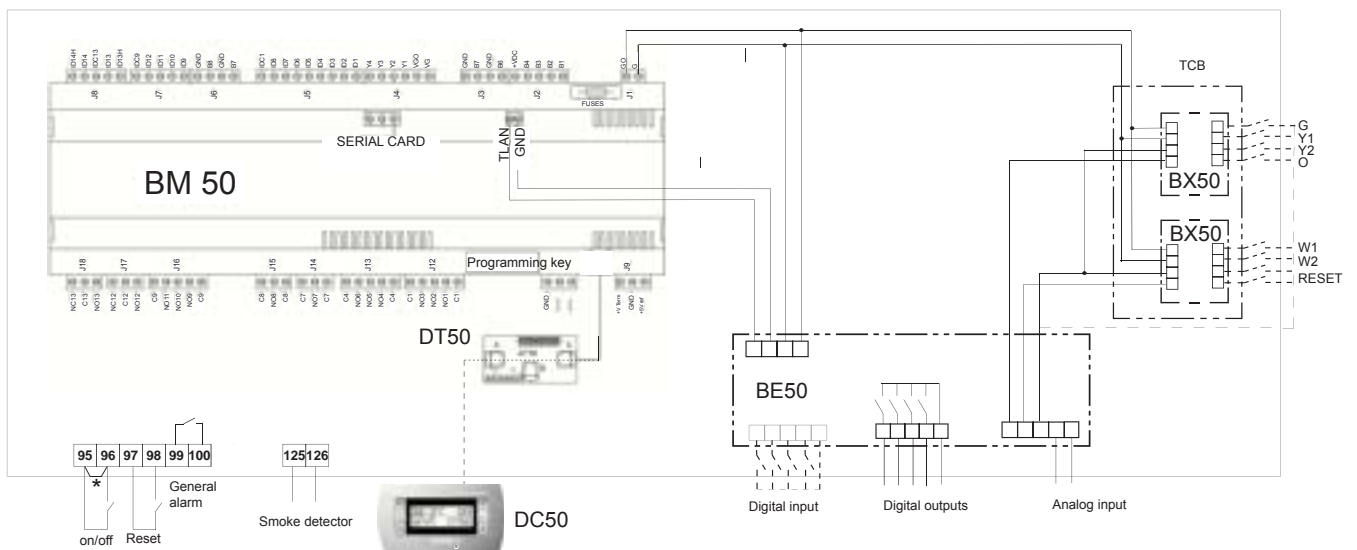

* Remove link for remote ON/OFF operation.

A BOX & B BOX **SIZES 20S/25S/30S & 35S/40S/45S**

SPLIT - STANDARD HORIZONTAL DISCHARGE

CONDENSING SECTION

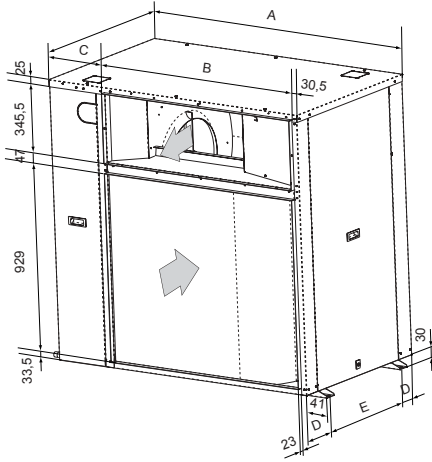

AIR TREATMENT SECTION

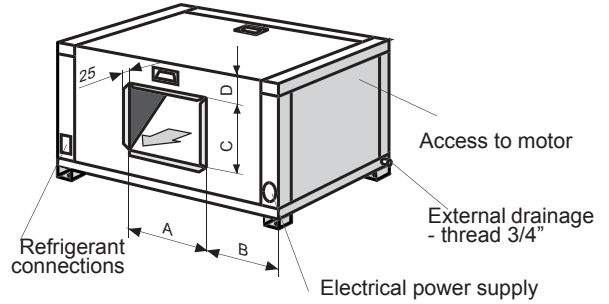

MODELS	A BOX	B BOX
	020 - 025 - 030 S	035S - 040S - 045S
A	1194	1445
B	1000	1093
C	163,5	321,5
D	102,5	133
E	540	600

MODELS	A BOX	B BOX
	020 - 025 - 030 S	035S - 040S - 045S
A	400	534
B	387	455,5
C	346	467
D	190	188,5

SPLIT - OPTIONAL VERTICAL DISCHARGE

CONDENSING SECTION

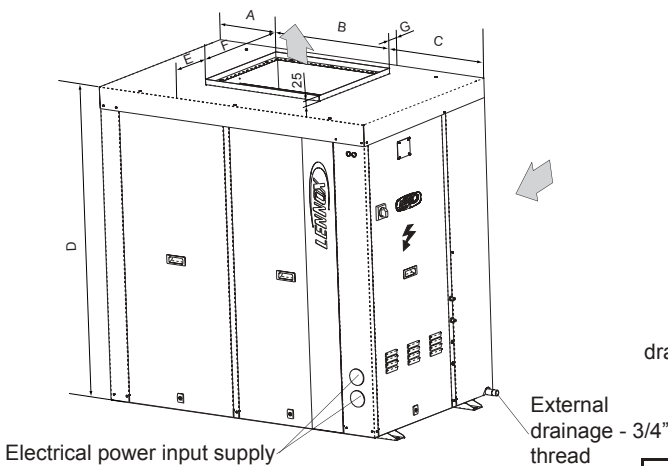

AIR TREATMENT SECTION

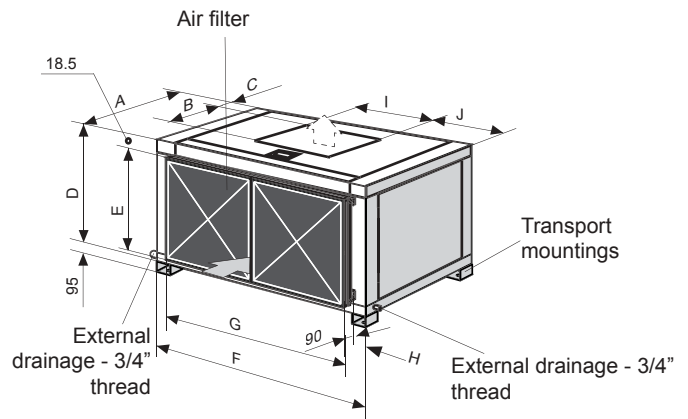

MODELS	A BOX	B BOX
	020 - 025 - 030 S	035S - 040S - 045S
A	371,5	420
B	564	622
C	288,5	403
D	1410	1500
E	204,5	252,5
F	467	543
G	77,5	74,5

MODELS	A BOX	B BOX
	020 - 025 - 030 S	035S - 040S - 045S
A	750	870
B	346	470
C	191	3
D	645	740
E	603	695
F	1195	1445
G	1005	1260
H	104	140
I	400	534
J	407	455,5

A BOX & B BOX

SIZES 20S/25S/30S & 35S/40S/45S

MONOBLOC - STANDARD VERTICAL DISCHARGE

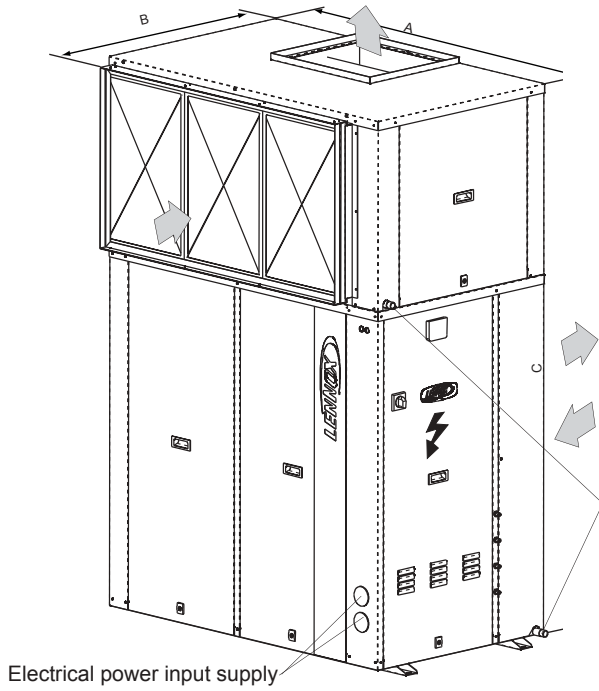

MODELS	A BOX	B BOX
	020 - 025 - 030 S	035S - 040S - 045D
A	1194	1445
B	840	960
C	2025	2170

MONOBLOC - OPTIONAL HORIZONTAL DISCHARGE

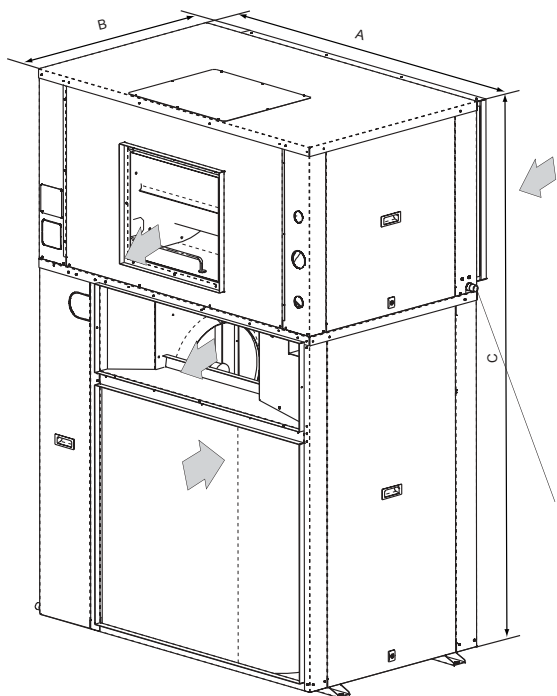

MODELS	A BOX	B BOX
	020 - 025 - 030 S	035S - 040S - 045D
A	1194	1445
B	840	960
C	2055	2145

C BOX **SIZES 55D/70D/85D**

STANDARD HORIZONTAL DISCHARGE

CONDENSING SECTION

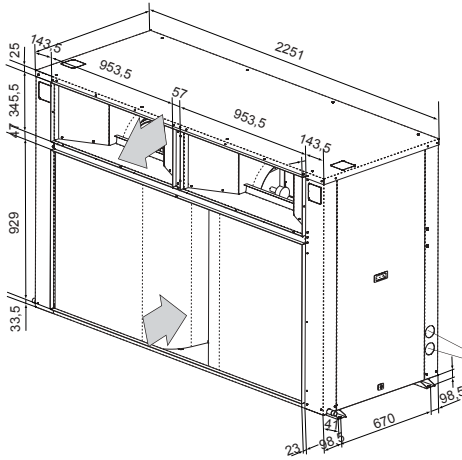

AIR TREATMENT SECTION

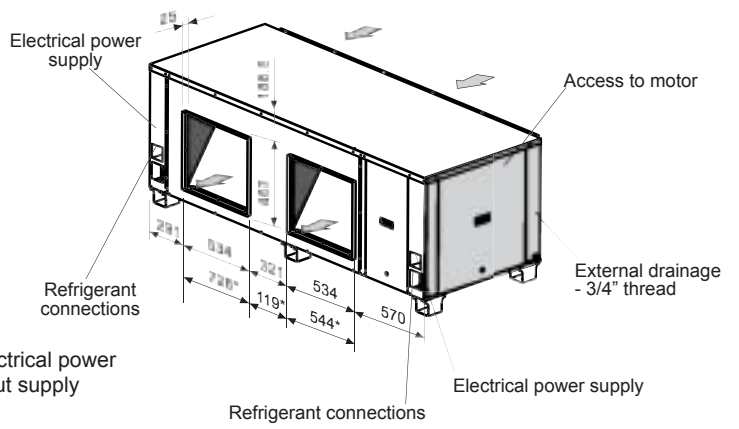

* For HP2 & HP3

OPTIONAL VERTICAL DISCHARGE

CONDENSING SECTION

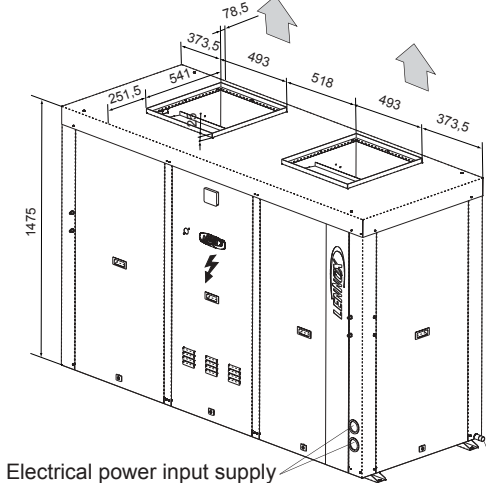

AIR TREATMENT SECTION

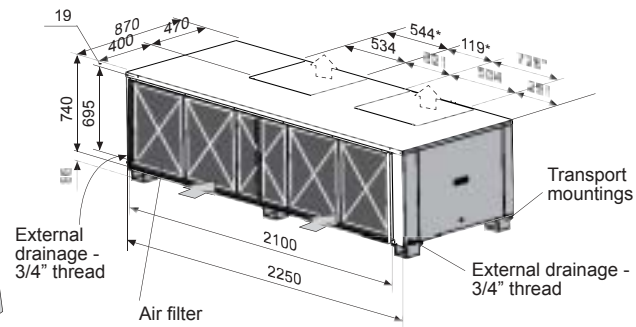

* For HP2 & HP3

MONOBLOC - STANDARD VERTICAL DISCHARGE

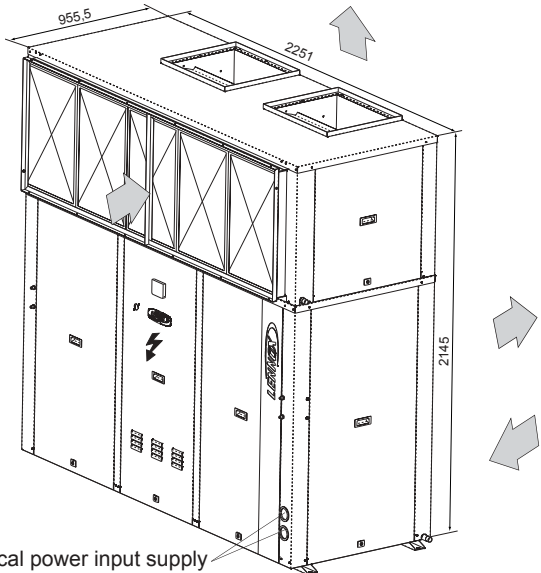

MONOBLOC - OPTIONAL HORIZONTAL DISCHARGE

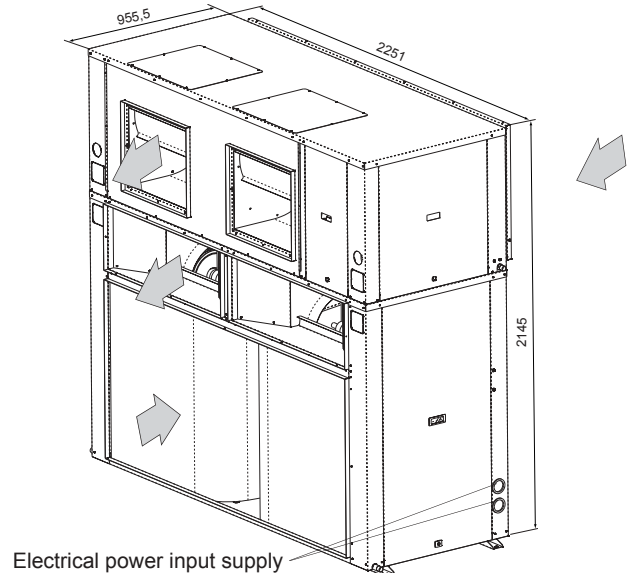

D BOX

SIZES 100D

STANDARD HORIZONTAL DISCHARGE

CONDENSING SECTION

AIR TREATMENT SECTION

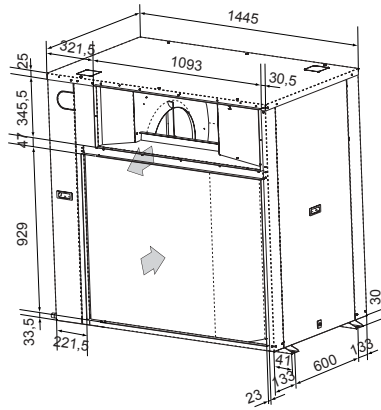
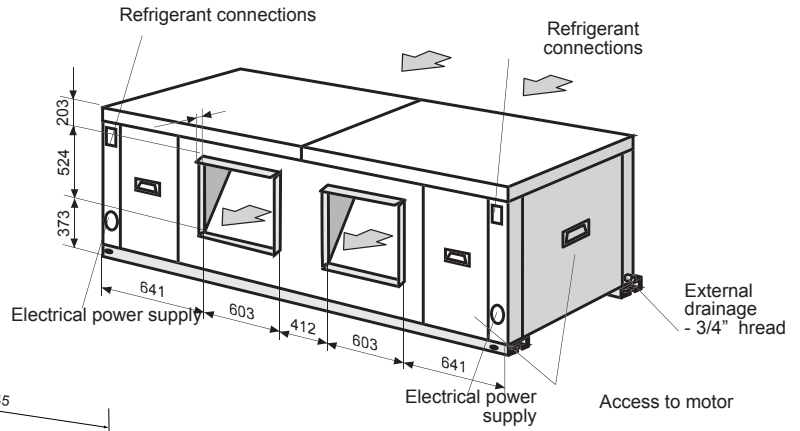
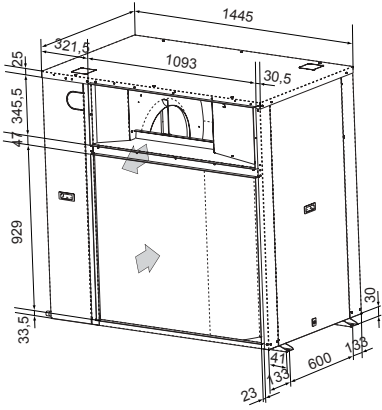

OPTIONAL VERTICAL DISCHARGE

CONDENSING SECTION

AIR TREATMENT SECTION

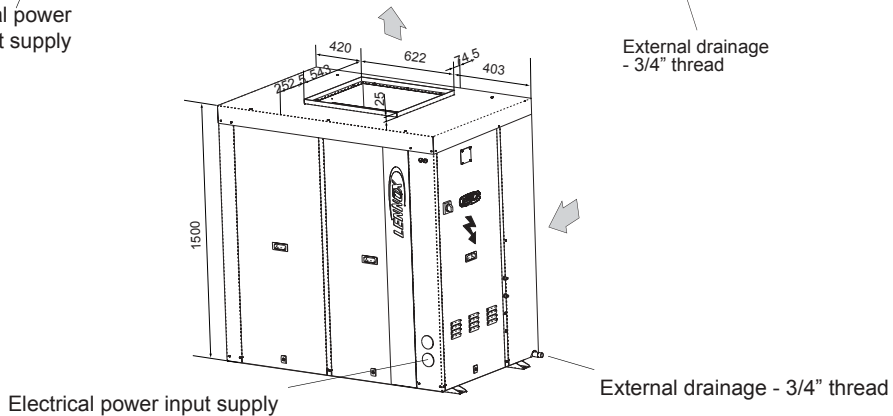
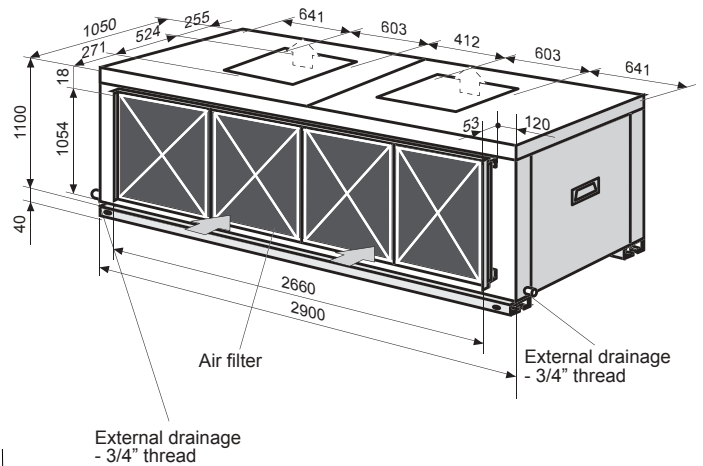
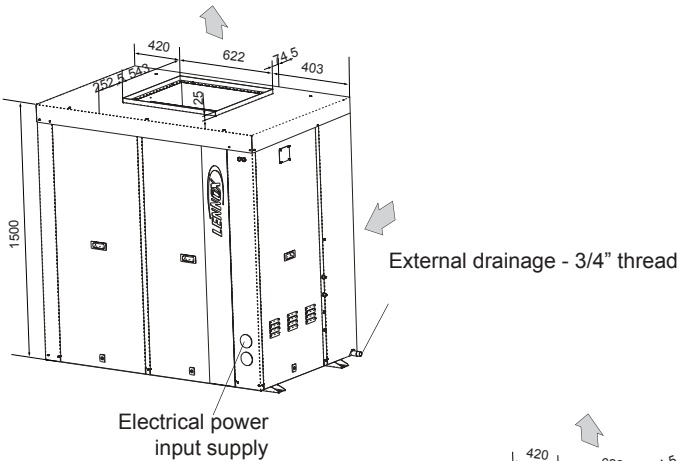

ECONOMIZER + EXHAUST FANS

A BOX & B BOX

020S/025S/030S/035S/040S/045D

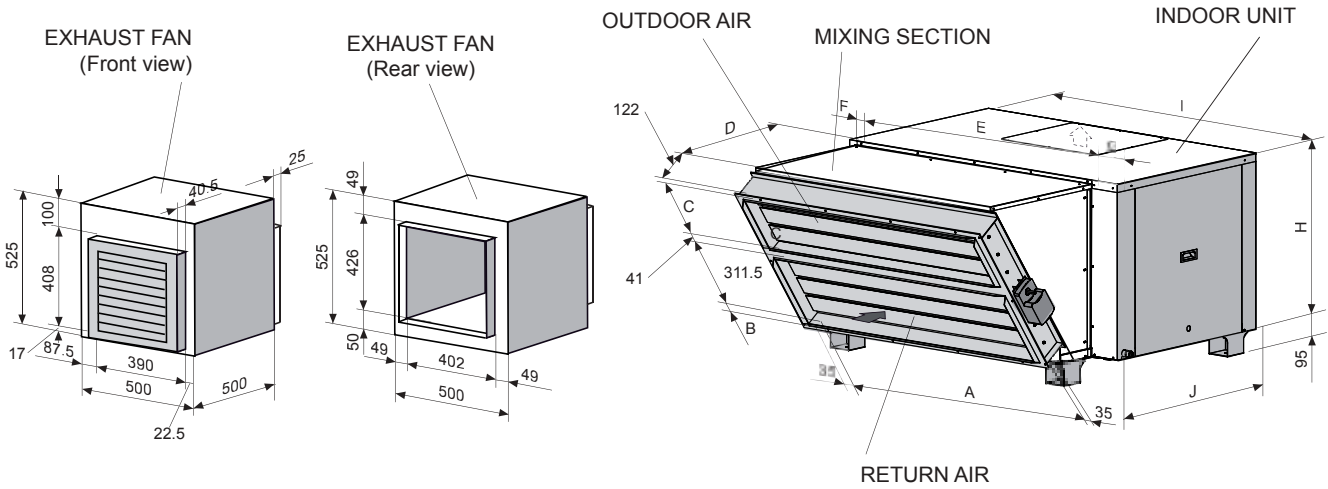

The damper position may be different from that shown in the illustration. See drawings.

MODELS	A BOX	B BOX	MODELS	A BOX	B BOX
	020 - 025 - 030 S	035S - 040S - 045S		020 - 025 - 030 S	035S - 040S - 045S
A	1000	1250	F	80,5	41
B	25	19,5	G	100,5	136
C	147,5	229,5	H	645	740
D	648	642	I	1195	1445
E	1013	1268	J	750	870

C BOX

055D/070D/085D

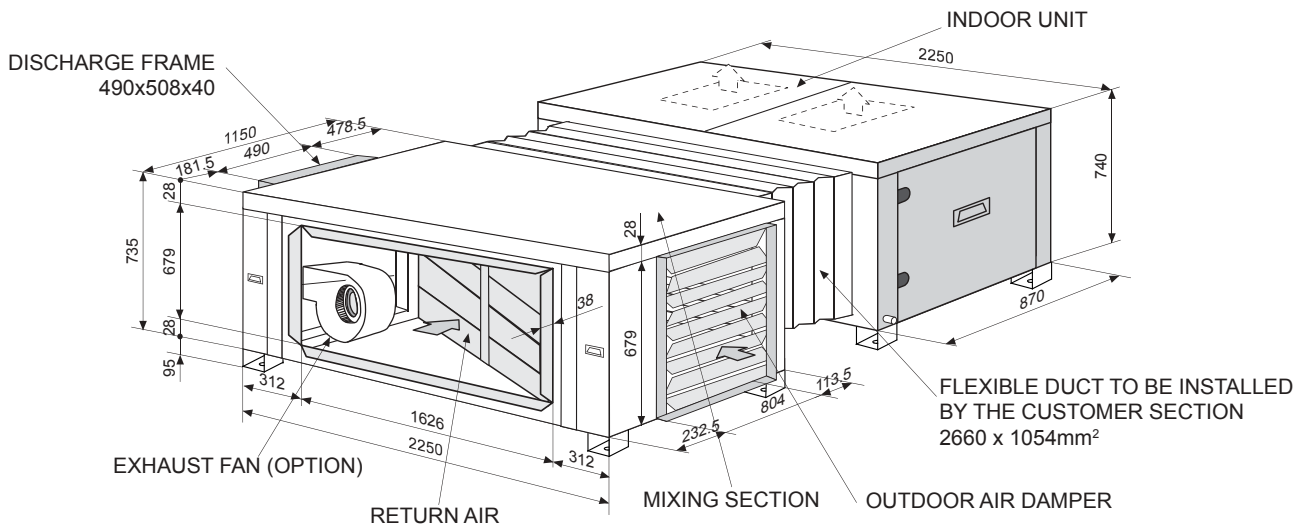

It is possible to include an exhaust fan with free cooling without return fan.

ECONOMIZER + EXHAUST FANS

D BOX

100D

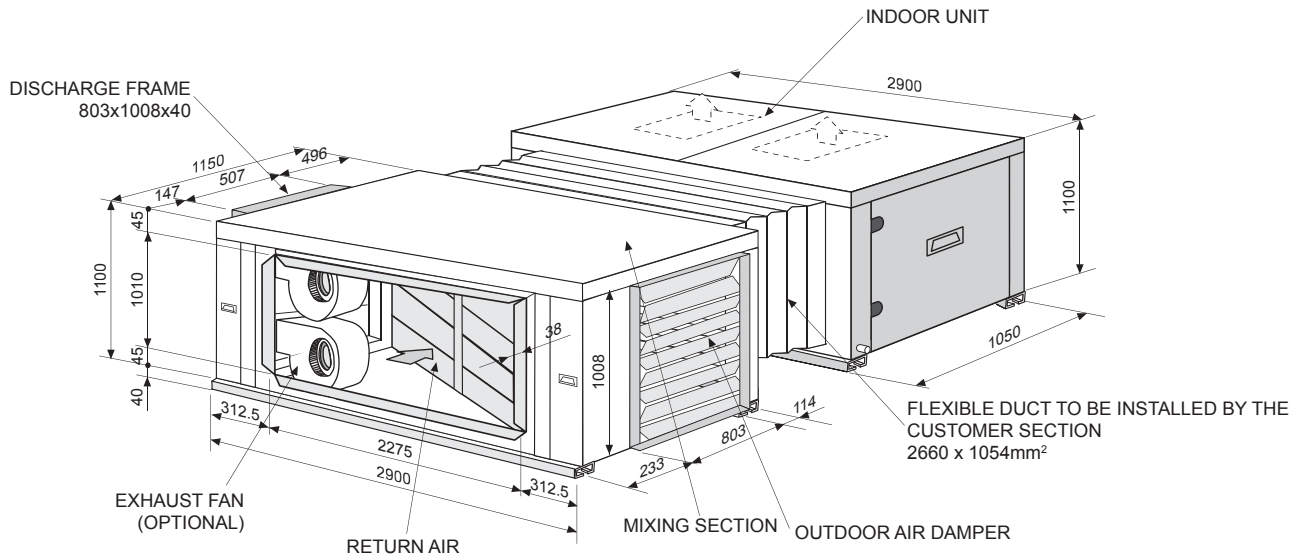

RETURN FAN MODULE

055D/070D/085D/100D

MODELS	055D/070D/085D	100D
A	2250	2571
B	28	45
C	28	45
D	650	700
E	1626	2275
F	312	148
G	312	148
H	735	1100
I	679	1010
J	95	40

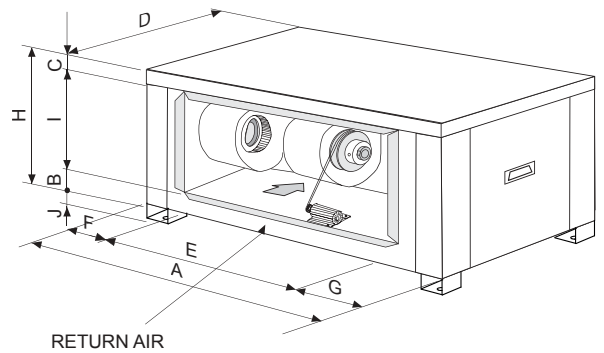

CLEARANCES

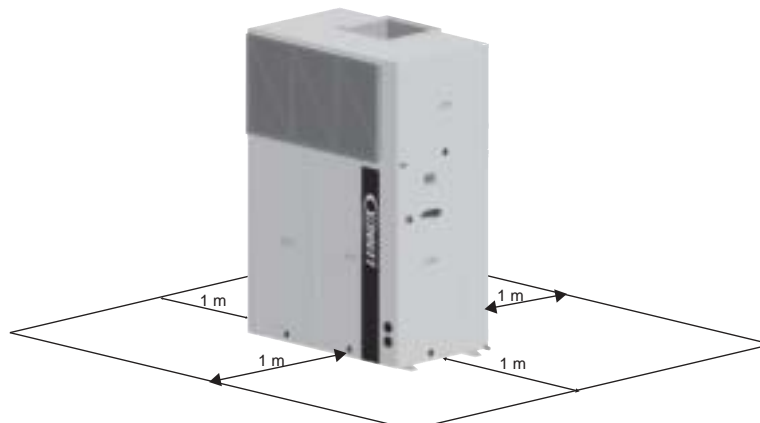

REMINDER - UNIT CONFIGURATIONS

COMPACTAIR™		20S	25S	30S	35S	40S	45D	55D	70D	85D	100D
Monobloc	CMC / CMH										
Split	CSC/CSH - CIC/CIH										
Dual Split	CSC / CSH - 2x CIC/CIH							2x30S	2x35S	2x40S	

MONOBLOC UNIT

Table 6.1

COMPACTAIR™	CMC CMH	20 S	25 S	30 S	35 S	40 S	45 D	55 D	70 D	85 D
Standard unit - CMC - Cooling only	kg	371	407	418	510	533	623	779	824	876
Standard unit - CMH Heat pump	kg	376	412	424	516	539	630	785	831	883
Air sock control	kg	2	2	2	2	2	2	2	3	3
Electrical heater	kg	10	10	10	10	10	20	20	20	30
Economizer	kg	50	50	50	75	75	75	165	165	165
Hot water coil	kg	10	10	10	12	16	20	20	24	30
High pressure fan motor indoor - HP1	kg	6.5	3	3	5	0	3	3	3	13
High pressure fan motor indoor - HP2	kg	6,5	3	8	8	3	6	6	16	21
High pressure fan motor indoor - HP3	kg	9,5	8	11	8	6	6	19	24	21
Exhaust fan	kg	25	25	25	28	28	28	37	37	37
Low noise	kg	2	2	2	2	2	3	4	4	7
High filtration level G4 prefiltrrer / F7 filtration	kg	6	6	6	9	9	9	14	14	14

CONDENSING UNIT

Table 6.2a

COMPACTAIR™ CSC/CSH & CDC/CDH		20 S	25 S	30 S	35 S	40 S	45 D	55 D	70 D	85 D	100 D
CSC/CDC - Cooling only	kg	257	290	297	352	365	443	524	549	581	865
CSH/CDH - Heat pump	kg	262	295	302	357	370	448	529	554	586	870
Low noise	kg	2	2	2	2	2	3	4	4	7	5
Long distance refrigerant connection (65 m)	kg	2	6	6	4	4	12	12	8	8	12
Refrigerant precharge* - Cooling only	kg	5,5	5,5	6,2	8,0	8,3	10,4	12,9	16,0	18,6	23,4
Refrigerant precharge* - Heat pump	kg	5,8	6,1	6,9	8,9	9,2	11,5	14,3	17,7	20,7	25,8

AIR TREATMENT SECTION

Table 6.2b













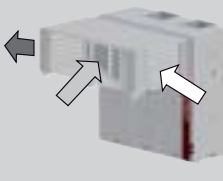

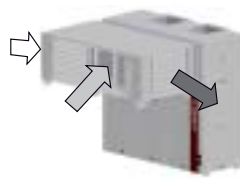

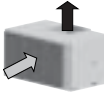
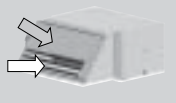

COMPACTAIR™	CIC CIH	20	25	30	35	40 S	45 D	55 D	70 D	85 D	100 D
Air treatment section	kg	108	111	115	150	160	170	242	259	276	470
Air sock control	kg	2	2	2	2	2	2	2	3	3	3
Electrical heater	kg	10	10	10	10	10	20	20	20	30	45
Economizer	kg	50	50	50	75	75	75	165	165	165	190
Hot water coil	kg	10	10	10	12	16	20	20	24	30	40
High pressure fan motor indoor - HP1	kg	6.5	3	3	5	0	3	3	3	13	13
High pressure fan motor indoor - HP2	kg	6,5	3	8	8	3	6	6	16	21	27
High pressure fan motor indoor - HP3	kg	9,5	8	11	8	6	6	19	24	21	27
Exhaust fan	kg	25	25	25	28	28	28	37	37	37	65
High filtration level G4 prefiltrrer / F7 filtration	kg	6	6	6	9	9	9	14	14	14	23

Operating weights

* Available as an option

MONOBLOC

Table 7.1

	Standard	Optional	With economizer standard configuration		With economizer configuration as option	
			A & B Box	C Box	A & B Box	C Box
			20S - 45D	55D - 85D	20S - 45D	55D - 85D
Monobloc	 Upflow supply	 Horizontal supply	 Fresh air bottom Return air above	 Fresh air right Exhaust air left	 Position front	 Fresh air left Exhaust air right
					 Fresh air above Return air bottom	
					 Position front	
Air treatment section Split & Dual			A & B Box	C Box	A & B Box	C Box
			Split 20S - 45D Dual 55D - 85D	Split 55D - 100D	Split 20S - 45D Dual 55D - 85D	Split 55D - 100D
	 Horizontal supply	 Upflow supply	 Fresh air bottom Return air above	 Fresh air right Exhaust air left	 Fresh air above Return air bottom	 Fresh air left Exhaust air right
Condensing unit Split & Dual		 Vertical discharge	 Fresh air  Exhaust air  Return air  Supply air			



● **Direct Sales Offices:**

BELGIUM AND LUXEMBOURG

☎ + 32 3 633 3045

✉ info.be@lennox europe.com

CZECH REPUBLIC

☎ + 420 2 510 88 711

✉ info.cz@lennox europe.com

FRANCE

☎ +33 1 64 76 23 23

✉ info.fr@lennox europe.com

GERMANY

☎ + 49 69 42 09 79 0

✉ info.de@lennox europe.com

NETHERLANDS

☎ + 31 332 471 800

✉ info.nl@lennox europe.com

POLAND

☎ +48 22 58 48 610

✉ info.pl@lennox europe.com

PORTUGAL

☎ +351 229 066 050

✉ info.pt@lennox europe.com

RUSSIA

☎ +7 495 626 56 53

✉ info.ru@lennox europe.com

SLOVAKIA

☎ +421 2 58 31 83 12

✉ info.sk@lennox europe.com

SPAIN

☎ +34 91 540 18 10

✉ info.sp@lennox europe.com

UKRAINE

☎ +380 44 461 87 79

✉ info.ua@lennox europe.com

UNITED KINGDOM AND IRELAND

☎ +44 1604 669 100

✉ info.uk@lennox europe.com

● **Distributors and Agents**

Algeria, Austria, Belarus, Botswana, Bulgaria, Cyprus, Denmark, Estonia, Finland, Georgia, Greece, Hungary, Israel, Italy, Kazakhstan, Latvia, Lebanon, Lithuania, Morocco, Near East, Norway, Romania, Serbia, Slovenia, Sweden, Switzerland, Tunisia, Turkey

LENNOX DISTRIBUTION

☎ +33.4.72.23.20.00

✉ info.dist@lennox europe.com



COMPACTAIR-AGU-1109-E

Due to Lennox's ongoing commitment to quality, the Specifications, Ratings and Dimensions are subject to change without notice and without incurring liability.

Improper installation, adjustment, alteration, service or maintenance can cause property damage or personal injury.

Installation and service must be performed by a qualified installer and servicing agency