

0 5 10 15 20 25 30 35 40 45 50 55 60 65 70 75 80 85 90 95

INDICE	
REGLETERO CONEXIONES ELECTRICAS TERMINAL STRIP BORNIER DE CONNEXION ELECTRIQUE KLEMLEISTE AANSLUITSTRIP	HOJA 1/9
CIRCUITO POTENCIA POWER CIRCUIT CIRCUIT DE PUISSANCE STROMKREIS HOOFDSTROOMCIRCUIT	HOJA 2/9
CIRCUITO MANIOBRA CONTROL CIRCUIT CIRCUIT DE CONTROL STEUERKREIS REGELCIRCUIT	HOJA 3-4/9
CONEXION OPCIONALES OPTIONS CONNEXIONS OPTIONNELS OPTIONEN / ZUBEHÖR OPTIES	HOJA 5..8/9
LEYENDA REFERENCIAS REFERENCES LEGEND REFERENCE DE LEGENDE LEGENDE VERKLARING LEGENDA	HOJA 9/9



ESQUEMA ELECTRICO
WIRING DIAGRAM
SCHEMA ELECTRIQUE
SCHALTPLAN

Elemento Opcional
Optional Element
Element optionnel
Optionales bauteil

A realizar por el instalador
To wire by the installer
A câbler par l'installateur
Verdrahtung durch den installateur

%
9

Lemnox Refrac S.A.

ESQUEMA ELECTRICO
ELECTRIC DIAGRAM

ANHM 52D
C50

4Z-33-415-657 48H
3N ~ 400V 50Hz + PE

0 5 10 15 20 25 30 35 40 45 50 55 60 65 70 75 80 85 90 95

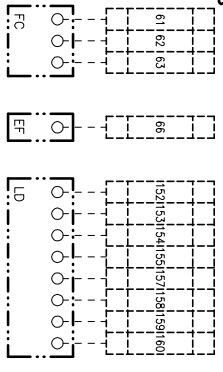

⚠ LA MANGUERA APANTALLADA DEBE CONECTARSE A TIERRA
 THE CABLE SCREEN MUST BE CONNECTED TO GROUND
 LA TRESSE DE BLINDAGE DOIT SE CONNECTER A LA TERRE
 DIE KABELABSCHIRMUNG MUSS GEEDET WERDEN

⚠ RETIRAR PUENTE SI SE MONTA ON/OFF REMOTO
 REMOVE LINK FOR REMOTE ON/OFF OPERATION
 RETIRER LE PONT EN CAS DE MARCHE/ARRET A DISTANCE
 ENTFERNE DIE VERBINDUNG ZUM EIN/AUS FERNSCHALTER

⚠ ESTAS BORNAS SOLAMENTE SE INCLUYEN CON SU OPCIONAL
 THESE TERMINALS ARE ONLY INCLUDED WITH ITS OPTIONAL
 CES CONTACTS SONT INSTALLEES SEULEMENT SI ON DEMANDE CHOISIT L'OPTIONAL
 DIESE ANSCHLUSSKLEMMEN SIND NUR MIT ZUBEHÖR VERFÜGBAR IHREM OPTIONAL

VER MANUAL INSTALACION
 SEE INSTALLATION MANUAL (IOM)
 VOIR LE MANUEL D'INSTALLATION
 SIEHE INSTALLATIONSHANDBUCH (IOM)

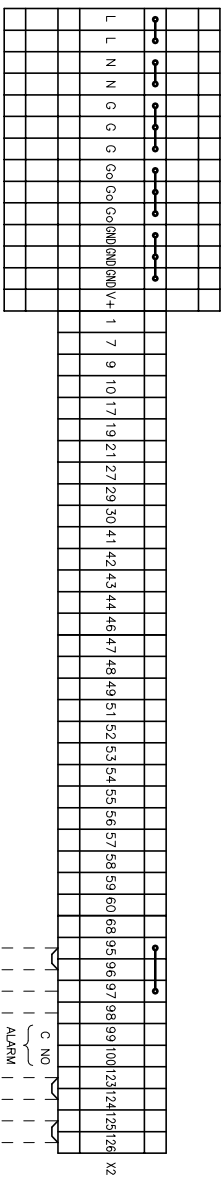

⚠ ON/OFF REMOTO ON/OFF
 REMOTE ON/OFF
 RESET
 RESET
 ALARMA DAD
 DAD ALARM
 SEÑAL DAD
 SIGNAL DAD

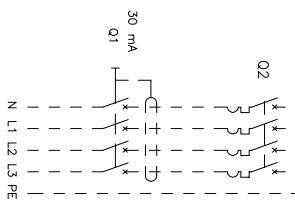
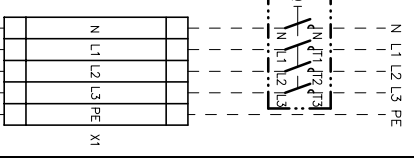

3N~400V 50Hz+PE

ALIMENTACION
 POWER SUPPLY
 ALIMENTATION ELECTRIQUE
 STROMZULEITUNG

Elemento Opcional
 Optional Element
 Element optionnel
 Optionales bauteil

A realizar por el instalador
 To wire by the installer
 A câbler par l'installateur
 Verdrahtung durch den installateur

1/9
 Lennox Refrac S.A.

ESQUEMA ELECTRICO
 ELECTRIC DIAGRAM

**ANHM 52D
 C50**

4Z-33-415-657 48H
 3N ~ 400V 50Hz + PE

0 5 10 15 20 25 30 35 40 45 50 55 60 65 70 75 80 85 90 95

3N~400V 50Hz+PE
 N L1 L2 L3 PE
 VER MANUAL INSTALACION
 SEE INSTALLATION MANUAL (OM)
 VOIR LE MANUEL D'INSTALLATION
 SIEHE INSTALLATIONSHANDBUCH (OM)

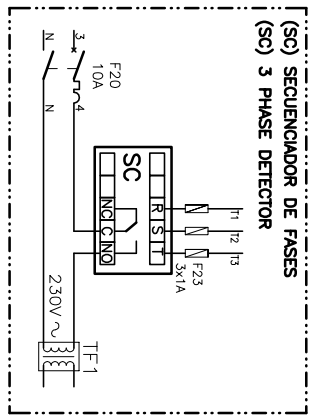
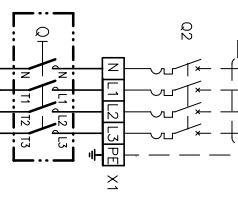

7.5kW 1S	Im(CC) d(LRA)	10.8A
F		1.6A
11kW 1S	Im(CC) d(LRA)	15.9A
F		2.0A
15kW 1S	Im(CC) d(LRA)	21.7A
F		2.5A

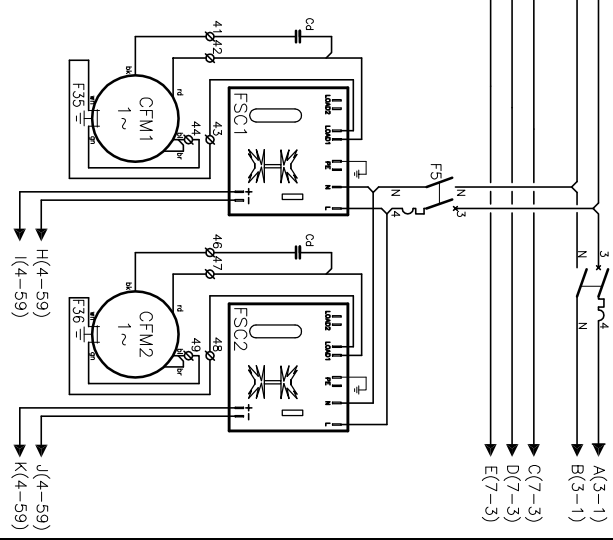
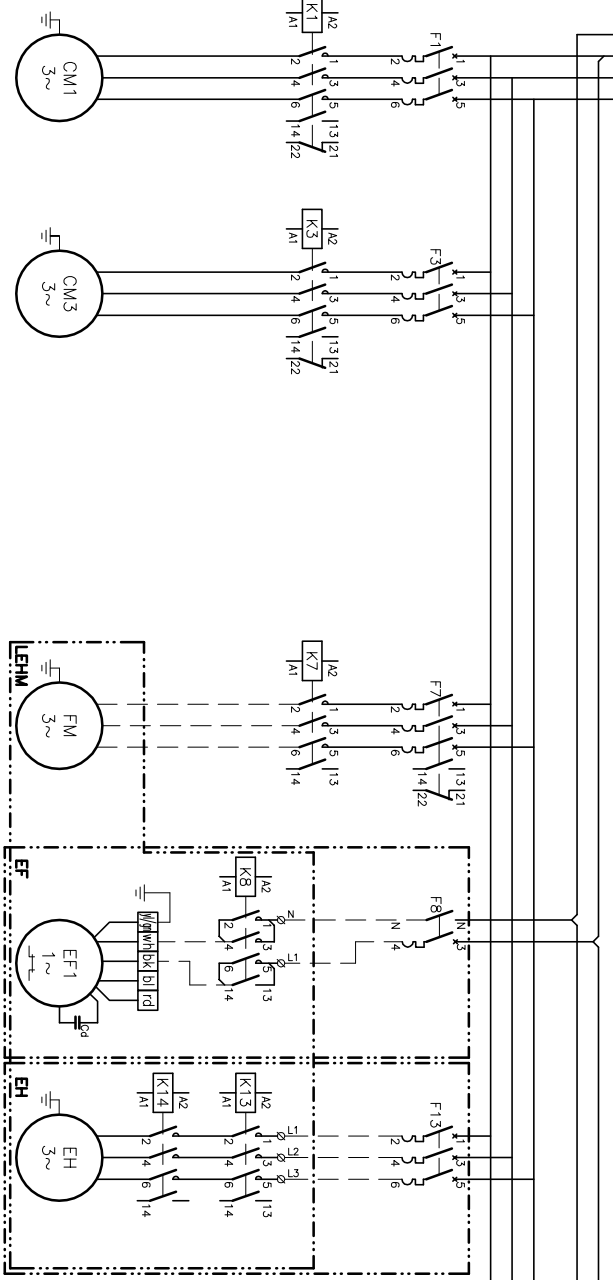

- CIRCUITO MANIOBRA
- CONTROL CIRCUIT
- CIRCUIT DE CONTROL
- STEUERKREIS

ANHM 52D	Im(CC)	21A	21A	STD	4.8A	6.48A	HIGH	6.8A
	d(LRA)	111A	111A		26.4A	35.6A		
52D	F	25A	25A	4.6, 3A	6.10A			

Elemento Opcional
 Optional Element
 Element optionnel
 Optionales bauteil

A realizar por el instalador
 To wire by the installer
 A cobler par l'installateur
 Verdrahtung durch den installateur

2/9	Lemnox Refrac S.A.	ESQUEMA ELECTRICO ELECTRIC DIAGRAM	ANHM 52D C50	4Z-33-415-657 48H 3N ~ 400V 50Hz + PE
-----	--------------------	---------------------------------------	-----------------	--

0 5 10 15 20 25 30 35 40 45 50 55 60 65 70 75 80 85 90 95

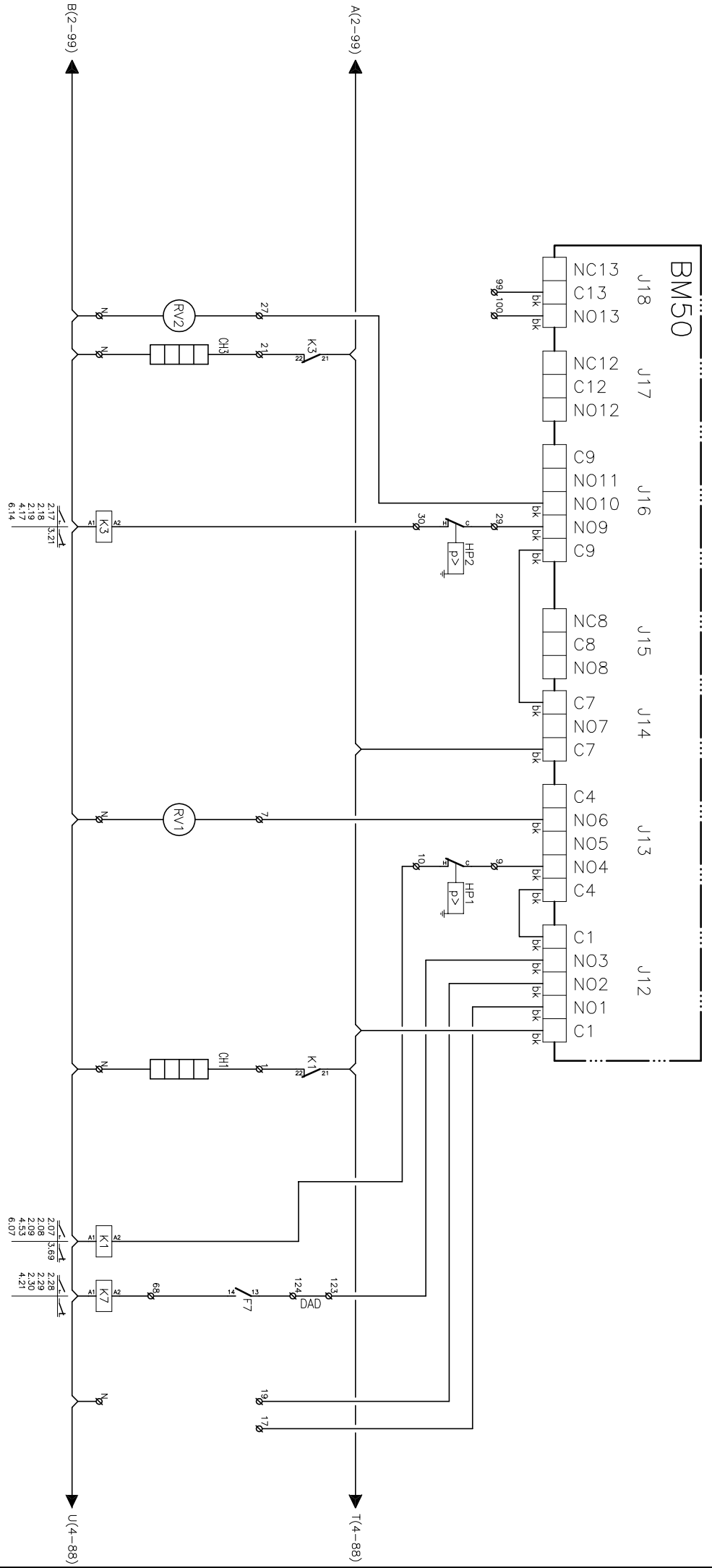

Elemento Opcional
 Optional Element
 Element optionnel
 Optionales bauteil

A realizar por el instalador
 To wire by the installer
 A câbler par l'installateur
 Verdrahtung durch den installateur

3/9	Lennox Refrac S.A.	ESQUEMA ELECTRICO ELECTRIC DIAGRAM	ANHM 52D C50	4Z-33-415-657 48H 3N ~ 400V 50Hz + PE
-----	--------------------	---------------------------------------	-----------------	--

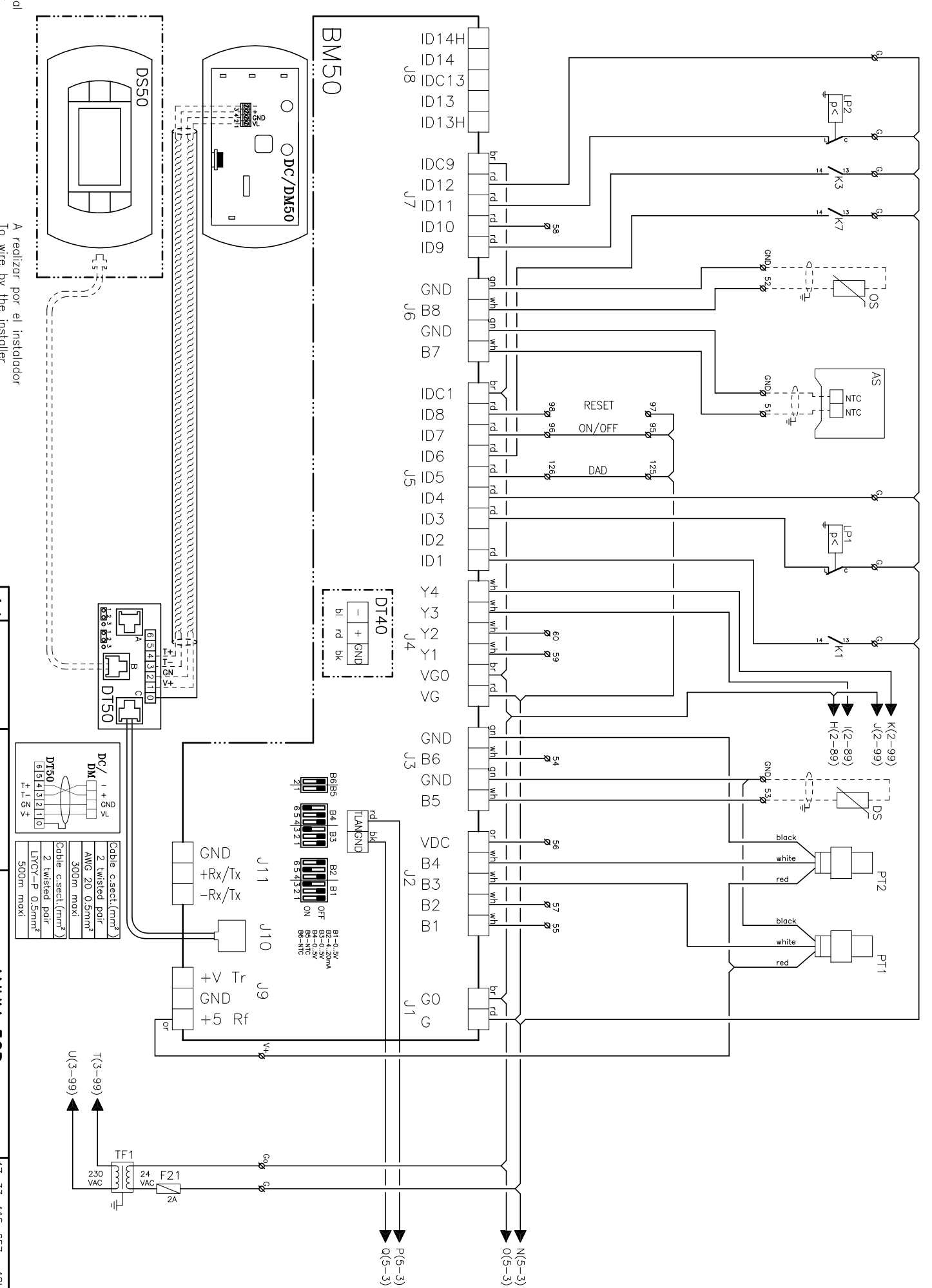

BM50

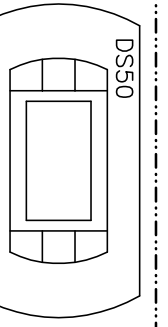
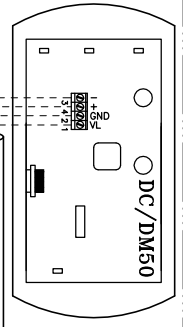

Elemento Opcional
 Optional Element
 Element optionel
 Optionales bauteil
 A realizar por el instalador
 To wire by the installer
 A cobler por l'instalador
 Verdrahtung durch den installateur
 Lennox Refrac S.A.
 ESQUEMA ELECTRICO
 ELECTRIC DIAGRAM
ANHM 52D
C50
 4Z-33-415-657 48H
 3N ~ 400V 50Hz + PE

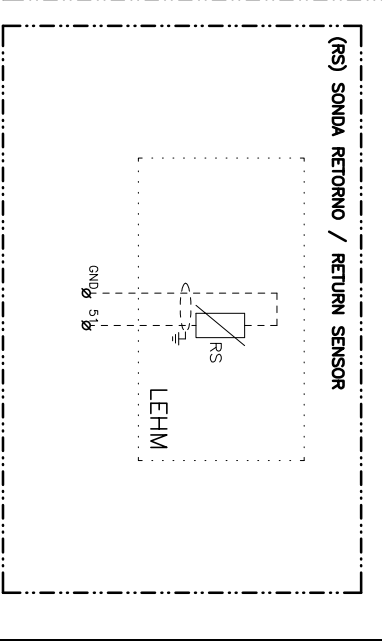
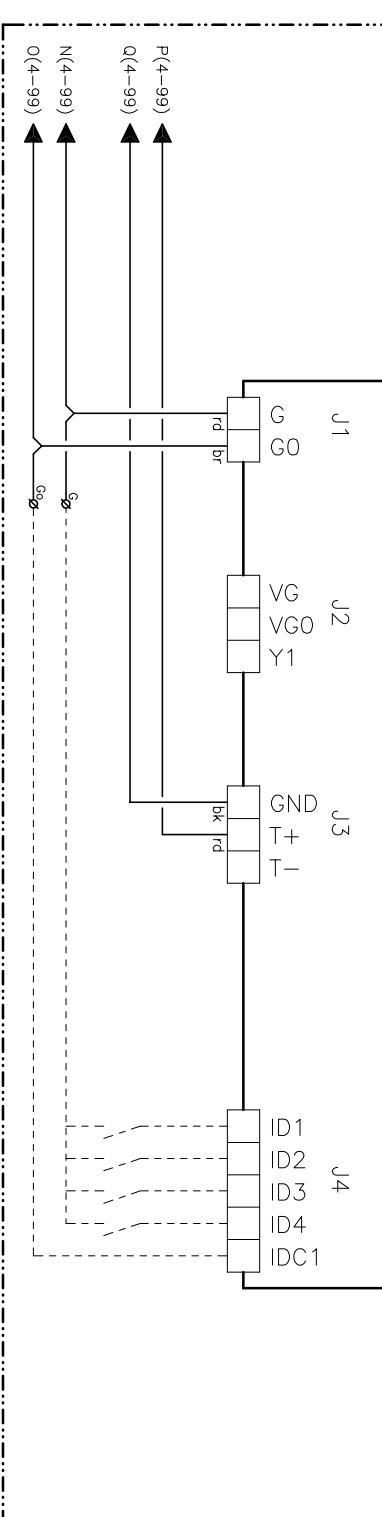
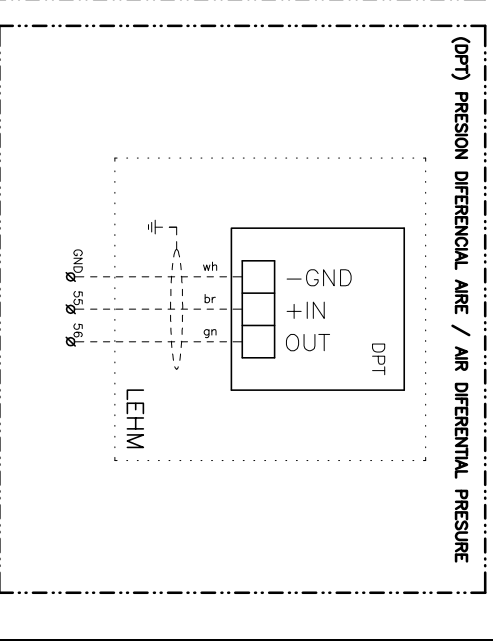
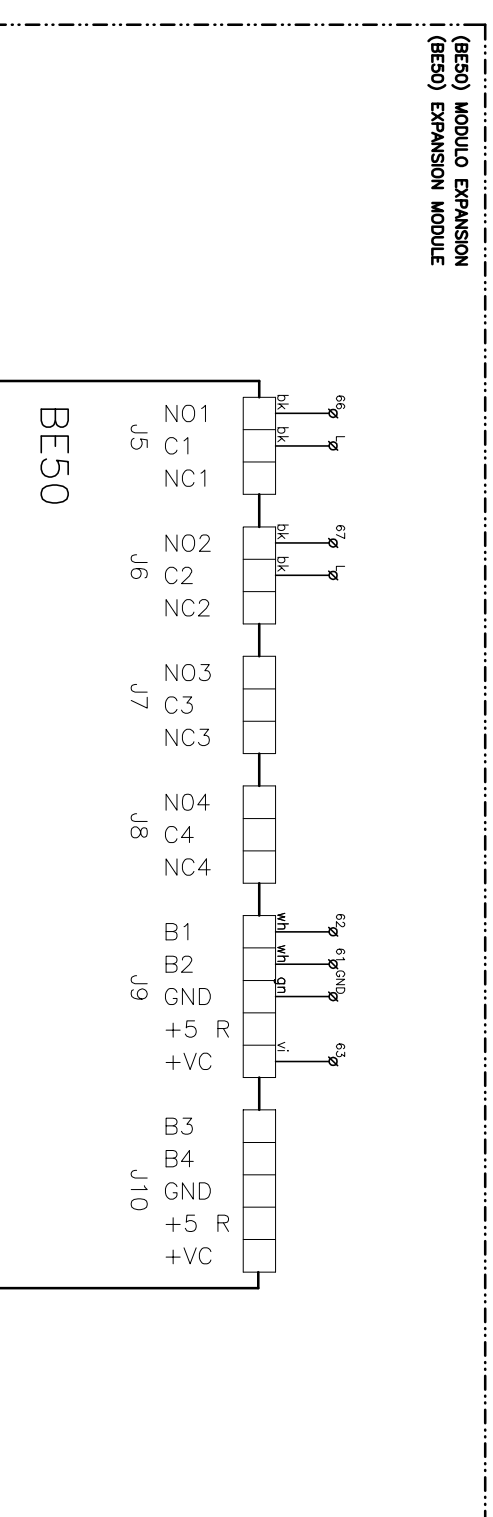
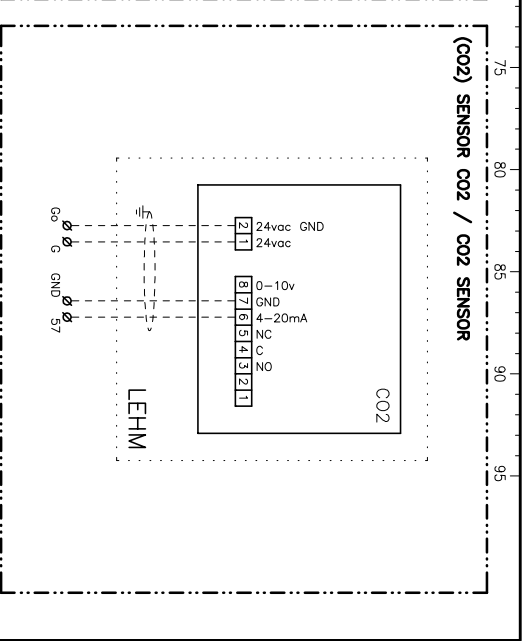
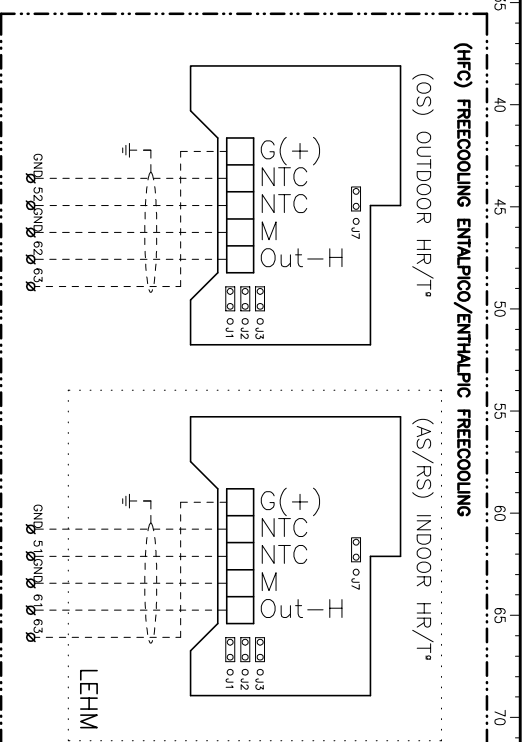
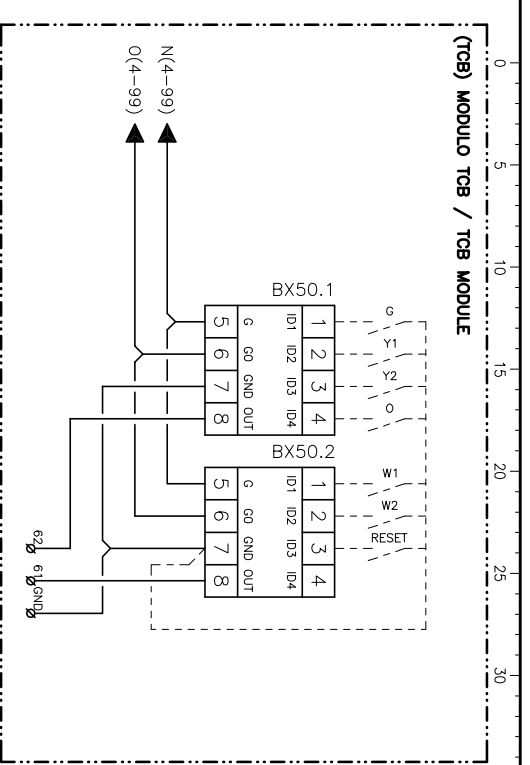

Elemento Opcional / Optional Element / Element optionel / Opcionales bauteil

A realizar por el instalador / To wire by the installer / A cobler por l'installateur / Verdrahtung durch den installateur

5/9	Lennox Refriger S.A.	ESQUEMA ELECTRICO / ELECTRIC DIAGRAM	ANHM 52D C50	4Z-33-415-657 48H 3N ~ 400V 50Hz + PE
-----	----------------------	--------------------------------------	--------------	--

(SFS) ARRANCADOR SUAVE/SOFT STARTER

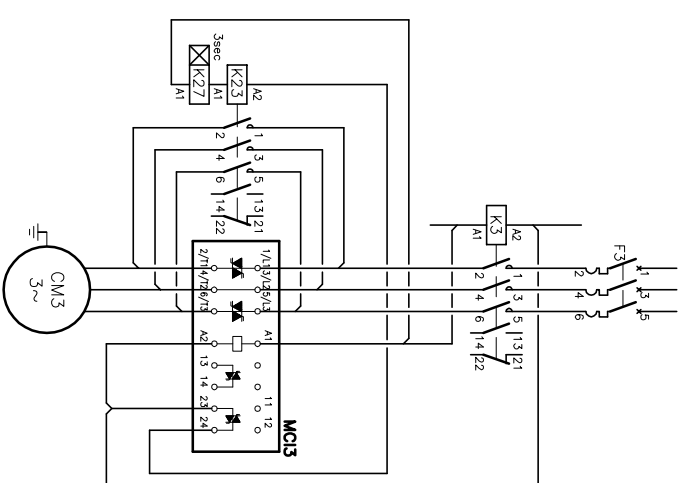
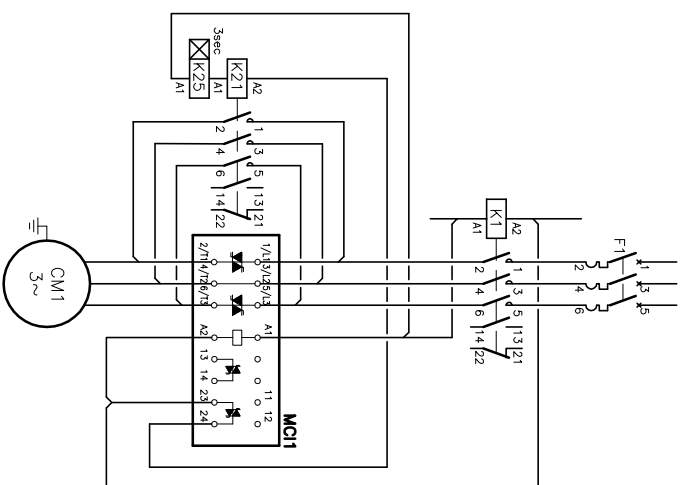

(LD) KIT LARGA DISTANCIA
(LD) KIT LONG DISTANCE

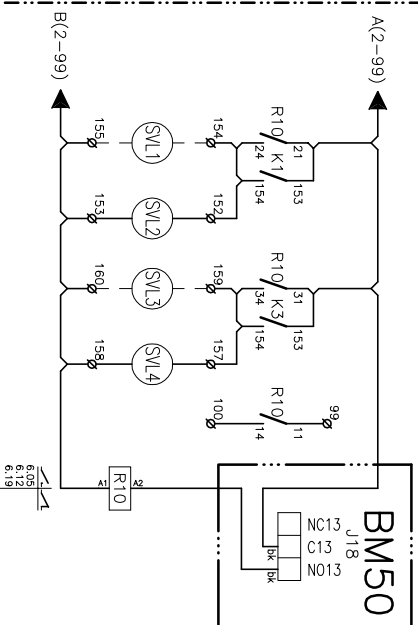

Elemento Opcional
Optional Element
Element optionnel
Optionales bauteil

A realizar por el instalador
To wire by the installer
A câbler par l'installateur
Verdrahtung durch den installateur

6/9

Lemnox Refrac S.A.

ESQUEMA ELECTRICO
ELECTRIC DIAGRAM

ANHM 52D
C50

4Z-33-415-657 48H
3N ~ 400V 50Hz + PE

(HWC) BAT. AGUA CALIENTE / HOT WATER COIL

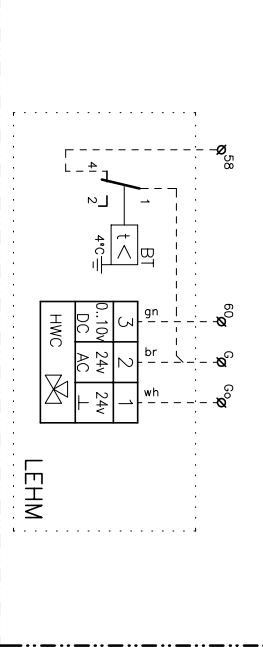

(EH) BATERIA ELECTRICA / ELECTRICAL HEATER

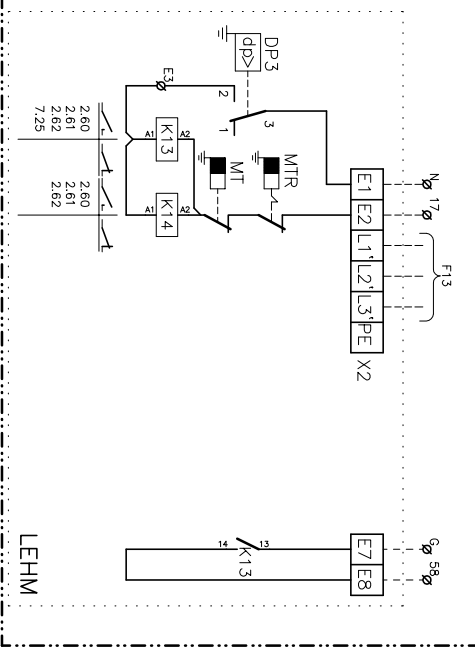

(HFC / FC) FREECOOLING
(HFC / FC) FREECOOLING

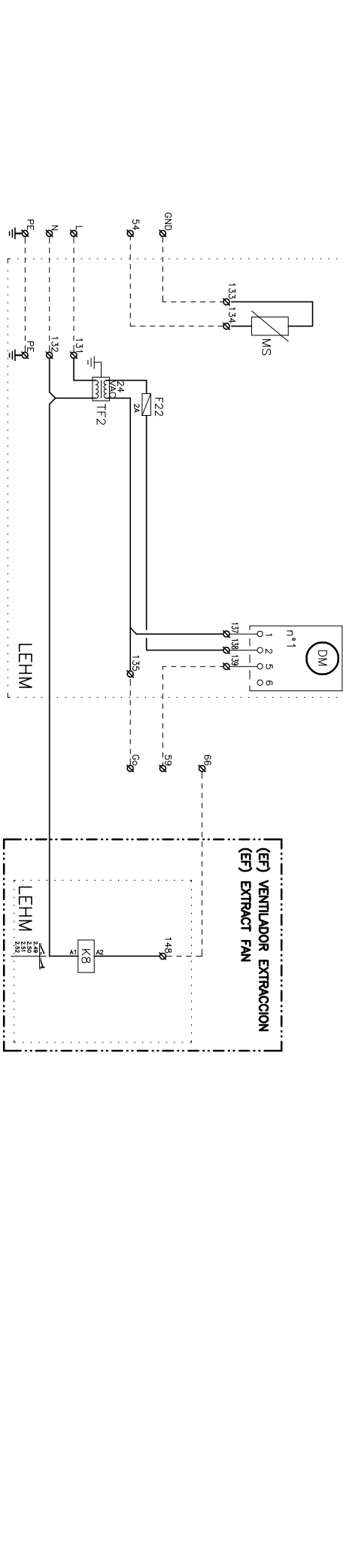

Elemento Opcional
Optional Element
Element optionnel
Optionales bauteil

A realizar por el instalador
To wire by the installer
A cobler par l'installateur
Verdrahtung durch den installateur

7/9

Lennox Refrac S.A.

ESQUEMA ELECTRICO
ELECTRIC DIAGRAM

ANHM 52D
C50

4Z-33-415-657 48H
3N ~ 400V 50Hz + PE

0 5 10 15 20 25 30 35 40 45 50 55 60 65 70 75 80 85 90 95

(DAD) CONTROL DE DETECCION DE HUMOS
(DAD) SMOKE DETECTION CONTROL

UNIDAD INTERIOR / INDOOR UNIT
 UNITE INTERIEUR / INNENGERÄT

CUADRO PRINCIPAL/MAIN ELECTRICAL BOARD
 COFFRET ELECTRIQUE/HAUPTPLATINE

RETIRAR PUENTE SI SE MONTA DAD
 REMOVE LINK FOR DAD OPERATION
 RETIRER LE POND SIL Y A DAD
 ENTFERNEN DIE VERBINDUNG ZUM DAD

PARO UNIDAD
 SHUT-DOWN UNIT
 ARRÊT UNITE
 GÉRAT ABSCHALTEN

SEÑAL DE ALARMA
 ALARM SIGNAL
 SIGNALISATION D'ALARME
 ALARMMELDUNG

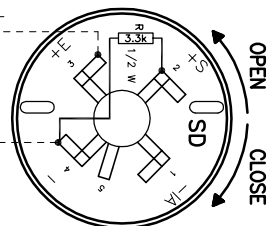
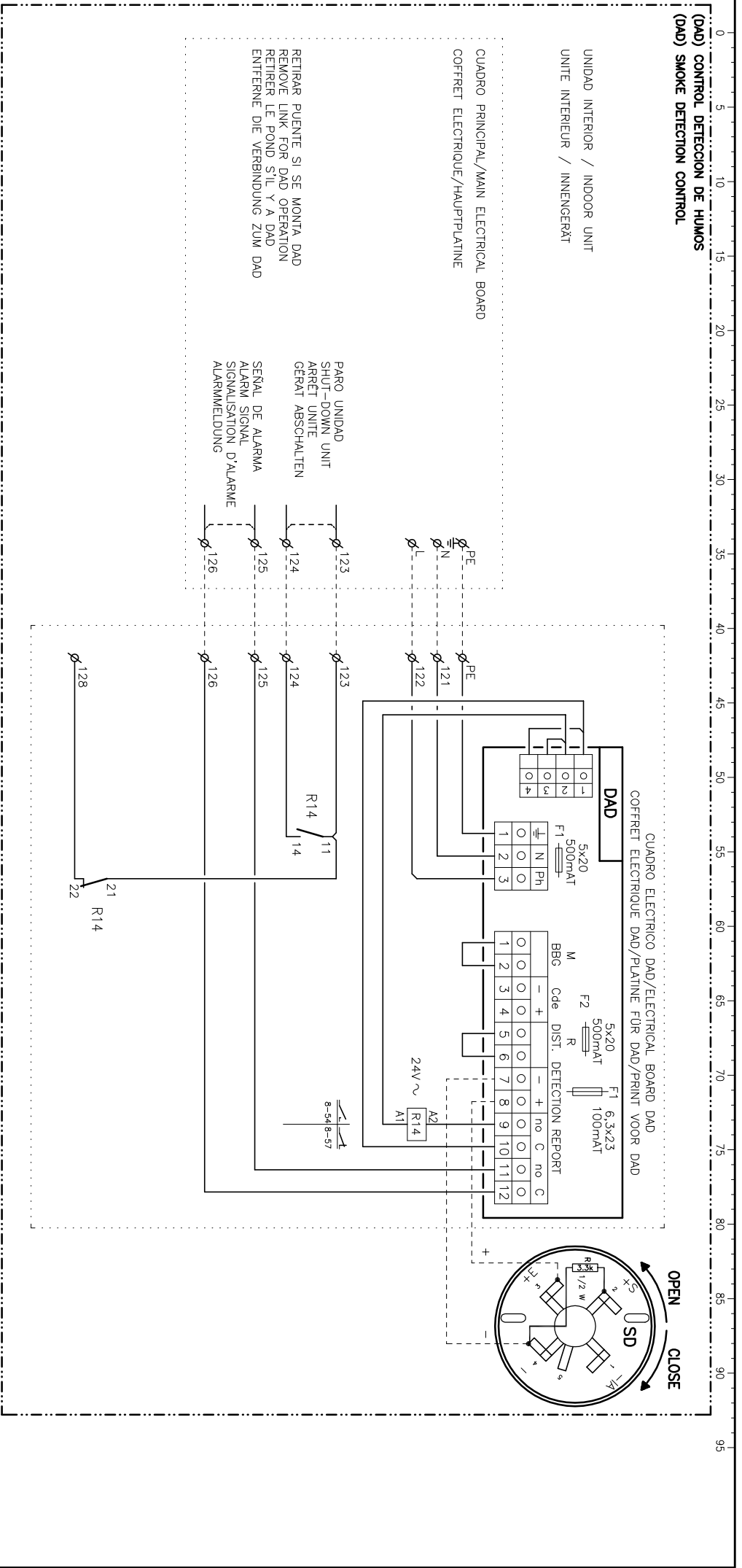

Elemento Opcional
 Optional Element
 Element optionnel
 Optionales bauteil

A realizar por el instalador
 To wire by the installer
 A câbler par l'installateur
 Verdrahtung durch den installateur

8/9
 Lennox Refrac S.A.

ESQUEMA ELECTRICO
 ELECTRIC DIAGRAM

ANHM 52D
C50

4Z-33-415-657 48H
 3N ~ 400V 50Hz + PE

