

INDICE	
REGLETERO CONEXIONES ELECTRICAS TERMINAL STRIP BORNIER DE CONNEXION ELECTRIQUE KLEMMLEISTE AANSLUITSTRIP	HOJA 1/8
CIRCUITO POTENCIA POWER CIRCUIT CIRCUIT DE PUISSANCE STROMKREIS HOOFDSTROOMCIRCUIT	HOJA 2/8
CIRCUITO MANIOBRA CONTROL CIRCUIT CIRCUIT DE CONTROL STEUERKREIS REGELCIRCUIT	HOJA 3/8
CIRCUITO SEÑALIZACION SIGNAL CIRCUIT CIRCUIT DE SIGNALISATION ALAMKREIS ALARMCIRCUIT	HOJA 4/8
CONEXION OPCIONALES OPTIONS CONNEXIONS OPCIONNELS OPTIONEN / ZUBEHÖR OPTIES	HOJA 5-6-7/8
LEYENDA REFERENCIAS REFERENCES LEGEND REFERENCE DE LEGENDE LEGENDE VERKLARING LEGENDA	HOJA 8/8



ESQUEMA ELECTRICO
WIRING DIAGRAM
SCHEMA ELECTRIQUE
SCHALTPLAN
ELECTRISCH SCHEMA

Elemento Opcional
Optional Element
Elément optionnel
Optionales bauteil
Optioneel element

A realizar por el instalador
To wire by the installer
A câbler par l'installateur
Verdrahtung durch den installateur
Installateurzijdig te bedraden

⚠ LA MANGUERA APANTALLADA DEBE CONECTARSE A TIERRA
 THE CABLE SCREEN MUST BE CONNECTED TO GROUND
 LA TRESSE DE BLINDAGE DOIT SE CONNECTER A LA TERRE
 DIE KABELABSCHIRMUNG MUSS GEERDET WERDEN
 DE AFSCHERMING MOET AAN AARDE VERBONDEN WORDEN

1 RETIRAR PUENTE SI SE MONTA ON/OFF REMOTO
 REMOVE LINK FOR REMOTE ON/OFF OPERATION
 RETIRER LE POND S'IL Y A MARCHE/ARRET A DISTANCE
 ENTFERNE DIE VERBINDUNG ZUM EIN/AUS FERNSCHALTER
 VERWIJDER LIK BIJ REMOTE ON/OFF

2 ESTAS BORNAS SOLAMENTE SE INCLUYEN CON SU OPCIONAL
 THESE TERMINALS ARE ONLY INCLUDED WITH ITS OPTIONAL
 CES CONTACTS SONT INSTALLES SEULEMENT SI ON DEMANDE LEUR OPTIONEL
 DIESE ANSCHLUSSKLEMMEN SIND NUR MIT ZUBEHÖR VERFÜGBAR IHREM
 DEZE AANSLUITKLEMMEN ZIJN ALLEEN VOORZIEN BIJ TOEPASSING VAN HUN OPTIONELE

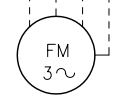
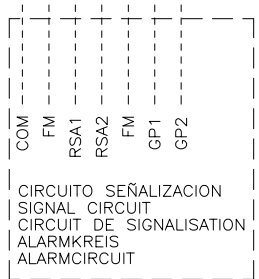
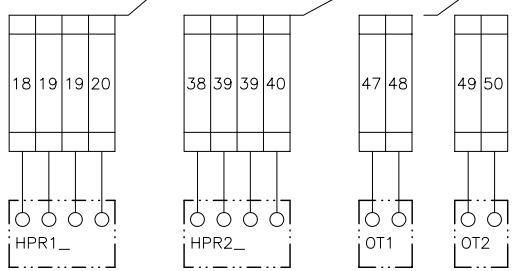
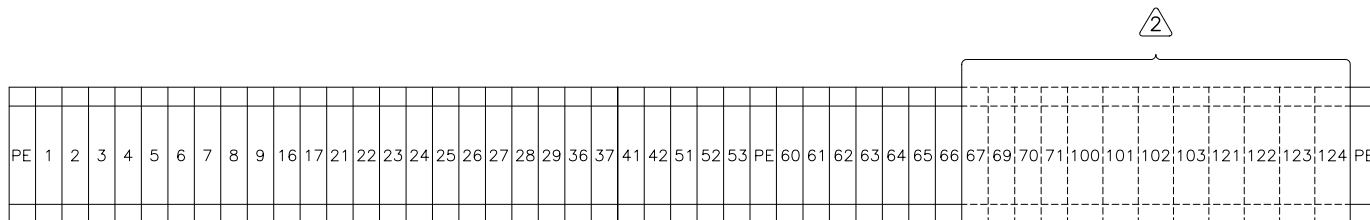

VENTILADOR U. INTERIOR
 INDOOR UNIT FAN
 VENTILATEUR D'UNITE INTERIEUR
 LÜFTER INNENGERÄT
 BINNENUNIT VENTILATOR

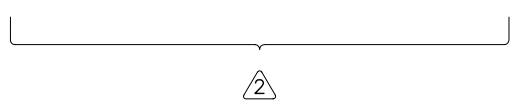

Elemento Opcional
 Optional Element
 A Realizar por el Instalador
 To Wire by the Installer

VER MANUAL INSTALACION
 SEE INSTALLATION MANUAL (IOM)
 VOIR LE MANUEL D'INSTALLATION
 SIEHE INSTALLATIONSHANDBUCH (IOM)
 ZIE INSTALLATION MANUAL (IOM)

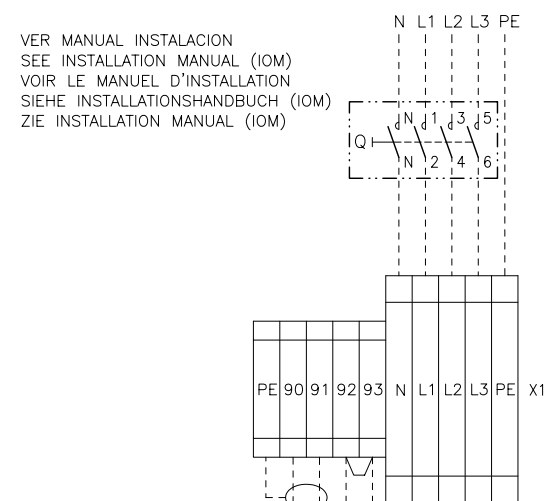

⚠ MANGUERA APANTALLADA
 SCREENED CABLE
 CABLE BLINDE
 ABGESCHIRMTES KABEL
 AFGESCHERMEDE KABEL

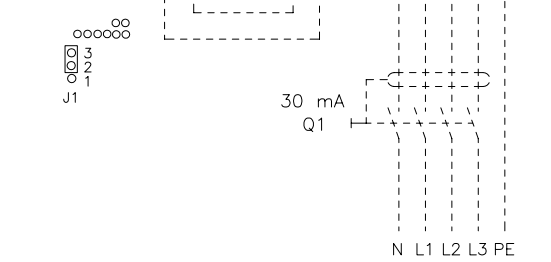
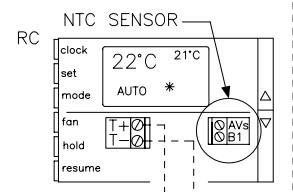

ALIMENTACION
 POWER SUPPLY
 ALIMENTATION ELECTRIQUE
 STROMZULEITUNG
 AANSLUITSPANNING
 3N~400V 50Hz+PE

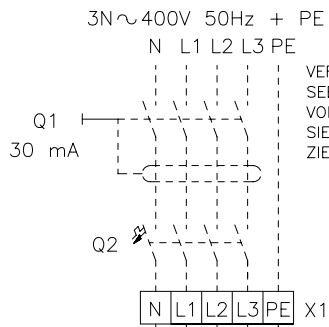

VER MANUAL INSTALACION
SEE INSTALLATION MANUAL (IOM)
VOIR LE MANUEL D'INSTALLATION
SIEHE INSTALLATIONSHANDBUCH (IOM)
ZIE INSTALLATION MANUAL (IOM)

FUSIBLES FUSES FUSIBLES SICHERUNGEN ZEKERINGEN		ANHK 100D
400V 3~50Hz	F1(CM1)	3x40A
	F3(CM2)	3x40A
	F5(CFM1)	3x10A
	F6(CFM2)	3x10A
	F7(FM)	3x20A

INTENSIDAD CURRENT INTESITÉ STROM STROOM		ANHK 100D	
		Im(MCC)	Ia(LRA)
400V 3~50Hz	CM1	29.8A	189A
	CM2	29.8A	189A
	CFM1	2.4A	8.4A
	CFM2	2.4A	8.4A
	FM	12A	72A

FUSIBLES BATERÍA ELEC. FUSES ELEC. HEATER FUSIBLES RESISTENCE ÉLEC. SICHERUNGEN E.-HEIZUNG ZEKRING ELECTRISCHE VERHITTER		ANHK 100D	
		30kW 1ST	40kW 1ST
400V 3~50Hz	F9(EH)	3x50A	3x63A

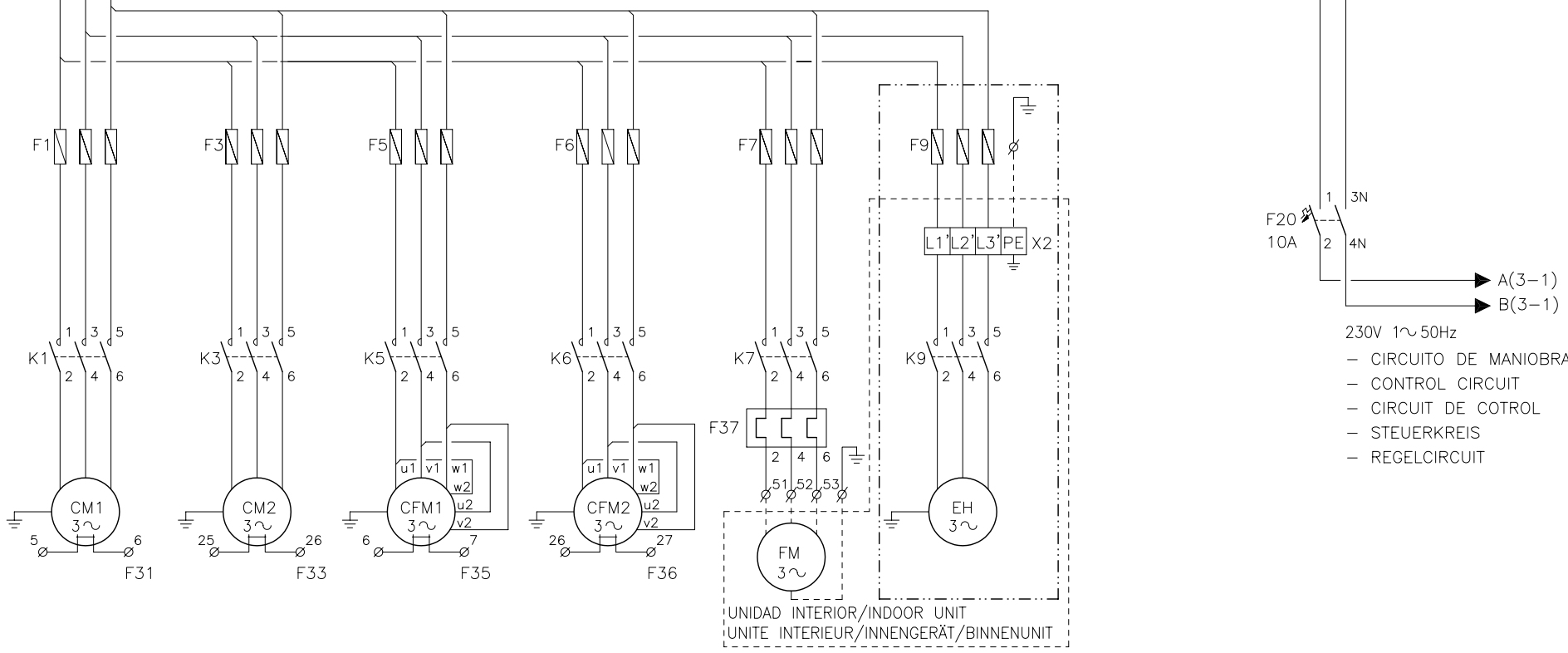
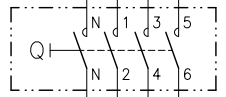

230V 1~50Hz
- CIRCUITO DE MANIOBRA
- CONTROL CIRCUIT
- CIRCUIT DE COTROL
- STEUERKREIS
- REGELCIRCUIT

Elemento Opcional
Optional Element
A Realizar por el Instalador
To Wire by the Installer

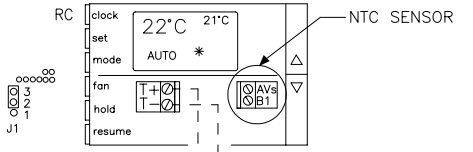
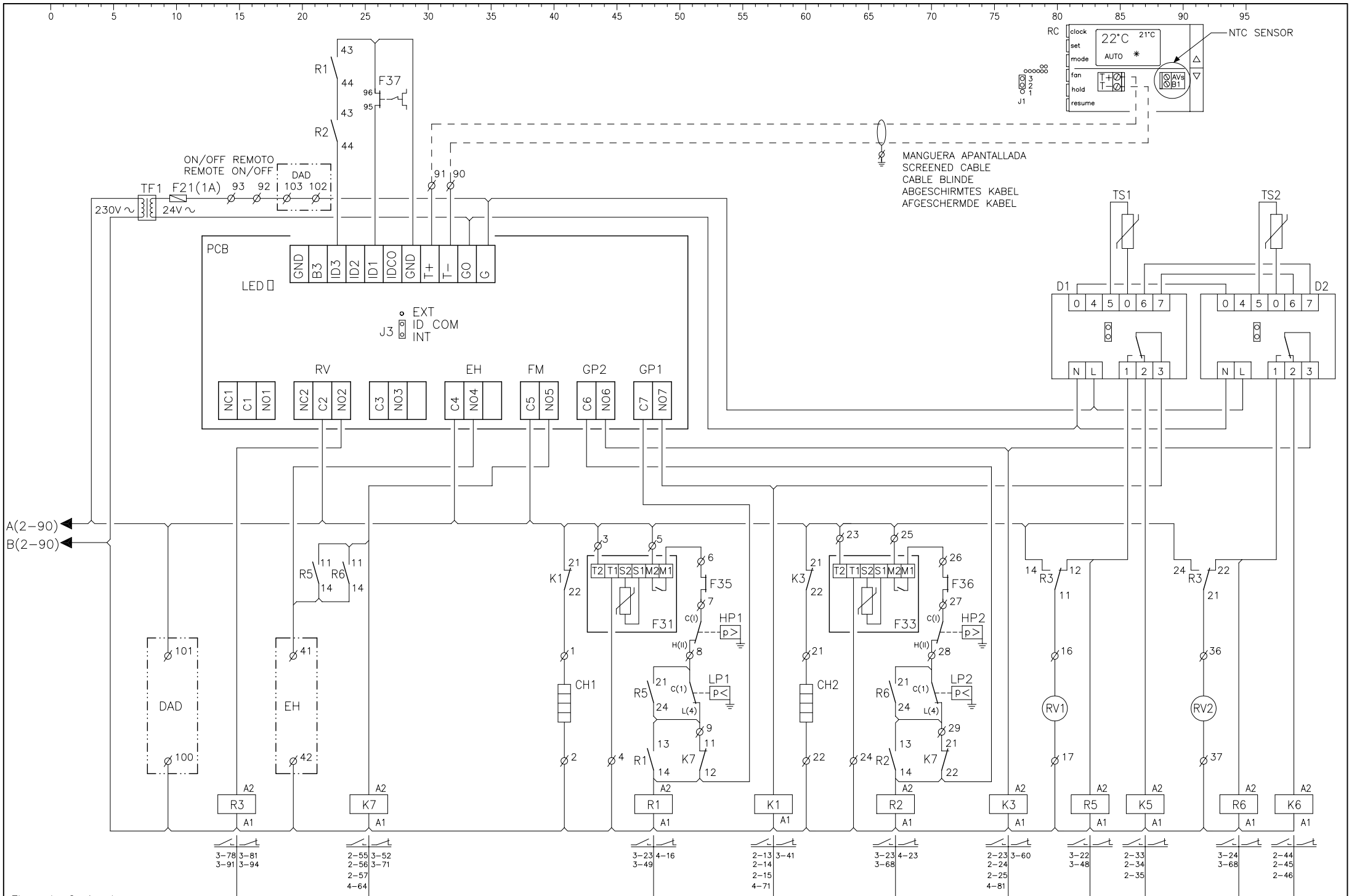

MANGUERA APANTALLADA
 SCREENED CABLE
 CABLE BLINDE
 ABGESCHIRMTES KABEL
 AFGESCHERMEDE KABEL

Elemento Opcional
 Optional Element
 A Realizar por el Instalador
 To Wire by the Installer

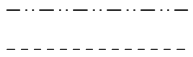

3/8

Lennox Refac S.A.

ESQUEMA ELECTRICO
 ELECTRIC DIAGRAM

ANHK (LEHK+KNHK)
 100D

4Z-33-443-409 27F
 3N~400V 50Hz + PE

CIRCUITO SEÑALIZACION
 SIGNAL CIRCUIT
 CIRCUIT DE SIGNALISATION
 ALAMKREIS
 ALARMCIRCUIT

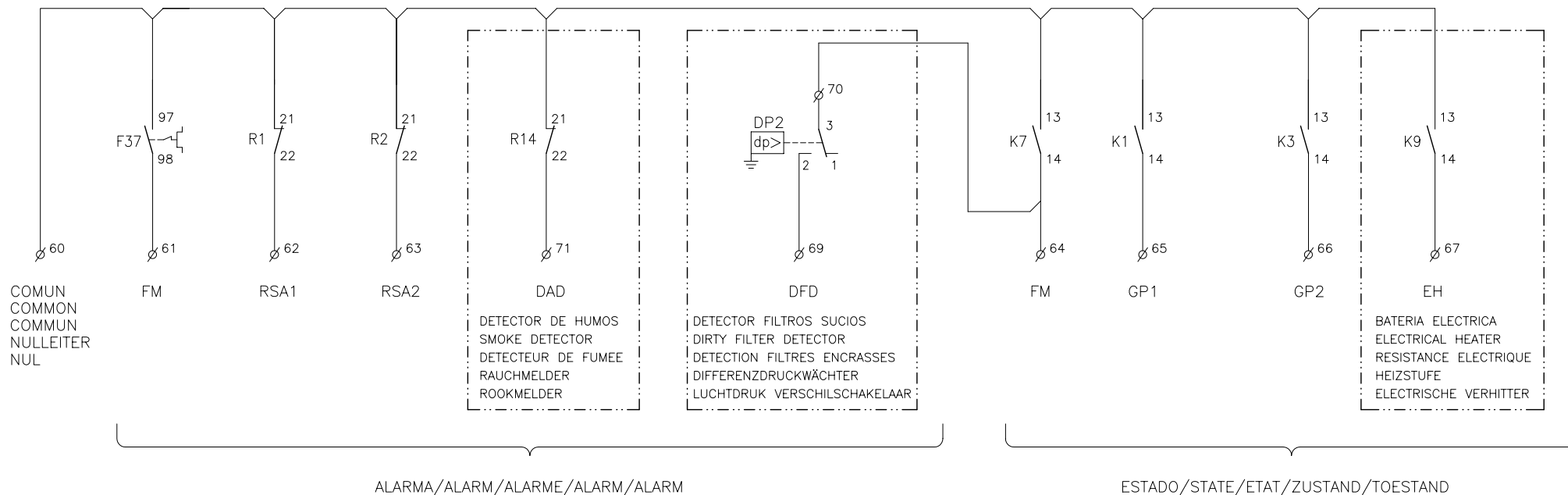

Elemento Opcional
 Optional Element
 A Realizar por el Instalador
 To Wire by the Installer

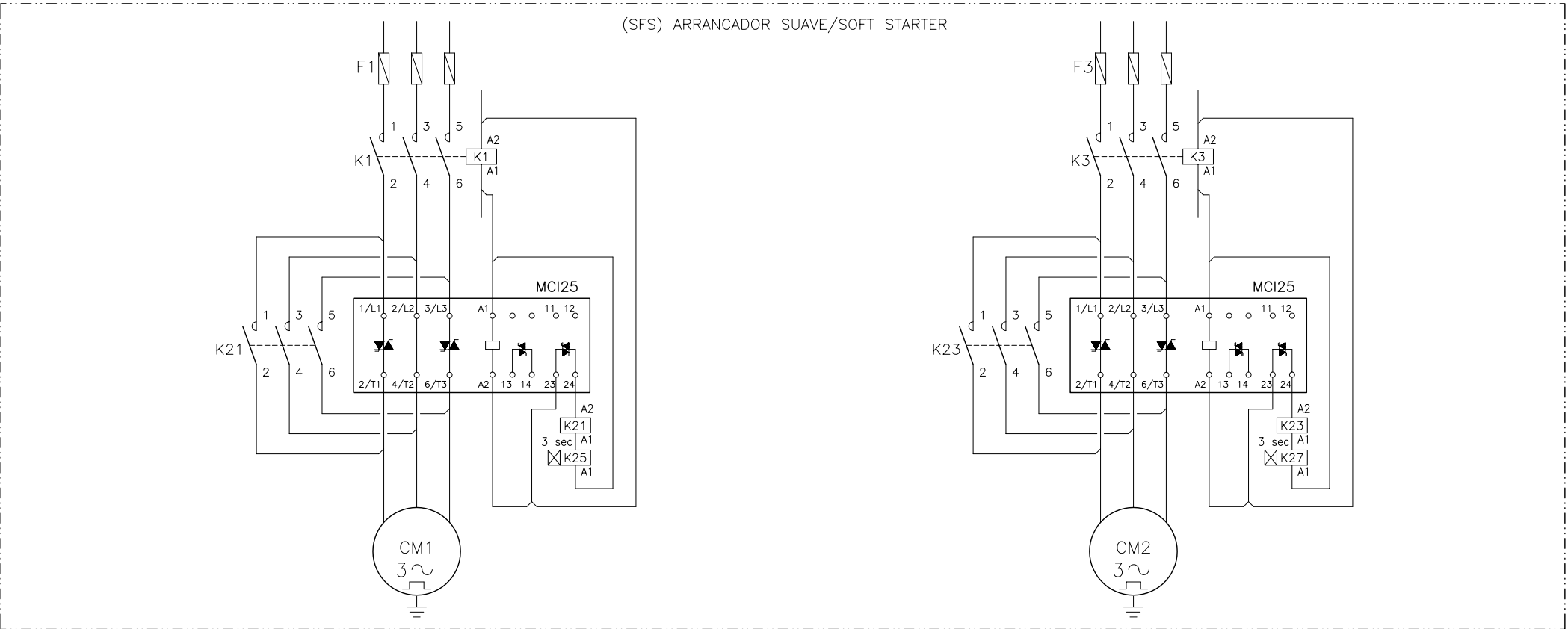
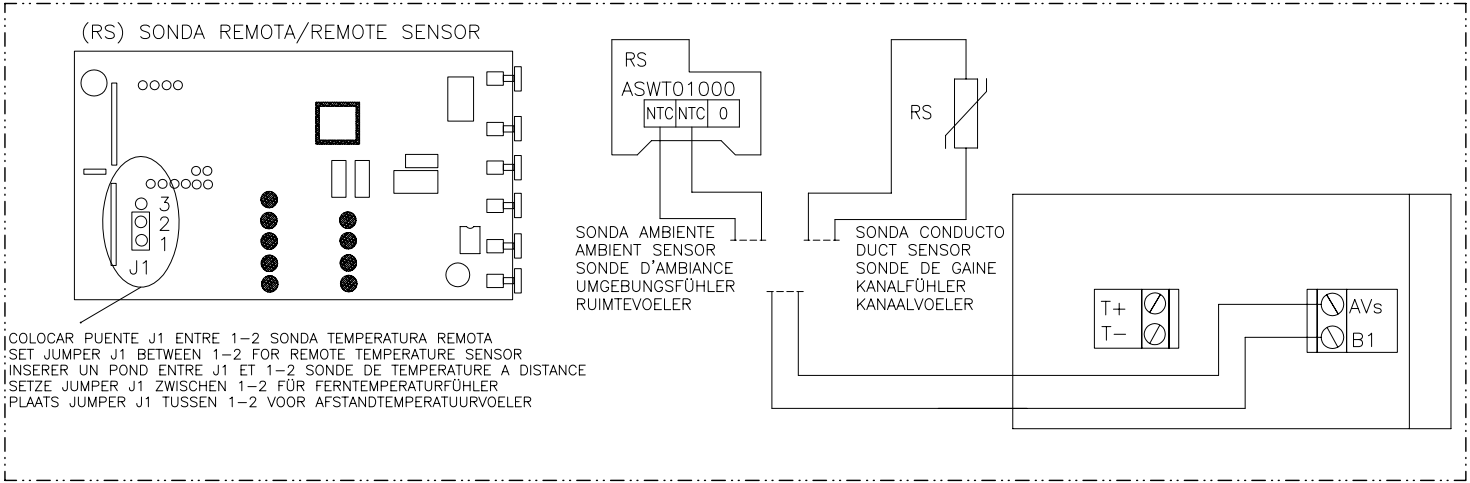
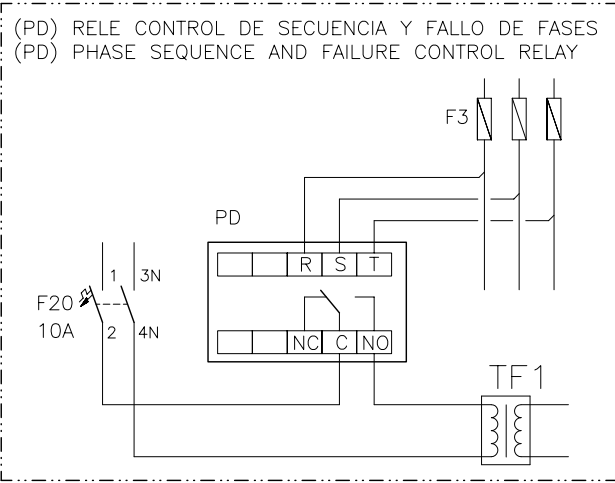

Elemento Opcional
Optional Element
A Realizar por el Instalador
To Wire by the Installer

(HPR) CONTROL CONDENSACION TODO/NADA
(HPR) WINTER CONTROL ON/OFF

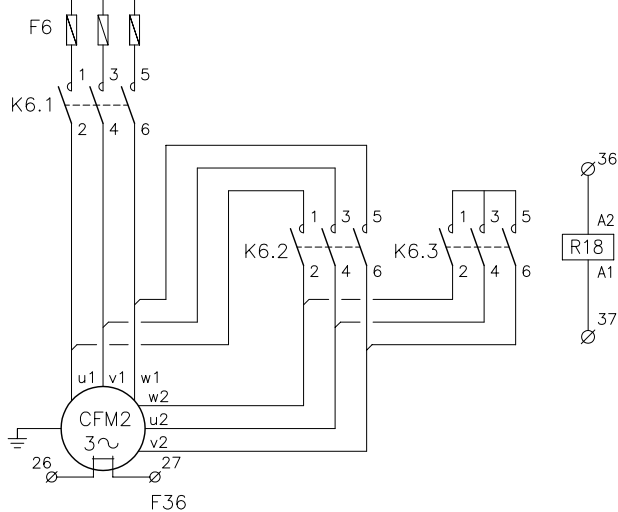
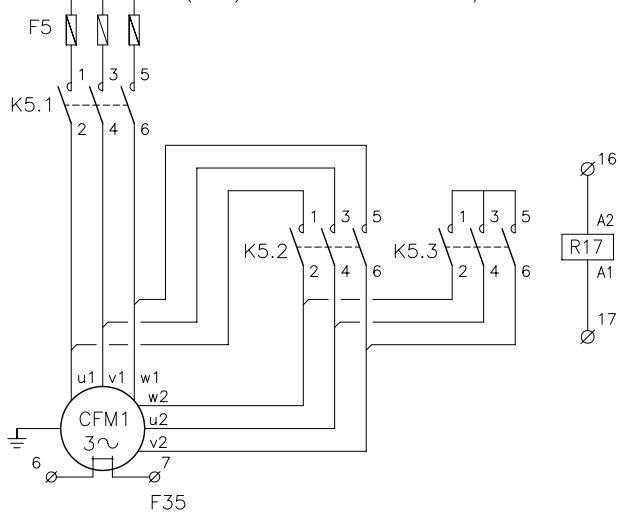

(FSC) CONTROL DE CONDENSACION/FAN SPEED CONTROL

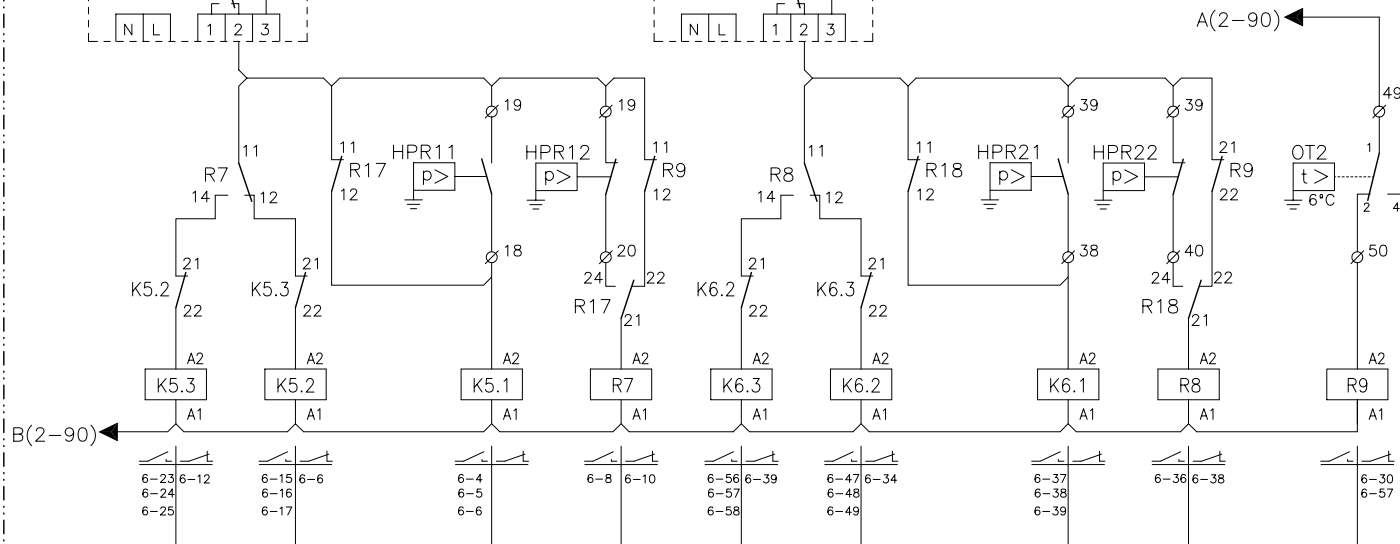
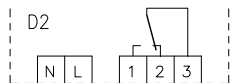
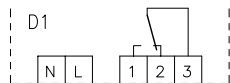
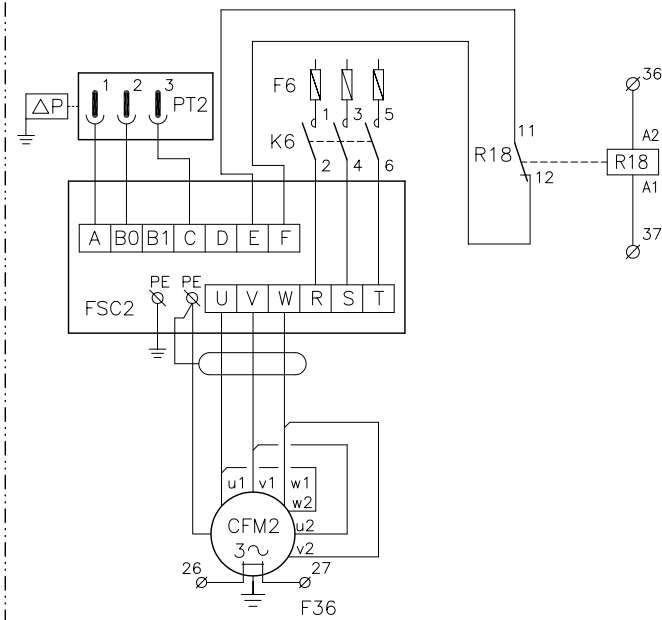
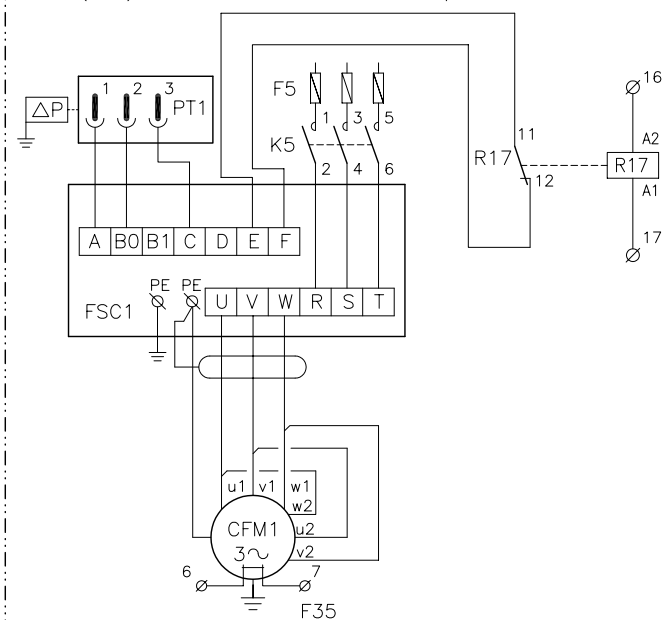

TARADO DE HPR(11-21): CORTE 14BAR REARME 17BAR. TARADO DE HPR(12-22): CORTE 26BAR REARME 24BAR
 HPR(11-21) SETPOINT: OFF 14BAR RESET 17BAR. HPR(12-22) SETPOINT: OFF 26BAR RESET 24BAR
 REGLAGE HPR(11-21): COUPURE 14BAR REARMEMENT 17BAR. REGLAGE HPR(12-22): COUPURE 26BAR REARMEMENT 24BAR
 HD-PRESSOSTAT(11-21): AUS BEI 14BAR RESET BEI 17BAR. HD-PRESSOSTAT(12-22): AUS BEI 26BAR RESET BEI 24BAR
 HD SETPOINT(11-21): OFF 14BAR RESET 17BAR. HD SETPOINT(12-22): OFF 26BAR RESET 24BAR

Elemento Opcional
 Optional Element
 A Realizar por el Instalador
 To Wire by the Installer

(DAD) CONTROL DETECCION DE HUMOS/SMOKE DETECTION CONTROL

CUADRO ELECTRICO DAD/ELECTRICAL BOARD DAD
COFFRET ELECTRIQUE DAD/PLATINE FÜR DAD/PRINT VOOR DAD

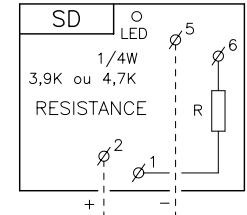
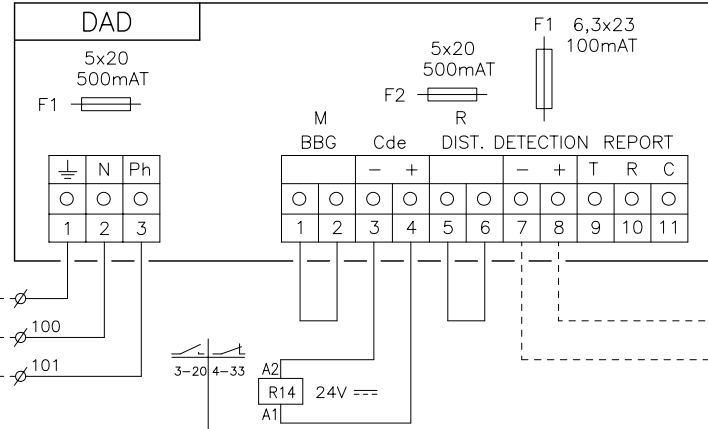

KIT LARGA DISTANCIA
KIT LONG DISTANCE

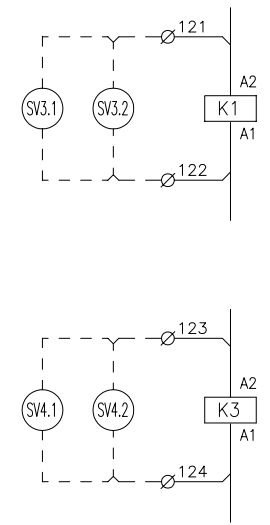

CUADRO PRINCIPAL/MAIN ELECTRICAL BOARD
COFFRET ELECTRIQUE/HAUPTPLATINE/HOOFDSTROOMPANEEL

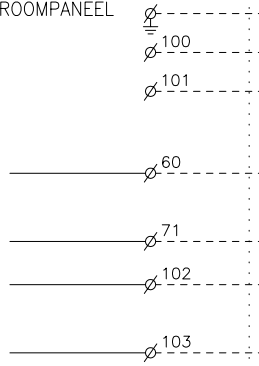

RETIRAR PUENTE SI SE MONTA DAD
REMOVE LINK FOR DAD OPERATION
RETIRER LE POND S'IL Y A DAD
ENTFERNE DIE VERBINDUNG ZUM DAD
VERWIJDER LIK BIJ DAD

SEÑAL DE ALARMA
ALARM SIGNAL
SIGNALISATION D'ALARME
ALARMMELDUNG
ALARM SIGNAL

PARO UNIDAD
SHUT-DOWN UNIT
ARRÊT UNITE
GÉRAT ABSCHALTEN
UNIT AFSCHAKELLEN

(BY) KIT BY PASS DE GAS CALIENTE
(BY) KIT HOT GAS BY PASS

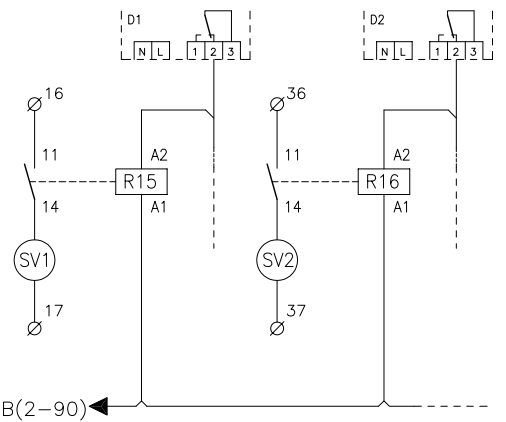

(DFD) DETECTOR FILTRO SUCIO
(DFD) DIRTY FILTER DETECTOR

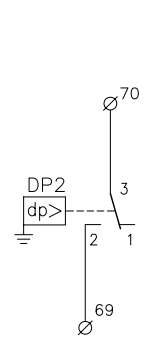

(EH) BATERIA ELECTRICA / ELECTRICAL HEATER

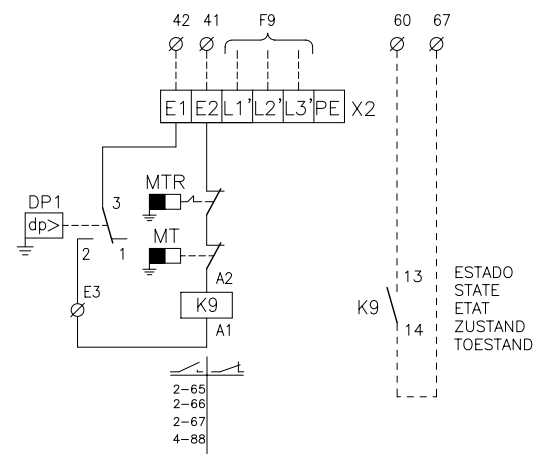

ESTADO
STATE
ETAT
ZUSTAND
TOESTAND

(HW) TERMOSTATO SEGURIDAD BAT. AGUA CALIENTE
(HW) SECURITY THERMOSTAT HEATER HOT WATER

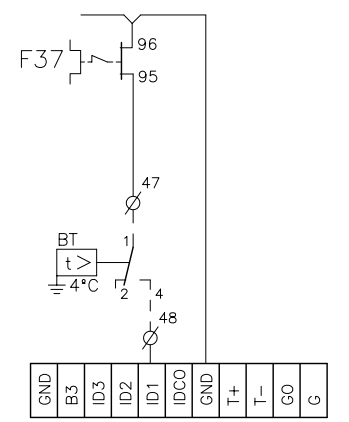

Elemento Opcional
Optional Element
A Realizar por el Instalador
To Wire by the Installer

	LEYENDA	LEGEND	REFERENCE	LEGENDE	LEGENDA
BT	Termostato Antihielo	Antifreeze Heater	Thermostat Antigél	Frostschutzthermostat	Vorstbescherming Thermostat
BY	Kit by pass de gas caliente	Kit hot gas by pass	By-pass de gaz chaud	Heissgasbypass	Hot gas by-pass
Cd	Condensador	Condenser	Condenseur	Kondensator	Condensor
CH	Resistencia de carter	Crankcase heater	Résistance de carter	Kurbelwannenheizung	Carterverwarming
CFM	Motor ventilador exterior	Compressor fan motor	Moteur ventilateur extérieur	Kondensatorlüftermotor	Condensor ventilador motor
CM	Motor compresor	Compressor motor	Compresseur	Kompressor	Compressor motor
D1-2	Control desescarche	Defrost control	Contrôleur de dégivrage	Abtauregler	Ontdooi regeling
DAD	Control detección de humos	Smoke detection control	Détecteur fumées	Rauchmelder	Rookdetector
DFD	Detector filtros sucios	Dirty filter detector	Détecteur filtres encrassés	Differenzdruckwächter	Luchtdruk verschilschakelaar
DP	Presostato diferencial aire	Air pressure differential switch	Pressostat différentiel d'air	differentialluftdruckschalter	Luft druk difereciaal schalter
EH	Batería eléctrica	Electrical heater	Résistance électrique	Heizstufe	Electrische verhitter
FM	Motor ventilador interior	Indoor fan motor	Moteur ventilateur intérieur	Innenventilatormotor	Verdamper ventilatormotor
FSC	Control de condensación	Fan speed control	Variateur de vitesse du ventilateur	Kondensationsdruckregelung	Ventilator snelheidsregelaar
F1-17	Fusibles	Fuses	Fusibles	Sicherungen	Zekeringen
F20	Magnetotérmico	Circuitbreaker	Disjacteur	Motorschutzschalter	Thermisch relais
F21	Fusible del TF1	TF1 fuse	Fusible TF1	TF1 schütz	TF1 zekering
F31-34	Módulo protección compresor	Compressor protector module	Module protection du compresseur	Therm. compressorrelais	Compressor beveiligings module
F35-47	Protección térmica	Thermal protection	Protection thermique	Therm. rrelais	Thermische beveiliging
GP	Grupo	Group	Grupe	Gruppe	Grupo
HP1-2	Presostato de alta	High pressure pressostat	Pressostat HP	Hochdruckpressostat	Hoge druk pressostaat
HPR1-2	Control condensación TODO/NADA	Winter control ON/OFF	C. pression condensation ON/OFF	K. druckregelung ON/OFF	Winter regeling AAN/UIIT
Ia(LRA)	Intensidad de arranque	Starting current	Intensité de démarrage	Anlaufstrom	Opstart stroom
Im(MCC)	Intensidad máxima	Maximum current	Intensité maximal	Maximale stromstärke	Maximaal stroom
J1,3	Puente	Jumper	Pont	Jumper	Jumper
K	Contacto	Contacto	Contacteur	Schütz	Relais
LP1-2	Presostato baja	Low pressure pressostat	Pressostat BP	Niederdruckpressostat	Lagedruk beveiling
MT	Termostato seguridad (70°C automático)	Safety thermostat (open 70°C autom. reset)	T. securité (70°C automatique)	Sicherheitsther. (70°C automatisch)	T. beveiliging (70°C autoreset)
MTR	Termostato seguridad (105°C manual)	Safety thermostat (open 105°C manu. reset)	T. securité (105°C manuel)	Sicherheitsther. (150°C manuell)	T. beveiliging (105°C handreset)
OT	Temperatura Exterior	Outdoor Temperature	Temperature Extérieure	Leistung Temperatur	Buiten Temperatuur
PCB	Placa control	Printed circuit board	Carte électronique	Steuerplatine	Printboard
PD	Relé control de secuencia-fallo de fases	Phase sequence and failure control relay	Détecteur de phases	Phasenfolgenüberwachung+Störemel	Fasevolgorde-foutcontrole relais
Q	Interruptor general	Main switch	Interrupteur général	Hauptschalter	Hoofdschakelaar
Q1	Interruptor diferencial	Ground safety switch	Interrupteur différentiel	Schalter	Aardlekschakelaar
Q2	Interruptor magnetotérmico	Circuit breaker	Interrupteur magneto thermique	Motorschutzschalter	Magneetschakelaar
R1-20	Relé auxiliar	Auxiliary relay	Relais auxiliaire	Hilfsrelais	Aux. relais
RC	Control remoto	Remote control	Commande à distance	Fernbedienung	Afstandsbediening
RS	Sonda remota ambiente	Ambient remote sensor	Sonde temp. à distance	Umgebungsfernfühler	Ruimtevoeler
RSA1-2	Relé señal alarma	Alarm signal relay	Relais défaut à distance	Störmelderelais	Storingrelais
RV1-2	Válvula inversora (frío ON)	Reversing valve (cooling ON)	Vanne 4 vois (activé en mode froid)	Umschaltrelais (kühlen ON)	Omkeerklep (koel=bekrachtigd)
SD	Sensor detector de humos	Smoke detection sensor	Sonde de détection de fumées	Rauchmelder	Rookmelder
SFS	Arrancador suave	Soft starter	Démarreur progressif	Softstarter/Sanftanlauf	Soft starter
SV	Válvula solenoide	Solenoid valve	Vanne solénoïde	Magnetventil	Magneet ventiel
TF1	Transformador	Transformer	Transformateur	Transformator	Transformator
TS1-2	Sonda temp. batería unidad exterior	Outdoor unit coil temperature sensor	Sonde temp. batterie extérieur	Temperaturfühler condensator	Buitenunit bloktemp. opnemer
	CODIGO DE COLORES	COLOUR CODE	CODE COULEUR	FARBKENNUNG	KLEURCODE
bk	negro	black	noir	schwarz	zwart
br	marrón	brown	brun	braun	bruin
rd	rojo	red	rouge	rot	rood
or	naranja	orange	orange	orange	oranje
yl	amarillo	yellow	jaune	gelb	geel
gn	verde	green	vert	grün	groen
bl	azul	blue	bleu	blau	blauw
vi	violeta	violet	violet	violet	violet
gr	gris	gray	gris	grau	grijs
wh	blanco	white	blanc	weiss	wit