

**Installation,
operating
and maintenance**

AIRCOOLAIR

ASC/ASH

ASC/ASH + CIC/CIH

Large ducted split
19 → 134 kW

ASC/ASH

Air cooled condensing unit
20 → 230 kW



TABLE OF CONTENTS

AIRCOOLAIR OUTDOOR UNITS INSTALLATION OPERATION MAINTENANCE MANUAL

POINTS TO BEAR IN MIND	2
DATA PAGE FOR COMMISSIONING OF THE UNIT	3
1 - GENERAL CHARACTERISTICS	
1.1 Physical data	4
1.2 Electrical data	5
1.3 Fan performance	6
1.4 Operating limits	6
1.5 Piping drawings	7
1.6 Unit dimensions	11
2 - INSTALLATION	
2.1 Preliminary preparations	12
2.2 Unit acceptance	12
2.3 Unit location	13
2.4 Installation clearances	13
2.5 Inside location	14
2.6 Refrigerant connections	15
2.7 Electrical connections	19
2.8 Dry contact board control	21
2.9 Options installation	22
3 - COMMISSIONING AND OPERATION	
3.1 Preliminary checks before first installation	23
3.2 Preliminary checks at first installation	24
4 - MAINTENANCE	
4.1 Preventive maintenance	25
4.2 Corrective maintenance	25
4.3 Fault diagnosis	26

WARNING: Read this manual before carrying out installation, repair or maintenance work.

All the technical and technological information contained in this manual, including any drawings and technical descriptions provided by us, remain the property of Lennox and must not be utilised (except in the operation of this product), reproduced, issued to or made available to third parties without the prior written agreement of Lennox.

POINTS TO BEAR IN MIND

DANGER AND WARNING SIGNS



Abrasive surfaces



Low temperatures



High temperatures



Risk of injury from moving objects



Electrical voltage



Risk of injury from rotating objects

ELECTRICAL CONNECTIONS



Make sure to switch off the power before installing, repairing or carrying out maintenance on the unit, in order to prevent serious electrical injury.

Keep local and national legislation in mind when installing the unit.

Standard Guidelines to Lennox equipment

All technical data contained in these operating instructions, including the diagrams and technical description remains the property of Lennox and may not be used (except for the purpose of familiarizing the user with the equipment), reproduced, photocopied, transferred or transmitted to third parties without prior written authorization from Lennox.

The data published in the operating instructions is based on the latest information available. We reserve the right to make modifications without notice.

We reserve the right to modify our products without notice without obligation to modify previously supplied goods.

These operating instructions contain useful and important information for the smooth operation and maintenance of your equipment.

The instructions also include guidelines on how to avoid accidents and serious damage before commissioning the equipment and during its operation and how to ensure smooth and fault-free operation. Read the operating instructions carefully before starting the equipment, familiarize yourself with the equipment and handling of the installation and carefully follow the instructions. It is very important to be properly trained in handling the equipment. These operating instructions must be kept in a safe place near the equipment.

Like most equipment, the unit requires regular maintenance. This section concerns maintenance and management personnel.

If you have any queries or would like to receive further information on any aspect relating to your equipment, do not hesitate to contact us.

The manufacturing of these units is made under the requirements of the ISO 9001 and ISO 14001.

DATA PAGE FOR UNIT COMMISSIONING

UNIT: _____ SERIAL NUMBER : _____

CONTROL PANEL IDENTIFICATION CODE : _____

INSTALLATION ADDRESS: _____

INSTALLER : _____ INSTALLER TEL : _____

INSTALLER ADDRESS : _____

COMMISSIONING DATE : _____

CHECKS : _____

SUPPLY VOLTAGE : _____ RATED VOLTAGE OF THE UNIT : _____

	YES	NO
Unit on shock absorbers		
Drainage with trap		
Main power supply connection		
Control panel connection		
Compressor oil level indicator		

DATA INPUT:

COOLING CYCLE

Air intake temperature to the outdoor coil: _____ 1 _____ °C
 _____ 2 _____ °C

Air output temperature to the outdoor coil: _____ 1 _____ °C
 _____ 2 _____ °C

High pressure: _____ Circuit 1 _____
 _____ Circuit 2 _____

Low pressure: _____ Circuit 1 _____
 _____ Circuit 2 _____

HEATING CYCLE

Air intake temperature to the outdoor coil: _____ 1 _____ °C
 _____ 2 _____ °C

Air output temperature to the outdoor coil: _____ 1 _____ °C
 _____ 2 _____ °C

High pressure: _____ Circuit 1 _____
 _____ Circuit 2 _____

Low pressure: _____ Circuit 1 _____
 _____ Circuit 2 _____

ELECTRIC POWER CONSUMPTION (Amps)

Compressor 1:..... — / — / — Compressor 1:..... — / — / —

Compressor 2 : — / — / — Compressor 2 : — / — / —

Compressor 3 : — / — / — Compressor 3 : — / — / —

Outdoor fan section 1 — / — / — Outdoor fan section 1 — / — / —

Outdoor fan section 2 — / — / — Outdoor fan section 2 — / — / —

Options installed : _____

Comments : _____

1. GENERAL CHARACTERISTICS

1.1.- PHYSICAL DATA

A	S	C	020	S	N	M	3	M
Unit AIRCOOLAIR		C: Cooling only H: Heat pump		S: One Circuit D: Two Circuits		Type of refrigerant M: R-410A		M: 400V/3/50
	S: Outdoor unit Split		Approximate cooling capacity in kW		---			Number of revision



ASC/ADC: Cooling only unit R-410A.
ASH/ADH: Heat pump unit R-410A.

MODELS	ASC/ASH	020S	025S	030S	035S	
Type of compressor	Scroll					
Number of compressors	1					
Net weight	Cooling only unit ASC/ADC	kg	255	443	452	520
	Heat pump unit ASH/ADH		258	452	463	537
	Optional Soft starter		3	6	6	6
	Optional FP1		N/A			
Air flow	m ³ /h	11000	9750+9750	11500+11500	11000+11000	
Refrigerant charge	NITROGEN (*)					

n/a: not available

MODELS	ASC/ASH	040S	045D	055D	070D	085D	
Type of compressor	Scroll						
Number of compressors	1						
Net weight	Cooling only unit ASC/ADC	kg	255	443	452	481	520
	Heat pump unit ASH/ADH		258	452	463	499	537
	Optional Soft starter		3	6	6	6	6
	Optional FP1		N/A				
Air flow	m ³ /h	11000	9750+9750	11500+11500	11300+11300	11000+11000	
Refrigerant charge	NITROGEN (*)						

n/a: not available

MODELS	ASC/ASH	100D	120D	140D	200D	230D	
Type of compressor	Scroll						
Number of compressors	2						
Net weight	Cooling only unit ASC/ADC	kg	632	797	906	1659	1679
	Heat pump unit ASH/ADH		748	828	932	1684	1704
	Optional Soft starter		9	9	9	n/a	n/a
	Optional FP1		40	40	40	80	80
Air flow	m ³ /h	22700+18100	22700+18100	22700+22700	28600+28600	36000+36000	
Refrigerant charge	NITROGEN (*)						

(*) The units are supplied with nitrogen gas; this must be removed and the unit charged with refrigerant R-410A, depending on unit model.

(See page 21 to calculate refrigerant charge for model ASC/ADC and ASH/ADH units to work with indoor units CIC/CIH).
R-410A factory refrigerant precharge kit is available as an option.

1. GENERAL CHARACTERISTICS

1.2.- ELECTRICAL DATA

ELECTRICAL CONSUMPTION FOR STANDARD UNITS

MODELS ASC/ASH		020S	025S	030S	035S	040S	045D	055D
Voltage	Ph/V/Hz	3N~400V 50Hz	3~400V 50Hz					
Maximum absorbed power (kW)								
Compressor		8,25	10,1	11,8	15,6	16,9	20,2	23,6
Fan		0,3	0,69	0,69	0,84	0,84	1,38	1,38
Total power		8,55	10,79	12,49	16,44	17,74	21,58	24,98
Maximum current (A)								
Compressor		15	21	22	25,6	31	42	44
Fan		1,6	3	3,4	3,4	3,4	6	6,8
Total current		16,6	24	25,4	29	34,4	48	50,8
Start up current (A)		87,5	97,4	104	138	17,2	121	129

MODELS ASC/ASH		070D	085D	100D	120D	140D	200D	230D
Voltage	Ph/V/Hz	3~400V 50Hz						
Maximum absorbed power (kW)								
Compressor		31,1	33,8	42,6	45,6	55,9	78,8	88,2
Fan		1,68	1,68	3,05	3,05	4	4,2	8
Total power		32,78	35,48	45,65	48,65	59,9	83	96,2
Maximum current (A)								
Compressor		51,2	62	77,6	84	102	142	159
Fan		6,8	6,8	6,4	6,4	8	9,6	16
Total current		58	68,8	84	90,4	110	151,6	175
Start up current (A)		167	206	221	228	292	302,9	358

ADDITIONAL ELECTRICAL CONSUMPTION FOR THE OPTIONS

FP1 OPTION ASC/ASH		100D FP1 (Low Speed/ High speed)	120D FP1 (Low Speed/ High speed)	140D FP1 (Low Speed/ High speed)	200D FP1 (Low Speed/ High speed)	230D FP1 (Low Speed/ High speed)
Voltage	Ph/V/Hz	3/400V/50Hz				
Maximum absorbed power	kW	2,00 / 6,20	2,00 / 6,20	1,00 / 5,2	5,8 / 14,2	2 / 10,4
Maximum current	A	3,2 / 9,8	3,2 / 9,8	1,6 / 8,2	9,6 / 22,8	3,2 / 16,4
Start up current	A	3,2 / 9,8	3,2 / 9,8	1,6 / 8,2	9,6 / 22,8	3,2 / 16,4

1. GENERAL CHARACTERISTICS

1.3.- FAN PERFORMANCES

1.3.1.- OUTDOOR UNIT WITH AVAILABLE HIGH PRESSURE FAN (OPTION)

Air flow data / FP1 option / Low speed.

MODELS				100D - 120D - 140D	200D	230D
Fan type				Axial "short case" - direct coupling 900 r.p.m. (Low speed) 3~400V		
Fan number				2	4	
Available static pressure (Pa)	50	Airflow rate	m ³ /h	19000 + 19000	28000 + 28000	
		Absorbed power	kW	5	10	
	75	Airflow rate	m ³ /h	18000 + 18000	24000 + 24000	
		Absorbed power	kW	5,1	10.2	
	100	Airflow rate	m ³ /h	17000 + 17000	22000 + 22000	N/A
		Absorbed power	kW	5,2	10,4	N/A
	125	Airflow rate	m ³ /h	15000 + 15000	20000 + 20000	N/A
		Absorbed power	kW	5,3	10,6	N/A

n/a: Not available

Air flow data. FP1 option. High speed.

MODELS				100D - 120D - 140D	200D - 230D
Fan type				Axial "short case"-direct coupling 1450 r.p.m. (High speed) 3~400V	
Fan number				2	4
Available static pressure Pa,	50	Airflow rate	m ³ /h	22000 + 22000	34000 + 34000
		Absorbed power	kW	9,2	18,4
	100	Airflow rate	m ³ /h	20000 + 20000	28000 + 28000
		Absorbed power	kW	9,3	18,6
	125	Airflow rate	m ³ /h	18000 + 18000	24000 + 24000
		Absorbed power	kW	9,4	18,8

1.4.- OPERATING LIMITS

COOLING ONLY UNITS		Maximum temperatures	Minimum temperatures
Cooling cycle operation	Indoor temperature	32°C DB 23°C WB	21°C DB 15°C WB
	Outdoor temperature	45°C (20S-25S-30S-45D-55D) ----- 47°C (35S-40S-70D-85D-100D-120D-140D)	+10°C STANDARD UNIT (*) / (**)
HEAT PUMP UNITS		Maximum temperatures	Minimum temperatures
Cooling cycle operation	Indoor temperature	32°C DB 23°C WB	21°C DB 15°C WB
	Outdoor temperature	20S-25S-30S-45D-55D) ----- 47°C (35S-40S-70D-85D-100D-120D-140D)	0°C
Heating cycle operation	Indoor temperature	27°C DB	15°C DB
	Outdoor temperature	Depending on model (See tables for heating capacities)	-10°C DB -11°C WB

(*) With low temperature 0°C kit (option)

DB: Dry bulb temperature.

(**) With option kit low temperature -15°C or kit -15°C and low noise level.

WB: Wet bulb temperature

1. GENERAL CHARACTERISTICS

1.5.- PIPING DRAWINGS

COOLING ONLY UNITS

INDOOR UNIT

CIC 020S/025S/030S/035S/040S

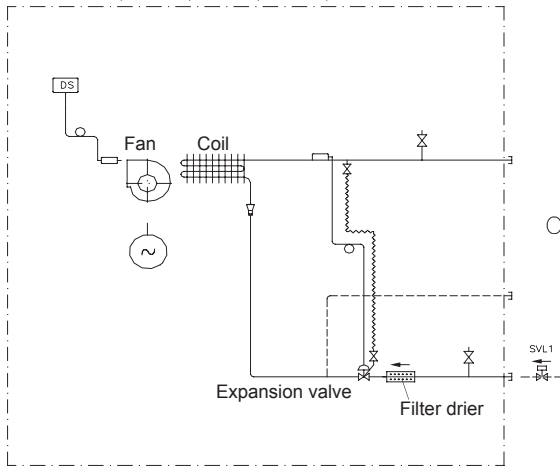

-----OPTION ELEMENT

OUTDOOR UNIT

ASC 020S/025S/030S/035S/040S

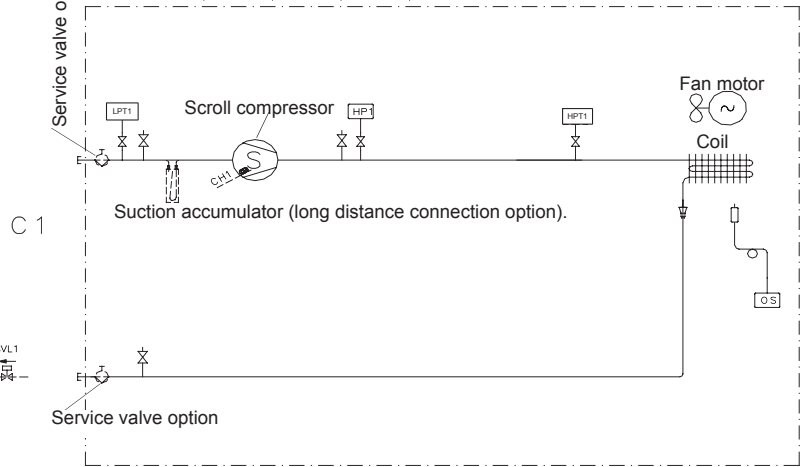

INDOOR UNIT

CIC 045D/055D/070D/085D

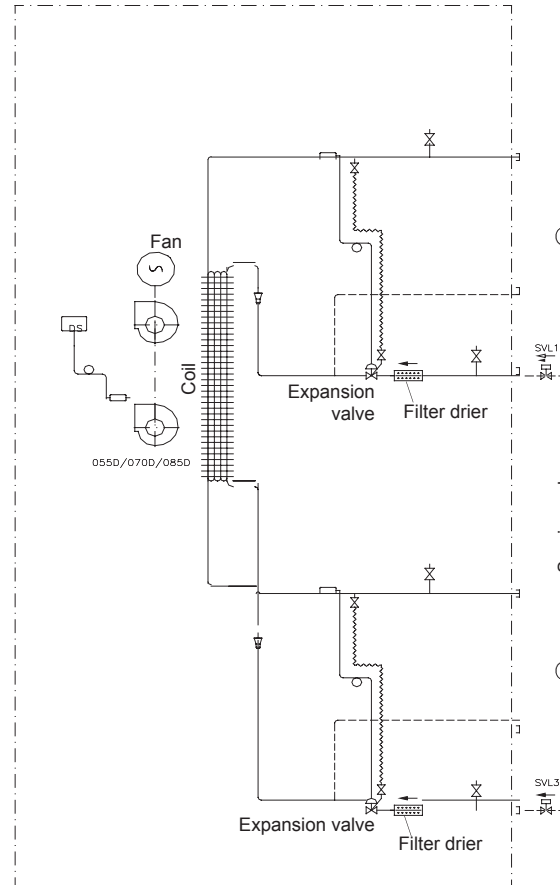

-----OPTION ELEMENT

OUTDOOR UNIT

ASC 045D/055D/070D/085D

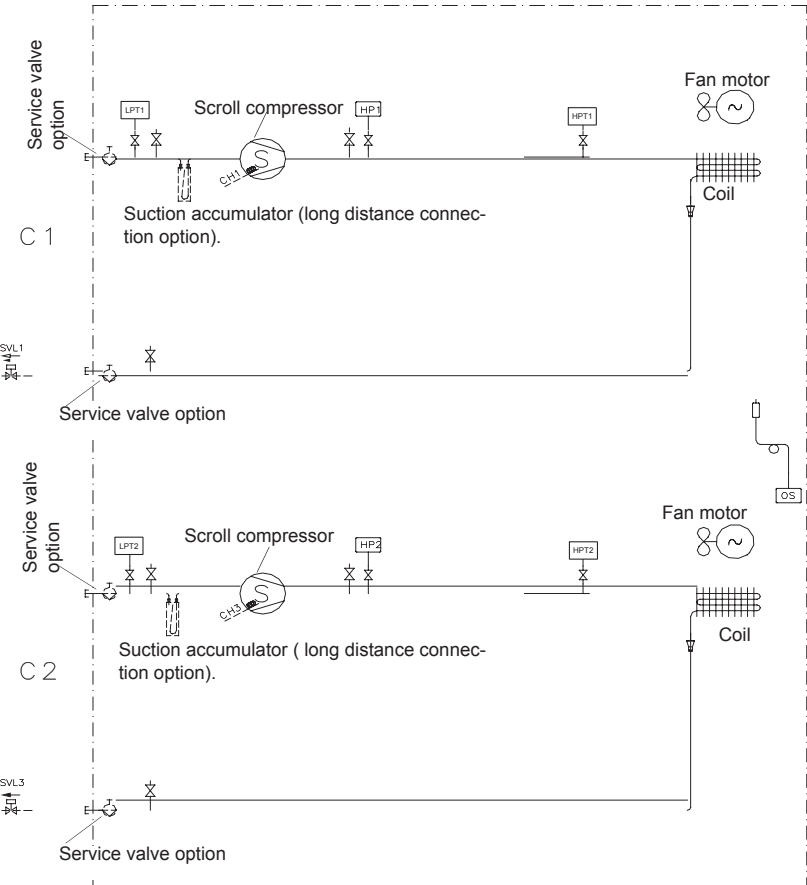

	Pressure gauge (5/16" to be fitted by the installer)	HP1	High pressure switch, circuit 1
DS	Discharge sensor	HP2	High pressure switch, circuit 2
SVL1	Liquid solenoid valve. (long distance option)	CH1	Crankcase heater (Low ambient option)
SVL3	To be connected by the installer to indoor units.	CH3	Crankcase heater (Low ambient option)
LPT1	Low pressure switch, circuit 1	HPT1	High pressure transducer, circuit 1
LPT2	Low pressure transducer, circuit 2	HPT2	High pressure transducer, circuit 2
		OS	Outdoor temperature sensor

1. GENERAL CHARACTERISTICS

1.5.- PIPING DRAWINGS COOLING ONLY UNITS

INDOOR UNIT

CIC 100D/120D/140D

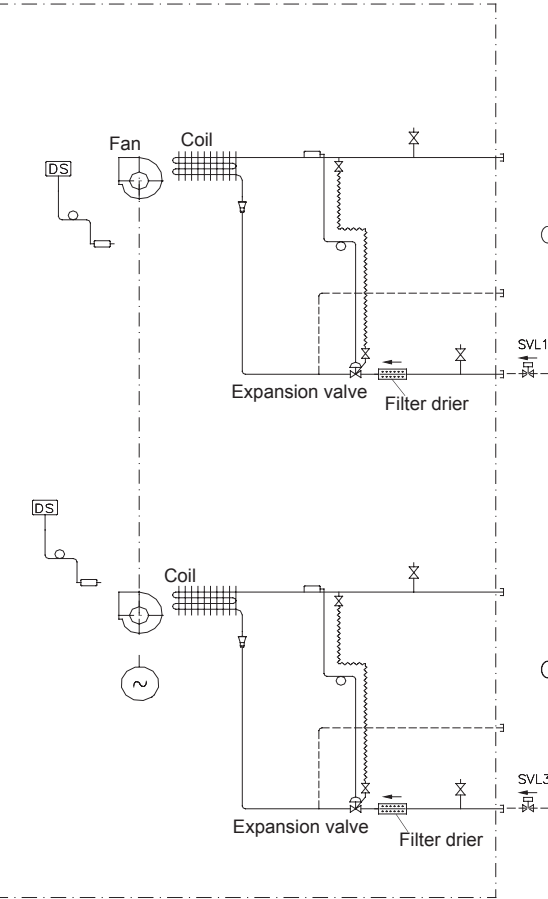

----- OPTION ELEMENT

OUTDOOR UNIT

ASC 100D/120D/140D

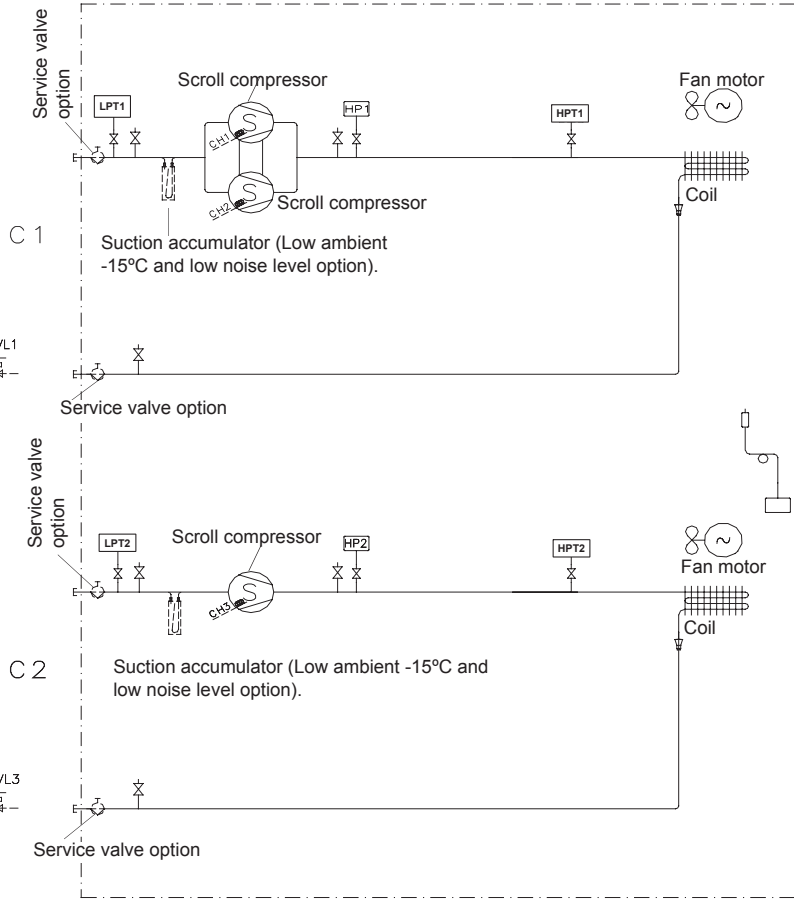

	Pressure gauge. (5/16" to be fitted by the installer)	HP1	High pressure switch, circuit 1.
DS	Discharge sensor	HP2	High pressure switch, circuit 2.
SVL1	Liquid solenoid valve. (long distance option)	CH...	Crankcase heater (Low ambient option)
SVL3	To be connected by the installer to indoor units.	HPT1	High pressure transducer, circuit 1
LPT1	Low pressure switch, circuit 1	HPT2	High pressure transducer, circuit 2
LPT2	Low pressure transducer, circuit 2	OS	Outdoor temperature sensor

1. GENERAL CHARACTERISTICS

1.5.- PIPING DRAWINGS COOLING ONLY UNITS

OUTDOOR UNIT

ASC 200-230D

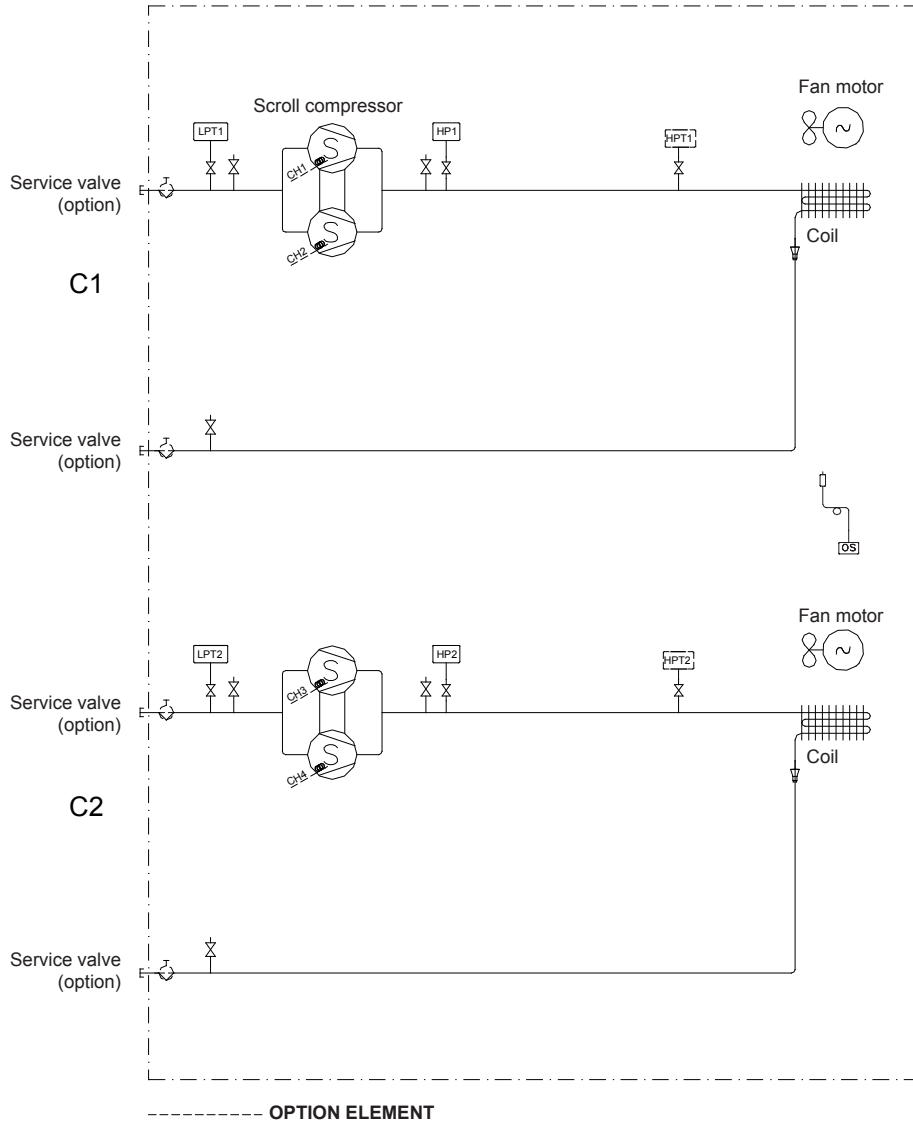

	Pressure gauge (5/16" to be fitted by the installer)	CH...	Crankcase heater (0°C Low ambient option)
LPT1	Low pressure switch Circuit 1	HPT1	High pressure transducer Circuit 1
LPT2	Low pressure switch Circuit 2	HPT2	High pressure transducer Circuit 2
HP1	High pressure switch Circuit 1	OS	Outdoor temperature sensor
HP2	High pressure switch Circuit 2		

1. GENERAL CHARACTERISTICS

1.5.- PIPING DRAWINGS HEAT PUMP UNITS

INDOOR UNIT

CIH 020S/025S/030S/035S/040S

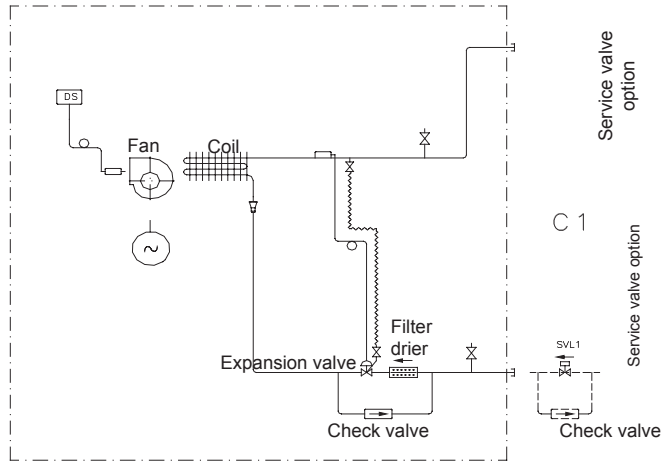

OUTDOOR UNIT

ASH 020S/025S/030S/035S/040S

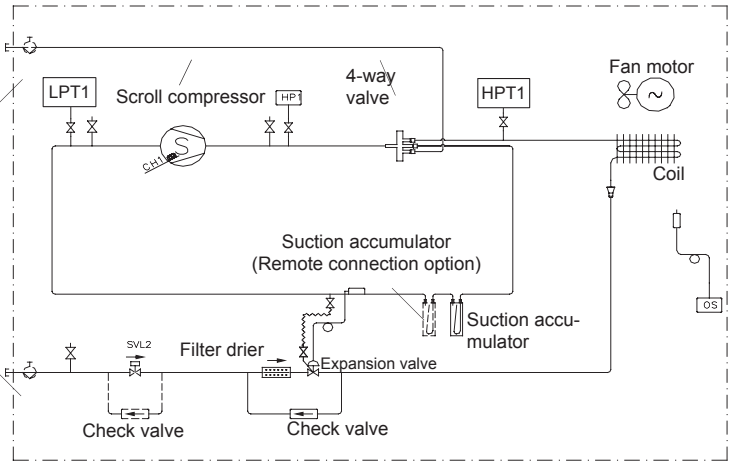

OPTION ELEMENT

INDOOR UNIT

CIH 045/055D/070D/085D

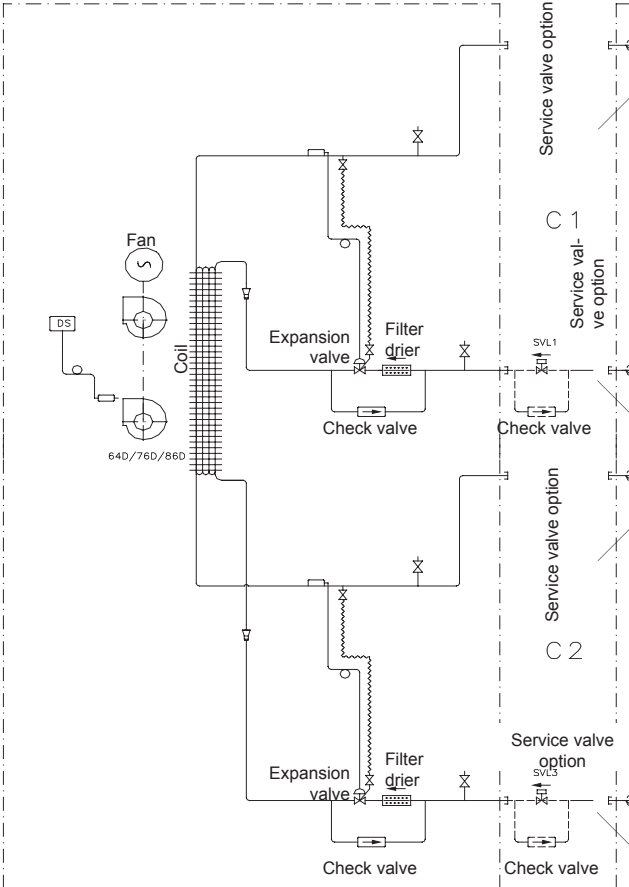

OUTDOOR UNIT

ASH 045/055D/070D/085D

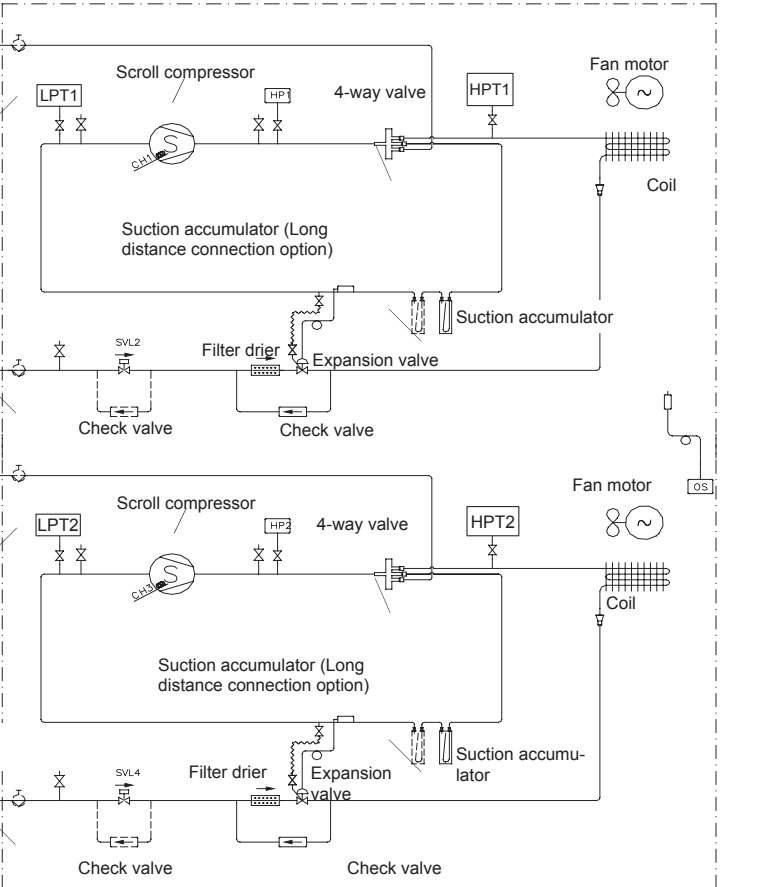

OPTION ELEMENT

	Pressure gauge (5/16" to be fitted by the installer)	HP1	High pressure switch, circuit 1.
DS	Discharge sensor	HP2	High pressure switch, circuit 2.
SVL1	Liquid solenoid valve (long distance option)	CH...	Crankcase heater
SVL3	To be connected by the installer to indoor units.	HPT1	High pressure transducer, circuit 1
SVL2	Liquid solenoid valve (long distance option)	HPT2	High pressure transducer, circuit 2
SVL4	Liquid solenoid valve (long distance option)	OS	Outdoor temperature sensor
LPT1	Low pressure switch, circuit 1		
LPT2	Low pressure transducer, circuit 2		

1. GENERAL CHARACTERISTICS

1.5.- PIPING DRAWINGS HEAT PUMP UNITS

INDOOR UNIT

CIH 100D/120D/140D

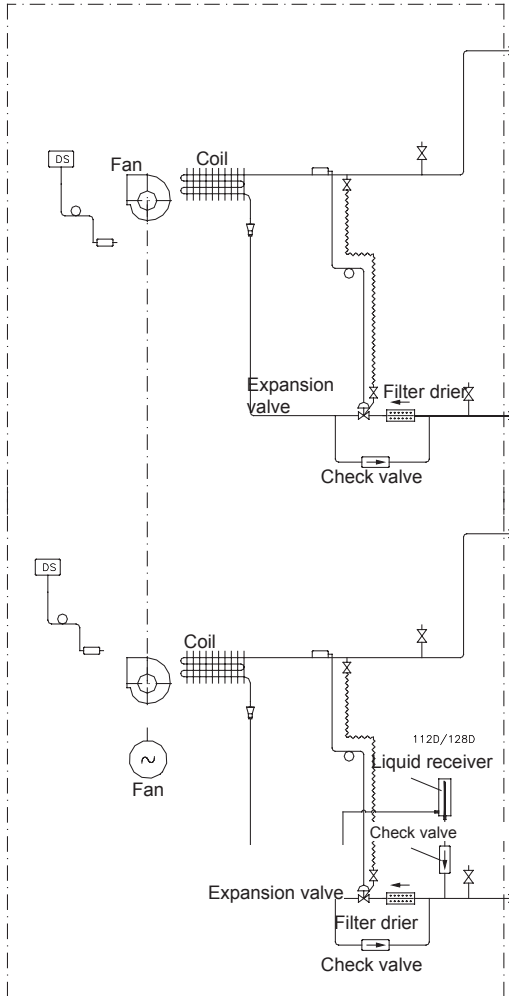

OUTDOOR UNIT

ASH 100D/120D/140D

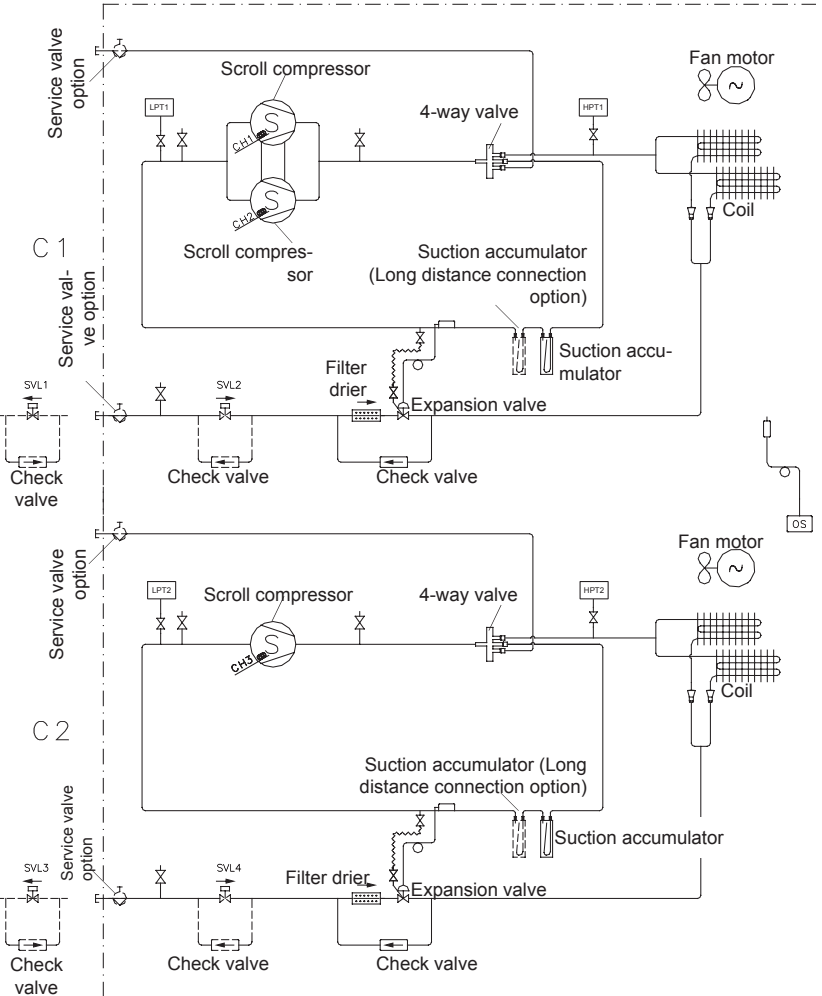

-----OPTIONAL ELEMENT

	Pressure gauge (5/16" to be fitted by the installer)	HP1	High pressure switch, circuit 1.
DS	Discharge sensor	HP2	High pressure switch, circuit 2.
SVL1	Liquid solenoid valve. (long distance option)	CH...	Crankcase heater
SVL3	To be connected by the installer to indoor units.	HPT1	High pressure transducer, circuit 1
SVL2 SVL4	Liquid solenoid valve. (long distance option)	HPT2	High pressure transducer, circuit 2
LPT1	Low pressure switch, circuit 1	OS	Outdoor temperature sensor
LPT2	Low pressure transducer, circuit 2		

1. GENERAL CHARACTERISTICS

1.5.- PIPING DRAWINGS HEAT PUMP UNITS

OUTDOOR UNIT

ASH 200-230D

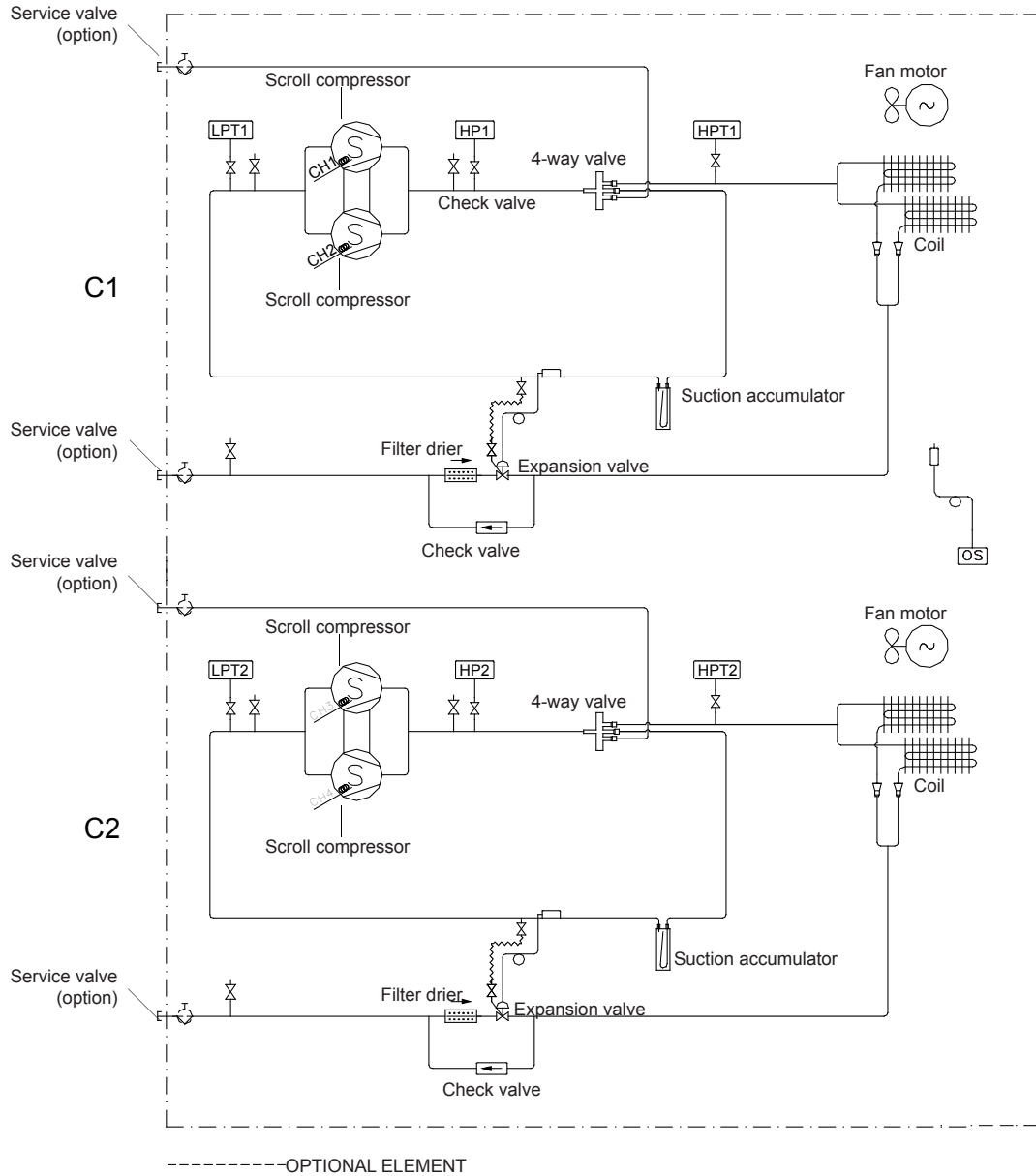

	Pressure gauge (5/16" to be fitted by the installer)	CH...	Crankcase heater (0°C Low ambient option)
LPT1	Low pressure switch Circuit 1	HPT1	High pressure transducer Circuit 1
LPT2	Low pressure switch Circuit 2	HPT2	High pressure transducer Circuit 2
HP1	High pressure switch Circuit 1	OS	Outdoor temperature sensor
HP2	High pressure switch Circuit 2		

1. GENERAL CHARACTERISTICS

1.6.- DIMENSIONS OF ASC/ASH/ADC/ADH UNIT

020S

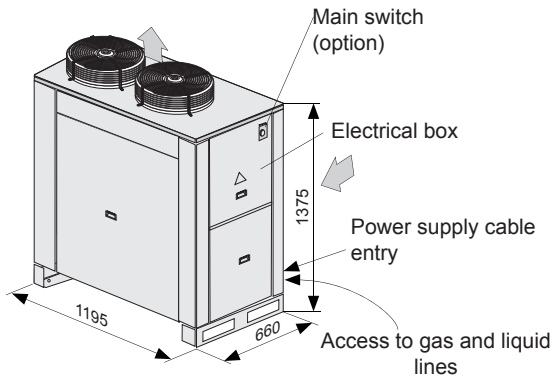

025S/030S/035S/040S

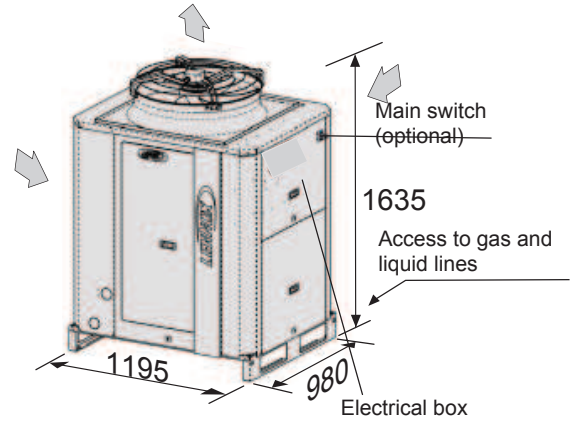

045D/055D/070D/085D

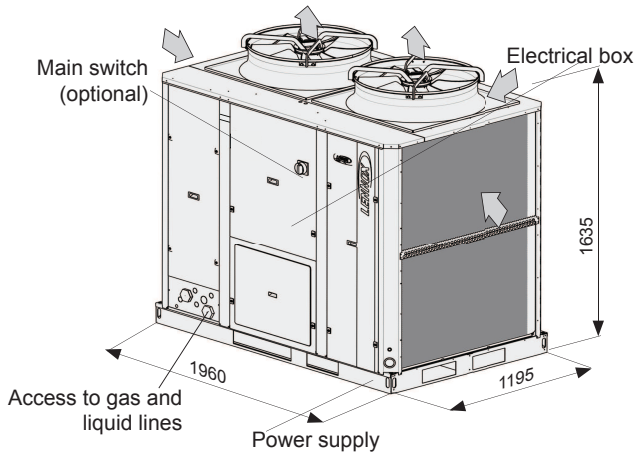

100D/120D/140D

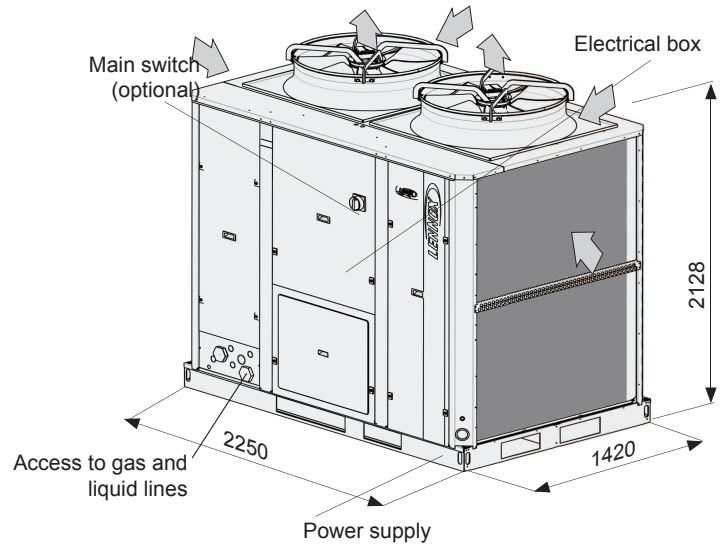

200D-230D

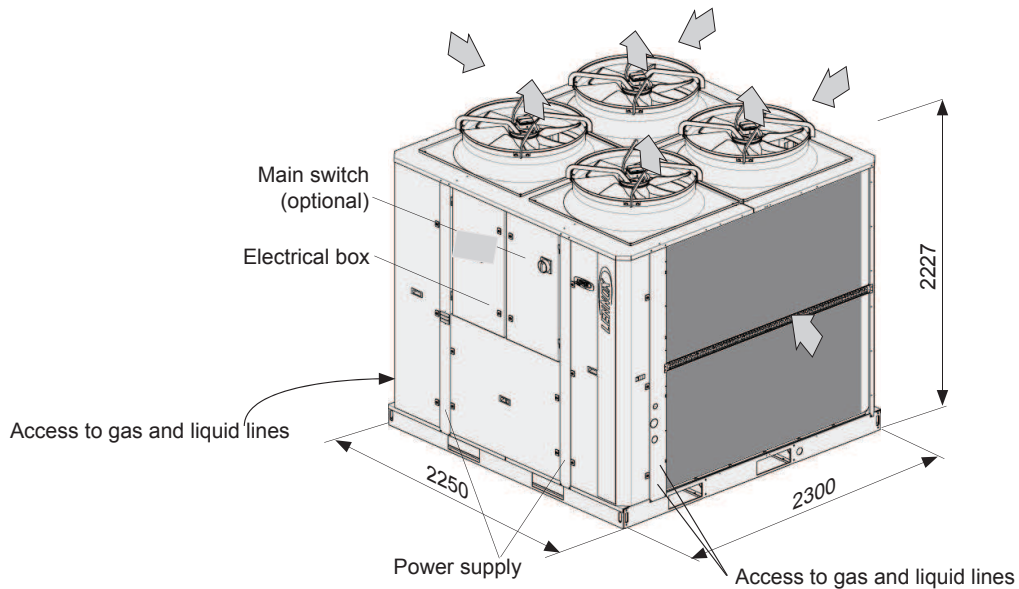

2. INSTALLATION

2.1.- PRELIMINARY PREPATATIONS



All INSTALLATION, SERVICE and MAINTENANCE work must be carried out by QUALIFIED PERSONNEL.

The unit must be transported in a VERTICAL POSITION on its metal mounting frame. Any other position may cause serious damage to the machine. When the unit is received, it should be checked to assure that it has received no shocks or other damage, following the instructions on the packaging. If there is damage, the unit may be rejected by notifying the LENNOX Distribution Department and stating why the machine is unacceptable on the transport agent's delivery note. Any later complaint or claim made to the LENNOX Distribution Department for this type of damage cannot be considered under the Guarantee.

Sufficient space must be allowed to facilitate installation of the unit.

The unit may be mounted outdoors. When the unit is mounted on the floor, ensure that the position is not subject to flooding.



When positioning the unit, be sure that the Rating Plate is always visible since this data will be necessary to ensure correct maintenance.

The units are designed to be installed with ducts designed by qualified technical staff. The joints to be used between ducts and openings in the unit should be Elastic Joints. Avoid the use of BYPASS joints between the extraction air and input air. The structure where the unit is placed must be able to support the weight of the unit during operation.

2.2.- UNIT RECEPTION

How to hoist the unit

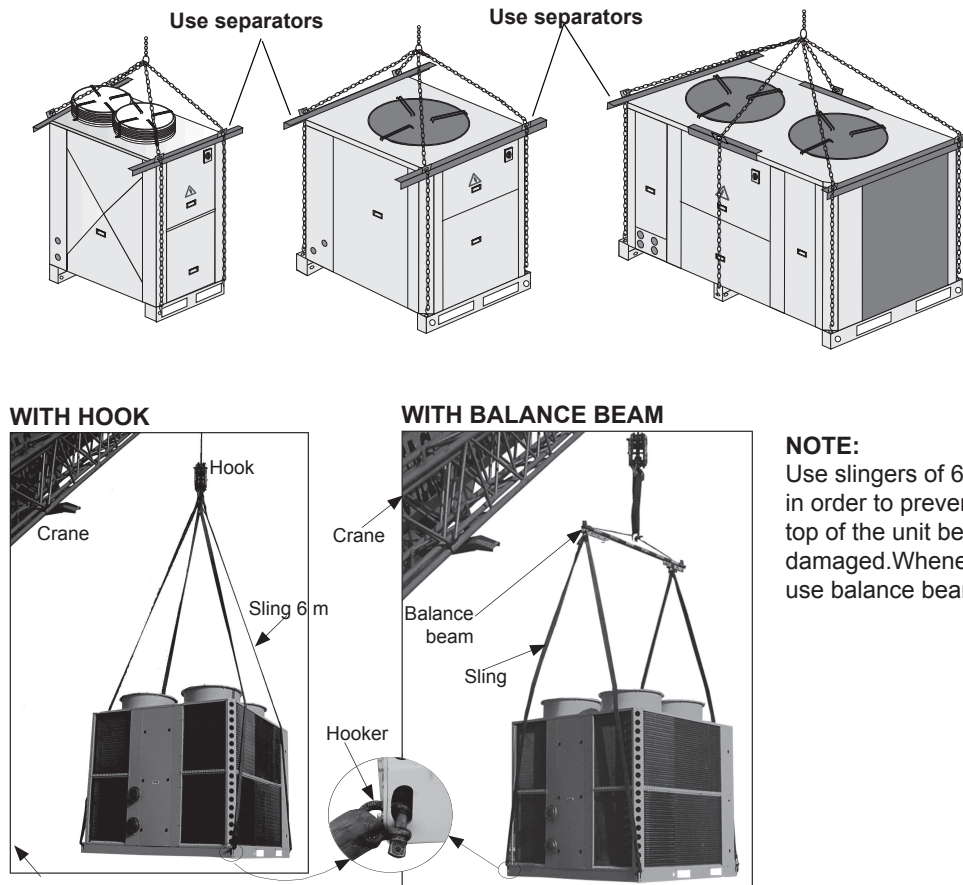

2. INSTALLATION

2.3.- UNIT LOCATION

- The bedplate is made up of metal sections, capable of withstanding the weight of the unit.
- If the unit is floor mounted, then the profiles should be isolated with shock absorbing material such as anti-vibration units or pads. Bear in mind that the fans rotate at approximately 850 rpm.
- The unit is able to work in normal radio interference conditions for commercial and residential installations. For any other conditions please consult us.
- If the outside temperature in the area where the heat pump unit is to be installed is low or the operating cycle is too long, it may be necessary to install an electrical heater in the drip tray, to prevent the formation of ice in the coil during the defrost cycle.

1. Mounting on a low sensitivity area.

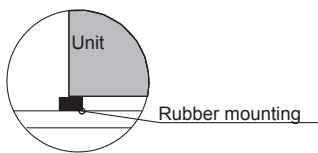

2. Mounting on a medium sensitivity area.

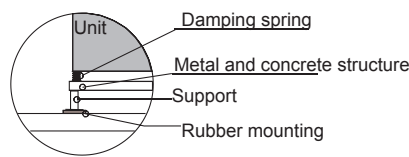

3. Mounting on a high sensitivity area (Check floor loading).

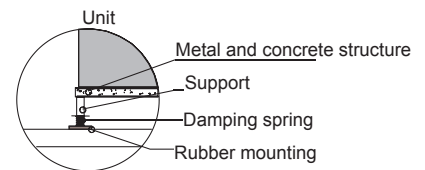

2.4.- INSTALLATION CLEARANCES



FAILURE TO INSTALL THE UNITS AS SHOWN WILL IMPACT PERFORMANCE AND RELIABILITY.

INSTALLATION CLEARANCES

DETAILING AVM POSITIONS

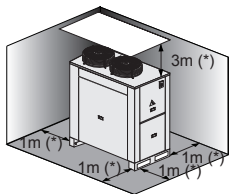

ASC/ASH 020S

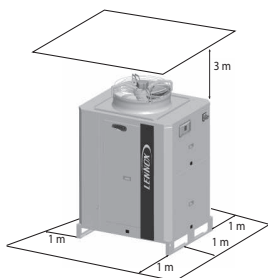
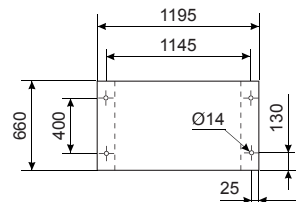

ASC/ASH 025S/030S/035S/040S

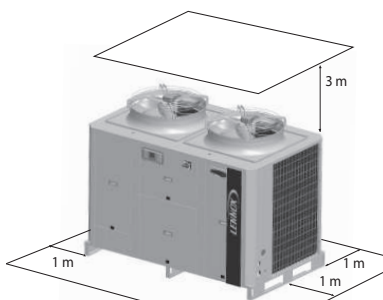
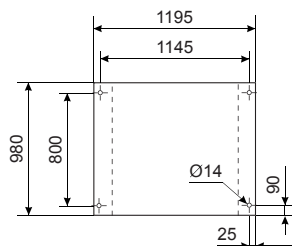

ASC/ASH 045D/055D/070D/085D

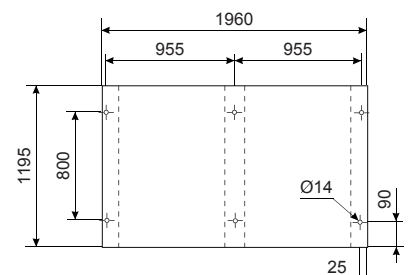

(*) Clearance around the unit.

Size in mm.

2. INSTALLATION

INSTALLATION CLEARANCES

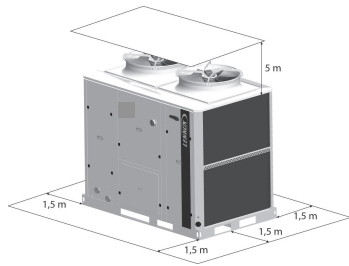

ASC/ASH 100D/120D/140D

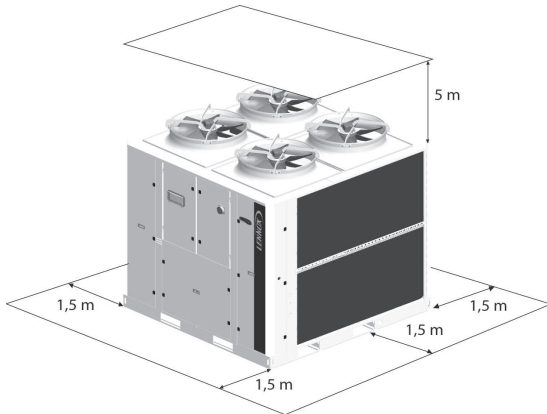

ASC/ASH 200D/230D

(*) Clearance around the unit.

DETAILING AVM POSITIONS

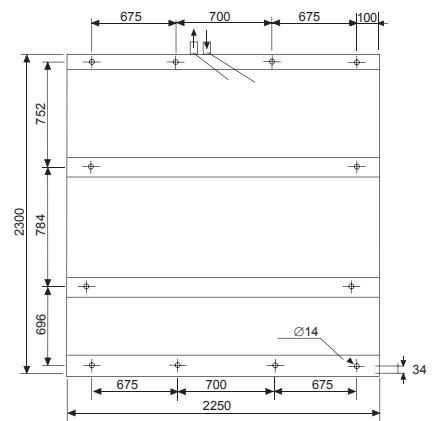
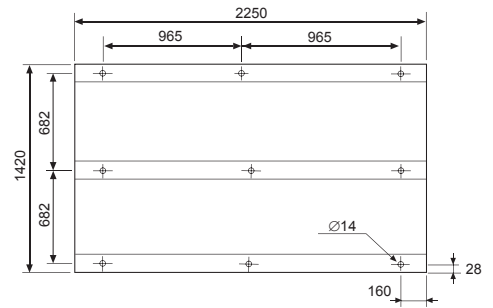

Size in mm.

2.5.- INDOOR LOCATION

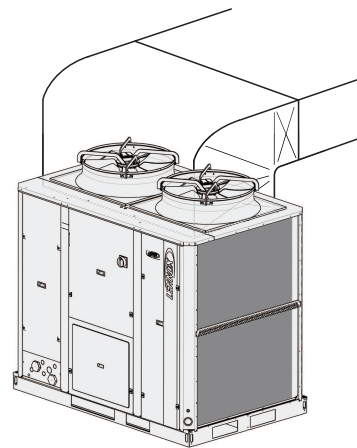
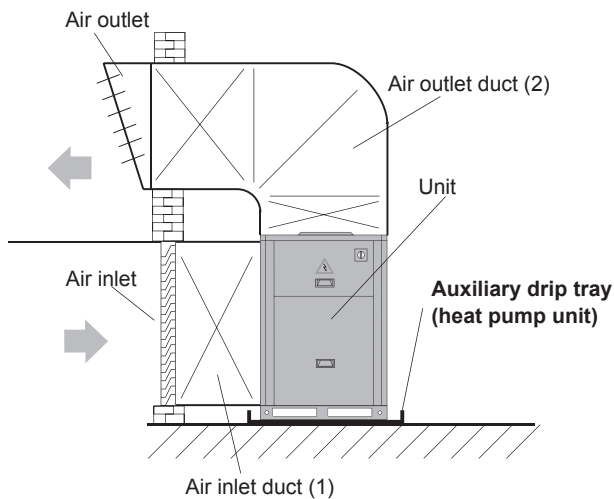

In heat pump units with double circuits and cooling units 100D-140D only, if only one duct is going to be installed, a regulated pressure damper should be installed for each fan, to avoid air by-pass through the fan if it has stopped.

For inside location, keep the following advice in mind:

- During the heat pump defrost cycle, the units produce a large quantity of melted water. If you wish to drain this water, adequate drainage should be installed below the unit to collect and lead the water to the desired location.

- Air duct installation:

If an air duct has been installed, the operating limits will be reduced (see operating limits section in this manual).

- (1) The air intake plenum (option) available for models 100D-140D facilitates the installation of the air intake duct.
- (2) The discharge plenum (option) permits the installation of a square discharge duct with options FP1.

2. INSTALLATION

2.6- REFRIGERANT CONNECTIONS

The unit is supplied with the gas and liquid lines sealed with copper caps outside the casing with possibility to install pipe lines (unless the unit is supplied with the factory precharged refrigerant kit (option) or service valves kit (option)).

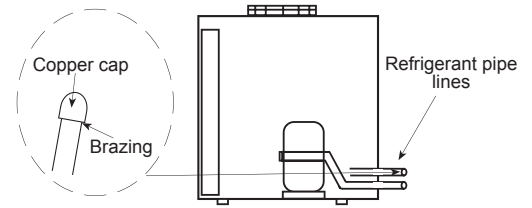

Standard units are filled with Nitrogen gas, which must be removed before any operation on the unit.

As an option, the unit can be supplied with service valves on the gas and liquid lines, with Nitrogen charge (N₂) or refrigerant charge (R-410A).

FOR STANDARD UNITS AND UNITS SUPPLIED WITH SERVICE VALVES PROCEED AS FOLLOW:

1. Remove the nitrogen gas through the high and low 5/16" service ports located inside and provide a low vacuum for safety.
2. Remove the caps from the connecting lines.
3. Braze the piping connection lines. Select piping diameter from TABLE 1.
(When brazing refrigerant pipes, nitrogen gas must be supplied into the pipes through the service ports to remove the air).
4. Leak test:
Add nitrogen gas, check that a pressure of 5 kg/cm² has been reached and that there are no leaks in the circuit or brazing by applying soapy water to the pipes which will cause the bubbles to form where there are leaks.
To detect small leaks, proceed as follows:
Add nitrogen gas and check that a pressure of 25 kg/cm² has been reached, there are no leaks if the pressure remains the same for at least 24 hours and the final pressure is not less than 10% below the initial pressure.
5. Ensure that the gas line is insulated.
6. Evacuation:
Remove the nitrogen gas, connect the gauge manifold and vacuum pump to both the liquid and gas lines, fully open the gauge manifold valve and switch on the vacuum pump. Check to make sure the gauge shows a pressure of -750mm Hg. Once a level of -750mm Hg is reached, keep the vacuum pump running for at least one hour.
7. Refrigerant charge:
 - Check TABLE 3.1. and 3.2. for the amount of refrigerant charge, depending on the length and size of the pipe connections.
 - Disconnect the vacuum pump and connect to the refrigerant-charging bottle. Open the charging pump and purge the air from the hose at the pressure gauge manifold.
 - Set up the amount of additional refrigerant on the weighing scale, open the high pressure and charged in the liquid state. If the total amount of refrigerant charge has not been reached because the pressure is balanced, turn off the high side of the gauge manifold, turn on the unit, and add the remaining amount of the refrigerant charge required slowly through the low side of the pressure gauge. (With R-410A refrigerant, the charging bottle must be in a vertical position and charged in the liquid state). Close the pressure gauge, disconnect it from the from the service port of the unit and fit caps on the service ports. The unit is then ready to operate.



During installation, keep the gas and liquid pipes covered, in order to prevent humidity and dirt from entering them.

**Take special care that the refrigerant pipes are insulated.
Avoid collapse on lines installation.**

FOR UNITS SUPPLIED WITH SERVICE VALVES AND FACTORY PRECHARGED REFRIGERANT KIT, PROCEED AS FOLLOWS:

1. Release the refrigerant pressure from the connecting line through the service port located in that line.
2. Remove the caps from the connecting lines.
3. Braze the interconnection line to the indoor unit.
4. With the service ports closed, evacuate and connect the vacuum pump to the 5/16" service port on the connecting line to achieve a pressure of -750 mm Hg; after that, keep the vacuum pump running for at least one hour in order to provide a vacuum to the connecting lines and the indoor unit. Disconnect the vacuum pump.
5. Refrigerant charge:
Remove vacuum pump and connect the refrigerant bottle. Check TABLE 2 for refrigerant charge per meter of copper pipe for the corresponding model.
Adjust the amount of refrigerant on the weighting scale and open the pressure gauge to charge in liquid state (with R-410A refrigerant, the charging bottle must be in a vertical position and it is important to charge in the liquid state).
Close the pressure gauge, disconnect it from the service port of the unit and fit the caps.
6. Open the service valves.
7. The unit is ready to operate.

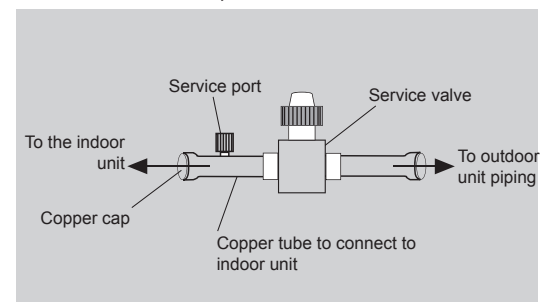

2. INSTALLATION

2.6- REFRIGERANT CONNECTIONS

To locate outdoor and indoor units, refer to the following information:

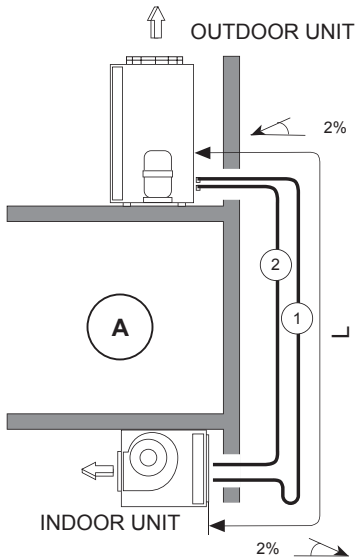

POSITION A: A siphon suction must be installed in the vertical part of the gas line, and siphons must be installed every 8 meters in the rising section. The minimum suction speed must not be below 6m/s. Maximum vertical length 16m.

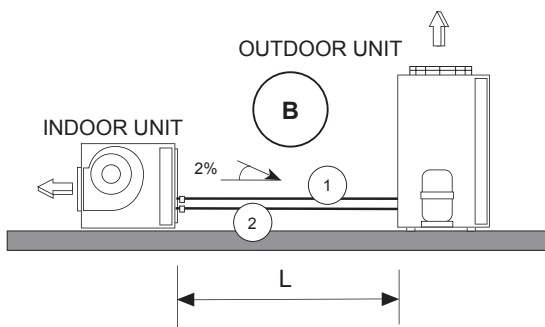

POSITION B: Slope the lines toward the outdoor unit. Take special care with lines longer than 10, and avoid collapse.

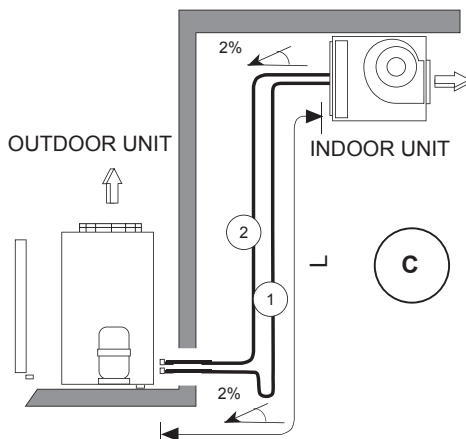

POSITION C: Install a siphon at the base of the vertical of the gas line, no more siphons are necessary. Maximum vertical length 16 m.

A, B, C :	Unit positions
L :	Total length
1 =	Gas line
2 =	Liquid line

NOTE: The units are supplied with welded connections. As an option, service valves are available for liquid and gas lines.

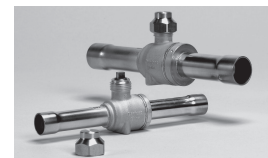

- GAS LINES MUST ALWAYS BE INSULATED.
- THE HORIZONTAL LINES MUST SLOPE AT LEAST 2% TOWARDS THE OUTDOOR UNIT.
- THE MAXIMUM SPEED IN THE LINES, SHOULD NOT BE MORE THAN 15 m/sec.



Legislation does not allow refrigerant gas emissions to the atmosphere, so the refrigerants have to be recycled to avoid being released to the atmosphere. Those recycled refrigerants shall be processed afterwards by an authorized waste manager.

Those components derived from the recycling of the unit have to be managed by authorized waste manager or be left in local waste facilities according the local normative in each country.

2. INSTALLATION

2.6- REFRIGERANT CONNECTIONS

For units with 2 circuits, please be sure to connect indoor unit circuits C1 and C2 to the corresponding C1 and C2 circuits of the outdoor unit.

Note :

MODELS 100D and 120D USE DIFFERENT SIZES OF PIPE CONNECTIONS : LARGE SIZE FOR CIRCUIT 1 AND SMALL SIZE FOR CIRCUIT 2.

TABLE 1: REFRIGERANT LINES SELECTION

REFRIGERANT LINES				Sizes							
				020S	025S	030S	035S	040S	045D	055D	
Total line length. (Length refrigerant lines between indoor unit and outdoor unit.)	0 to 30 m. (Standard connection of unit)	Ø Liquid	C1	1/2"	5/8"	5/8"	5/8"	5/8"	5/8"	5/8"	5/8"
			C2	n/a	n/a	n/a	n/a	n/a	5/8"	5/8"	
		Ø Gas	C1	7/8"	1 1/8"	1 1/8"	1 3/8"	1 3/8"	1 1/8"	1 1/8"	
			C2	n/a	n/a	n/a	n/a	n/a	1 1/8"	1 1/8"	
		Max. nr of bends			6	12	8	18	12	12	8
		30 to 65 m.	Ø Liquid	C1	5/8"	5/8"	5/8"	3/4"	3/4"	5/8"	5/8"
	C2			n/a	n/a	n/a	n/a	n/a	5/8"	5/8"	
	Ø Gas		C1	1 1/8"	1 1/8"	1 3/8"	1 3/8"	1 5/8"	1 1/8"	1 3/8"	
			C2	n/a	n/a	n/a	n/a	n/a	1 1/8"	1 3/8"	
	Max. nr of bends			12	18	18	18	18	18	18	
					070D	085D	100D	120D	140D	200D	230D
	Total line length. (Length refrigerant lines between indoor unit and outdoor unit.)	0 to 30 m. (Standard connection of unit)	Ø Liquid	C1	5/8"	5/8"	3/4"	3/4"	3/4"	7/8"	7/8"
C2				5/8"	5/8"	5/8"	5/8"	3/4"	7/8"	7/8"	
Ø Gas			C1	1 3/8"	1 3/8"	1 5/8"	1 5/8"	1 5/8"	1 5/8"	2 1/8"	
			C2	1 3/8"	1 3/8"	1 3/8"	1 3/8"	1 5/8"	1 5/8"	2 1/8"	
Max. nr of bends				18	12	12	12	12	12	12	
30 to 65 m.			Ø Liquid	C1	3/4"	3/4"	7/8"	7/8"	7/8"	n/a	n/a
		C2		3/4"	3/4"	3/4"	3/4"	7/8"	n/a	n/a	
		Ø Gas	C1	1 3/8"	1 5/8"	1 5/8"	1 5/8"	1 5/8"	n/a	n/a	
			C2	1 3/8"	1 5/8"	1 5/8"	1 5/8"	1 5/8"	n/a	n/a	
		Max. nr of bends			18	18	12	12	12	n/a	n/a

n/a: not available



With lines length between 40 and 65 m, long distance option must be selected.



Units are factory pre-charged with Nitrogen (N₂).
The installer should remove the nitrogen and charge the units with the R-410A refrigerant shown in the following tables and also the charge per meter of line shown in TABLE 2.

The unit is supplied as standard with brazed connections. A factory pre-charged kit is available as an option. If fitted, TABLE 2 is the only one to take into account (this option includes service valves).

TABLE 2: WEIGHT OF R-410A REFRIGERANT PER METER OF LINE g/m

LIQUID	GAS	
1/2"	7/8"	108
5/8"	1-1/8"	177
5/8"	1-3/8"	182
3/4"	1-3/8"	265
3/4"	1-5/8"	271
7/8"	1-5/8"	374

2. INSTALLATION

2.6- REFRIGERANT CONNECTIONS

TABLE 3.1 : REFRIGERANT CHARGE

Charge of refrigerant (gr) R-410A for 0 meters of line ASC + indoor unit (Cooling only)														
	020S	025S	030S	035S	040S	045D	055D	070D	085D	100D	120D	140D	200D	230D
C1	5155	5315	5700	7950	9745	6250	5775	7870	9800	12130	15585	15500	23100	24250
C2	-----	-----	-----	-----	-----	6250	5775	7870	9800	10450	10045	15400	23100	24250

Charge of refrigerant (gr) R-410A for 0 meters of line ASH + indoor unit (Heat pump)														
	020S	025S	030S	035S	040S	045D	055D	070D	085D	100D	120D	140D	200D	230D
C1	5725	5900	6330	8835	10830	6940	6420	8740	10900	13480	17315	17230	25660	26950
C2	-----	-----	-----	-----	-----	6940	6420	8740	10900	11600	11160	17100	25660	26950

Note :

MODELS 100D and 120D USE DIFFERENT SIZES OF PIPE CONNECTIONS : LARGE SIZE FOR CIRCUIT 1 AND SMALL SIZE FOR CIRCUIT 2.

REFRIGERANT CHARGE FOR THE SET:

EXAMPLE:

To install a ASH 030S + CIH 030S set, with 22 m refrigerant line length between the outdoor and indoor units, the refrigerant charge must be calculated as follows:

- TABLE 1 (p. 20) shows that for 22m of line length between the indoor unit and outdoor units, the line sizes are: liquid 5/8" and gas 1 1/8".
- TABLE 2 (p. 20) shows, for line sizes of 5/8"-1 1/8", the charge per meter of line is: 177 g/m x 22m = 3894 g.
- TABLE 3.1 shows charge of refrigerant for a set with 0m line length is: 6330 g.
- To determine the charge of the set:

Add the charge in the refrigerant lines + the charge in the indoor unit and outdoor refrigerant units.

$$\text{Total charge for the set: } 3894 + 6330 = 10224 \text{ g}$$

Note: If the outdoor unit includes the factory pre-charged kit, only the weight of refrigerant per meter of line in TABLE 2 is taken into account.

100D to 140D units with 3 compressors are working using three capacity steps and 200D-230D with 4 capacity steps.

See the picture below for the installation in the case of units with tandem compressor circuit. An additional gas line has to be used to assure the correct operation of the system.

Condensing unit with capacity reduction

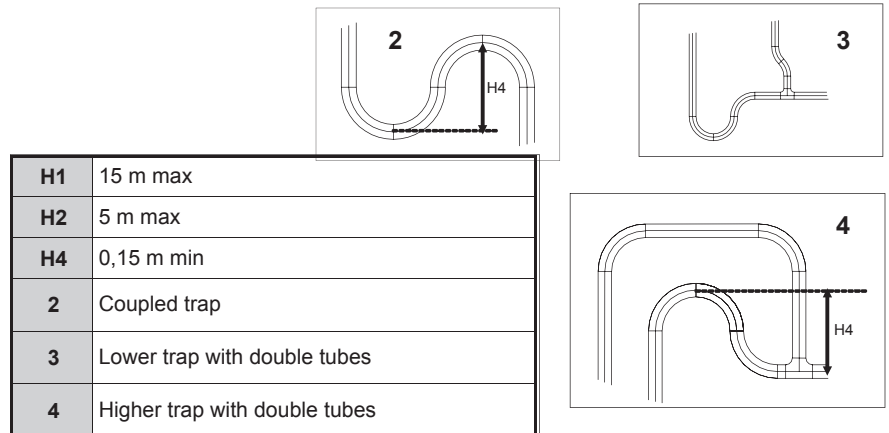
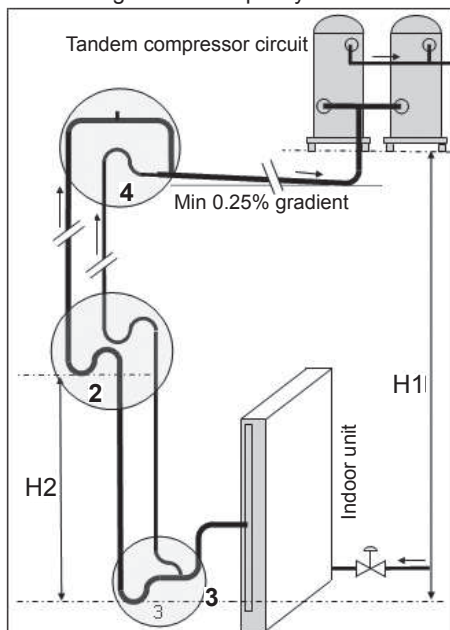

Models with tandem compressor

100D	120D	140D	200D	230D
Circuit 1	Circuit 1	Circuit 1	Circuits 1 & 2	Circuits 1 & 2

2. INSTALLATION

2.7.- ELECTRICAL CONNECTIONS



- BEFORE MAKING ANY ELECTRICAL CONNECTIONS, ENSURE THAT ALL CIRCUIT BREAKERS ARE OPEN.
- IN ORDER TO MAKE THE ELECTRICAL CONNECTIONS, FOLLOW THE ELECTRICAL DIAGRAM SUPPLIED WITH THE UNIT.

INDOOR SECTION

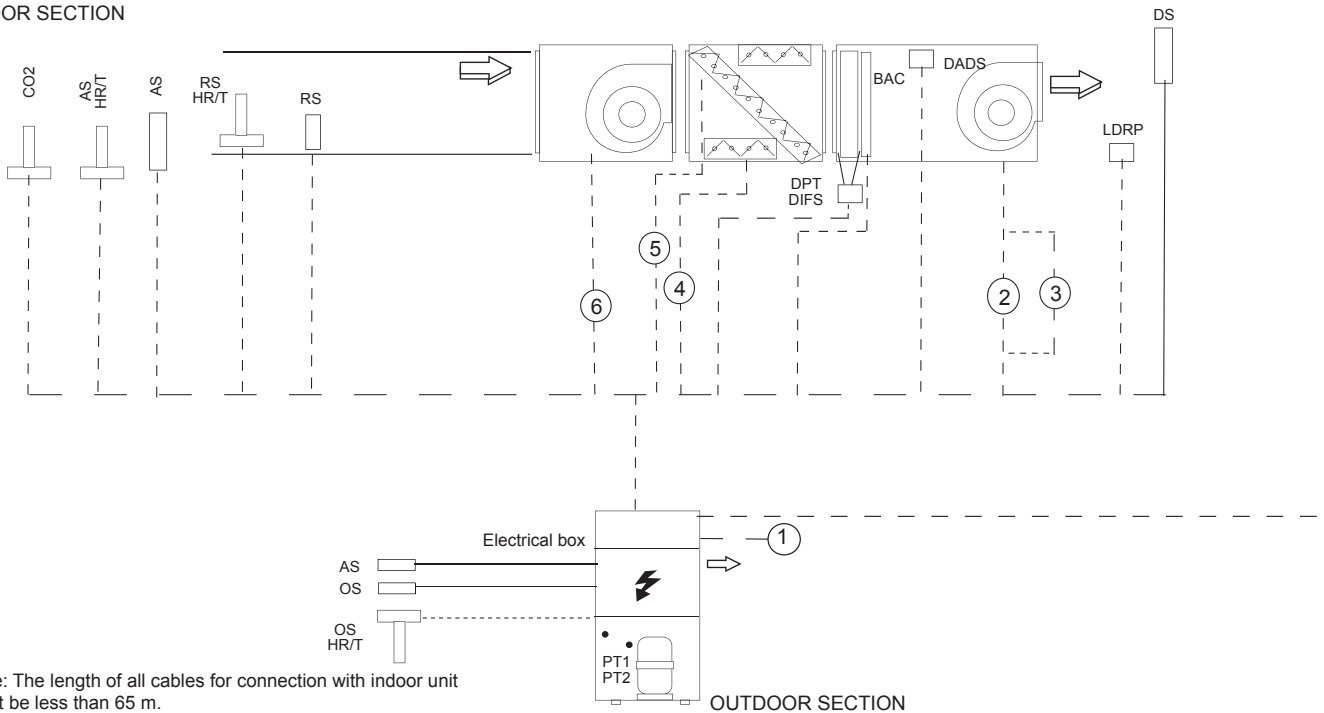

Note: The length of all cables for connection with indoor unit must be less than 65 m.

OUTDOOR SECTION

----- To connect by installer

CONNECTION OF CONTROL ELEMENTS:

COMPONENT		Split unit	Condensing unit	
DS	Discharge sensor	STANDARD	N/A	2 x 1 mm ² (shielded)
OS	Outdoor sensor		STANDARD	
AS	Remote ambient sensor			
RS	Remote duct sensor	OPTION	N/A	6G x 1 mm ² (shielded)
RS HR/T	Duct remote sensor for enthalpic free-cooling			4 x 1 mm ² (shielded)
CO2	CO2 Air quality probe. (Available only with enthalpic free-cooling)			3 x 1 mm ² (shielded)
DPT	Air differential pressure transducer			5 x 1 mm ² (shielded)
OS HR/T	Outdoor sensor for enthalpic free-cooling			6G x 1 mm ² (shielded)
AS HR/T	Remote ambient sensor for enthalpic free-cooling			2 x 1,5 mm ²
DIFS	Dirty filter sensor			3 x 1,5 mm ² (units 1 circuit) 2 x (3 x 1,5 mm ²) (units 2 circuits)
LDRP	Long distance connection			7 x 1,5 mm ²
DADS	Smoke detector			5 x 1,5 mm ²
BAC	Hot water coil			

VOLTAGE OPERATING LIMITS: 342-462V

2. INSTALLATION

2.7.- ELECTRICAL CONNECTIONS

POWER SUPPLY

Power supply								
	Power supply	Power supply with electrical heater	Fan	Free-cooling	Exhaust fan	Return fan		
	1	1'	2	4	5	6		
020S	5G x 4 mm ²	5G x 16 mm ²	4G x 1,5 mm ² (STD/HP1) & (HP2/HP3)	6G x 1,5 mm ²	4G x 1,5 mm ²	N/A		
025S	4G x 6 mm ²	4G x 16 mm ²						
030S								
035S	4G x 10 mm ²	3 x 35 mm ² + 1 x 16 mm ²						
040S								
045D	4G x 16 mm ²	3 x 50 mm ² + 1 x 25 mm ²						
055D								
070D	3 x 25 mm ² + 1 x 16 mm ²	3 x 70 mm ² + 1 x 35 mm ²					4G x 1,5 mm ² (STD/HP1) 4G x 2,5 mm ² (HP2/HP3)	4G x 1,5 mm ²
085D								
100D	3 x 50 mm ² 1 x 25 mm ²	3 x 95 mm ² + 1 x 50 mm ²					4G x 2,5 mm ² (STD/HP1) 2 x (4G x 1,5 mm ²) (HP2/HP3)	4G x 2,5 mm ²
120D								
140D								
200D	3 x 70 mm ² + 1 x 35 mm ²	N/A	N/A	N/A	N/A	N/A		
230D	3 x 95 mm ² + 1 x 50 mm ²	N/A	N/A	N/A	N/A	N/A		

n/a: not available

Power supply				
Electrical heater (3)				
	Standard - ELHS	Medium - ELHM	High - ELHH	Modulating - EHHM
020S	4G x 2,5 mm ² + 6G x 1,5 mm ²	4G x 6 mm ² + 6G x 1,5 mm ²	4G x 10 mm ² + 6G x 1,5 mm ²	4G x 10 mm ² + 7G x 1,5 mm ²
025S				
030S				
035S	4G x 6 mm ² + 6G x 1,5 mm ²	4G x 10 mm ² + 6G x 1,5 mm ²	4G x 25 mm ² + 6G x 1,5 mm ²	4G x 25 mm ² + 7G x 1,5 mm ²
040S				
045S				
055D				
070D				
085D				
100D	4G x 10 mm ² + 6G x 1,5 mm ²	4G x 10 mm ² + 6G x 1,5 mm ²	4G x 25 mm ² + 6G x 1,5 mm ²	4G x 25 mm ² + 7G x 1,5 mm ²
120D				
140D				
200D				
230D	N/A	N/A	N/A	N/A

n/a: not available

2. INSTALLATION

2.7.- ELECTRICAL CONNECTIONS

COMFORT AND SERVICE TERMINAL CONNECTION

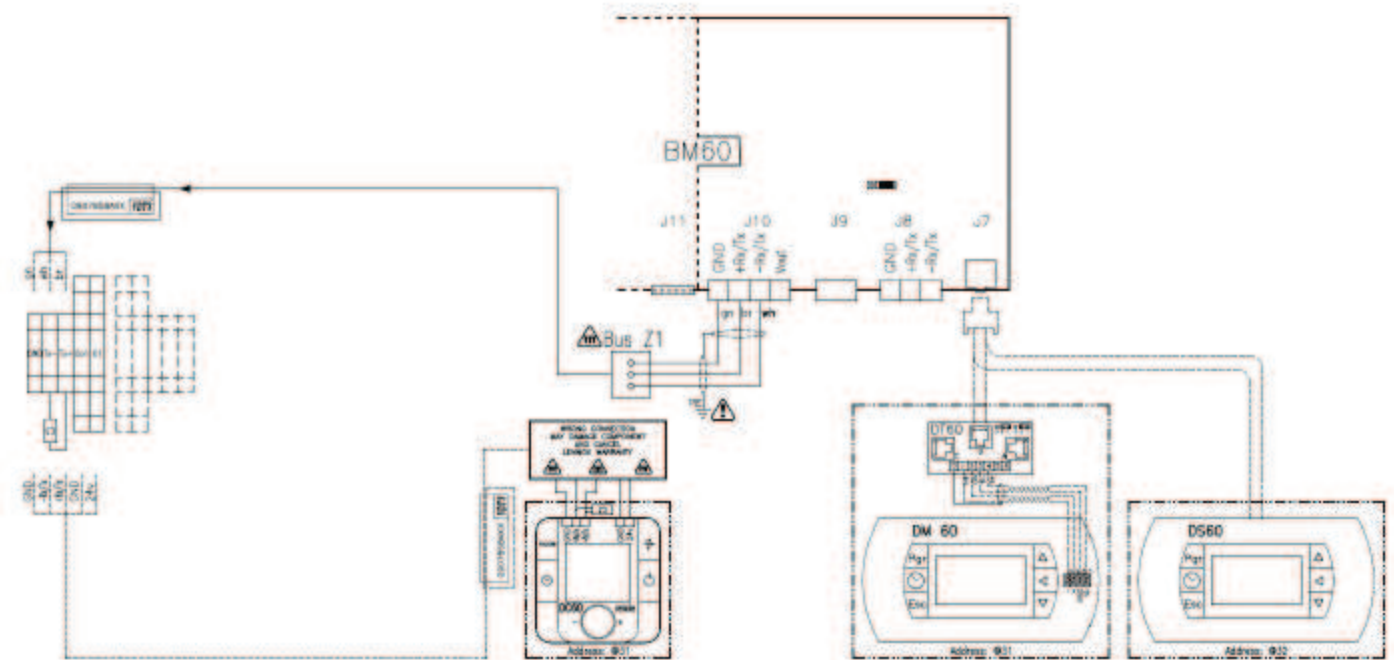

2.8.- DRY CONTACT BOARD CONTROL

The AIRCOOLAIR condensing unit can be remotely controlled via dry contacts on the BM60 and BE60. The expansion board BE60 is an additional board fixed on DIN rail. This board is supplied in stand on AIRCOOLAIR condensing unit.

Description of the various connectors :

- 1 Power supply of the board
- 2 Analog output 0/10V : not used
- 3 Network bus to the CLIMATIC 60 BM60
- 4 4 digital inputs : dry contacts only
- 5 LED status of the network bus
- 6 Serial address dip-switch of the network bus
- 7 4 analog input configurable by pair B1-B2 and B3-B4
- 8 4 digital outputs : dry contact only

6 digital inputs are dry contacts. They are factory configured as follow :

2 inputs on the BM60

- BM-J4-ID4 : TCB B = Cooling/Heating - Contact closed = the unit operates in heating mode and open contact = the unit operates in cooling mode
- BM-J4-ID7 : TCB G = On/Off - Contact closed = On.

4 inputs on the BE60

- BE-J4-ID1 : TCB Y1 = 50% power engaged when the contact is closed
- BE-J4-ID2 : TCB Y2 = 100% power engaged when the contact is closed
- BE-J4-ID3 : Available
- BE-J4-ID4 : Available

2. INSTALLATION

2.9 - OPTIONS INSTALLATION

COMMUNICATION CAPABILITIES

1. BMS MODBUS_RS485 or TCP/IP connection.
2. BMS LONWORKS_Echelon connection.
3. BMS BACnet - RS485 or TCP/IP connection.

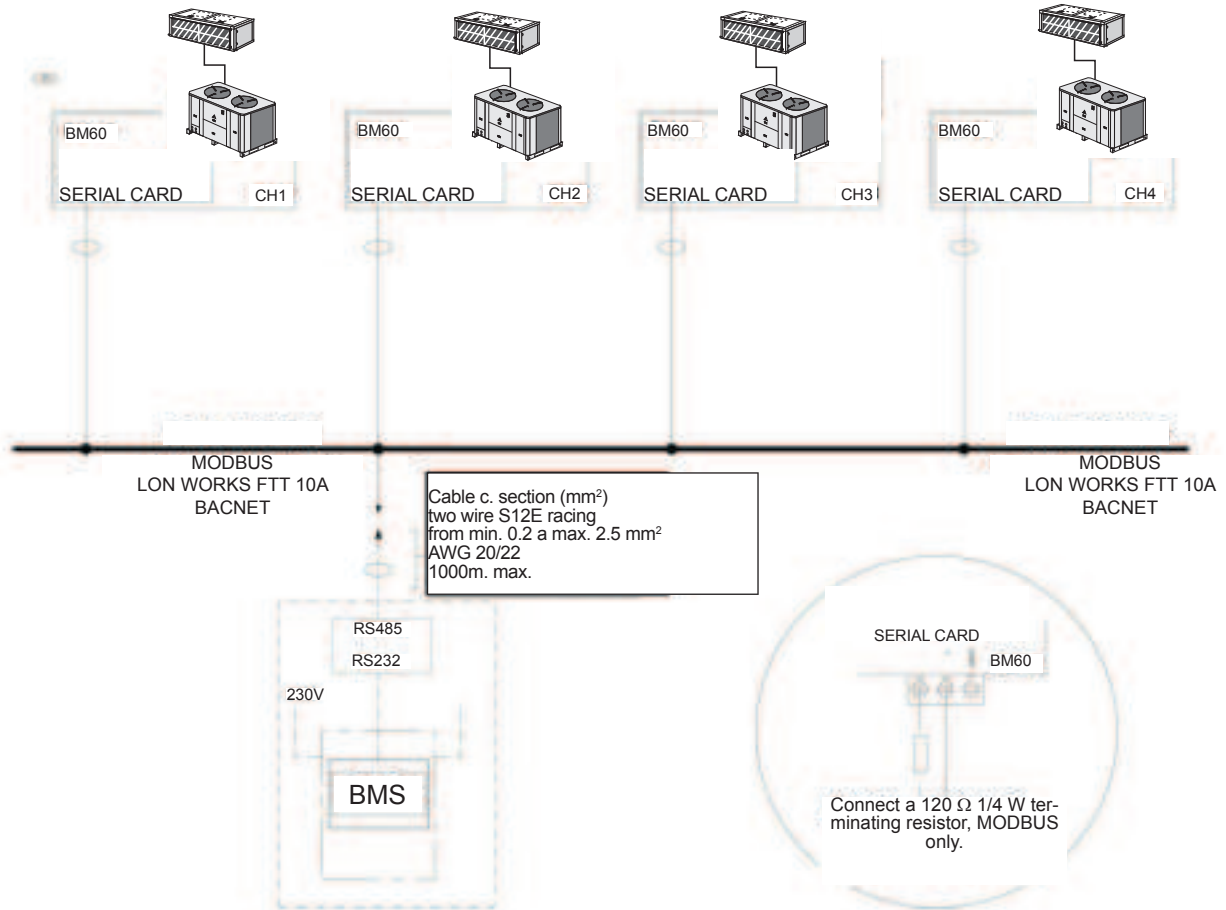

A master-slave connection is possible :

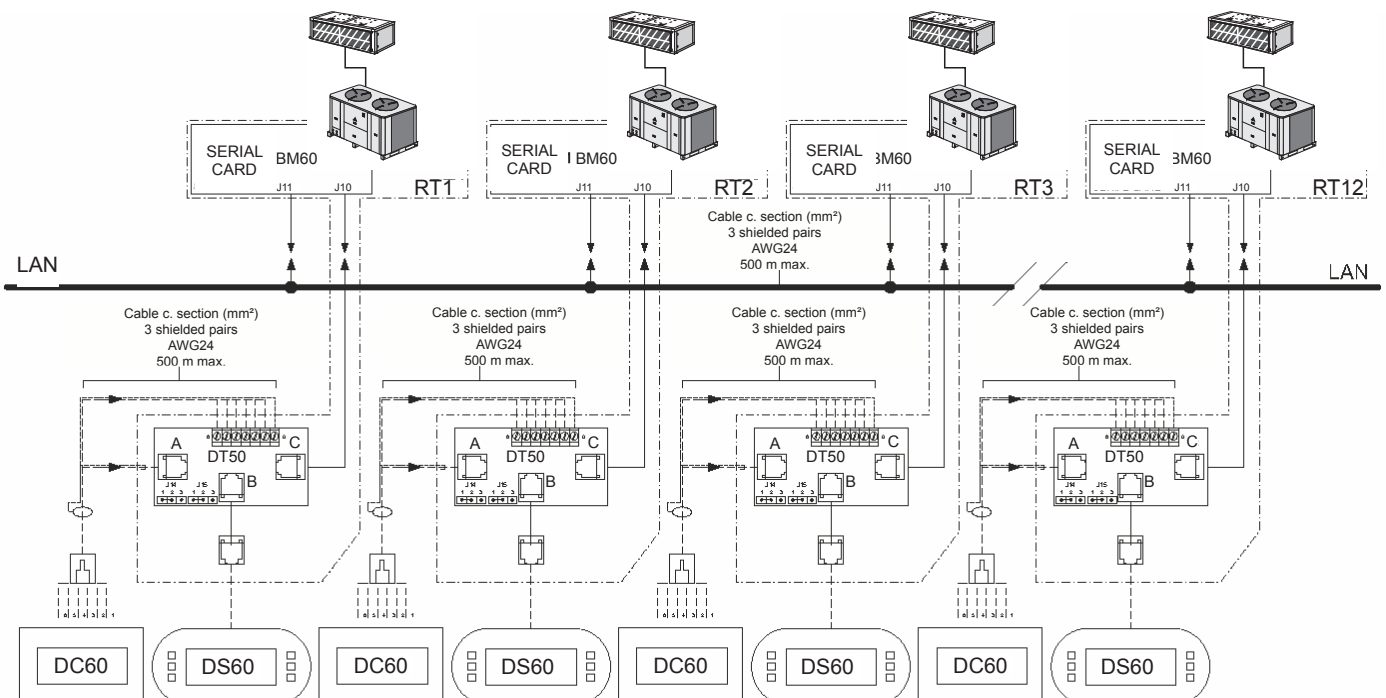

3. COMMISSIONING AND OPERATION

3.1.- PRELIMINARY CHECKS BEFORE STARTUP

- Check that the **power supply** is the same as stated on the Rating Plate which is in agreement with the electrical diagram for the unit and that cable sizes are correct.
- Check that **tightness of the electrical connections to their terminals and to ground.**
- Check the **control panel connections.**
(If the connection is incorrect, the unit will not operate and the control panel display will not light).
- Check with your hand that the **fans are turning freely.**

FIGURE FOR THE STANDARD UNIT CONFIGURATION FOR MODELS:
045D-055D-070D-085D

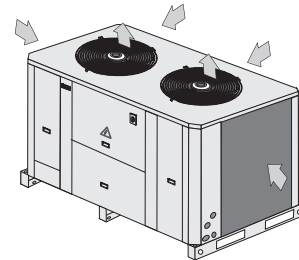

CHECK COMPRESSOR OIL LEVEL

- Part of the compressor oil is pumped to the system when the compressor starts, so for split systems part of the oil can be placed in the system: piping lines, traps, evaporator, etc.
- The quantity of oil in the system depends on the refrigerant charge. The compressor cannot work with incorrect or excessive refrigerant.
- It may be necessary to add oil to the system, depending on the piping length.
- See below an example of calculation of the oil quantity to be added to the system.

EXAMPLE:

ASH 030S + CIH 030S with 65 m. (with remote option).

- Refrigerant charge = 6.33 kg (TABLE 3.1, p. 21).
- Refrigerant charge to add with 65 m = $182\text{g/m} \times 65 = 11.83\text{kg}$. (TABLE 2, p. 20).
- Total refrigerant charge = $6.33 + 11.83 = 18.16$ kg.
- Oil compressor charge (l) = 3.25
- Oil compressor charge (kg) = 2.925 (density = 0.9).
- Permissible quantity in the system (kg) = 0.03 (= 2.925×0.01).
- Permissible refrigerant charge (kg) = 6 (= $0.03 / 0.005$).
- Excess refrigerant charge = $18.16 - 6 = 12.16$
 60.8 g (= 12.16×5 g) quantity of oil to be added to the system.
0.55 l of oil to be added to the system.

In the event of having to add oil, remember the type of oil is synthetic POE.

The original oil charge, including the compressor, is ICI Emkarate RL32-3MAF. This type of oil must also be used when replacing the oil completely.

If only topping up, RL32-3MAF or Mobil EAC Artic 22C can be used.

3. COMMISSIONING AND OPERATION

3.2.- PRELIMINARY CHECKS AT STARTUP

To start the unit, **follow the instructions given in the User Manual for the control** supplied with the unit (requiring operation in any of the modes, cooling, heating, or automatic).

After a time delay, the unit will start.

With the unit operating, check that the **fans are turning freely and in the correct direction.**

CHECK THAT THE COMPRESSOR IS ROTATING IN THE CORRECT DIRECTION

- If you have the option phase rotation indicator, use it to check the correct rotation.
- If you do not have three phase return lock, check the correct direction of rotation. The suction pressure decreases and the discharge pressure increases when the compressor is started.
- If the connection is incorrect, rotation will be reversed, causing a high noise level and a reduction in the amount of current consumed. If this occurs, the compressor's internal protection system will operate to shut down the unit. The solution is to disconnect, reverse two of the phases and connect again.

ASTP Protection is included with the unit compressors. See "Fault diagnosis" for more information.

WITH OPERATING UNIT, CHECK:

- Low pressure and high pressure.
- Use the evaporating and liquid temperature to calculate superheat and subcooling.
- Adjust the refrigerant charge and/or expansion valve according to the preceding values.

COMPRESSOR OIL LEVEL

The oil level must always be checked. When the compressor is at rest, the level should be between 1/4 and 3/4 in the sight glass, while when running the level should be between 3/4 and full.

In the event of having to add oil, remember the type of oil is synthetic POE.

The original oil charge in the compressor is ICI Emkarate RL32-3MAF. This type of oil must also be used when replacing the oil completely.

When only topping up, RL32-3MAF or Mobil EAC Artic 22C can be used.



The unit must be installed in accordance with local safety codes and regulations and can only be used in a well ventilated area. Please read carefully the manufacturer's instructions before starting this unit

All work on the unit must be carried out by a qualified and authorised employee.

Non-compliance with the following instructions may result in injury or serious accidents.

Work on the unit:

The unit shall be isolated from the electrical supply by disconnection and locking using the main isolating switch. Workers shall wear the appropriate personal protective equipment (helmet, gloves, glasses, etc.).

Electrical system:

Electrical connections can become loose during transport. Please check them before starting-up the unit Compressors with specific rotation direction. Check the correct rotation direction of the fan before closing the compressor circuit breakers. If the direction is incorrect, the phases must be reversed at the head of the main switch. Work on electric components shall be performed with the power off (see below) by employees having valid electrical qualification and authorisation.

Refrigerating circuit(s):

After more than 12 hours of power cut, the crankcase heater (compressor) should be powered for 5 hours before any return to service. Non-compliance with this instruction can cause deterioration of the compressors.

Monitoring of the pressures, draining and filling of the system under pressure shall be carried out using connections provided for this purpose and suitable equipment.

To prevent the risk of explosion due to spraying of coolant and oil, **the relevant circuit shall be drained and at zero pressure before** any disassembly or unbrazing of the refrigerating parts takes place. There is a residual risk of pressure build-up by degassing the oil or by heating the exchangers after the circuit has been drained. **Zero pressure shall be maintained** by venting the drain connection to the atmosphere on the low pressure side.

The brazing shall be carried out by a qualified brazier. The brazing shall comply according to code ASME section IX following the procedures specific.

Before starting up

- Test the circuit to the maximum working pressure (see the nameplate)
- Verify the operation of the high pressure switch.
- Check the piping and the components of the refrigerant circuit.

Replacing components:

In order to maintain CE marking compliance, replacement of components shall be carried out using spare parts, or using parts approved by Lennox. Only the coolant shown on the manufacturer's nameplate shall be used, to the exclusion of all other products (mix of coolants, hydrocarbons, etc.).

CAUTION:

In the event of fire, refrigerating circuits can cause an explosion and spray coolant gas and oil.



4. MAINTENANCE

4.1.- PREVENTIVE MAINTENANCE



PREVENTIVE MAINTENANCE PREVENTS COSTLY REPAIRS. THIS REQUIRES PERIODIC INSPECTIONS:

GENERAL STATE OF THE CASING:

Furniture, paint, damage due to shocks, rust spots, levelling and supporting, condition of the shock absorbers, if installed, screwed panels, etc.

ELECTRICAL CONNECTIONS:

State of hoses, tightness of screws, earthing, current consumption of the compressor and fans and check that the unit is receiving the correct voltage.

COOLING CIRCUIT:

Check that the pressures are correct and that there are no leaks. Check that there is no damage to the pipe insulation, that the condition of the coils is good and that they are not blocked by bits of paper or plastic drawn in by the air flow, etc.

COMPRESSOR:

If a sight glass is fitted, check the oil level.
Check the condition of the silentbloc mountings.

FANS:

Check that fans turn freely and in the correct direction without excessive noise.

CONTROL:

Check Set Points and normal operation.

4.2.- CORRECTIVE MAINTENANCE



IMPORTANT

MAKE SURE THAT THE UNIT IS FULLY DISCONNECTED FROM THE POWER SUPPLY WHEN CARRYING OUT ANY TYPE OF WORK ON THE MACHINE.

If any **component** in the cooling circuit **is to be replaced**, follow these recommendations:

- Always **use original replacement parts**.
- If the component can be isolated, it is not necessary to remove the entire **refrigerant charge**, if the component cannot be isolated and the refrigerant charge is removed, it should be removed through the Schrader valves located in the outdoor section. Create a slight vacuum as a safety measure.
- Regulation **prohibits the release of refrigerant into the atmosphere**.
- If cuts must be made in the pipe work, use pipe cutters. **Do not use saws or any other tools that produce filings**.
- **All brazing must be carried out in a nitrogen atmosphere** to prevent corrosion forming.
- Use **silver alloy brazing rod**.
- **Take special care that the flame** from the torch is directed away from the component to be welded and cover with a wet rag to prevent overheating.
- **Take very special care if 4-way or check valves are to be replaced** since these have internal components that are very heat-sensitive such as plastic, teflon, etc.
- If a **compressor is to be replaced**, disconnect it electrically and un-braze the suction and discharge lines. Remove the securing screws and replace the old compressor with the new one. Check that the new compressor has the correct oil charge, screw it to the base and connect the lines and electrical connections.
- **Evacuate above and below through the Schrader valves** of the outdoor unit until -750 mm Hg is reached. Once this level of vacuum has been reached, keep the pump running for at least one hour.
DO NOT USE THE COMPRESSOR AS A VACUUM PUMP.
- **Charge the unit with refrigerant** according to the data on the Rating Plate for the unit and **check that there are no leaks**.

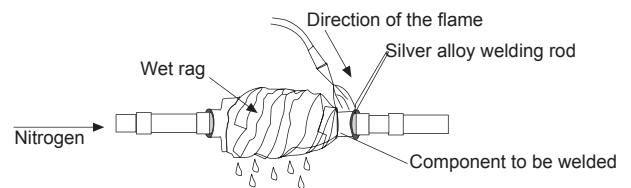

PRECAUTIONS TO BE TAKEN WHEN USING OF R-410A Refrigerant:

R-410A refrigerant is used in the unit; the following standard precautions for this gas should therefore be taken:

- The Vacuum Pump must have a Check Valve or Solenoid Valve fitted.
- Pressure Gauges and Hoses for exclusive use with R-410A Refrigerant should be used.
- Charging should be carried out in the Liquid Phase.
- Always use scales to weigh-in charge
- Use the Leak Detector exclusive for R-410A Refrigerant.
- Do not use mineral oil, only synthetic oil to ream, expand or make connections.
- Keep pipes wrapped before using them and be very thorough about any possible dirt (dust, filings, burrs, etc.).
- When there is a leak, collect what remains of the charge, create a vacuum in the unit and completely recharge with new R-410A Refrigerant.
- Brazing should always be carried out in a nitrogen atmosphere.
- Reamers should always be well sharpened.

4. MAINTENANCE

4.3.- FAULT DIAGNOSIS

In case of failure or malfunction of the unit, the display on the control panel will show an error or alarm warning which is explained in the control panel manual. Nevertheless, whenever there is a unit fault, the unit should be shut down and our service technicians consulted.

FAULT	POSSIBLE CAUSES	POSSIBLE SOLUTIONS
UNIT DOES NOT START	Fault in the power supply or insufficient voltage.	Connect the power supply or check the voltage.
	Circuit breakers have opened.	Reset.
	Power cable or control panel cable is defective.	Inspect and correct.
UNIT STOPS DUE TO HIGH PRESSURE DURING THE COOLING CYCLE	High pressure switch is defective.	Check cut-off pressure switch or replace pressure switch if necessary.
	Outdoor fan is not working.	Check for voltage, inspect the motor and turbine or replace if necessary..
	Outdoor fan turns in the wrong direction.	Reverse the power phases.
	Outdoor coil is dirty or clogged for passing air.	Inspect and clean.
	Excess refrigerant charge.	Remove the charge and charge according to the data on the rating plate.
UNIT STOPS DUE TO HIGH PRESSURE DURING THE HEATING CYCLE	The same causes and solutions as the cold cycle but with reference to the coils and indoor fan.	
UNIT STOPS DUE TO LOW PRESSURE	Low pressure switch defective.	Check the cut-off pressure with a pressure gauge and replace the pressure switch if necessary.
	Indoor fan is not working.	Check for voltage and inspect the motor, turbine and replace if necessary.
	Indoor fan turns in the wrong direction.	Reverse the power phases.
	Lack of refrigerant. Leak.	Correct leak, create vacuum and charge.
	Dirty air filter.	Inspect and clean
	Clogged cooling circuit. Dirty filter drier.	Inspect and correct or change the filter drier.
UNIT STARTS AND STOPS IN SHORT CYCLES	Compressor overcharged.	Inspect suction and discharge pressure values and correct.
	Compressor cuts off due to Klixon.	Check input voltage and voltage drop.
	Lack of refrigerant.	Correct leak and replace.
LOAD AND ABNORMAL NOISE IN THE COMPRESSOR (SCROLL)	Power supply phases inverted. (three-phase compressor).	Check and reverse power phases.



All the components derived from the recycling of the unit should be managed according local legislation, and have to be classified and separated while dealt by authorized waste manager or be left in local waste facilities.

Refrigerant fluids, electronic boards, heat exchangers and the oil extracted from the refrigerant circuit, as well as the oil recipients used must be recycled as hazardous waste according the local normative through an authorized waste manager or be left in local waste facilities. The rest of the components considered as non-hazardous wastes must be recycled according to the corresponding norms.

At the end of its life, the equipment should be recycled in local waste facilities or by an authorized waste manager.

4. MAINTENANCE

4.3.1.- SAFETY DEVICES

ASTP COMPRESSOR PROTECTION:

This device protects the compressor against high discharge temperatures. When the temperature reaches critical values, ASTP protection causes the "Scrolls" to separate. The compressor stops pumping but the motor continues to run.

- Occasionally, when the compressor stops and starts, there is a metallic noise due to the compressor scrolls. This is normal.
- Connect high and low pressure gauges and check that the operating pressures are normal.
- Measure electrical consumption for the unit and check that it is close to that indicated on the specification plate.
- Check the electrical consumption of the compressor and the fans against that specified in the physical data sheets.
- In the case of a Heat Pump unit, make a cycle change on the Control Panel, checking that the 4-way valve makes the change correctly. Check the pressures in the new cycle.
- **Split and Multi-split: Low pressure switch and high pressure switch are reset automatically and if it operates 3 times in one day, they change to manual reset, through the control unit.**
- **With C60 control: Low pressure switch and high pressure switch are reset automatically and if it operates 3 times in one day, they change to manual reset, through the control unit.**

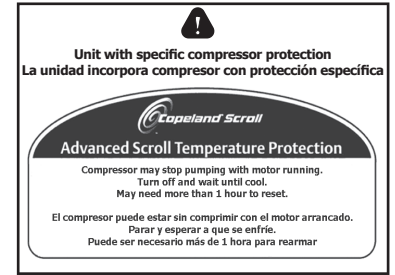



lennoxemeia.com

SALES OFFICES :

BELGIUM AND LUXEMBOURG

☎ + 32 3 633 3045

FRANCE

☎ +33 1 64 76 23 23

GERMANY

☎ +49 (0) 211 950 79 600

ITALY

☎ + 39 02 495 26 200

NETHERLANDS

☎ + 31 332 471 800

POLAND

☎ +48 22 58 48 610

PORTUGAL

☎ +351 229 066 050

RUSSIA

☎ +7 495 626 56 53

SPAIN

☎ +34 915 401 810

UKRAINE

☎ +380 44 461 87 79

UNITED KINGDOM AND IRELAND

☎ +44 1604 669 100

OTHER COUNTRIES :

LENNOX DISTRIBUTION

☎ +33 4 72 23 20 00

Due to Lennox's ongoing commitment to quality, the specifications, ratings and dimensions are subject to change without notice and without incurring liability. Improper installation, adjustment, alteration, service or maintenance can cause property damage or personal injury. Installation and service must be performed by a qualified installer and servicing agency

