

INDICE	
REGLETERO CONEXIONES ELECTRICAS TERMINAL STRIP BORNIER DE CONNEXION ELECTRIQUE KLEMMLEISTE AANSLUITSTRIP	HOJA 1/6
CIRCUITO POTENCIA POWER CIRCUIT CIRCUIT DE PUISSANCE STROMKREIS HOOFDSTROOMCIRCUIT	HOJA 2/6
CIRCUITO MANIOBRA CONTROL CIRCUIT CIRCUIT DE CONTROL STEUERKREIS REGELCIRCUIT	HOJA 3/6
CONEXION OPCIONALES OPTIONS CONNEXIONS OPCIONNELS OPTIONEN / ZUBEHÖR OPTIES	HOJA 4-5/6
LEYENDA REFERENCIAS REFERENCES LEGEND REFERENCE DE LEGENDE LEGENDE VERKLARING LEGENDA	HOJA 6/6



ESQUEMA ELECTRICO
WIRING DIAGRAM
SCHEMA ELECTRIQUE
SCHALTPLAN
ELECTRISCH SCHEMA

Elemento Opcional
Optional Element
Elément optionnel
Optionales bauteil
Optioneel element

A realizar por el instalador
To wire by the installer
A câbler par l'installateur
Verdrahtung durch den installateur
Installateurzijdig te bedraden

* RETIRAR PUENTE SI SE MONTA REA
 REMOVE LINK FOR REA OPERATION
 RETIRER LE POND S'IL Y A REA
 ENTFERNE DIE VERBINDUNG ZUM REA
 VERWIJDER LIK BIJ REA

⚠ ESTAS BORNAS SOLAMENTE SE INCLUYEN CON SU OPCIONAL
 THESE TERMINALS ARE ONLY INCLUDED WITH ITS OPTIONAL
 CES CONTACTS SONT INSTALLES SEULEMENT SI ON DEMANDE LEUR OPTIONEL
 DIESE ANSCHLUSSKLEMMEN SIND NUR MIT ZUBEHÖR VERFÜGBAR IHREM
 DEZE AANSLUITKLEMMEN ZIJN ALLEEN VOORZIE BIJ TOEPASSING VAN HUN OPTIONELE

VER MANUAL INSTALACION
 SEE INSTALLATION MANUAL (IOM)
 VOIR LE MANUEL D'INSTALLATION
 SIEHE INSTALLATIONSHANDBUCH (IOM)
 ZIE INSTALLATION MANUAL (IOM)

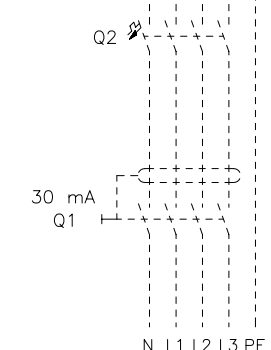
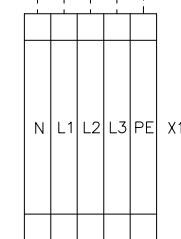
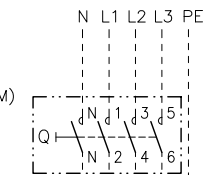
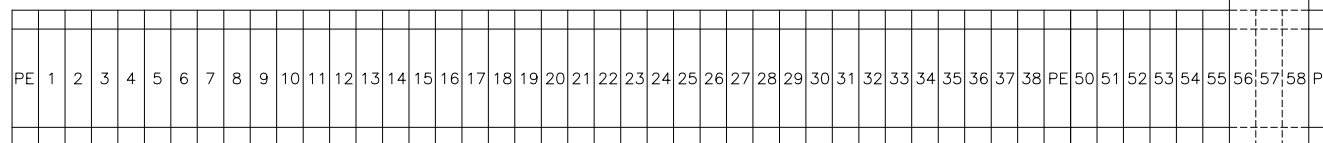

BORNAS DE CONEXION ELECTROVALVULA LINEA DE LIQUIDO EXTERNA
 EXTERNAL LIQUID LINE SOLENOID VALVE TERMINALS
 BORNIER DE CONNEXION DE L'ELECTROVANNS DE LIQUIDE
 ANSTEUERUNG FLÜSSIGKEITSMAGNETVENTIL
 KLEMMEN EXTERNE MAGNEETKLEP VLOEISTOFLEIDING

SC COMPRESOR (2 ETAPA)
 COMPRESSOR (2 STAGE)
 COMPRESSEUR (2 ETAPE)
 KOMPRESSOR (2 STUFE)
 COMPRESSOR (2 STAP)

SC COMPRESOR (1 ETAPA)
 COMPRESSOR (1 STAGE)
 COMPRESSEUR (1 ETAPE)
 KOMPRESSOR (1 STUFE)
 COMPRESSOR (1 STAP)

SEÑAL DE ALARMA
 ALARM SIGNAL
 SIGNALISATION D'ALARME
 ALARM MELDUNG
 ALARM SIGNAL

ALIMENTACION
 POWER SUPPLY
 ALIMENTATION ELECTRIQUE
 STROMZULEITUNG
 AANSLUITSPANNING
 3N ~ 400V 50Hz + PE

REA

Elemento Opcional
 Optional Element
 A Realizar por el Instalador
 To Wire by the Installer

3N~400V 50Hz + PE
N L1 L2 L3 PE

VER MANUAL INSTALACION
SEE INSTALLATION MANUAL (IOM)
VOIR LE MANUEL D'INSTALLATION
SIEHE INSTALLATIONSHANDBUCH (IOM)
ZIE INSTALLATION MANUAL (IOM)

Q1
30 mA

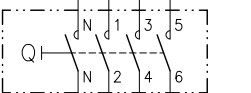
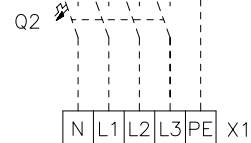

INTENSIDAD CURRENT INTESITÉ STROM STROOM	KSCK 112D FP1/FP2		KSCK 128D FP1/FP2		KSCK 152D FP1/FP2		
	Im(MCC)	Ia(LRA)	Im(MCC)	Ia(LRA)	Im(MCC)	Ia(LRA)	
400V 3~50Hz	CM1-2	20,7A	127A	20,7A	127A	25,6A	158A
	CM3	29,8A	189A	37,5A	225A	48A	272A
	CFM1-2	8,3A	29A	8,3A	29A	8,3A	29A

FUSIBLES FUSES FUSIBLES SICHERUNGEN ZEKERINGEN	KSCK 112D-128D-152D FP1/FP2			
	112D	128D	152D	
400V 3~50Hz	F1-2(CM1-2)	6x25A	6x25A	6x32A
	F3(CM3)	3x40A	3x50A	3x63A
	F4-5(CFM1-2)	6x10A	6x10A	6x10A

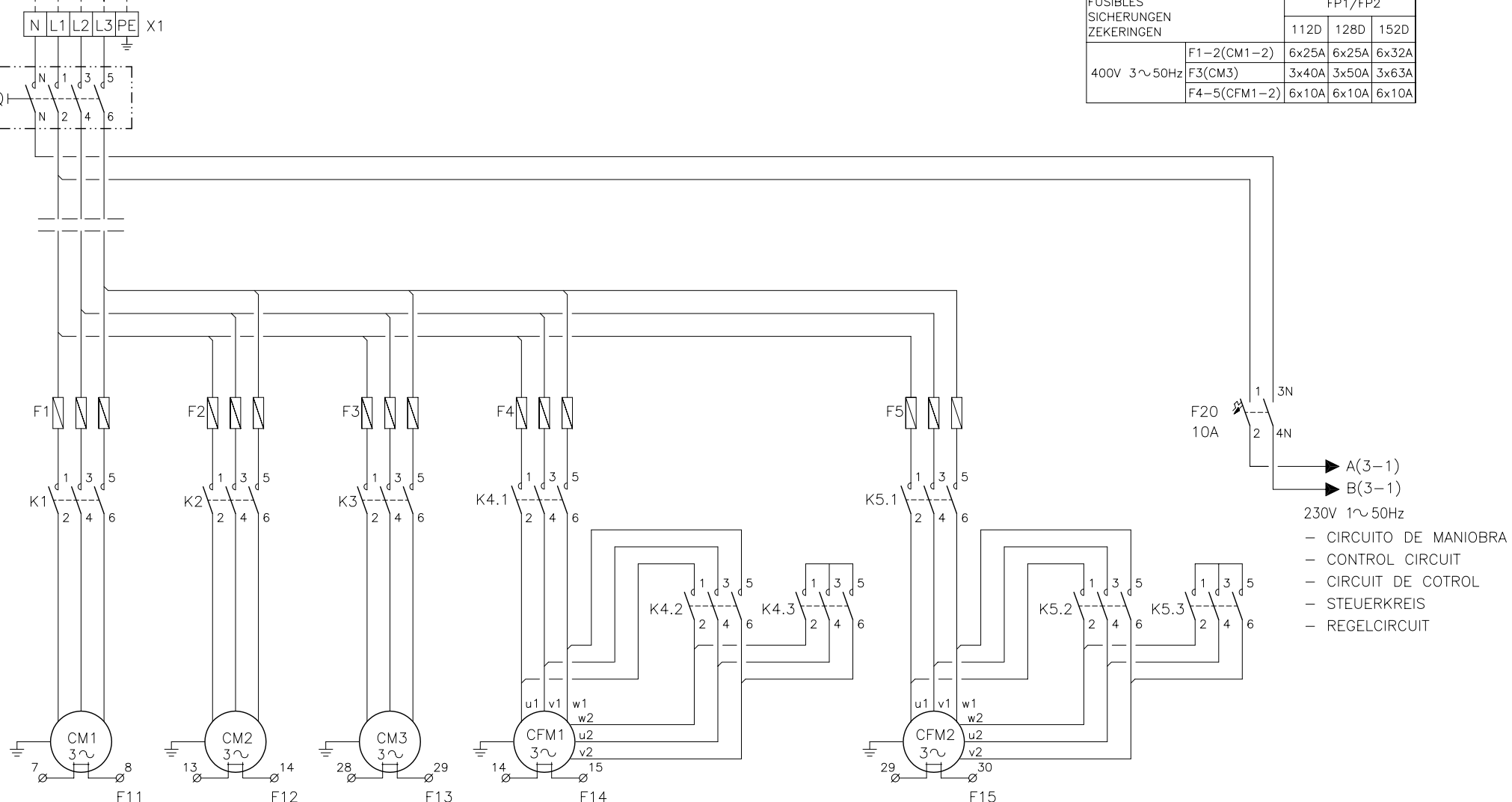

230V 1~50Hz
- CIRCUITO DE MANIOBRA
- CONTROL CIRCUIT
- CIRCUIT DE COTROL
- STEUERKREIS
- REGELCIRCUIT

Elemento Opcional
Optional Element
A Realizar por el Instalador
To Wire by the Installer

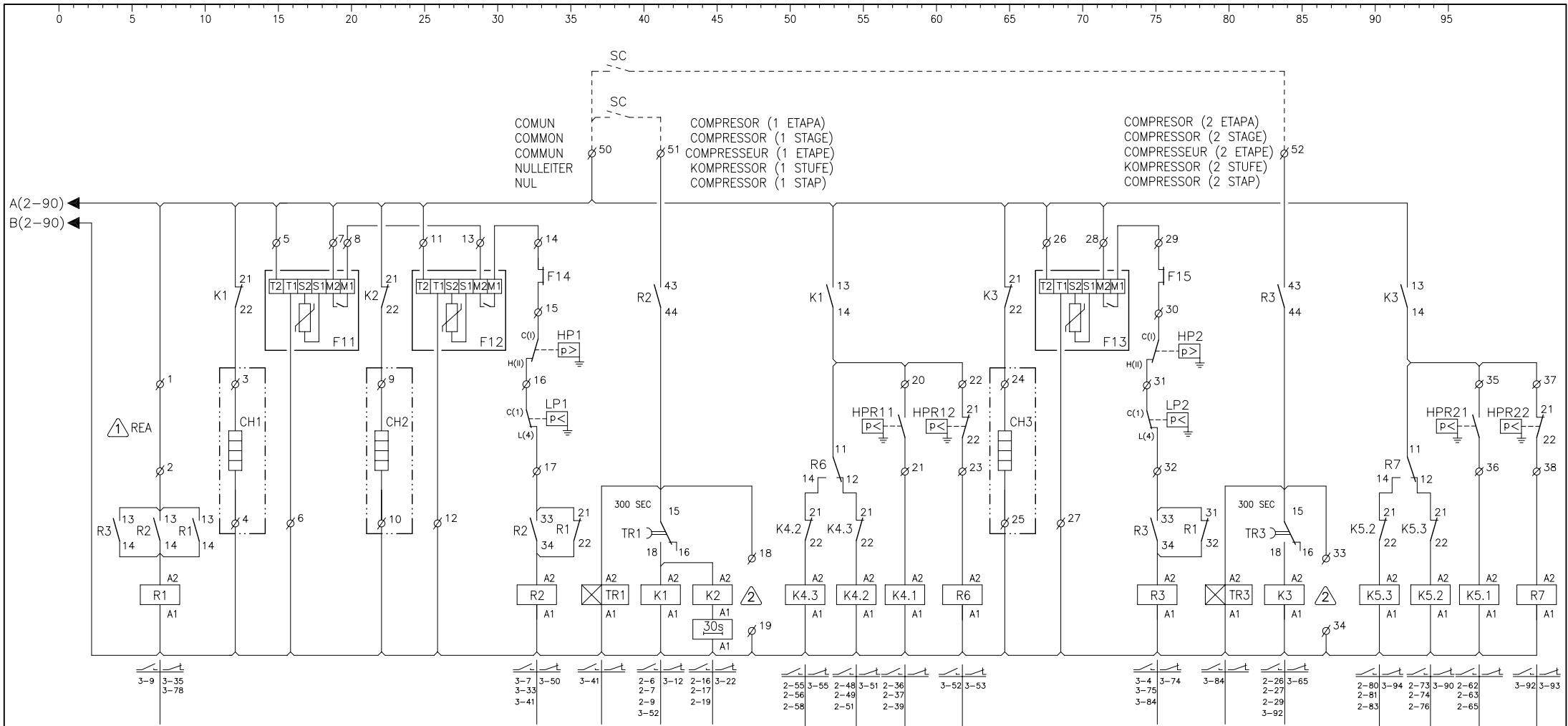

1 REARME ALARMA POR DESCONEXION ALIMENTACION/ABERTURA PUENTE REA
 ALARM RESET THROUGH SWITCH OFF POWER/OPENING JUMPER REA
 REARMEMENT DE DEFAULT PAR COUPEURE DE COURRANT ALIMENTATION/OUVERTURE DU POND REA
 ALARMRESET DURCH ABSCHALTEN DES STROMS/OFFNEN DES JUMPERNS REA
 ALARM RESET DOOR UITSCHAKELN POWER/OPENING JUMPER REA

2 BORNAS DE CONEXION ELECTROVALVULA LINEA DE LIQUIDO EXTERNA
 EXTERNAL LIQUID LINE SOLENOID VALVE TERMINALS
 BORNIER DE CONNEXION DE L'ELECTROVANNS DE LIQUIDE
 ANSTEUERUNG FLÜSSIGKEITSMAGNETVENTIL
 KLEMMEN EXTERNE MAGNEETKLEP VLOEISTOFLEIDING

53 COMUN/COMMON/COMMUN/NULLEITER/NUL
 21 SEÑAL DE ALARMA (1 ETAPA)
 22 ALARM SIGNAL (1 STAGE)
 22 SIGNALISATION D'ALARME (1 ETAPE)
 22 ALARM MELDUNG (1 STUFE)
 22 ALARM SIGNAL (1 STAP)
 21 SEÑAL DE ALARMA (2 ETAPA)
 22 ALARM SIGNAL (2 STAGE)
 22 SIGNALISATION D'ALARME (2 ETAPE)
 22 ALARM MELDUNG (2 STUFE)
 22 ALARM SIGNAL (2 STAP)

TARADO DE HPR(11-21): CORTE 14BAR REARME 17BAR. TARADO DE HPR(12-22): CORTE 26BAR REARME 24BAR
 HPR(11-21) SETPOINT: OFF 14BAR RESET 17BAR. HPR(12-22) SETPOINT: OFF 26BAR RESET 24BAR
 REGLAGE HPR(11-21): COUPEURE 14BAR REARMEMENT 17BAR. REGLAGE HPR(12-22): COUPEURE 26BAR REARMEMENT 24BAR
 HD-PRESSOSTAT(11-21): AUS BEI 14BAR RESET BEI 17BAR. HD-PRESSOSTAT(12-22): AUS BEI 26BAR RESET BEI 24BAR
 HD SETPOINT(11-21): OFF 14BAR RESET 17BAR. HD SETPOINT(12-22): OFF 26BAR RESET 24BAR

Elemento Opcional
 Optional Element
 A Realizar por el Instalador
 To Wire by the Installer

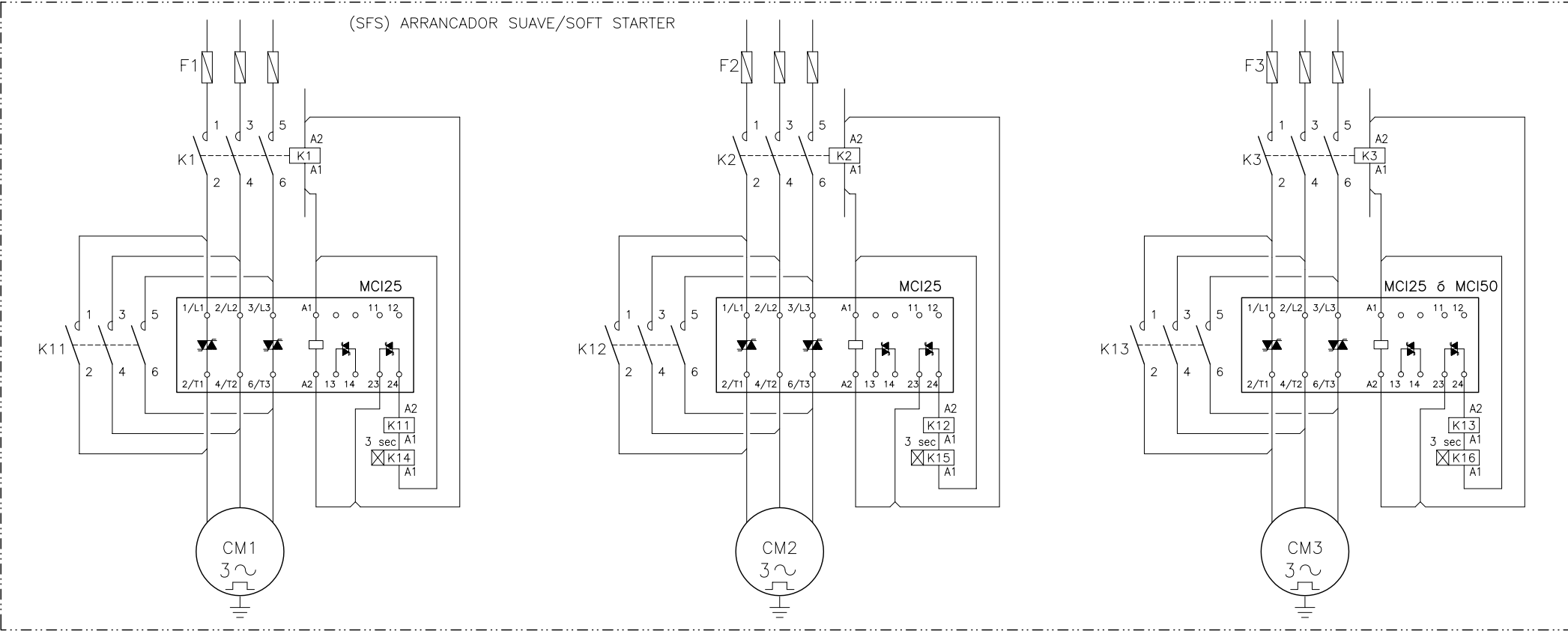
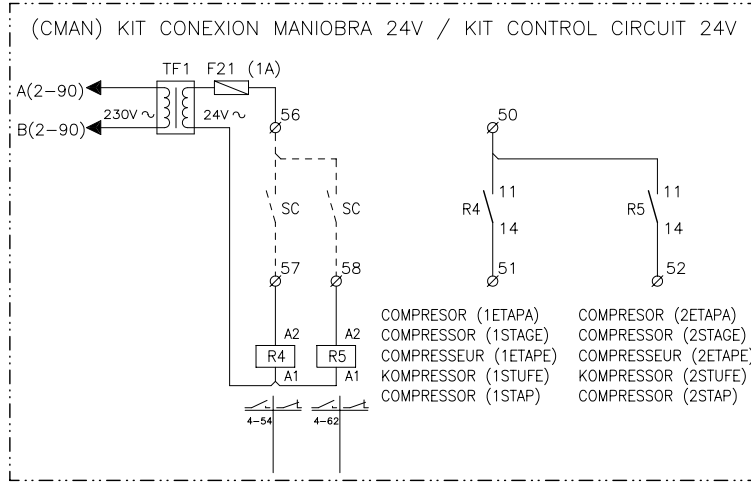
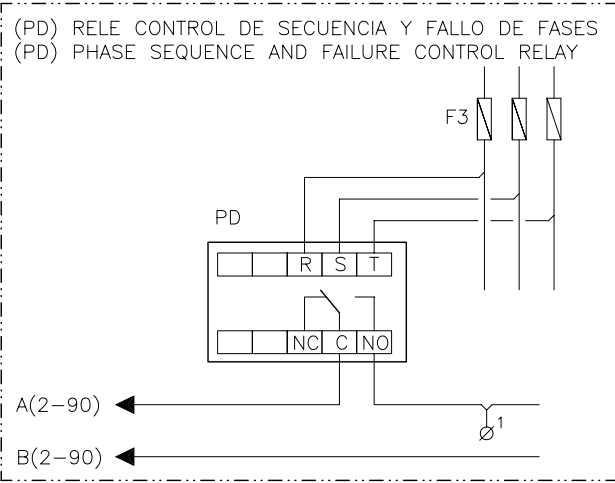

Elemento Opcional
Optional Element
A Realizar por el Instalador
To Wire by the Installer

(FSC) CONTROL DE CONDENSACION/FAN SPEED CONTROL

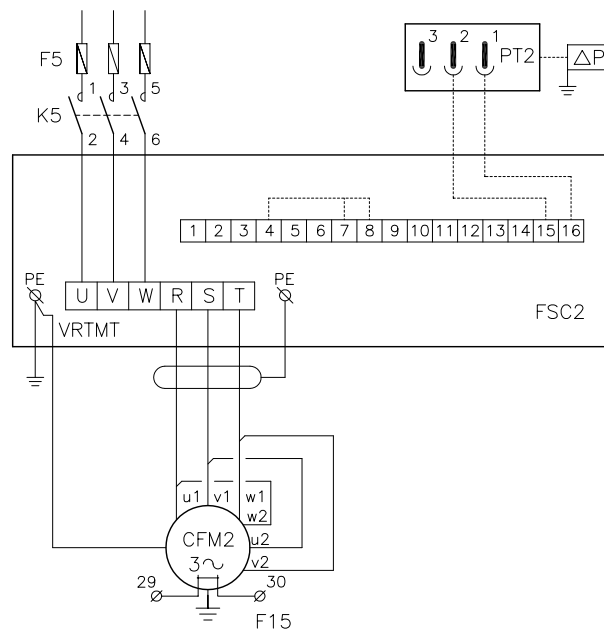
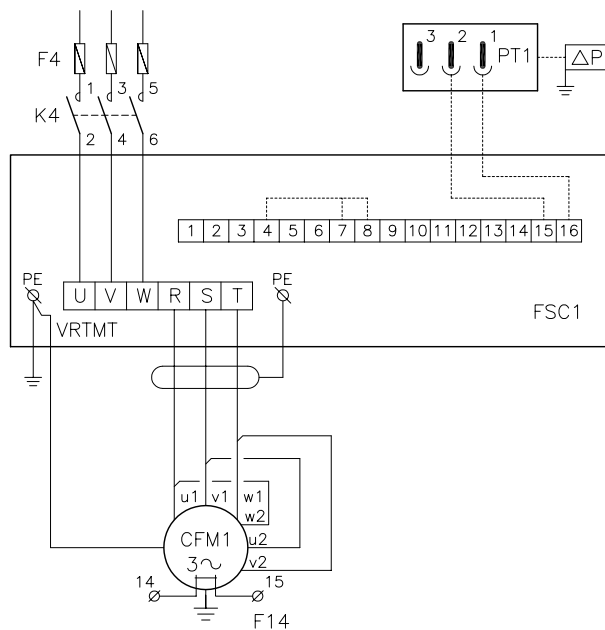

Elemento Opcional
 Optional Element
 A Realizar por el Instalador
 To Wire by the Installer

	LEYENDA	LEGEND	REFERENCE	LEGENDE	LEGENDA
Cd	Condensador	Condenser	Condenseur	Kondensator	Condensator
CH	Resistencia de carter	Crankcase heater	Résistance de carter	Kurbelwannenheizung	Carterverwarming
CFM	Motor ventilador exterior	Compressor fan motor	Moteur ventilateur extérieur	Kondensatorlüftermotor	Condensator ventilador motor
CM	Motor compresor	Compressor motor	Compresseur	Kompressor	Compressor motor
CMAN	Kit conexión maniobra 24V	Kit control circuit 24V	Kit circuit de control en 24V	Externe freigabe kompressor 24V	24V stuurstroam kit
FSC1-2	Control de condensación	Fan speed control	Variateur de vitesse du ventilateur	Kondensationsdruckregelung	Ventilator snelheidsregelaar
F1-5	Fusibles	Fuses	Fusibles	Sicherungen	Zekeringen
F11-13	Módulo protección compresor	Compresor protector module	Module protection du compresseur	Therm. kompressorrelais	Compressor beveiligings module
F14-15	Protección térmica	Thermal protection	Protection thermique	Therm. kompressorrelais	Compressor thermische beveiliging
F20	Magnetotérmico	Circuitbraker	Magneto thermique	Motorschutzschalter	Thermisch relais
F21	Fusible del TF1	TF1 fuse	Fusible TF1	TF1 schütz	TF1 zekering
HP1-2	Presostato de alta	High pressure pressostat	Pressostat HP	Hochdruckpressostat	Hoge druk pressostaat
HPR	Control condensación TODO/NADA	Winter control ON/OFF	C. pression condensation ON/OFF	K. druckregelung ON/OFF	Winter regeling AAN/UIT
Ia(LRA)	Intensidad de arranque	Starting current	Intensité de démarrage	Anlaufstrom	Opstart stroom
Im(MCC)	Intensidad máxima	Maximum current	Intensité maximum	Maximale stromstärke	Maximaal stroom
K	Contactar	Contactar	Contacteur	schütz	Relais
LP1-2	Presostato baja	Low pressure pressostat	Pressostat BP	Niederdruckpressostat	Lagedruk beveiling
PD	Relé control de secuencia-fallo de fases	Phase sequence and failure control relay	Détecteur de phase	Phasenfolgenüberwachung+Störemel	Fasevolgorde-foutcontrole relais
PT1-2	Transductor de presión	Pressure transducer	Transducteur de pression	Druck messwandler	Drukopnemer
Q	Interruptor general	Main switch	Interrupteur général	Hauptschalter	Hoofdschakelaar
Q1	Interruptor diferencial	Ground safety switch	Interrupteur différentiel	Schalter	Aardekschakelaar
Q2	Interruptor magnetotérmico	Circuit breaker	Interrupteur magneto thermique	Motorschutzschalter	Magneetschakelaar
REA	Rearme alarma	Alarm reset	Réarmement d'alarmes	Alarmreset	Alarm reset
R1	Relé rearme	Reset relay	Relais de réarmement	Resetrelais	Reset relais
R2-3	Relé señal de alarma	Alarm signal relay	Relais défaut à distance	Störmelderelais	Storingrelais
R4-7	Relé auxiliar	Auxiliary relay	Relais auxiliaire	Hilfsrelais	Aux. relais
SC	Conexión arranque	Start connection	Contact de demarrage	Freigabekontakt kompressor	Startcommando
SFS	Arrancador suave	Soft starter	Démarrreur progressif	Softstarter/Sanftanlauf	Soft starter
TF1	Transformador	Transformer	Transformateur	Transformator	Transformator
TR1-3	Temporizador	Timer	Temporisation	Schaltuhr	Timer
	CODIGO DE COLORES	COLOUR CODE	CODE COLEUR	FARBKENNUNG	KLEURCODE
bk	negro	black	noir	schwarz	zwart
br	marrón	brown	brun	braun	bruin
rd	rojo	red	rouge	rot	rood
or	naranja	orange	orange	orange	oranje
yl	amarillo	yellow	jaune	gelb	geel
gn	verde	green	vert	grün	groen
bl	azul	blue	bleu	blau	blauw
vi	violeta	violet	violet	viollet	violet
gr	gris	gray	gris	grau	grijs
wh	blanco	white	blanc	weiss	wit