

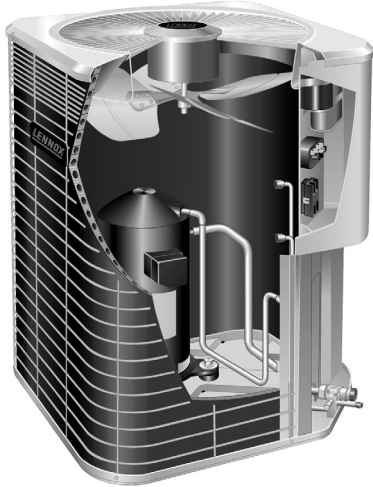

© 2000 Lennox Industries Inc.  
Dallas, Texas, USA



# INSTALLATION INSTRUCTIONS

## HP40 Heat Pump Units

HEAT PUMP UNITS  
1-1/2 through 5 ton  
504,538M  
11/2002  
Supersedes 5/2002

Technical  
Publications  
Litho U.S.A.

### Table of Contents

HP40 Heat Pump Unit .....	1
Shipping & Packing List .....	1
General Information .....	1
Unit Dimensions .....	2
Setting the Unit .....	3
Electrical .....	4
Plumbing .....	5
Refrigerant Metering Device .....	5
Manifold Gauge Set .....	7
Liquid & Vapor Line Service Valves .....	7
Leak Testing .....	8
System Evacuation .....	9
Start-Up .....	9
Charging Considerations .....	10
System Operation .....	12
Defrost System .....	12
Maintenance .....	13

**RETAIN THESE INSTRUCTIONS  
FOR FUTURE REFERENCE**

### HP40 Heat Pump Unit

HP40 heat pumps use R407C which is an ozone friendly HFC refrigerant. This unit must be installed with a matching indoor coil and line set as outlined in the Lennox Engineering Handbook. HP40 heat pumps are designed for use in expansion valve systems only. They are not designed to be used in RFC systems. An expansion valve and filter drier approved for use with R407C have been shipped with the unit. These components must be installed prior to unit operation.

### IMPORTANT

**This unit must be matched with an indoor coil as specified in Lennox' Engineering Handbook. Coils previously charged with R22 must be flushed.**

### WARNING

**This equipment must only be installed and serviced by properly qualified personnel. Equipment contains dangerous voltages and moving parts. Always switch off power supply before opening any access panel. Electrical control panel doors and fan access door must be locked to prevent unauthorized access at beginning of instruction.**

### WARNING

**Refrigerant can be harmful if it is inhaled. Refrigerant must be used and recovered responsibly. Failure to follow this warning may result in personal injury or death.**

### Shipping & Packing List

- 1 - Assembled HP40 heat pump unit
- 1 - Bag assembly:
  - 1 - Sight glass
  - 1 - Coupling reducer, 5/16 x 3/8 inch (024)

Check unit for shipping damage. If any damage is found, contact the last carrier immediately.

### General Information

These instructions are intended as a general guide and do not supersede national or local codes in any way. Consult authorities having jurisdiction before installation.

The HP40 unit is "CE marked" in accordance with the requirements of the latest European Directives for Electrical and Machinery Safety and Electromagnetic Compatibility. In addition, HP40 units have type Approval Certification with the Gas Appliance Directive.

### IMPORTANT

**International Legislation bans the intentional venting of refrigerant (CFCs and HCFCs). Approved methods of recovery, recycling or reclaiming must be followed. Fines and/or incarceration may be levied for noncompliance.**



**Unit Dimensions - mm**

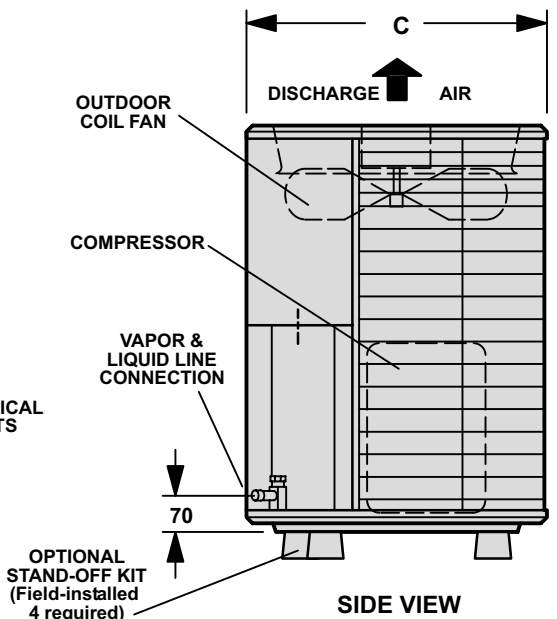
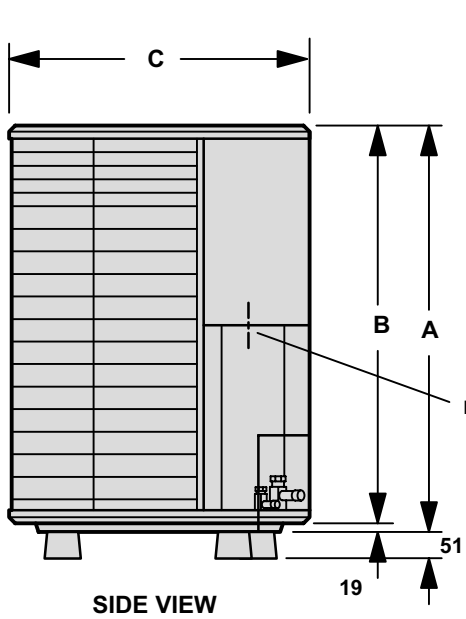
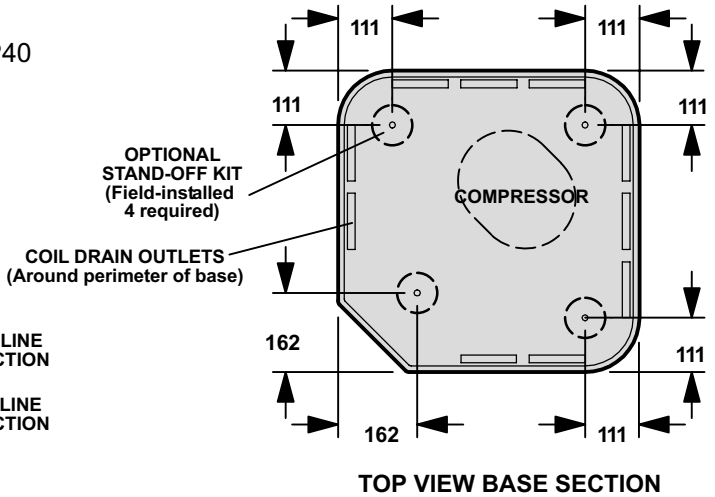
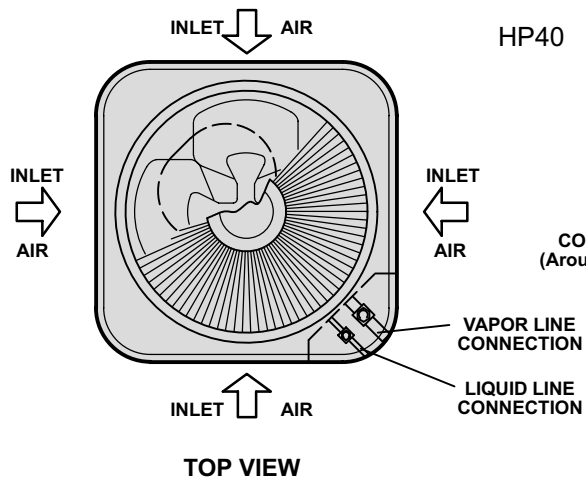

Model Number		A	B	C
HP40-018		635	616	616
HP40-024	mm			
HP40-036		838	819	616
HP40-048	mm			
HP40-060		946	927	718
	mm			

## Setting the Unit

Heat pump units operate under a wide range of weather conditions; therefore, several factors must be considered when positioning the outdoor unit. The unit must be positioned to give adequate clearances for sufficient air-flow and servicing. Maintain a minimum clearance of 610 mm between multiple units. Refer to figure 1 for installation clearances.

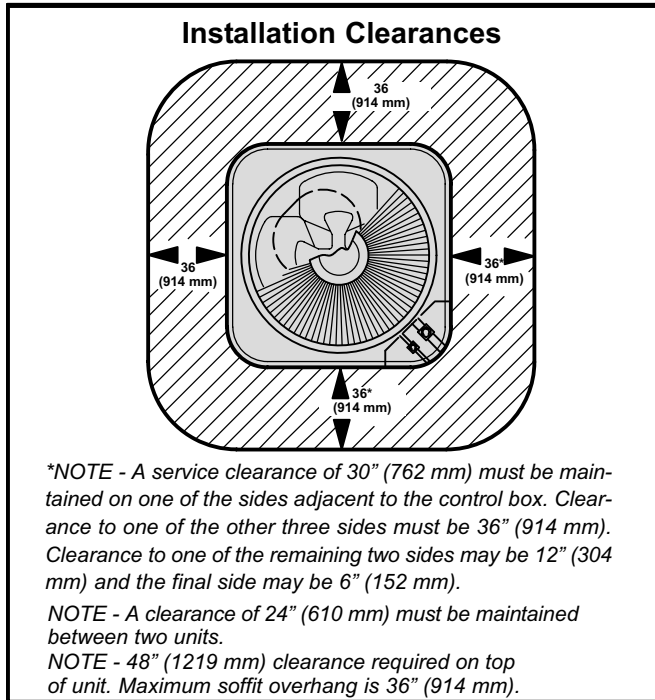

**FIGURE 1**

- 1 - Place a sound-absorbing material, such as Isomode, under the unit if it will be installed in a location or position that will transmit sound or vibration to the living area or adjacent buildings.
- 2 - Install the unit high enough above the ground or roof to allow adequate drainage of defrost water and prevent ice buildup.
- 3 - In areas that receive heavy snow, do not locate the unit where drifting will occur. Ensure that the unit base is elevated above the depth of average snows.
 

*NOTE - Elevate the unit by constructing a frame using suitable materials. If a support frame is constructed, it must not block drain holes in the base of the unit.*
- 4 - When you install the unit in areas where low ambient temperatures exist, locate the unit so winter prevailing winds do not blow directly into outdoor coil.
- 5 - Locate unit away from overhanging roof lines which would allow water or ice to drop on, or in front of, coil or into unit.

## Slab Mounting (See figure 2)

When the unit is installed at grade level, the top of the slab should be high enough above the grade so that water from higher ground will not collect around unit. Slab should have a slope tolerance away from the building of 2 degrees or 51 mm per 1.5 m. This will prevent ice from building up under the unit during a defrost cycle. Refer to roof mounting section for barrier construction if unit must face prevailing winter winds.

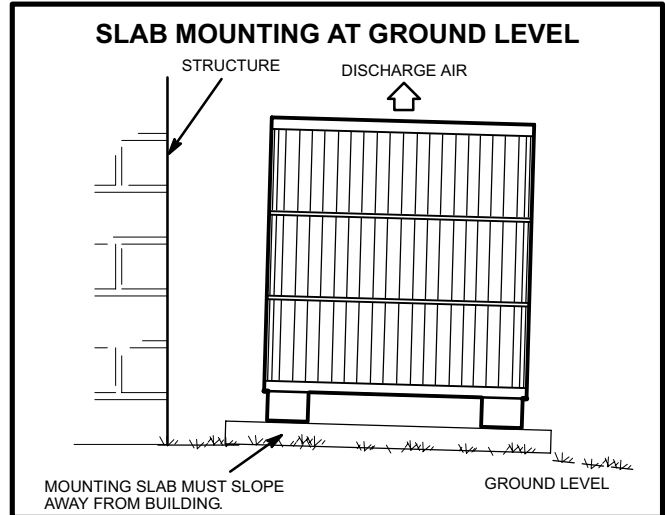
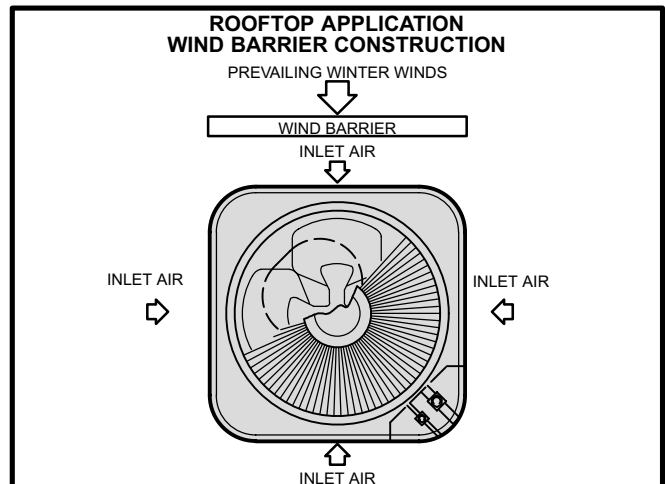

**FIGURE 2**

## Roof Mounting (See figure 3)

If you are unable to mount the unit coil away from prevailing winter winds, construct a wind barrier. Size the barrier at least the same height and width as the outdoor unit. Mount the barrier 610 mm from the sides of the unit in the direction of prevailing winds.

Install the unit at a minimum of 152 mm above the roof surface to keep ice from building up around the unit. Locate the unit above a load bearing wall or area of the roof that can adequately support the unit. Consult local codes for rooftop applications.



**FIGURE 3**

## Electrical

Wiring must conform with current local codes. An application diagram is included in this instruction and in the indoor unit instructions.

Refer to the unit rating plate, located on the control box cover, for minimum circuit ampacity and maximum fuse size.

- 1 - Provide line voltage power supply to the unit from a properly sized disconnect switch. The disconnect switch should be located so that it is easily accessible and within sight of the unit.
- 2 - Route the power and ground wires from the disconnect switch to the unit. The electrical openings are provided under the control box cover. See the unit di-

mensions illustration on page 2.

- 3 - Remove the control box cover and connect the power wiring to the contactor. Connect ground wire to ground lug.
- 4 - Install the room thermostat (ordered separately) in the conditioned area. Place the thermostat where it will not be affected by sunlight, drafts, or vibration. Do not install the thermostat on an outside wall. The most desirable position for the thermostat is near the center of the conditioned area and approximately 1.5 m from the floor.
- 5 - Route 24VAC control wires from the thermostat to the indoor unit and from the indoor unit to the defrost control terminals in the outdoor unit as shown in figure 4.

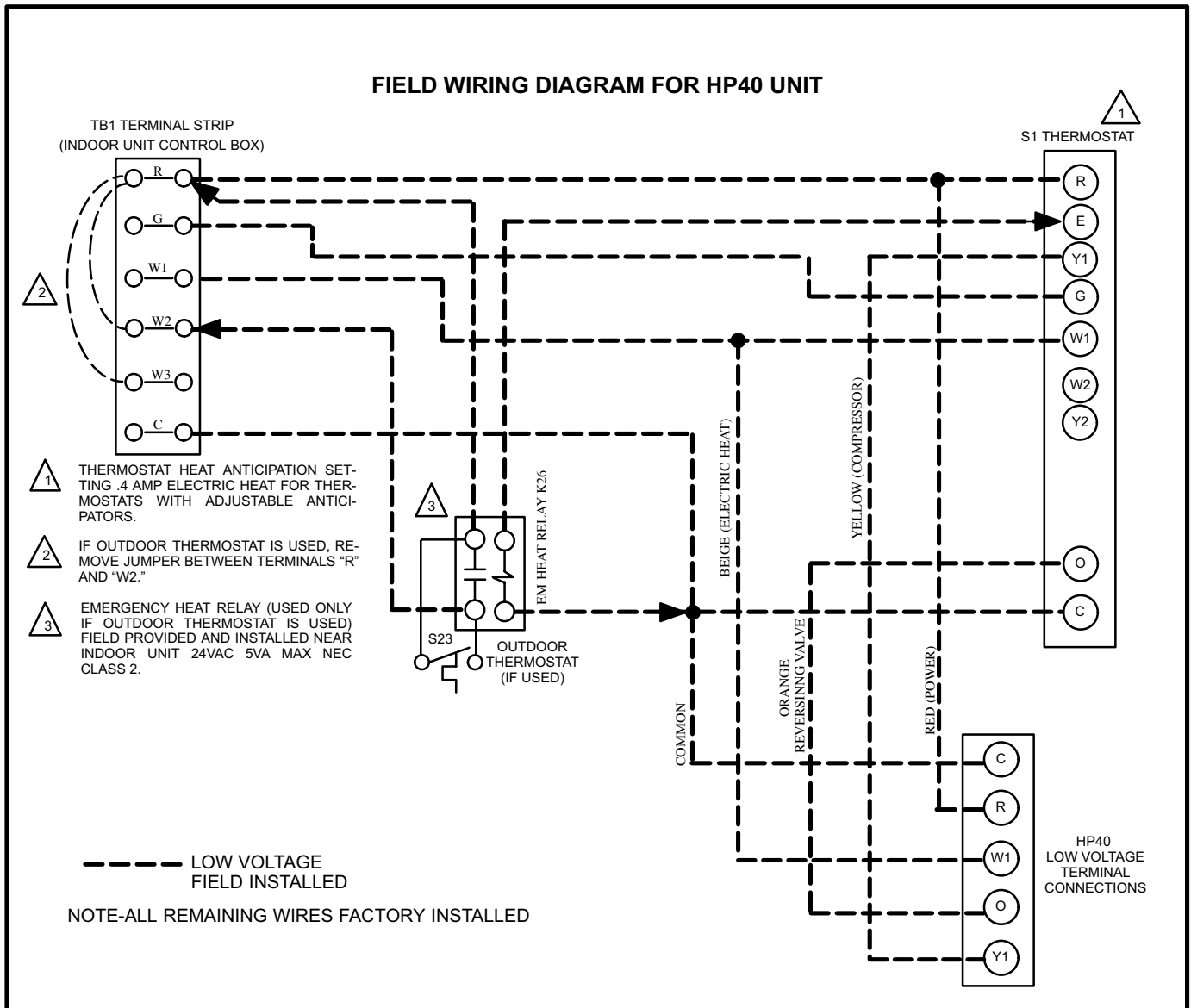

FIGURE 4

## Plumbing

Field refrigerant piping consists of liquid and vapor lines from the heat pump (sweat connections) to the indoor evaporator coil. Use Lennox L15 (sweat connection) series line sets as shown in table 1 or use field-fabricated refrigerant lines. Refer to Refrigerant Piping Guide (Corp. 9351-L9) for proper size, type, and application of field-fabricated lines.

If refrigerant tubes are routed through a wall, seal and isolate the opening so vibration is not transmitted to the building.

*NOTE - Line length should be no greater than 15.2 m. Select line set diameters from table 1 to ensure that the oil returns to the compressor.*

**TABLE 1  
REFRIGERANT LINE SET KITS**

HP40 UNIT	LIQUID LINE	SUCTION LINE	L15 LINE SETS
HP40-024	8 mm*	16 mm	L15 - 21 4.6 m - 15 m
HP40-036	10 mm	19 mm	L15 - 41 4.6 m - 15 m
HP40-048	10 mm	22 mm	L15 - 65 4.6 m - 15 m
HP40-060	10 mm	29 mm	FIELD FABRICATED

\*Use the coupling reducer that is supplied in the bag assembly.

### Sweat Connection Procedure

- 1 - The ends of refrigerant lines must be cut square, free from nicks or dents and deburred. The pipe must remain round. Do not pinch the end of the line.
- 2 - Wrap a wet cloth around the liquid line valve body and copper tube stub to protect them from heat damage during brazing. Wrap another wet cloth underneath the liquid valve to protect the base paint.
- 3 - Quench the joints with a wet cloth to prevent possible heat damage to the valve core and opening port.

## Refrigerant Metering Device

HP40 units are applicable to thermal expansion valve systems only. An expansion valve appropriate for use with R407C refrigerant is shipped with the outdoor unit.

## ⚠ IMPORTANT

**Failure to remove an existing refrigerant flow control orifice when installing an expansion valve on the indoor coil will result in improper operation and damage to the system.**

## Flushing Existing Line Set and Indoor Coil

## ⚠ IMPORTANT

**If this unit is being matched with an approved line set or indoor coil which was previously charged with R22 refrigerant, or if it is being matched with a coil which was manufactured before January of 1999, the coil and line set must be flushed prior to installation. Take care to empty all existing traps. Polyol ester (POE) oils are used in Lennox units charged with R407C refrigerant. Polyol ester oils are not compatible with mineral oils. Residual mineral oil can act as an insulator, preventing proper heat transfer. It can also clog the thermal expansion valve, reducing system performance and capacity. Failure to properly flush the system per the instructions below will void the warranty.**

## ⚠ CAUTION

**This procedure should not be performed on systems which contain contaminants (Example: compressor burn out).**

### Required Equipment

You will need the following equipment in order to flush the existing line set and indoor coil: two clean R22 recovery bottles, an oilless recovery machine with a pump down feature, and two sets of gauges (one or use with R22 and one for use with the R407C).

### Flushing Procedure

- 1 - Remove existing R22 refrigerant using the appropriate procedure below.

*If the existing outdoor unit is not equipped with shut-off valves, or if the unit is not operational AND you plan to use the existing R22 refrigerant to flush the system -- Disconnect all power to the existing outdoor unit. Connect the existing unit, a **clean** recovery cylinder and the recovery machine according to the instructions provided with the recovery machine. Remove all R22 refrigerant from the existing system. Refer to gauges after shutdown to confirm that the entire system is completely void of refrigerant. Disconnect the liquid and vapor lines from the existing outdoor unit.*

*If the existing outdoor unit is equipped with manual shut-off valves AND you plan to use NEW R22 refrigerant to flush the system -- Start the existing R22 system in the cooling mode and close the liquid line valve. Pump all of the existing R22 refrigerant back into the outdoor unit. (It may be necessary to bypass*

the low pressure switches to ensure complete refrigerant evacuation.) When low side system pressures reach 0 psig, close the suction line valve. Disconnect all power to the existing outdoor unit. Refer to gauges after shutdown to confirm that the valves are not allowing refrigerant to flow back into the low side of the system. Disconnect the liquid and vapor lines from the existing outdoor unit.

- 2 - Remove the existing outdoor unit. Set the new R407C unit and follow the brazing connection procedure to make line set connections. **DO NOT install provided R407C check/expansion valve at this time.**

Make low voltage and line voltage connections to the new outdoor unit. **DO NOT turn on power to the unit or open the outdoor unit service valves at this time.**

- 3 - Remove the existing refrigerant flow control orifice or thermal expansion/check valve before continuing with flushing procedures. The existing devices are not approved for use with R407C refrigerant and may prevent proper flushing. Use a field-provided fitting to reconnect the lines.
- 4 - Remove the pressure tap valve cores from the HP32 unit's service valves. Connect an R22 cylinder with clean refrigerant to the suction service valve. Connect the R22 gauge set to the liquid line valve and connect a recovery machine with an empty recovery tank to the gauge set.

## ⚠ IMPORTANT

**The line set and indoor coil must be flushed with at least the same amount of clean refrigerant that previously charged the system. Check the charge in the flushing cylinder before proceeding.**

- 5 - Set the recovery machine for liquid recovery and start the recovery machine. Open the gauge set valves to allow the recovery machine to pull a vacuum on the existing system line set and indoor coil.
- 6 - Invert the cylinder of clean R22 and open its valve to allow liquid refrigerant to flow into the system through the suction line valve. Allow the refrigerant to pass from the cylinder, through the line set and the indoor coil before entering the recovery machine.
- 7 - After all of the liquid refrigerant has been recovered, switch the recovery machine to vapor recovery so that all of the R22 vapor is recovered. All the recovery machine to pull a vacuum on the system.

*NOTE - A single system flush should remove all of the mineral oil from the existing refrigerant lines and indoor coil. A second flushing may be done (using clean refrigerant) if insufficient amounts of mineral oil were removed during the first flush. **Each time the system is flushed, you must allow the recovery machine to pull a vacuum on the system at the end of the procedure.***

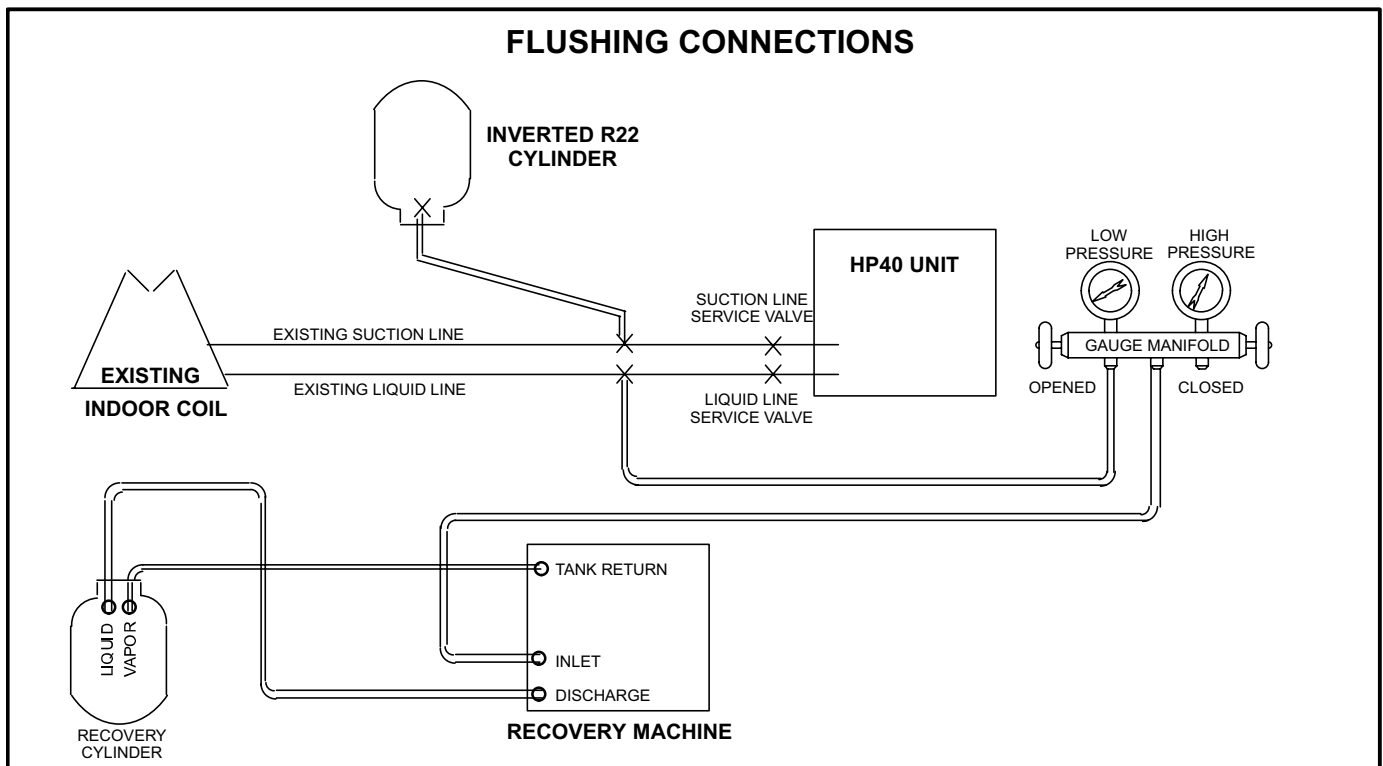
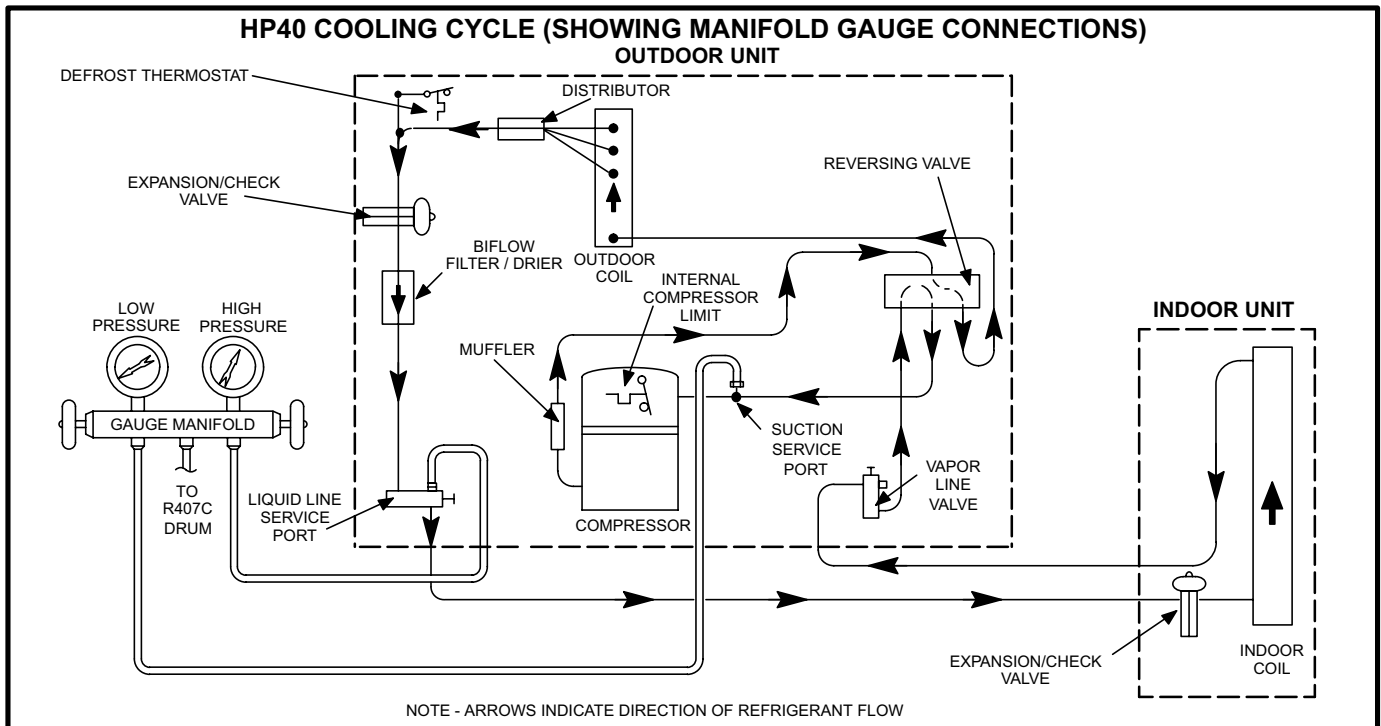

FIGURE 5



**FIGURE 6**

- 8 - Close the valve on the inverted R22 drum and the gauge set valves. Pump the remaining refrigerant out of the recovery machine and turn the machine off.
- 9 - Use nitrogen to break the vacuum on the refrigerant lines and indoor coil before removing the recovery machine, gauges and R22 refrigerant drum. Reinstall pressure tap valve cores into HP32 service valves.
- 10 - Install the provided check/expansion valve (approved for use with R407C refrigerant) in the liquid line at the indoor coil.

### Manifold Gauge Set

Manifold gauge sets used with systems charged with R407C refrigerant must be able to accommodate higher system operating pressures. The gauges should be rated for pressures of 0-800 psi on the high side and a low side of 30" vacuum to 250 psi with dampened speed of 500 psi. Gauge hoses must be rated for use at up to 800 psi of pressure with a 4000 psi burst rating.

### Liquid & Vapor Line Service Valves

Access the liquid line and vapor line service valves (figures 7 and 8) and the gauge ports from inside the unit, behind access panel. The service ports are used for leak testing, evacuating, charging, and checking the charge.

The valve is equipped with a service port, and a Schrader valve is factory installed. A service port cap is supplied to protect the Schrader valve from contamination and to serve as the primary leak seal.

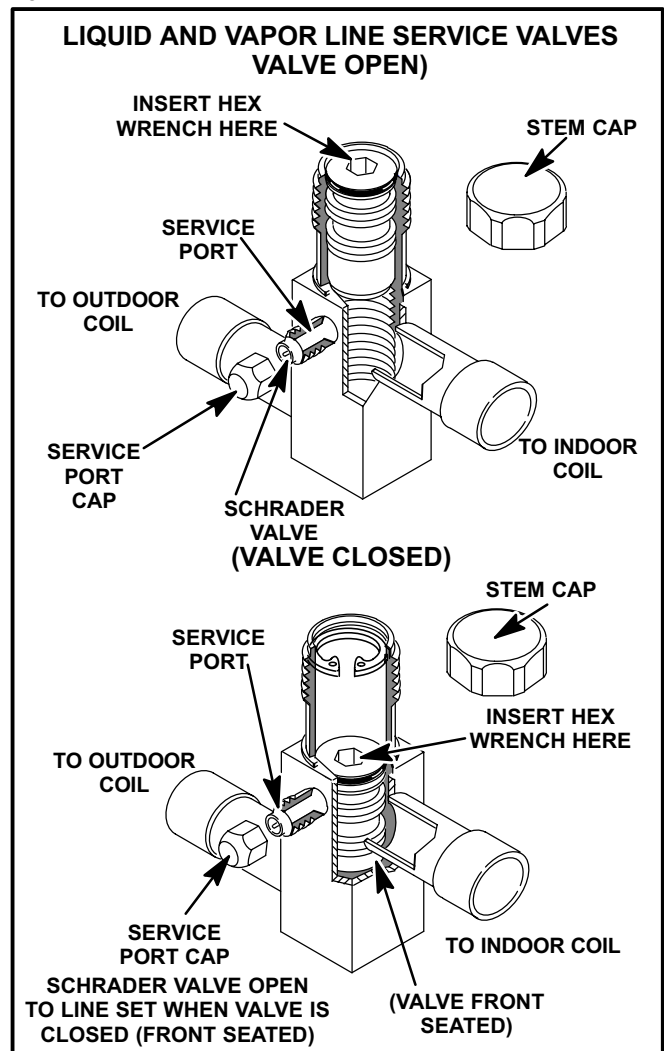

**FIGURE 7**

## ⚠ IMPORTANT

Service valves are closed to the heat pump unit and open to line set connections. Do not open until refrigerant lines have been leak tested and evacuated. All precautions should be exercised in keeping the system free from dirt, moisture and air.

### Accessing the Schrader Port:

- 1 - Remove service port cap with an adjustable wrench.
- 2 - Connect gauge to the service port.
- 3 - When testing is completed, replace the service port cap. Tighten finger tight, then tighten an additional 1/6 turn.

### To Open Liquid or Vapor Line Service Valve:

- 1 - Remove the stem cap with an adjustable wrench.
- 2 - Use a service wrench with a hex-head extension to back the stem out counterclockwise as far as possible.

## ⚠ WARNING

Do not attempt to backseat this valve. Attempts to backseat this valve will cause the snap ring to explode from the valve body under pressure of the refrigerant. Personal injury and unit damage will result.

- 3 - Replace the stem cap. Tighten finger tight, then tighten an additional 1/6 turn.

### To Close Liquid or Vapor Line Service Valve:

- 1 - Remove the stem cap with an adjustable wrench.
- 2 - Use a service wrench with a hex-head extension to turn the stem clockwise to seat the valve. Tighten firmly.
- 3 - Replace the stem cap. Tighten finger tight, then tighten an additional 1/6 turn.

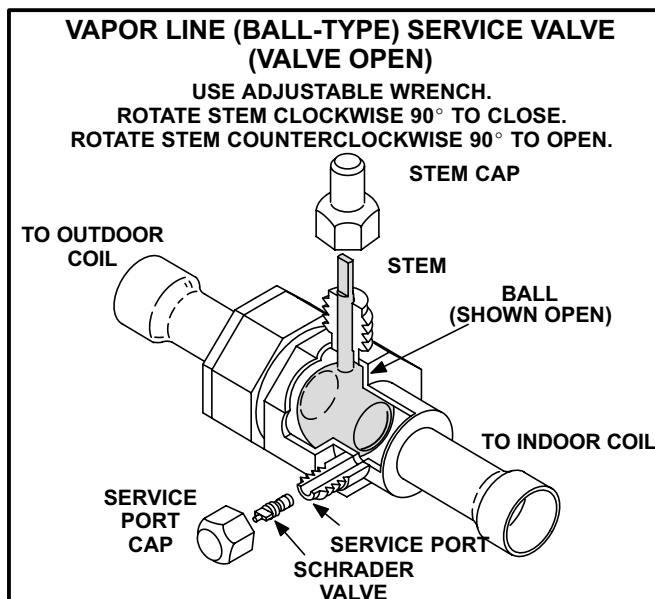

FIGURE 8

## Vapor Line (Ball-Type) Service Valve – 5-Ton Units

A ball-type full-service valve is used on five-ton units. These vapor line service valves function the same way, the differences are in construction. Valves are not rebuildable. If a valve has failed, it must be replaced. A ball valve is illustrated in figure 8.

The ball valve is equipped with a service port and a factory-installed Schrader valve. A service port cap is supplied to protect the Schrader valve from contamination and to assure a leak-free seal.

## Leak Testing

After the line set has been connected to the indoor and outdoor units, check all connections for leaks.

## ⚠ IMPORTANT

The leak detector must be capable of sensing HFC refrigerant.

## ⚠ WARNING

Never use oxygen to pressurize refrigeration or air conditioning system. Oxygen will explode on contact with oil and could cause personal injury. When using high pressure gas such as nitrogen for this purpose, be sure to use a regulator that can control the pressure down to a range of 6.9 to 13.8 kPa.

### Using an Electronic Leak Detector

- 1 - Connect a cylinder of nitrogen with a pressure regulating valve to center port of manifold gauge set.
- 2 - Connect the high pressure hose of the manifold gauge set to the service port of the vapor valve. (Normally, the high pressure hose is connected to the liquid line port, however, connecting it to the vapor port better protects the manifold gauge set from high pressure damage.)
- 3 - With both manifold valves closed, open the valve on the R407C cylinder (liquid only).
- 4 - Open the high pressure side of the manifold to allow R407C into the line set and indoor unit. Weigh in a trace amount of R407C. (A trace amount is a maximum of 59 ml or 21 kPa pressure.) Close the valve on the R407C cylinder and the valve on the high pressure side of the manifold gauge set. Disconnect R407C cylinder and attach a nitrogen cylinder.
- 5 - Adjust nitrogen pressure to 1034 kPa. Open the valve on the high side of the manifold gauge set which will pressurize line set and indoor unit.
- 6 - After a short period of time, open a refrigerant port to make sure the refrigerant added is adequate to be detected. (Amounts of refrigerant will vary with line lengths.) Check all joints for leaks. Purge nitrogen and R407C mixture. Correct any leaks and recheck.



## System Evacuation

### **⚠ WARNING**

**Unit contains a NITROGEN holding charge. The holding charge must be purged and the system must be evacuated prior to charging with R407C.**

Evacuating the system of non-condensables is critical for the unit to operate properly. Non-condensables are defined as any gas that will not condense under temperatures and pressures present during operation of an air conditioning system. Non-condensables and water vapor combine with refrigerant to produce substances that corrode copper piping and compressor parts.

1- Connect manifold gauge set to the service valve ports as follows:

- low pressure gauge to *suction* line service valve
- high pressure gauge to *liquid* line service valve

*IMPORTANT - Compliant scroll compressors (as with any refrigerant compressor) should never be used to evacuate a refrigeration or air conditioning system.*

*NOTE - Use a temperature vacuum gauge, mercury vacuum, or thermocouple gauge. The usual Bourdon tube gauges are inaccurate in the vacuum range.*

2 -The nitrogen holding charge in the unit must be released. Open both manifold valves to release the nitrogen from the unit. See the liquid and suction line service valves section for how to operate the service valves.

3 -Connect the vacuum pump (with vacuum gauge) to the center port of the manifold gauge set.

4 -Open both manifold valves and start the vacuum pump.

5 -Evacuate the line set, condensing unit, and indoor unit to an **absolute pressure** of 23 mm (23,000 microns) of mercury. During the early stages of evacuation, it is desirable to close the manifold gauge valve at least once to determine if there is a rapid rise in **absolute pressure**. A rapid rise in pressure indicates a relatively large leak. If this occurs, the leak testing procedure must be repeated.

*NOTE - The term **absolute pressure** means the total actual pressure within a given volume or system, above the absolute zero of pressure. Absolute pressure in a vacuum is equal to atmospheric pressure minus vacuum pressure.*

6 -When the absolute pressure reaches 23 mm (23,000 microns) of mercury, close the manifold gauge valves, turn off the vacuum pump, and disconnect the manifold gauge center port hose from the vacuum pump. Attach the manifold center port hose to a nitro-

gen cylinder with the pressure regulator set to 150 psig (1034 kPa) and purge the hose. Open the manifold gauge valves to break the vacuum in the system. Close the manifold gauge valves.

### **⚠ WARNING**

**Danger of Equipment Damage.**  
**Avoid deep vacuum operation. Do not use compressors to evacuate a system.**  
**Extremely low vacuums can cause internal arcing and compressor failure.**  
**Damage caused by deep vacuum operation will void warranty.**

7 -Shut off the nitrogen cylinder and remove the manifold gauge hose from the cylinder. Open the manifold gauge valves to release the nitrogen from the system.

8 -Reconnect the manifold gauge to the vacuum pump, turn the pump on and continue to evacuate the system until the absolute pressure does not rise above .5 mm (500 microns) of mercury within a 20-minute period after shutting off the vacuum pump and closing the manifold gauge valves.

9 - When the absolute pressure requirement from step 9 has been met, disconnect the manifold gauge hose from the vacuum pump. Then, weigh in a LIQUID charge of R407C through the liquid and suction service valves.

Refer to the unit nameplate for the correct liquid charge. If you can not measure in the total amount, refer to the start-up section and set the final system charge according to the charging instructions. **The R407C refrigerant cylinder should be chocolate brown.**

## Start-Up

### Cooling Start-Up

1 - Check the unit disconnect switch to make sure power is off.

2 - Rotate the fan to check for frozen bearings or binding.

3 - Inspect all factory and field-installed wiring for loose connections.

4 - Replace the stem caps. Tighten finger tight, then tighten an additional 1/6 turn.

5 - Check the voltage supply at the disconnect switch. The voltage must be within the range listed on the unit nameplate. If not, do not start the equipment until the you have consulted the power company, and the voltage condition has been corrected.

6 - Set the thermostat for cooling demand, turn on the power to the indoor blower coil, and close the heat pump unit disconnect switch to start the unit.

7 - Recheck the unit voltage while the unit is running. The power must be within the range shown on the unit nameplate. Check the amperage draw of the unit. Refer to the unit nameplate for approximate running amps.

**Charging**

Liquid charge the unit with the amount of R407C refrigerant that is indicated on the nameplate.

**⚠ IMPORTANT**

**If existing refrigerant lines which were previously charged with R22 are going to be used, they must first be flushed of existing mineral oil. Take care to empty all existing traps. Polyol ester (POE) oils are used in Lennox units charged with R407C refrigerant. Mineral oils are not compatible with polyol ester oils.**

This charge is based on a matching indoor coil and outdoor coil with a 4.6 m line set. For varying lengths of line set, refer to table 2 for refrigerant charge adjustment.

**TABLE 2**

Liquid Line Set Diameter	g per 1524 mm adjust from 4.6 m line set*
8 mm	57 g per 1524 mm
10 mm	85 g per 1524 mm

*\*If line length is greater than 4.6 m, add this amount.*

*If line length is less than 4.6 m, subtract this amount.*

**Charging Using the Subcooling Method**

If the outdoor ambient temperature is below 13°C, airflow over the outdoor coil will need to be reduced to drive up

the liquid line pressure to a range of 1379 to 1724 kPa. To do this, block off the outdoor coil with cardboard or a plastic sheet.

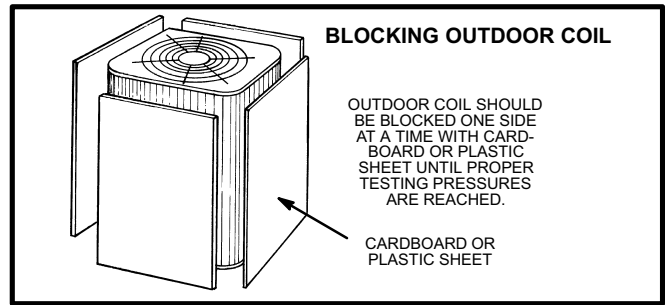

**FIGURE 9**

- 1 - Remove the cap from the liquid line service valve stem and turn the stem clockwise 1/4 to 1/2 turn. This will open the service port.
- 2 - With the manifold gauge hose still on the liquid service port and the unit operating, read the liquid line pressure.
- 3 - If the pressure is too low, block the airflow through the outdoor coil until the liquid line pressure stabilizes in a range from 1379 to 1724 kPa. At that time, record the liquid line temperature and the liquid line pressure reading.
- 4 - Use a temperature/pressure chart for R407C to determine the saturation temperature for the liquid line pressure reading.
- 5 - Subtract the liquid line temperature from the saturation temperature (according to the chart) to determine subcooling. **(Saturation temperature - Liquid line temperature = Subcooling.) Subcooling should be between 4.4-5.5°C.** If subcooling is greater than 4.4 - 5.5°C, recover some refrigerant. If subcooling is less than 4.4 - 5.5°C, add some refrigerant.

**TABLE 3**  
**R407C Saturated Liquid Temperature and Pressure Chart**  
**Use this chart for subcooling only, not superheat.**

Saturated Liquid Temperature °C	Liquid Line Pressure		Saturated Liquid Temperature °C	Liquid Line Pressure	
	R407C Psig (kPa)	R22 Psig (kPa)		R407C Psig (kPa)	R22 Psig (kPa)
15	116 (799)	102 (703)	33	197 (1358)	174 (1199)
16	118 (813)	104 (717)	33	200 (1378)	176 (1213)
16	120 (827)	105 (723)	34	203 (1399)	179 (1234)
17	123 (848)	107 (737)	35	206 (1420)	182 (1254)
17	125 (861)	109 (751)	35	210 (1447)	184 (1268)
18	127 (875)	111 (765)	36	213 (1468)	187 (1289)
18	129 (889)	113 (779)	36	216 (1489)	190 (1310)
19	131 (903)	115 (792)	37	219 (1509)	193 (1330)
20	134 (923)	117 (806)	37	222 (1530)	196 (1351)
20	136 (937)	119 (820)	38	226 (1558)	199 (1372)
21	138 (951)	121 (834)	38	229 (1578)	202 (1392)
21	141 (972)	123 (848)	39	232 (1599)	205 (1413)
22	143 (985)	126 (868)	40	236 (1627)	208 (1431)
22	146 (1006)	128 (882)	40	239 (1647)	211 (1454)
23	148 (1020)	130 (896)	41	242 (1668)	214 (1475)
23	151 (1041)	132 (910)	41	246 (1696)	217 (1496)
24	153 (1054)	134 (923)	42	249 (1716)	220 (1516)
25	156 (1075)	137 (944)	42	253 (1744)	223 (1537)
25	158 (1089)	139 (958)	43	257 (1771)	226 (1558)
26	161 (1110)	141 (972)	43	260 (1792)	229 (1578)
26	163 (1123)	144 (992)	44	264 (1820)	233 (1606)
27	166 (1144)	146 (1006)	45	268 (1847)	236 (1627)
27	169 (1165)	148 (1020)	45	271 (1868)	239 (1647)
28	171 (1179)	151 (1041)	46	275 (1896)	243 (1675)
28	174 (1199)	153 (1054)	47	279 (1923)	246 (1696)
29	177 (1220)	156 (1075)	47	283 (1951)	250 (1723)
30	180 (1241)	158 (1089)	47	287 (1978)	253 (1744)
30	183 (1261)	161 (1110)	48	290 (1999)	256 (1765)
31	186 (1282)	163 (1123)	48	294 (2027)	260 (1792)
31	188 (1296)	166 (1144)	51	315 (2171)	278 (1916)
32	191 (1316)	168 (1158)	54	336 (2316)	297 (2047)
32	194 (1337)	171 (1179)	57	358 (2468)	317 (2185)

## System Operation

### Filter Drier

The unit is equipped with a biflow filter drier. See figure 6. If the filter needs to be replaced, order another of the same design.

### Thermostat Operation

Some heat pump thermostats incorporate isolating contacts and an emergency heat function (which includes an amber indicating light). The thermostat is not included with the unit and must be purchased separately.

### Emergency Heat Function

Some thermostats have an emergency heat function. This feature is applicable only to those systems that have auxiliary electric heat staged by outdoor thermostats. When the thermostat is placed in the emergency heat position, the outdoor unit control circuit is isolated from the power source, and field-provided relays bypass the outdoor thermostats. An amber indicating light simultaneously comes on to remind the homeowner that the unit is operating in the emergency heat mode.

Emergency heat is usually used during a heat pump shutdown. However, emergency heat should also be used following a power outage if the power has been off for over an hour, and the outdoor temperature is below 10°C. The

system should be left in the emergency heat mode for at least six hours to allow the crankcase heater sufficient time to prevent compressor from slugging.

## Defrost System

The HP40 defrost system includes two components: a defrost thermostat and a defrost control.

### Defrost Thermostat

The defrost thermostat is located on the liquid line between the check/expansion valve and the distributor. When defrost thermostat senses 5.5°C or cooler, the thermostat contacts close and send a signal to the defrost control board to start the defrost timing. It also terminates defrost when the liquid line warms up to 21°C.

### Defrost Control

The defrost control board includes the combined functions of a time/temperature defrost control, defrost relay, diagnostic LEDs and terminal strip for field wiring connections. See figure 10.

The control provides automatic switching from normal heating operation to defrost mode and back. During compressor cycle (call for defrost), the control accumulates compressor run times at 30, 60, or 90 minute field-adjustable intervals. If the defrost thermostat is closed when the selected compressor run time interval ends, the defrost relay is energized and defrost begins.

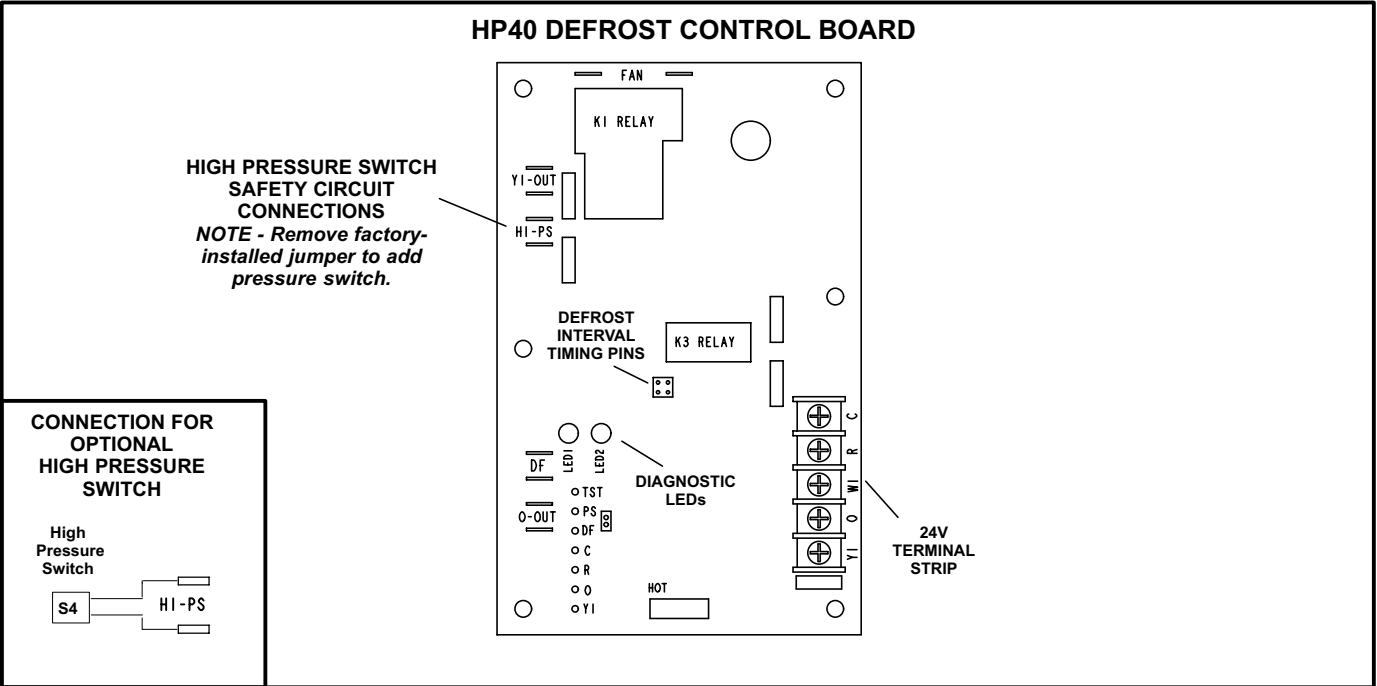

FIGURE 10

## Defrost Control Timing Pins

Each timing pin selection provides a different accumulated compressor run time period during one thermostat run cycle. This time period must occur before a defrost cycle is initiated. The defrost interval can be adjusted to 30 (T1), 60 (T2), or 90 (T3) minutes. See figure 10. The defrost timing jumper is factory-installed to provide a 60-minute defrost interval. If the timing selector jumper is not in place, the control defaults to a 90-minute defrost interval. The maximum defrost period is 14 minutes and cannot be adjusted.

A TEST option is provided for troubleshooting. **The TEST mode may be started any time the unit is in the heating mode and the defrost thermostat is closed or jumpered.** If the jumper is in the TEST position at power-up, the control will ignore the test pins. When the jumper is placed across the TEST pins for two seconds, the control will enter the defrost mode. If the jumper is removed before an additional 5-second period has elapsed (7 seconds total), the unit will remain in defrost mode until the defrost thermostat opens or 14 minutes have passed. If the jumper is not removed until after the additional 5-second period has elapsed, the defrost will terminate and the test option will not function again until the jumper is removed and re-applied.

## Pressure Switch Circuit

The defrost control incorporates a pressure switch circuit that allows the application of an optional high pressure switch. See figure 10. During a demand cycle, the defrost control will lock out the unit if the optional high pressure switch opens. The diagnostic LEDs will display a pattern for an open high pressure switch. See table 3. The unit will remain locked out until the switch resets or is reset.

Remove the factory-installed jumper before connecting the optional high pressure switch to the control board.

*NOTE - If not using a pressure switch, the factory-installed jumper wire must be connected.*

## Diagnostic LEDs

The defrost board uses two LEDs for diagnostics. The LEDs flash a specific sequence according to the condition.

**TABLE 3**

DEFROST CONTROL BOARD DIAGNOSTIC LED		
MODE	LED 1	LED 2
Normal operation / power to board	Synchronized Flash with LED 2	Synchronized Flash with LED 1
Board failure or no power	Off	Off
Board failure	On	On
High pressure switch open	Flash	On

## Maintenance

### **WARNING**



**Electric shock hazard. Can cause injury or death. Before attempting to perform any service or maintenance, turn the electrical power to unit OFF at disconnect switch(es). Unit may have multiple power supplies.**

At the beginning of each heating or cooling season, check the system as follows:

### Heat Pump Unit

- 1 - Clean and inspect the outdoor coil. You may flush the coil with a water hose. Make sure the power is off before you clean the coil.
- 2 - The outdoor unit fan motor is pre-lubricated and sealed. The fan motor requires no more lubrication.
- 3 - Inspect all connecting lines, joints, and coils for evidence of oil leaks.
- 4 - Check all wiring for loose connections.
- 5 - Check for correct voltage at the unit while the unit is operating.
- 6 - Check amp draw on the heat pump fan motor.  
Unit nameplate \_\_\_\_\_ Actual \_\_\_\_\_.
- 7 - Inspect the drain holes in the coil compartment base and clean them if necessary.

*NOTE - If insufficient heating or cooling occurs, gauge the unit and check the refrigerant charge.*

### Indoor Coil

- 1 - If necessary, clean the coil.
- 2 - Inspect the connecting lines, joints, and coil for evidence of oil leaks.
- 4 - Check all wiring for loose connections.
- 5 - Check for correct voltage at the unit.
- 6 - Check the amp draw on the blower motor.  
Motor nameplate \_\_\_\_\_ Actual \_\_\_\_\_.
- 3 - Check the condensate line and clean it if necessary.

### Indoor Unit

- 1 - Clean or change the filters.
- 2 - Lennox blower motors are pre-lubricated and permanently sealed. The blower motor requires no more lubrication.
- 3 - Adjust the blower speed for cooling. Measure the pressure drop over the coil to determine the correct blower m<sup>3</sup>/s.

**Start-Up and Performance Check List**

Job Name \_\_\_\_\_ Job No. \_\_\_\_\_ Date \_\_\_\_\_

Job Location \_\_\_\_\_ City \_\_\_\_\_ State \_\_\_\_\_

Installer \_\_\_\_\_ City \_\_\_\_\_ State \_\_\_\_\_

Unit Model No. \_\_\_\_\_ Serial No. \_\_\_\_\_ Service Technician \_\_\_\_\_

Nameplate Voltage \_\_\_\_\_ Amps: \_\_\_\_\_

Minimum Circuit Ampacity \_\_\_\_\_ Supply \_\_\_\_\_ Outdoor Fan \_\_\_\_\_

Maximum Overcurrent Protection Size \_\_\_\_\_ Compressor \_\_\_\_\_

Electrical Connections Tight?

Indoor Filter Clean?

Supply Voltage (Unit Off) \_\_\_\_\_

Indoor Blower RPM \_\_\_\_\_

**COOLING SECTION**

S.P. Drop Over Evaporator (Dry) \_\_\_\_\_

Refrigerant Lines:

Outdoor Coil Entering Air Temperature \_\_\_\_\_

Leak Checked?

Discharge Pressure \_\_\_\_\_ Suction Pressure \_\_\_\_\_

Properly Insulated?

Refrigerant Charge Checked?

Outdoor Fan Checked?

Service Valve Caps Tight?

**THERMOSTAT**

Service Valves Fully Opened?

Calibrated?

Properly Set?

Voltage With Compressor Operating \_\_\_\_\_

Level?



***LENNOX***<sup>®</sup>

**Lennox Industries**  
P.O. Box 174, Westgate Interchange,  
Northampton NN5 5AG

Telephone: 01604 591159  
Facsimile: 01604 587536

