

INDICE	
REGLETERO CONEXIONES ELECTRICAS TERMINAL STRIP BORNIER DE CONNEXION ELECTRIQUE KLEMMLEISTE AANSLUITSTRIP	HOJA 1/7
CIRCUITO POTENCIA POWER CIRCUIT CIRCUIT DE PUISSANCE STROMKREIS HOOFDSTROOMCIRCUIT	HOJA 2/7
CIRCUITO MANIOBRA CONTROL CIRCUIT CIRCUIT DE CONTROL STEUERKREIS REGELCIRCUIT	HOJA 3/7
CIRCUITO SEÑALIZACION SIGNAL CIRCUIT CIRCUIT DE SIGNALISATION ALAMKREIS ALARMCIRCUIT	HOJA 4/7
CONEXION OPCIONALES OPTIONS CONNEXIONS OPCIONNELS OPTIONEN / ZUBEHÖR OPTIES	HOJA 5-6/7
LEYENDA REFERENCIAS REFERENCES LEGEND REFERENCE DE LEGENDE LEGENDE VERKLARING LEGENDA	HOJA 7/7



ESQUEMA ELECTRICO  
WIRING DIAGRAM  
SCHEMA ELECTRIQUE  
SCHALTPLAN  
ELECTRISCH SCHEMA

Elemento Opcional  
Optional Element  
Elément optionnel  
Optionales bauteil  
Optioneel element

-----

A realizar por el instalador  
To wire by the installer  
A câbler par l'installateur  
Verdrahtung durch den installateur  
Installateurzijdig te bedraden

-----



Lennox Refac S.A.

ESQUEMA ELECTRICO  
ELECTRIC DIAGRAM

ANHK (LEHK+KNHK)  
48D-64D-76D-86D

4Z-33-439-409 17C  
3N 400V 50Hz + PE  
3 ~ 230V 50Hz + PE

⚠ LA MANGUERA APANTALLADA DEBE CONECTARSE A TIERRA  
 THE CABLE SCREEN MUST BE CONNECTED TO GROUND  
 LA TRESSE DE BLINDAGE DOIT SE CONNECTER A LA TERRE  
 DIE KABELABSCHIRMUNG MUSS GEERDET WERDEN  
 DE AFSCHERMING MOET AAN AARDE VERBONDEN WORDEN

1 RETIRAR PUENTE SI SE MONTA ON/OFF REMOTO  
 REMOVE LINK FOR REMOTE ON/OFF OPERATION  
 RETIRER LE POND S'IL Y A MARCHE/ARRET A DISTANCE  
 ENTFERNE DIE VERBINDUNG ZUM EIN/AUS FERNSCHALTER  
 VERWIJDER LIK BIJ REMOTE ON/OFF

2 ESTAS BORNAS SOLAMENTE SE INCLUYEN CON SU OPCIONAL  
 THESE TERMINALS ARE ONLY INCLUDED WITH ITS OPTIONAL  
 CES CONTACTS SONT INSTALLES SEULEMENT SI ON DEMANDE LEUR OPTIONEL  
 DIESE ANSCHLUSSKLEMMEN SIND NUR MIT ZUBEHÖR VERFÜGBAR IHREM  
 DEZE AANSLUITKLEMMEN ZIJN ALLEEN VOORZIEN BIJ TOEPASSING VAN HUN OPTIONELE

VER MANUAL INSTALACION  
 SEE INSTALLATION MANUAL (IOM)  
 VOIR LE MANUEL D'INSTALLATION  
 SIEHE INSTALLATIONSHANDBUCH (IOM)  
 ZIE INSTALLATION MANUAL (IOM)

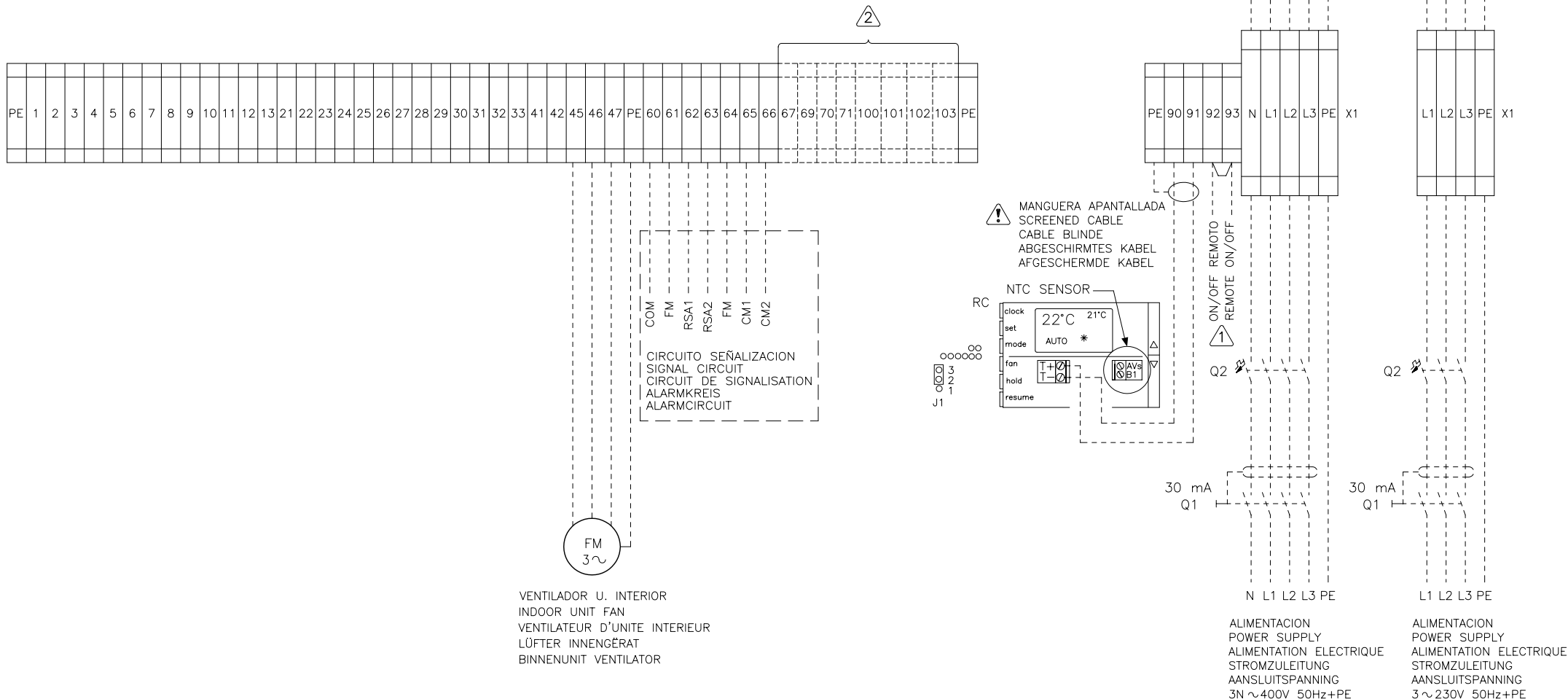

VENTILADOR U. INTERIOR  
 INDOOR UNIT FAN  
 VENTILATEUR D'UNITE INTERIEUR  
 LÜFTER INNENGERÄT  
 BINNENUNIT VENTILATOR

ALIMENTACION  
 POWER SUPPLY  
 ALIMENTATION ELECTRIQUE  
 STROMZULEITUNG  
 AANSLUITSPANNING  
 3N ~ 400V 50Hz+PE

ALIMENTACION  
 POWER SUPPLY  
 ALIMENTATION ELECTRIQUE  
 STROMZULEITUNG  
 AANSLUITSPANNING  
 3 ~ 230V 50Hz+PE

Elemento Opcional  
 Optional Element  
 A Realizar por el Instalador  
 To Wire by the Installer

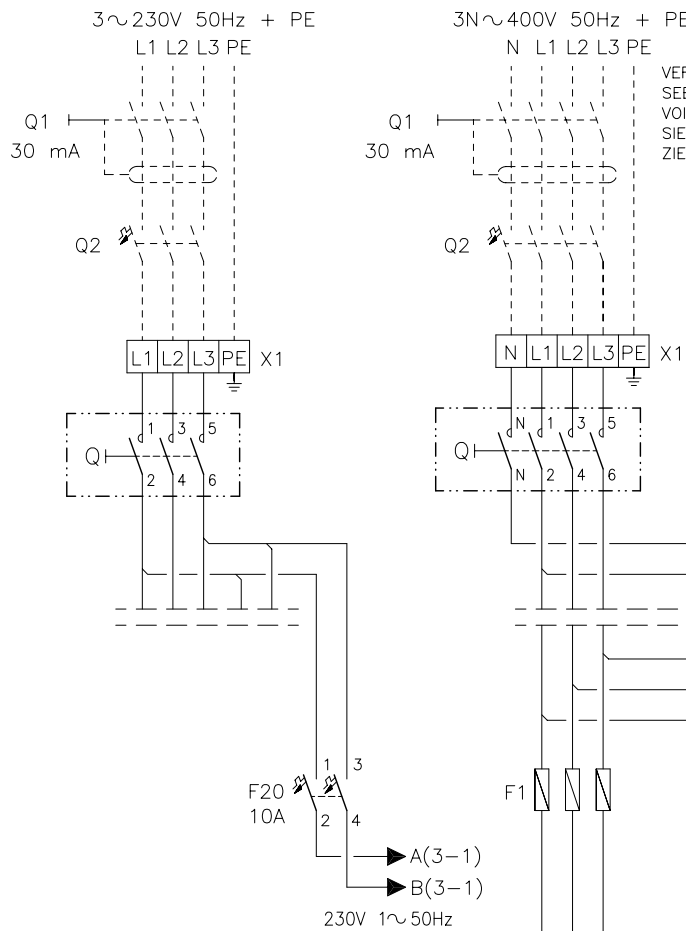

VER MANUAL INSTALACION  
SEE INSTALLATION MANUAL (IOM)  
VOIR LE MANUEL D'INSTALLATION  
SIEHE INSTALLATIONSHANDBUCH (IOM)  
ZIE INSTALLATION MANUAL (IOM)

FUSIBLES FUSES FUSIBLES SICHERUNGEN ZEKERINGEN		ANHK 48D-64D-76D-86D			
		48D	64D	76D	86D
400V 3~50Hz	F1-2(CM1-2)	6x20A	6x25A	6x32A	6x40A
	F5(FM)	3x10A	3x10A	3x10A	3x16A
230V 3~50Hz	F1-2(CM1-2)	6x40A	6x50A	6x63A	6x80A
	F5(FM)	3x16A	3x16A	3x16A	3x25A
230V 1~50Hz	F3(CFM1-2)	1x10A	1x10A	1x10A	1x10A

INTENSIDAD CURRENT INTESITÉ STROM STROOM		ANHK 48D		ANHK 64D		ANHK 76D		ANHK 86D	
		Im(MCC)	Ia(LRA)	Im(MCC)	Ia(LRA)	Im(MCC)	Ia(LRA)	Im(MCC)	Ia(LRA)
400V 3~50Hz	CM(1-2)	15,1A	94,0A	20,7A	127A	25,6A	158A	29,8A	189A
	FM	5,1A	—	7,2A	—	7,2A	—	11,9A	—
230V 3~50Hz	CM(1-2)	27,2A	166A	37,2A	224A	46,1A	279A	53,6A	330A
	FM	8,9A	—	12,5A	—	12,5A	—	20,6A	—
230V 1~50Hz	CFM(1-2)	3,5A	—	4,5A	—	4,5A	—	4,5A	—

FUSIBLES BATERÍA ELEC. FUSES ELEC. HEATER FUSIBLES RESISTENCE ÉLEC. SICHERUNGEN E.-HEIZUNG ZEKRING ELECTRISCHE VERHITTER	ANHK 48D-64D-76D-86D			
	48D-64D-76D	48D-64D-76D-86D	48D-64D-76D-86D	
400V 3~50Hz	F7(EH)	3x16A	3x20A	3x32A
		7,5kW 1ST	11kW 1ST	15kW 1ST
230V 3~50Hz	F7(EH)	3x25A	3x40A	3x50A

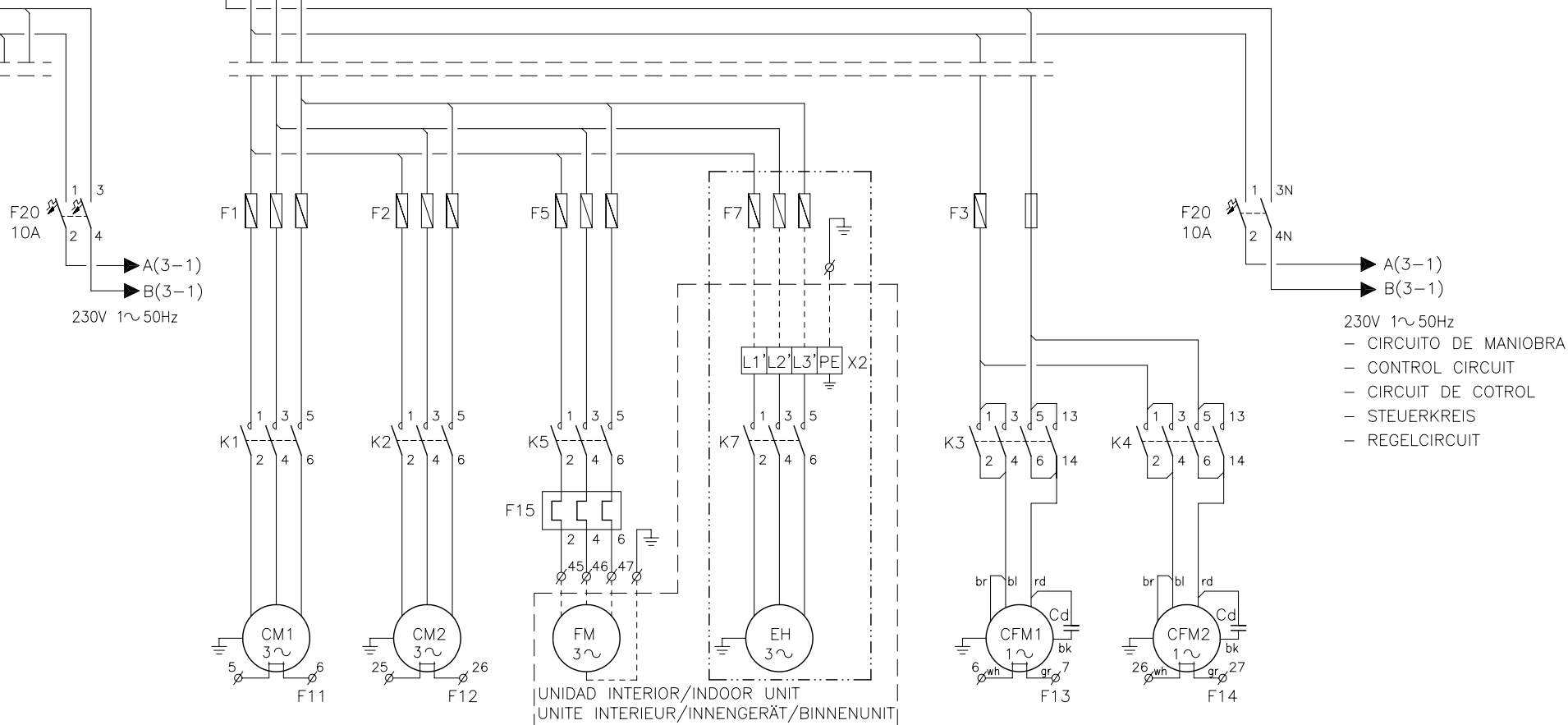

- 230V 1~50Hz
- CIRCUITO DE MANIOBRA
  - CONTROL CIRCUIT
  - CIRCUIT DE COTROL
  - STEUERKREIS
  - REGELCIRCUIT

Elemento Opcional  
Optional Element  
A Realizar por el Instalador  
To Wire by the Installer

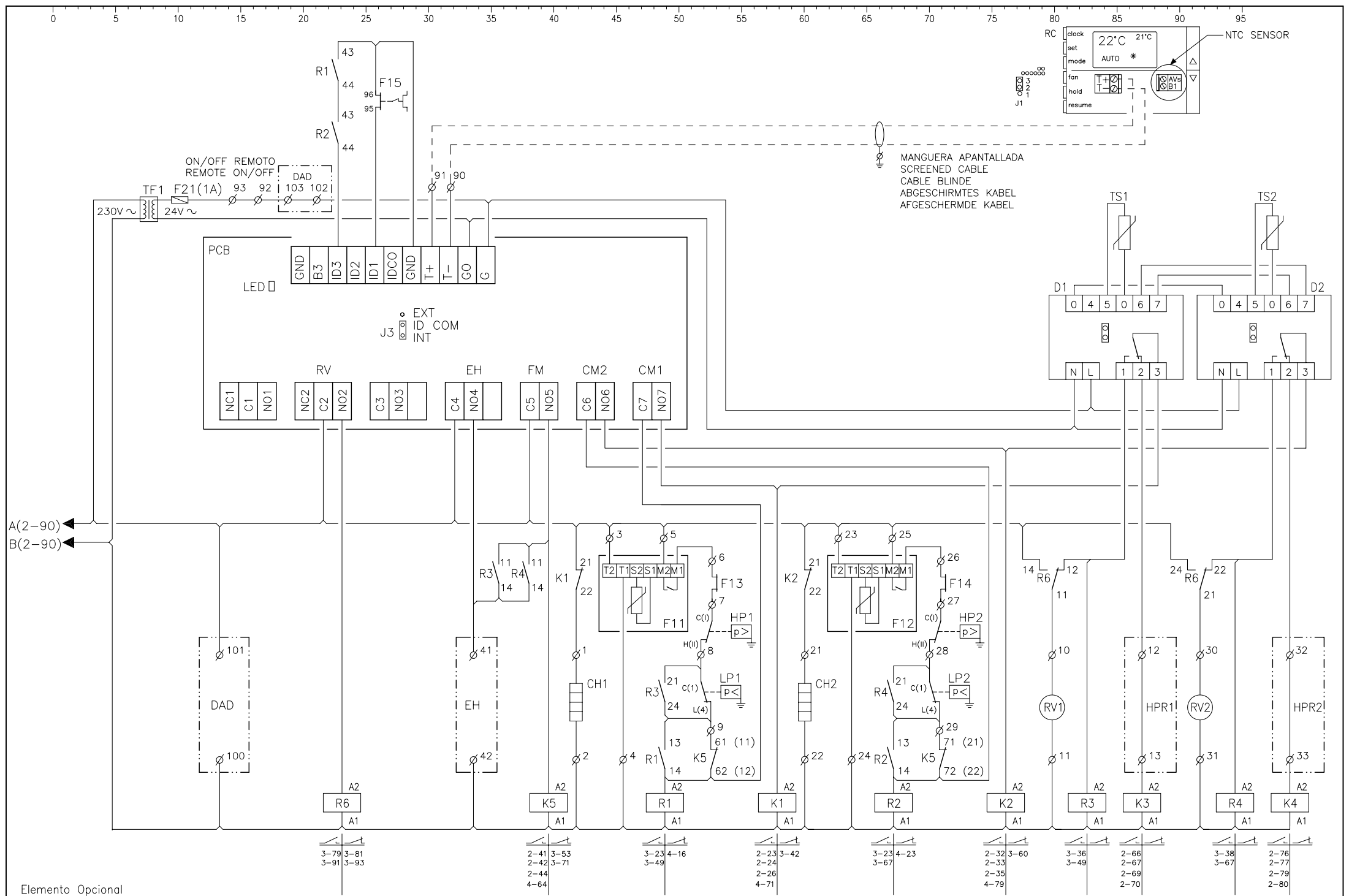

MANGUERA APANTALLADA  
 SCREENED CABLE  
 CABLE BLINDE  
 ABGESCHIRMTES KABEL  
 AFGESCHERMD KABEL

Elemento Opcional  
 Optional Element  
 A Realizar por el Instalador  
 To Wire by the Installer

3/7

Lennox Refac S.A.

ESQUEMA ELECTRICO  
 ELECTRIC DIAGRAM

ANHK (LEHK+KNHK)  
 48D-64D-76D-86D

4Z-33-439-409 17C  
 3N 400V 50Hz + PE  
 3 ~ 230V 50Hz + PE

CIRCUITO SEÑALIZACION  
 SIGNAL CIRCUIT  
 CIRCUIT DE SIGNALISATION  
 ALAMKREIS  
 ALARMCIRCUIT

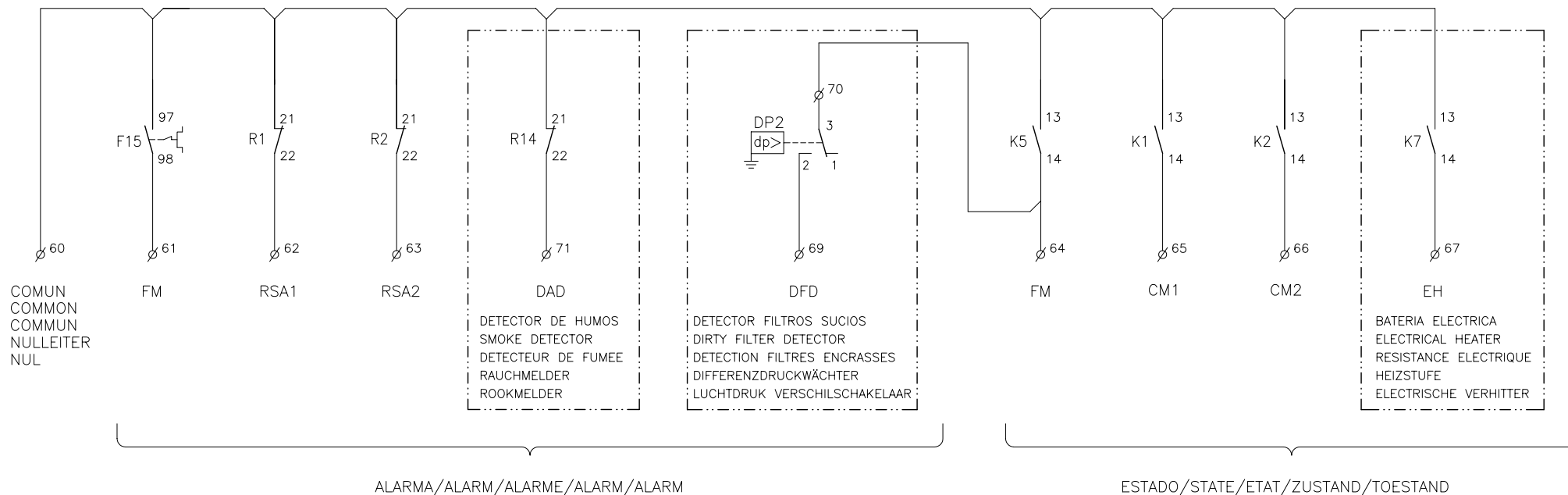

Elemento Opcional  
 Optional Element  
 A Realizar por el Instalador  
 To Wire by the Installer

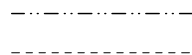

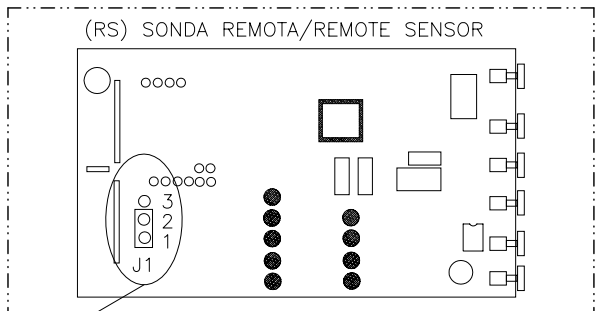

COLOCAR PUENTE J1 ENTRE 1-2 SONDA TEMPERATURA REMOTA  
 ISET JUMPER J1 BETWEEN 1-2 FOR REMOTE TEMPERATURE SENSOR  
 INSERER UN POND ENTRE J1 ET 1-2 SONDE DE TEMPERATURE A DISTANCE  
 ISETZE JUMPER J1 ZWISCHEN 1-2 FÜR FERNTEMPERATURFÜHLER  
 PLAATS JUMPER J1 TUSSEN 1-2 VOOR AFSTANDTEMPERATUURVOELER

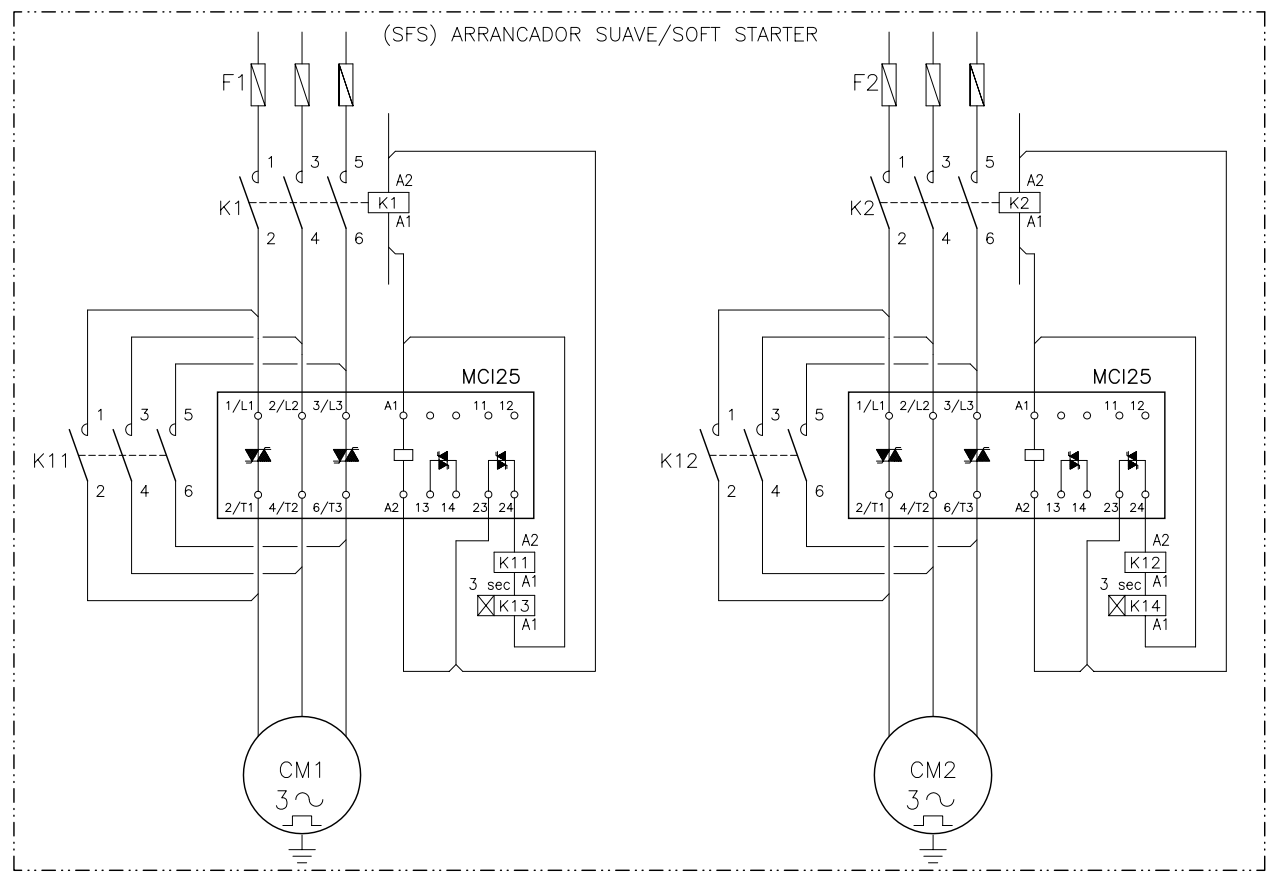
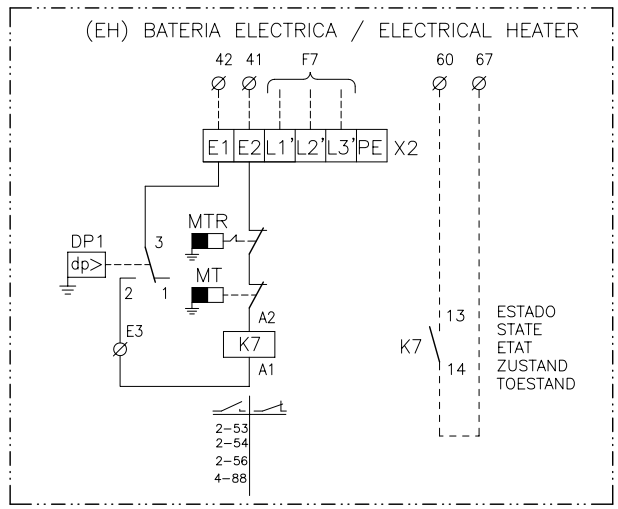
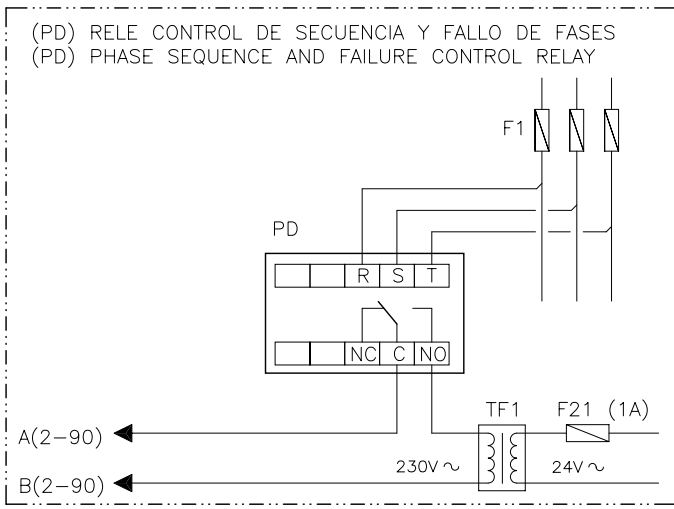
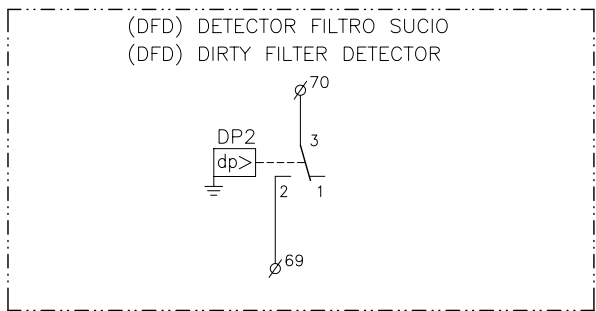
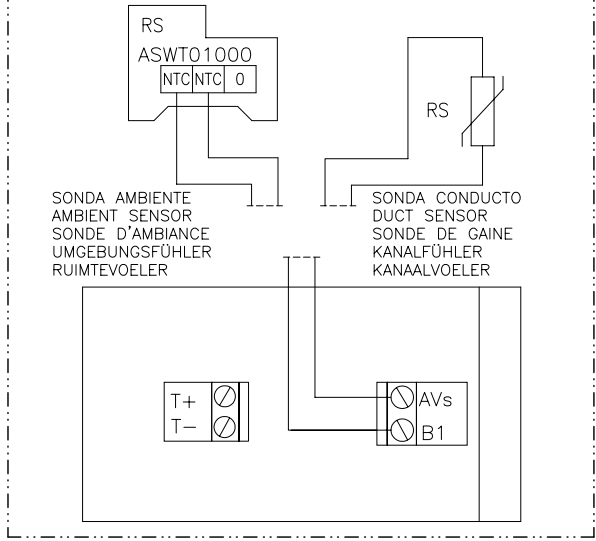

Elemento Opcional  
 Optional Element  
 A Realizar por el Instalador  
 To Wire by the Installer

(HPR) CONTROL CONDENSACION TODO/NADA  
(HPR) WINTER CONTROL ON/OFF

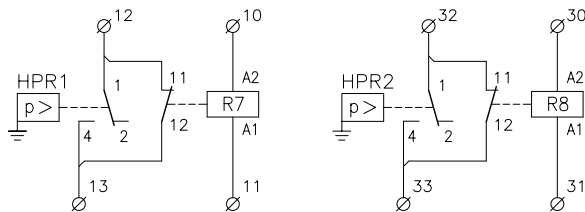

TARADO DE HPR: CORTE 14BAR REARME 17BAR / HPR SETPOINT: OFF 14BAR RESET 17BAR  
REGLAGE HPR: COUPURE 14BAR REARMEMENT 17BAR / HD-PRESSOSTAT: AUS BEI 14BAR RESET BEI 17BAR  
HD SETPOINT: OFF 14BAR RESET 17BAR

RETIRAR PUENTE SI SE MONTA HPR / REMOVE LINK FOR HPR OPERATION / RETIRER LE POND S'IL Y A HPR /  
ENTFERNE DIE VERBINDUNG ZUM HD-PRESSOSTAT / VERWIJDER LINK BIJ HD BEDRIJF

(FSC) CONTROL DE CONDENSACION/FAN SPEED CONTROL

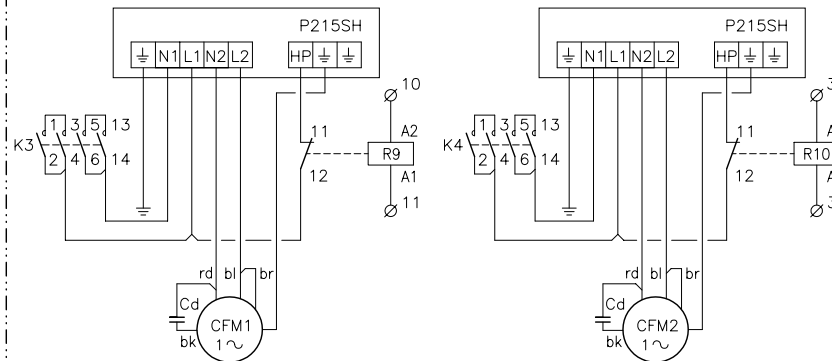

(BY) KIT BY PASS DE GAS CALIENTE  
(BY) KIT HOT GAS BY PASS

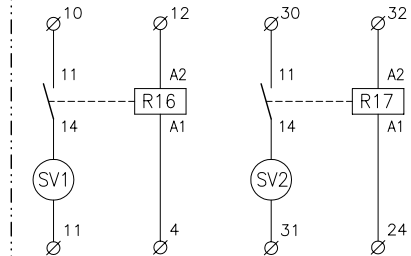

(DAD) CONTROL DETECCION DE HUMOS/SMOKE DETECTION CONTROL

CUADRO ELECTRICO DAD/ELECTRICAL BOARD DAD  
COFFRET ELECTRIQUE DAD/PLATINE FÜR DAD/PRINT VOOR DAD

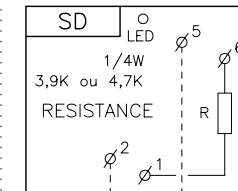
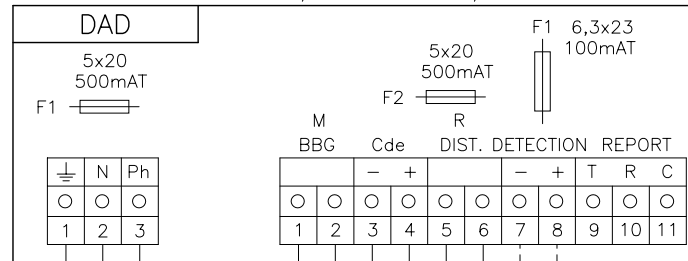

CUADRO PRINCIPAL/MAIN ELECTRICAL BOARD/COFFRET ELECTRIQUE/HAUPTPLATINE/HOOFDSTROOMPANEEL

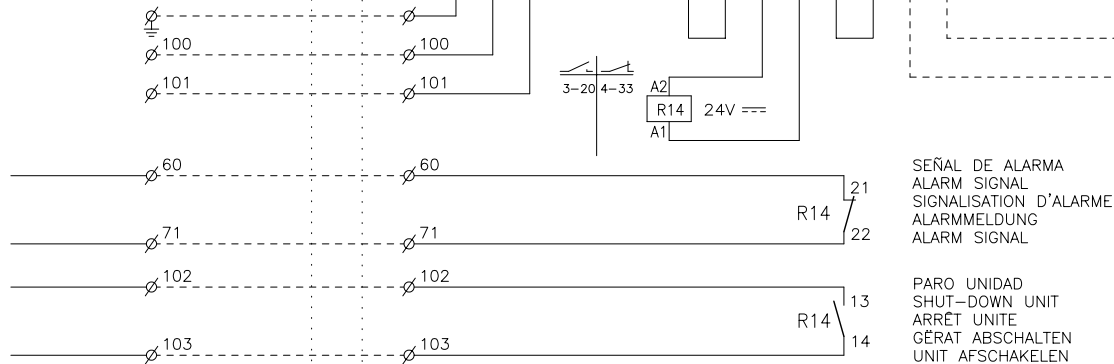

RETIRAR PUENTE SI SE MONTA DAD  
REMOVE LINK FOR DAD OPERATION  
RETIRER LE POND S'IL Y A DAD  
ENTFERNE DIE VERBINDUNG ZUM DAD  
VERWIJDER LIK BIJ DAD

SEÑAL DE ALARMA  
ALARM SIGNAL  
SIGNALISATION D'ALARME  
ALARMMELDUNG  
ALARM SIGNAL

PARO UNIDAD  
SHUT-DOWN UNIT  
ARRÊT UNITE  
GERÄT ABSCHALTEN  
UNIT AFSCHAKELLEN

Elemento Opcional  
Optional Element  
A Realizar por el Instalador  
To Wire by the Installer

	LEYENDA	LEGEND	REFERENCE	LEGENDE	LEGENDA
BY	Kit by pass de gas caliente	Kit hot gas by pass	By-pass de gaz chaud	Heissgasbypass	Hot gas by-pass
Cd	Condensador	Condenser	Condenseur	Kondensator	Condensator
CH	Resistencia de carter	Crankcase heater	Résistance de carter	Kurbelwannenheizung	Carterverwarming
CFM	Motor ventilador exterior	Compressor fan motor	Moteur ventilateur extérieur	Kondensatorlüftermotor	Condensator ventilador motor
CM	Motor compresor	Compressor motor	Compresseur	Kompressor	Compressor motor
D1-2	Control desescarche	Defrost control	Contrôleur de dégiurage	Abtauregler	Ontdooi regeling
DAD	Control detección de humos	Smoke detection control	Détecteur fumée	Rauchmelder	Rookdetector
DFD	Detector filtros sucios	Dirty filter detector	Détection filtres encrassés	Differenzdruckwächter	Luchtdruk verschilshakelaar
DP	Presostato diferencial aire	Air pressure differential switch	Pressostat diferencial d'air	differentialluftdruckschalter	Luft druck difereciaal schalter
EH	Batería eléctrica	Electrical heater	Résistance électrique	Heizstufe	Electrische verhitter
FM	Motor ventilador interior	Indoor fan motor	Moteur du ventilateur intérieur	Innenventilatormotor	Verdamper ventilatormotor
FSC	Control de condensación	Fan speed control	Variateur de vitesse du ventilateur	Kondensationsdruckregelung	Ventilator snelheidsregelaar
F1-7	Fusibles	Fuses	Fusibles	Sicherungen	Zekeringen
F11-12	Módulo protección compresor	Compressor protector module	Module protection du compresseur	Therm. kompressorrelais	Compressor beveiligings module
F13-15	Protección térmica	Thermal protection	Protection thermique	Therm. kompressorrelais	Compressor thermische beveiliging
F20	Magnetotérmico	Circuitbraker	Magneto thermique	Motorschuttschalter	Thermisch relais
F21	Fusible del TF1	TF1 fuse	Fusible TF1	TF1 schütz	TF1 zekering
HP1-2	Presostato de alta	High pressure pressostat	Pressostat HP	Hochdruckpressostat	Hoge druck pressostaat
HPR1-2	Control condensación TODO/NADA	Winter control ON/OFF	C. pression condensation ON/OFF	K. druckregelung ON/OFF	Winter regeling AAN/UIT
Ia(LRA)	Intensidad de arranque	Starting current	Intensité de démarrage	Anlaufstrom	Opstart stroom
Im(MCC)	Intensidad máxima	Maximum current	Intensité maximum	Maximale stromstärke	Maximaal stroom
J1,3	Puente	Jumper	Pont	Jumper	Jumper
K	Contacto	Contacto	Contacteur	schütz	Relais
LP1-2	Presostato baja	Low pressure pressostat	Pressostat BP	Niederdruckpressostat	Lagedruk beveiling
MT	Termostato seguridad (70°C automático)	Safety thermostat (open 70°C autom. reset)	T. securité (70°C automatique)	Sicherheitsther. (70°C automatisch)	T. beveiliging (70°C autoreset)
MTR	Termostato seguridad (105°C manual)	Safety thermostat (open 105°C manu. reset)	T. securité (105°C manuel)	Sicherheitsther. (150°C manuell)	T. beveiliging (105°C handreset)
PCB	Placa control	Printed circuit board	Carte électronique	Steuerplatine	Printboard
PD	Relé control de secuencia-fallo de fases	Phase sequence and failure control relay	Détecteur de phase	Phasenfolgenüberwachung+Störemel	Fasevolgorde-foutcontrole relais
Q	Interruptor general	Main switch	Interrupteur général	Hauptschalter	Hoofdschakelaar
Q1	Interruptor diferencial	Ground safety switch	Interrupteur différentiel	Schalter	Aardlekschakelaar
Q2	Interruptor magnetotérmico	Circuit breaker	Interrupteur magneto thermique	Motorschuttschalter	Magneetschakelaar
R3-17	Relé auxiliar	Auxiliary relay	Relais auxiliaire	Hilfsrelais	Aux. relais
RC	Control remoto	Remote control	Contrôle à distance	Fernbedienung	Afstandsbediening
RS	Sonda remota ambiente	Ambient remote sensor	Sonde temp. ambiente a distance	Umgebungsfernfühler	Ruimtevoeler
RSA1-2	Relé señal alarma	Alarm signal relay	Relais défaut à distance	Störmelderrelais	Storingrelais
RV1-2	Válvula inversora (frío ON)	Reverse valve (cooling ON)	Vanne renversée (refroidissement)	Umschaltrelais (kühlen ON)	Omkeerklep (koel=bekrachtigd)
SD	Sensor detector de humos	Smoke detection sensor	Sonde de détection de fumée	Rauchmelder	Rookmelder
SFS	Arrancador suave	Soft starter	Démarrreur progressif	Softstarter/Sanftanlauf	Soft starter
SV1-2	Válvula solenoide	Solenoid valve	Vanne solénoïde	Magnetventil	Magneet ventiel
TF1	Transformador	Transformer	Transformateur	Transformator	Transformator
TS1-2	Sonda temp. batería unidad exterior	Outdoor unit coil temperature sensor	Sonde temp. de batterie extérieur	Temperaturfühler kondensator	Buitenunit bloktemp. opnemer
	CODIGO DE COLORES	COLOUR CODE	CODE COLEUR	FARBKENNUNG	KLEURCODE
bk	negro	black	noir	schwarz	zwart
br	marrón	brown	brun	braun	bruin
rd	rojo	red	rouge	rot	rood
or	naranja	orange	orange	orange	oranje
yl	amarillo	yellow	jaune	gelb	geel
gn	verde	green	vert	grün	groen
bl	azul	blue	bleu	blau	blauw
vi	violeta	violet	violet	viollet	violet
gr	gris	gray	gris	grau	grijs
wh	blanco	white	blanc	weiss	wit