

0 5 10 15 20 25 30 35 40 45 50 55 60 65 70 75 80 85 90 95

INDICE	
REGLETERO CONEXIONES ELECTRICAS TERMINAL STRIP BORNIER DE CONNEXION ELECTRIQUE KLEMMLEISTE AANSLUITSTRIP	HOJA 1/9
CIRCUITO POTENCIA POWER CIRCUIT CIRCUIT DE PUISSANCE STROMKREIS HOOFDSTROOMCIRCUIT	HOJA 2/9
CIRCUITO MANIOBRA CONTROL CIRCUIT CIRCUIT DE CONTROL STEUERKREIS REGELCIRCUIT	HOJA 3-4/9
CONEXION OPCIONALES OPTIONS CONNEXIONS OPTIONNELS OPTIONEN / ZUBEHÖR OPTIES	HOJA 5-8/9
LEYENDA REFERENCIAS REFERENCES LEGEND REFERENCE DE LEGENDE LEGENDE VERKLARING LEGENDA	HOJA 9/9



ESQUEMA ELECTRICO
WIRING DIAGRAM
SCHEMA ELECTRIQUE
SCHALTPLAN
ELECTRISCH SCHEMA

Elemento Opcional
Optional Element
Element optionnel
Optionales bauteil

A realizar por el instalador
To wire by the installer
A câbler par l'installateur
Verdrahtung durch den installateur

%

Lennox Refrac S.A.

ESQUEMA ELECTRICO
ELECTRIC DIAGRAM

ANCK 128D-152D C50

4Z-33-44-309 23H
3N~400V 50Hz + PE

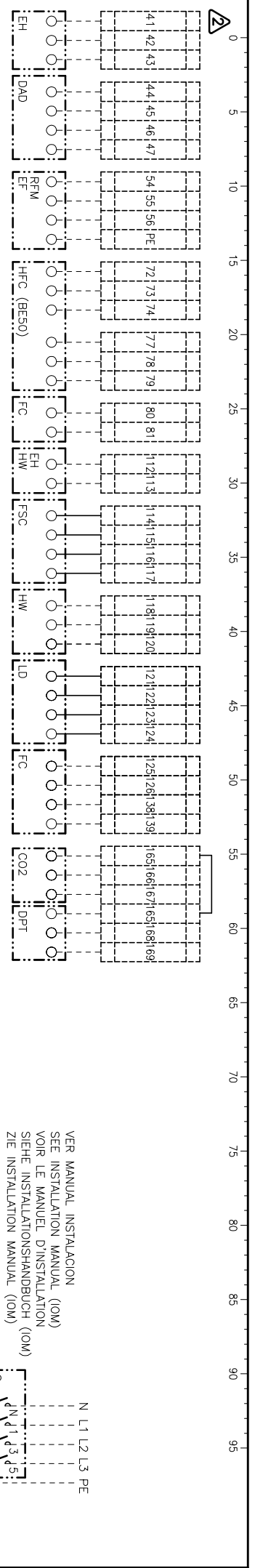

VER MANUAL INSTALACION
 SEE INSTALLATION MANUAL (IOM)
 VOIR LE MANUEL D'INSTALLATION
 SIEHE INSTALLATIONSHANDBUCH (IOM)
 ZIE INSTALLATION MANUAL (IOM)

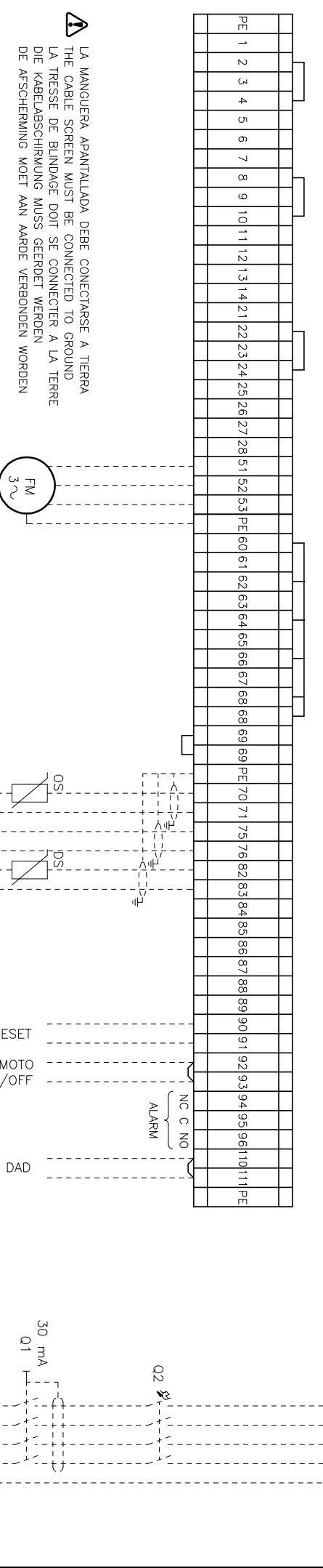

A LA MANGUERA APANTALLADA DEBE CONECTARSE A TIERRA
 THE CABLE SCREEN MUST BE CONNECTED TO GROUND
 LA TRESSÉ DE BLINDAGE DOIT SE CONNECTER A LA TERRE
 DIE KABELABSCHIRMUNG MUSS GEERDET WERDEN
 DE AFSCHERMING MOET AAN AARDE VERBONDEN WORDEN

A RETIRAR PUENTE SI SE MONTA ON/OFF REMOTO
 REMOVE LINK FOR REMOVE ON/OFF OPERATION
 RETIRER LE POND STL Y A MARCHE/ARRÊT A DISTANCE
 ENTFERNEN DIE VERBINDUNG ZUM EIN/AUS FERNSCHALTER
 VERWUDER LIK BIJ REMOTE ON/OFF

A ESTAS BORNAS SOLAMENTE SE INCLUYEN CON SU OPCIONAL
 THESE TERMINALS ARE ONLY INCLUDED WITH ITS OPTIONAL
 CES CONTACTS SONT INSTALÉS SEULEMENT SI ON DEMANDE LEUR OPTIONNEL
 DIESE ANSCHLUSSKLEMMEN SIND NUR MIT ZUBEHÖR VERFÜGBAR IHREM
 DEZE AANSLUITKLEMEN ZIJN ALLEEN VOORZIEN BIJ TOEPASSING VAN HUN OPTIONELE

ALIMENTACION
 POWER SUPPLY
 ALIMENTATION ELECTRIQUE
 STROMZULEITUNG
 AANSLUITSPANNING
3N ~ 400V 50HZ + PE

VENTILADOR U. INTERIOR
 INDOOR UNIT FAN
 VENTILATEUR D'UNITE INTERIEUR
 LÜFTER INNENGERÄT
 BINNENUNIT VENTILATOR

ALARM

RESET

DAD

30 mA
 01

02

1 2 3 4 5 6 7 8 9 10 11 12 13 14 21 22 23 24 25 26 27 28 51 52 53 PE 60 61 62 63 64 65 66 67 68 69 70 71 75 76 82 83 84 85 86 87 88 89 90 91 92 93 94 95 96 110 111 PE

1/9 Lennox Refrac S.A. ESQUEMA ELECTRICO ELECTRIC DIAGRAM ANCK 128D-152D C50 42-33-444-309 23H 3N ~ 400V 50Hz + PE

3N~400V 50Hz + PE

N L1 L2 L3 PE

VER MANUAL INSTALACION
SEE INSTALLATION MANUAL (IOM)
VOIR LE MANUEL D'INSTALLATION
SIEHE INSTALLATIONSHANDBUCH (IOM)
ZIE INSTALLATION MANUAL (IOM)

FUSIBLES FUSES FUSIBLES SICHERUNGEN ZEKERINGEN	ANCK	
	128D-152D	128D 152D
F1(CM1)	3x40A	3x40A
F2(CM2)	3x25A	3x25A
F3(CM3)	3x40A	3x63A
F5(CFM1)	3x10A	3x10A
F6(CFM2)	3x10A	3x10A
F7(FM)	3x20A	3x20A

INTENSIDAD CURRENT INTENSITE STROM STROOM	ANCK 128D		ANCK 152D	
	I _m (MCC)	I _q (LRA)	I _m (MCC)	I _q (LRA)
400V 3~50Hz	CM1	29.8A	189A	189A
	CM2	20.7A	127A	127A
	CM3	29.8A	189A	48A
	CFM1	4A	14A	4A
	CFM2	2.4A	8.4A	4A
	FM	12A	72A	12A

FUSIBLES BATERIA ELEC. FUSES ELEC. HEATER FUSIBLES RESISTENCE ELEC. SICHERUNGEN E.-HEIZUNG ZEKRING ELECTRISCHE VERHITTLER	ANCK 128D-152D	
	30kW 1ST	40kW 1ST
400V 3~50Hz	F9(EH)	3x50A 3x63A

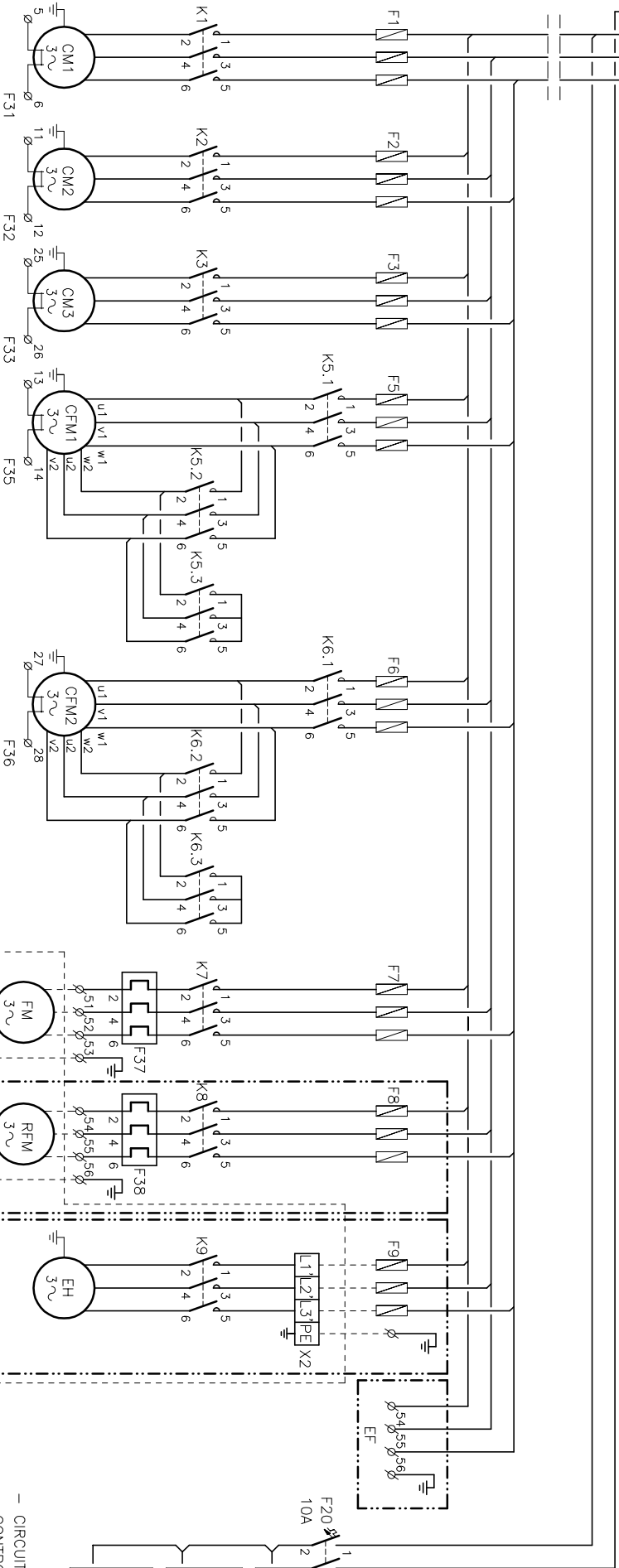
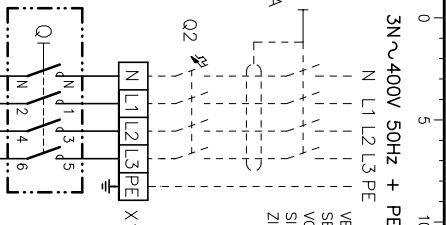

Elemento Opcional
Optional Element
Element optionel
Optionales bauteil

A realizar por el instalador
To wire by the installer
A câbler par l'installateur
Verdrahtung durch den installateur

2/9
Lennox Refrac S.A.

ESQUEMA ELECTRICO
ELECTRIC DIAGRAM

ANCK 128D-152D C50
4Z-33-444-309 23H
3N~400V 50Hz + PE

- CIRCUITO DE MANIOBRA
- CONTROL CIRCUIT
- CIRCUIT DE CONTROL
- STEUERKREIS
- REGELCIRCUIT

0 5 10 15 20 25 30 35 40 45 50 55 60 65 70 75 80 85 90 95

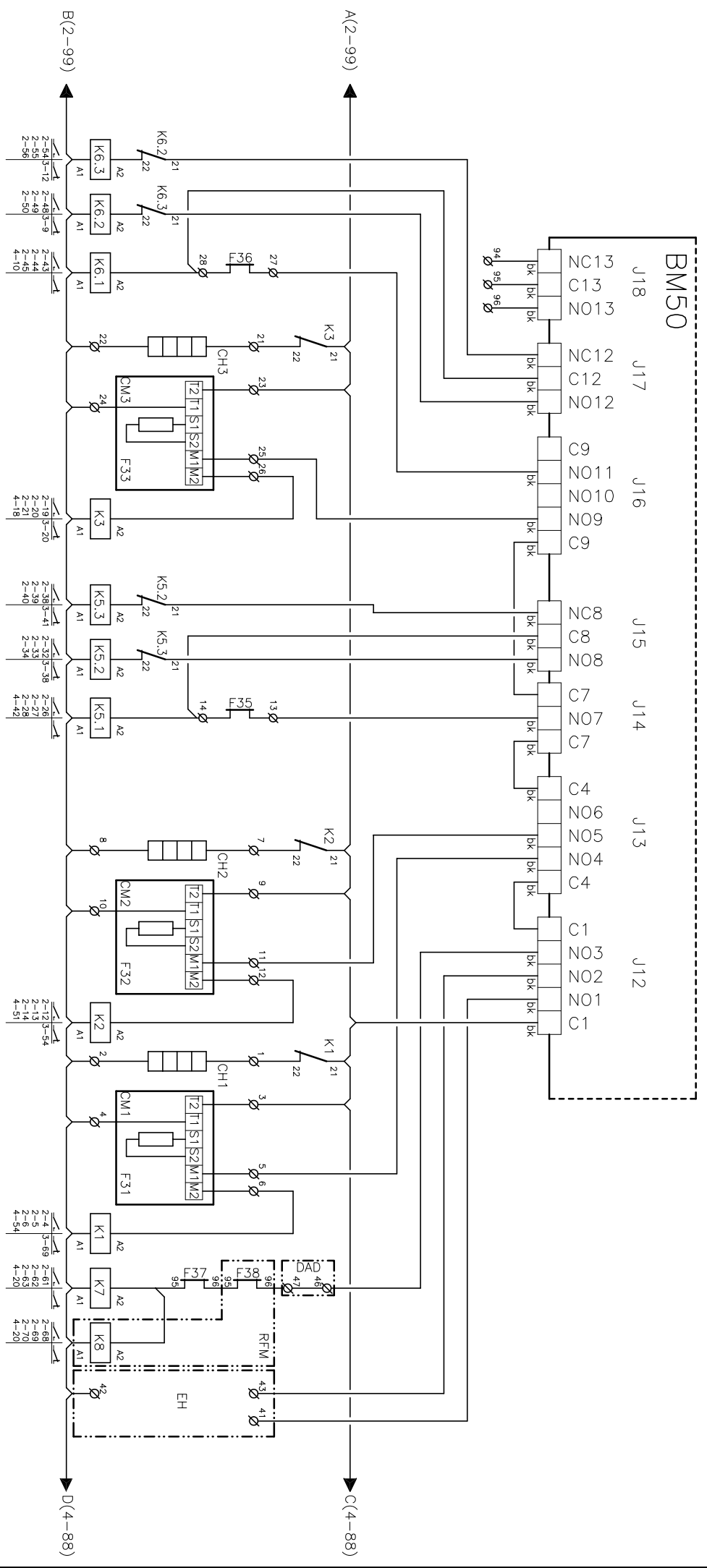

Elemento Opcional
 Optional Element
 Element optionnel
 Optionales bauteil

A realizar por el instalador
 To wire by the installer
 A câbler par l'installateur
 Verdrahtung durch den installateur

3/9	Lemnox Refrac S.A.	ESQUEMA ELECTRICO ELECTRIC DIAGRAM	ANCK 128D-152D C50	4Z-33-444-309 23H 3N~400V 50Hz + PE
------------	--------------------	---------------------------------------	---------------------------	--

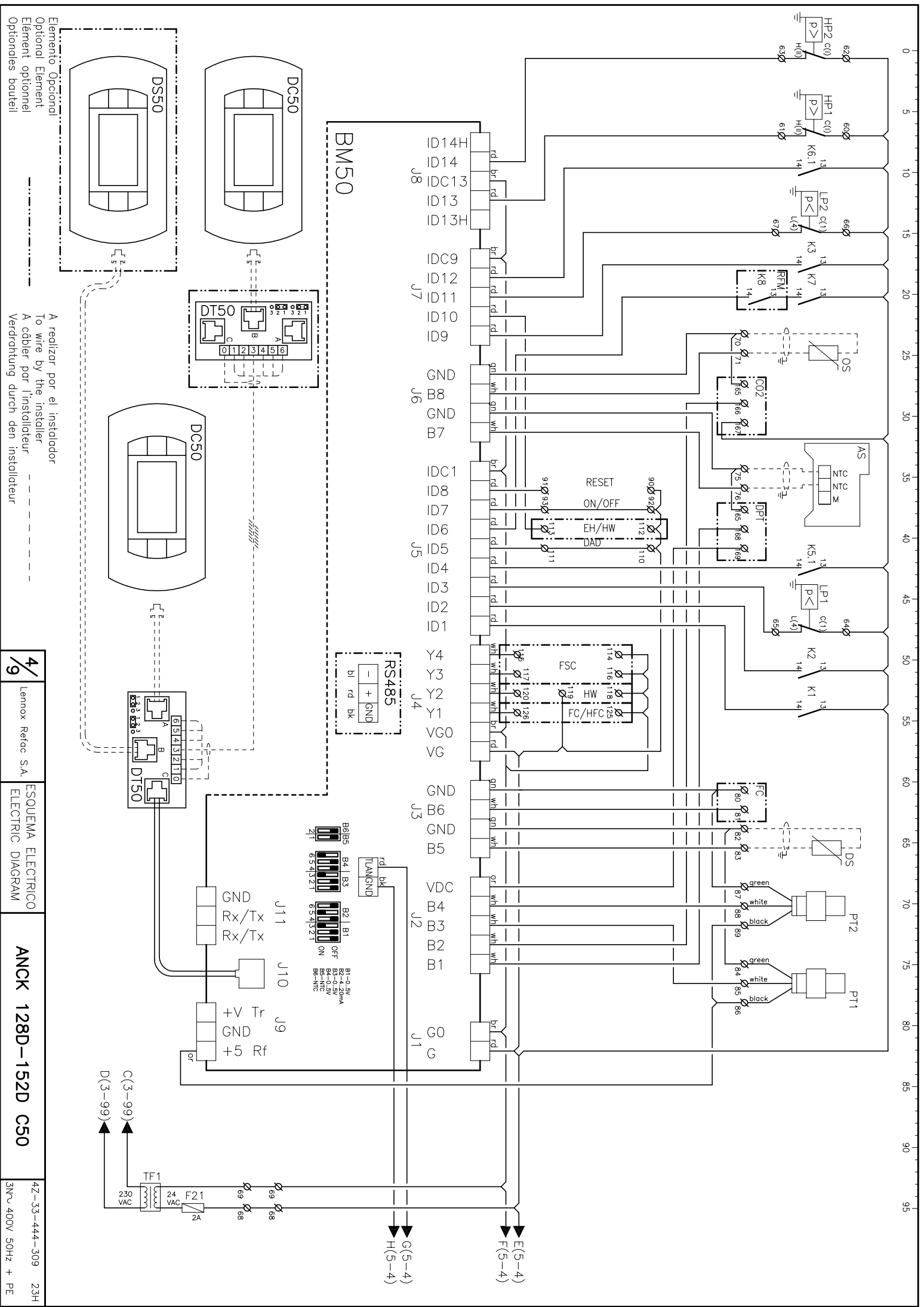

Elemento Opcional
 Optional Element
 Element optionnel
 Optionales bauteil

A realizar por el instalador
 To wire by the installer
 A câbler par l'installateur
 Verdrahtung durch den Installateur

4/9
 Lemnox Refrac S.A.

ESQUEMA ELECTRICO
 ELECTRIC DIAGRAM

ANCK 128D-152D C50

4Z-33-444-309 23H
 3N~400V 50Hz + PE

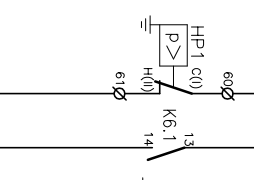
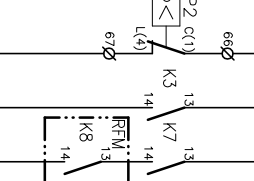
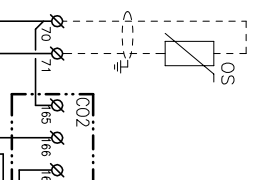
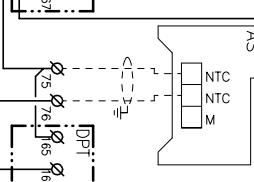
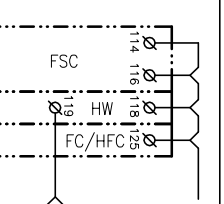
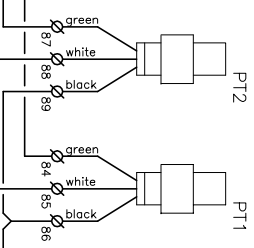
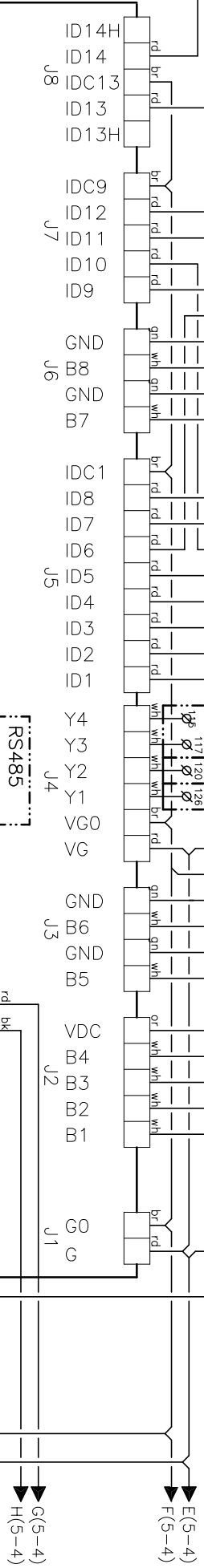
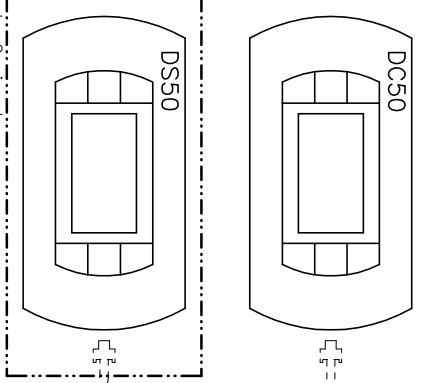
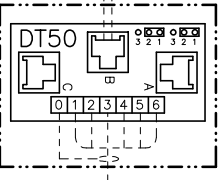
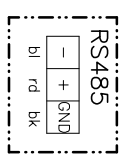
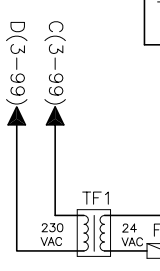

0 5 10 15 20 25 30 35 40 45 50 55 60 65 70 75 80 85 90 95

0 5 10 15 20 25 30 35 40 45 50 55 60 65 70 75 80 85 90 95

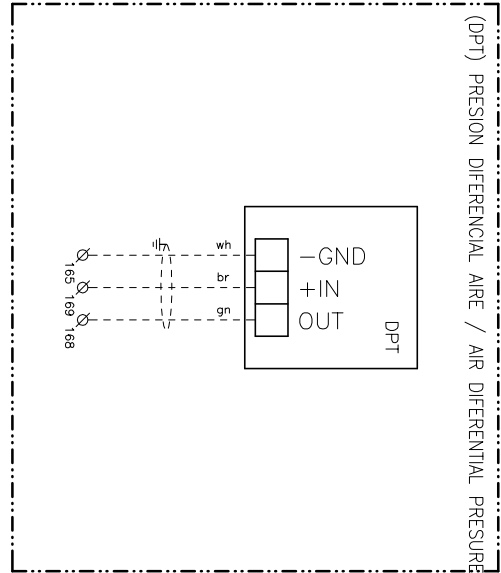
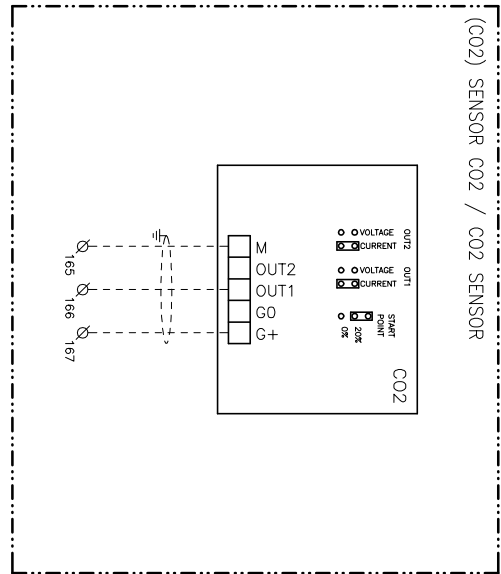
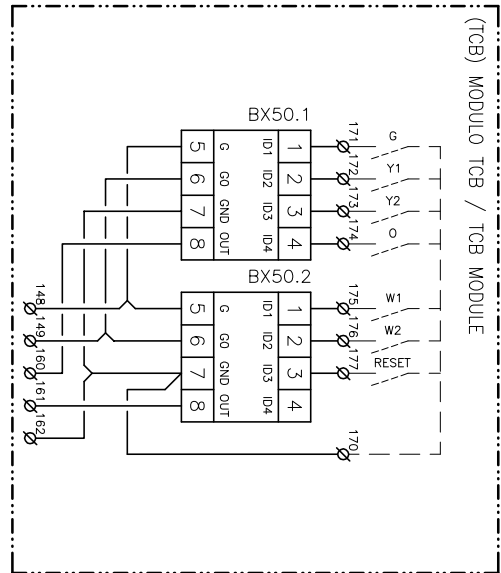

(BE50) MODULO EXPANSION / EXPANSION MODULE

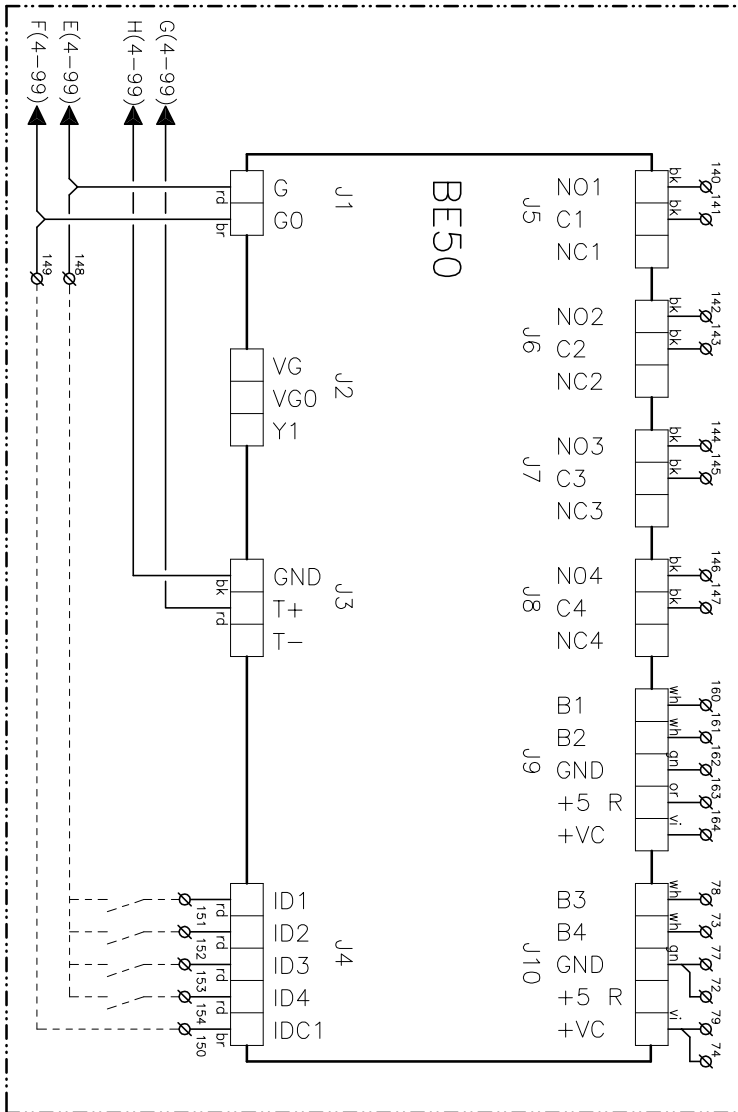

(RS) SONDIA RETORNO / RETURN SENSOR

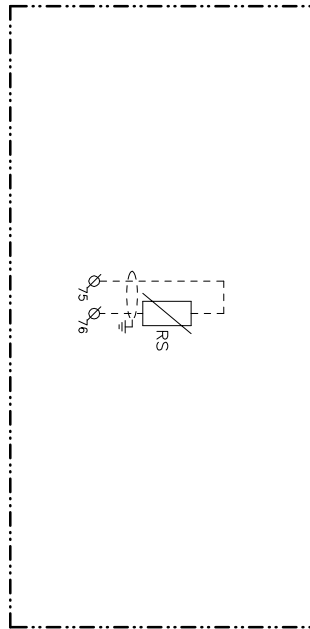

(HFC) FREECOOLING ENTALPICO/ENTHALPIC FREECOOLING

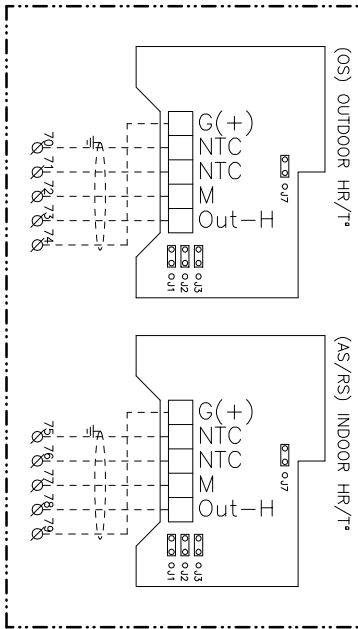

Elemento Opcional
 Optional Element
 Element optionel
 Opcionales bauteil

A realizar por el instalador
 To wire by the installer
 A coblar por l'instalador
 Verdrahtung durch den installateur

5/9

Lennox Refrac S.A.

ESQUEMA ELECTRICO
 ELECTRIC DIAGRAM

ANCK 128D-152D C50

4Z-33-444-309 23H
 3N~400V 50Hz + PE

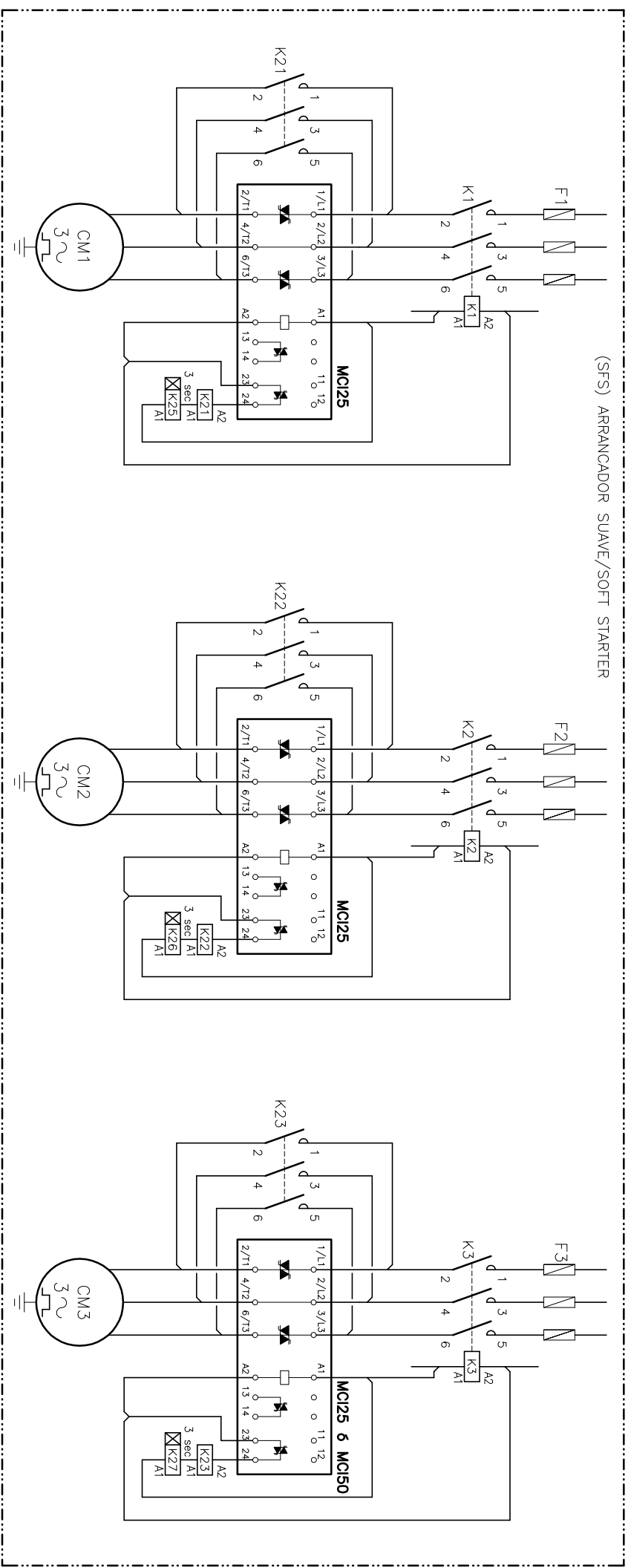
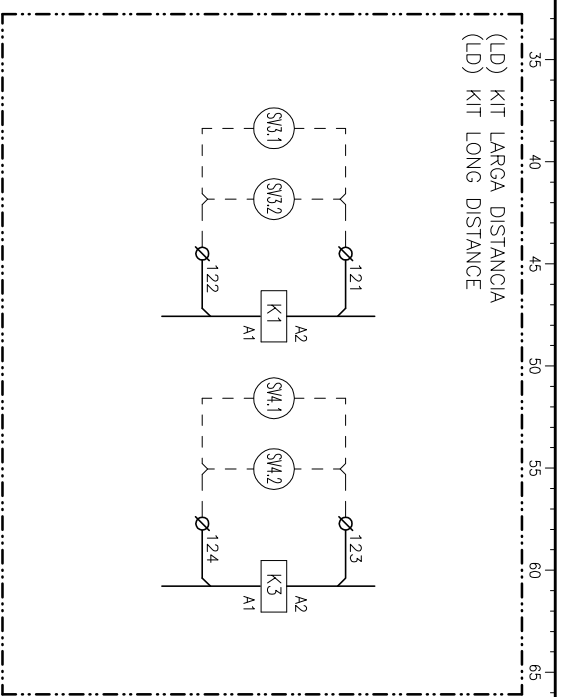
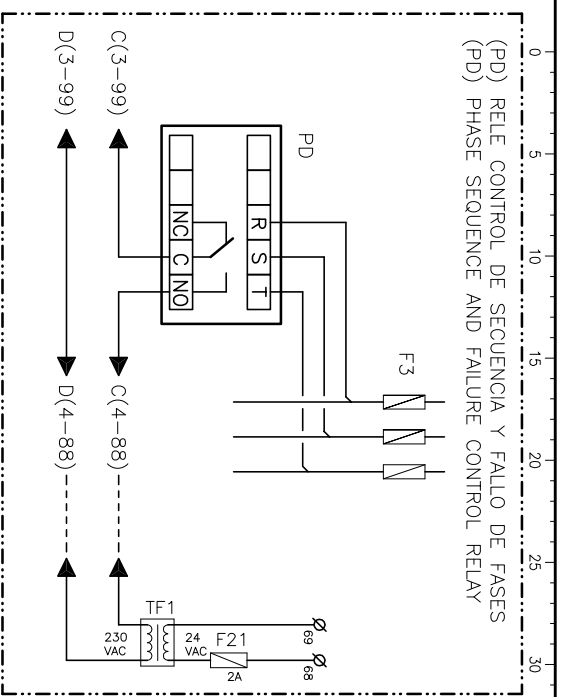

Elemento Opcional
 Optional Element
 Element optionel
 Opcionales bauteil

A realizar por el instalador
 To wire by the installer
 A cobler por l'installateur
 Verdringung durch den installateur

6/9

Lennox Refrac S.A.

ESQUEMA ELECTRICO
 ELECTRIC DIAGRAM

ANCK 128D-152D C50

4Z-33-444-309 23H
 3N~400V 50Hz + PE

(FSC) CONTROL DE CONDENSACION / FAN SPEED CONTROL

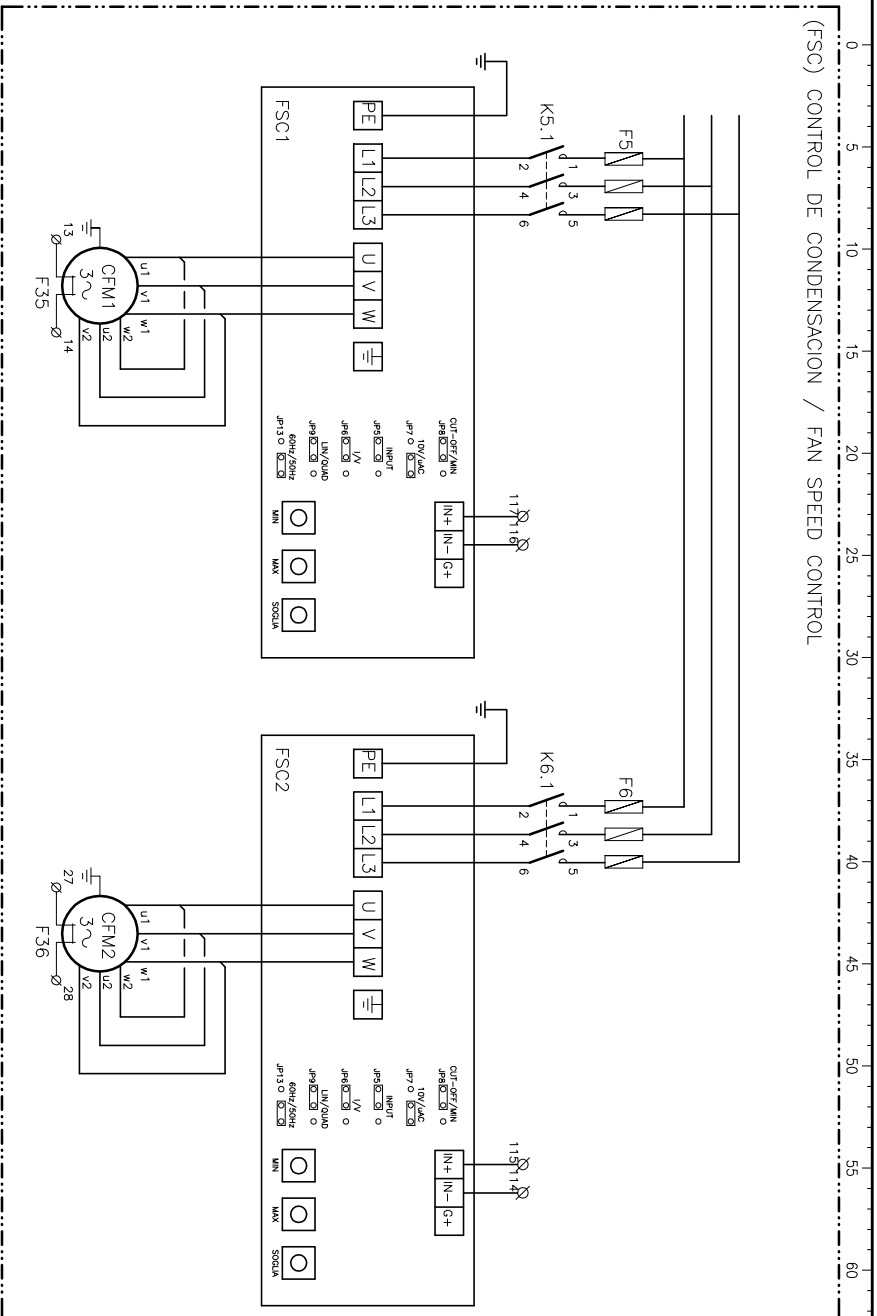

(HW) BAT. AGUA CALIENTE / HOT WATER COIL

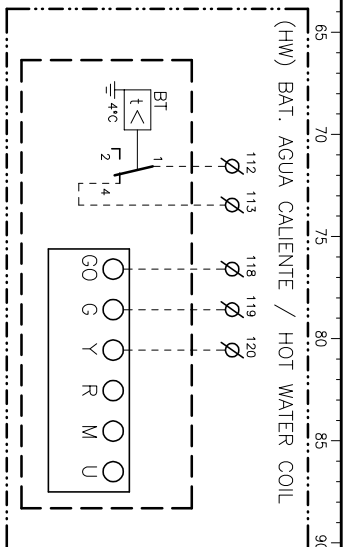

(EH) BATERIA ELECTRICA / ELECTRICAL HEATER

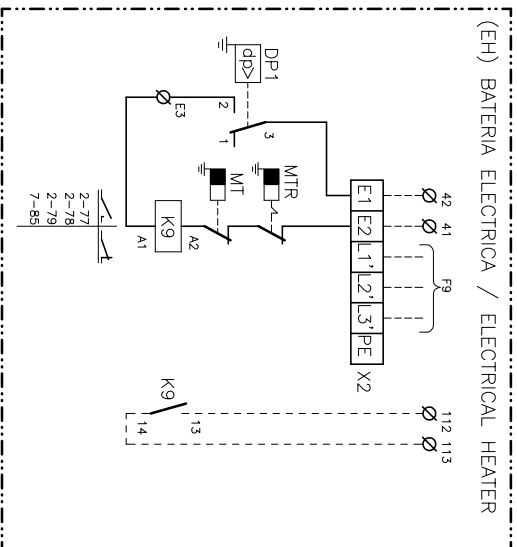

(HFC / FC) FREECOOLING / FREECOOLING

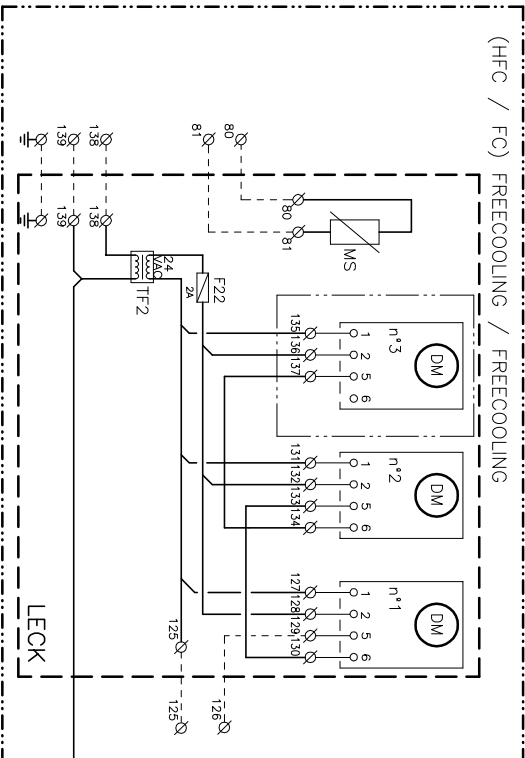

(EF) VENTILADOR EXTRACCION / EXTRACT FAN

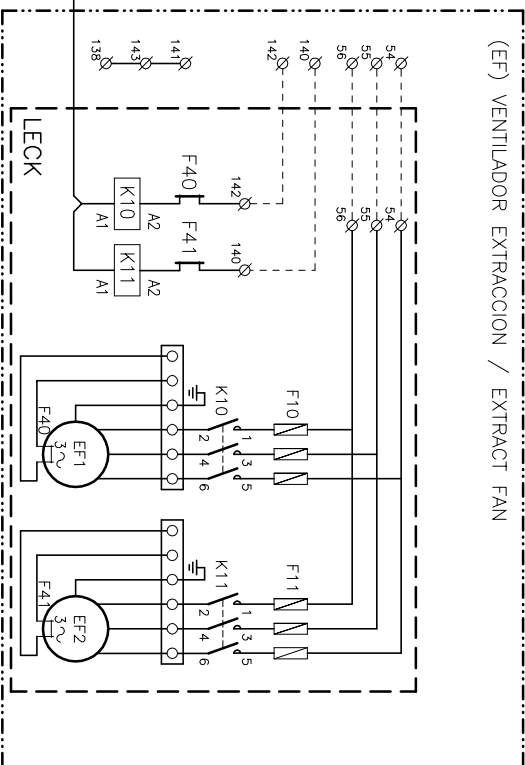

Elemento Opcional
 Optional Element
 Element optionnel
 Opcionales bauteil

A realizar por el instalador
 To wire by the installer
 A cobler par l'installateur
 Verdrahtung durch den installateur

7/9
 Lennox Refrac S.A.
 ESQUEMA ELECTRICO
 ELECTRIC DIAGRAM

ANCK 128D-152D C50

4Z-33-444-309 23H
 3N~400V 50Hz + PE

