

HMC Micro Cooler - Product Presentation

HMC - Compact Close Control Units

- DX version Down Flow
- DX version Displacement
- DX + Direct Free cooling

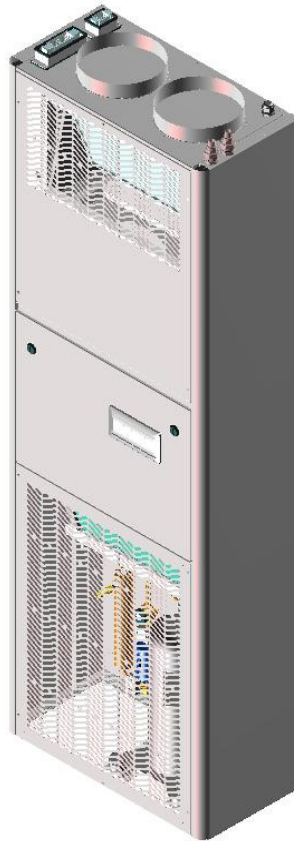

Products Description

The micro coolers CCAC was developed according "DNP_P_04_02 rev00" MKTG specification to compete against other manufacturer's cabinet cooler products and to satisfy specific market needs.

This units could be supplied only in DX version, down flow or displacement, frontal and side installation as shown in the following simplified drawings,

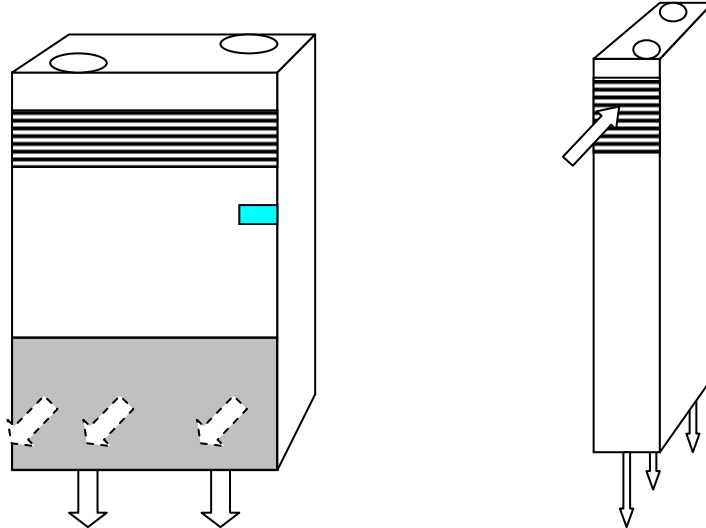

In the upper part of the HMC units can be installed a free cooling damper to allow the direct free cooling operation : in this case the fresh air will be ducted to the unit by means of flexible D=200mm ducts connected to the two (2) spigots on the top of the unit .

Micro Coolers cover a range between 4.0 => 6.9 kW and have common design philosophy :

1. Compact dimension L x D x H 600 x 300 x 1800 mm
2. Suction from the front (+ from the top for direct free Cooling version)
3. Backward curved blades fans (plug fans) complete with adjustable speed (170-190 Volts @ 20 Pa AESP)
4. Evaporating coil positioned after the fans
5. Hydrophilic treatment on the fins
6. Thermostatic valve with MOP function (EEV as an option)
7. Refrigerant connections from the top right side. Refrigerant shut off valves in the compressor compartment.
8. Electrical connections with IP 65 connectors from the top left side
9. Copeland Scroll compressors for sizes 045, 056, 070
10. Daewoo Carrier Rotary Compressor for size 035
11. Single phase power supply

1. **Electrical panel.** It is located in the middle of the unit and its door supports the LCD display.

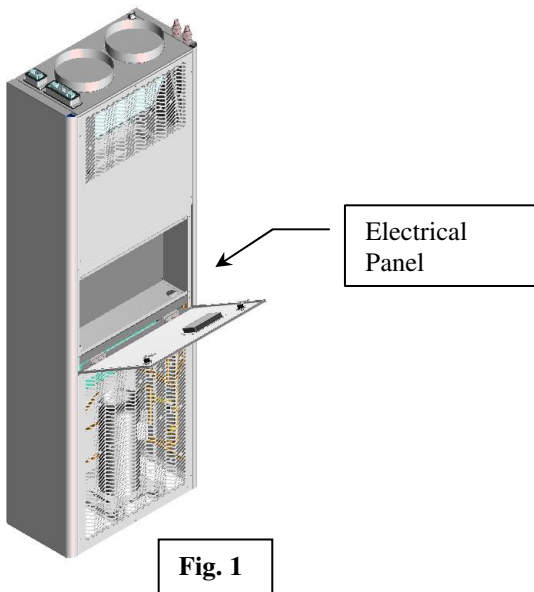

2. **Electrical Connections.** All connections are from the top by means of IP 65 plugs as shown in fig. 2.



The male connectors are fixed on the unit; the female have to be removed and wired according the electrical drawing HF62000240 page 13.

- The small 6 poles connector "C1" on the left back side is for unit's power supply,
- The big 24 poles connector "C2" on the left side is for signals/alarms : the number of available signals depends on the configuration of the units (alarm board Yes / alarm board Not)
- The small 6 poles connector "C3" on the right side (not fixed on the unit's frame) is for the remote condenser.

3. **Refrigerant Connections.** The connections are located on the top right side (fig.2) and are provided with rotalock adaptors. The refrigerant shut off valves are located into compressor compartment as shown in fig 3 for scrolls and fig 4 for rotary compressor (model HMC 035)

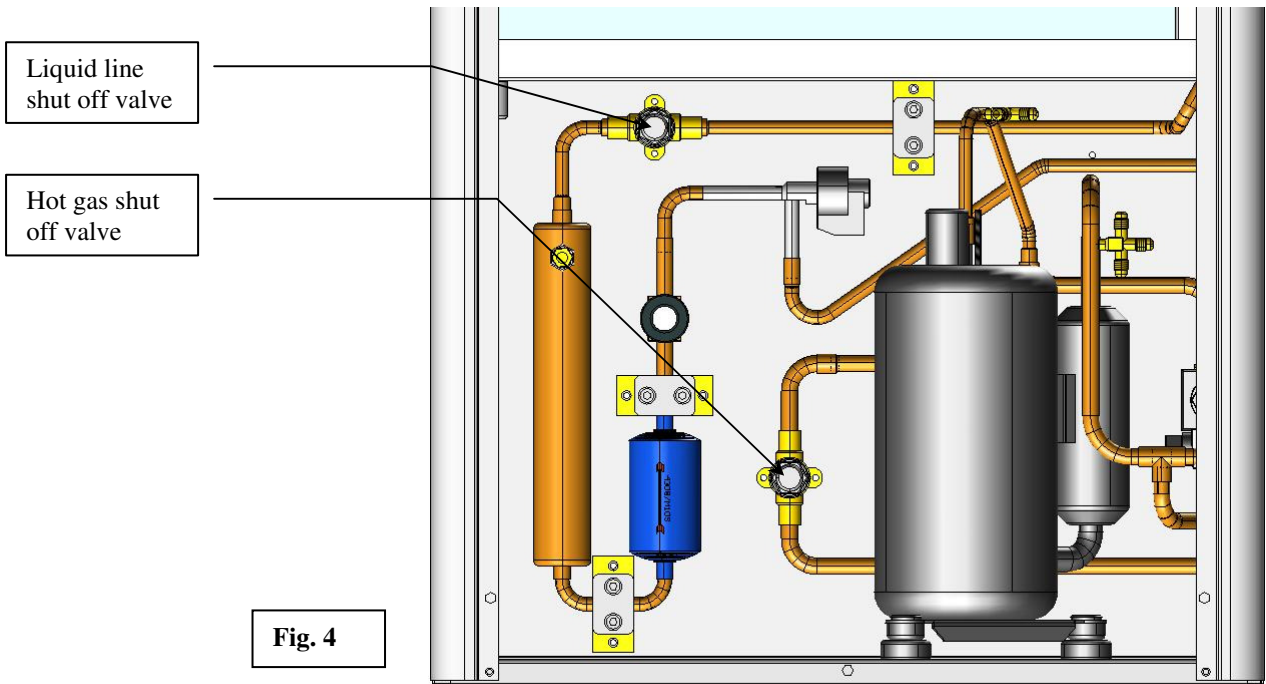
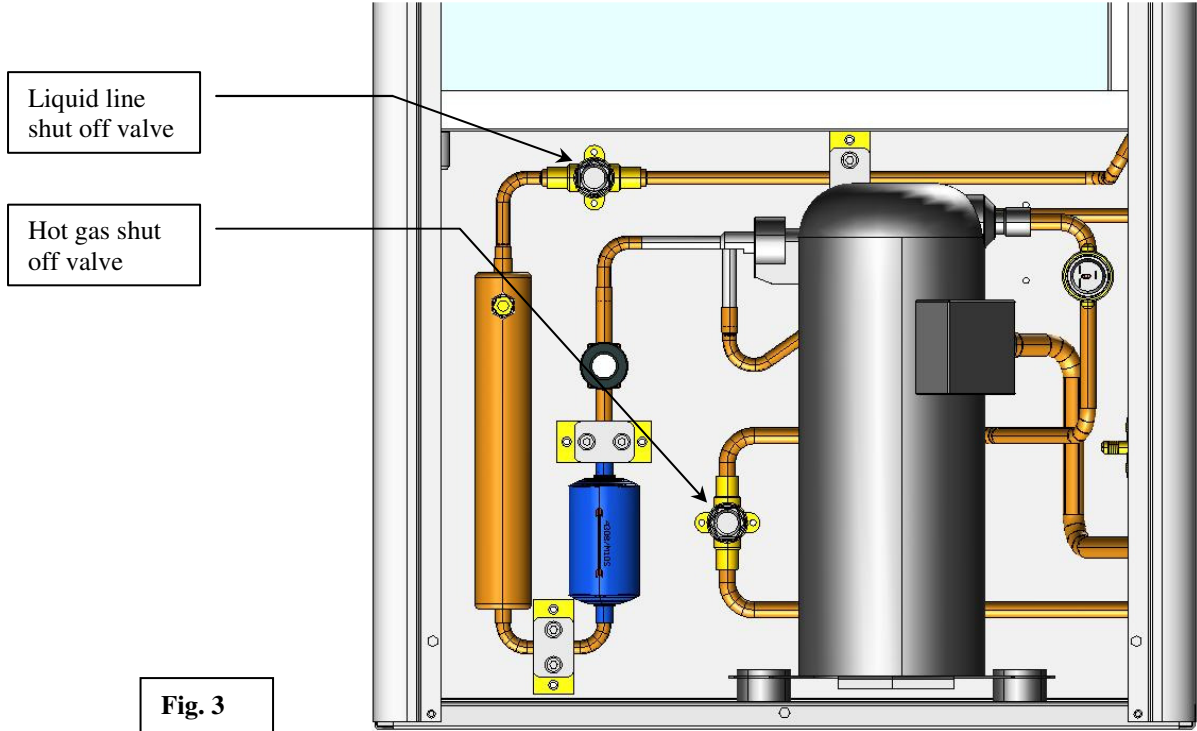

4. **Electronic expansion valve.** The valve is located into compressor compartment as shown in fig. 5, and it is fixed on the back side of the compartment

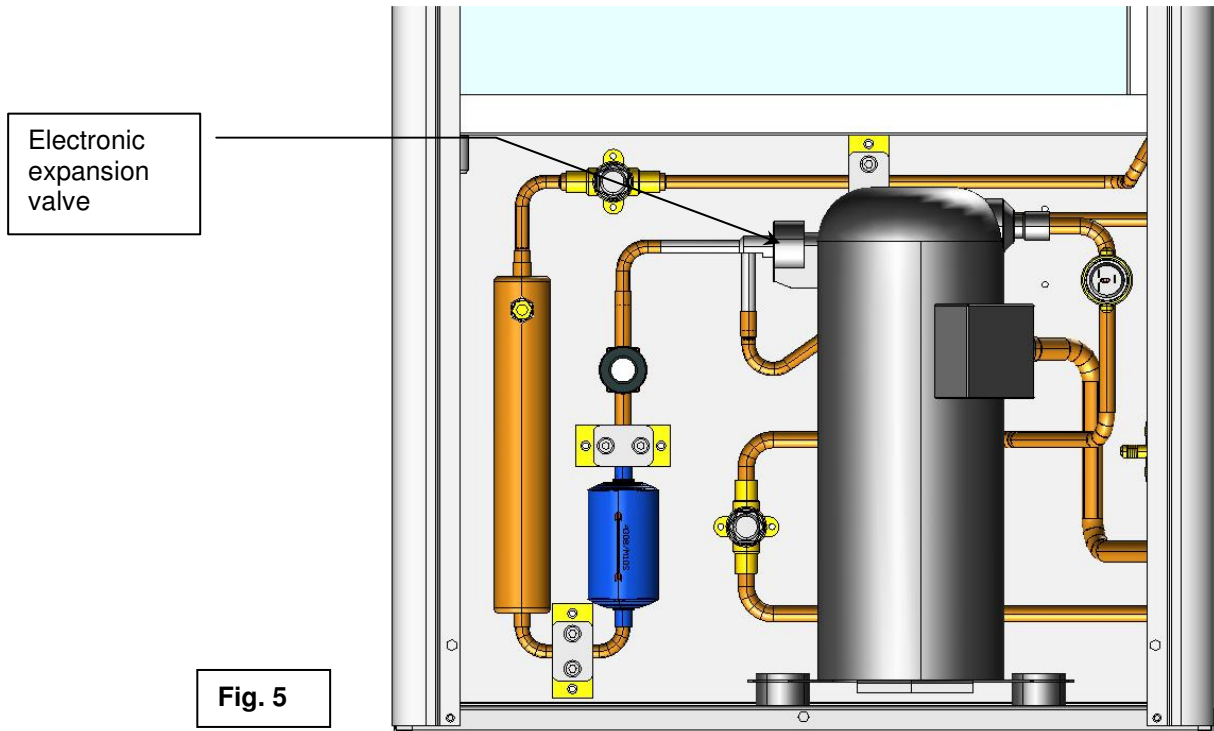

5. **Solenoid valve for start up operation.** This component is only present in the smallest unit HMC 035 equipped with rotary compressor: this kind of compressor doesn't allow the pressures equalisation during the stop phase and the single phase e-motor doesn't have a big starting torque. For this reason a solenoid valve between discharge and suction pipes is present: this valve opens when the compressor is switched off to allow the pressure equalisation and, at the same time, the check valve on the discharge line avoids back flow from the condenser. [fig.6]

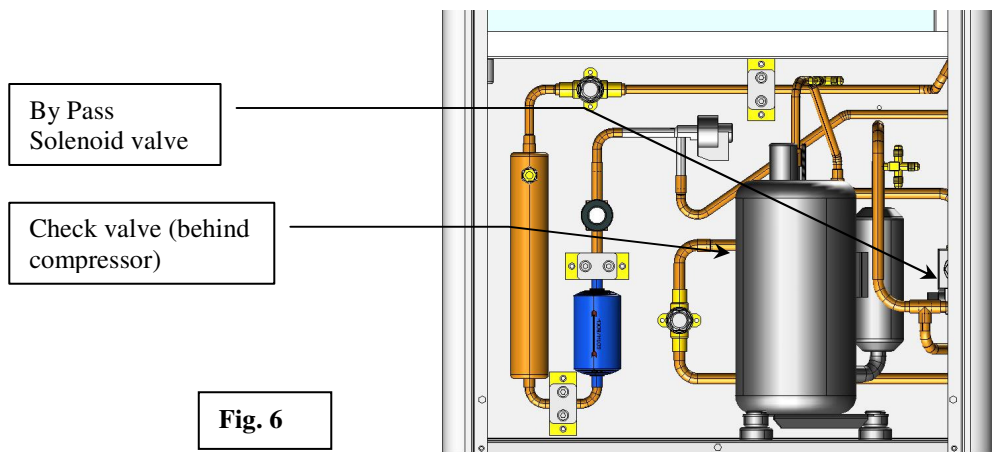

6. **Air filters.** For remove the filter, open the upper panel and simply extract the filter as shown in fig. 7. The position and the overall dimensions are the same for G4 and F6 filters.

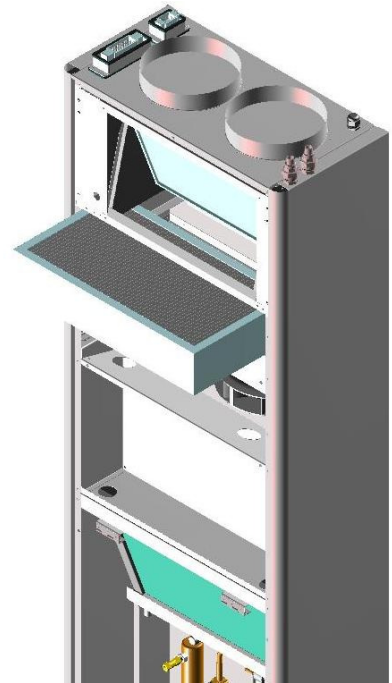

Fig. 7

7. **Fans.** The adopted fans are of the backward curved blades (Plug) type made from EBM Germany. This components are equipped with an external rotor motor for the maximum efficiency and reliability and reduced sound emissions, even in fan speed modulation. For remove the fans, firstly remove the fan nozzles (accessible from the filter compartment), remove the two screws of the fan support, turn it up and extract the support with both fans (fig. 8).

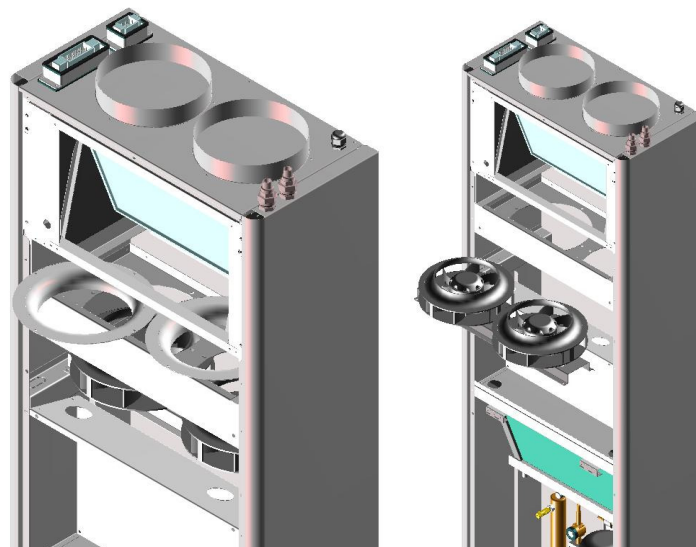

Fig. 8

Technical data

		HMC 070	HMC 056	HMC 045	HMC 035
Power supply	[V/Ph/Hz]	230/ 1 /50	230/ 1 /50	230/ 1 /50	230/ 1 /50
Air Flow @20 Pa AESP	[m3/h]	1350	1230	1230	1050
Frame					
H	[mm]	1800	1800	1800	1800
L	[mm]	600	600	600	600
P	[mm]	300	300	300	300
Weight	[kg]	147	139	131	129
Compressor					
Type		Scroll	Scroll	Scroll	Rotary
Cooling Capacity @ 27°C 40% UR – external air temp. 35°C	[kW]	6.90	5.75	4.66	4.08
SHR	[-]	0.91	0.96	0.98	1
Power consumption	[kW]	1.97	1.51	1.23	1.05
Nominal Absorbed Current	[A]	9.2	7.1	5.6	4.5
FLA	[A]	14.8	11.4	10	8.8
LRA	[A]	61	47	35	28
POE Oil charge	[l]	1	1	0.74	0.74
Finned coil evaporator					
Front Surface	[m2]	0.17	0.17	0.17	0.17
Geometry		25 x 21,65	25 x 21,65	25 x 21,65	25 x 21,65
Rows	[-]	4	4	3	3
Type of fins	[-]	Hydrophilic	Hydrophilic	Hydrophilic	Hydrophilic
TFT (Total Free Cooling Temperature)	[°C]	11.7	13.1	15.6	15.4
Fin pitch	[mm]	1.8	1.8	1.8	1.8
Indoor fan					
Type		Plug	Plug	Plug	Plug
Number of fans		2	2	2	2
Fans absorbed current @20 Pa AESP	[A]	1.1	0.93	0.93	0.82
Fans absorbed power @20 Pa AESP	[W]	240	210	210	185
Air Filter STD					
Filtration		G4	G4	G4	G4
Overall surface	[m2]	2.8	2.8	2.8	2.8
Electrical heaters					
Total Heating Capacity		1.6	1.6	1.6	1.6
N° of heaters	[kW]	1	1	1	1
Material	[-]	Aluminium	Aluminium	Aluminium	Aluminium
Sound Data (*)					
Sound power level (with F6 filter)	[dB(A)]	57	56	56	54
Sound pressure level** (with F6 filter)	[dB(A)]	43	42	42	40
Sound power level (with G4 filter)	[dB(A)]	55	54	54	52
Sound pressure level** (with G4 filter)	[dB(A)]	41	40	40	38
Refrigerant Connections		Rotalock 1/2" + 1m metallic flexible pipes	Rotalock 1/2" + 1m metallic flexible pipes	Rotalock 1/2" + 1m metallic flexible pipes	Rotalock 1/2" + 1m metallic flexible pipes
Refrigerant connection position		Top of the unit	Top of the unit	Top of the unit	Top of the unit

** At 1,5 meters height, 2 meters frontal distance in free field – downflow version (20 Pa AESP)

* With F6 filter the fan's speed have to be increased => increasing in sound emissions



Accessories

	HMC
Electrical heaters	○
HP Fans	•
Advanced μP with LCD Display	•
Electronic Expansion Valve	○
Air flow switch	•
Dirty filters switch	•
F6 filter	○
Smoke & fire sensor	○
Adjustable base frame 100-400 mm	○
Insulating materials according german B1 classification	•
Plug connectors IP65	•
Emergency cooling 48Vcc (with free cooling option)	○
Flexible connection refrigerant side (metallic pipes) L=1000mm	○
Flexible connection air side L=3000mm D=200mm	○
Modulating damper for direct free cooling	○

Air flows configuration

	Discharge ▶	Down	Front	Top	Rear
Suction from ▼					
Down		N.A.	N.A.	N.A.	N.A.
Front		•	Displacement	N.A.	N.A.
Top		•	Displacement	N.A.	On request
Rear		N.A.	N.A.	N.A.	N.A.