



Serie	HTG
Model	035 - 056

Drawing code	HF620C0812	Controller	PC03
--------------	------------	------------	------

Power supply	230V/1~/50Hz + N	-
Auxiliary supply	24 VAC	-

Created by	N.C.1	Revision by	-	Index	-
Date	18/03/2008	On	-		

Max power (kW)	SEE TABLE ON PAGE 2
FLA (A)	SEE TABLE ON PAGE 2
RLA (A)	SEE TABLE ON PAGE 2

Main protection	SEE TABLE ON PAGE 2
-----------------	---------------------

1	2		3	4	5	6		7		8	
MODEL	POWER SUPPLY	MAX ABSORBED POWER (kW)	MAX ABSORBED CURENT (A)	RLA (A)	MAIN SUGGEST PROTECTION gG FUSE TYPE	MIN SUGGEST CROSS SECTION LINE (mm ²) VS MAX LENGTH (m) AIR TEMPERATURE 30°C – MULTICORE CABLE – CABLE INSIDE TUBE ON AIR					
						PVC ISULATED		EPR (G7-G10) ISULATED			
						CABLE WORKING TEMPERATURE 70°C	MAX LENGTH VOLTAGE DROP<4%	CABLE WORKING TEMPERATURE 90°C	MAX LENGTH VOLTAGE DROP<4%		
035	LINE	1,6	10	35	16	1,5	37,9	1,5	37,9		
045	LINE	2,1	13,8	40	25	1,5	27,4	1,5	27,4		
056	LINE	2,8	21	80	32	4	47,6	2,5	29,8		
REV.	MODIFICATIONS	DATE	SIGN.	DATE	18/03/2008			HF620C0812		SHEET 2 OF 20	
				CHECK	F.F.1					CONTINUE	3
				APPR.	M.M.						

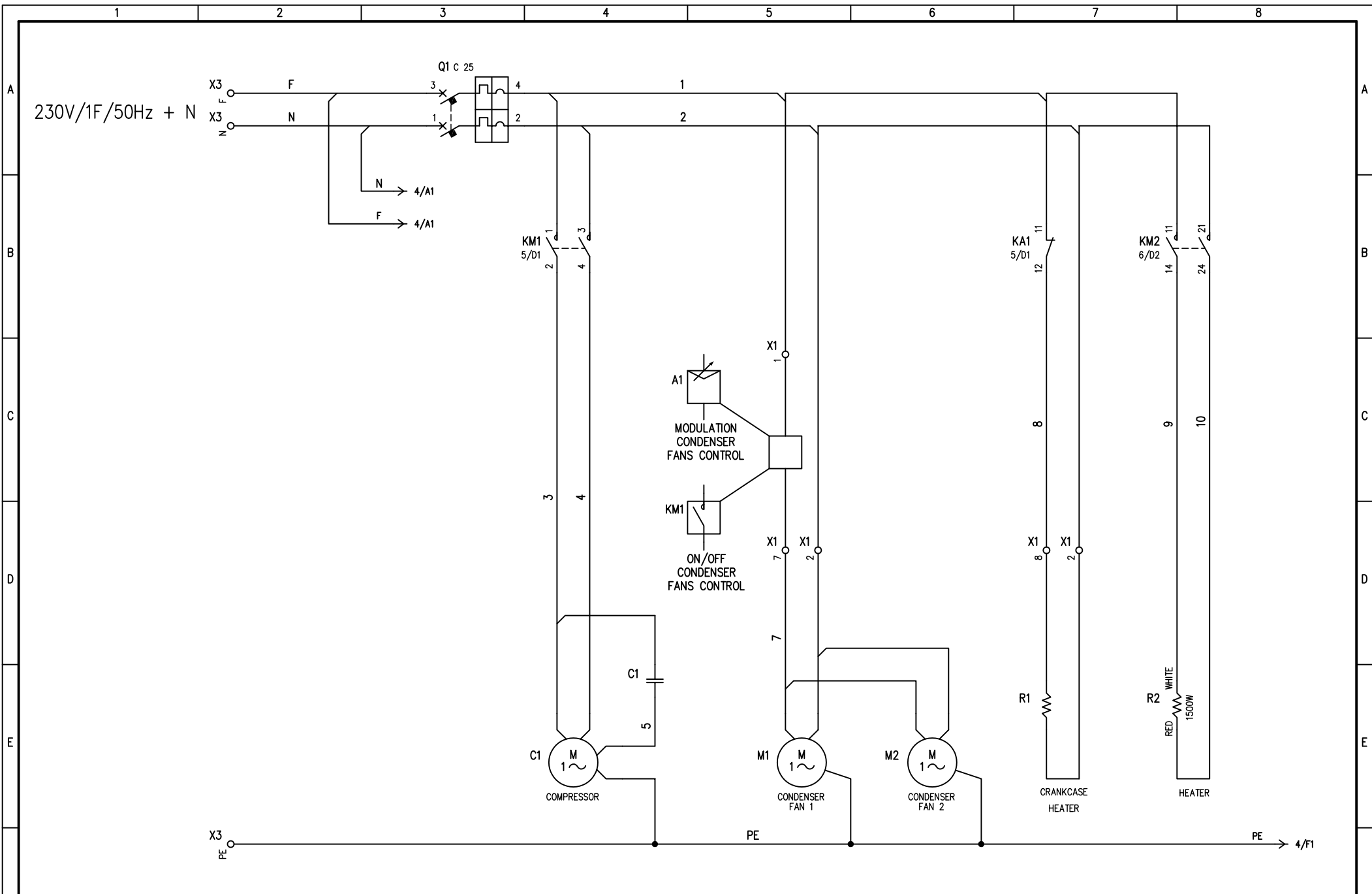

				DATE 18/03/2008					
				DRAW. N.C.1		HF620C0812		SHEET 3 OF 20 CONTINUE 4	
				CHECK F.F.1					
REV.	MODIFICATIONS	DATE	SIGN.	APPR. M.M.					
1		2		3	4	5	6	7	8

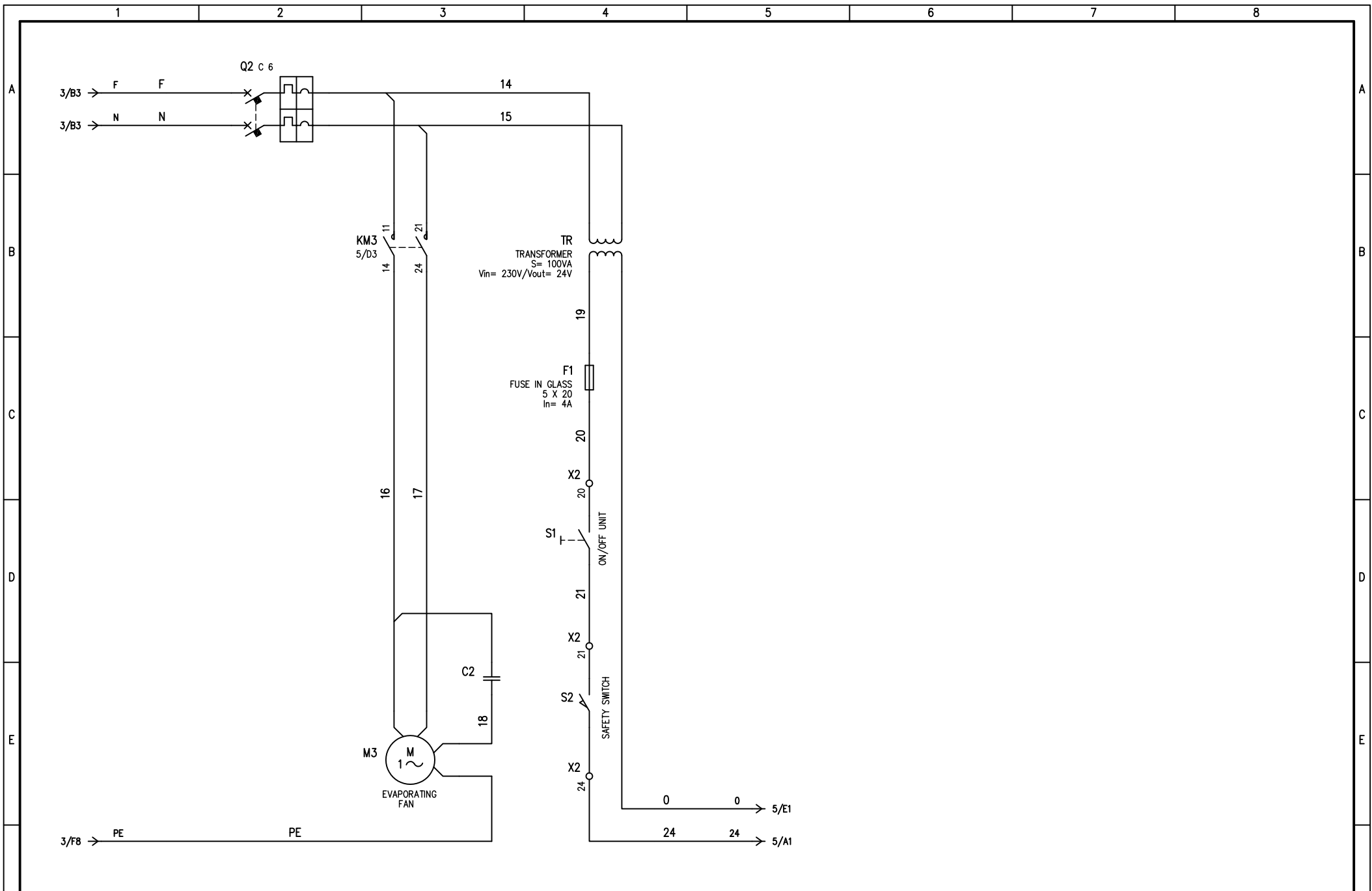

DATE 18/03/2008
 DRAW. N.C.1
 CHECK F.F.1
 APPR. M.M.



HF620C0812

SHEET 4 OF 20
 CONTINUE 5

REV.	MODIFICATIONS	DATE	SIGN.
1		2	3

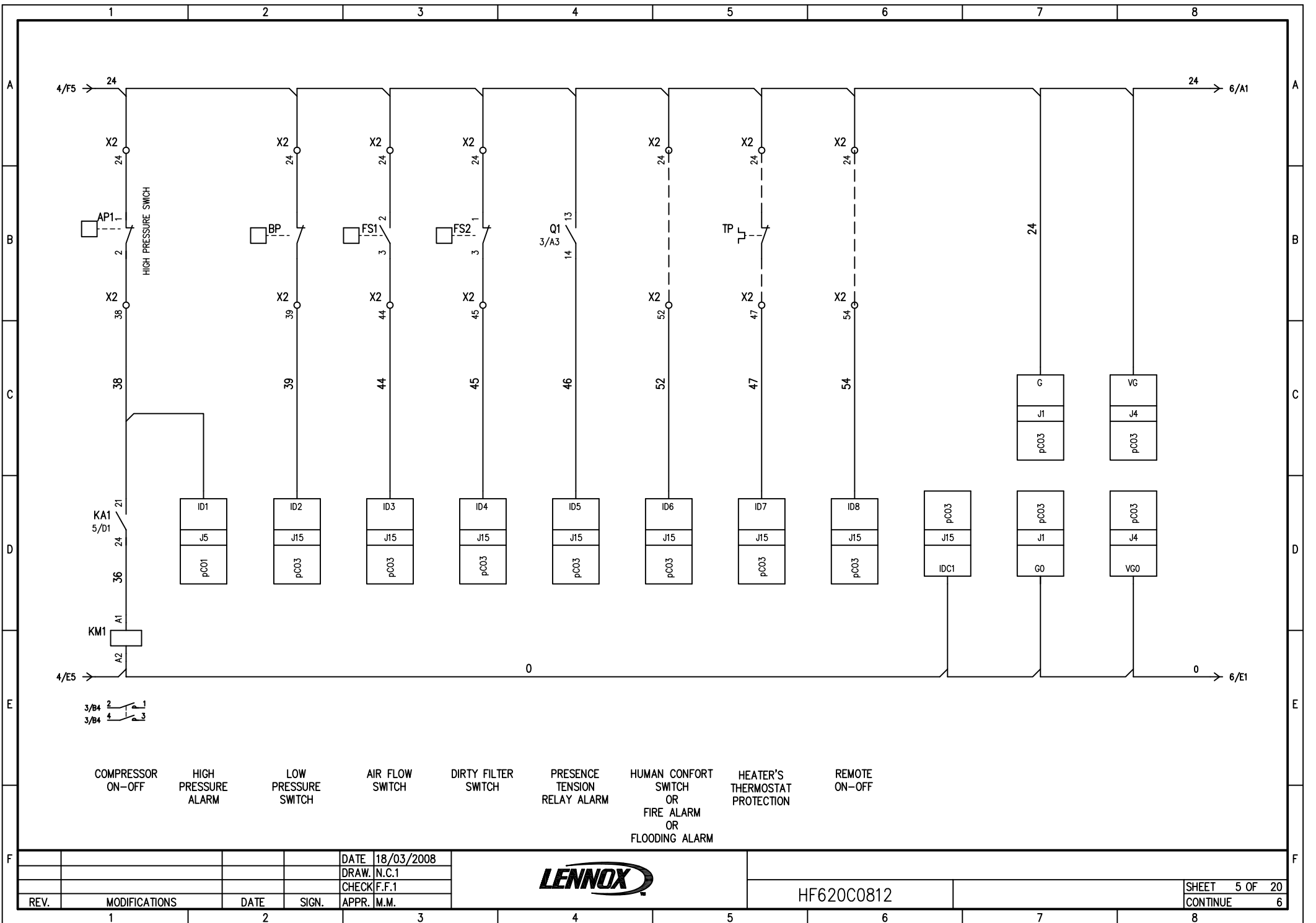

COMPRESSOR ON-OFF

HIGH PRESSURE ALARM

LOW PRESSURE SWITCH

AIR FLOW SWITCH

DIRTY FILTER SWITCH

PRESENCE TENSION RELAY ALARM

HUMAN CONFORT SWITCH OR FIRE ALARM OR FLOODING ALARM

HEATER'S THERMOSTAT PROTECTION

REMOTE ON-OFF

DATE 18/03/2008
 DRAW. N.C.1
 CHECK F.F.1
 APPR. M.M.



HF620C0812

SHEET 5 OF 20
 CONTINUE 6

REV.	MODIFICATIONS	DATE	SIGN.

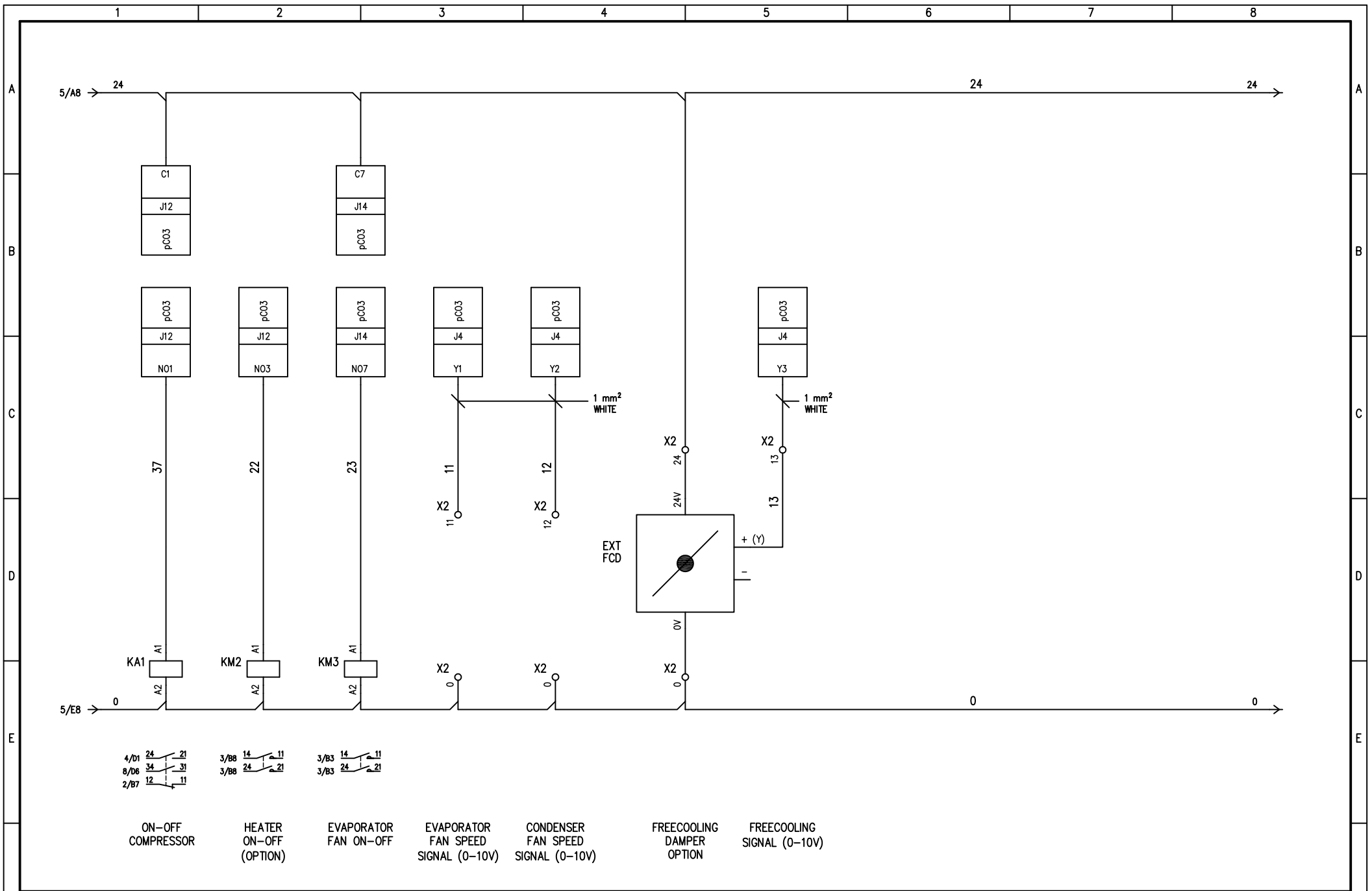

				DATE 18/03/2008				HF620C0812		SHEET 6 OF 20	
				DRAW. N.C.1						CONTINUE 7	
				CHECK F.F.1							
REV.	MODIFICATIONS	DATE	SIGN.	APPR. M.M.							
1		2		3	4	5	6	7	8		

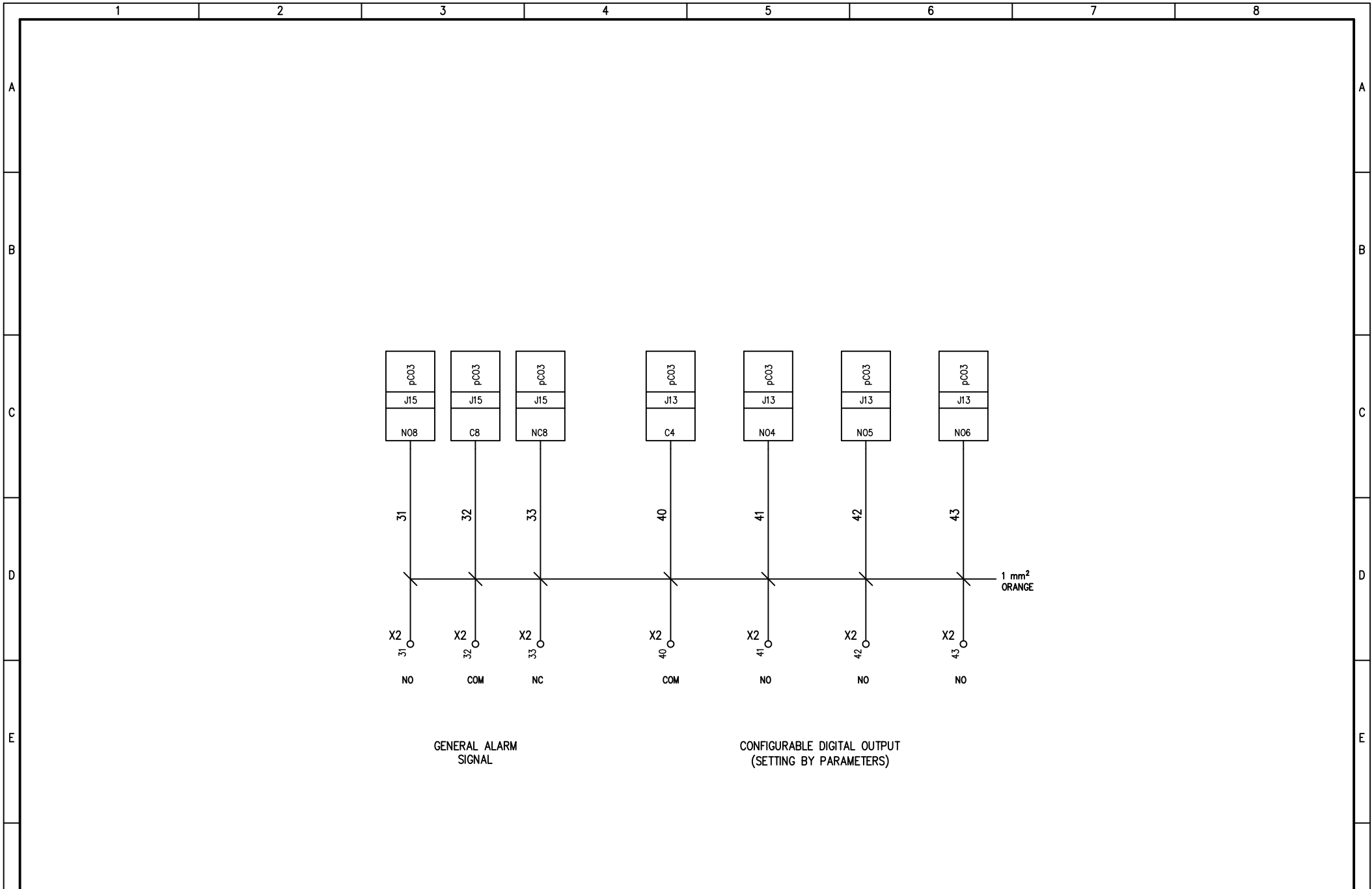

GENERAL ALARM
SIGNAL

CONFIGURABLE DIGITAL OUTPUT
(SETTING BY PARAMETERS)

				DATE 18/03/2008					
				DRAW. N.C.1					
				CHECK F.F.1					
REV.	MODIFICATIONS	DATE	SIGN.	APPR. M.M.	HF620C0812			SHEET 7 OF 20 CONTINUE 8	
1		2		3	4	5	6	7	8

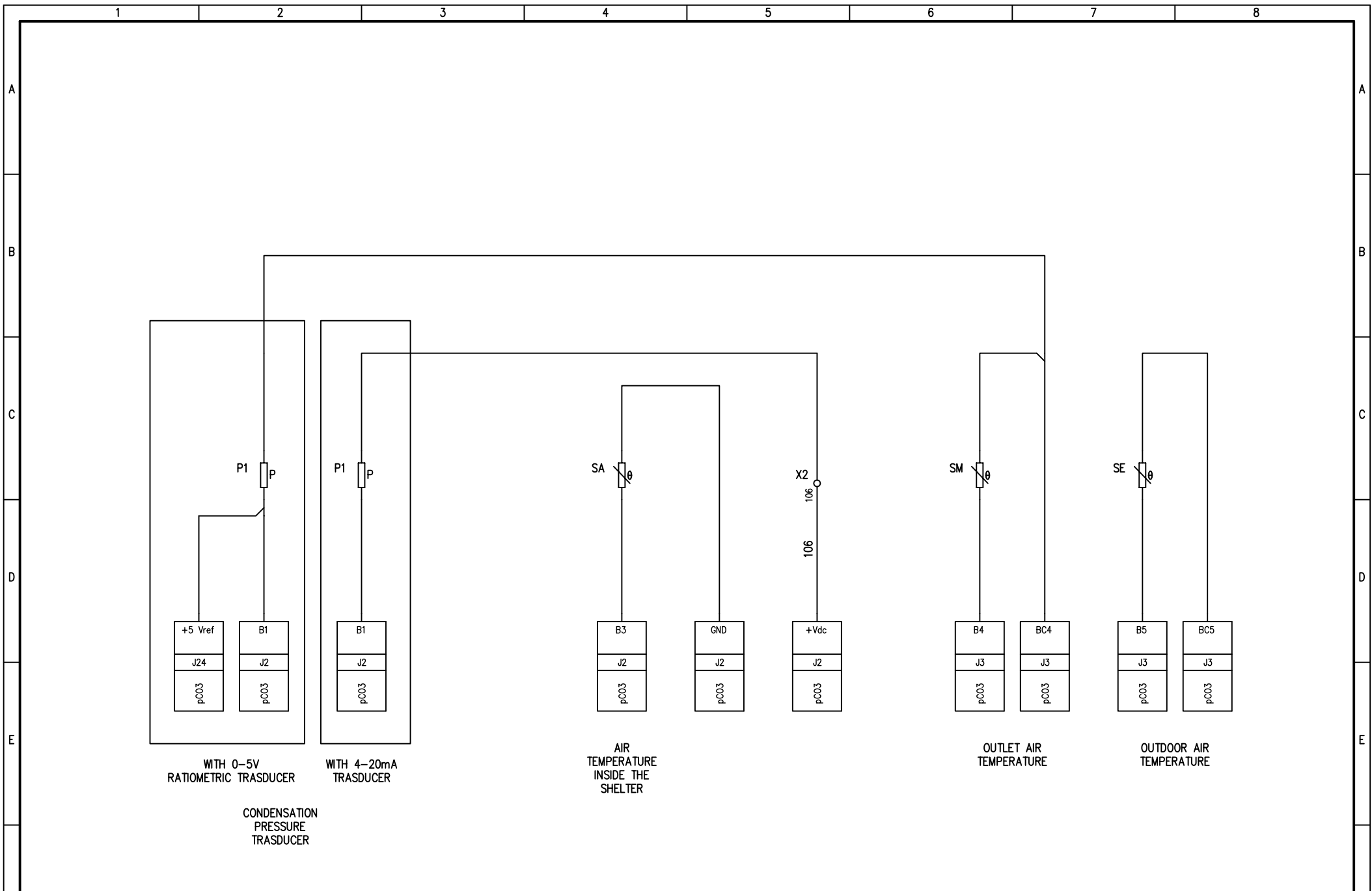

REV.	MODIFICATIONS	DATE	SIGN.	DATE 18/03/2008
				DRAW. N.C.1
				CHECK F.F.1
				APPR. M.M.



HF620C0812

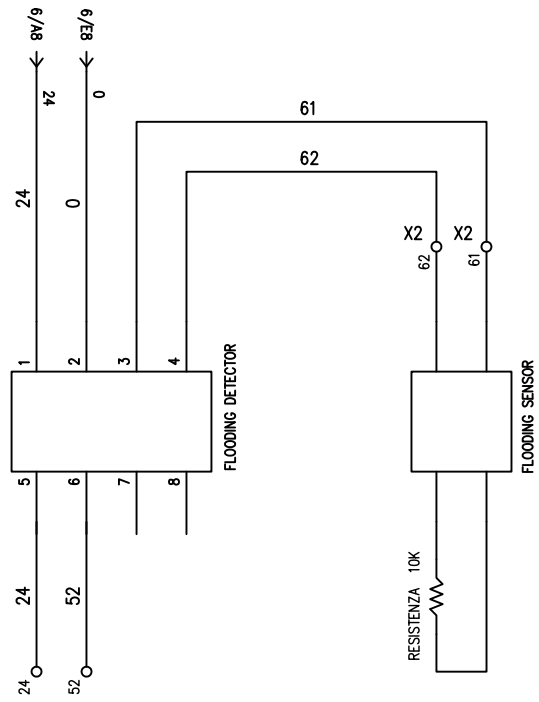

KIT FLOODING DETECTOR
OPTION

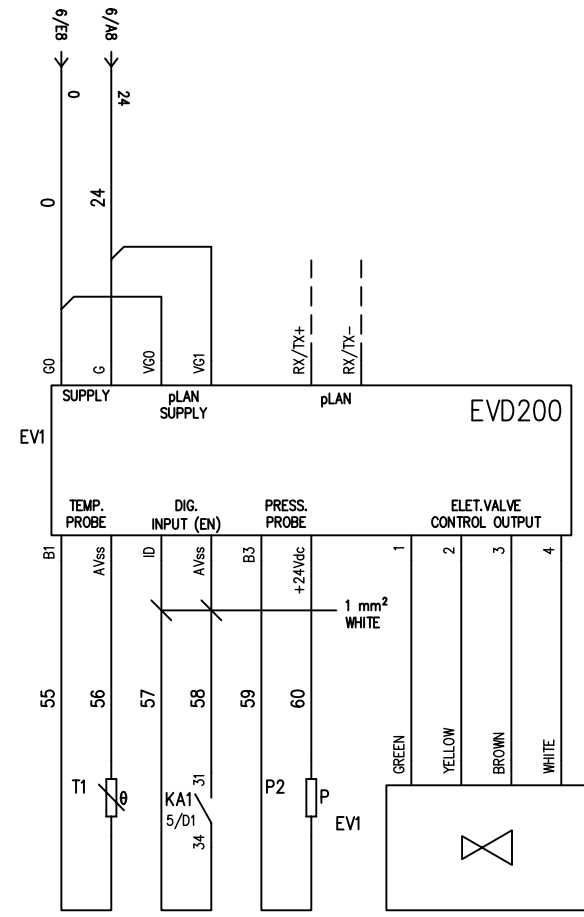

ELECTRONIC EXPANSION
VALVE OPTION

DATE 18/03/2008
 DRAW. N.C.1
 CHECK F.F.1
 APPR. M.M.



HF620C0812

SHEET 9 OF 20
 CONTINUE 10

REV.	MODIFICATIONS	DATE	SIGN.
1		2	3

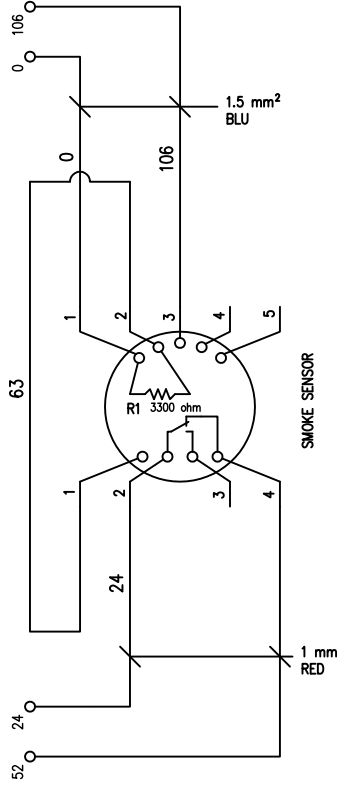

SMOKE SENSOR OPTION

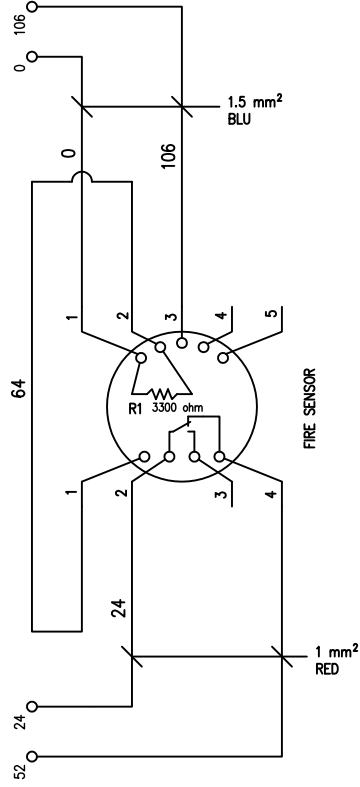

FIRE SENSOR OPTION

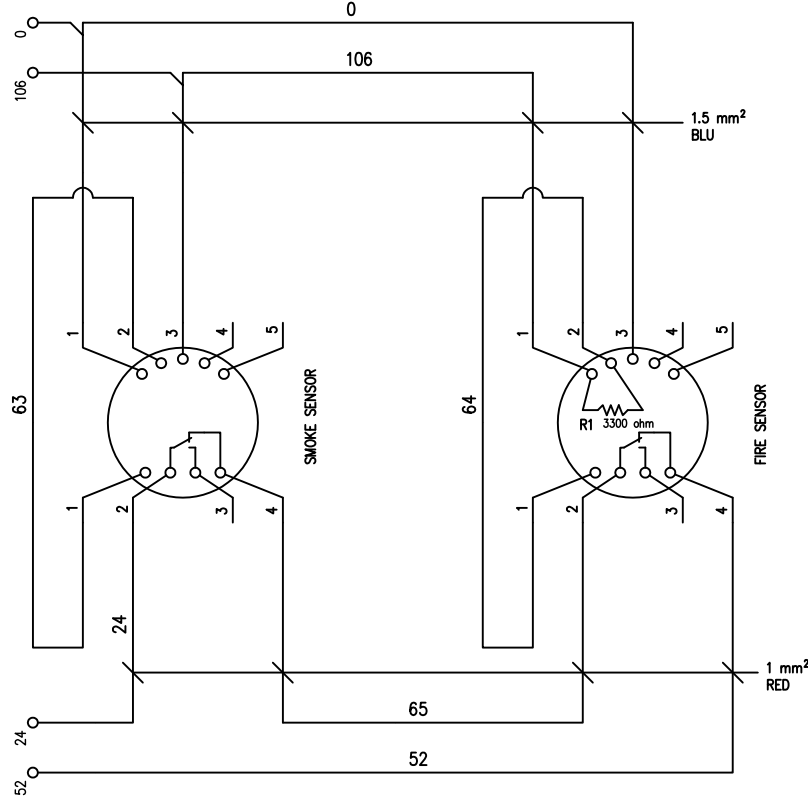

SMOKE/FIRE SENSOR OPTION

REV.	MODIFICATIONS	DATE	SIGN.

DATE	18/03/2008
DRAW.	N.C.1
CHECK	F.F.1
APPR.	M.M.



HF620C0812

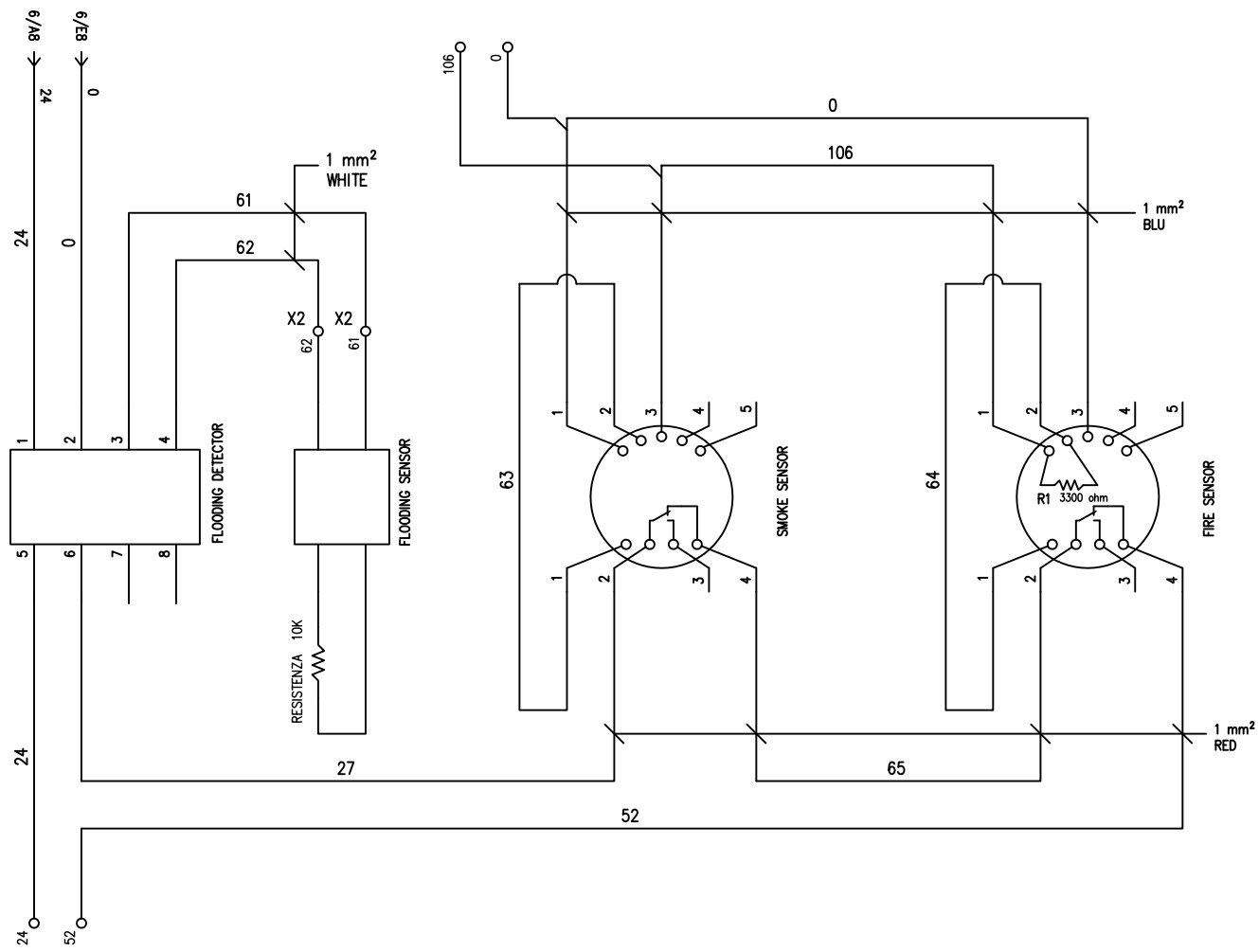

FLOODING, SMOKE AND FIRE ALARM
OPTION

DATE 18/03/2008
 DRAW. N.C.1
 CHECK F.F.1
 APPR. M.M.



HF620C0812

SHEET 11 OF 20
 CONTINUE 12

REV.	MODIFICATIONS	DATE	SIGN.

pLAN CONNECTION

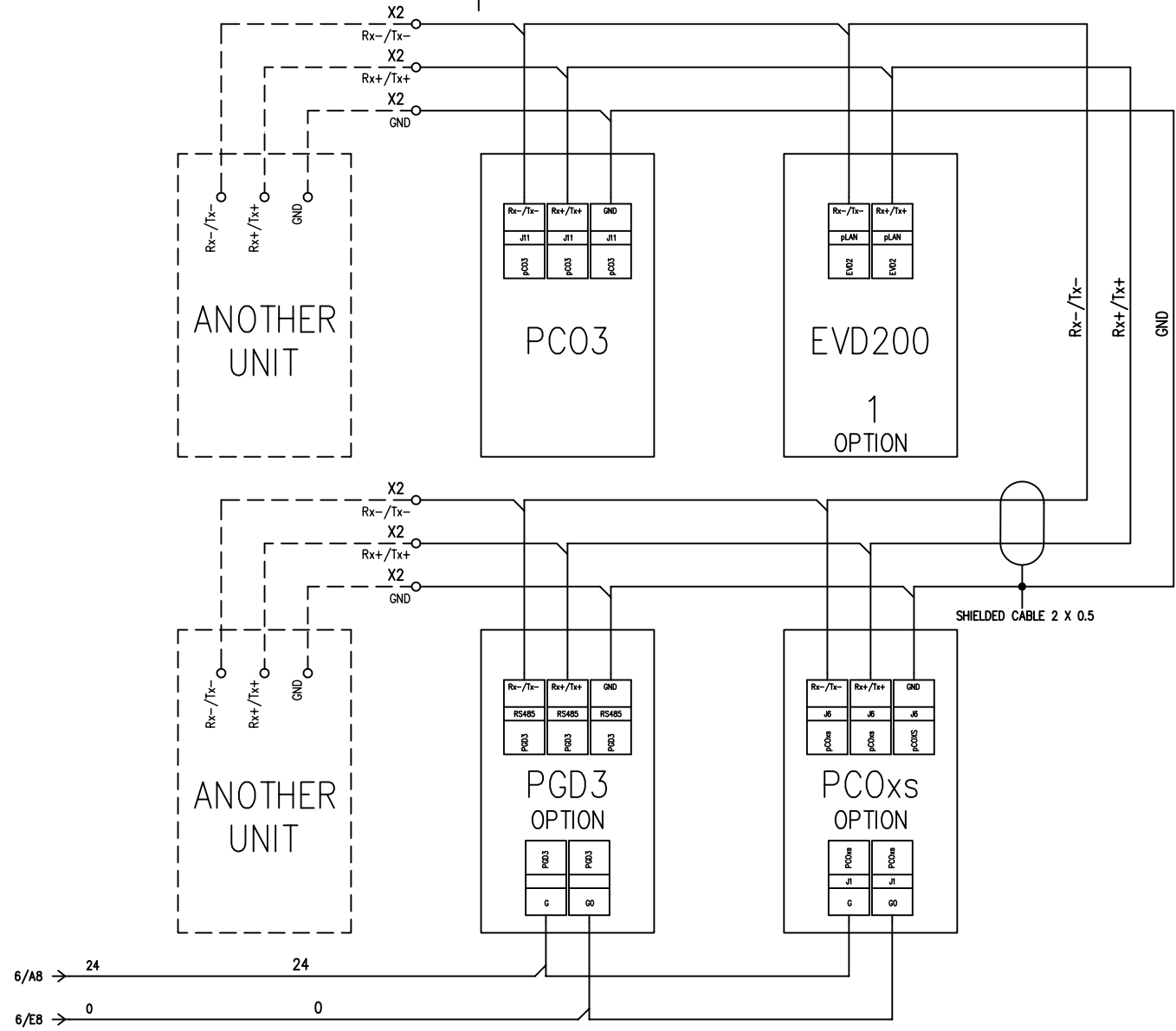

DATE 18/03/2008
 DRAW. N.C.1
 CHECK F.F.1
 APPR. M.M.



HF620C0812

SHEET 12 OF 20
 CONTINUE 13

REV.	MODIFICATIONS	DATE	SIGN.
1		2	3

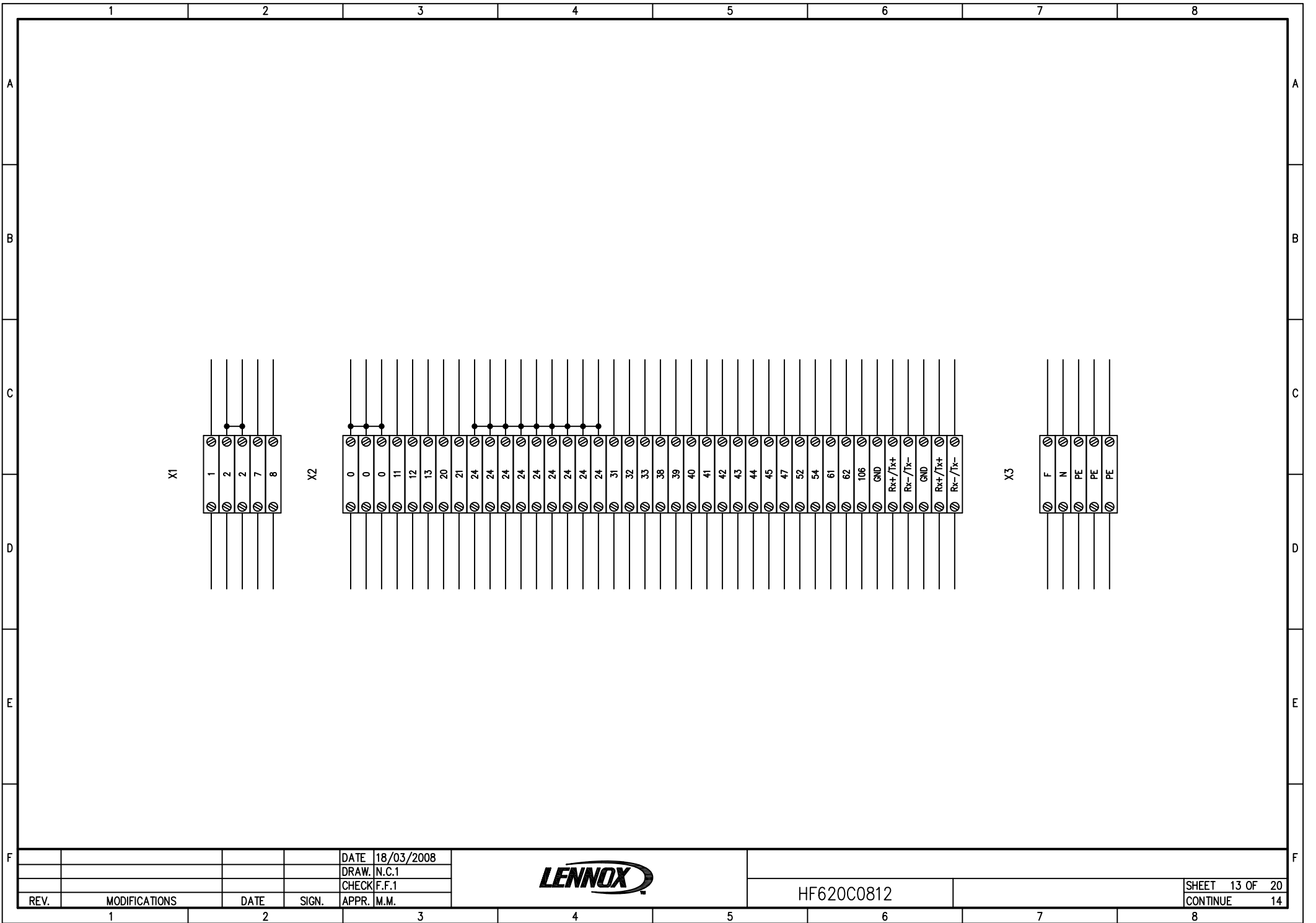

REV.	MODIFICATIONS	DATE	SIGN.	DATE 18/03/2008
				DRAW. N.C.1
				CHECK F.F.1
				APPR. M.M.



HF620C0812

LA LUNGHEZZA DEI CAVI E' RIFERITA ALL'ESTERNO DEL QUADRO

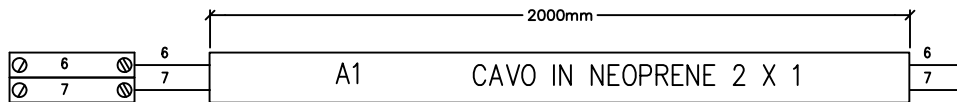
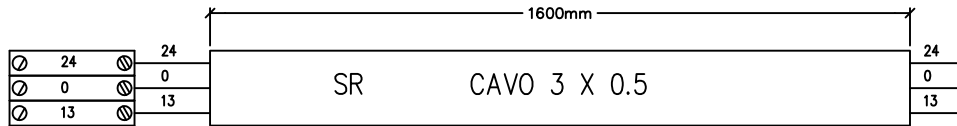
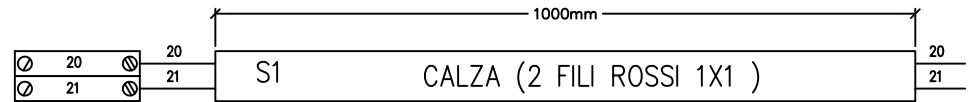
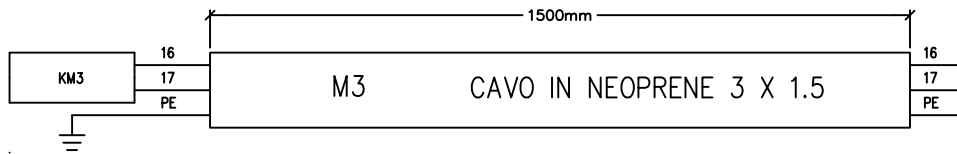
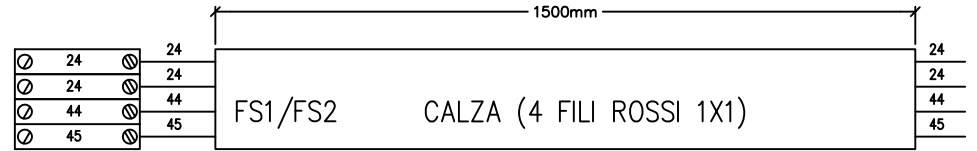
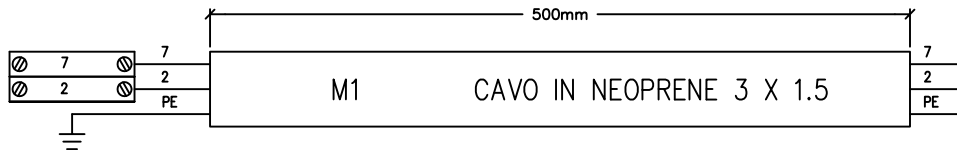
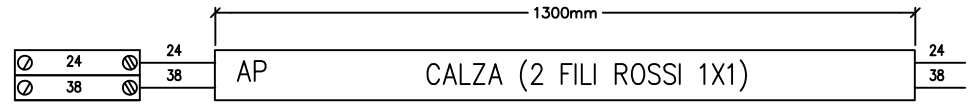
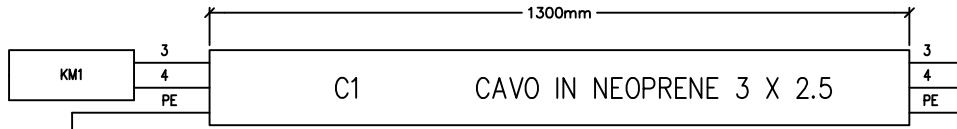

DATE 18/03/2008
 DRAW. N.C.1
 CHECK F.F.1
 APPR. M.M.



HF620C0812

SHEET 14 OF 20
 CONTINUE 15

REV.	MODIFICATIONS	DATE	SIGN.

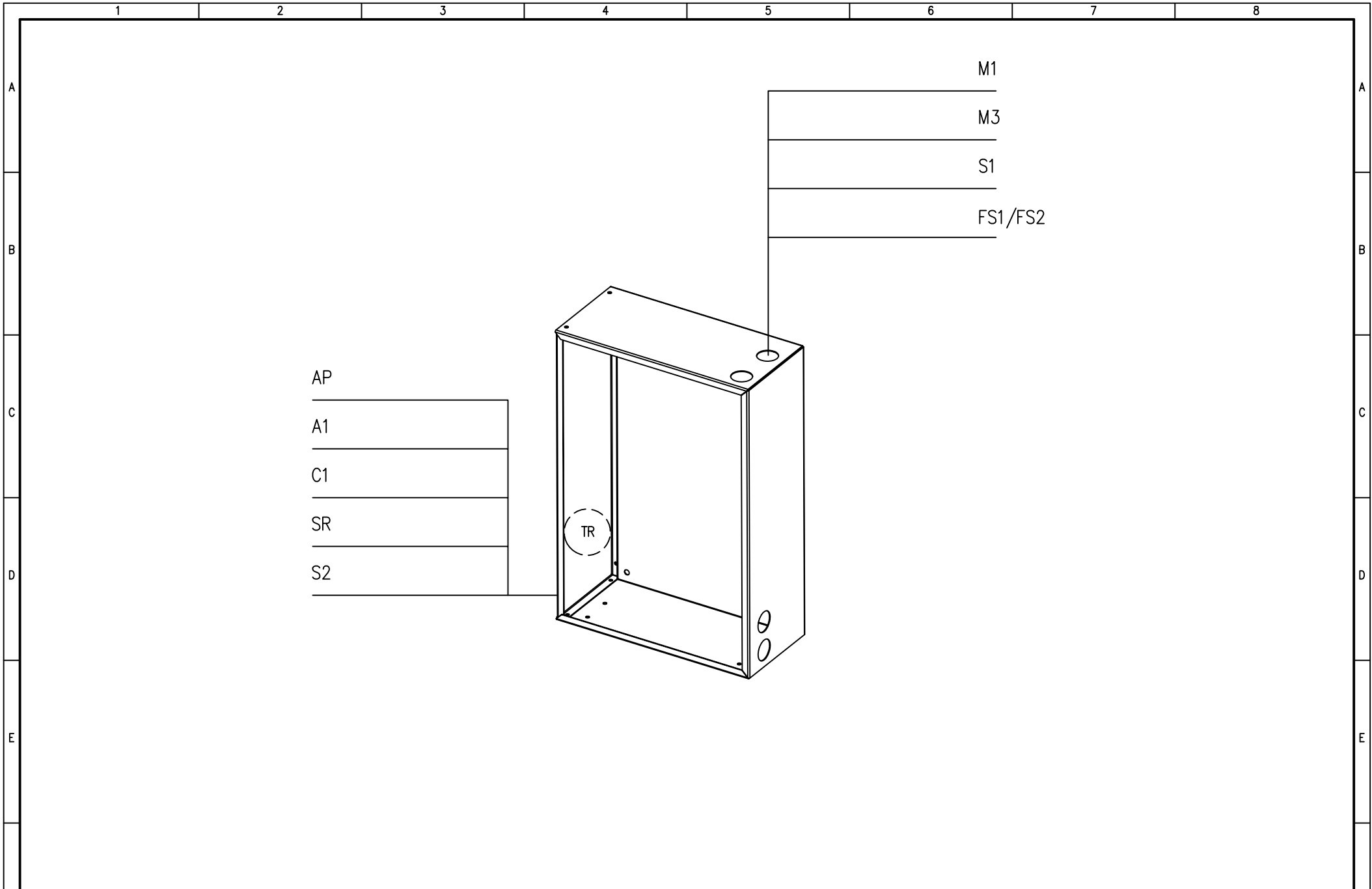

M1

M3

S1

FS1/FS2

AP

A1

C1

SR

S2

TR



DATE	18/03/2008
DRAW.	N.C.1
CHECK	F.F.1
APPR.	M.M.

HF620C0812

SHEET 15 OF 20
CONTINUE 16

REV.	MODIFICATIONS	DATE	SIGN.

1

2

3

4

5

6

7

8

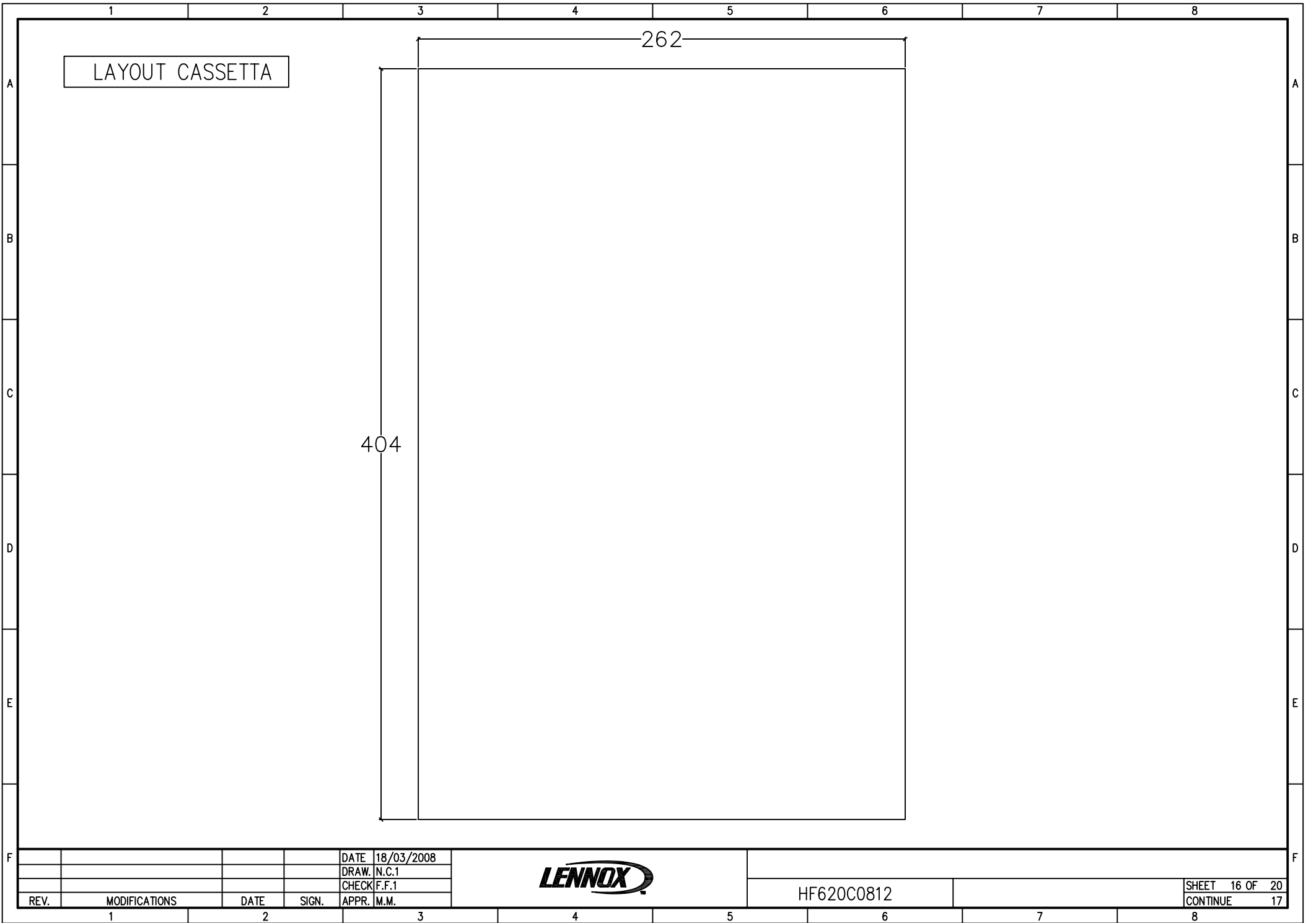

				DATE 18/03/2008
				DRAW. N.C.1
				CHECK F.F.1
REV.	MODIFICATIONS	DATE	SIGN.	APPR. M.M.



HF620C0812

SHEET 16 OF 20
CONTINUE 17

LAYOUT GUIDE DIN

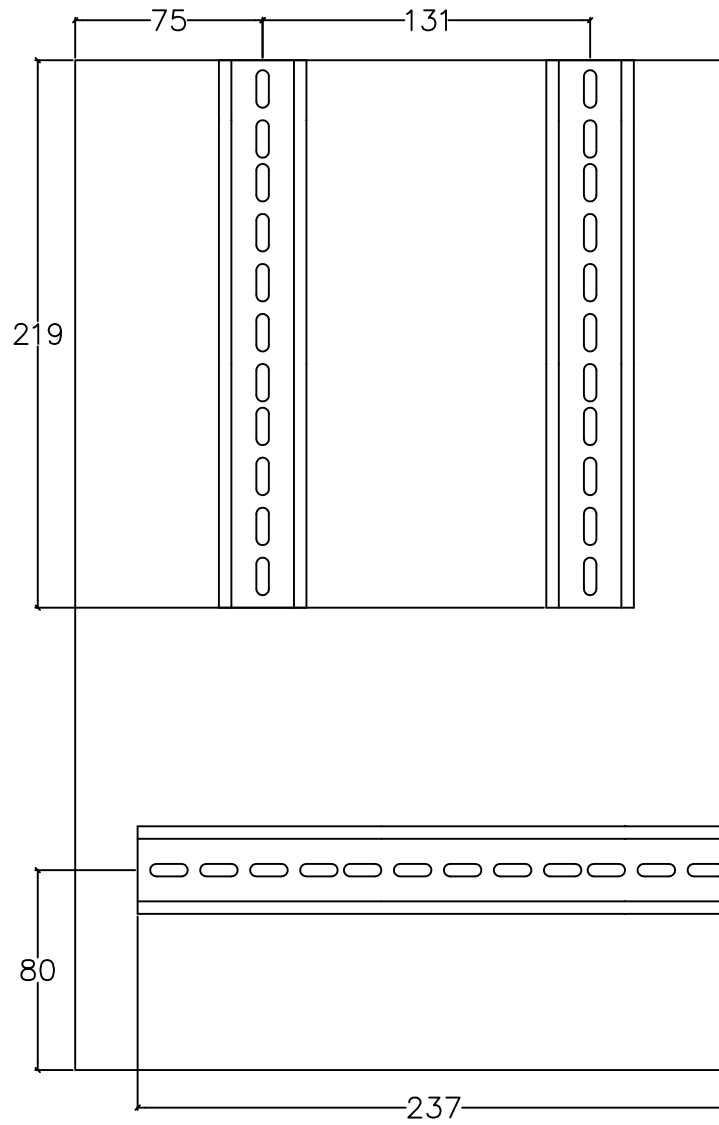

REV.	MODIFICATIONS	DATE	SIGN.	DATE 18/03/2008
				DRAW. N.C.1
				CHECK F.F.1
				APPR. M.M.



HF620C0812

LAYOUT CANALINE

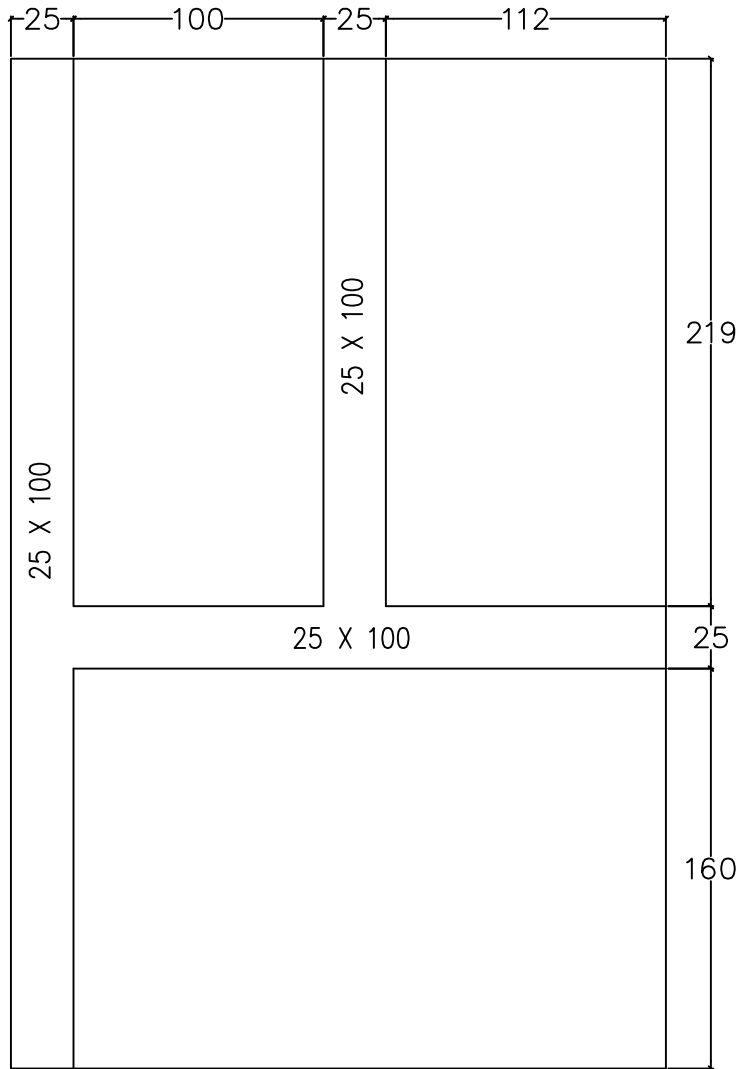

DATE	18/03/2008
DRAW.	N.C.1
CHECK	F.F.1
APPR.	M.M.



HF620C0812

SHEET	18 OF	20
CONTINUE		19

REV.	MODIFICATIONS	DATE	SIGN.

1

2

3

4

5

6

7

8

LAYOUT COMPONENTI

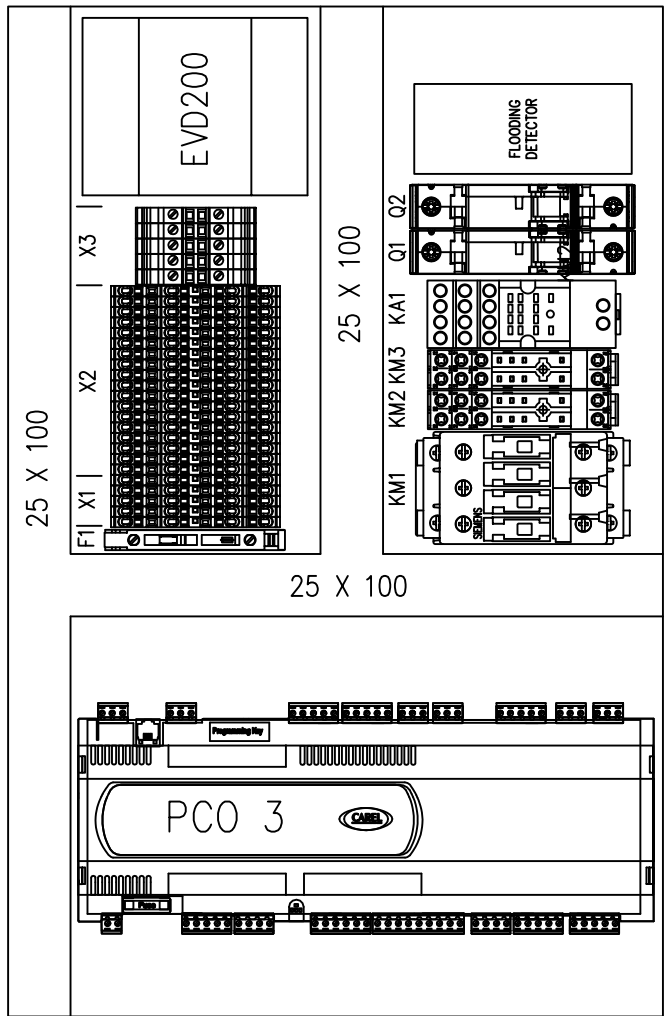

REV.	MODIFICATIONS	DATE	SIGN.	DATE 18/03/2008
				DRAW. N.C.1
				CHECK F.F.1
				APPR. M.M.



HF620C0812

1	2	3	4	5	6	7	8	
UBICAZIONE	SIGLA	FUNZIONE	MARCA	CODICE	DESCRIZIONE	QUANTITA'	M.U.	POSIZIONE
A	Q1	PROTEZIONE GENERALE COMPRESSORE	SIEMENS	5SY6 025-7	INT. AUT. 1P + N C25 6KA	1	PCE	A
	Q2	PROTEZIONE GENERALE FREE COOLING	SIEMENS	5SY6 006-7	INT. AUT. 1P + N C6 6KA	1	PCE	
	Q1	CONTATTO AUSILIARIO 1NA + 1NC	SIEMENS	5ST3 010	CONTATTO AUSILIARIO 1NA + 1NC	1	PCE	
B	KA1	ABILITAZIONE ON/OFF COMPRESSORE	FINDER	55348024 + 9474 + 09471	RELE' + ZOCCOLO + PONTICELLO DI RITENUTA	1	PCE	B
	KM1	ON/OFF COMPRESSORE	SIEMENS	3RT1026-1AB00	TELERUTTORE 11KW 400V 3P BOB. 24V AC	1	PCE	
	KM2	ON/OFF RESISTENZE	FINDER	40528024 + 9505 + 09571	RELE' + ZOCCOLO + PONTICELLO DI RITENUTA (INSTALLARE SOLO ZOCCOLO)	1	PCE	
	KM3	ON/OFF VENTILATORE EVAPORANTE	FINDER	40528024 + 9505 + 09571	RELE' + ZOCCOLO + PONTICELLO DI RITENUTA	1	PCE	
C	F1	FUSIBILE	ITALWEBER	0104004	FUSIBILE CILINDRICO DI VETRO In=4A	1	PCE	C
	F	PORTA FUSIBILE	PHOENIX	3004100	MORSETTO PORTAFUSIBILE UK5-HESI	1	PCE	
	TR	TRASFORMATORE TOROIDALE	MARINI		TRASFORMATORE V1=230V/V2=24V S = 100VA DA INSTALLARE LATERALMENTE AL QUADRO ELETTRICO	1	PCE	
	S1	INTERRUTTORE ON/OFF	MOLVENO	HF40000546	INTERRUTTORE I - 0 NERO (IL QUADRISTA NON DEVE INSTALLARLO)	1	PCE	D
D	S2	INTERRUTTORE FINECORSA	PIZZATO	HF40000544	INTERRUTTORE FINECORSA (IL QUADRISTA NON DEVE INSTALLARLO)	1	PCE	D
	-	CASSA + PANNELLO LATERALE	HIREF	HF17001356 + HF17001358	CASSA + PANNELLO LATERALE	1	PCE	
	-	PIASTRA DI FONDO	HIREF	HF17001357	PIASTRA DI FONDO	1	PCE	
E	X1 / X2	MORSETTIERA	PHOENIX	3031157	MORSETTO A MOLLA A DUE LIVELLI STTB 1,5	23	PCE	E
	X3	MORSETTIERA	PHOENIX	3044102	MORSETTO A VITE UT 4	2	PCE	
	X3	MORSETTO DI TERRA	PHOENIX	3044128	MORSETTO A VITE UT 4-PE	3	PCE	
F								
				DATE 18/03/2008				
				DRAW. N.C.1				
				CHECK F.F.1				
REV.	MODIFICATIONS	DATE	SIGN.	APPR. M.M.		HF620C0812		SHEET 20 OF 20 CONTINUE
1	2	3	4	5	6	7	8	