



CARATTERISTICHE ELETTRICHE
ELECTRIC CHARACTERISTIC

SERIES DHCD/UR300...1000-pCO1

Revisione	Foglio	Oggetto	Data	Responsabile
A	1	REVISIONE GENERALE	09/09/2005	POLIDO
B	1	REVISIONE SERRANDA	13/09/2005	
C	1	TOLTO Q1 AGGIUNTO F2	04/05/2006	POLIDO
D	1	colleg. sens fumo	30/03/2007	FF
E	1	REVISIONE GENERALE	16/04/2007	C.N.
F	1	SOSTITUITO Q5	25/06/2007	C.N.
G	1	INSERITA CONNESSIONE PGD3	15/10/2007	C.N.
H	1	AGGIUNTA UNA RESISTENZA	18/03/2008	C.N.

T-REF F					T-REF F+U				
	<i>P tota[kW]</i>	<i>OA [A]</i>	<i>FLA [A]</i>	<i>LRA [A]</i>		<i>P tota[kW]</i>	<i>OA [A]</i>	<i>FLA [A]</i>	<i>LRA [A]</i>
TREF CW 0300	1,482	3,9	3,9	0	TREF CW 0300	7,482	30,0	30,0	0
TREF CW 0380	1,482	3,9	3,9	0	TREF CW 0380	7,482	30,0	30,0	0
TREF CW 0400	2,756	7,6	7,6	0	TREF CW 0400	8,756	33,7	33,7	0
TREF CW 0500	2,816	7,6	7,6	0	TREF CW 0500	8,816	33,7	33,7	0
TREF CW 0650	2,942	7,7	7,7	0	TREF CW 0650	8,942	33,8	33,8	0
TREF CW 0750	2,942	7,7	7,7	0	TREF CW 0750	8,942	33,8	33,8	0
TREF CW 0900	4,323	11,6	11,6	0	TREF CW 0900	10,323	37,6	37,6	0
TREF CW 1000	4,476	11,6	11,6	0	TREF CW 1000	10,476	37,7	37,7	0

T-REF F+C					T-REF F+C+U				
	<i>P tota[kW]</i>	<i>OA [A]</i>	<i>FLA [A]</i>	<i>LRA [A]</i>		<i>P tota[kW]</i>	<i>OA [A]</i>	<i>FLA [A]</i>	<i>LRA [A]</i>
TREF CW 0300	7,882	31,7	31,7	0	TREF CW 0300	13,882	57,8	57,8	0
TREF CW 0380	11,082	45,6	45,6	0	TREF CW 0380	17,082	71,7	71,7	0
TREF CW 0400	9,156	35,4	35,4	0	TREF CW 0400	15,156	61,5	61,5	0
TREF CW 0500	9,216	35,5	35,5	0	TREF CW 0500	15,216	61,5	61,5	0
TREF CW 0650	12,542	49,4	49,4	0	TREF CW 0650	18,542	75,5	75,5	0
TREF CW 0750	15,742	63,3	63,3	0	TREF CW 0750	21,742	89,4	89,4	0
TREF CW 0900	13,923	53,3	53,3	0	TREF CW 0900	19,923	79,4	79,4	0
TREF CW 1000	14,076	53,4	53,4	0	TREF CW 1000	20,076	79,5	79,5	0

VERS.

"F"= SOLO FREDDO-ONLY COOLING
 "F+C"= FREDDO/CALDO-ONLY COOLING/HEATING
 "F+U"= FREDDO/UMIDITA'-COOLING/HUMIDITY
 "F+C+U"= FREDDO/CALDO/UMIDITA'- COOLING/HEATING/HUMIDITY

D	colleg. sens fumo	30/03/2007	FF	DATE	14/07/2005				
E	REVISIONE GENERALE	16/04/2007	C.N.	DRAW.	P.M.				
F	SOSTITUITO Q5	25/06/2007	C.N.	CHECK	P.M.				
REV.	MODIFICATIONS	DATE	SIGN.	APPR.	M.M.	REPLACE	REPLACE	ORIGIN:	



HF620C0302

SHEET 1 OF 21
CONTINUE 2

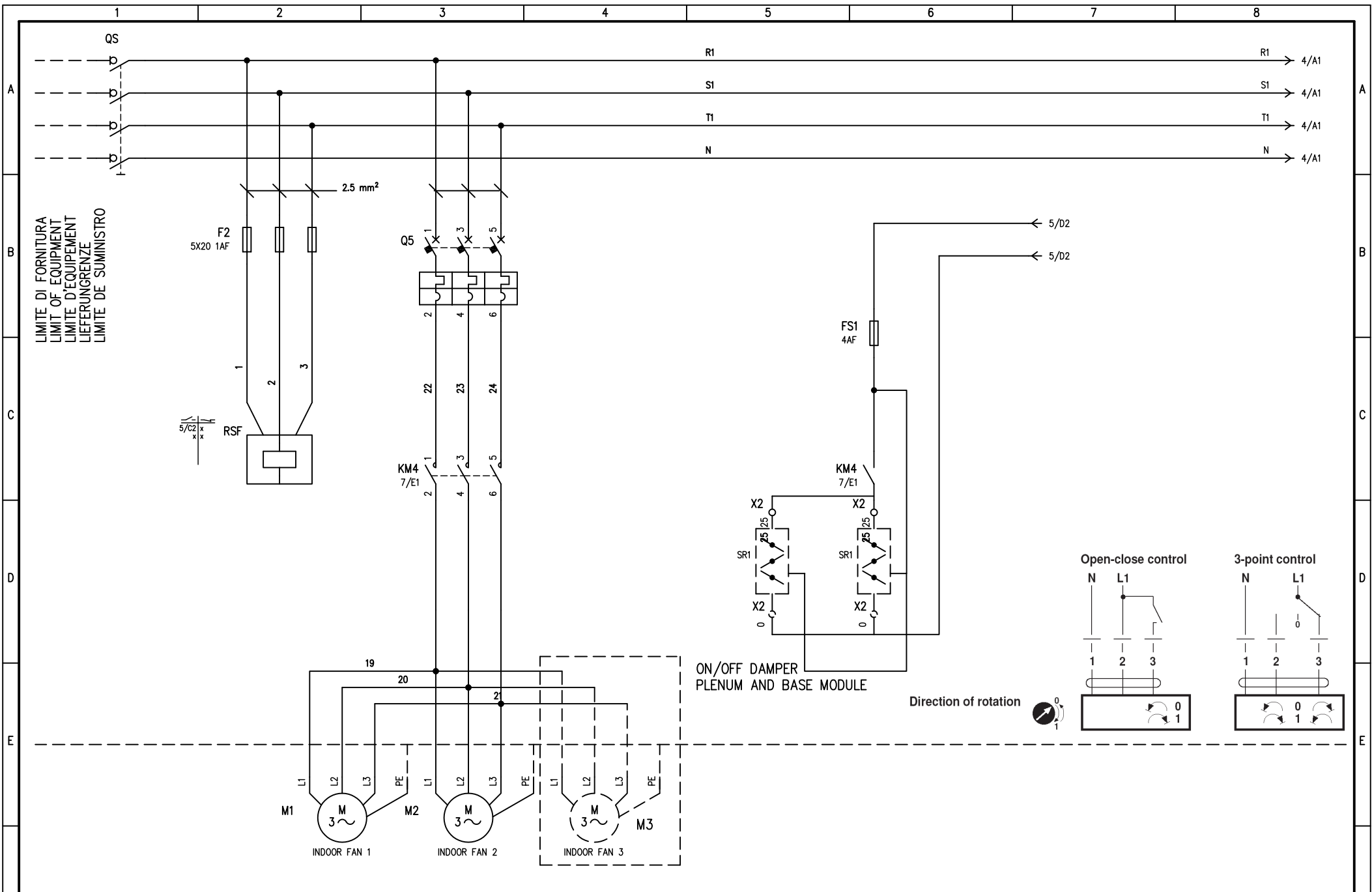

				DATE 14/07/2005				LENNOX							
				DRAW. P.M.											
				CHECK P.M.											
REV.	MODIFICATIONS	DATE	SIGN.	APPR.	M.M.	REPLACE	REPLACE	ORIGIN:					HF620C0302	SHEET 3 OF 21	
1		2		3		4		5	6	7	8	CONTINUE 4			

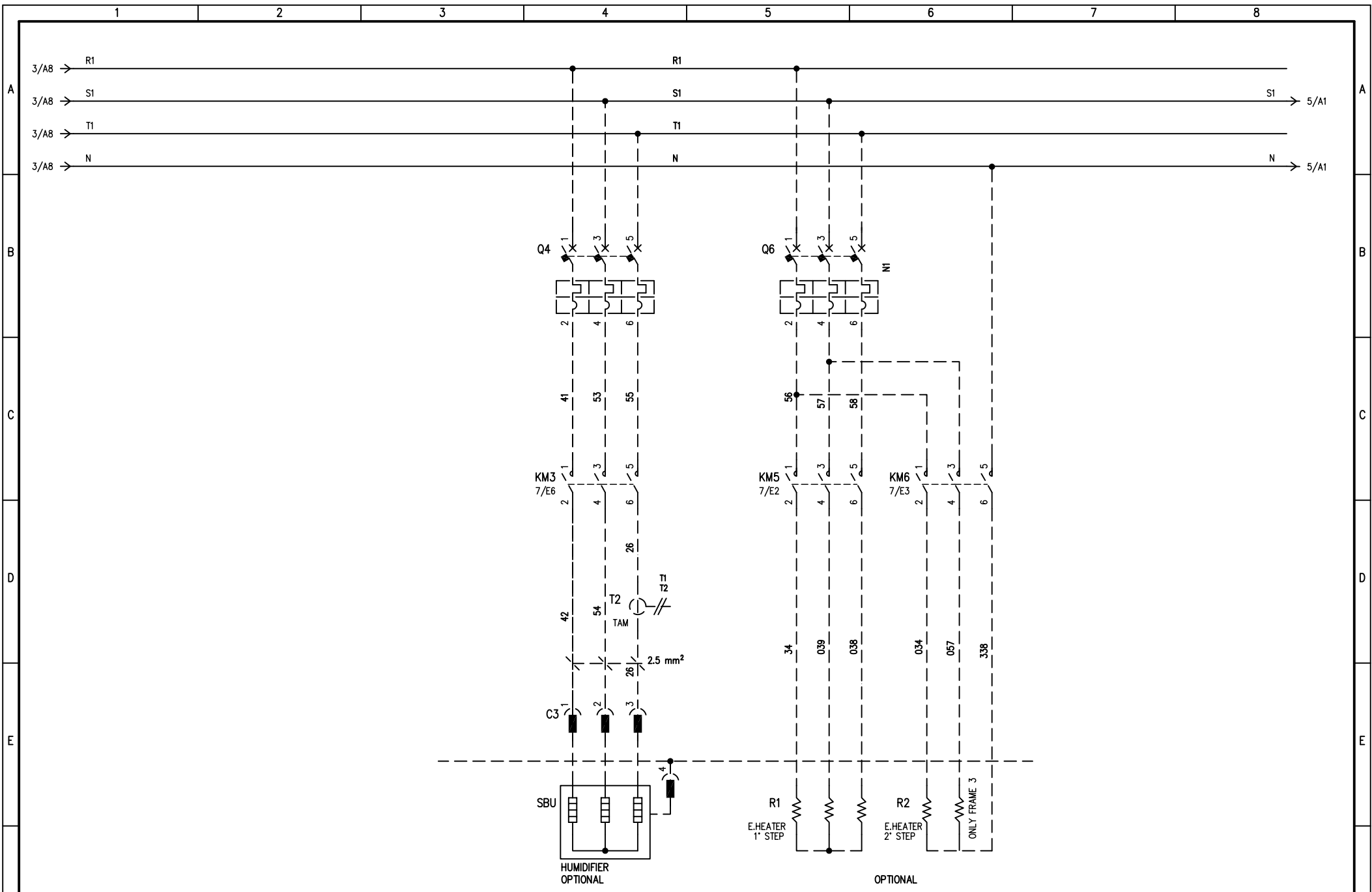

				DATE 14/07/2005				LENNOX							
				DRAW. P.M.											
				CHECK P.M.											
REV.	MODIFICATIONS	DATE	SIGN.	APPR.	M.M.	REPLACE	REPLACE	ORIGIN:			HF620C0302		SHEET 4 OF 21		
1		2		3		4		5			6	7	8		
												CONTINUE	5		

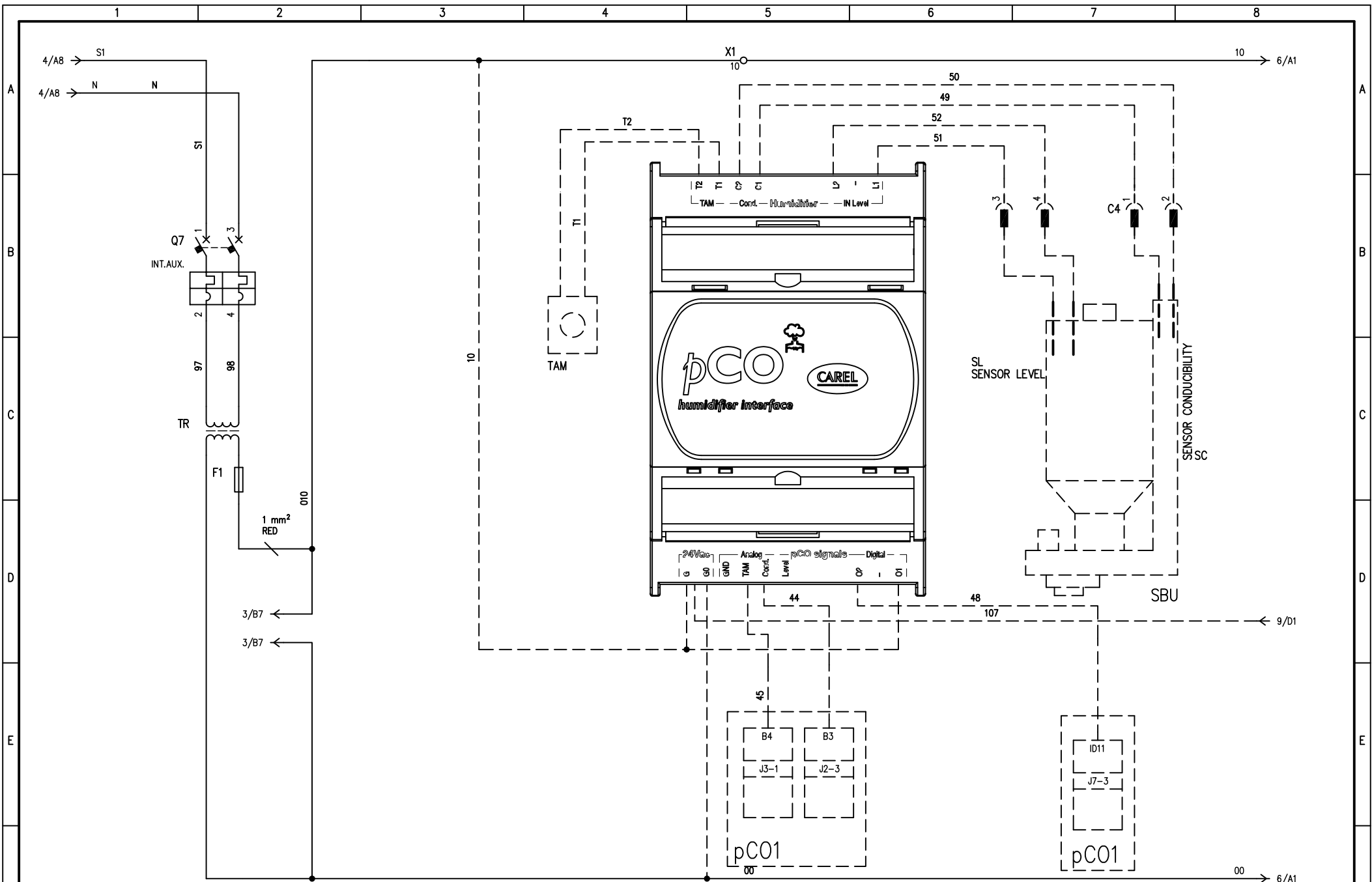

REV.	MODIFICATIONS	DATE	SIGN.	APPR.	M.M.	REPLACE	REPLACE	ORIGIN:
1								
2								
3								
4								
5								
6								
7								
8								

DATE	14/07/2005
DRAW.	P.M.
CHECK	P.M.

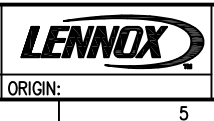

HF620C0302

SHEET 5 OF 21
CONTINUE 6

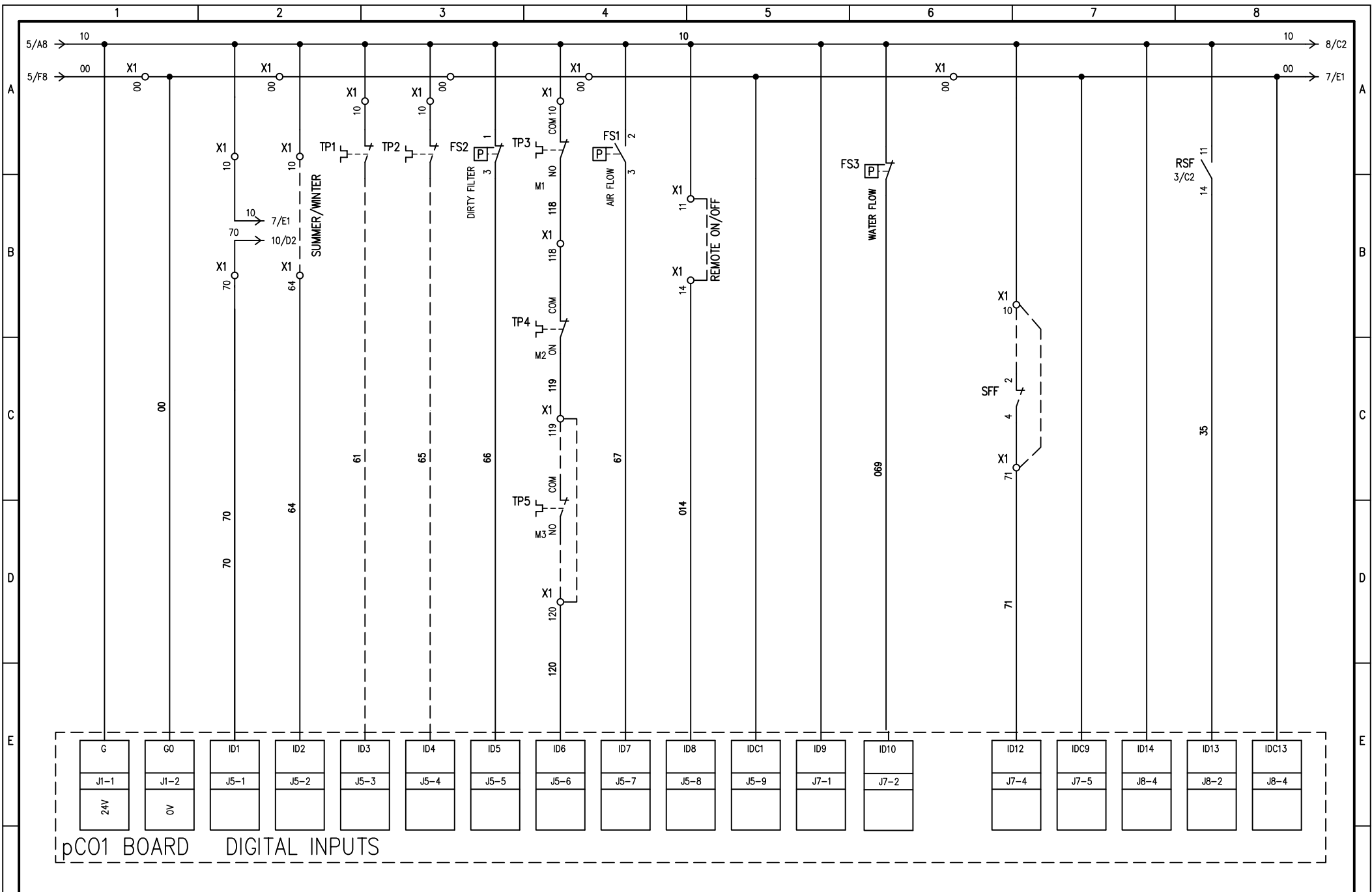

pCO1 BOARD DIGITAL INPUTS

G	G0	ID1	ID2	ID3	ID4	ID5	ID6	ID7	ID8	IDC1	ID9	ID10	ID12	IDC9	ID14	ID13	IDC13
J1-1	J1-2	J5-1	J5-2	J5-3	J5-4	J5-5	J5-6	J5-7	J5-8	J5-9	J7-1	J7-2	J7-4	J7-5	J8-4	J8-2	J8-4
24V	0V																

DATE 14/07/2005
 DRAW. P.M.
 CHECK P.M.
 APPR. M.M.



pCO1 DIGITAL OUTPUTS

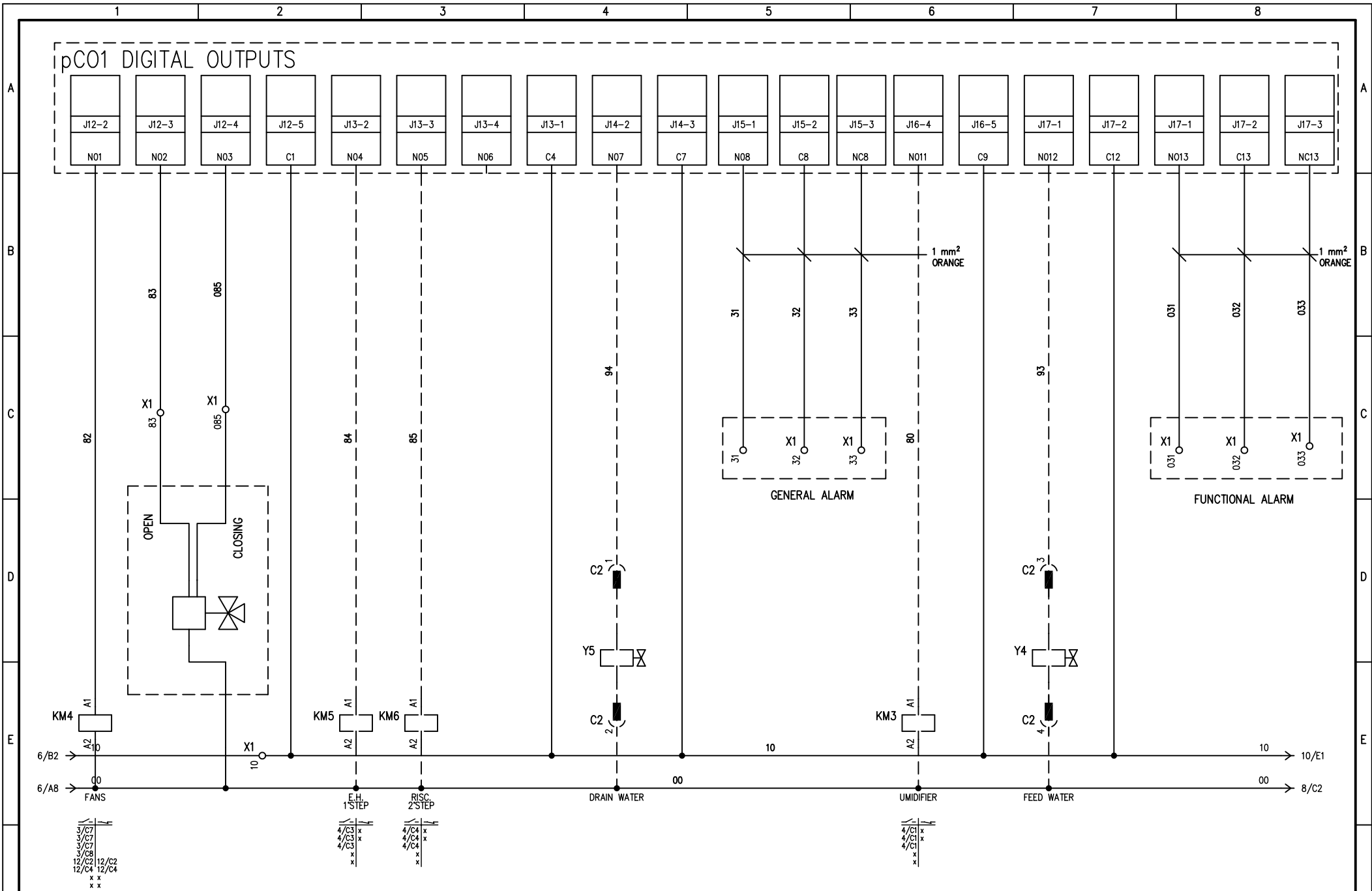

REV.		MODIFICATIONS		DATE	14/07/2005	DATE		14/07/2005		DRAW. P.M.		CHECK P.M.		ORIGIN:		HF620C0302		SHEET 7 OF 21	
																		CONTINUE 8	



CONTROLLO VENTILATORI
FANS MOTOR CONTROL
CONTROL VENTILATEUR

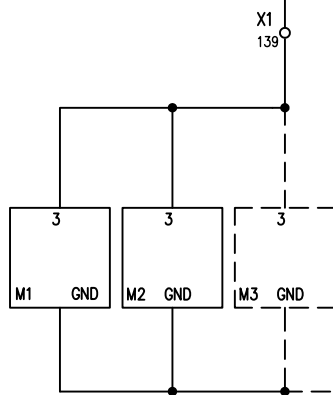
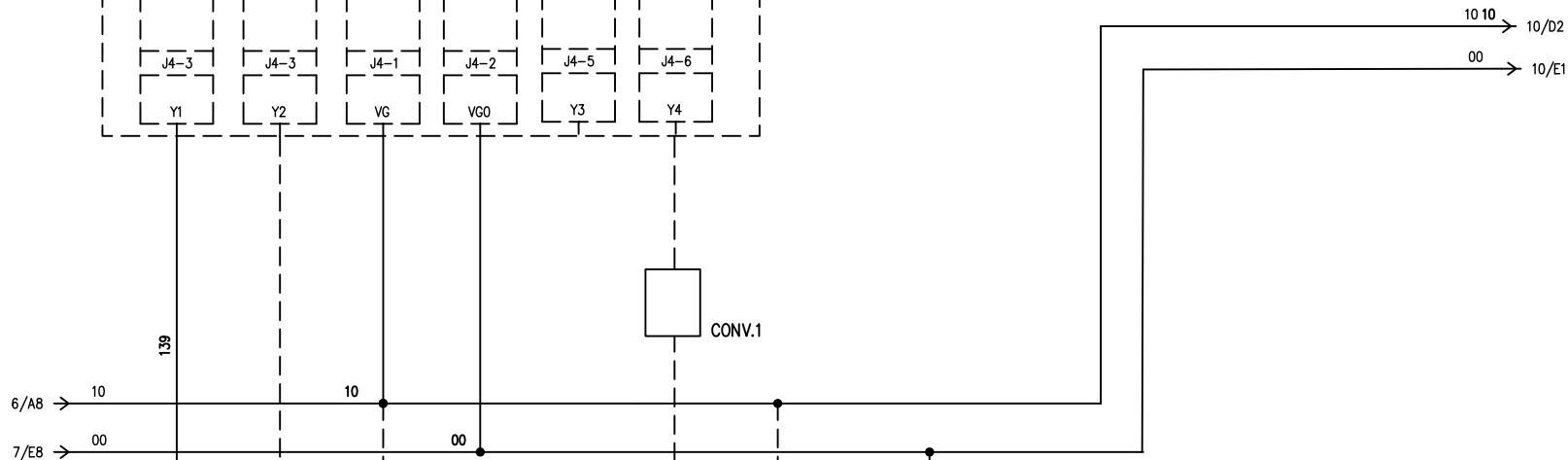
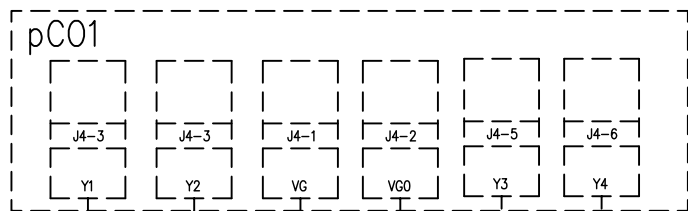

EC FANS 0-10V SIGNAL

VALVOLA ACQUA FREDDA (OPZ.)
COLD WATER VALVE (OPT.)
VANNE DE REGUL. EAU CHAUDE (OPT.)
WEGEWARMWASSERVENTIL (ZUB.)
VALVILA AGUA FRIA (OPC.)

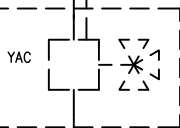

VALVOLA ACQUA CALDA (OPZ.)
HOT WATER VALVE (OPT.)
VANNE DE REGUL. EAU CHAUDE (OPT.)
WEGEWARMWASSERVENTIL (ZUB.)
VALVILA AGUA CALIENTE (OPC.)

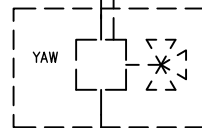

DATE 14/07/2005		DRAW. P.M.		CHECK P.M.		ORIGIN:		HF620C0302		SHEET 8 OF 21	
REV.	MODIFICATIONS	DATE	SIGN.	APPR.	M.M.	REPLACE	REPLACE	ORIGIN:	HF620C0302		CONTINUE 9
1		2		3		4		5	6	7	8



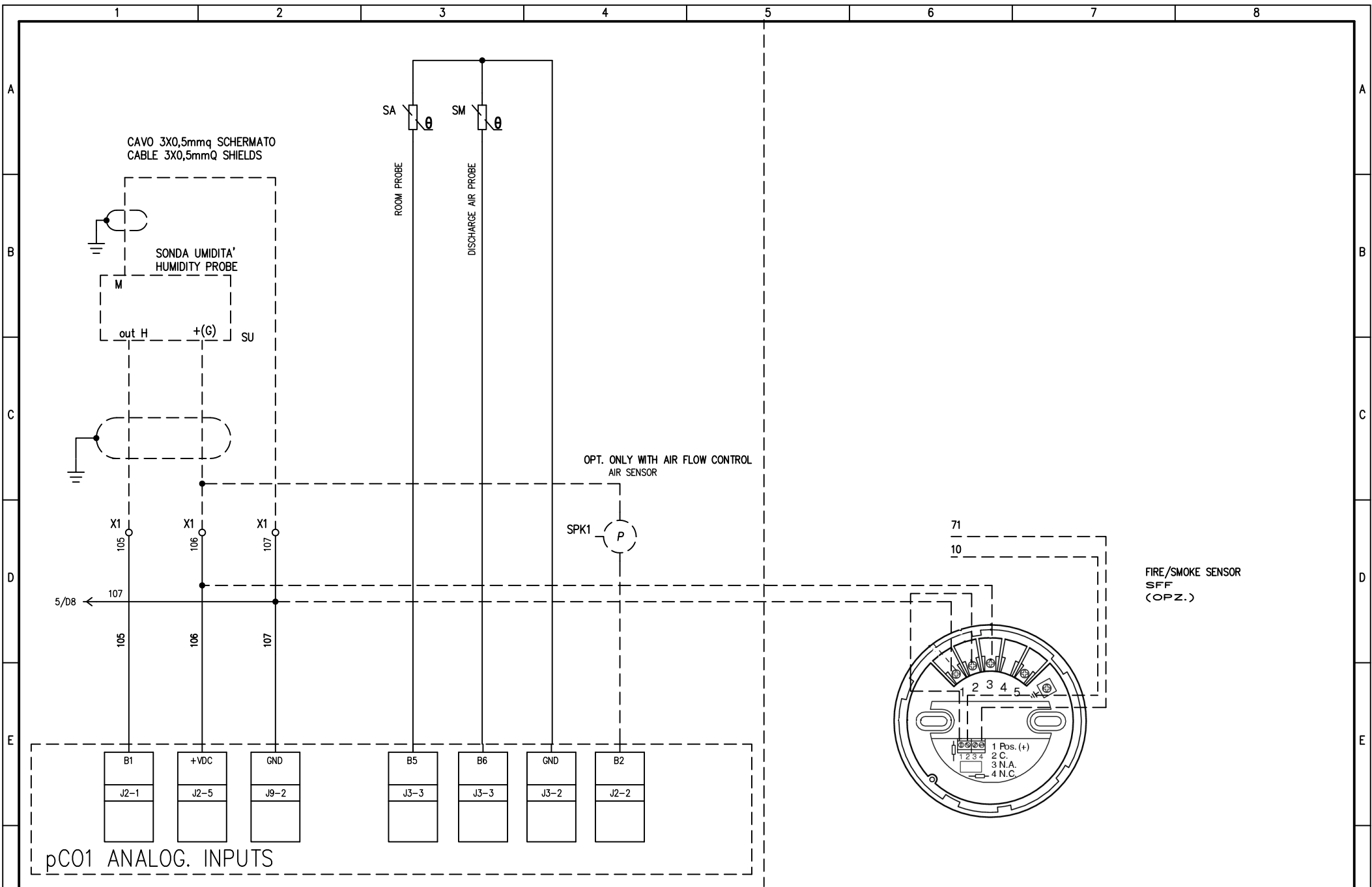

				DATE	14/07/2005			LENNOX				
				DRAW.	P.M.							
				CHECK	P.M.							
REV.	MODIFICATIONS	DATE	SIGN.	APPR.	M.M.	REPLACE	REPLACE	ORIGIN:			HF620C0302	SHEET 9 OF 21
1		2		3		4		5	6	7	8	CONTINUE 10

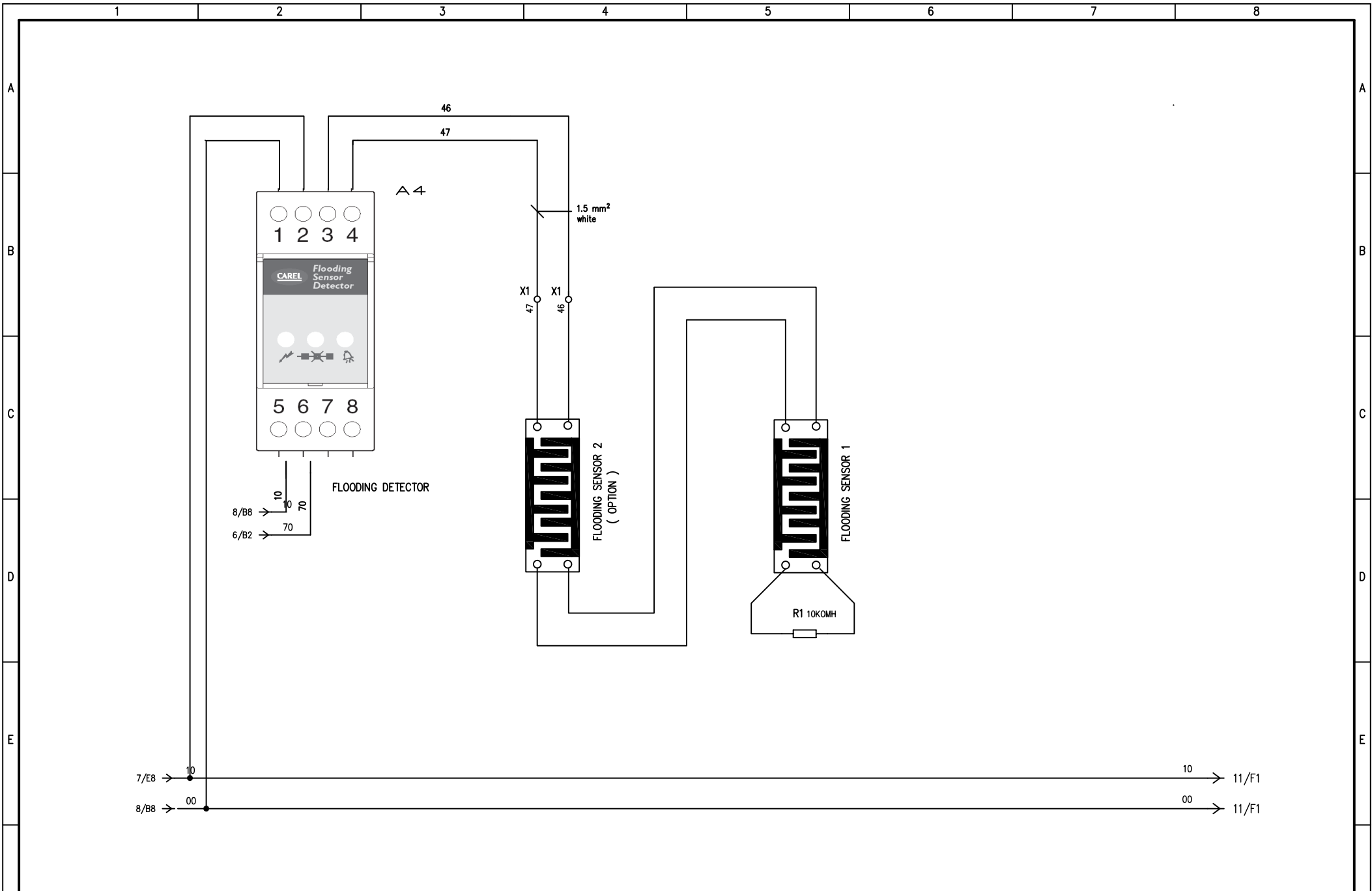

DATE 14/07/2005
 DRAW. P.M.
 CHECK P.M.



REV. MODIFICATIONS

DATE SIGN.

APPR. M.M.

REPLACE

REPLACE

ORIGIN:

HF620C0302

SHEET 10 OF 21
 CONTINUE 11

pCOE BOARD

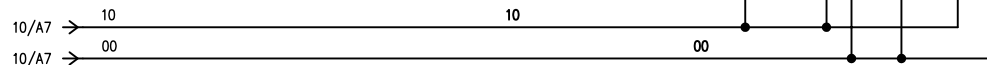
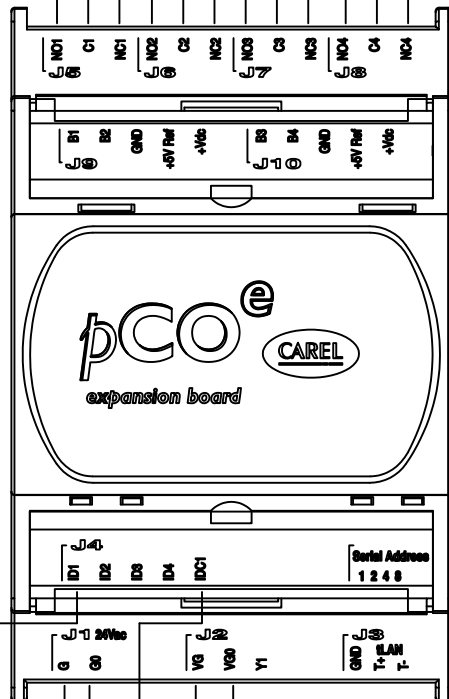
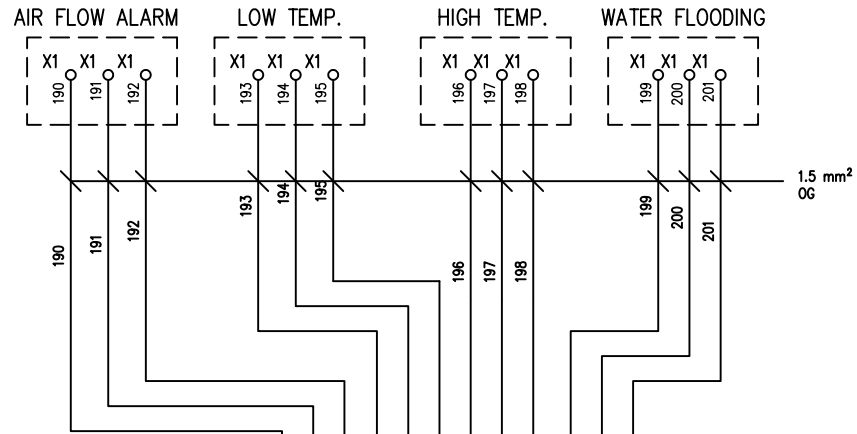

				DATE: 14/07/2005									
				DRAW: P.M.									
				CHECK: P.M.									
REV.	MODIFICATIONS	DATE	SIGN.	APPR.	M.M.	REPLACE	REPLACE	ORIGIN:			HF620C0302		SHEET 11 OF 21
1		2		3		4		5	6	7	8	CONTINUE	12



CONTATTI PULITI SEGNALAZIONE REMOTA
 REMOTE SIGNAL CLEAN CONTACTS
 CONTACTS PROPRES SIGNALISATIONS A DISTANCE
 FREIE KONTAKTE FUER BETRIEBSMELDUNGEN
 CONT. LIMPIOS CON SENGNALIZACIONES REMOTAS

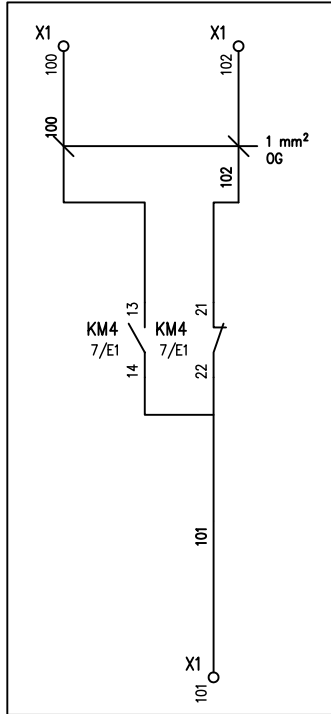

EXT. DAMPER ON/OFF
 FAN ON/OFF SIGNAL

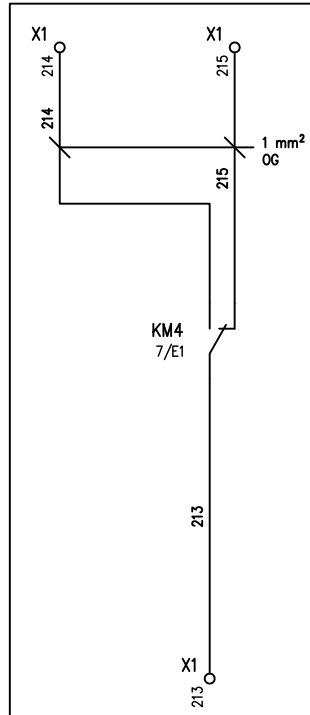

ON/OFF UNIT STATUS

POMPA SCARICO CONDENZA
 CONDENSATE DRAIN PUMP
 POMPE A EAU CONDENSEUY
 KONDENSATWASS PUMPE
 BOMBA DESEGUE CONDEN.

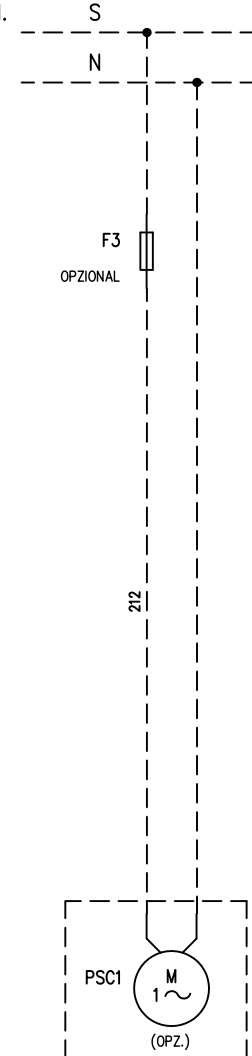

DATE	14/07/2005			LENNOX					
DRAW.	P.M.								
CHECK	P.M.								
REV.	MODIFICATIONS	DATE	SIGN.	APPR.	M.M.	REPLACE	REPLACE	ORIGIN:	
1		2		3		4		5	

HF620C0302

SHEET 12 OF 21
 CONTINUE 13

LAN CONNECTIONS

SHIELD

MAX 8 UNITS

[USARE LA CALZA PER LA CONNESSIONE DEL GND]
USE THE SHIELDS FOR GND CONNECTIONS

[USARE LA CALZA PER LA CONNESSIONE DEL GND]
USE THE SHIELDS FOR GND CONNECTIONS

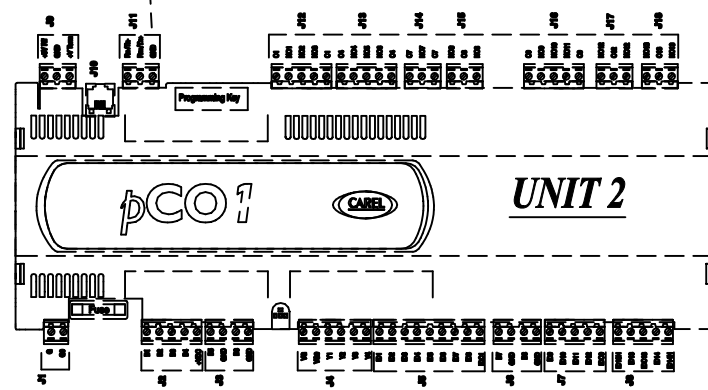
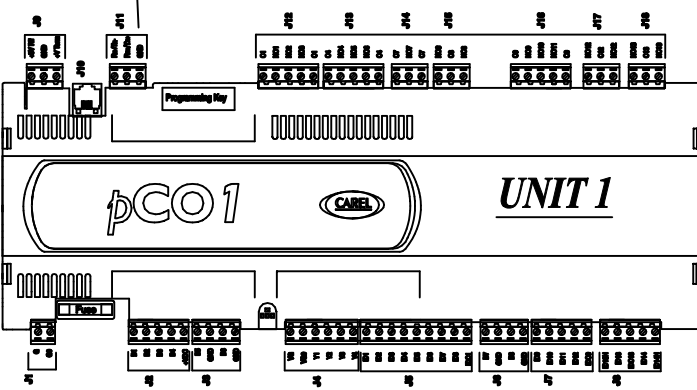
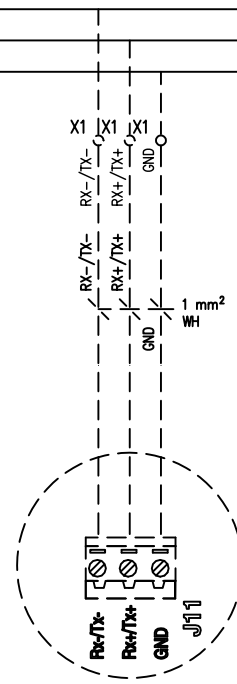
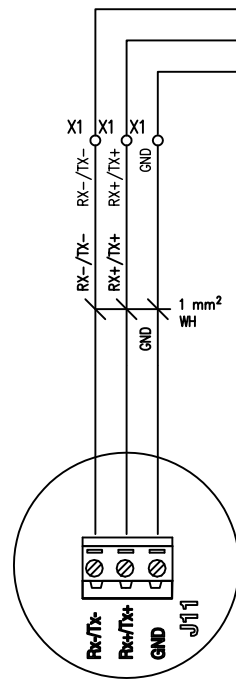

REV.		MODIFICATIONS		DATE		SIGN.		APPR.		M.M.		REPLACE		REPLACE		ORIGIN:		LENNOX		HF620C0302		SHEET 13 OF 21	
																				CONTINUE		14	

F

F

ELECTRICAL CONNECTION OF THE GRAPHICAL DISPLAY (pGD3)

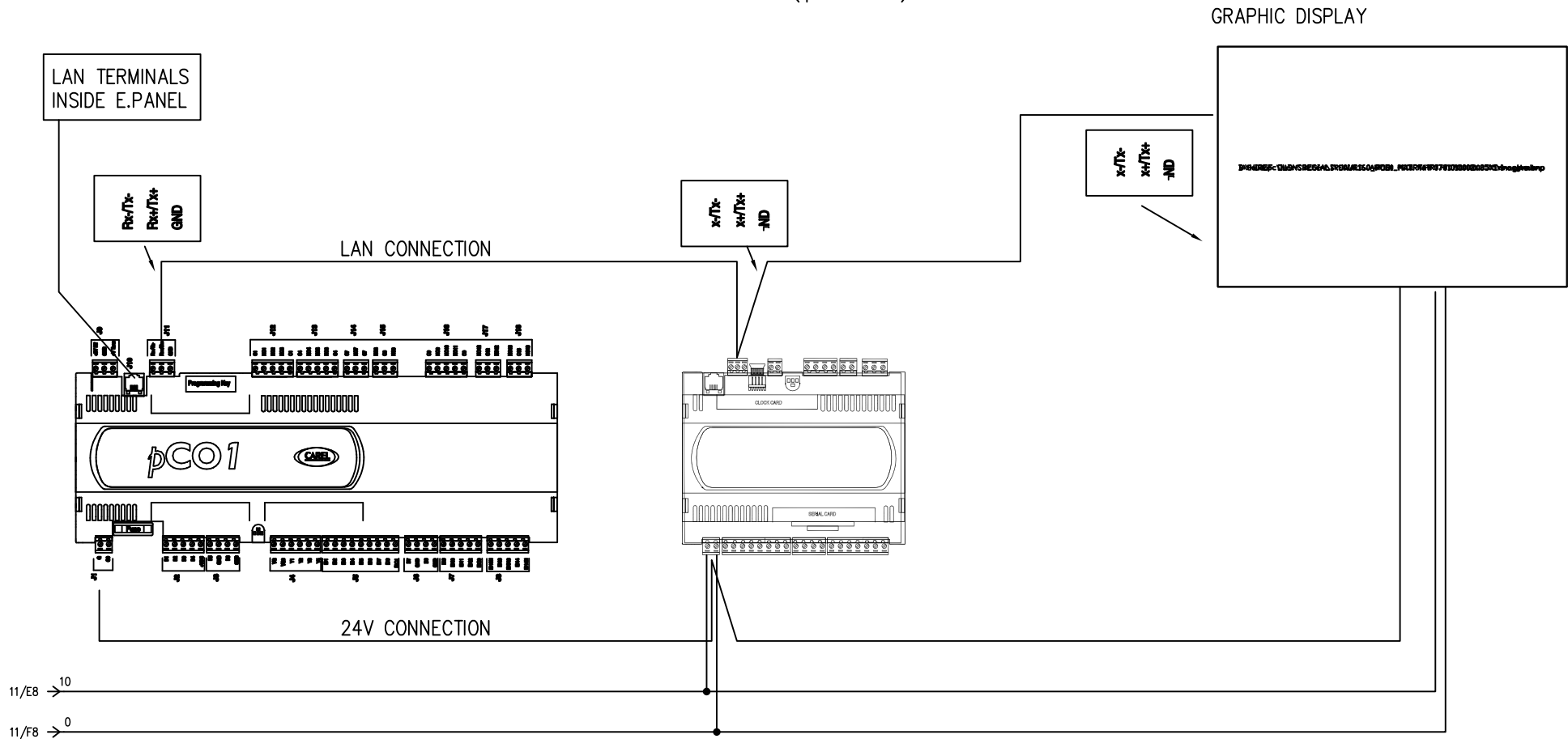

				DATE	14/07/2005	LENNOX			
				DRAW.	P.M.				
				CHECK	P.M.				
REV.	MODIFICATIONS	DATE	SIGN.	APPR.	M.M.	REPLACE	REPLACE	ORIGIN:	
1		2			3			4	5
									6
									7
									8
								HF620C0302	SHEET 13-1 OF CONTINUE

HUMID. CONNECTOR

C1
CONNETTORE FEMMINA 4 VIE AMP 1-480703-0

Pin	Filo	Posizione
1	49	5/C6
2	50	5/C6
3	51	5/C6
4	52	5/C6

C2
CONNETTORE FEMMINA 4 VIE AMP 1-480703-0

Pin	Filo	Posizione
1	94	7/D4
2	00	7/E4
3	93	7/D7
4	00	7/E7

C3
CONNETTORE FEMMINA 4 VIE AMP 1-480703-0

Pin	Filo	Posizione
1	42	4/E1
2	54	4/E2
3	26	4/E2
4		4/E2

LAYOUT SCHEDA
ELECTRONIC BOARD LAYOUT

TYPE OF SERIAL CARD:
SERIAL CARD RS485
SERIAL CARD RS232
SERIAL CARD LONWORKS
SERIAL CARD pCOWEB

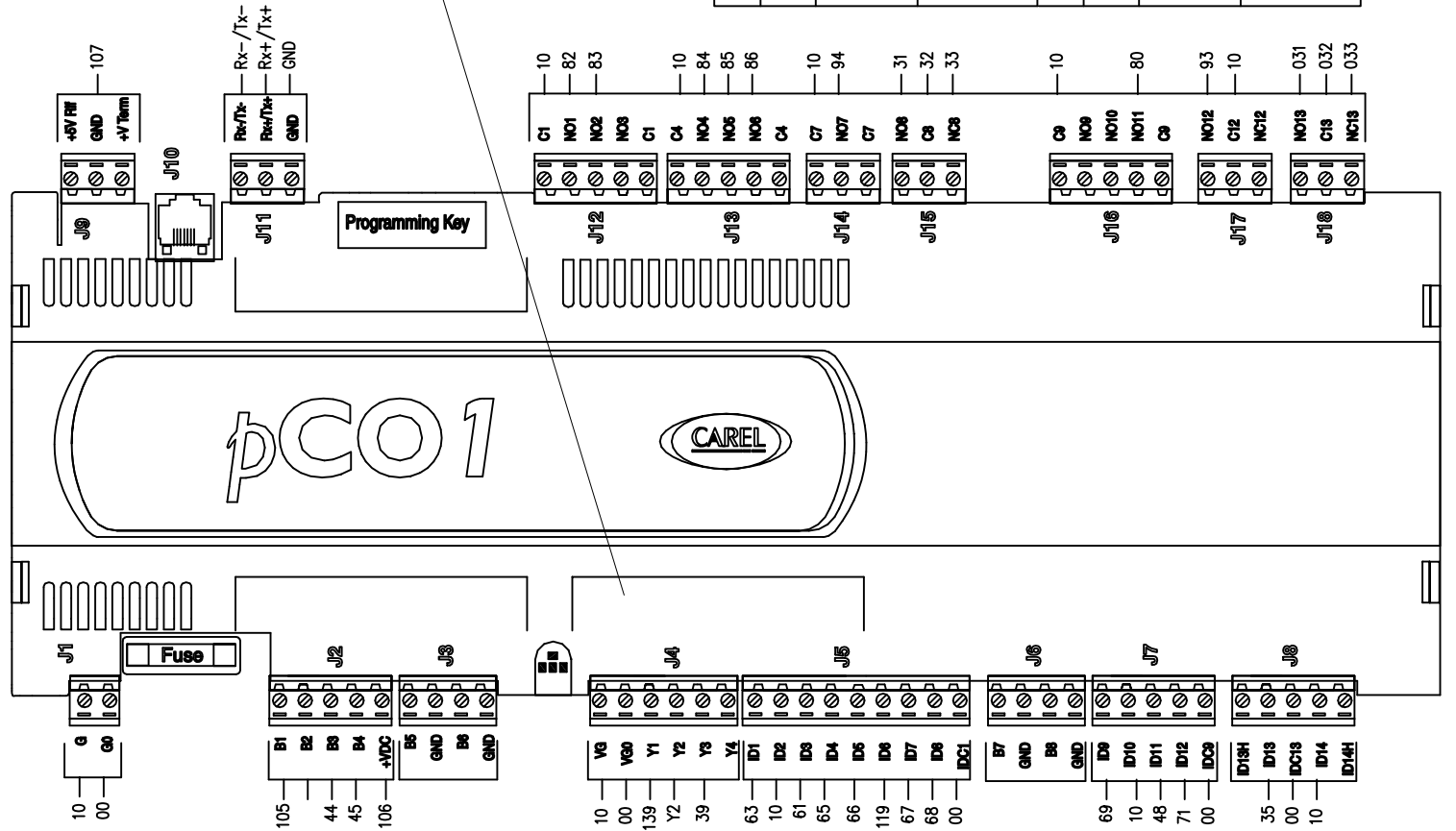

CONNETTORI PHOENIX A SPINA COMBICON CON PASSO 5.08 mm. COLORE VERDE TIPO MSTB 2,5 :

SIG.	POLI	TIPO	CODICE	SIG.	POLI	TIPO	CODICE
J1	2	2,5/2-ST	17 57 01 9	J11	3	2,5/3-ST	17 57 02 2
J2	5	2,5/5-ST	17 57 04 8	J12	5	2,5/5-ST	17 57 04 8
J3	4	2,5/4-ST	17 57 03 5	J13	5	2,5/5-ST	17 57 04*8
J4	6	2,5/6-ST	17 57 05 1	J14	3	2,5/3-ST	17 57 02 2
J5	9	2,5/9-ST	17 57 08 0	J15	3	2,5/3-ST	17 57 02 2
J6	4	2,5/4-ST	17 57 03 5	J16	5	2,5/5-ST	17 57 04 8
J7	5	2,5/5-ST	17 57 04 8	J17	3	2,5/3-ST	17 57 02 2
J8	5	2,5/5-ST	17 57 04 8	J18	3	2,5/3-ST	17 57 02 2
J9	3	2,5/3-ST	17 57 02 2				PCDUMD

DATE 14/07/2005
DRAW. P.M.
CHECK P.M.



LAYOUT 300...380

F2=USARE MORSETTI PORTAFUBILI PHOENIX UK5-HESI INTERBLOCATI

CAVO NPI 4X2,5mmq L=1000mm M1
 CAVO NPI 2X1mmq L=1000mm TP3
 CAVO NPI 2X1mmq L=1000mm TP4

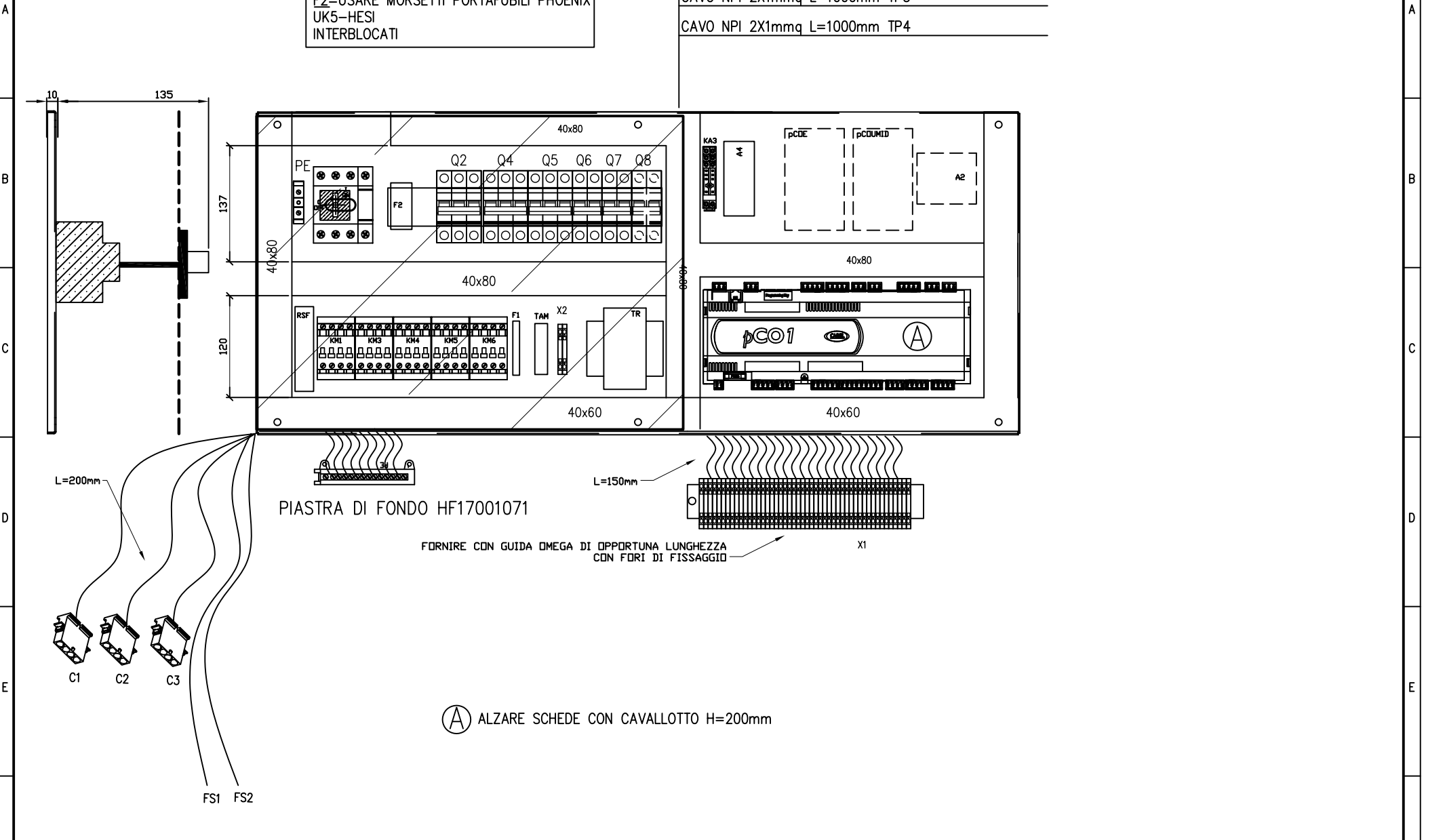

(A) ALZARE SCHEDE CON CAVALLOTTO H=200mm

DATE 14/07/2005		DRAW. P.M.		CHECK P.M.		ORIGIN:		HF620C0302		SHEET 16 OF 21	
REV.	MODIFICATIONS	DATE	SIGN.	APPR. M.M.	REPLACE	REPLACE	ORIGIN:			CONTINUE 17	
1		2		3		4		5	6	7	8



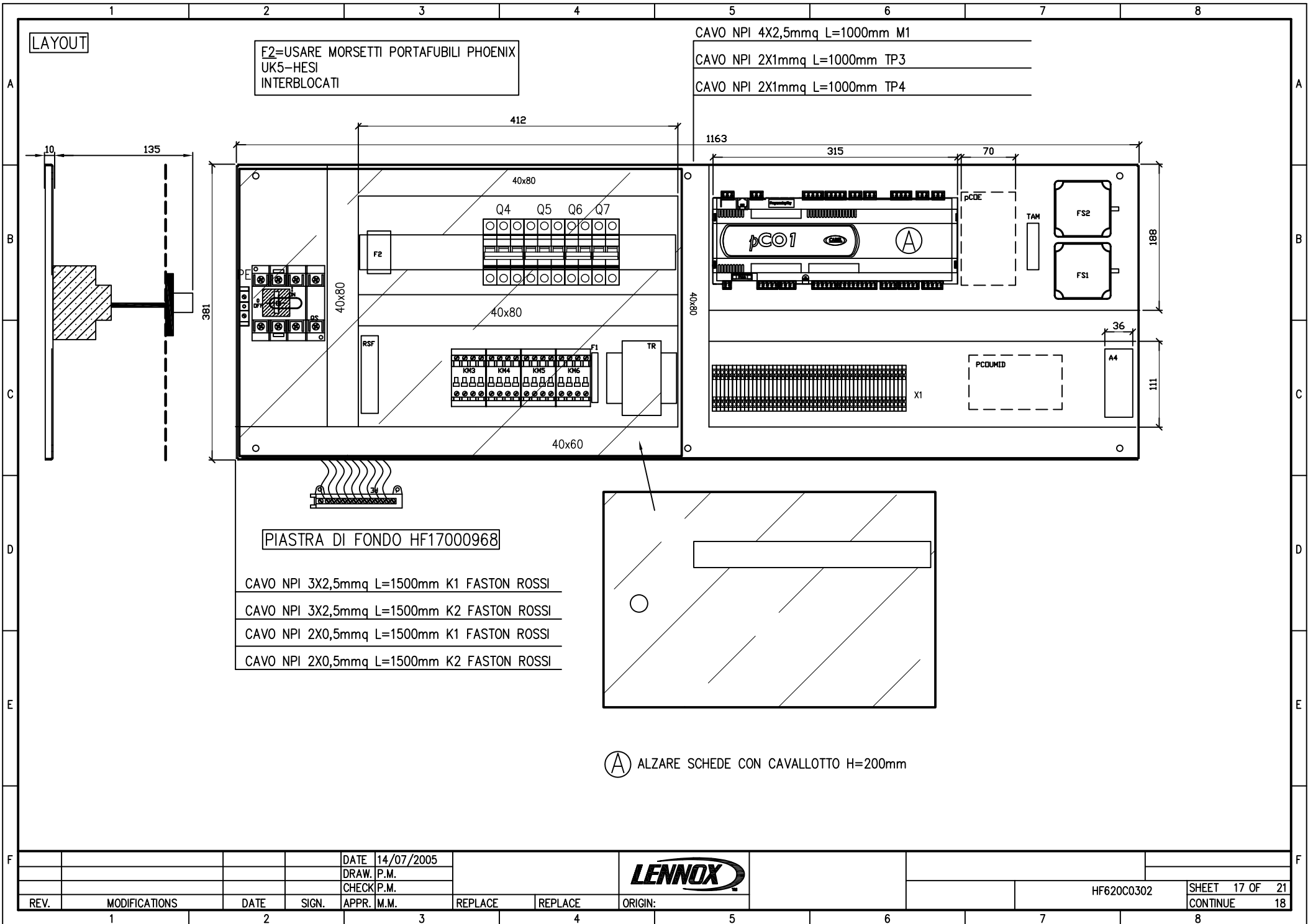

1		2		3		4		5		6		7		8	
300...1000	Ref-mark	Function		Technical data		Item code		Description		Amount	M.U.	Position			
	FU1			4AF				FUSIBILE 5X20		1	PCE	3/D08			
	KM3	HUMIDIFIER		SIEMENS		3RT1016-1AB01		TELER. 4KW 400V 3P BOB. 24V AC		1	PCE	4/E07			
	KM4	EVAP. FANS		SIEMENS		3RT1025-1AB00 3RH1921-1DA11		TELER. 7,5KW 400V 3P BOB. 24V AC CONTATTO AUSILIARIO 1NA+1NC		1	PCE	4/E07			
	KM5	E.H. 1 STEP		SIEMENS		3RT1016-1AB01		TELER. 4KW 400V 3P BOB. 24V AC		1	PCE	6/B03			
	KM6	E.H. 2 STEP		SIEMENS		3RT1016-1AB01		TELER. 4KW 400V 3P BOB. 24V AC		1	PCE	6/B03			
	M1/M2/M3	EVAP. FANS								1		3/E05			
	Q4	HUMIDIFIER		SIEMENS		5SY6 316-7		INT. AUT. 3P C16A 6KA		1	PCE	3/B07			
	Q5	FANS		SIEMENS		5SY6 320-8		INT. AUT. 3P D20A 6KA		1	PCE	3/B07			
	Q6	E. HEATING		SIEMENS		5SY6 332-7		INT. AUT. 3P C32A 6KA		1	PCE	3/B07			
	Q7	AUX		SIEMENS		5SY6 204-7		INT. AUT. 2P C 4A 6KA		1	PCE	3/B07			
	QS			ABB		OT32E4+OHY2AJ+OXS5X85		SEZ. 4P In= 32A+MANIGLIA+ALBERO (TAGLIATO A 75mm)		1		3/A01			
	R1	E. HEATING								1		3/E04			
	RSF	RELE' SEQUENZA FASI								1		3/C02			
	SA	ROOM PROBE								1		6/B05			
	TR			150VA				CON FUS. A BORDO		1		3/C07			
				DATE 14/07/2005											
				DRAW. P.M.											
				CHECK P.M.											
REV.	MODIFICATIONS	DATE	SIGN.	APPR.	M.M.	REPLACE	REPLACE	ORIGIN:			HF620C0302		SHEET 18 OF 19		
1		2		3		4		5	6	7	8	CONTINUE			



