

Section A-A

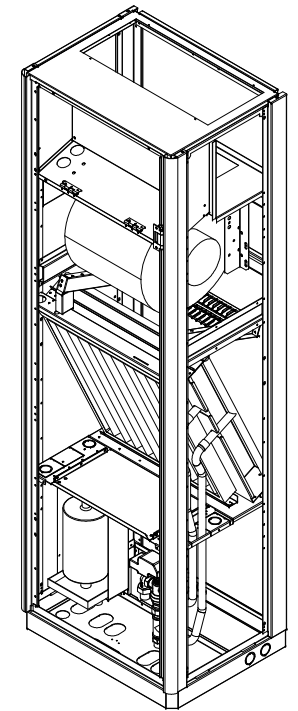
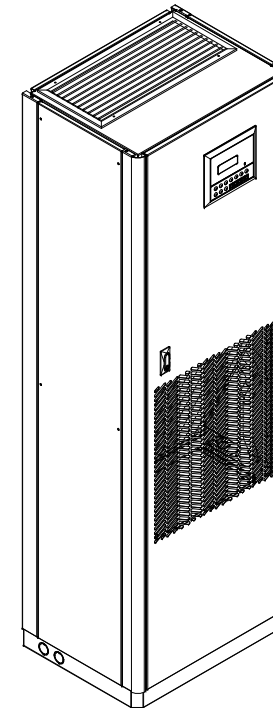
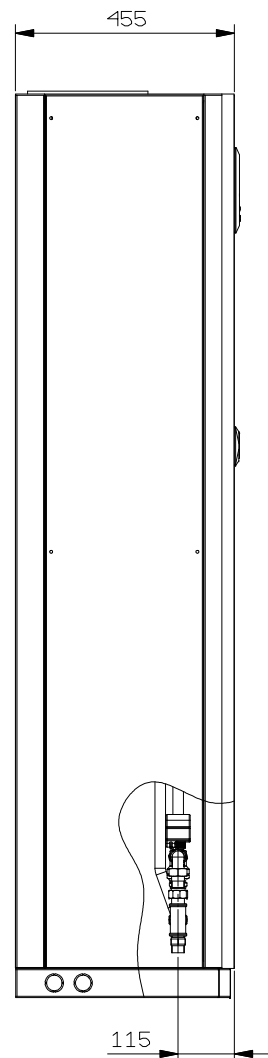
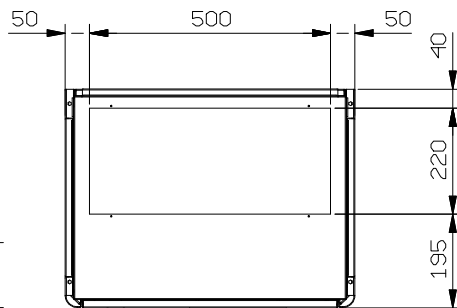
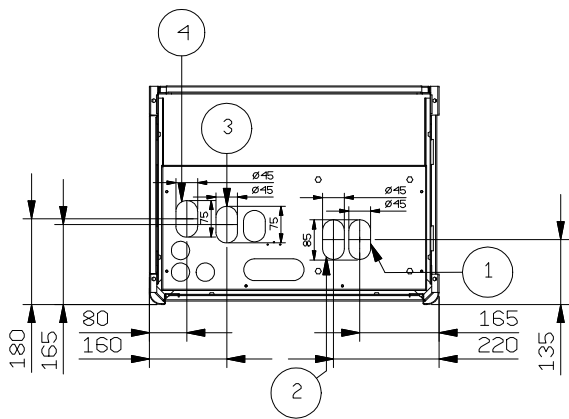

(1)	COOLING WATER INLET 3/4" GAS MALE
(2)	COOLING WATER OUTLET 3/4" GAS MALE
(3)	HUMIDIFIER WATER SUPPLY
(4)	HUMIDIFIER WATER DRAIN

LENNOX	Rev.	Modifica - Description	Date/e-Viso/Ckd
	Rev.	Modifica - Description	Date/e-Viso/Ckd
Descrizione - Description DIMENSIONI INGOMBRO OVERALL DIMENSIONS	Draftsman Strazzacappa	Date - Date 04/02/05	Scale - Scale 1:8
	Serie - Series DHCC	Modello - Model 0080-0110	Materiale - Material Trattamento - Treatment
Codice/Disegno - Code/Drawing HF640C0167	Peso - Weight (kg)	Rev.	Viso - Checkd