

SEZ. A - A

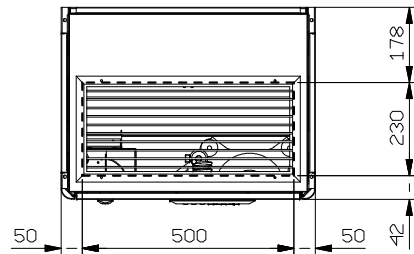
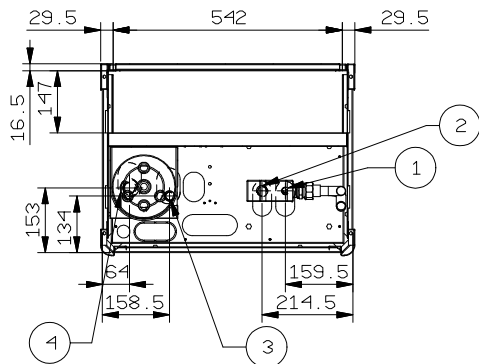
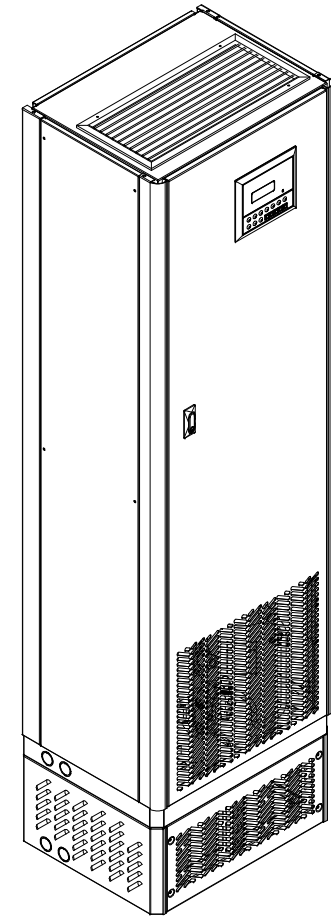
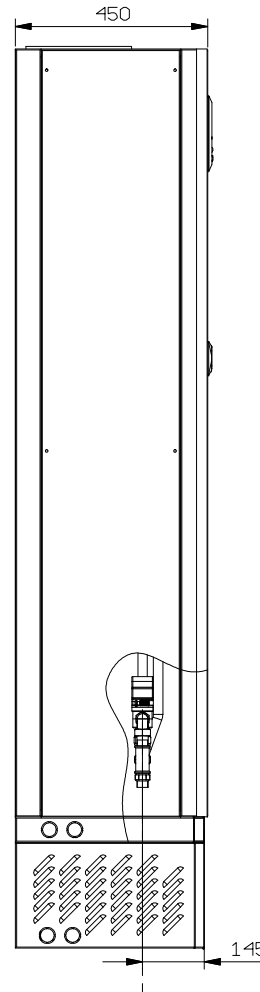
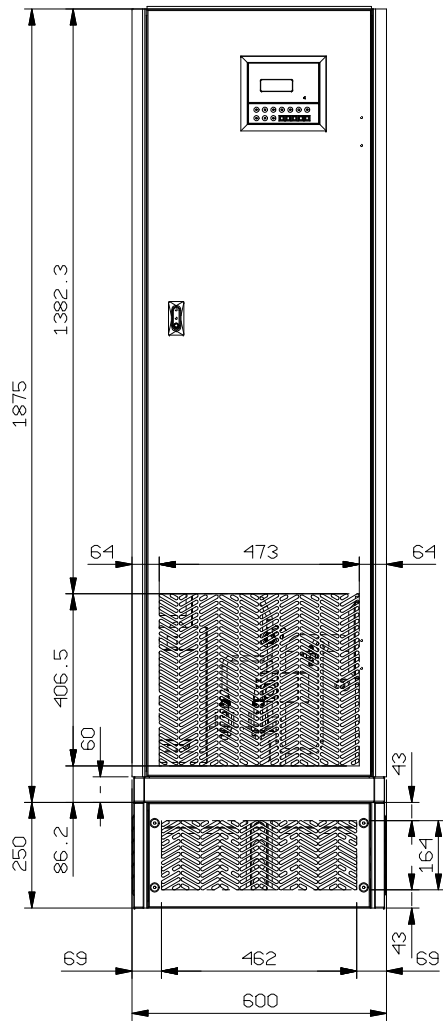

(1)	COOLING WATER INLET 3/4" GAS MALE
(2)	COOLING WATER OUTLET 3/4" GAS MALE
(3)	HUMIDIFIER WATER SUPPLY - 3/4" GAS MALE
(4)	HUMIDIFIER WATER DRAIN - Ø32mm

LENNOX	Rev. B	Modifica - Description Aggiornate connessioni umidificatore	Date/Rev-Viso/Okd 30/05/08 NP
	Rev. A	Modifica - Description Sostituzione valvola CW e umidificatore	Date/Rev-Viso/Okd 06/03/08 NP
Drafter/Man Pedrotta	Date - Date 09/01/06	Scale - Scale 1:9	◀ ⊕
Descrizione - Description DIMENSIONI INGOMBRO OVERALL DIMENSIONS		Serie - Series DHCXC	Materiale - Material /
Codice/Disegno - Code/Drawing HF64000197		Modello - Model 0080_0110 F1	Treatment - Treatment /
Peso - Weight (kg) /		Rev. B	Viso - Checked